

I

(Acts whose publication is obligatory)

**REGULATION (EC) No 2003/2003 OF THE EUROPEAN PARLIAMENT AND OF THE COUNCIL
of 13 October 2003
relating to fertilisers**

(Text with EEA relevance)

THE EUROPEAN PARLIAMENT AND THE COUNCIL OF THE EUROPEAN UNION,

Having regard to the Treaty establishing the European Community, and in particular Article 95 thereof,

Having regard to the proposal from the Commission ⁽¹⁾,

Having regard to the Opinion of the European Economic and Social Committee ⁽²⁾,

Acting in accordance with the procedure laid down in Article 251 of the Treaty ⁽³⁾,

Whereas:

(1) Council Directive 76/116/EEC of 18 December 1975 on the approximation of the laws of the Member States relating to fertilisers ⁽⁴⁾, Council Directive 80/876/EEC of 15 July 1980 on the approximation of the laws of the Member States relating to straight ammonium nitrate fertilisers of high nitrogen content ⁽⁵⁾, Commission Directive 87/94/EEC of 8 December 1986 on the approximation of the laws of the Member States relating to procedures for the control of characteristics of, limits for and resistance to detonation of straight ammonium nitrate fertilisers of high nitrogen content ⁽⁶⁾, and Commission Directive 77/535/EEC of 22 June 1977 on the approximation of the laws of the Member States relating to methods of sampling and analysis for fertilisers ⁽⁷⁾, have been substantially amended several times. In accordance with the communication from the Commission to the

European Parliament and the Council 'Simpler legislation for the internal market' (SLIM) and the Action Plan for the Single Market those Directives should be repealed and replaced by a single legal instrument, in the interests of clarity.

(2) The Community legislation on fertilisers is very technical in its content. A Regulation is therefore the most appropriate legal instrument, as it imposes directly on manufacturers precise requirements to be applied at the same time and in the same manner throughout the Community.

(3) In each Member State fertilisers must display certain technical characteristics laid down by mandatory provisions. These provisions, concerning more particularly the composition and definition types of fertilisers, the designations of these types, their identification and their packaging, differ from one Member State to another. By their disparity they hinder trade within the Community and should therefore be harmonised.

(4) Since the objective of the proposed action, namely to ensure the internal market in fertilisers, cannot be sufficiently achieved by the Member States if there are no common technical criteria and can therefore, by reason of the scale of the action, be better achieved at Community level, the Community may adopt measures in accordance with the principle of subsidiarity as set out in Article 5 of the Treaty. In accordance with the principle of proportionality, as set out in that Article, this Regulation does not go beyond what is necessary in order to achieve this objective.

(5) It is necessary to determine at Community level the designation, definition and composition of certain fertilisers (EC fertilisers).

(6) Community rules on the identification, traceability and labelling of EC fertilisers and on the closure of the packages should also be laid down.

(7) A procedure should be established at Community level to be followed in cases where a Member State deems it necessary to restrict the placing on the market of EC fertilisers.

⁽¹⁾ OJ C 51 E, 26.2.2002, p. 1 and OJ C 227 E, 24.9.2002, p. 503.

⁽²⁾ OJ C 80, 3.4.2002, p. 6.

⁽³⁾ Opinion of the European Parliament of 10 April 2002 (OJ C 127 E, 29.5.2002, p. 160), Council Common Position of 14 April 2003 (OJ C 153 E, 1.7.2003, p. 56) and Decision of the European Parliament of 2 September 2003 (not yet published in the Official Journal).

⁽⁴⁾ OJ L 24, 30.1.1976, p. 21. Directive as last amended by Directive 98/97/EC of the European Parliament and the Council (OJ L 18, 23.1.1999, p. 60).

⁽⁵⁾ OJ L 250, 23.9.1980, p. 7. Directive as amended by Directive 97/63/EC of the European Parliament and the Council (OJ L 335, 6.12.1997, p. 15).

⁽⁶⁾ OJ L 38, 7.2.1987, p. 1. Directive as amended by Directive 88/126/EEC (OJ L 63, 9.3.1988, p. 12).

⁽⁷⁾ OJ L 213, 22.8.1977, p. 1. Directive as last amended by Directive 95/8/EC (OJ L 86, 20.4.1995, p. 41).

- (8) The production of fertilisers is subject to varying degrees of fluctuation due to manufacturing techniques or basic materials. Sampling and analytical procedures may also contain variations. It is therefore necessary to authorise tolerances on the declared nutrient contents. In the interest of the agricultural user, it is advisable to keep these tolerances within narrow limits.
- (9) Official controls on the compliance of EC fertilisers with requirements of this Regulation concerning quality and composition should be carried out by laboratories that are approved by the Member States and notified to the Commission.
- (10) Ammonium nitrate is the essential ingredient of a variety of products, some of which are intended for use as fertilisers and others as explosives. It is necessary, having regard to the particular nature of ammonium nitrate fertilisers of high nitrogen content and to the consequent requirements regarding public safety, health and protection of workers, to lay down additional Community rules for EC fertilisers of this type.
- (11) Certain of those products could be hazardous and could in certain instances be used for purposes other than those for which they were intended. This could well endanger the security of persons and property. Manufacturers should therefore be obliged to take appropriate steps to avoid such use, and in particular to ensure the traceability of such fertilisers.
- (12) In the interest of public safety, it is particularly important to determine at Community level the characteristics and properties distinguishing ammonium nitrate EC fertilisers of high nitrogen content from varieties of ammonium nitrate used in the manufacture of products used as explosives.
- (13) Ammonium nitrate EC fertilisers of high nitrogen content should conform to certain characteristics to ensure that they are harmless. Manufacturers should ensure that all high nitrogen content ammonium nitrate fertilisers have passed a test of resistance to detonation before those fertilisers are placed on the market.
- (14) It is necessary to establish rules on the methods of the closed thermal cycles even if these methods may not necessarily simulate all conditions arising during transport and storage.
- (15) Fertilisers can be contaminated by substances that can potentially pose a risk to human and animal health and the environment. Further to the opinion of the Scientific Committee on Toxicity, Ecotoxicity and the Environment (SCTEE), the Commission intends to address the issue of unintentional cadmium content in mineral fertilisers and will, where appropriate, draw up a proposal for a Regulation, which it intends to present to the European Parliament and the Council. Where appropriate, a similar review will be undertaken for other contaminants.
- (16) It is appropriate to establish a procedure, to be observed by any manufacturer or its representative that wishes to include a new type of fertiliser in Annex I in order to use the marking 'EC fertiliser'.
- (17) The measures necessary for the implementation of this Regulation should be adopted in accordance with Council Decision 1999/468/EC of 28 June 1999 laying down the procedures for the exercise of implementing powers conferred on the Commission ⁽¹⁾.
- (18) Member States should lay down penalties in respect of infringements of the provisions of this Regulation. They may provide that a manufacturer which infringes Article 27 can be fined an amount equivalent to ten times the market value of the shipment that fails to comply.
- (19) Directives 76/116/EEC, 77/535/EEC, 80/876/EEC and 87/94/EEC should be repealed.

HAVE ADOPTED THIS REGULATION:

TITLE I

GENERAL PROVISIONS

CHAPTER I

Scope and definitions

Article 1

Scope

This Regulation shall apply to products which are placed on the market as fertilisers designated 'EC fertiliser'.

Article 2

Definitions

For the purposes of this Regulation the following definitions shall apply:

- (a) 'Fertiliser' means material, the main function of which is to provide nutrients for plants.
- (b) 'Primary nutrient' means the elements nitrogen, phosphorus and potassium only.
- (c) 'Secondary nutrient' means the elements calcium, magnesium, sodium and sulphur.
- (d) 'Micro-nutrients' means the elements boron, cobalt, copper, iron, manganese, molybdenum and zinc, essential for plant growth in quantities that are small compared with those of primary and secondary nutrients.

⁽¹⁾ OJ L 184, 17.7.1999, p. 23.

- (e) 'Inorganic fertiliser' means a fertiliser in which the declared nutrients are in the form of minerals obtained by extraction or by physical and/or chemical industrial processes. Calcium cyanamide, urea and its condensation and association products, and fertilisers containing chelated or complexed micro-nutrients may, by convention, be classed as inorganic fertilisers.
- (f) 'Chelated micro-nutrient' means a micro-nutrient that is held by one of the organic molecules listed in section E.3.1 of Annex I.
- (g) 'Complexed micro-nutrient' means a micro-nutrient that is held by one of the molecules listed in section E.3.2 of Annex I.
- (h) 'Type of fertilisers' means fertilisers with a common type designation as indicated in Annex I.
- (i) 'Straight fertiliser' means a nitrogenous, phosphatic or potassic fertiliser having a declarable content of only one of the primary nutrients.
- (j) 'Compound fertiliser' means a fertiliser having a declarable content of at least two of the primary nutrients and obtained chemically or by blending or by a combination of both.
- (k) 'Complex fertiliser' means a compound fertiliser, obtained by chemical reaction, by solution, or in its solid state by granulation, having a declarable content of at least two of the primary nutrients. In its solid state each granule contains all the nutrients in their declared composition.
- (l) 'Blended fertiliser' means a fertiliser obtained by dry mixing of several fertilisers, with no chemical reaction.
- (m) 'Foliar fertiliser' means a fertiliser suitable for application to and nutrient uptake by the foliage of a crop.
- (n) 'Fluid fertiliser' means a fertiliser in suspension or solution.
- (o) 'Solution fertiliser' means a fluid fertiliser that is free of solid particles.
- (p) 'Suspension fertiliser' means a two-phase fertiliser in which solid particles are maintained in suspension in the liquid phase.
- (q) 'Declaration' means a statement of the amount of nutrients, including their forms and solubility, guaranteed within specified tolerances.
- (r) 'Declared content' means the content of an element, or its oxide, which, in accordance with Community legislation, is given on a label of an EC fertiliser or on the relevant accompanying document.
- (s) 'Tolerance' means the permitted deviation of the measured value of a nutrient content from its declared value.
- (t) 'European Standard' means CEN (European Committee for Standardisation) standards, which have been officially recognised by the Community and whose reference has been published in the *Official Journal of the European Communities*.
- (u) 'Package' means a sealable receptacle used to hold, protect, handle, and distribute fertilisers and holding not more than 1 000 kg.
- (v) 'Bulk' means a fertiliser not packaged as prescribed by this Regulation.
- (w) 'Placing on the market' means the supply of fertiliser, whether in return for payment or free of charge, or storage for the purpose of supply. Importation of a fertiliser into the customs territory of the European Community shall be deemed to constitute placing on the market.
- (x) 'Manufacturer' means the natural or legal person responsible for placing a fertiliser on the market; in particular a producer, an importer, a packager working for its own account, or any person changing the characteristics of a fertiliser, shall be deemed to be a manufacturer. However, a distributor who does not change the characteristics of the fertiliser shall not be deemed to be a manufacturer.

CHAPTER II

Placing on the market

Article 3

EC Fertiliser

A fertiliser belonging to a type of fertilisers listed in Annex I and complying with the conditions laid down in this Regulation, may be designated 'EC fertiliser'.

The designation 'EC fertiliser' shall not be used for a fertiliser which does not comply with this Regulation.

Article 4

Establishment within the Community

The manufacturer shall be established within the Community and shall be responsible for the conformity of the 'EC fertiliser' with the provisions of this Regulation.

Article 5

Free circulation

1. Without prejudice to Article 15 and other Community legislation, Member States shall not, on grounds of composition, identification, labelling or packaging, and other provisions contained in this Regulation, prohibit, restrict or hinder the placing on the market of fertilisers marked 'EC fertiliser' which comply with the provisions of this Regulation.

2. Fertilisers that are marked 'EC fertiliser' in accordance with this Regulation shall circulate freely within the Community.

Article 6

Compulsory statements

1. In order to satisfy the requirements of Article 9, Member States may prescribe that the indication of the nitrogen, phosphorus and potassium contents of fertilisers placed on their market is to be expressed in the following way:

- (a) nitrogen solely in the elemental form (N); and either
- (b) phosphorus and potassium solely in the elemental form (P, K); or
- (c) phosphorus and potassium solely in the oxide form (P_2O_5 , K_2O); or
- (d) phosphorus and potassium in both elemental and oxide forms simultaneously.

Where the option is chosen to prescribe that the phosphorus and potassium contents be expressed in the form of elements, all references in the Annexes to the oxide form shall be read as being in elemental form and the numerical values shall be converted using the following factors:

- (a) phosphorus (P) = phosphorus pentoxide (P_2O_5) \times 0,436;
- (b) potassium (K) = potassium oxide (K_2O) \times 0,830.

2. Member States may prescribe that the calcium, magnesium, sodium and sulphur contents of secondary nutrient fertilisers and, where the conditions of Article 17 are fulfilled, of primary nutrient fertilisers placed on their markets are to be expressed:

- (a) in the oxide form (CaO, MgO, Na_2O , SO_3); or
- (b) in the elemental form (Ca, Mg, Na, S); or
- (c) in both of these forms.

To convert the calcium oxide, magnesium oxide, sodium oxide and sulphur trioxide contents into calcium, magnesium, sodium and sulphur contents, the following factors shall be used:

- (a) calcium (Ca) = calcium oxide (CaO) \times 0,715;
- (b) magnesium (Mg) = magnesium oxide (MgO) \times 0,603;
- (c) sodium (Na) = sodium oxide (Na_2O) \times 0,742;
- (d) sulphur (S) = sulphur trioxide (SO_3) \times 0,400.

For the calculated oxide or elemental content, the figure declared shall be rounded to the nearest decimal place.

3. Member States shall not prevent the placing on the market of an 'EC fertiliser' labelled in both of the forms mentioned in paragraphs 1 and 2.

4. The content of one or more of the micro-nutrients boron, cobalt, copper, iron, manganese, molybdenum, or zinc in the EC fertilisers belonging to the types of fertilisers listed in sections A, B, C and D of Annex I shall be declared where the following conditions are fulfilled:

- (a) the micro-nutrients are added at least in the minimum quantities specified in section E.2.2 and E.2.3 of Annex I;
- (b) the EC fertiliser continues to satisfy the requirements of sections A, B, C and D of Annex I.

5. Where the micro-nutrients are the normal ingredients of the raw materials intended to supply primary (N, P, K) and secondary (Ca, Mg, Na, S) nutrients, they may be declared, provided that these micro-nutrients are present at least in the minimum quantities specified in sections E.2.2 and E.2.3 of Annex I.

6. The micro-nutrient content shall be declared in the following manner:

- (a) for fertilisers belonging to the types of fertilisers listed in section E.1 of Annex I, in accordance with the requirements set out in column 6 of that section;
- (b) for mixtures of fertilisers referred to in (a) containing at least two different micro-nutrients and meeting the requirements of section E.2.1 of Annex I and for fertilisers belonging to the types of fertilisers listed in sections A, B, C and D of Annex I, by indicating:
 - (i) the total content, expressed as a percentage of the fertiliser by mass,
 - (ii) the water-soluble content, expressed as a percentage of the fertiliser by mass, where the soluble content is at least half of the total content.

Where a micro-nutrient is totally water-soluble, only the water-soluble content shall be declared.

Where a micro-nutrient is chemically linked with an organic molecule, the content of the micro-nutrient present in the fertiliser shall be declared immediately following the water-soluble content as a percentage by mass of the product, followed by one of the terms 'chelated by', or 'complexed by', with the name of the organic molecule as set out in section E.3 of Annex I. The name of the organic molecule may be replaced by its initials.

Article 7

Identification

1. The manufacturer shall provide EC fertilisers with the identification markings listed in Article 9.

2. If the fertilisers are packed, these identification markings shall appear on the packages or labels attached. If the fertilisers are in bulk, these markings shall appear on the accompanying documents.

*Article 8***Traceability**

Without prejudice to Article 26(3), the manufacturer shall, to ensure traceability of EC fertilisers, maintain records of the origin of the fertilisers. These records shall be available for inspection by Member States for as long as the fertiliser is being supplied to the market, and for a further period of 2 years after the manufacturer stopped supplying it.

*Article 9***Markings**

1. Without prejudice to other Community rules, the packages, labels and accompanying documents, referred to in Article 7 shall bear the following markings:

(a) Compulsory identification

- The words 'EC FERTILISER' in capital letters;
- Where it exists, the designation of the type of fertiliser as set out in Annex I;
- For blended fertilisers, the marking 'blend' after the designation of the type;
- The additional markings specified in Article 19, 21 or 23;
- Nutrients shall be indicated both in words and by the appropriate chemical symbols, e.g. nitrogen (N), phosphorus (P), phosphorus pentoxide (P_2O_5), potassium (K), potassium oxide (K_2O), calcium (Ca), calcium oxide (CaO), magnesium (Mg), magnesium oxide (MgO), sodium (Na), sodium oxide (Na_2O), sulphur (S), sulphur trioxide (SO_3), boron (B), copper (Cu), cobalt (Co), iron (Fe), manganese (Mn), molybdenum (Mo), zinc (Zn);
- If the fertiliser contains micro-nutrients of which all or part are chemically linked with an organic molecule, the name of the micro-nutrient shall be followed by one of the following qualifiers:
 - (i) 'chelated by ...' (name of chelating agent or its abbreviation as set out in section E.3.1 of Annex I);
 - (ii) 'complexed by ...' (name of complexing agent as set out in section E.3.2 of Annex I);
- Micro-nutrients contained in the fertiliser, listed in the alphabetical order of their chemical symbols: B, Co, Cu, Fe, Mn, Mo, Zn;
- For products listed in sections E.1 and E.2 of Annex I, the specific directions for use;

- Quantities of fluid fertilisers, expressed by mass. The expression of quantities of fluid fertilisers by volume or in terms of mass versus volume (kilograms per hectolitre or grams per litre) shall be optional;
- Net or gross mass and, optionally, volume for fluid fertilisers. If the gross mass is given, the tare mass must be indicated beside it;
- The name or trade name and the address of the manufacturer.

(b) Optional identification

- As listed in Annex I;
- The directions for the storage and handling, and for fertilisers not listed in Annex I, sections E.1 and E.2, the specific directions for the use of the fertiliser;
- Indications of the dose rates and conditions of use suitable for the soil and crop conditions under which the fertiliser is used;
- The mark of the manufacturer and the trade description of the product.

The indications referred to in (b) must not conflict with those referred to in (a) and must be clearly separated from them.

2. All the markings referred to in paragraph 1 must be clearly separated from any other information on the packages, labels and accompanying documents.

3. Fluid fertilisers may be placed on the market only if the manufacturer provides suitable additional instructions covering, in particular, storage temperature and prevention of accidents during storage.

4. Detailed rules for the application of this Article shall be adopted under the procedure referred to in Article 32(2).

*Article 10***Labelling**

1. The labels or markings printed on the package and giving the particulars mentioned under Article 9 must be placed in a conspicuous position. Labels must be attached to the package or to whatever system is used for closing it. If this system consists of a seal, that seal must bear the name or mark of the packager.

2. The markings referred to in paragraph 1 must be and must remain indelible and clearly legible.

3. In the cases of fertilisers in bulk referred to in the second sentence of Article 7(2) a copy of the documents containing the identification markings must accompany the goods and be accessible for inspection purposes.

*Article 11***Languages**

The label, the markings on the package and the accompanying documents must appear in at least the national language or languages of the Member State in which the EC fertiliser is marketed.

*Article 12***Packaging**

In the case of packaged EC fertilisers, the package must be closed in such a way or by such a device that, when it is opened, the fastening, fastening seal or the package itself is irreparably damaged. Valve sacks may be used.

*Article 13***Tolerances**

1. The nutrient content of EC fertilisers shall comply with the tolerances established in Annex II, which are intended to allow for deviations in manufacture, sampling and analysis.
2. The manufacturer shall not take systematic advantage of the tolerances given in Annex II.
3. No tolerances are allowed in respect of the minimum and maximum contents specified in Annex I.

*Article 14***Fertiliser requirements**

A type of fertiliser may only be included in Annex I if:

- (a) it provides nutrients in an effective manner;
- (b) relevant sampling, analysis, and if required, test methods are being provided.
- (c) under normal conditions of use it does not adversely affect human, animal, or plant health, or the environment.

*Article 15***Safeguard clause**

1. Where a Member State has justifiable grounds for believing that a specific EC fertiliser, although satisfying the requirements of this Regulation, constitutes a risk to safety or health of humans, animals or plants or a risk to the environment, it may temporarily prohibit the placing on the

market of that fertiliser in its territory or make it subject to special conditions. It shall immediately inform the other Member States and the Commission thereof, giving the reasons for its decision.

2. The Commission shall adopt a decision on the matter within 90 days from the receipt of the information in accordance with the procedure referred to in Article 32(2).

3. The provisions of this Regulation shall not preclude the taking of measures by the Commission or by a Member State which are justified on grounds of public security to prohibit, restrict or hinder the placing on the market of EC fertilisers.

TITLE II

PROVISIONS FOR SPECIFIC TYPES OF FERTILISERS

CHAPTER I

Inorganic primary nutrient fertilisers*Article 16***Scope**

This chapter shall apply to inorganic primary nutrient fertilisers, solid or fluid, straight or compound, including those containing secondary nutrients and/or micro-nutrients, with the minimum nutrient content established in sections A, B, C, E.2.2 or E.2.3 of Annex I.

*Article 17***Declaration of secondary nutrients in primary nutrient fertilisers**

Calcium, magnesium, sodium and sulphur content may be declared as secondary nutrient content of EC fertilisers belonging to the types of fertiliser listed in sections A, B and C of Annex I, provided that these elements are present in at least the following minimum quantities:

- (a) 2 % calcium oxide (CaO), i.e. 1,4 % Ca;
- (b) 2 % of magnesium oxide (MgO), i.e. 1,2 % Mg;
- (c) 3 % of sodium oxide (Na₂O), i.e. 2,2 % Na;
- (d) 5 % of sulphur trioxide (SO₃), i.e. 2 % S.

In such a case, the additional marking specified in Article 19(2)(ii) shall be added to the type designation.

Article 18

Calcium, magnesium, sodium and sulphur

1. The declaration of the magnesium, sodium and sulphur content of the fertilisers listed in sections A, B, and C of Annex I shall be expressed in one of the following ways:

- (a) the total content expressed as a percentage of the fertiliser by mass;
- (b) the total content and the content soluble in water, expressed as a percentage of the fertiliser by mass where the soluble content is at least a quarter of the total content;
- (c) where an element is totally soluble in water, only the content soluble in water shall be declared as a percentage of the mass.

2. Unless otherwise stated in Annex I, a declaration of the calcium content shall only be made if it is soluble in water and shall be expressed as a percentage of the fertiliser by mass.

Article 19

Identification

1. In addition to the compulsory identification markings referred to in Article 9(1)(a), the markings set out in paragraphs 2, 3, 4, 5 and 6 of this Article shall be stated.

2. The following shall be stated after the type designation of compound fertilisers:

- (i) The chemical symbols of the declared secondary nutrients, between brackets and after the symbols of the primary nutrients.
- (ii) Numbers indicating the primary nutrient content. The declared secondary nutrient content shall be indicated between brackets after the primary nutrient content.

3. The fertiliser type designation shall only be followed by figures indicating primary and secondary nutrient content.

4. Where micro-nutrients are declared, the words 'with micro-nutrients' or the word 'with' followed by the name or names and chemical symbols of the micro-nutrients present shall be given.

5. The declared content of primary nutrients and secondary nutrients shall be given as a percentage by mass, as whole numbers or, where necessary, where an appropriate method of analysis exists, to one decimal place.

In fertilisers containing more than one declared nutrient, the order shall be for primary nutrients: N, P₂O₅ and/or P, K₂O and/or K, and for secondary nutrients: CaO and/or Ca, MgO and/or Mg, Na₂O and/or Na, SO₃ and/or S.

The declared content of micro-nutrients shall give the name and symbol of each micro-nutrient, indicating the percentage by mass as specified in sections E.2.2 and E.2.3 of Annex I and according to solubility.

6. The forms and solubility of the nutrients shall also be expressed as a percentage by mass of fertiliser, except where Annex I explicitly provides that this content shall be otherwise expressed.

The number of decimal places shall be one, except for micro-nutrients where it shall be as specified in sections E.2.2 and E.2.3 of Annex I.

CHAPTER II

Inorganic secondary nutrient fertilisers

Article 20

Scope

This chapter shall apply to inorganic secondary nutrient fertilisers, solid or fluid, including those containing micro-nutrients, with the minimum nutrient content established in sections D, E.2.2, and E.2.3 of Annex I.

Article 21

Identification

1. In addition to the compulsory identification markings referred to in Article 9(1)(a), the markings set out in paragraphs 2, 3, 4 and 5 of this Article shall be stated.

2. Where micro-nutrients are declared, the words 'with micro-nutrients' or the word 'with', followed by the name or names and chemical symbols of the micro-nutrients present, shall be given.

3. The declared content of secondary nutrients shall be given as a percentage by mass, as whole numbers or, where necessary, where an appropriate method of analysis exists, to one decimal place.

Where more than one secondary nutrient is present, the order shall be:

CaO and/or Ca, MgO and/or Mg, Na₂O and/or Na, SO₃ and/or S.

The declared content of micro-nutrients shall give the name and symbol of each micro-nutrient, indicating the percentage by mass as specified in sections E.2.2 and E.2.3 of Annex I and according to solubility.

4. The forms and solubility of the nutrients shall also be expressed as a percentage by mass of fertiliser, except where Annex I explicitly provides that this content shall be otherwise expressed.

The number of decimal places shall be one, except for micro-nutrients where it shall be as specified in sections E.2.2 and E.2.3 of Annex I.

5. Unless otherwise stated in Annex I, a declaration of the calcium content shall only be made if it is soluble in water and shall be expressed as a percentage of the fertiliser by mass.

CHAPTER III

Inorganic micro-nutrient fertilisers

Article 22

Scope

This chapter shall apply to inorganic micro-nutrient fertilisers, solid or fluid, with the minimum nutrient content established in sections E.1 and E.2.1 of Annex I.

Article 23

Identification

1. In addition to the compulsory identification markings referred to in Article 9(1)(a) the markings set out in paragraphs 2, 3, 4 and 5 of this Article shall be stated.

2. Where the fertiliser contains more than one micro-nutrient, the type designation 'mixture of micro-nutrients' followed by the names of the micro-nutrients present and their chemical symbols, shall be given.

3. For fertilisers containing only one micro-nutrient (section E.1 of Annex I), the declared micro-nutrient content shall be given as a percentage by mass, in whole numbers or, where necessary, to one decimal place.

4. The forms and solubility of micro-nutrients shall be expressed as a percentage by mass of fertiliser, except where Annex I explicitly provides that this content shall be otherwise expressed.

The number of decimal places for micro-nutrients shall be as specified in section E.2.1 of Annex I.

5. Below the compulsory or optional declarations the following shall be entered on the label and accompanying documents with regard to the products appearing in sections E.1 and E.2.1 of Annex I:

'To be used only where there is a recognised need. Do not exceed the appropriate dose rates.'

Article 24

Packaging

EC fertilisers covered by the provisions of this chapter shall be packaged.

CHAPTER IV

Ammonium nitrate fertilisers of high nitrogen content

Article 25

Scope

For the purpose of this chapter, ammonium nitrate fertilisers of high nitrogen content, straight or compound, are ammonium nitrate based products manufactured for use as fertilisers and containing more than 28 % by mass of nitrogen in relation to ammonium nitrate.

This type of fertiliser may contain inorganic or inert substances.

The substances used in the manufacturing of this type of fertiliser must not increase its sensitivity to heat or its tendency to detonate.

Article 26

Safety measures and controls

1. The manufacturer shall ensure that straight ammonium nitrate fertilisers of high nitrogen content comply with the provisions of section 1 of Annex III.

2. The checking, analysis and testing for official controls of straight ammonium nitrate fertilisers of high nitrogen content provided for by this chapter shall be carried out in accordance with the methods described in section 3 of Annex III.

3. To ensure the traceability of ammonium nitrate EC fertilisers of high nitrogen content placed on the market, the manufacturer shall maintain records of the names and addresses of the sites, and of the operators of the sites, at which the fertiliser and its principal components were produced. These records shall be available for inspection by Member States for as long as the fertiliser is being supplied to the market, and for a further period of 2 years after the manufacturer stopped supplying it.

Article 27

Test of resistance to detonation

Without prejudice to the measures referred to in Article 26, the manufacturer shall ensure that each type of EC high nitrogen content ammonium nitrate fertiliser placed on the market has passed the test of resistance to detonation described in sections 2, 3 (method 1, point 3) and 4 of Annex III of this Regulation. This test shall be carried out by one of the approved laboratories referred to in Article 30(1) or 33(1). Manufacturers shall submit the results of the test to the competent authority of the Member State concerned at least 5 days before placing the fertiliser on the market, or at least 5 days before the arrival of the fertiliser at the borders of the European Community in the case of imports. Thereafter, the manufacturer shall continue to guarantee that all supplies of the fertiliser placed on the market are capable of passing the abovementioned test.

*Article 28***Packaging**

Ammonium nitrate fertilisers of high nitrogen content shall be made available to the final user only in packaged form.

TITLE III

CONFORMITY ASSESSMENT OF FERTILISERS*Article 29***Control measures**

1. Member States may subject fertilisers marked 'EC fertiliser' to official control measures for the purpose of verifying that they comply with this Regulation.

Member States may charge fees not exceeding the cost of tests needed for such control measures, but this shall not oblige manufacturers to repeat tests or to pay for repeated tests where the first test was made by a laboratory which fulfilled the conditions of Article 30 and where the test showed compliance of the fertiliser in question.

2. Member States shall ensure that sampling and analysis for official controls of EC fertilisers belonging to types of fertilisers listed in Annex I are carried out in accordance with the methods described in Annex III and IV.

3. Compliance with this Regulation in respect of conformity to types of fertiliser and compliance with the declared nutrient content and/or the declared content expressed as forms and solubilities of such nutrients may be verified at official inspections only by means of sampling and analysis methods established in accordance with Annex III and IV and taking into account the tolerances specified in Annex II.

4. The adaptation and modernisation of measuring, sampling and analysis methods shall follow the procedure referred to in Article 32(2), and shall, wherever possible, use European Standards. The same procedure shall apply to the adoption of implementing rules needed to specify the control measures provided for in this Article and in Articles 8, 26 and 27 of this Regulation. Such rules shall in particular address the question of the frequency with which tests need to be repeated, as well as measures that are designed to ensure that the fertiliser put on the market is identical with the fertiliser tested.

*Article 30***Laboratories**

1. Member States shall notify to the Commission the list of those approved laboratories on their territories that are competent to provide the necessary services for checking compliance of EC fertilisers with the requirements of this Regu-

lation. Such laboratories must meet the standards mentioned in section B of Annex V. Such notification shall be made by 11 June 2004 and on the occasion of each subsequent modification.

2. The Commission shall publish the list of approved laboratories in the *Official Journal of the European Union*.

3. Where a Member State has justifiable grounds for believing that an approved laboratory does not meet the standards referred to in paragraph 1, it shall raise this matter in the committee referred to in Article 32. If the committee agrees that the laboratory does not meet the standards, the Commission shall remove the name from the list referred to in paragraph 2.

4. The Commission shall adopt a decision on the matter within 90 days from the receipt of the information in accordance with the procedure referred to in Article 32(2).

5. The Commission shall publish the amended list in the *Official Journal of the European Union*.

TITLE IV

FINAL PROVISIONS

CHAPTER I

Adaptation of the Annexes*Article 31***New EC fertilisers**

1. The inclusion of a new type of fertiliser in Annex I of this Regulation shall be adopted in accordance with the procedure referred to in Article 32(2).

2. A manufacturer or its representative which wishes to propose a new type of fertiliser for inclusion in Annex I and is required to compile a technical file for that purpose shall do so by taking into account the technical documents referred to in section A of Annex V.

3. Amendments required to adapt the Annexes to technical progress shall be adopted in accordance with the procedure referred to in Article 32(2).

*Article 32***Committee procedure**

1. The Commission shall be assisted by a committee.

2. Where reference is made to this paragraph, Articles 5 and 7 of Decision 1999/468/EC shall apply, having regard to the provisions of Article 8 thereof.

The period laid down in Article 5(6) of Decision 1999/468/EC shall be set at three months.

3. The committee shall adopt its rules of procedure.

CHAPTER II

Transitional provisions

Article 33

Competent laboratories

1. Without prejudice to the provisions of Article 30(1), Member States may for a transitional period until 11 December 2007 continue to apply their national provisions for authorising competent laboratories to provide the necessary services for checking compliance of EC fertilisers with the requirements of this Regulation.

2. Member States shall notify the list of these laboratories to the Commission, giving details of their authorisation scheme. Such notification shall be made by 11 June 2004 and on the occasion of each subsequent modification.

Article 34

Packaging and labelling

Notwithstanding Article 35(1), EC fertiliser markings, packagings, labels and accompanying documents provided for by earlier Directives may continue to be used until 11 June 2005.

CHAPTER III

Final provisions

Article 35

Repealed Directives

1. Directives 76/116/EEC, 77/535/EEC, 80/876/EEC and 87/94/EEC are hereby repealed.

2. References to the Directives repealed shall be construed as references to this Regulation. In particular, derogations from Article 7 of Directive 76/116/EEC that were granted by the Commission under Article 95(6) of the Treaty shall be construed as derogations from Article 5 of the present Regulation and shall continue to produce their effects notwithstanding the entry into force of this Regulation. Pending the adoption of penalties under Article 36, Member States may continue to apply penalties for infringements of national rules implementing the Directives mentioned in paragraph 1.

Article 36

Penalties

The Member States shall lay down the rules on penalties applicable to infringements of the provisions of this Regulation and shall take all measures necessary to ensure that they are implemented. The penalties provided for must be effective, proportionate and dissuasive.

Article 37

National provisions

The Member States shall notify the Commission by 11 June 2005 of any national provisions adopted pursuant to Articles 6(1), 6(2), 29(1) and 36 of this Regulation, and shall notify it without delay of any subsequent amendment affecting them.

Article 38

Entry into force

This Regulation shall enter into force on the twentieth day after its publication in the *Official Journal of the European Union* with the exception of Articles 8 and 26(3), which shall enter into force 11 June 2005.

This Regulation shall be binding in its entirety and directly applicable in all Member States.

Done at Luxembourg, 13 October 2003.

For the European Parliament

The President

P. COX

For the Council

The President

G. ALEMANN

TABLE OF CONTENTS

	<i>Page</i>
ANNEX I — List of types of EC fertilisers	15
A. Inorganic straight primary nutrient fertilisers	15
A.1. Nitrogenous fertilisers	15
A.2. Phosphatic fertilisers	19
A.3. Potassic fertilisers	22
B. Inorganic compound primary nutrient fertilisers	23
B.1. NPK fertilisers	23
B.2. NP fertilisers	27
B.3. NK fertilisers	30
B.4. PK fertilisers	32
C. Inorganic fluid fertilisers	34
C.1. Straight fluid fertilisers	34
C.2. Compound fluid fertilisers	36
D. Inorganic secondary nutrient fertilisers	42
E. Inorganic micro-nutrient fertilisers	43
E.1. Fertilisers containing only one micro-nutrient	43
E.1.1. Boron	43
E.1.2. Cobalt	44
E.1.3. Copper	45
E.1.4. Iron	46
E.1.5. Manganese	46
E.1.6. Molybdenum	47
E.1.7. Zinc	48
E.2. Minimum micro-nutrient content, percentage weight of fertiliser	49
E.3. List of authorised organic chelating and complexing agents for micro-nutrients	50
ANNEX II — Tolerances	51
1. Inorganic straight primary nutrient fertilisers — absolute value in percentage by mass expressed as N, P ₂ O ₅ , K ₂ O, MgO, CL	51
2. Inorganic compound primary nutrient fertilisers	52
3. Secondary nutrients in fertilisers	52
4. Micro-nutrients in fertilisers	52
ANNEX III — Technical provisions for Ammonium Nitrate Fertilisers of High Nitrogen Content	53
1. Characteristics of and limits for straight ammonium nitrate fertilisers of high nitrogen content	53

2. Description of the test of resistance to detonation concerning ammonium nitrate fertilisers of high nitrogen content	53
3. Methods of checking compliance with the limits specified in annexes III-1 and III-2	54
4. Determination of resistance to detonation	66
ANNEX IV — Methods of Sampling and Analysis	73
A. Method of sampling for the control of fertilisers	73
1. Purpose and scope	73
2. Sampling officers	73
3. Definitions	73
4. Apparatus	73
5. Quantitative requirements	74
6. Instructions for taking, preparing and Packaging the samples	75
7. Packaging of final samples	76
8. Sampling record	76
9. Destination of samples	76
B. Methods for the analysis of fertilisers	76
General observations	76
General provisions relating to method of analysing fertilisers	76
Method 1 — Preparation of the sample for analysis.....	76
Methods 2 — Nitrogen	78
Method 2.1 — Determination of ammoniacal nitrogen	78
Methods 2.2 — Determination of nitric and ammoniacal nitrogen	87
Method 2.2.1 — Determination of nitric and ammoniacal nitrogen according to Ulsch	87
Method 2.2.2 — Determination of nitric and ammoniacal nitrogen according to Arnd	88
Method 2.2.3 — Determination of nitric and ammoniacal nitrogen according to Devarda	90
Method 2.3 — Determination of total nitrogen	94
Method 2.3.1 — Determination of the total nitrogen in calcium cyanamide nitrate free	94
Method 2.3.2 — Determination of total nitrogen in calcium cyanamide containing nitrates	95
Method 2.3.3 — Determination of total nitrogen in urea	98
Method 2.4 — Determination of cyanamide nitrogen	99
Method 2.5 — Spectrophotometric determination of biuret in urea	101
Methods 2.6 — Determination of different forms of nitrogen in the same sample	104
Method 2.6.1 — Determination of different forms of nitrogen in the same sample in fertilisers containing nitrogen as nitric, ammoniacal, urea and cyanamide nitrogen	104

Method 2.6.2	— Determination of different forms of nitrogen in fertilisers containing nitrogen only as nitric, ammoniacal and urea nitrogen	116
Methods 3	— Phosphorus	122
Methods 3.1	— Extractions	122
Method 3.1.1	— Extraction of phosphorus soluble in mineral acids	122
Method 3.1.2	— Extraction of the phosphorus soluble in 2 % formic acid (20 g per litre)	123
Method 3.1.3	— Extraction of phosphorus soluble in 2 % citric acid (20 g per litre)	123
Method 3.1.4	— Extraction of phosphorus which is soluble in neutral ammonium citrate	124
Method 3.1.5	— Extraction by alkaline ammonium citrate	126
Method 3.1.5.1	— Extraction of soluble phosphorus according to petermann at 65 °C	126
Method 3.1.5.2	— Extraction of the soluble phosphorus according to Petermann at ambient temperature	128
Method 3.1.5.3	— Extraction of the phosphorus soluble in joulie's alkaline ammonium citrate	129
Method 3.1.6	— Extraction of water soluble phosphorus	130
Method 3.2	— Eetermination of extracted phosphorus (gravimetric method using quinoline phosphomolybdate)	131
Method 4	— Potassium	134
Method 4.1	— Determination of the water soluble potassium content	134
Method 5	—	137
Method 6	— Chlorine 116	137
Method 6.1	— Determination of chlorides in the absence of organic material	137
Methods 7	— Fineness of grinding	139
Method 7.1	— Determination of fineness of grinding (dry procedure)	139
Method 7.2	— Determination of the fineness of grinding of soft natural phosphates	140
Method 8	— Secondary nutrients	141
Method 8.1	— Extraction of total calcium, total magnesium, total sodium and total sulphur in the form of sulphates	141
Method 8.2	— Extraction of total sulphur present in various forms	142
Method 8.3	— Extraction of water-soluble calcium, magnesium, sodium and sulphur (in the form of sulphates)	143
Method 8.4	— Extraction of water-soluble sulphur where the sulphur is in various forms	144
Method 8.5	— Extraction and determination of elemental sulphur	145
Method 8.6	— Manganimetric determination of extracted calcium following precipitation in the form of oxalate	147
Method 8.7	— Determination of magnesium by atomic absorption spectrometry	148
Method 8.8	— Determination of magnesium by complexometry	150
Method 8.9	— Determination of sulphates	153
Method 8.10	— Determination of the sodium extracted	154

Methods 9	— Micro-nutrients at a concentration of less than or equal to 10 %	156
Method 9.1	— Extraction of total micro-nutrients	156
Method 9.2	— Extraction of water-soluble micro-nutrients	158
Method 9.3	— Removal of organic compounds from fertiliser extracts	159
Method 9.4	— Determination of micro-nutrients in fertiliser extracts by atomic absorption spectrometry (general procedure)	160
Method 9.5	— Determination of boron in fertiliser extracts by means of spectrometry with azomethine-H	162
Method 9.6	— Determination of cobalt in fertiliser extracts by atomic absorption spectrometry	164
Method 9.7	— Determination of copper in fertiliser extracts by atomic absorption spectrometry	166
Method 9.8	— Determination of iron in fertiliser extracts by atomic absorption spectrometry	167
Method 9.9	— Determination of manganese in fertiliser extracts by atomic absorption spectrometry	169
Method 9.10	— Determination of molybdenum in fertiliser extracts by spectrometry of a complex with ammonium thiocyanate	171
Method 9.11	— Determination of zinc in fertiliser extracts by atomic absorption spectrometry	173
Methods 10	— Micro-nutrients at a concentration greater than 10 %	175
Method 10.1	— Extraction of total micro-nutrients	175
Method 10.2	— Extraction of water-soluble micro-nutrients	176
Method 10.3	— Removal of organic compounds from fertiliser extracts	178
Method 10.4	— Determination of micro-nutrients in fertiliser extracts by atomic absorption spectrometry (general procedure)	179
Method 10.5	— Determination of boron in fertiliser extracts by means of acidimetric titration	181
Method 10.6	— Determination of cobalt in fertiliser extracts by the gravimetric method with 1-nitroso-2-naphthol	183
Method 10.7	— Determination of copper in fertiliser extracts by the titrimetric method	184
Method 10.8	— Determination of iron in fertiliser extracts by atomic absorption spectrometry	186
Method 10.9	— Determination of manganese in fertiliser extracts by titration	188
Method 10.10	— Determination of molybdenum in fertiliser extracts by the gravimetric method with 8-hydroxyquinoline	190
Method 10.11	— Determination of zinc in fertiliser extracts by atomic absorption spectrometry	191
ANNEX V		194
A. List of documents to be consulted by manufacturers or their representatives in order to compile a technical file for a new type of fertilisers to be added to annex I of this regulation.....		194
B. Standards of accreditation concerning the laboratories that are competent and authorised to provide the necessary service for checking compliance of EC fertilisers with the requirements of this regulation and its annexes		194

LIST OF TYPES OF EC FERTILISERS

A. Inorganic straight primary nutrient fertilisers

A.1. Nitrogenous fertilisers

No	Type designation	Data on method of production and essential ingredients	Minimum content of nutrients (percentage by weight) Data on the expression of nutrients Other requirements	Other data on the type designation	Nutrient content to be declared Forms and solubilities of the nutrients Other criteria
1	2	3	4	5	6
1(a)	Calcium nitrate (nitrate of lime)	Chemically obtained product containing calcium nitrate as its essential ingredient and possibly ammonium nitrate	15 % N Nitrogen expressed as total nitrogen or as nitric and ammoniacal nitrogen. Maximum content of ammoniacal nitrogen: 1,5 % N		Total nitrogen Additional optional particulars: Nitric nitrogen Ammoniacal nitrogen
1(b)	Calcium magnesium nitrate (nitrate of lime and magnesium)	Chemically obtained product containing calcium nitrate and magnesium nitrate as essential ingredients	13 % N Nitrogen expressed as nitric nitrogen. Minimum content of magnesium in the form of water-soluble salts expressed as magnesium oxide: 5 % MgO		Nitric nitrogen Water-soluble magnesium oxide
1(c)	Magnesium nitrate	Chemically obtained product containing as its essential ingredient hexahydrated magnesium nitrate	10 % N Nitrogen expressed as nitric nitrogen 14 % MgO Magnesium expressed as water-soluble magnesium oxide	When marketed in the form of crystals as note 'in crystallised form' may be added	Nitric nitrogen Water-soluble magnesium oxide
2(a)	Sodium nitrate (nitrate of soda)	Chemically obtained product containing sodium nitrate as its essential ingredient	15 % N Nitrogen expressed as nitric nitrogen		Nitric nitrogen
2(b)	Chile nitrate	Product prepared from caliche, containing sodium nitrate as its essential ingredient	15 % N Nitrogen expressed as nitric nitrogen		Nitric nitrogen
3(a)	Calcium cyanamide	Chemically obtained product containing calcium cyanamide as its essential ingredient, calcium oxide and possibly small quantities of ammonium salts and urea	18 % N Nitrogen expressed as total nitrogen, at least 75 % of the nitrogen declared being bound in the form of cyanamide		Total nitrogen

1	2	3	4	5	6
3(b)	Nitrogenous calcium cyanamide	Chemically obtained product containing calcium cyanamide as its essential ingredient, and calcium oxide and possibly small quantities of ammonium salts and urea, plus added nitrate	18 % N Nitrogen expressed as total nitrogen, at least 75 % of the non-nitric nitrogen declared being bound in the form of cyanamide. Nitric nitrogen content: — minimum: 1 % N — maximum: 3 % N		Total nitrogen Nitric nitrogen
4	Sulphate of ammonia	Chemically obtained product containing ammonium sulphate as its essential ingredient	20 % N Nitrogen expressed as ammoniacal nitrogen		Ammoniacal nitrogen
5	Ammonium nitrate or calcium ammonium nitrate	Chemically obtained product containing ammonium nitrate as its essential ingredient, which may contain fillers such as ground limestone, calcium sulphate, ground dolomite, magnesium sulphate, kieserite	20 % N Nitrogen expressed as nitric nitrogen and ammoniacal nitrogen, each of these two forms of nitrogen accounting for about half the nitrogen present. See Annexes III.1 and III.2 of this regulation, if required.	The designation 'calcium ammonium nitrate' is exclusively reserved for a fertiliser containing only calcium carbonate (for instance limestone) and/or magnesium carbonate and calcium carbonate (for instance dolomite) in addition to ammonium nitrate. The minimum content of these carbonates must be 20 % and their purity level at least 90 %	Total nitrogen Nitric nitrogen Ammoniacal nitrogen
6	Ammonium sulphate-nitrate	Chemically obtained product containing as essential ingredients ammonium nitrate and ammonium sulphate	25 % N Nitrogen expressed as ammoniacal and nitric nitrogen. Minimum nitric nitrogen content: 5 %		Total nitrogen Ammoniacal nitrogen Nitric nitrogen
7	Magnesium sulphonitrate	Chemically obtained product containing ammonium nitrate, ammonium sulphate and magnesium sulphate as essential ingredients	19 % N Nitrogen expressed as ammoniacal and nitric nitrogen. Minimum nitric nitrogen content: 6 % N 5 % MgO Magnesium in the form of water-soluble salts expressed as magnesium oxide		Total nitrogen Ammoniacal nitrogen Nitric nitrogen Water-soluble magnesium oxide
8	Magnesium ammonium nitrate	Chemically obtained product containing ammonium nitrates and magnesium compound salts (dolomite magnesium carbonate and/or magnesium sulphate) as essential ingredients	19 % N Nitrogen expressed as ammoniacal nitrogen and nitric nitrogen. Minimum nitric nitrogen content 6 % N 5 % MgO Magnesium expressed as total magnesium oxide		Total nitrogen Ammoniacal nitrogen Nitric nitrogen Total magnesium oxide and possibly, water-soluble magnesium oxide

1	2	3	4	5	6
9	Urea	Chemically obtained product containing carbonyl diamide (carbamide) as its essential ingredient	44 % N Total ureic nitrogen (including biuret). Maximum biuret content: 1,2 %		Total nitrogen, expressed as ureic nitrogen
10	Crotonylidene diurea	Product obtained by reaction of urea with crotonaldehyde Monomeric compound	28 % N Nitrogen expressed as total nitrogen At least 25 % N from the crotonylidene diurea Maximum ureic nitrogen content: 3 %		Total nitrogen Ureic nitrogen where this is at least 1 % by weight Nitrogen from crotonylidene diurea
11	Isobutylidene diurea	Product obtained by reaction of urea with isobutyraldehyde Monomeric compound	28 % N Nitrogen expressed as total nitrogen At least 25 % N from isobutylidene diurea Maximum ureic nitrogen content: 3 %		Total nitrogen Ureic nitrogen where this is at least 1 % by weight Nitrogen from isobutylidene diurea
12	Urea formaldehyde	Product obtained by reaction of urea with formaldehyde and containing as its essential ingredients molecules of urea formaldehyde Polymeric compound	36 % N total nitrogen Nitrogen expressed as total nitrogen At least 3/5 of the declared total nitrogen content must be soluble in hot water At least 31 % N from urea formaldehyde Maximum ureic nitrogen content: 5 %		Total nitrogen Ureic nitrogen where this is at least 1 % by weight Nitrogen from formaldehyde urea that is soluble in cold water Nitrogen from formaldehyde urea that is only soluble in hot water
13	Nitrogenous fertiliser containing crotonylidene diurea	Product obtained chemically containing crotonylidene diurea and a straight nitrogen fertiliser [List A-1, excluding products 3(a), 3(b) and 5]	18 % N expressed as total nitrogen At least 3 % nitrogen in ammoniacal and/or nitric and/or ureic form At least 1/3 of the declared total nitrogen content must be derived from crotonylidene diurea Maximum biuret content: (ureic N + crotonylidene diurea N) × 0,026		Total nitrogen For each form amounting to at least 1 %: — nitric nitrogen — ammoniacal nitrogen — ureic nitrogen Nitrogen from crotonylidene diurea

1	2	3	4	5	6
14	Nitrogenous fertiliser containing isobutylidene diurea	Product obtained chemically containing isobutylidene diurea and a straight nitrogenous fertiliser [List A-1, excluding products 3(a), 3(b) and 5]	<p>18 % N expressed as total nitrogen</p> <p>At least 3 % nitrogen in ammoniacal and/or nitric and/or ureic form</p> <p>A least 1/3 of the declared total nitrogen content must derive from isobutylidene diurea</p> <p>Maximum biuret content: (Ureic N + isobutylidene diurea N) × 0,026</p>		<p>Total nitrogen</p> <p>For each form amounting to at least 1 %:</p> <ul style="list-style-type: none"> — nitric nitrogen — ammoniacal nitrogen — ureic nitrogen <p>Nitrogen from isobutylidene diurea</p>
15	Nitrogenous fertiliser containing urea formaldehyde	Product obtained chemically containing urea formaldehyde and a straight nitrogenous fertiliser [List A-1, excluding products 3(a), 3(b) and 5]	<p>18 % N expressed as total nitrogen</p> <p>At least 3 % nitrogen in ammoniacal and/or nitric and/or ureic form</p> <p>At least 1/3 of the declared total nitrogen content must derive from urea formaldehyde</p> <p>The nitrogen from the urea formaldehyde must contain at least 3/5 nitrogen that is soluble in hot water</p> <p>Maximum biuret content: (Ureic N + urea formaldehyde) × 0,026</p>		<p>Total nitrogen</p> <p>For each form amounting to at least 1 %:</p> <ul style="list-style-type: none"> — nitric nitrogen — ammoniacal nitrogen — ureic nitrogen <p>Nitrogen from urea formaldehyde</p> <p>Nitrogen from urea formaldehyde that is soluble in cold water</p> <p>Nitrogen from urea formaldehyde that is only soluble in hot water</p>
16	Ammonium sulphate with nitrification inhibitor (dicyandiamide)	Chemically obtained product containing ammonium sulphate and dicyandiamide	<p>20 % N</p> <p>Nitrogen expressed as total nitrogen</p> <p>Minimum ammoniacal nitrogen content: 18 %</p> <p>Minimum content of nitrogen from dicyandiamide: 1,5 %</p>		<p>Total nitrogen</p> <p>Ammoniacal nitrogen</p> <p>Nitrogen from dicyandiamide</p> <p>Technical information (a)</p>
17	Ammonium sulphonitrate with nitrification inhibitor (dicyandiamide)	Chemically obtained product containing ammonium sulphonitrate and dicyandiamide	<p>24 % N</p> <p>Nitrogen expressed as total nitrogen</p> <p>Minimum nitric nitrogen content: 3 %</p> <p>Minimum content of nitrogen from dicyandiamide: 1,5 %</p>		<p>Total nitrogen</p> <p>Nitric nitrogen</p> <p>Ammoniacal nitrogen</p> <p>Nitrogen from dicyandiamide</p> <p>Technical information (a)</p>

1	2	3	4	5	6
18	Urea-ammonium sulphate	Product obtained chemically from urea and ammonium sulphate	30 % N Nitrogen expressed as ammoniacal and ureic nitrogen Minimum ammoniacal nitrogen content: 4 % Minimum sulphur content expressed as sulphur trioxide: 12 % Maximum biuret content: 0,9 %		Total nitrogen Ammoniacal nitrogen Ureic nitrogen Water-soluble sulphur trioxide

(a) Technical information as complete as possible must be provided with each package or bulk consignment by the person responsible for marketing. This information must in particular enable the user to determine the rates and timing of application in relation to the crop being grown.

A.2. Phosphatic fertilisers

Where a particle size criterion is prescribed for the basic constituent materials of fertilisers sold in granular form (fertilisers 1, 3, 4, 5, 6 and 7), it will be established by an appropriate analytical method.

No	Type designation	Data on method of production and essential ingredients	Minimum content of nutrients (percentage by weight) Data on the expression of nutrients Other requirements	Other data on the type designation	Nutrient content to be declared Forms and solubilities of the nutrients Other criteria
1	2	3	4	5	6
1	Basic slag: — Thomas phosphates — Thomas slag	Product obtained in iron-smelting by treatment of the phosphorus melts and containing calcium silicophosphates as its essential ingredients	12 % P ₂ O ₅ Phosphorus expressed as phosphorus pentoxide soluble in mineral acids, at least 75 % of the declared content of phosphorus pentoxide being soluble in 2 % citric acid or P ₂ O ₅ Phosphorus expressed as phosphorus pentoxide soluble in 2 % citric acid Particle size: — at least 75 % able to pass through a sieve with a mesh of 0,160 mm — at least 96 % able to pass through a sieve with a mesh of 0,630 mm		Total phosphorus pentoxide (soluble in mineral acids) 75 % of which (to be indicated as % by weight) is soluble in 2 % citric acid (for marketing in France, Italy, Spain, Portugal and Greece) Total phosphorus pentoxide (soluble in mineral acids) and phosphorus pentoxide soluble in 2 % citric acid (for marketing in the United Kingdom) Phosphorus pentoxide soluble in 2 % citric acid (for marketing in Germany, Belgium, Denmark, Ireland, Luxembourg, the Netherlands and Austria)

1	2	3	4	5	6
2(a)	Single superphosphate	Product obtained by reaction of ground mineral phosphate with sulphuric acid and containing monocalcium phosphate as an essential ingredient as well as calcium sulphate	16 % P ₂ O ₅ Phosphorus expressed as P ₂ O ₅ soluble in neutral ammonium citrate, at least 93 % of the declared content of P ₂ O ₅ being water-soluble Test sample: 1 g		Phosphorus pentoxide soluble in neutral ammonium citrate Water-soluble phosphorus pentoxide
2(b)	Concentrated superphosphate	Product obtained by reaction of ground mineral phosphate with sulphuric acid and phosphoric acid and containing monocalcium phosphate as an essential ingredient as well as calcium sulphate	25 % P ₂ O ₅ Phosphorus expressed as P ₂ O ₅ soluble in neutral ammonium citrate, at least 93 % of the declared content of P ₂ O ₅ being water-soluble Test sample: 1 g		Phosphorus pentoxide soluble in neutral ammonium citrate Water-soluble phosphorus pentoxide
2(c)	Triple superphosphate	Product obtained by reaction of ground mineral phosphate with phosphoric acid and containing monocalcium phosphate as its essential ingredient	38 % P ₂ O ₅ Phosphorus expressed as P ₂ O ₅ soluble in neutral ammonium citrate, at least 93 % of the declared content of P ₂ O ₅ being water-soluble Test sample: 3 g		Phosphorus pentoxide soluble in neutral ammonium citrate Water-soluble phosphorus pentoxide
3	Partially solubilised rock phosphate	Product obtained by partial solubilisation of ground rock phosphate with sulphuric acid or phosphoric acid and containing as essential ingredients monocalcium phosphate, tricalcium phosphate and calcium sulphate	20 % P ₂ O ₅ Phosphorus expressed as P ₂ O ₅ soluble in mineral acids, at least 40 % of the declared content of P ₂ O ₅ being water-soluble Particle size: — at least 90 % able to pass through a sieve with a mesh of 0,160 mm — at least 98 % able to pass through a sieve with a mesh of 0,630 mm		Total phosphorus pentoxide (soluble in mineral acids) Phosphorus pentoxide soluble in water
4	Dicalcium phosphate	Product obtained by precipitation of solubilised phosphoric acid from mineral phosphates or bones, and containing dicalcium phosphate dihydrate as its essential ingredient	38 % P ₂ O ₅ Phosphorus expressed as P ₂ O ₅ soluble in alkaline ammonium citrate (Petermann) Particle size: — at least 90 % able to pass through a sieve with a mesh of 0,160 mm — at least 98 % able to pass through a sieve with a mesh of 0,630 mm		Phosphorus pentoxide soluble in alkaline ammonium citrate

1	2	3	4	5	6
5	Calcined phosphate	Product obtained by heat treatment of ground rock phosphate with alkaline compounds and silicic acid, and containing alkaline calcium phosphate and calcium silicate as essential ingredients	<p>25 % P₂O₅ Phosphorus expressed as P₂O₅ soluble in alkaline ammonium citrate (Petermann)</p> <p>Particle size:</p> <ul style="list-style-type: none"> — at least 75 % able to pass through a sieve with a mesh of 0,160 mm — at least 96 % able to pass through a sieve with a mesh of 0,630 mm 		Phosphorus pentoxide soluble in alkaline ammonium citrate
6	Aluminium-calcium phosphate	Product obtained in amorphous form by heat treatment and grinding, containing aluminium and calcium phosphates as essential ingredients	<p>30 % P₂O₅ Phosphorus expressed as P₂O₅ soluble in mineral acids, at least 75 % of the declared content of P₂O₅ being soluble in alkaline ammonium citrate (Joulié)</p> <p>Particle size:</p> <ul style="list-style-type: none"> — at least 90 % able to pass through a sieve with a mesh of 0,160 mm — at least 98 % able to pass through a sieve with a mesh of 0,630 mm 		<p>Total phosphorus pentoxide (soluble in mineral acids)</p> <p>Phosphorus pentoxide soluble in alkaline ammonium citrate</p>
7	Soft ground rock phosphate	Product obtained by grinding soft mineral phosphates and containing tricalcium phosphate and calcium carbonate as essential ingredients	<p>25 % P₂O₅ Phosphorus expressed as P₂O₅ soluble in mineral acids, at least 55 % of the declared content of P₂O₅ being soluble in 2 % formic acid</p> <p>Particle size:</p> <ul style="list-style-type: none"> — at least 90 % able to pass through a sieve with a mesh of 0,063 mm — at least 99 % able to pass through a sieve with a mesh of 0,125 mm 		<p>Total phosphorus pentoxide (soluble in mineral acids)</p> <p>Phosphorus pentoxide soluble in 2 % formic acid</p> <p>Percentage by weight of material able to pass through a sieve with a mesh of 0,063 mm</p>

A.3. Potassic fertilisers

No	Type designation	Data on method of production and essential ingredients	Minimum content of nutrients (percentage by weight) Data on the expression of nutrients Other requirements	Other data on the type designation	Nutrient content to be declared Forms and solubilities of the nutrients Other criteria
1	2	3	4	5	6
1	Kainit	Product obtained from crude potassium salts	10 % K ₂ O Potassium expressed as water-soluble K ₂ O 5 % MgO Magnesium in the form of water-soluble salts, expressed as magnesium oxide	Usual trade names may be added	Water-soluble potassium oxide Water-soluble magnesium oxide
2	Enriched kainit salt	Product obtained from crude potassium salts enriched by blending with potassium chloride	18 % K ₂ O Potassium expressed as water-soluble K ₂ O	Usual trade names may be added	Water-soluble potassium oxide Optional mention of the water-soluble magnesium oxide content where higher than 5 % MgO
3	Muriate of potash	Product obtained from crude potassium salts and containing potassium chloride as its essential ingredient	37 % K ₂ O Potassium expressed as water-soluble K ₂ O	Usual trade names may be added	Water-soluble potassium oxide
4	Potassium chloride containing magnesium salts	Product obtained from crude potassium salts with added magnesium salts and containing potassium chloride and magnesium salts as essential ingredients	37 % K ₂ O Potassium expressed as water-soluble K ₂ O 5 % MgO Magnesium in the form of water-soluble salts, expressed as magnesium oxide		Water-soluble potassium oxide Water-soluble magnesium oxide
5	Sulphate of potash	Product obtained chemically from potassium salts and containing potassium sulphate as its essential ingredient	47 % K ₂ O Potassium expressed as water-soluble K ₂ O Maximum chloride content: 3 % Cl		Water-soluble potassium oxide Optional mention of the chloride content

1	2	3	4	5	6
6	Sulphate of potash containing magnesium salt	Product obtained chemically from potassium salts, possibly with addition of magnesium salts, and containing potassium sulphate and magnesium sulphate as essential ingredients	22 % K ₂ O Potassium expressed as water-soluble K ₂ O 8 % MgO Magnesium in the form of water-soluble salts, expressed as magnesium oxide Maximum chloride content: 3 % Cl	Usual trade names may be added	Water-soluble potassium oxide Water-soluble magnesium oxide Optional mention of the chloride content
7	Kieserite with potassium sulphate	Product obtained from Kieserite with potassium sulphate added	8 % MgO Magnesium expressed as water-soluble MgO 6 % K ₂ O Potassium expressed as water-soluble K ₂ O Total MgO + K ₂ O: 20 % Maximum chloride content: 3 % Cl	Usual trade names may be added	Water-soluble magnesium oxide Water-soluble potassium oxide Optional mention of the chloride content

B. Inorganic compound primary nutrient fertilisers

B.1. NPK fertilisers

	Type designation:	NPK fertilisers.
B.1.1.	Data on method of production:	Product obtained chemically or by blending, without addition of organic nutrients of animal or vegetable origin.
	Minimum content of nutrients (percentage by weight):	— Total: 20 % (N + P ₂ O ₅ + K ₂ O); — For each of the nutrients: 3 % N, 5 % P ₂ O ₅ , 5 % K ₂ O.

Forms, solubilities and nutrient content to be declared as specified in columns 4, 5 and 6 Particle size			Data for identification of the fertilisers Other requirements		
N	P ₂ O ₅	K ₂ O	N	P ₂ O ₅	K ₂ O
1	2	3	4	5	6
(1) Total nitrogen	(1) Water-soluble P ₂ O ₅	Water soluble K ₂ O	(1) Total nitrogen	<p>1. An NPK fertiliser free from Thomas slag, calcined phosphate, aluminium-calcium phosphate, partially solubilised rock phosphate and soft ground rock phosphate must be declared in accordance with solubilities (1), (2) or (3):</p> <ul style="list-style-type: none"> — when the water-soluble P₂O₅ does not amount to 2 %, solubility (2) only shall be declared; — when the water-soluble P₂O₅ is at least 2 %, solubility (3) shall be declared, and the water-soluble P₂O₅ content must be indicated [solubility (1)]. <p>The P₂O₅ content soluble in mineral acids only must not exceed 2 %.</p> <p>For this type 1, the test sample for determining solubilities (2) and (3) shall be 1 g.</p> <p>2 (a) An NPK fertiliser containing soft ground rock phosphate or partially solubilised rock phosphate must be free from Thomas slag, calcined phosphate and aluminium-calcium phosphate. It shall be declared in accordance with solubilities (1), (3) and (4)</p> <p>This type of fertiliser must contain:</p> <ul style="list-style-type: none"> — at least 2 % P₂O₅ soluble in mineral acids only [solubility (4)]; — at least 5 % P₂O₅ soluble in water and neutral ammonium citrate [solubility (3)]; — at least 2,5 % water-soluble P₂O₅ [solubility (1)]. <p>This type of fertiliser must be marketed under the designation 'NPK fertiliser containing soft ground rock phosphate' or 'NPK fertiliser containing partially solubilised rock phosphate'. For this type 2(a), the test sample for determining solubility (3) shall be 3 g.</p>	(1) Water-soluble potassium oxide
(2) Nitric nitrogen	(2) P ₂ O ₅ soluble in neutral ammonium citrate		(2) If any of the forms of nitrogen (2) to (5) amounts to at least 1 % by weight, it must be declared		(2) The indication 'low in chloride' is linked to a maximum content of 2 % Cl
(3) Ammoniacal nitrogen	(3) P ₂ O ₅ soluble in neutral ammonium citrate and in water		(3) If above 28 %, see Annex III.2		(3) Chloride content may be declared
(4) Ureic nitrogen	(4) P ₂ O ₅ soluble in mineral acids only				
(5) Cyanamide nitrogen	(5) P ₂ O ₅ soluble in alkaline ammonium citrate (Petermann)				
	(6a) P ₂ O ₅ soluble in mineral acids, of which at least 75 % of the declared P ₂ O ₅ content is soluble in 2 % citric acid				
	(6b) P ₂ O ₅ soluble in 2 % citric acid				
	(7) P ₂ O ₅ soluble in mineral acids, of which at least 75 % of the declared P ₂ O ₅ content is soluble in alkaline ammonium citrate (Joulie)				
	(8) P ₂ O ₅ soluble in mineral acids, of which at least 55 % of the declared P ₂ O ₅ content is soluble in 2 % formic acid				

1	2	3	4	5	6
<p>Particle size of the basic phosphatic ingredients</p> <p>Thomas slag:</p> <p>Aluminium-calcium phosphate:</p> <p>Calcined phosphate:</p> <p>Soft ground rock phosphate:</p> <p>Partially solubilised rock phosphate:</p>	<p>at least 75 % able to pass through a sieve with a mesh of 0,160 mm</p> <p>at least 90 % able to pass through a sieve with a mesh of 0,160 mm</p> <p>at least 75 % able to pass through a sieve with a mesh of 0,160 mm</p> <p>at least 90 % able to pass through a sieve with a mesh of 0,063 mm</p> <p>at least 90 % able to pass through a sieve with a mesh of 0,160 mm</p>			<p>2 (b) An NPK fertiliser containing aluminium-calcium phosphate must be free from Thomas slag, calcined phosphate, soft ground rock phosphate and partially solubilised rock phosphate.</p> <p>It shall be declared in accordance with solubilities (1) and (7), the latter applying after deduction of the solubility in water.</p> <p>This type of fertiliser must contain:</p> <ul style="list-style-type: none"> — at least 2 % of water-soluble P₂O₅ [solubility (1)]; — at least 5 % of P₂O₅ according to solubility (7). <p>This type of fertiliser must be marketed under the designation 'NPK fertiliser containing aluminium-calcium phosphate'.</p> <p>3. In the case of NPK fertilisers containing only one of the following types of phosphatic fertiliser: Thomas slag, calcined phosphate, aluminium-calcium phosphate, soft ground rock phosphate, the type designation must be followed by an indication of the phosphate ingredient.</p> <p>The declaration of the solubility of the P₂O₅ must be given in accordance with the following solubilities:</p> <ul style="list-style-type: none"> — for fertilisers based on Thomas slag: solubility (6a) (France, Italy, Spain, Portugal, Greece), (6b) (Germany, Belgium, Denmark, Ireland, Luxembourg, Netherlands, United Kingdom and Austria); — for fertilisers based on calcined phosphate: solubility (5); — for fertilisers based on aluminium-calcium phosphate: solubility (7); — for fertilisers based on soft ground rock phosphate: solubility (8). 	

B.1. NPK fertilisers (cont'd)

B.1.2.	Type designation:	NPK fertiliser containing crotonylidene diurea or isobutylidene diurea or urea formaldehyde (as appropriate).
	Data on method of production:	Product obtained chemically without addition of organic nutrients of animal or vegetable origin and containing crotonylidene diurea or isobutylidene diurea or urea formaldehyde.
	Minimum content of nutrients (percentage by weight):	<ul style="list-style-type: none"> — Total: 20 % (N + P₂O₅ + K₂O); — For each of the nutrients: <ul style="list-style-type: none"> — 5 % N. At least ¼ of the declared content of total nitrogen must derive from nitrogen form (5) or (6) or (7). At least 3/5 of the declared nitrogen content (7) must be soluble in hot water, — 5 % P₂O₅, — 5 % K₂O.

Forms, solubilities and nutrient content to be declared as specified in columns 4, 5 and 6 Particle size			Data for identification of the fertilisers Other requirements		
N	P ₂ O ₅	K ₂ O	N	P ₂ O ₅	K ₂ O
1	2	3	4	5	6
(1) Total nitrogen (2) Nitric nitrogen (3) Ammoniacal nitrogen (4) Ureic nitrogen (5) Nitrogen from crotonylidene diurea (6) Nitrogen from isobutylidene diurea (7) Nitrogen from urea formaldehyde (8) Nitrogen from urea formaldehyde that is only soluble in hot water (9) Nitrogen from urea formaldehyde that is soluble in cold water	(1) Water-soluble P ₂ O ₅ (2) P ₂ O ₅ soluble in neutral ammonium citrate (3) P ₂ O ₅ soluble in neutral ammonium citrate and in water	Water-soluble K ₂ O	(1) Total nitrogen (2) If any of the forms of nitrogen (2) to (4) amounts to at least 1 % by weight, it must be declared (3) One of the forms of nitrogen (5) to (7) (as appropriate). Nitrogen form (7) must be declared in the form of nitrogen (8) and (9)	An NPK fertiliser free from Thomas slag, calcined phosphate, aluminium-calcium phosphate, partially solubilised rock phosphate and rock phosphate must be declared in accordance with solubilities (1), (2) or (3): — when the water-soluble P ₂ O ₅ does not amount to 2 %, solubility (2) only shall be declared, — when the water-soluble P ₂ O ₅ is at least 2 %, solubility (3) shall be declared, and the water-soluble P ₂ O ₅ content must be indicated [solubility (1)]. The P ₂ O ₅ content soluble in mineral acids only must not exceed 2 %. The test sample for determining solubilities (2) and (3) shall be 1 g.	(1) Water-soluble potassium oxide (2) The indication 'low in chloride' is linked to a maximum content of 2 % Cl (3) Chloride content may be declared

B.2. NP fertilisers

B.2.1.	Type designation:	NP fertilisers.
	Data on method of production:	Product obtained chemically or by blending without addition of organic nutrients of animal or vegetable origin.
	Minimum content of nutrients (percentage by weight):	— Total: 18 % (N + P ₂ O ₅); — For each of the nutrients: 3 % N, 5 % P ₂ O ₅ .

Forms, solubilities and nutrient content to be declared as specified in columns 4, 5 and 6 Particle size			Data for identification of the fertilisers Other requirements		
N	P ₂ O ₅	K ₂ O	N	P ₂ O ₅	K ₂ O
1	2	3	4	5	6
(1) Total nitrogen (2) Nitric nitrogen (3) Ammoniacal nitrogen (4) Ureic nitrogen (5) Cyanamide nitrogen	(1) Water-soluble P ₂ O ₅ (2) P ₂ O ₅ soluble in neutral ammonium citrate (3) P ₂ O ₅ soluble in neutral ammonium citrate and in water (4) P ₂ O ₅ soluble in mineral acids only (5) P ₂ O ₅ soluble in alkaline ammonium citrate (Petermann) (6a) P ₂ O ₅ soluble in mineral acids, of which at least 75 % of the declared P ₂ O ₅ content is soluble in 2 % citric acid (6b) P ₂ O ₅ soluble in 2 % citric acid (7) P ₂ O ₅ soluble in mineral acids of which at least 75 % of the declared P ₂ O ₅ content is soluble in alkaline ammonium citrate (Joulié) (8) P ₂ O ₅ soluble in mineral acids of which at least 55 % of the declared P ₂ O ₅ content is soluble in 2 % formic acid		(1) Total nitrogen (2) If any of the forms of nitrogen (2) to (5) amounts to at least 1 % by weight, it must be declared	1. An NP fertiliser free from Thomas slag, calcined phosphate, aluminium-calcium phosphate, partially solubilised rock phosphate and soft ground rock phosphate must be declared in accordance with solubilities (1), (2) or (3): — when the water-soluble P ₂ O ₅ does not amount to 2 %, solubility (2) only shall be declared; — when the water-soluble P ₂ O ₅ is at least 2 %, solubility (3) shall be declared, and the water-soluble P ₂ O ₅ content must be indicated [solubility (1)]. The P ₂ O ₅ content soluble in mineral acids only must not exceed 2 %. For this type 1, the test sample for determining solubilities (2) and (3) shall be 1 g. 2 (a) A NP fertiliser containing soft ground rock phosphate or partially solubilised rock phosphate must be free from Thomas slag, calcined phosphate and aluminium-calcium phosphate. It shall be declared in accordance with solubilities (1), (3) and (4). This type of fertiliser must contain: — at least 2 % P ₂ O ₅ soluble in mineral acids only [solubility (4)]; — at least 5 % P ₂ O ₅ soluble in water and neutral ammonium citrate [solubility (3)];	

1	2	3	4	5	6
<p>Particle size of the basic phosphatic ingredients:</p> <p>Thomas slag</p> <p>Aluminium-calcium phosphate</p> <p>Calcined phosphate</p> <p>Soft ground rock phosphate</p> <p>Partially solubilised rock phosphate</p>	<p>at least 75 % able to pass through a sieve with a mesh of 0,160 mm</p> <p>at least 90 % able to pass through a sieve with a mesh of 0,160 mm</p> <p>at least 75 % able to pass through a sieve with a mesh of 0,160 mm</p> <p>at least 90 % able to pass through a sieve with a mesh of 0,063 mm</p> <p>at least 90 % able to pass through a sieve with a mesh of 0,160 mm</p>			<p>— at least 2,5 % water soluble P₂O₅ [solubility (1)].</p> <p>This type of fertiliser must be marketed under the designation 'NP fertiliser containing soft ground rock phosphate' or 'NP fertiliser containing partially solubilised rock phosphate'.</p> <p>For this type 2(a), the test sample for determining solubility (3) shall be 3 g.</p> <p>2 (b) A NP fertiliser containing aluminium-calcium phosphate, must be free from Thomas slag, calcined phosphate, soft ground rock phosphate and partially solubilised rock phosphate.</p> <p>It shall be declared in accordance with solubilities (1) and (7), the latter applying after deduction of the solubility in water.</p> <p>This type of fertiliser must contain:</p> <p>— at least 2 % water-soluble P₂O₅ [solubility (1)];</p> <p>— at least 5 % P₂O₅ according to solubility (7).</p> <p>This type of fertiliser must be marketed under the designation 'NP fertiliser containing aluminium-calcium phosphate'.</p> <p>3. In the case of NP fertilisers containing only one of the following types of phosphatic fertiliser: Thomas slag, calcined phosphate, aluminium-calcium phosphate, soft ground rock phosphate, the type designation must be followed by an indication of the phosphate ingredient.</p> <p>The declaration of the solubility of the P₂O₅ must be given in accordance with the following solubilities:</p> <p>— for fertilisers based on Thomas slag: solubility (6a) (France, Italy, Spain, Portugal, Greece), (6b) (Germany, Belgium, Denmark, Ireland, Luxembourg, Netherlands, United Kingdom and Austria);</p>	

1	2	3	4	5	6
				<ul style="list-style-type: none"> — for fertilisers based on calcined phosphate: solubility (5); — for fertilisers based on aluminium-calcium phosphate: solubility (7); — for fertilisers based on soft ground rock phosphate: solubility (8). 	

B.2. NP fertilisers (cont'd)

B.2.2.	Type designation:	NP fertiliser containing crotonylidene diurea or isobutylidene diurea or urea formaldehyde (as appropriate)
	Data on method of production:	Product obtained chemically without addition of organic nutrients of animal or vegetable origin and containing crotonylidene diurea or isobutylidene diurea or urea formaldehyde
	Minimum content of nutrients (percentage by weight):	<ul style="list-style-type: none"> — Total: 18 % (N + P₂O₅); — For each of the nutrients: <ul style="list-style-type: none"> — 5 % N. At least ¼ of the declared content of total nitrogen must derive from nitrogen form (5) or (6) or (7). At least 3/5 of the declared nitrogen content (7) must be soluble in hot water, — 5 % P₂O₅.

Forms, solubilities and nutrient content to be declared as specified in columns 4, 5 and 6 Particle size			Data for identification of the fertilisers Other requirements		
N	P ₂ O ₅	K ₂ O	N	P ₂ O ₅	K ₂ O
1	2	3	4	5	6
(1) Total nitrogen	(1) Water-soluble P ₂ O ₅		(1) Total nitrogen	An NP fertiliser free of Thomas slag, calcined phosphate, aluminium-calcium phosphate, partially solubilised rock phosphate and rock phosphate must be declared in accordance with solubilities (1), (2) or (3): <ul style="list-style-type: none"> — when the water-soluble P₂O₅ does not amount to 2 %, solubility (2) only shall be declared; — when the water-soluble P₂O₅ is at least 2 %, solubility (3) shall be declared, and the water-soluble P₂O₅ content must be indicated [solubility (1)]. 	
(2) Nitric nitrogen	(2) P ₂ O ₅ soluble in neutral ammonium citrate		(2) If any of the forms of nitrogen (2) to (4) amounts to at least 1 % by weight, it must be declared		
(3) Ammoniacal nitrogen	(3) P ₂ O ₅ soluble in neutral ammonium citrate and in water		(3) One of the forms of nitrogen (5) to (7) (as appropriate). Nitrogen form (7) must be declared in the form of nitrogen (8) and (9)		
(4) Ureic nitrogen					
(5) Nitrogen from crotonylidene diurea					
(6) Nitrogen from isobutylidene diurea					
(7) Nitrogen from urea formaldehyde					

1	2	3	4	5	6
(8) Nitrogen from urea formaldehyde that is only soluble in hot water				The P ₂ O ₅ content soluble in mineral acids only must not exceed 2 %. The test sample for determining solubilities (2) and (3) shall be 1 g.	
(9) Nitrogen from urea formaldehyde that is soluble in cold water					

B.3. NK fertilisers

B.3.1.	Type designation:	NK fertilisers.
	Data on method of production:	Product obtained chemically or by blending, without addition of organic nutrients of animal or vegetable origin.
	Minimum content of nutrients (percentage by weight):	— Total: 18 % (N + K ₂ O); — For each of the nutrients: 3 % N, 5 % K ₂ O.

Forms, solubilities and nutrient content to be declared as specified in columns 4, 5 and 6 Particle size			Data for identification of the fertilisers Other requirements		
N	P ₂ O ₅	K ₂ O	N	P ₂ O ₅	K ₂ O
1	2	3	4	5	6
(1) Total nitrogen (2) Nitric nitrogen (3) Ammoniacal nitrogen (4) Ureic nitrogen (5) Cyanamide nitrogen		Water-soluble K ₂ O	(1) Total nitrogen (2) If any of the forms of nitrogen (2) to (5) amounts to at least 1 % by weight, it must be declared		(1) Water-soluble potassium oxide (2) The indication 'low in chloride' is linked to a maximum content of 2 % Cl (3) Chloride content may be declared

B.3. NK fertilisers (cont'd)

B.3.2.	Type designation:	NK fertiliser containing crotonylidene diurea or isobutylidene diurea or urea formaldehyde (as appropriate).
	Data on method of production:	Product obtained chemically without addition of organic nutrients of animal or vegetable origin and containing crotonylidene diurea or isobutylidene diurea or urea formaldehyde.
	Minimum content of nutrients (percentage by weight):	<ul style="list-style-type: none"> — Total: 18 % (N + K₂O); — For each of the nutrients: <ul style="list-style-type: none"> — 5 % N At least ¼ of the declared content of total nitrogen must derive from nitrogen form (5) or (6) or (7). At least 3/5 of the declared nitrogen content (7) must be soluble in hot water, — 5 % K₂O.

Forms, solubilities and nutrient content to be declared as specified in columns 4, 5 and 6 Particle size			Data for identification of the fertilisers Other requirements		
N	P ₂ O ₅	K ₂ O	N	P ₂ O ₅	K ₂ O
1	2	3	4	5	6
(1) Total nitrogen (2) Nitric nitrogen (3) Ammoniacal nitrogen (4) Ureic nitrogen (5) Nitrogen from crotonylidene diurea (6) Nitrogen from isobutylidene diurea (7) Nitrogen from urea formaldehyde (8) Nitrogen from urea formaldehyde that is only soluble in hot water (9) Nitrogen from urea formaldehyde that is soluble in cold water		Water-soluble K ₂ O	(1) Total nitrogen (2) If any of the forms of nitrogen (2) to (4) amounts to at least 1 % by weight, it must be declared (3) One of the forms of nitrogen (5) to (7) (as appropriate). Nitrogen form (7) must be declared in the form of nitrogen (8) and (9)		(1) Water-soluble potassium oxide (2) The indication 'low in chloride' is linked to a maximum content of 2 % Cl (3) Chloride content may be declared

B.4. PK fertilisers

Type designation:	PK fertilisers.
Data on method of production:	Product obtained chemically or by blending, without addition of organic nutrients of animal or vegetable origin.
Minimum content of nutrients (percentage by weight):	<ul style="list-style-type: none"> — Total: 18 % (P₂O₅ + K₂O); — For each of the nutrients: 5 % P₂O₅, 5 % K₂O.

Forms, solubilities and nutrient content to be declared as specified in columns 4, 5 and 6 Particle size			Data for identification of the fertilisers Other requirements		
N	P ₂ O ₅	K ₂ O	N	P ₂ O ₅	K ₂ O
1	2	3	4	5	6
	<ul style="list-style-type: none"> (1) Water-soluble P₂O₅ (2) P₂O₅ soluble in neutral ammonium citrate (3) P₂O₅ soluble in neutral ammonium citrate and in water (4) P₂O₅ soluble in mineral acids only (5) P₂O₅ soluble in alkaline ammonium citrate (Petermann) (6a) P₂O₅ soluble in mineral acids, of which at least 75 % of the declared P₂O₅ content is soluble in 2 % citric acid (6b) P₂O₅ soluble in 2 % citric acid (7) P₂O₅ soluble in mineral acids of which at least 75 % of the declared P₂O₅ content is soluble in alkaline ammonium citrate (Joulié) (8) P₂O₅ soluble in mineral acids, of which at least 55 % of the declared P₂O₅ content is soluble in 2 % formic acid 	Water soluble K ₂ O		<p>1. A PK fertiliser free from Thomas slag, calcined phosphate, aluminium-calcium phosphate, partially solubilised rock phosphate and soft ground rock phosphate must be declared in accordance with solubilities (1), (2) or (3):</p> <ul style="list-style-type: none"> — when the water-soluble P₂O₅ does not amount to 2 % solubility (2) only shall be declared; — when the water-soluble P₂O₅ is at least 2 % solubility (3) shall be declared and the water-soluble P₂O₅ content must be indicated [solubility (1)]. <p>The P₂O₅ content soluble in mineral acids only must not exceed 2 %.</p> <p>For this type 1, the test sample for determining solubilities (2) and (3) shall be 1 g.</p> <p>2 (a) A PK fertiliser containing soft ground rock phosphate or partially solubilised rock phosphate must be free from Thomas slag, calcined phosphate and aluminium-calcium phosphate.</p> <p>It shall be declared in accordance with solubilities (1), (3) and (4)</p> <p>This type of fertiliser must contain:</p> <ul style="list-style-type: none"> — at least 2 % P₂O₅ soluble in mineral acids only [solubility (4)]; — at least 5 % P₂O₅ soluble in water and neutral ammonium citrate [solubility (3)]; — at least 2,5 % water-soluble P₂O₅ [solubility (1)]. 	<ul style="list-style-type: none"> (1) Water-soluble potassium oxide (2) The indication 'low in chloride' is linked to a maximum content of 2 % Cl (3) Chloride content may be declared

1	2	3	4	5	6
<p>Particle size of the basic phosphatic ingredients:</p> <p>Thomas slag</p> <p>Aluminium-calcium phosphate</p> <p>Calcined phosphate</p> <p>Soft ground rock phosphate</p> <p>Partially solubilised rock phosphate</p>	<p>at least 75 % able to pass through a sieve with a mesh of 0,160 mm</p> <p>at least 90 % able to pass through a sieve with a mesh of 0,160 mm</p> <p>at least 75 % able to pass through a sieve with a mesh of 0,160 mm</p> <p>at least 90 % able to pass through a sieve with a mesh of 0,063 mm</p> <p>at least 90 % able to pass through a sieve with a mesh of 0,160 mm</p>			<p>This type of fertiliser must be marketed under the designation 'PK fertiliser containing soft ground rock phosphate' or 'PK fertiliser containing partially solubilised rock phosphate'.</p> <p>For this type 2(a), the test sample for determining solubility (3) shall be 3 g</p> <p>2 (b) A PK fertiliser containing aluminium-calcium phosphate must be free from Thomas slag, calcined phosphate and partially solubilised rock phosphate.</p> <p>It shall be declared in accordance with solubilities (1) and (7), the latter applying after deduction of the solubility in water.</p> <p>This type of fertiliser must contain:</p> <ul style="list-style-type: none"> — at least 2 % water-soluble P₂O₅ [solubility (1)]; — at least 5 % P₂O₅ according to solubility (7). <p>This type of fertiliser must be marketed under the designation 'PK fertiliser containing aluminium-calcium phosphate'.</p> <p>3. In the case of PK fertilisers containing only one of the following types of phosphatic fertiliser: Thomas slag, calcined phosphate, aluminium-calcium phosphate, soft ground rock phosphate, the type designation must be followed by an indication of the phosphate ingredient.</p> <p>The declaration of the solubility of the P₂O₅ must be given in accordance with the following solubilities:</p> <ul style="list-style-type: none"> — for fertilisers based on Thomas slag: solubility (6a) (France, Italy, Spain, Portugal, Greece), (6b) (Germany, Belgium, Denmark, Ireland, Luxembourg, Netherlands, United Kingdom and Austria); — for fertilisers based on calcined phosphate: solubility (5); — for fertilisers based on aluminium-calcium phosphate: solubility (7); — for fertilisers based on soft ground rock phosphate: solubility (8). 	

C. Inorganic fluid fertilisers

C.1. Straight fluid fertilisers

No	Type designation	Data on method of production and essential ingredients	Minimum content of nutrients (percentage by weight) Data on the expression of nutrients Other requirements	Other data or type designation	Nutrient content to be declared Forms and solubilities of the nutrients Other criteria
1	2	3	4	5	6
1	Nitrogen fertiliser solution	Product obtained chemically and by dissolution in water, in a form stable at atmospheric pressure, without addition of organic nutrients of animal or vegetable origin	15 % N Nitrogen expressed as total nitrogen or, if there is only one form, nitric nitrogen or ammoniacal nitrogen or ureic nitrogen Maximum biuret content: ureic N × 0,026		Total nitrogen and, for any form that amounts to not less than 1 %, nitric nitrogen, ammoniacal nitrogen and/or ureic nitrogen If the biuret content is less than 0,2 %, the words 'low in biuret' may be added
2	Urea Ammonium nitrate fertiliser solution	Product obtained chemically and by dissolution in water, containing ammonium nitrate and urea	26 % N Nitrogen expressed as total nitrogen, where the ureic nitrogen accounts for about half of the nitrogen present Maximum biuret content: 0,5 %		Total nitrogen Nitric nitrogen, ammoniacal nitrogen and ureic nitrogen If the biuret content is less than 0,2 %, the words 'low in biuret' may be added
3	Calcium nitrate solution	Product obtained by dissolving calcium nitrate in water	8 % N Nitrogen expressed as nitrogen in nitric form with a maximum 1 % nitrogen as ammonia Calcium expressed as water soluble CaO	The type designation may be followed, as appropriate, by one of the following indications: — for foliar application; — for making nutrient solutions; — for ferti-irrigation.	Total nitrogen Water soluble calcium oxide for the uses stipulated in column 5 Optionally: — nitrogen in nitric form; — nitrogen as ammonia.
4	Magnesium nitrate solution	Product obtained chemically and by dissolving magnesium nitrate in water	6 % N Nitrogen expressed as nitric nitrogen 9 % MgO Magnesium expressed as water-soluble magnesium oxide Minimum pH: 4		Nitric nitrogen Water-soluble magnesium oxide

1	2	3	4	5	6
5	Calcium nitrate suspension	Product obtained by suspension of calcium nitrate in water	8 % N Nitrogen expressed as total nitrogen or nitric and ammoniacal nitrogen maximum content of ammoniacal nitrogen: 1,0 % 14 % CaO Calcium expressed as water soluble CaO	The type designation may be followed by one of the following indications: — for foliar application; — for making nutrient solutions and suspensions; — for fertigation.	Total nitrogen Nitric nitrogen Water soluble calcium oxide for the uses stipulated in column 5
6	Nitrogen fertiliser solution with urea formaldehyde	Product obtained chemically or by dissolution in water of urea formaldehyde and a nitrogenous fertiliser from list A-1 in this regulation, excluding products 3(a), 3(b), and 5	18 % N expressed as total nitrogen At least one third of the declared total nitrogen content must derive from urea formaldehyde Maximum biuret content: (ureic N + urea formaldehyde N) × 0,026		Total nitrogen For each form amounting to at least 1 %: — Nitric nitrogen; — Ammoniacal nitrogen; — Ureic nitrogen. Nitrogen from urea formaldehyde
7	Nitrogen fertiliser suspension with urea formaldehyde	Product obtained chemically or by suspension in water of urea formaldehyde and a nitrogenous fertiliser from list A-1 in this regulation, excluding products 3(a), 3(b), and 5	18 % N expressed as total nitrogen At least one third of the declared total nitrogen content must derive from urea formaldehyde of which at least three fifths has to be soluble in hot water Maximum biuret content: (ureic N + urea formaldehyde N) × 0,026		Total nitrogen For each form amounting to at least 1 %: — Nitric nitrogen; — Ammoniacal nitrogen; — Ureic nitrogen. Nitrogen from urea formaldehyde Nitrogen from urea formaldehyde that is soluble in cold water Nitrogen from urea formaldehyde that is only soluble in hot water

C.2. Compound fluid fertilisers

C.2.1.	Type designation:	NPK-fertiliser solution.
	Data on method of production:	Product obtained chemically and by dissolution in water, in a form stable at atmospheric pressure, without addition of organic nutrients of animal or vegetable origin.
	Minimum content of nutrients (percentage by weight) and other requirements:	<ul style="list-style-type: none"> — Total: 15 %, (N + P₂O₅ + K₂O); — For each of the nutrients: 2 % N, 3 % P₂O₅, 3 % K₂O; — Maximum biuret content: ureic N × 0,026.

Forms, solubilities and nutrient content to be declared as specified in columns 4, 5 and 6 Particle size			Data for identification of the fertilisers Other requirements		
N	P ₂ O ₅	K ₂ O	N	P ₂ O ₅	K ₂ O
1	2	3	4	5	6
(1) Total nitrogen (2) Nitric nitrogen (3) Ammoniacal nitrogen (4) Ureic nitrogen	Water-soluble P ₂ O ₅	Water-soluble K ₂ O	(1) Total nitrogen (2) If any of the forms of nitrogen (2) to (4) amounts to not less than 1 % by weight, it must be declared (3) If the biuret content is less than 0,2 %, the words 'low in biuret' may be added	Water-soluble P ₂ O ₅	(1) Water-soluble potassium oxide (2) The words 'low in chloride' may be used only where the Cl content does not exceed 2 % (3) The chloride content may be declared

C.2. Compound fluid fertilisers (cont'd)

C.2.2.	Type designation:	NPK-fertiliser suspension.
	Data on method of production:	Product in liquid form, in which the nutrients are derived from substances both in suspension in the water and in solution without addition of organic nutrients of animal or vegetable origin.
	Minimum content of nutrients (percentage by weight) and other requirements:	<ul style="list-style-type: none"> — Total: 20 %, (N + P₂O₅ + K₂O); — For each of the nutrients: 3 % N, 4 % P₂O₅, 4 % K₂O; — Maximum biuret content: ureic N × 0,026.

Forms, solubilities and nutrient content to be declared as specified in columns 4, 5 and 6 Particle size			Data for identification of the fertilisers Other requirements		
N	P ₂ O ₅	K ₂ O	N	P ₂ O ₅	K ₂ O
1	2	3	4	5	6
(1) Total nitrogen (2) Nitric nitrogen (3) Ammoniacal nitrogen (4) Ureic nitrogen	(1) Water-soluble P ₂ O ₅ (2) P ₂ O ₅ soluble in neutral ammonium citrate (3) P ₂ O ₅ soluble in neutral ammonium citrate and water	Water-soluble K ₂ O	(1) Total nitrogen (2) If any of the forms of nitrogen 2 to 4 amounts to not less than 1 % by weight, it must be declared (3) If the biuret content is less than 0,2 %, the words 'low in biuret' may be added	The fertilisers must not contain Thomas slag, aluminium calcium phosphate, calcined phosphates, partially solubilised phosphates or rock phosphates (1) If the water-soluble P ₂ O ₅ is less than 2 %, only solubility 2 shall be declared (2) If the water-soluble P ₂ O ₅ is at least 2 %, solubility 3 and the water-soluble P ₂ O ₅ content shall be declared	(1) Water-soluble potassium oxide (2) The words 'low in chloride' may be used only where the Cl content does not exceed 2 % (3) The chloride content may be declared

C.2. Compound fluid fertilisers (cont'd)

C.2.3.	Type designation:	NP-fertiliser solution.
	Data on method of production:	Product obtained chemically and by dissolution in water, in a form stable at atmospheric pressure, without addition of organic nutrients of animal or vegetable origin.
	Minimum content of nutrients (percentage by weight):	— Total: 18 %, (N + P ₂ O ₅); — For each of the nutrients: 3 % N, 5 % P ₂ O ₅ ; — Maximum biuret content: ureic N × 0,026.

Forms, solubilities and nutrient content to be declared as specified in columns 4, 5 and 6 Particle size			Data for identification of the fertilisers Other requirements		
N	P ₂ O ₅	K ₂ O	N	P ₂ O ₅	K ₂ O
1	2	3	4	5	6
(1) Total nitrogen (2) Nitric nitrogen (3) Ammoniacal nitrogen (4) Ureic nitrogen	P ₂ O ₅ Water-soluble		(1) Total nitrogen (2) If any of the forms of nitrogen (2) to (4) amounts to not less than 1 % by weight, it must be declared.	Water-soluble P ₂ O ₅	

1	2	3	4	5	6
			(3) If the biuret content is less than 0,2 %, the words 'low in biuret' may be added		

C.2. Compound fluid fertilisers (cont'd)

C.2.4.	Type designation:	NP-fertiliser suspension.
	Data on method of production:	Product in liquid form, in which the nutrients are derived from substances both in solution and in suspension in the water, without addition of organic nutrients of animal or vegetable origin.
	Minimum content of nutrients (percentage by weight):	<ul style="list-style-type: none"> — Total: 18 %, (N + P₂O₅); — For each of the nutrients: 3 % N, 5 % P₂O₅; — Maximum biuret content: ureic N × 0,026.

Forms, solubilities and nutrient content to be declared as specified in columns 4, 5 and 6 Particle size			Data for identification of the fertilisers Other requirements		
N	P ₂ O ₅	K ₂ O	N	P ₂ O ₅	K ₂ O
1	2	3	4	5	6
(1) Total nitrogen	(1) Water-soluble P ₂ O ₅		(1) Total nitrogen	(1) If the water-soluble P ₂ O ₅ is less than 2 % only solubility 2 shall be declared	
(2) Nitric nitrogen	(2) P ₂ O ₅ soluble in neutral ammonium citrate		(2) If any of the forms of nitrogen (2) to (4) amounts to not less than 1 % by weight, it must be declared.	(2) If the water-soluble P ₂ O ₅ is at least 2 %, solubility 3 will be declared and the water-soluble P ₂ O ₅ content must be stated.	
(3) Ammoniacal nitrogen	(3) P ₂ O ₅ soluble in neutral ammonium citrate and water		(3) If the biuret content is less than 0,2 %, the words 'low in biuret' may be added	The fertilisers may not contain Thomas slag, aluminium calcium phosphate, calcined phosphates, partially solubilised phosphate or rock phosphates	
(4) Ureic nitrogen					

C.2. Compound fluid fertilisers (cont'd)

C.2.5.	Type designation:	NK-fertiliser solution.
	Data on method of production:	Product obtained chemically and by dissolution in water, in a form stable at atmospheric pressure, without addition of organic nutrients of animal or vegetable origin.
	Minimum content of nutrients (percentage by weight):	<ul style="list-style-type: none"> — Total: 15 % (N + K₂O); — For each of the nutrients: 3 % N, 5 % K₂O; — Maximum biuret content: ureic N × 0,026.

Forms, solubilities and nutrient content to be declared as specified in columns 4, 5 and 6 Particle size			Data for identification of the fertilisers Other requirements		
N	P ₂ O ₅	K ₂ O	N	P ₂ O ₅	K ₂ O
1	2	3	4	5	6
(1) Total nitrogen (2) Nitric nitrogen (3) Ammoniacal nitrogen (4) Ureic nitrogen		Water-soluble K ₂ O	(1) Total nitrogen (2) If any of the forms of nitrogen (2) to (4) amounts to not less than 1 % by weight, it must be declared (3) If the biuret content is less than 0,2 %, the words 'low in biuret' may be added		(1) Water-soluble potassium oxide (2) The words 'low in chloride' may be used only where the Cl content does not exceed 2% (3) The chloride content may be declared

C.2. Compound fluid fertilisers (cont'd)

C.2.6.	Type designation:	NK-fertiliser suspension.
	Data on method of production:	Product in liquid form, in which the nutrients are derived from substances both in solution and in suspension in the water, without addition of organic nutrients of animal or vegetable origin.
	Minimum content of nutrients (percentage by weight):	<ul style="list-style-type: none"> — Total: 18 % (N + K₂O); — For each of the nutrients: 3 % N, 5 % K₂O; — Maximum biuret content: ureic N × 0,026.

Forms, solubilities and nutrient content to be declared as specified in columns 4, 5 and 6 Particle size			Data for identification of the fertilisers Other requirements		
N	P ₂ O ₅	K ₂ O	N	P ₂ O ₅	K ₂ O
1	2	3	4	5	6
(1) Total nitrogen (2) Nitric nitrogen (3) Ammoniacal nitrogen (4) Ureic nitrogen		Water-soluble K ₂ O	(1) Total nitrogen (2) If any of the forms of nitrogen (2) to (4) amounts to not less than 1 % by weight, it must be declared (3) If the biuret content is less than 0,2 %, the words 'low in biuret' may be added		(1) Water-soluble potassium oxide (2) The words 'low in chloride' may be used only where the Cl content does not exceed 2% (3) The chloride content may be declared

C.2. Compound fluid fertilisers (cont'd)

C.2.7.	Type designation:	PK-fertiliser solution.
	Data on method of production:	Product obtained chemically and by dissolution in water, without addition of organic nutrients of animal or vegetable origin.
	Minimum content of nutrients (percentage by weight):	— Total: 18 % (P ₂ O ₅ + K ₂ O); — For each of the nutrients: 5 % P ₂ O ₅ , 5 % K ₂ O.

Forms, solubilities and nutrient content to be declared as specified in columns 4, 5 and 6 Particle size			Data for identification of the fertilisers Other requirements		
N	P ₂ O ₅	K ₂ O	N	P ₂ O ₅	K ₂ O
1	2	3	4	5	6
	Water-soluble P ₂ O ₅	Water-soluble K ₂ O		Water-soluble P ₂ O ₅	(1) Water-soluble potassium oxide (2) The words 'low in chloride' may be used only where the Cl content does not exceed 2% (3) The chloride content may be declared

C.2. Compound fluid fertilisers (cont'd)

C.2.8.	Type designation:	PK-fertiliser suspension.
	Data on method of production:	Product in liquid form, in which the nutrients are derived from substances both in solution and in suspension in water, without addition of organic nutrients of animal or vegetable origin.
	Minimum content of nutrients (percentage by weight):	— Total: 18 % (P ₂ O ₅ + K ₂ O); — For each of the nutrients: 5 % P ₂ O ₅ , 5 % K ₂ O.

Forms, solubilities and nutrient content to be declared as specified in columns 4, 5 and 6 Particle size			Data for identification of the fertilisers Other requirements		
N	P ₂ O ₅	K ₂ O	N	P ₂ O ₅	K ₂ O
1	2	3	4	5	6
	(1) Water-soluble P ₂ O ₅ (2) P ₂ O ₅ soluble in neutral ammonium citrate (3) P ₂ O ₅ soluble in neutral ammonium citrate and water	Water-soluble K ₂ O		(1) If the water-soluble P ₂ O ₅ is less than 2 % only solubility 2 will be declared (2) If the water-soluble P ₂ O ₅ is at least 2 % solubility 3 and the water-soluble P ₂ O ₅ content shall be declared The fertilisers must not contain Thomas slag, aluminium calcium phosphate, calcined phosphates, partially solubilised phosphates or rock phosphates	(1) Water-soluble potassium oxide (2) The words 'low in chloride' may be used only where the Cl content does not exceed 2% (3) The chloride content may be declared

D. Inorganic secondary nutrient fertilisers

No	Type designation	Data on method of production and essential ingredients	Minimum content of nutrients (percentage by weight) Data on the expression of nutrients Other requirements	Other data or type designation	Nutrient content to be declared Forms and solubilities of the nutrients Other criteria
1	2	3	4	5	6
1	Calcium sulphate	Product of natural or industrial origin containing calcium sulphate at various degrees of hydration	25 % CaO 35 % SO ₃ Calcium and sulphur expressed as total CaO + SO ₃ Fineness of grind: — at least 80 % to pass through a sieve with a 2 mm mesh width, — at least 99 % to pass through a sieve with a 10 mm mesh width	Usual trade names may be added	Total sulphur trioxide Optional: total CaO
2	Calcium chloride solution	Calcium chloride solution of industrial origin	12 % CaO Calcium expressed as water-soluble CaO		Calcium oxide Optional: for plant spraying
3	Elemental sulphur	Comparatively refined natural or industrial product	98 % S (245 %: SO ₃) Sulphur expressed as total SO ₃		Total sulphur trioxide
4	Kieserite	Product of mineral origin containing monohydrated magnesium sulphate as main component	24 % MgO 45 % SO ₃ Magnesium and sulphur expressed as water-soluble magnesium oxide and sulphur trioxide	Usual trade names may be added	Water-soluble magnesium oxide Optional: water-soluble sulphur trioxide
5	Magnesium sulphate	Product containing heptahydrated magnesium sulphate as main component	15 % MgO 28 % SO ₃ Magnesium and sulphur expressed as water-soluble magnesium oxide and sulphur trioxide	Usual trade names may be added	Water-soluble magnesium oxide Optional: water-soluble sulphur trioxide
5.1	Magnesium sulphate solution	Product obtained by dissolution in water of magnesium sulphate of industrial origin	5 % MgO 10 % SO ₃ Magnesium and sulphur expressed as water-soluble magnesium oxide and water-soluble sulphuric anhydride	Usual trade names may be added	Water-soluble magnesium oxide Optional: water-soluble sulphuric anhydride
5.2	Magnesium hydroxide	Product obtained chemically and having as its essential ingredient magnesium hydroxide	60 % MgO Particle size: at least 99 % able to pass through a sieve with a mesh of 0,063 mm		Total magnesium oxide

1	2	3	4	5	6
5.3	Suspension of magnesium hydroxide	Product obtained by suspension of type 5.2	24 % MgO		Total magnesium oxide
6	Magnesium chloride solution	Product obtained by dissolving magnesium chloride of industrial origin	13 % MgO Magnesium expressed as magnesium oxide Maximum calcium content: 3 % CaO		Magnesium oxide

E. Inorganic micro-nutrient fertilisers

Explanatory note: The following notes are applicable to the whole of Part E.

Note 1: A chelating agent may be designated by means of its initials as set out in E.3.

Note 2: If the product leaves no solid residue after being dissolved in water it may be described as 'for dissolution'.

Note 3: Where a micro-nutrient is present in a chelated form, the pH range guaranteeing acceptable stability of the chelated fraction shall be stated.

E.1. Fertilisers containing only one micro-nutrient

E.1.1. Boron

No	Type designation	Data on method of production and essential ingredients	Minimum content of nutrients (percentage by weight) Data on the expression of nutrients Other requirements	Other data on the type of designation	Nutrient content to be declared Forms and solubilities of the nutrients Other criteria
1	2	3	4	5	6
1a	Boric acid	Product obtained by the action of an acid on a borate	14 % water-soluble B	The usual trade names may be added	Water-soluble boron (B)
1b	Sodium borate	Chemically obtained product containing as its essential component a sodium borate	10 % water-soluble B	The usual trade names may be added	Water-soluble boron (B)
1c	Calcium borate	Product obtained from colemanite or pandermite containing as its essential ingredient calcium borates	7 % total B Particle size: at least 98 % passing through a 0,063 mm sieve	The usual trade names may be added	Total boron (B)
1d	Boron ethanol amine	Product obtained by reacting a boric acid with an ethanol amine	8 % water-soluble B		Water-soluble boron (B)

1	2	3	4	5	6
1e	Borated fertiliser in solution	Product obtained by dissolving types 1a and/or 1b and/or 1d	2 % water-soluble B	The designation must include the names of the constituents present	Water-soluble boron (B)
1f	Borated fertiliser in suspension	Product obtained by suspending types 1a and/or 1b and/or 1d in water	2 % water-soluble B	The designation must include the names of the constituents present	Water-soluble boron (B)

E.1.2. Cobalt

No	Type designation	Data on method of production and essential ingredients	Minimum content of nutrients (percentage by weight) Data on the expression of nutrients Other requirements	Other data on the type of designation	Nutrient content to be declared Forms and solubilities of the nutrients Other criteria
1	2	3	4	5	6
2a	Cobalt salt	Chemically obtained product containing a mineral salt of cobalt as its essential ingredient	19 % water-soluble Co	The designation must include the name of the mineral anion	Water-soluble cobalt (Co)
2b	Cobalt chelate	Water-soluble product obtained by combining cobalt chemically with a chelating agent	2 % water-soluble Co, at least 8/10 of the declared value of which has been chelated	Name of the chelating agent	Water-soluble cobalt (Co) Chelated cobalt (Co)
2c	Cobalt fertiliser solution	Product obtained by dissolving types 2a and/or one of the type 2b in water	2 % water-soluble Co	The designation must include: (1) the name(s) of the mineral anion(s); (2) the name of any chelating agent if present	Water-soluble cobalt (Co) Chelated cobalt (Co) if present

E.1.3. Copper

No	Type designation	Data on method of production and essential ingredients	Minimum content of nutrients (percentage by weight) Data on the expression of nutrients Other requirements	Other data on the type of designation	Nutrient content to be declared Forms and solubilities of the nutrients Other criteria
1	2	3	4	5	6
3a	Copper salt	Chemically obtained product containing a mineral salt of copper as its essential ingredient	20 % water-soluble Cu	The designation must include the name of the mineral anion	Water-soluble copper (Cu)
3b	Copper oxide	Chemically obtained product containing copper oxide as its essential ingredient	70 % total Cu Particle size: at least 98 % passing through a 0,063 mm sieve		Total copper (Cu)
3c	Copper hydroxide	Chemically obtained product containing copper hydroxide as its essential ingredient	45 % total Cu Particle size: at least 98 % passing through a 0,063 mm sieve		Total copper (Cu)
3d	Copper chelate	Water-soluble product obtained by combining copper chemically with a chelating agent	9 % water-soluble Cu, at least 8/10 of the declared value of which has been chelated	Name of the chelating agent	Water-soluble copper (Cu) Chelated copper (Cu)
3e	Copper-based fertiliser	Product obtained by mixing types 3a and/or 3b and/or 3c and/or a single one of type 3d and, if required, filler that is neither nutrient nor toxic	5 % total Cu	The designation must include: (1) the name(s) of the copper components; (2) the name of any chelating agent if present	Total copper (Cu) Water-soluble copper (Cu) if this accounts for at least 1/4 of the total copper Chelated copper (Cu) if present
3f	Copper fertiliser solution	Product obtained by dissolving types 3a and/or one of the type 3d in water	3 % water-soluble Cu	The designation must include: (1) the name(s) of the mineral anion(s); (2) the name of any chelating agent if present	Water-soluble copper (Cu) Chelated copper (Cu) if present
3g	Copper oxychloride	Chemically obtained product containing copper oxychloride [Cu ₂ Cl(OH) ₃] as an essential ingredient	50 % total Cu Particle size: at least 98 % passing through a 0,063 mm sieve		Total copper (Cu)
3h	Copper oxychloride suspension	Product obtained by suspension of type 3 g	17 % total Cu		Total copper (Cu)

E.1.4. Iron

No	Type designation	Data on method of production and essential ingredients	Minimum content of nutrients (percentage by weight) Data on the expression of nutrients Other requirements	Other data on the type of designation	Nutrient content to be declared Forms and solubilities of the nutrients Other criteria
1	2	3	4	5	6
4a	Iron salt	Chemically obtained product containing a mineral iron salt as its essential ingredient	12 % water-soluble Fe	The designation must include the name of the mineral anion	Water-soluble iron (Fe)
4b	Iron chelate	Water soluble product obtained by chemical reaction of iron with chelating agents mentioned in the list of Annex I chapter E.3	5 % of water soluble iron, of which the chelated fraction is at least 80 %	Name of the chelating agents	<ul style="list-style-type: none"> — Iron (Fe) water soluble — Chelated fraction (EN 13366) — Iron (Fe) chelated by each chelating agent insofar as each fraction exceeds 2 % (EN 13368 part 1 and 2)
4c	Iron fertiliser solution	Product obtained by dissolving types 4a and/or one of the type 4b in water	2 % water-soluble Fe	The designation must include: (1) the name(s) of the mineral anion(s); (2) the name of any chelating agent if present	Water-soluble iron (Fe) Chelated iron (Fe) if present

E.1.5. Manganese

No	Type designation	Data on method of production and essential ingredients	Minimum content of nutrients (percentage by weight) Data on the expression of nutrients Other requirements	Other data on the type of designation	Nutrient content to be declared Forms and solubilities of the nutrients Other criteria
1	2	3	4	5	6
5a	Manganese salt	Chemically obtained product containing a mineral manganese salt (Mn II) as its essential ingredient	17 % water-soluble Mn	The designation must include the name of the combined anion	Water-soluble manganese (Mn)
5b	Manganese chelate	Water-soluble product obtained by combining manganese chemically with a chelating agent	5 % water-soluble Mn, at least 8/10 of the declared value of which has been chelated	Name of the chelating agent	Water-soluble manganese (Mn) Chelated manganese (Mn)
5c	Manganese oxide	Chemically obtained product containing manganese oxides as essential ingredients	40 % total Mn Particle size: at least 80 % passing through a 0,063 mm sieve		Total manganese (Mn)

1	2	3	4	5	6
5d	Manganese-based fertiliser	Product obtained by mixing types 5a and 5c	17 % total Mn	The designation must include the name of the manganese components	Total manganese (Mn) Water-soluble manganese (Mn) if this accounts for at least 1/4 of the total manganese
5e	Manganese-based fertiliser solution	Product obtained by dissolving types 5a and/or one of the type 5b in water	3 % water-soluble Mn	The designation must include: (1) the name(s) of the mineral anion(s); (2) the name of any chelating agent if present	Water-soluble manganese (Mn) Chelated manganese (Mn) if present

E.1.6. Molybdenum

No	Type designation	Data on method of production and essential ingredients	Minimum content of nutrients (percentage by weight) Data on the expression of nutrients Other requirements	Other data on the type of designation	Nutrient content to be declared Forms and solubilities of the nutrients Other criteria
1	2	3	4	5	6
6a	Sodium molybdate	Chemically obtained product containing sodium molybdate as its essential ingredient	35 % water-soluble Mo		Water-soluble molybdenum (Mo)
6b	Ammonium molybdate	Chemically obtained product containing ammonium molybdate as its essential ingredient	50 % water-soluble Mo		Water-soluble molybdenum (Mo)
6c	Molybdenum-based fertiliser	Product obtained by mixing types 6a and 6b	35 % water-soluble Mo	The designation must include the names of the molybdenum components	Water-soluble molybdenum (Mo)
6d	Molybdenum-based fertiliser solution	Product obtained by dissolving types 6a and/or one of the type 6b in water	3 % water-soluble Mo	The designation must include the name(s) of the molybdenum component(s)	Water-soluble molybdenum (Mo)

E.1.7. Zinc

No	Type designation	Data on method of production and essential ingredients	Minimum content of nutrients (percentage by weight) Data on the expression of nutrients Other requirements	Other data on the type of designation	Nutrient content to be declared Forms and solubilities of the nutrients Other criteria
1	2	3	4	5	6
7a	Zinc salt	Chemically obtained product and having as its essential ingredient a mineral salt of zinc	15 % water-soluble Zn	The designation must include the name of the mineral anion	Water-soluble zinc (Zn)
7b	Zinc chelate	Water-soluble product obtained by combining zinc chemically with a chelating agent	5 % water-soluble Zn, at least 8/10 of the declared content of which has been chelated	Name of the chelating agent	Water-soluble zinc (Zn) Chelated zinc (Zn)
7c	Zinc oxide	Chemically obtained product and having as its essential ingredient zinc oxide	70 % total Zn Particle size: at least 80 % passing through a 0,063 mm sieve		Total zinc (Zn)
7d	Zinc-based fertiliser	Product obtained by mixing types 7a and 7c	30 % total Zn	The designation must include the name of the zinc components present	Total zinc (Zn) Water-soluble zinc (Zn) if this accounts for at least 1/4 of the total zinc (Zn)
7e	Zinc-based fertiliser solution	Product obtained by dissolving types 7a and/or one of type 7b in water	3 % water-soluble Zn	The designation must include: (1) the name(s) of the mineral anion(s); (2) the name of any chelating agent if present.	Water-soluble zinc (Zn) Chelated zinc (Zn) if present

E.2. Minimum micro-nutrient content, percentage weight of fertilisers

E.2.1. Solid or fluid mixtures of micro-nutrient

	Where the micro-nutrient is present in a form that is	
	exclusively mineral	chelated or complexed
For a micro-nutrient:		
Boron (B)	0,2	0,2
Cobalt (Co)	0,02	0,02
Copper (Cu)	0,5	0,1
Iron (Fe)	2,0	0,3
Manganese (Mn)	0,5	0,1
Molybdenum (Mo)	0,02	—
Zinc (Zn)	0,5	0,1

Minimum total of micro-nutrient in a solid mixture: 5 % by mass of the fertiliser.

Minimum total of micro-nutrient in a fluid mixture: 2 % by mass of the fertiliser.

E.2.2. EC fertilisers containing primary and/or secondary nutrient with micro-nutrient applied to the soil

	For crops or grassland	For horticultural use
Boron (B)	0,01	0,01
Cobalt (Co)	0,002	—
Copper (Cu)	0,01	0,002
Iron (Fe)	0,5	0,02
Manganese (Mn)	0,1	0,01
Molybdenum (Mo)	0,001	0,001
Zinc (Zn)	0,01	0,002

E.2.3. EC fertilisers containing primary and/or secondary nutrient with micro-nutrients for leaf sprays

Boron (B)	0,010
Cobalt (Co)	0,002
Copper (Cu)	0,002
Iron (Fe)	0,020
Manganese (Mn)	0,010
Molybdenum (Mo)	0,001
Zinc (Zn)	0,002

E.3. List of authorised organic chelating and complexing agents for micro-nutrients

The following products are authorised provided they have complied with the requirements of Directive 67/548/EEC ⁽¹⁾ as amended.

E.3.1. Chelating agents ⁽²⁾

Sodium, potassium or ammonium acid or salts of:

ethylenediaminetetraacetic acid	EDTA	C ₁₀ H ₁₆ O ₈ N ₂
diethylenetriaminepentaacetic acid	DTPA	C ₁₄ H ₂₃ O ₁₀ N ₃
[o,o]: ethylenediamine-di (o-hydroxyphenyl acetic) acid	EDDHA	C ₁₈ H ₂₀ O ₆ N ₂
[o,p]: ethylenediamine-N-(o-hydroxyphenylacetic acid)-N'-(p-hydroxyphenylacetic) acid	EDDHA	C ₁₈ H ₂₀ O ₆ N ₂
2-hydroxyethylethylenediaminetriacetic acid	HEEDTA	C ₁₀ H ₁₈ O ₇ N ₂
[o,o]: ethylenediamine-di (o-hydroxy-o-methylphenylacetic) acid	EDDHMA	C ₂₀ H ₂₄ O ₆ N ₂
[o,p]: ethylenediamine-di (o-hydroxy-p-methylphenylacetic) acid	EDDHMA	C ₂₀ H ₂₄ O ₆ N ₂
[p,o]: ethylenediamine-di (p-hydroxy-o-methylphenylacetic) acid	EDDHMA	C ₂₀ H ₂₄ O ₆ N ₂
[2,4]: ethylenediamine di-(2-hydroxy-4-carboxyphenylacetic) acid	EDDCHA	C ₂₀ H ₂₀ O ₁₀ N ₂
[2,5]: ethylenediamine di-(2-carboxy-5-hydroxyphenylacetic) acid	EDDCHA	C ₂₀ H ₂₀ O ₁₀ N ₂
[5,2]: ethylenediamine di-(5-carboxy-2-hydroxyphenylacetic) acid	EDDCHA	C ₂₀ H ₂₀ O ₁₀ N ₂

E.3.2. Complexing agents:

List to be drawn up.

⁽¹⁾ OJ L 196, 16.8.1967, p. 1.

⁽²⁾ The chelating agents are to be identified and quantified by European Standard EN 13368 part 1 and part 2, to the extent that this standard covers the above agents.

ANNEX II

TOLERANCES

The tolerances given in this Annex are negative values in percentage by mass.

The tolerance allowed in respect of the declared nutrient contents in the various types of EC fertiliser are as follows:

1. **Inorganic straight primary nutrient fertilisers absolute value in percentage by mass expressed as N, P₂O₅, K₂O, MgO, Cl**

1.1. *Nitrogenous fertilisers*

calcium nitrate	0,4
calcium — magnesium nitrate	0,4
sodium nitrate	0,4
chile nitrate	0,4
calcium cyanamide	1,0
nitrogenous calcium cyanamide	1,0
ammonium sulphate	0,3
Ammonium nitrate or calcium ammonium nitrate:	
— up to and including 32 %	0,8
— more than 32 %	0,6
ammonium sulphate-nitrate	0,8
magnesium sulphonitrate	0,8
magnesium ammonium nitrate	0,8
urea	0,4
calcium nitrate suspension	0,4
nitrogen fertiliser solution with urea formaldehyde	0,4
nitrogen fertiliser suspension with urea formaldehyde	0,4
urea-ammonium sulphate	0,5
nitrogen fertiliser solution	0,6
ammonium nitrate-urea solution	0,6

1.2. *Phosphatic fertilisers*

Thomas slag:

— declaration expressed as a range of 2 % by mass	0,0
— declaration expressed as a single number	1,0

Other phosphatic fertilisers

P ₂ O ₅ solubility in:	(number of fertiliser in Annex I)	
— mineral acid	(3, 6, 7)	0,8
— formic acid	(7)	0,8
— neutral ammonium citrate	(2a, 2b, 2c)	0,8
— alkaline ammonium citrate	(4, 5, 6)	0,8
— water	(2a, 2b, 3)	0,9
	(2c)	1,3

1.3. *Potassic fertilisers*

kainit	1,5
enriched kainit salt	1,0
muriate of potash:	
— up to and including 55 %	1,0
— more than 55 %	0,5
potassium chloride containing magnesium salt	1,5
sulphate of potash	0,5
sulphate of potash containing magnesium salt	1,5

1.4. *Other components*

chloride	0,2
----------	-----

2. **Inorganic compound primary nutrient fertilisers**2.1. *Nutrient elements*

N	1,1
P ₂ O ₅	1,1
K ₂ O	1,1

2.2. *Total negative deviations from the declared value*

binary fertilisers	1,5
ternary fertilisers	1,9

3. **Secondary nutrients in fertilisers**

The tolerances allowed in respect of the declared calcium, magnesium, sodium and sulphur contents shall be a quarter of the declared contents of these nutrients up to a maximum of 0,9 % in absolute terms for CaO, MgO, Na₂O, and SO₃, i.e. 0,64 for Ca, 0,55 for Mg, 0,67 for Na and 0,36 for S.

4. **Micro-nutrients in fertilisers**

The tolerance allowed in respect of the declared micro-nutrient content shall be:

- 0,4 % in absolute terms for a content of more than 2 %,
- one fifth of the declared value for a content not exceeding 2 %.

The tolerance allowed in respect of the declared content for the various forms of nitrogen or the declared solubilities of phosphorus pentoxide is one-tenth of the overall content of the nutrient concerned with a maximum of 2 % by mass, provided that the overall content of that nutrient remains within the limits specified in Annex I and the tolerances specified above.

ANNEX III

TECHNICAL PROVISIONS FOR AMMONIUM NITRATE FERTILISERS OF HIGH NITROGEN CONTENT**1. Characteristics of and limits for straight ammonium nitrate fertilisers of high nitrogen content****1.1. Porosity (oil retention)**

The oil retention of the fertiliser, which must first have undergone two thermal cycles of a temperature ranging from 25 to 50 °C and conforming with the provisions of part 2 of section 3. of this Annex, must not exceed 4 % by mass.

1.2. Combustible ingredients

The percentage by mass of combustible material measured as carbon must not exceed 0,2 % for fertilisers having a nitrogen content of at least 31,5 % by mass and must not exceed 0,4 % for fertilisers having a nitrogen content of at least 28 % but less than 31,5 % by mass.

1.3. pH

A solution of 10 g of fertiliser in 100 ml of water must have a pH of at least 4.5.

1.4. Particle size analysis

Not more than 5 % by mass of the fertiliser must pass through a 1 mm mesh sieve and not more than 3 % by mass must pass through a 0,5 mm mesh sieve.

1.5. Chlorine

The maximum chlorine content is set at 0,02 % by mass.

1.6. Heavy metals

Heavy metals should not be added deliberately, and any traces which are incidental to the production process should not exceed the limit fixed by the Committee.

The copper content shall not be higher than 10 mg/kg.

No limits are specified for other heavy metals.

2. Description of the test of resistance to detonation concerning ammonium nitrate fertilisers of high nitrogen content

The test must be carried out on a representative sample of fertiliser. Before being tested for resistance to detonation, the whole mass of the sample is to be thermally cycled five times complying with the provisions of part 3 in section 3. of this Annex.

The fertiliser must be subjected to the test of resistance to detonation in a horizontal steel tube under the following conditions:

- seamless steel tube,
- Tube length: 1 000 mm at least,
- Nominal external diameter: 114 mm at least,
- Nominal wall thickness: 5 mm at least,
- Booster: the type and mass of the booster chosen should be such as to maximise the detonation pressure applied to the sample in order to determine its susceptibility to the transmission of detonation,
- Test temperature: 15-25 °C,
- Witness lead cylinders for detecting detonation: 50 mm diameter and 100 mm high

- placed at 150 mm intervals and supporting the tube horizontally. The test is to be carried out twice. The test is deemed conclusive if in both tests one or more of the supporting lead cylinders is crushed by less than 5 %.

3. Methods of checking compliance with the limits specified in Annexes III-1 and III-2

Method 1

Methods for the application of thermal cycles

1. Scope and field of application

This document defines the procedures for the application of thermal cycles prior to the execution of the oil retention test for straight ammonium nitrate fertilisers of high nitrogen content and of the test on the resistance to detonation for both, straight and compound ammonium nitrate fertiliser of high nitrogen content.

The methods of the closed thermal cycles as described in this section are regarded as simulating sufficiently the conditions to be taken into account within the scope of application of title II, chapter IV, however, these methods may not necessarily simulate all conditions arising during transport and storage;

2. Thermal cycles referred to in Annex III-1

2.1. Field of application

This procedure is for thermal cycling prior to determining the oil retention of the fertiliser.

2.2. Principle and definition

In an Erlenmeyer flask, heat the sample from ambient temperature to 50 °C and maintain at this temperature for a period of two hours (phase at 50 °C). Thereupon cool the sample until a temperature of 25 °C is achieved and maintain at that temperature for two hours (phase at 25 °C). The combination of the successive phases at 50 °C and 25 °C forms one thermal cycle. After being subjected to two thermal cycles, the test sample is held at a temperature of 20 ± 3 °C for the determination of the oil retention value.

2.3. Apparatus

Normal laboratory apparatus, in particular:

- water baths thermostated at $25 (\pm 1)$ and $50 (\pm 1)$ °C respectively,
- Erlenmeyer flasks with an individual capacity of 150 ml.

2.4. Procedure

Put each test sample of $70 (\pm 5)$ grams into an Erlenmeyer flask which is then sealed with a stopper.

Move each flask every two hours from the 50 °C bath to the 25 °C bath and vice versa.

Maintain the water in each bath at constant temperature and keep in motion by rapid stirring to ensure the water level comes above the level of the sample. Protect the stopper from condensation by a foam rubber cap.

3. Thermal cycles to be used for Annex III-2

3.1. Field of application

This procedure is for thermal cycling prior to the execution of the detonability test.

3.2. Principle and definition

In a watertight box heat the sample from ambient temperature to 50 °C and maintain at this temperature for a period of one hour (phase at 50 °C). Thereupon cool the sample until a temperature of 25 °C is achieved and maintain at that temperature for one hour (phase at 25 °C). The combination of the successive phases at 50 °C and 25 °C forms one thermal cycle. After being subjected to the required number of thermal cycles, the test sample is held at a temperature of 20 ± 3 °C pending the execution of the detonability test.

3.3. Apparatus

- A water bath, thermostated in a temperature range of 20 to 51 °C with a minimum heating and cooling rate of 10 °C/h, or two water baths, one thermostated at a temperature of 20 °C, the other at 51 °C. The water in the bath(s) is continuously stirred; the volume of the bath should be large enough to guarantee ample circulation of the water.
- A stainless steel box, watertight all around and provided with a thermocouple in the centre. The outside width of the box is 45 (± 2) mm and the wall thickness is 1,5 mm (see Figure 1). The height and length of the box can be chosen to suit the dimensions of the water bath, e.g. length 600 mm, height 400 mm.

3.4. Procedure

Place a quantity of fertilisers sufficient for a single detonation into the box and close the cover. Place the box in the water bath. Heat the water to 51 °C and measure the temperature in the centre of the fertiliser. One hour after the temperature at the centre has reached 50 °C cool the water. One hour after the temperature at the centre has reached 25 °C heat the water to start the second cycle. In the case of two water baths, transfer the box to the other bath after each heating/cooling period.

Figure 1

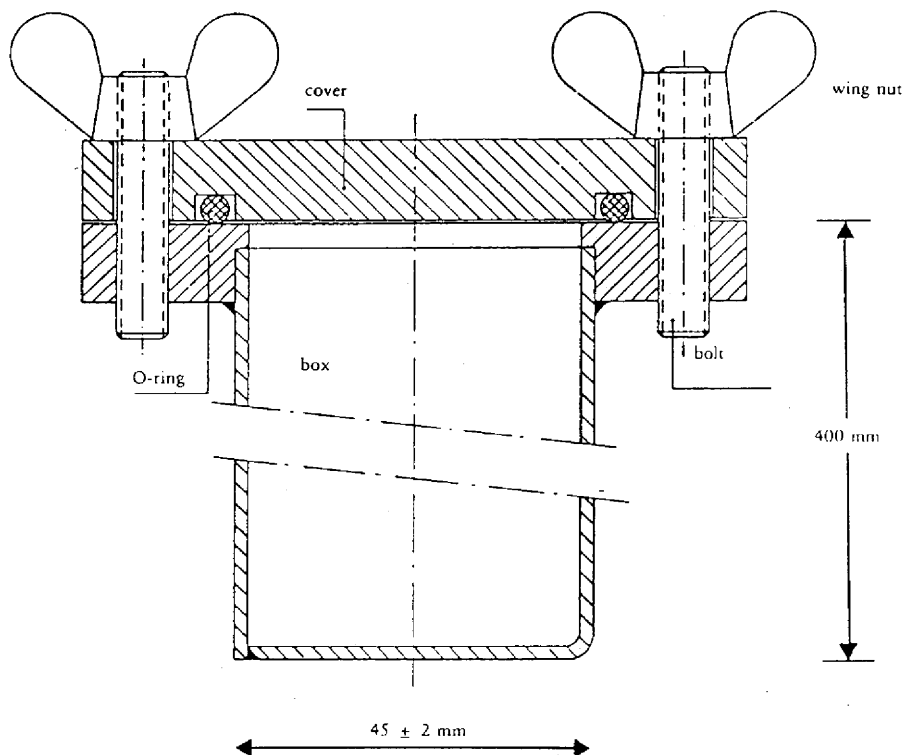

Method 2

Determination of oil retention

1. Scope and field of application

This document defines the procedure for the determination of oil retention of straight ammonium nitrate fertilisers of high nitrogen content.

The method is applicable to both prilled and granular fertilisers which do not contain oil-soluble materials.

2. Definition

Oil retention of a fertiliser: the quantity of oil retained by the fertiliser determined under the operating conditions specified, and expressed as a percentage by mass.

3. Principle

Total immersion of the test portion in gas oil for a specified period, followed by the draining away of surplus oil under specified conditions. Measurement of the increase in mass of the test portion.

4. Reagent

Gas oil

Viscosity max.: 5 mPas at 40 °C

Density: 0,8 to 0,85 g/ml at 20 °C

Sulphur content: ≤ 1,0 % (m/m)

Ash: ≤ 0,1 % (m/m)

5. Apparatus

Ordinary laboratory apparatus, and:

- 5.1. Balance, capable of weighing to the nearest 0,01 gram.
- 5.2. Beakers, of capacity 500 ml.
- 5.3. Funnel, of plastic materials, preferably with a cylindrical wall at the upper end, diameter approximately 200 mm.
- 5.4. Test sieve, aperture 0,5 mm, fitting into the funnel (5.3).

Note: The size of the funnel and sieve is such as to ensure that only a few granules lie one above another and the oil is able to drain easily.

- 5.5. Filter paper, rapid filtering grade, creped, soft, mass 150 g/m².
- 5.6. Absorbent tissue (laboratory grade).

6. Procedure

- 6.1. Two individual determinations are carried out in quick succession on separate portions of the same test sample.
- 6.2. Remove particles smaller than 0,5 mm using the test sieve (5.4). Weigh to the nearest 0,01 gram approximately 50 grams of the sample into the beaker (5.2). Add sufficient gas oil (section 4) to cover the prills completely and stir carefully to ensure that the surfaces of all the prills are fully wetted. Cover the beaker with a watch glass and leave to stand for one hour at 25 (± 2) °C.
- 6.3. Filter the entire contents of the beaker through the funnel (5.3) containing the test sieve (5.4). Allow the portion retained by the sieve to remain there for one hour so that most of the excess oil can drain away.
- 6.4. Lay two sheets of filter paper (5.5) (about 500 × 500 mm) on top of each other on a smooth surface; fold the four edges of both filter papers upwards to a width of about 40 mm to prevent the prills from rolling away. Place two layers of absorbent tissue (5.6) in the centre of the filter papers. Pour the entire contents of the sieve (5.4) over the absorbent tissues and spread the prills evenly with a soft, flat brush. After two minutes lift one side of the tissues to transfer the prills to the filter papers beneath and spread them evenly over these with the brush. Lay another sheet of filter paper, similarly with its edges turned upward, on the sample and roll the prills between the filter papers with circular movements while exerting a little pressure. Pause after every eight circular movements to lift the opposite edges of the filter papers and return to the centre the prills that have rolled to the periphery. Keep to the following procedure: make four complete circular movements, first clockwise and then anticlockwise. Then roll the prills back to the centre as described above. This procedure to be carried out three times (24 circular movements, edges lifted twice). Carefully insert a new sheet of filter paper between the bottom sheet and the one above it and allow the prills to roll onto the new sheet by lifting the edges of the upper sheet. Cover the prills with a new sheet of filter paper and repeat the same procedure as described above. Immediately after rolling, pour the prills into a tared dish and reweigh to the nearest 0,01 gram to determine the mass of the quantity of gas oil retained.

6.5. *Repeating the rolling procedure and reweighing*

If the quantity of gas oil retained in the portion is found to be greater than 2 grams, place the portion on a fresh set of filter papers and repeat the rolling procedure, lifting the corners in accordance with section 6.4 (two times eight circular movements, lifting once). Then reweigh the portion.

7. **Expression of the results**

7.1. *Method of calculation and formula*

The oil retention, from each determination (6.1) expressed as a percentage by mass of the sieved test portion, is given by the equation:

$$\text{Oil retention} = \frac{m_2 - m_1}{m_1} \times 100$$

where:

m_1 is the mass, in grams, of the sieved test portion (6.2),

m_2 is the mass, in grams, of the test portion according to section 6.4 or 6.5 respectively as the result of the last weighing.

Take as the result the arithmetic mean of the two individual determinations.

Method 3

Determination of the combustible ingredients

1. **Scope and field of application**

This document defines the procedure for the determination of the combustible content of straight ammonium nitrate fertilisers of high nitrogen content.

2. **Principle**

The carbon dioxide produced by inorganic fillers is removed in advance with an acid. The organic compounds are oxidised by means of a chromic acid/sulphuric acid mixture. Carbon dioxide formed is absorbed in a barium hydroxide solution. The precipitate is dissolved in a solution of hydrochloric acid and measured by back-titration with sodium hydroxide solution.

3. **Reagents**

3.1. Analytical-grade chromium (VI) trioxide Cr_2O_3 ;

3.2. Sulphuric acid, 60 % by volume: pour 360 ml of water into a one-litre beaker and carefully add 640 ml of sulphuric acid (density at 20 °C = 1.83 g/ml).

3.3. Silver nitrate: 0,1 mol/l solution.

3.4. *Barium hydroxide*

Weigh out 15 grams of barium hydroxide $[\text{Ba}(\text{OH})_2 \cdot 8\text{H}_2\text{O}]$, and dissolve completely in hot water. Allow to cool and transfer to a one-litre flask. Fill up to the mark and mix. Filter through a pleated filter paper.

3.5. Hydrochloric acid: 0,1 mol/l standard solution.

3.6. Sodium hydroxide: 0,1 mol/l standard solution.

3.7. Bromophenol blue: solution of 0,4 grams per litre in water.

3.8. Phenolphthalein: solution of 2 grams per litre in 60 % by volume ethanol.

3.9. Soda lime: particle dimensions, about 1,0 to 1,5 mm.

3.10. Demineralised water, freshly boiled to remove carbon dioxide.

4. Apparatus

4.1. Standard laboratory equipment, in particular:

- filter crucible with a plate of sintered glass and a capacity of 15 ml; plate diameter: 20 mm; total height: 50 mm; porosity 4 (pore diameter from 5 to 15 μm),
- 600-ml beaker.

4.2. Compressed nitrogen supply.

4.3. Apparatus made up of the following parts and assembled, if possible, by means of spherical ground joints (see Figure 2).

- 4.3.1. Absorption tube A about 200 mm long and 30 mm in diameter filled with soda lime (3.9) kept in place by fibreglass plugs.
- 4.3.2. 500-ml reaction flask B with side arm and a round bottom.
- 4.3.3. Vigreux fractionating column about 150 mm long (C').
- 4.3.4. Double-surface condenser C, 200 mm long.
- 4.3.5. Drechsel bottle D acting as a trap for any excess acid which may distil over.
- 4.3.6. Ice bath E to cool the Drechsel bottle.
- 4.3.7. Two absorption vessels F_1 and F_2 , 32 to 35 mm in diameter, the gas distributor of which comprises a 10 mm disc of low-porosity sintered glass.
- 4.3.8. Suction pump and suction regulating device G comprising a T-shaped glass piece inserted into the circuit, the free arm of which is connected to the fine capillary tube by a short rubber tube fitted with a screw clamp.

Caution: The use of boiling chromic acid solution in an apparatus under reduced pressure is a hazardous operation and requires appropriate precautions.

5. Procedure

5.1. Sample for analysis

Weigh approximately 10 grams of ammonium nitrate to the nearest 0,001 grams.

5.2. Removal of carbonates

Place the sample for analysis in the reaction flask B. Add 100 ml of H_2SO_4 (3.2). The prills dissolve in about 10 minutes at ambient temperature. Assemble the apparatus as indicated in the diagram: connect one end of the absorption tube (A) to the nitrogen source (4.2) via a non-return flow device containing a pressure equivalent to 5 to 6 mm of mercury and the other end to the feed tube which enters the reaction flask. Place the Vigreux fractionating column (C') and the condenser (C) with cooling water supply in position. Adjust the nitrogen to provide a moderate flow through the solution, bring the solution to boiling point and heat for two minutes. At the end of this time there should be no more effervescence. If effervescence is seen, continue heating for 30 minutes. Allow solution to cool for at least 20 minutes with the nitrogen flowing through it.

Complete assembly of the apparatus as indicated in the diagram by connecting the condenser tube to the Drechsel bottle (D) and the bottle to the absorption vessels F_1 and F_2 . The nitrogen must continue to pass through the solution during the assembly operation. Rapidly introduce 50 ml of barium hydroxide solution (3.4) into each of the absorption vessels (F_1 and F_2).

Bubble a stream of nitrogen through for about 10 minutes. The solution must remain clear in the absorbers. If this does not happen, the carbonate removal process must be repeated.

5.3. Oxidation and absorption

After withdrawing the nitrogen feed tube, rapidly introduce 20 grams of chromium trioxide (3.1) and 6 ml of silver nitrate solution (3.3) via the side arm of the reaction flask (B). Connect the apparatus to the suction pump and adjust the nitrogen flow so that a steady stream of gas bubbles passes through the sintered-glass absorbers F₁ and F₂.

Heat the reaction flask (B) until the liquid boils and keep it boiling for one and a half hours⁽¹⁾. It may be necessary to adjust the suction-regulating valve (G) to control the nitrogen flow since it is possible that the barium carbonate precipitated during the test may block the sintered-glass discs. The operation is satisfactory when the barium hydroxide solution in the absorber F₂ remains clear. Otherwise repeat the test. Stop heating and dismantle the apparatus. Wash each of the distributors (3.10) both inside and outside to remove barium hydroxide and collect the washings in the corresponding absorber. Place the distributors one after the other in a 600-ml beaker which will subsequently be used for the determination.

Rapidly filter under vacuum firstly the contents of absorber F₂ and then of absorber F₁ using the sintered-glass crucible. Collect the precipitate by rinsing the absorbers with water (3.10) and wash the crucible with 50 ml of the same water. Place the crucible in the 600-ml beaker and add about 100 ml of boiled water (3.10). Introduce 50 ml of boiled water into each of the absorbers and pass nitrogen through the distributors for five minutes. Combine the water with that from the beaker. Repeat the operation once to ensure that the distributors are rinsed thoroughly.

5.4. Measurement of the carbonates originating from organic material

Add five drops of phenolphthalein (3.8) to the contents of the beaker. The solution becomes red in colour. Add hydrochloric acid (3.5) drop by drop until the pink colour just disappears. Stir the solution well in the crucible to check that the pink colour does not reappear. Add five drops of bromphenol blue (3.7) and titrate with hydrochloric acid (3.5) until the solution turns yellow. Add a further 10 ml of hydrochloric acid.

Heat the solution to boiling point and continue boiling for a maximum of one minute. Check carefully that no precipitate remains in the liquid.

Allow to cool and back titrate with the sodium hydroxide solution (3.6).

6. Blank test

Carry out a blank test following the same procedure and using the same quantities of all reagents.

7. Expression of the results

The content of combustible ingredients (C), expressed as carbon, as a percentage by mass of the sample, is given by the formula:

$$C \% = 0,06 \times \frac{V_1 - V_2}{E}$$

where:

E = the mass in grams of the test portion,

V₁ = the total volume in ml of 0,1 mol/l hydrochloric acid added after the change in colour of the phenolphthalein,

V₂ = the volume in ml of the 0,1 mol/l sodium hydroxide solution used for back titration.

⁽¹⁾ A reaction time of one and a half hours, is sufficient in the case of most of the organic substances in the presence of silver nitrate catalyst.

Figure 2

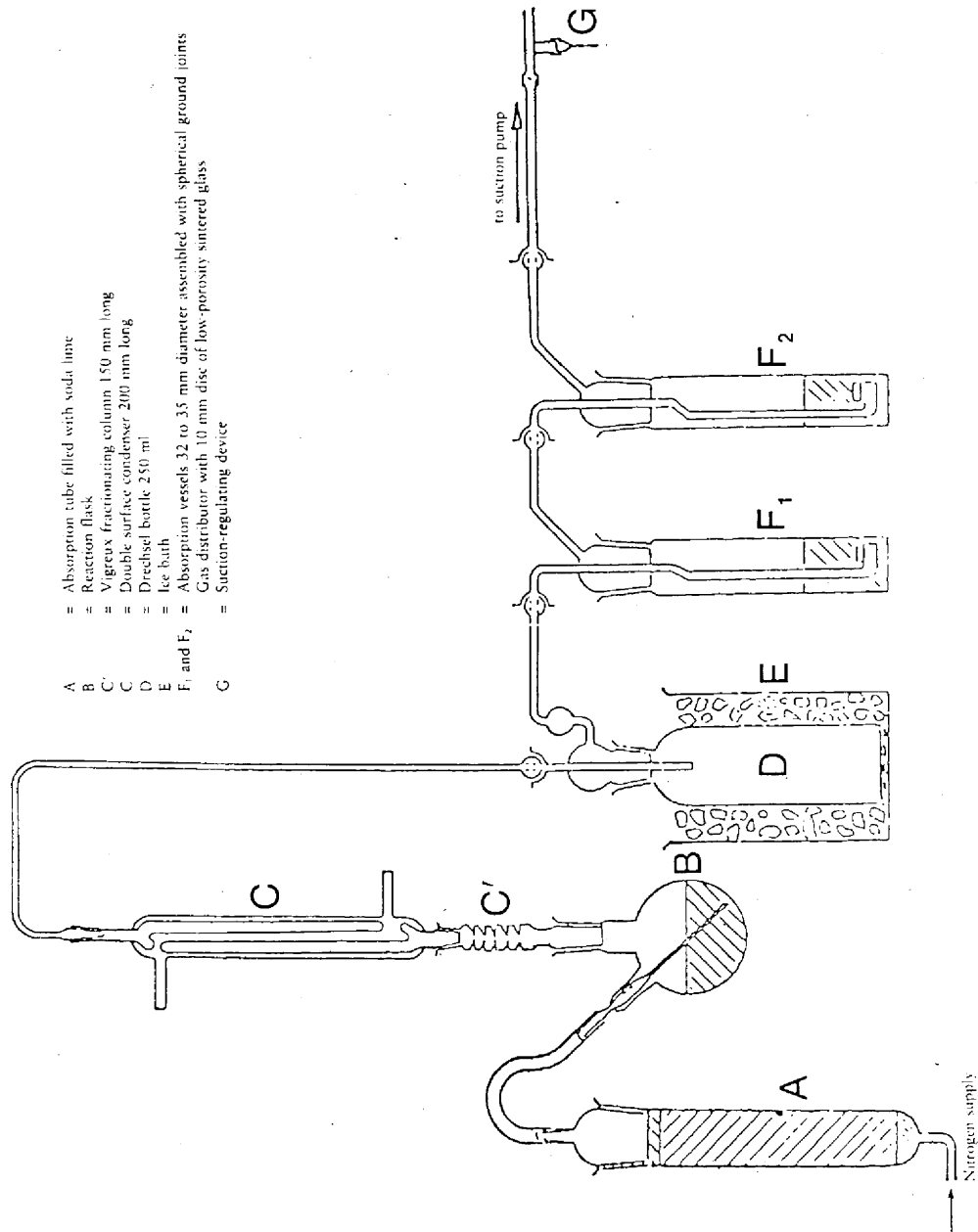

Method 4

Determination of the pH value

1. Scope and field of application

This document defines the procedure for measuring the pH value of a solution of a straight ammonium nitrate fertiliser of high nitrogen content.

2. Principle

Measurement of the pH of an ammonium nitrate solution by means of a pH meter.

3. Reagents

Distilled or demineralised water, free from carbon dioxide.

3.1. *Buffer solution, pH 6,88 at 20 °C*

Dissolve $3,40 \pm 0,01$ grams of potassium dihydrogen orthophosphate (KH_2PO_4) in approximately 400 ml of water. Then dissolve $3,55 \pm 0,01$ grams of disodium hydrogen orthophosphate (Na_2HPO_4) in approximately 400 ml of water. Transfer the two solutions without loss into a 1 000-ml graduated flask, make up to the mark and mix. Keep this solution in an airtight vessel.

3.2. *Buffer solution, pH 4,00 at 20 °C*

Dissolve $10,21 \pm 0,01$ grams of potassium hydrogen phthalate ($\text{KHC}_8\text{O}_4\text{H}_4$) in water, transfer without loss into a 1 000-ml graduated flask, make up to the mark and mix.

Keep this solution in an airtight vessel.

3.3. Commercially available pH standard solutions may be used.

4. **Apparatus**

pH meter, equipped with glass and calomel electrodes or equivalent, sensitivity 0,05 pH unit.

5. **Procedure**

5.1. *Calibration of the pH meter*

Calibrate the pH meter (4) at a temperature of $20 (\pm 1) ^\circ\text{C}$, using the buffer solutions (3.1), (3.2) or (3.3). Pass a slow stream of nitrogen onto the surface of the solution and maintain this throughout the test.

5.2. *Determination*

Pour 100,0 ml of water onto $10 (\pm 0,01)$ grams of the sample in a 250 ml beaker. Remove the insolubles by filtering, decanting or centrifuging the liquid. Measure the pH value of the clear solution at a temperature of $20 (\pm 1) ^\circ\text{C}$ according to the same procedure as for the calibration of the meter.

6. **Expression of the results**

Express the result in pH units, to the nearest 0,1 unit, and state the temperature used.

Method 5

Determination of the particle size

1. **Scope and field of application**

This document defines the procedure for the test sieving of straight ammonium nitrate fertilisers of high nitrogen content.

2. **Principle**

The test sample is sieved on a nest of three sieves, either by hand or by mechanical means. The mass retained on each sieve is recorded and the percentage of material passing the required sieves are calculated.

3. **Apparatus**

3.1. 200-mm-diameter woven-wire test sieves with apertures of 2,0 mm, 1,0 mm and 0,5 mm respectively of standard ranges. One lid and one receiver for these sieves.

3.2. Balance to weigh to 0,1 gram.

3.3. Mechanical sieve shaker (if available) capable of imparting both vertical and horizontal motion to the test sample.

4. **Procedure**

4.1. The sample is divided representatively into portions of approximately 100 grams.

4.2. Weigh one of these portions to the nearest 0,1 gram.

4.3. Arrange the nest of sieves in ascending order; receiver, 0,5 mm, 1 mm, 2 mm and place the weighed test portion on the top sieve. Fit the lid to the top of the nest of sieves.

4.4. Shake by hand or machine, imparting both a vertical and horizontal motion and if by hand, tapping occasionally. Continue this process for 10 minutes or until the quantity passing through each sieve in one minute is less than 0,1 gram.

4.5. Remove the sieves from the nest in turn and collect the material retained, brush gently from the reverse side with a soft brush, if necessary.

4.6. Weigh the material retained on each sieve and that collected in the receiver, to the nearest 0,1 gram.

5. Evaluation of the results

5.1. Convert the fraction masses to a percentage of the total of the fraction masses (not of the original charge).

Calculate the percentage in the receiver (i.e. < 0,5 mm): A %

Calculate the percentage retained on the 0,5 mm sieve: B %

Calculate the percentage passing 1,0 mm, i.e. (A + B) %

The sum of the fraction masses should be within 2 % of the initial mass taken.

5.2. At least two separate analyses should be carried out and the individual results for A should not differ by more than 1,0 % absolute and for B by more than 1,5 % absolute. Repeat the test if this is not the case.

6. Expression of the results

Report the mean of the two values obtained for A on the one hand and for A + B on the other.

Method 6

Determination of the chlorine content (as chloride ion)

1. Scope and field of application

This document defines the procedure for the determination of the chlorine content (as chloride ion) of straight ammonium nitrate fertilisers with a high nitrogen content.

2. Principle

Chloride ions dissolved in water are determined by potentiometric titration with silver nitrate in an acidic medium.

3. Reagents

Distilled or demineralised water, free from chloride ions.

3.1. Acetone AR.

3.2. Concentrated nitric acid (density at 20 °C = 1,40 g/ml)

3.3. Silver nitrate 0,1 mol/l standard solution. Store this solution in a brown glass bottle.

3.4. Silver nitrate 0,004 mol/l standard solution – prepare this solution at the time of use.

3.5. Potassium chloride 0,1 mol/l standard reference solution. Weigh, to the nearest 0,1 mg, 3,7276 grams of analytical-grade potassium chloride, previously dried for one hour in an oven at 130 °C and cooled in a desiccator to ambient temperature. Dissolve in a little water, transfer the solution without loss into a 500-ml standard flask, dilute to the mark and mix.

3.6. Potassium chloride, 0,004 mol/l standard reference solution — prepare this solution at the time of use.

4. Apparatus

4.1. Potentiometer with silver indicating electrode and calomel reference electrode, sensitivity 2 mV, covering the range – 500 to + 500 mV.

4.2. Bridge, containing a saturated potassium nitrate solution, connected to the calomel electrode (4.1), fitted at the ends with porous plugs.

4.3. Magnetic stirrer, with a Teflon-coated rod.

4.4. Microburette with fine-pointed tip, graduated in 0,01 ml divisions.

5. Procedure

5.1. Standardisation of the silver nitrate solution

Take 5,00 ml and 10,00 ml of the standard reference potassium chloride solution (3.6) and place in two low-form beakers of convenient capacity (for example 250 ml). Carry out the following titration of the contents of each beaker.

Add 5 ml of the nitric acid solution (3.2), 120 ml of the acetone (3.1) and sufficient water to bring the total volume to about 150 ml. Place the rod of the magnetic stirrer (4.3) in the beaker and set the stirrer in motion. Immerse the silver electrode (4.1) and the free end of the bridge (4.2) in the solution. Connect the electrodes to the potentiometer (4.1) and, after verifying the zero of the apparatus, note the value of the starting potential.

Titrate, using the microburette (4.4), adding initially 4 or 9 ml respectively of the silver nitrate solution corresponding to the standard reference potassium chloride solution used. Continue the addition in 0,1 ml portions for the 0,004 mol/l solutions and in 0,05 ml portions for the 0,1 mol/l solutions. After each addition, await the stabilisation of the potential.

Record the volumes added and the corresponding values of the potential in the first two columns of a table.

In a third column of the table, record the successive increments (Δ_1E) of the potential E . In a fourth column, record the differences (Δ_2E) positive or negative, between the potential increments (Δ_1E). The end of the titration corresponds to the addition of the 0,1 or 0,05 ml portion (V_1) of the silver nitrate solution which gives the maximum value of Δ_1E .

In order to calculate the exact volume (V_{eq}) of the silver nitrate solution corresponding to the end of the reaction, use the formula:

$$V_{eq} = V_0 + (V_1 \times \frac{b}{B})$$

where:

V_0 is the total volume, in ml, of the silver nitrate solution immediately lower than the volume which gives the maximum increment of Δ_1E ,

V_1 is the volume, in ml, of the last portion of the silver nitrate solution added (0,1 or 0,05 ml),

b is the last positive value of Δ_2E ,

B is the sum of the absolute values of the last positive values of Δ_2E and the first negative value of Δ_2E (see example in Table 1).

5.2. Blank test

Carry out a blank test and take account thereof when calculating the final result.

The result V_4 of the blank test on the reagents is given, in ml, by the formula:

$$V_4 = 2V_3 - V_2$$

where:

V_2 is the value, in ml, of the exact volume (V_{eq}) of the silver nitrate solution corresponding to the titration of 10 ml of the potassium chloride standard reference solution used,

V_3 is the value, in ml, of the exact volume (V_{eq}) of the silver nitrate solution corresponding to the titration of 5 ml of the potassium chloride standard reference solution used.

5.3. Check test

The blank test can at the same time serve as a check that the apparatus is functioning satisfactorily and that the test procedure is being implemented correctly.

5.4. Determination

Take a portion of sample in the range 10 to 20 grams and weigh to the nearest 0,01 gram. Transfer quantitatively to a 250-ml beaker. Add 20 ml of water, 5 ml of nitric acid solution (3.2), 120 ml of acetone (3.1) and sufficient water to bring the total volume to about 150 ml.

Place the rod of the magnetic stirrer (4.3) in the beaker, place the beaker on the stirrer and set the stirrer in motion. Immerse the silver electrode (4.1) and the free end of the bridge (4.2) in the solution, connect the electrodes to the potentiometer (4.1) and, after having verified the zero of the apparatus, note the value of the starting potential.

Titrate with the silver nitrate solution, by additions from the microburette (4.4) in increments of 0,1 ml. After each addition, await the stabilisation of the potential.

Continue the titration as specified in 5.1, starting from the fourth paragraph: 'Record the volumes added and the corresponding values of the potential in the first two columns of a table ...'.

6. Expression of the results

Express the result of the analysis as the percentage of chlorine contained in the sample as received for analysis. Calculate the percentage of chlorine (Cl) content from the formula:

$$\text{Cl \%} = \frac{0,3545 \times T \times (V_5 - V_4) \times 100}{m}$$

where:

T is the concentration of silver nitrate solution used, in mol/l

V_4 is the result, in ml, of the blank test (5.2),

V_5 is the value, in ml, of V_{eq} corresponding to the determination (5.4),

m is the mass, in grams, of the test portion.

Table 1: Example

Volume of the silver nitrate solution V (ml)	Potential E (mV)	$\Delta_1 E$	$\Delta_2 E$
4,80	176		
4,90	211	35	+ 37
5,00	283	72	- 49
5,10	306	23	- 10
5,20	319	13	

$$V_{\text{eq}} = 4,9 + 0,1 \times \frac{37}{37 + 49} = 4,943$$

Method 7

Determination of copper

1. Scope and field of application

This document defines the procedure for the determination of copper content of straight ammonium nitrate fertilisers of high nitrogen content.

2. Principle

The sample is dissolved in dilute hydrochloric acid and the copper is determined by atomic absorption spectrophotometry.

3. Reagents

- 3.1. Hydrochloric acid (density at 20 °C = 1,18 g/ml).
- 3.2. Hydrochloric acid, 6 mol/l solution.
- 3.3. Hydrochloric acid 0,5 mol/l solution.
- 3.4. Ammonium nitrate.
- 3.5. Hydrogen peroxide, 30 % w/v
- 3.6. Copper solution ⁽¹⁾ (stock): weigh, to the nearest 0,001 gram, 1 gram of pure copper, dissolve in 25 ml 6 mol/l hydrochloric acid solution (3.2), add 5 ml of hydrogen peroxide (3.5) in portions and dilute to 1 litre with water. 1 ml of this solution contains 1 000 µg of copper (Cu).
- 3.6.1. Copper solution (dilute): dilute 10 ml of stock solution (3.6) to 100 ml with water and then dilute 10 ml of the resulting solution, to 100 ml with water, 1 ml of the final dilution contains 10 µg of copper (Cu).

Prepare this solution at the time of use.

4. Apparatus

Atomic absorption spectrophotometer with a copper lamp (324,8 nm).

5. Procedure

5.1. Preparation of the solution for analysis

Weigh, to the nearest 0,001 gram, 25 grams of the sample, place it in a 400-ml beaker, add carefully 20 ml of hydrochloric acid (3.1) (there may be a vigorous reaction due to carbon dioxide formation). Add more hydrochloric acid, if necessary. When effervescence has stopped, evaporate to dryness on a steam bath, stirring occasionally with a glass rod. Add 15 ml 6 mol/l hydrochloric acid solution (3.2) and 120 ml of water. Stir with the glass rod, which should be left in the beaker, and cover the beaker with a watch glass. Boil the solution gently until dissolution is complete and then cool.

Transfer the solution quantitatively into a 250-ml graduated flask, by washing the beaker with 5 ml 6 mol/l hydrochloric acid (3.2), and twice with 5 ml of boiling water, make up to the mark with 0,5 mol/l hydrochloric acid (3.3) and mix carefully.

Filter through a copper-free filter paper ⁽²⁾, discarding the first 50 ml.

5.2. Blank solution

Prepare a blank solution from which only the sample has been omitted and allow for this in the calculation of the final results.

5.3. Determination

5.3.1. Preparation of sample and blank test solutions

Dilute the sample solution (5.1) and the blank test solution (5.2) with 0,5 mol/l hydrochloric acid solution (3.3) to a concentration of copper within the optimal measuring range of the spectrophotometer. Normally no dilution is needed.

5.3.2. Preparation of the calibration solutions

By diluting the standard solution (3.6.1) with 0,5 mol/l hydrochloric acid solution (3.3), prepare at least five standard solutions corresponding to the optimal measuring range of the spectrophotometer (0 to 5,0 mg/l Cu). Before making up to the mark, add to every solution ammonium nitrate (3.4) to give concentration of 100 mg per ml.

⁽¹⁾ Commercially available standard copper solution may be used.

⁽²⁾ Whatman 541 or equivalent.

5.4. Measurement

Set up the spectrophotometer (4) at a wavelength of 324,8 nm. Use an oxidising air-acetylene flame. Spray successively, in triplicate, the calibration solution (5.3.2), the sample solution and the blank solution (5.3.1), washing the instrument through with distilled water between each spraying. Plot the calibration curve using the mean absorbances of every standard used as the ordinates and the corresponding concentrations of copper in µg/ml as the abscissae.

Determine the concentration of copper in the final sample and blank solutions by reference to the calibration curve.

6. Expression of the results

Calculate the copper content of the sample taking into account the mass of the test sample, the dilutions carried out in the course of the analysis and the value of the blank. Express the result as mg Cu/kg.

4. Determination of resistance to detonation

4.1. Scope and field of application

This document defines the procedure for the determination or resistance to detonation of ammonium nitrate fertilisers of high nitrogen content.

4.2. Principle

The test sample is confined in a steel tube and subjected to detonation shock from an explosive booster charge. Propagation of the detonation is determined from the degree of crushing of lead cylinders on which the tube rests horizontally during the test.

4.3. Materials

4.3.1. Plastic explosive containing 83 to 86 % penthrite

Density: 1 500 to 1 600 kg/m³

Detonation velocity: 7 300 to 7 700 m/s

Mass: 500 (± 1) gram.

4.3.2. Seven lengths of flexible detonating cord with non-metallic sleeve

Filling mass: 11 to 13 g/m

Length of each cord: 400 (± 2) mm.

4.3.3. Compressed pellet of secondary explosive, recessed to receive detonator

Explosive: hexogen/wax 95/5 or tetryl or similar secondary explosive, with or without added graphite.

Density: 1 500 to 1 600 kg/m³

Diameter: 19 to 21 mm

Height: 19 to 23 mm

Central recess to receive detonator: diameter 7 to 7,3 mm, depth 12 mm.

4.3.4. Seamless steel tube as specified in ISO 65 — 1981 — Heavy Series, with nominal dimensions DN 100 (4")

Outside diameter: 113,1 to 115,0 mm

Wall thickness: 5,0 to 6,5 mm

Length: 1 005 (± 2) mm.

4.3.5. Bottom plate

Material: steel of good weldable quality

Dimensions: 160 × 160 mm

Thickness: 5 to 6 mm

- 4.3.6. Six lead cylinders
Diameter: 50 (± 1) mm
Height: 100 to 101 mm
Materials: soft lead, at least 99,5 % purity.
- 4.3.7. Steel block
Length: at least 1 000 mm
Width: at least 150 mm
Height: at least 150 mm
Mass: at least 300 kg if there is no firm base for the steel block.
- 4.3.8. Plastic or cardboard cylinder for booster charge
Wall thickness: 1,5 to 2,5 mm
Diameter: 92 to 96 mm
Height: 64 to 67 mm
- 4.3.9. Detonator (electric or non-electric) with initiation force 8 to 10
- 4.3.10. Wooden disc
Diameter: 92 to 96 mm. Diameter to be matched to the internal diameter of the plastic or cardboard cylinder (4.3.8)
Thickness: 20 mm
- 4.3.11. Wooden rod of same dimensions as detonator (4.3.9)
- 4.3.12. Dressmaking pins (maximum length 20 mm)
- 4.4. *Procedure*
- 4.4.1. Preparation of booster charge for insertion into steel tube
There are two methods of initiation of the explosive in the booster charge, depending on the availability of equipment.
- 4.4.1.1. Seven-point simultaneous initiation
The booster charge prepared for use is shown in Figure 1.
- 4.4.1.1.1. Drill holes in the wooden disc (4.3.10) parallel to the axis of the disc through the centre and through six points symmetrically distributed around a concentric circle 55 mm in diameter. The diameter of the holes must be 6 to 7 mm (see Section A-B in Figure 1), depending on the diameter of the detonating cord used (4.3.2).
- 4.4.1.1.2. Cut seven lengths of flexible detonating cord (4.3.2) each 400 mm long, avoiding any loss of explosive at each end by making a clean cut and immediately sealing the end with adhesive. Push each of the seven lengths through the seven holes in the wooden disc (4.3.10) until their ends project a few centimetres on the other side of the disc. Then insert a small dressmaking pin (4.3.12) transversally into the textile sleeve of each length of cord 5 to 6 mm from the end and apply adhesive around the outside of the lengths of cord in a band 2 cm wide adjacent to the pin. Finally, pull the long piece of each cord to bring the pin into contact with the wooden disc.
- 4.4.1.1.3. Shape the plastic explosive (4.3.1) to form a cylinder 92 to 96 mm in diameter, depending on the diameter of the cylinder (4.3.8). Stand this cylinder upright on a level surface and insert the shaped explosive. Then insert the wooden disc ⁽¹⁾ carrying the seven lengths of detonating cord into the top of the cylinder and press it down onto the explosive. Adjust the height of the cylinder (64 to 67 mm) so that its top edge does not extend beyond the level of the wood. Finally, fix the cylinder to the wooden disc for instance with staples or small nails, around its entire circumference.
- 4.4.1.1.4. Group the free ends of the seven lengths of detonating cord around the circumference of the wooden rod (4.3.11) so that their ends are all level in a plane perpendicular to the rod. Secure them in a bundle around the rod by means of adhesive tape ⁽²⁾.

⁽¹⁾ The diameter of the disc must always correspond to the inside diameter of the cylinder.

⁽²⁾ NB: When the six peripheral lengths of cord are taut after assembly, the central cord must remain slightly slack.

4.4.1.2. Central initiation by a compressed pellet

The booster charge prepared for use is shown in Figure 2.

4.4.1.2.1. Preparing a compressed pellet

Taking the necessary safety precautions, place 10 grams of a secondary explosive (4.3.3) in a mould with an inside diameter of 19 to 21 mm and compress to the correct shape and density.

(The ratio of diameter: height should be roughly 1:1).

In the centre of the bottom of the mould there is a peg, 12 mm in height and 7,0 to 7,3 mm in diameter (depending on the diameter of the detonator used), which forms a cylindrical recess in the compressed cartridge for subsequent insertion of the detonator.

4.4.1.2.2. Preparing the booster charge

Place the explosive (4.3.1) into the cylinder (4.3.8) standing upright on a level surface, then press it down with a wooden die to give the explosive a cylindrical shape with a central recess. Insert the compressed pellet into this recess. Cover the cylindrically shaped explosive containing the compressed pellet with a wooden disc (4.3.10) having a central hole 7,0 to 7,3 mm in diameter for insertion of a detonator. Fix the wooden disc and the cylinder together with a cross of adhesive tape. Ensure that the hole drilled in the disc and the recess in the compressed pellet are coaxial by inserting the wooden rod (4.3.11).

4.4.2. Preparing steel tubes for the detonation tests

At one end of the steel tube (4.3.4), drill two diametrically opposed holes 4 mm in diameter perpendicularly through the side wall at a distance of 4 mm from the edge.

Butt weld the bottom plate (4.3.5) to the opposite end of the tube, completely filling the right angle between the bottom plate and the wall of the tube with weld metal around the entire circumference of the tube.

4.4.3. Filling and charging the steel tube

See Figures 1 and 2.

4.4.3.1. The test sample, the steel tube and the booster charge must be conditioned to temperatures of 20 (\pm 5) °C. 16 to 18 kg of the test sample are needed for two detonation tests.

4.4.3.2. Place the tube upright with its square bottom plate resting on a firm, flat surface, preferably concrete. Fill the tube to about one-third of its height with the test sample and drop it 10 cm vertically onto the floor five times to compact the prills or granules as densely as possible in the tube. To accelerate compaction, vibrate the tube by striking the side wall with a 750 to 1 000-gram hammer between drops for a total of 10 times.

Repeat this charging method with another portion of the test sample. Finally, a further addition shall be made such that, after compaction by raising and dropping the tube 10 times and a total of 20 intermittent hammer blows, the charge fills the tube to a distance of 70 mm from its orifice.

The filling height of the sample must be adjusted in the steel tube so that the booster charge (4.4.1.1 or 4.4.1.2) to be inserted later will be in close contact with the sample over its entire surface.

4.4.3.3. Insert the booster charge into the tube so that it is in contact with the sample; the top surface of the wooden disc must be 6 mm below the end of the tube. Ensure essential close contact between explosive and test sample by adding or removing small quantities of sample. As shown in Figures 1 and 2, split pins should be inserted through the holes near the open end of the tube and their legs opened flat against the tube.

4.4.4. Positioning of the steel tube and lead cylinders (see figure 3)

4.4.4.1. Number the bases of the lead cylinders (4.3.6) 1 to 6. Make six marks 150 mm apart on the centre line of a steel block (4.3.7) lying on a horizontal base, with the first mark at least 75 mm from the edge of the block. Place a lead cylinder upright on each of these marks, with the base of each cylinder centred on its mark.

- 4.4.4.2. Lay the steel tube prepared according to 4.4.3 horizontally on the lead cylinders so that the axis of the tube is parallel to the centre line of the steel block and the welded end of the tube extends 50 mm beyond lead cylinder No 6. To prevent the tube from rolling, insert small wooden wedges between the tops of the lead cylinders and the tube wall (one on each side) or place a cross of wood between the tube and the steel block.

Note: Make sure that the tube is in contact with all six lead cylinders; a slight curvature of the tube surface can be compensated for by rotating the tube about its longitudinal axis; if any of the lead cylinders is too tall, tap the cylinder in question carefully with a hammer until it is the required height.

- 4.4.5. Preparation for detonation

- 4.4.5.1. Set up the apparatus according to the 4.4.4 in a bunker or suitably prepared underground site (e.g. mine or tunnel). Ensure that the temperature of the steel tube is kept at 20 (\pm 5) °C before detonation.

Note: Should such firing sites not be available, the work can, if necessary, be done in a concrete-lined pit covered over with wooden beams. Detonation can cause steel fragments to be projected with high kinetic energy, therefore, firing must be carried out at a suitable distance from dwellings or thoroughfares.

- 4.4.5.2. If the booster charge with seven-point initiation is used, ensure that the detonation cords are stretched out as described in the footnote to 4.4.1.1.4 and arranged as horizontally as possible.

- 4.4.5.3. Finally, remove the wooden rod and replace with the detonator. Do not carry out firing until the danger zone has been evacuated and the test personnel have taken cover.

- 4.4.5.4. Detonate the explosive.

- 4.4.6. Allow sufficient time for the fumes (gaseous and sometimes toxic decomposition products such as nitrous gases) to disperse, then collect the lead cylinders and measure their heights with a Vernier caliper

Record for each of the marked lead cylinders, the degree of crushing expressed as a percentage of the original height of 100 mm. If the cylinders are crushed obliquely, record the highest and the lowest values and calculate the average.

- 4.4.7. A probe for continuous measurement of the detonation velocity can be used; the probe should be inserted longitudinally to the axis of the tube or along its side wall

- 4.4.8. Two detonation tests per sample are to be carried out

- 4.5. *Test report*

Values for the following parameters are to be given in the test report for each of the detonation tests:

- the values actually measured for the outside diameter of the steel tube and for the wall thickness,
- the Brinell hardness of the steel tube,
- the temperature of the tube and the sample shortly before firing,
- the packing density (kg/m^3) of the sample in the steel tube,
- the height of each lead cylinder after firing, specifying the corresponding cylinder number,
- method of initiation employed for the booster charge.

- 4.5.1. Evaluation of test results

If, in each firing, the crushing of at least one lead cylinder is less than 5 %, the test shall be considered conclusive and the sample in conformity with the requirements of Annex III.2.

Figure 1

Booster charge with seven-point initiation

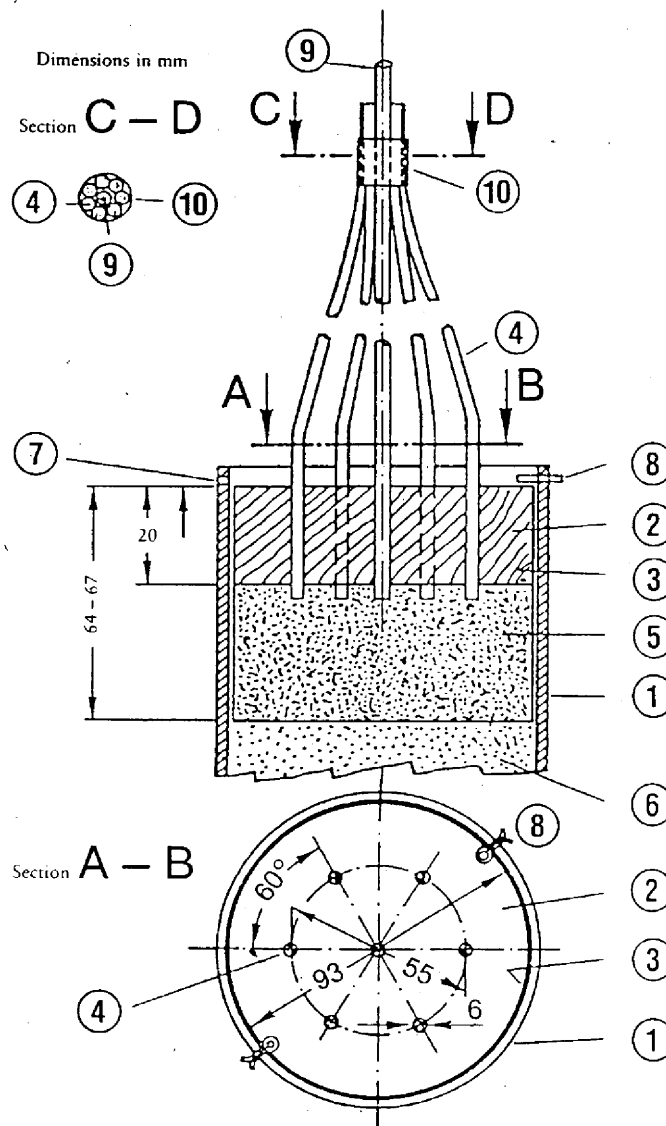

- | | |
|---------------------------------|---|
| ① Steel tube | ⑥ Test sample |
| ② Wooden disc with seven holes | ⑦ 4-mm-diameter hole drilled to receive split pin ⑧ |
| ③ Plastic or cardboard cylinder | ⑧ Split pin |
| ④ Detonating cords | ⑨ Wooden rod surrounded by ④ |
| ⑤ Plastic explosive | ⑩ Adhesive tape for securing ④ around ⑨ |

Figure 2

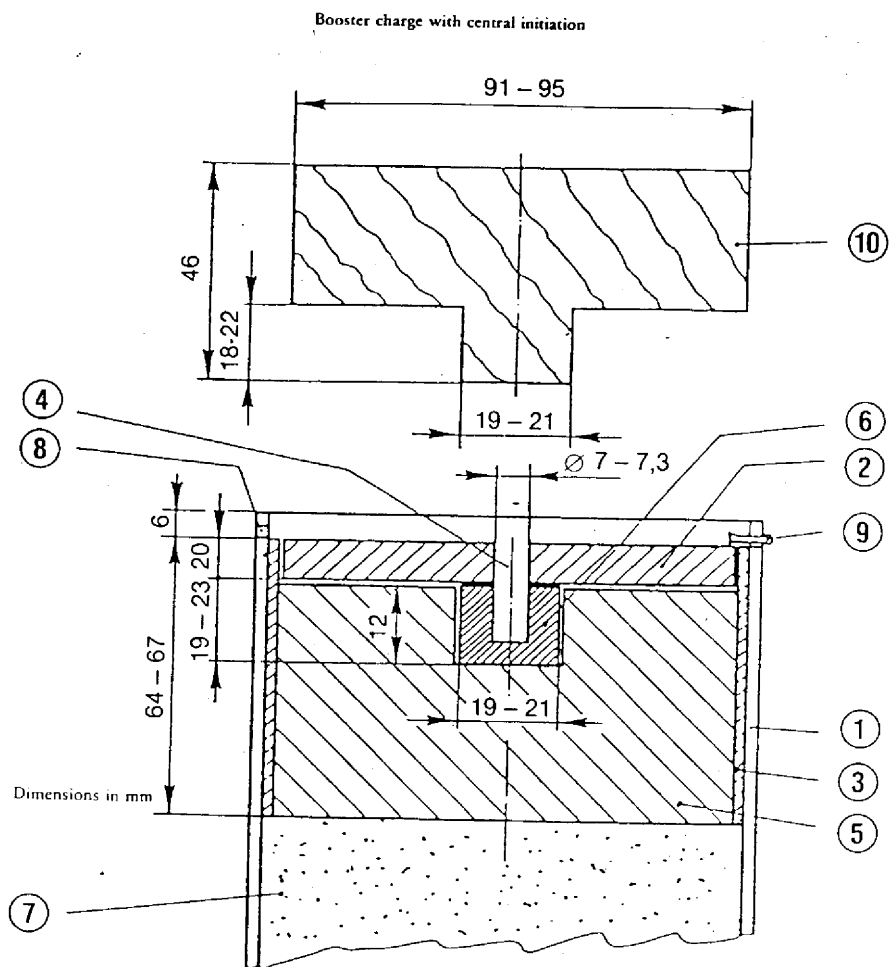

- | | |
|---------------------------------|---|
| ① Steel tube | ⑥ Compressed peller |
| ② Wooden disc | ⑦ Test sample |
| ③ Plastic or cardboard cylinder | ⑧ 4-mm-diameter hole drilled to receive split pin ⑨ |
| ④ Wooden rod | ⑨ Split pin |
| ⑤ Plastic explosive | ⑩ Wooden die for ⑤ |

Figure 3

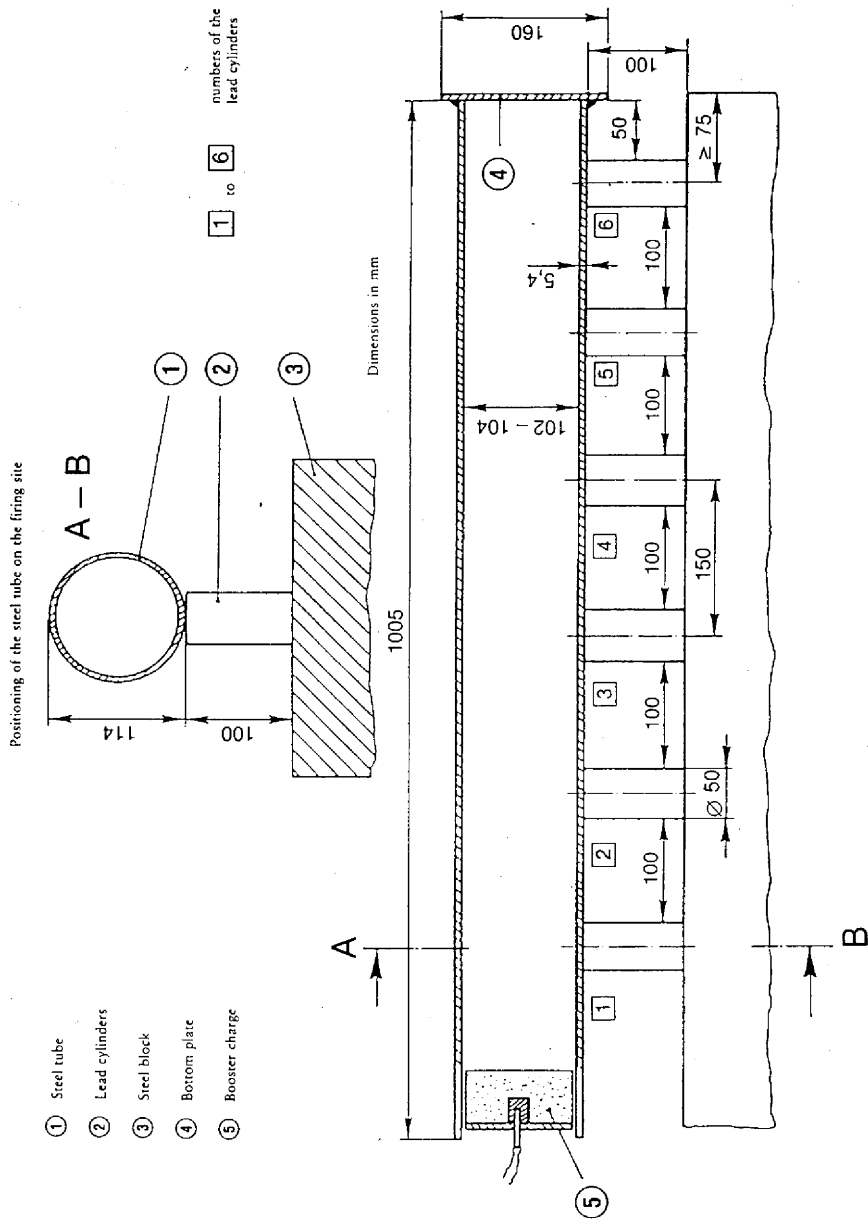

ANNEX IV

METHODS OF SAMPLING AND ANALYSIS

A. METHOD OF SAMPLING FOR THE CONTROL OF FERTILISERS

INTRODUCTION

Correct sampling is a difficult operation which requires the greatest of care. The need to obtain a sufficiently representative sample for the official testing of fertilisers cannot, therefore, be stressed too much.

The sampling method described below must be applied with strict accuracy by specialists with experience of the conventional sampling procedure.

1. **Purpose and scope**

Samples intended for the official control of fertilisers, for quality and composition, shall be taken according to the methods described below. Samples thus obtained shall be considered as representative of the sampled portions.

2. **Sampling officers**

The samples shall be taken by specialist officers authorised for that purpose by the Member States.

3. **Definitions**

Sampled portion: A quantity of product constituting a unit, and having characteristics presumed to be uniform.

Incremental sample: A quantity taken from one point in the sampled portion.

Aggregate sample: An aggregate of incremental samples taken from the same sampled portion.

Reduced sample: A representative part of the aggregate sample, obtained from the latter by a process of reduction.

Final sample: A representative part of the reduced sample.

4. **Apparatus**

4.1. The sampling apparatus must be made of materials which cannot affect the characteristics of the products to be sampled. Such apparatus may be officially approved by the Member States.

4.2. *Apparatus recommended for the sampling of solid fertilisers*

4.2.1. Manual sampling

4.2.1.1. Flat-bottomed shovel with vertical sides.

4.2.1.2. Sampling spear with a long split or compartments. The dimensions of the sampling spear must be appropriate to the characteristics of the sampled portion (depth of container, dimensions of sack, etc.) and to the particle size of the fertiliser.

4.2.2. Mechanical sampling

Approved mechanical apparatus may be used for the sampling of moving fertilisers.

4.2.3. Divider

Apparatus designed to divide the sample into equal parts may be used for taking incremental samples and for the preparation of reduced and final samples.

4.3. *Apparatus recommended for the sampling of fluid fertilisers*

4.3.1. Manual sampling

Open tube, probe, bottle or another appropriate equipment able to take samples at random from the sampled portion.

4.3.2. Mechanical sampling

Approved mechanical apparatus may be used for sampling of moving fluid fertilisers.

5. Quantitative requirements

5.1. Sampled portion

The size of the sampled portion must be such that each of its constituent parts can be sampled.

5.2. Incremental samples

5.2.1. Loose solid fertilisers or fluid fertilisers in containers exceeding 100 kg

5.2.1.1. Sampled portions not exceeding 2,5 tonnes:

Minimum number of incremental samples: seven

5.2.1.2. Sampled portions exceeding 2,5 tonnes and up to 80 tonnes:

Minimum number of incremental samples: $\sqrt{20 \text{ times the number of tonnes making up the sampled portion }^{(1)}}$

5.2.1.3. Sampled portions exceeding 80 tonnes:

Minimum number of incremental samples: 40

5.2.2. Packaged solid fertilisers or fluid fertilisers in containers (= packages each not exceeding 100 kg)

5.2.2.1. Packages of more than 1 kg

5.2.2.1.1. Sampled portions of less than five packages:

Minimum number of packages to be sampled ⁽²⁾: all packages.

5.2.2.1.2. Sampled portions of five to 16 packages:

Minimum number of packages to be sampled ⁽²⁾: four.

5.2.2.1.3. Sampled portions of 17 to 400 packages:

Minimum number of packages to be sampled ⁽²⁾: $\sqrt{\text{number of packages making up the sampled portion }^{(1)}}$

5.2.2.1.4. Sampled portions exceeding 400 packages:

Minimum number of packages to be sampled ⁽²⁾: 20.

5.2.2.2. Packages not exceeding 1 kg:

Minimum number of packages to be sampled ⁽²⁾: four.

5.3. Aggregate sample

A single aggregate sample per sampled portion is required. The total mass of the incremental samples making up the aggregate sample shall be not less than the following:

5.3.1. Loose solid fertilisers or fluid fertilisers in containers exceeding 100 kg: 4 kg.

5.3.2. Packaged solid fertilisers or fluid fertilisers in containers (= packages) each not exceeding 100 kg

5.3.2.1. Packages of more than 1 kg: 4 kg

5.3.2.2. Packages not exceeding 1 kg: mass of the contents of four original packages.

5.3.3. Ammonium nitrate fertiliser sample for tests according to Annex III.2: 75 kg

⁽¹⁾ Where the number obtained is a fraction, it should be rounded up to the next whole number.

⁽²⁾ For packages whose contents do not exceed 1 kg, an incremental sample shall be the contents of one original package.

5.4. *Final samples*

The aggregate sample gives the final samples on reduction when necessary. Analysis of at least one final sample is required. The mass of the sample for analysis shall not be less than 500 g.

5.4.1. Solid and fluid fertilisers

5.4.2. Ammonium nitrate fertiliser sample for tests

The aggregate sample gives the final sample for tests on reduction when necessary.

5.4.2.1. Minimum final sample mass for Annex III.1 tests: 1 kg

5.4.2.2. Minimum final sample mass for Annex III.2 tests: 25 kg

6. **Instructions for taking, preparing and packaging the samples**

6.1. *General*

The samples must be taken and prepared as quickly as possible bearing in mind the precautions necessary to ensure that they remain representative of the fertiliser sampled. Instruments and also surfaces and containers intended to receive samples must be clean and dry.

In the case of fluid fertilisers, if possible the sampled portion should be mixed prior to sampling.

6.2. *Incremental samples*

Incremental samples must be taken at random throughout the whole sampled portion and they must be of approximately equal sizes.

6.2.1. Loose solid fertilisers or fluid fertilisers in containers exceeding 100 kg

An imaginary division shall be made of the sampled portion into a number of approximately equal parts. A number of parts corresponding to the number of incremental samples required in accordance with 5.2 shall be selected at random and at least one sample taken from each of these parts. Where it is not possible to comply with the requirements of 5.1 when sampling bulk fertilisers or fluid fertilisers in containers exceeding 100 kg the sampling should be carried out when the sampled portion is being moved (loading or unloading). In this case samples shall be taken from the randomly selected notional parts as defined above while these are being moved.

6.2.2. Packaged solid fertilisers or fluid fertilisers in containers (= packages) each not exceeding 100 kg

Having selected the required number of packages for sampling as indicated in 5.2, part of the contents of each package shall be removed. Where necessary, the samples shall be taken after emptying the packages separately.

6.3. *Preparation of aggregate sample*

The incremental samples shall be mixed to form a single aggregate sample.

6.4. *Preparation of the final sample*

The material in the aggregate sample shall be carefully mixed ⁽¹⁾.

If necessary the aggregate sample should first be reduced to at least 2 kg (reduced sample) either by using a mechanical divider or by the quartering method.

At least three final samples shall then be prepared, of approximately the same amount and conforming to the quantitative requirements of 5.4. Each sample shall be put into an appropriate air tight container. All necessary precautions shall be taken to avoid any change in the characteristics of the sample.

For the tests of Annex III, sections 1 and 2, the final samples shall be kept at a temperature between 0 °C and 25 °C.

⁽¹⁾ Any lumps shall be broken up (if necessary by separating them out and returning them to the sample).

7. **Packaging of final samples**

The containers or packages shall be sealed and labelled (the total label must be incorporated in the seal) in such a manner that they cannot be opened without damaging the seal.

8. **Sampling record**

A record must be kept of each sampling, permitting each sampled portion to be identified unambiguously.

9. **Destination of samples**

For each sample portion at least one final sample shall be sent as quickly as possible to an authorised analytical laboratory or to the test institution, together with the information necessary for the analysis or the test.

B. METHODS FOR THE ANALYSIS OF FERTILISERS

(See table of contents p. 2.)

General observations

Laboratory equipment

In the descriptions of the methods, general laboratory equipment has not been precisely defined, except that the sizes of flasks and pipettes are given. In all cases laboratory apparatus must be well cleaned, particularly when small quantities of elements are to be determined.

Control tests

Before analysis it is necessary to ensure that all apparatus functions well and that the analytical technique is carried out correctly, using where appropriate chemical compounds of known composition (e.g. ammonium sulphate, mono potassium phosphate, etc.). Nevertheless, the results from analysed fertilisers can indicate wrong chemical composition if the analytical technique is not rigorously followed. On the other hand, a certain number of determinations are empirical and are relative to products of complex chemical composition. It is recommended that where available, laboratories should make use of standard reference fertilisers of well defined composition.

General provisions relating to methods of analysing fertilisers

1. Reagents

Unless otherwise specified in the method of analysis, all of the reagents must be analysis-pur (a.p.). Where micro-nutrients are to be analysed the purity of the reagents must be checked by means of a blank test. Depending upon the result obtained, it might be necessary to conduct a further purification.

2. Water

Where dissolution, dilution, rinsing or washing operations referred to in the methods of analysis do not specify the nature of solvents or diluents the use of water is implied. Normally, the water will have to be demineralised or distilled. In these specific instances, as mentioned in the method of analysis, that water will have to be subjected to specific purification processes.

3. Laboratory equipment

In view of the equipment normally used in inspection laboratories, the apparatus described in the methods of analysis is restricted to special instruments and apparatus or to such demanded by any specific requirements. This equipment must be perfectly clean, above all where small quantities are to be determined. The laboratory will have to ensure the accuracy of any graduated glassware used by referring to appropriate metrological standards.

Method 1

Preparation of the sample for analysis

1. Scope

This document defines the procedure for the preparation of the sample for analysis, taken from the final sample.

2. Principle

The preparation of a final sample received at the laboratory is a series of operations, usually sieving, grinding and mixing, carried out in such a way that:

- on the one hand, the smallest amount weighed out laid down by the methods of analysis is representative of the laboratory sample,
- on the other hand, the fineness of the fertiliser cannot have been changed by the preparation to the extent that its solubility in the various extraction reagents is appreciably affected.

3. Apparatus

Sample divider (optional).

Sieves with apertures of 0,2 and 0,5 mm.

250-ml flasks, stoppered.

Porcelain pestle and mortar or grinder.

4. Choice of treatment to be used

Preliminary remark

If the product is suitable, only a representative part of the final sample need be kept.

4.1. *Final samples which must not be ground*

Calcium nitrate, calcium magnesium nitrate, sodium nitrate, Chile nitrate, calcium cyanamide, nitrogenous calcium cyanamide, ammonium sulphate, ammonium nitrates of over 30 % N, urea, basic slag, natural phosphate rendered partially soluble, precipitated dihydrated dicalcium phosphate, calcined phosphate, aluminium calcium phosphate, soft ground rock phosphate.

4.2. *Final samples which must be divided and part of which must be ground*

These are products in respect of which certain determinations are carried out without previous grinding (fineness of grinding for example) and other determinations after grinding. They include all compound fertilisers containing the following phosphate ingredients: basic slag, aluminium calcium phosphate, calcined phosphate, soft ground rock phosphate and natural phosphate rendered partially soluble. To that end, divide the final sample into two parts, which are as identical as possible, using a sample divider or by quartering.

4.3. *Final samples in respect of which all determinations are carried out on a ground product*

Only a representative part of the final sample need be ground. These are all the other fertilisers on the list which are not to be found under 4.1 and 4.2.

5. Method

The part of the final sample referred to under 4.2 and 4.3 is sieved rapidly through a sieve with apertures of 0,5 mm. The residue is ground roughly so as to obtain a product in which there is a minimum of fine particles, and it is then sieved. The grinding must be done in conditions such that the substance is not appreciably heated. The operation is repeated as many times as is necessary until there is no residue, and it must be effected as quickly as possible in order to prevent any gain or loss of constituents (water, ammonia). The whole ground and sieved product is placed in a clean flask which can be stoppered.

Before any weighing is carried out for the analysis, the whole sample must be thoroughly mixed.

6. Special cases

(a) Fertilisers comprising a blend of several categories of crystals

In this case, separation frequently occurs. It is therefore absolutely essential to crush and pass the sample through a sieve with apertures of 0,200 mm. For example: mixtures of ammonium phosphate and potassium nitrate. The grinding of the whole of the final sample is recommended in the case of these products.

(b) Residue which is difficult to grind and does not contain fertilising substances

Weigh the residue and take account of its mass when calculating the final result.

(c) Products which decompose on heating

Grinding must be carried out in such a way as to avoid any heating. It is preferable in this case to use a mortar for grinding. For example: compound fertilisers containing calcium cyanamide and urea.

(d) Products which are abnormally moist or made into a paste by grinding

To ensure homogeneity, a sieve is to be chosen which has the smallest apertures compatible with the destruction of lumps by hand or with the pestle. This may be the case of mixtures, certain ingredients of which contain water of crystallisation.

Methods 2

Nitrogen

Method 2.1

Determination of ammoniacal nitrogen

1. Scope

This document defines the procedure for the determination of the ammoniacal nitrogen.

2. Field of application

All nitrogenous fertilisers, including compound fertilisers, in which nitrogen is found exclusively either in the form of ammonium salts, or ammonium salts together with nitrates.

It is not applicable to fertilisers containing urea, cyanamide or other organic nitrogenous compounds.

3. Principle

Displacement of ammonia by means of an excess of sodium hydroxide; distillation; determining the yield of ammonia in a given volume of a standard sulphuric acid and titration of the excess acid by means of a standard solution of sodium or potassium hydroxide.

4. Reagents

Distilled or demineralised water, free from carbon dioxide and all nitrogenous compounds.

4.1. Diluted hydrochloric acid: one volume of HCl ($d_{20} = 1,18$ g/ml) plus one volume of water

4.2. Sulphuric acid: 0,1 mol/l

4.3. Sodium or potassium hydroxide solution, carbonate free: 0,1 mol/l

} for variant a.

4.4. Sulphuric acid: 0,2 mol/l

4.5. Sodium or potassium hydroxide solution, carbonate free: 0,2 mol/l

} for variant b (see note 2).

4.6. Sulphuric acid: 0,5 mol/l

4.7. Sodium or potassium hydroxide solution, carbonate free: 0,5 mol/l

} for variant c (see note 2).

4.8. Sodium hydroxide, approximately 30 % NaOH ($d_{20} = 1,33$ g/ml), ammonia free

4.9. Indicator solutions

4.9.1. Mixed indicator

Solution A: Dissolve 1 g of methyl red in 37 ml of sodium hydroxide solution 0,1 mol/l and make up to one litre with water.

Solution B: Dissolve 1 g of methylene blue in water and make up to one litre.

Mix one volume of A with two volumes of B.

This indicator is violet in acid solution, grey in neutral solution and green in alkaline solution. Use 0,5 ml (10 drops) of this indicator solution.

4.9.2. Methyl red indicator solution

Dissolve 0,1 g of methyl red in 50 ml of 95 % ethanol. Make up to 100 ml with water and filter if necessary. This indicator may be used (four to five drops) instead of the preceding one.

4.10. Anti-bump granules of pumice stone, washed in hydrochloric acid and calcined

4.11. Ammonium sulphate for analysis

5. **Apparatus**

5.1. Distillation apparatus consisting of a round-bottomed flask of suitable capacity connected to a condenser by means of a splash head

Note 1

The different types of equipment approved and recommended for this determination are reproduced, showing all the features of construction, in Figures 1, 2, 3 and 4.

5.2. Pipettes of 10, 20, 25, 50, 100 and 200 ml

5.3. A 500-ml graduated flask

5.4. Rotary shaker (35 to 40 turns per minute)

6. **Preparation of the sample**

See Method 1.

7. **Method of analysis**

7.1. *Preparation of the solution*

Carry out a solubility test on the sample in water at room temperature and in the proportion of 2 % (W/V). Weigh to 0,001 g, according to the indications in Table 1, a quantity of 5 or 7 or 10 g of the prepared sample and place it in a 500-ml graduated flask. According to the result of the solubility test, proceed as follows:

(a) Products completely soluble in water

Add to the flask the quantity of water needed to dissolve the sample; shake, and when completely dissolved, make up the volume and mix thoroughly.

(b) Products not completely soluble in water

Add to the flask 50 ml of water and then 20 ml of hydrochloric acid (4.1). Shake. Leave undisturbed until the evolution of carbon dioxide has ceased. Add 400 ml of water and shake for half an hour with the rotary shaker (5.4). Make up the volume with water, mix and filter through a dry filter into a dry receptacle.

7.2. *Analysis of the solution*

According to the variant chosen, place in the receiving flask a measured quantity of standard sulphuric acid as indicated in Table 1. Add the appropriate quantity of the chosen indicator solution (4.9.1 or 4.9.2) and, if necessary, water in order to obtain a volume of at least 50 ml. The end of the extension tube of the condenser must be below the surface of the solution.

Transfer by precision pipette, according to the details given in the table, an aliquot portion⁽¹⁾ of the clear solution, into the distilling flask of the apparatus. Add water in order to obtain a total volume of about 350 ml, and several grains of pumice in order to control the boiling.

(1) The quantity of ammoniacal nitrogen contained in the aliquot part taken according to Table 1 will be approximately:

- 0,05 g for variant a,
- 0,10 g for variant b,
- 0,20 g for variant c.

Assemble the distillation apparatus, and taking care to avoid any loss of ammonia, add to the contents of the distillation flask 10 ml of concentrated sodium hydroxide solution (4.8) or 20 ml of the reagent in the cases where one has used 20 ml hydrochloric acid (4.1) in order to dissolve the test sample. Gradually warm the flask, to avoid boiling vigorously. When boiling commences, distil at the rate of about 100 ml in 10 to 15 minutes; the total volume of distillate should be about 250 ml⁽¹⁾. When no more ammonia is likely to be evolved, lower the receiving flask so that the tip of the condenser extension is above the surface of the liquid.

Test the subsequent distillate by means of an appropriate reagent to ensure that all the ammonia is completely distilled. Wash the condenser extension with a little water and titrate the surplus acid with the standard solution of sodium or potassium hydroxide prescribed for the variant adopted (see note 2).

Note 2

Standard solutions of different strengths may be used for the back titration provided that the volumes used for the titration do not, as far as possible, exceed 40 to 45 ml.

7.3. Blank

Make a blank test under the same conditions and refer to this in the calculation of the final result.

7.4. Control test

Before carrying out analyses, check that the apparatus is working properly and that the correct application of the method is used, using an aliquot part of a freshly prepared solution of ammonium sulphate (4.11) containing the maximum quantity of nitrogen prescribed for the chosen variant.

8. Expression of the result

Express the result of the analysis as the percentage of ammoniacal nitrogen in the fertiliser as received for analysis.

9. Annexes

As specified in Note 1 in 5.1 'Apparatus', Figures 1, 2, 3 and 4 refer to construction features of the different types of equipment used in this document.

Table 1

Determination of the ammoniacal nitrogen and of the ammoniacal and nitrate nitrogen in fertilisers

Table of the weighing, dilution and calculation to be carried out for each of the variants a, b and c of the method

Variant a

Approximate maximum quantity of nitrogen to be distilled: 50 mg.

Sulphuric acid 0,1 mol/l to be placed in the receiving flask: 50 ml.

Back titration with NaOH or KOH 0,1 mol/l.

Declaration (% N)	Amount to be weighed (g)	Dilution (ml)	Solution of sample to be distilled (ml)	Expression of the result (a) (% N = (50 — A) F)
0-5	10	500	50	(50 — A) × 0,14
5-10	10	500	25	(50 — A) × 0,28
10-15	7	500	25	(50 — A) × 0,40
15-20	5	500	25	(50 — A) × 0,56
20-40	7	500	10	(50 — A) × 1,00

(a) For the purposes of the formula for expression of the result:

— 50 or 35 = millilitres of standard solution of sulphuric acid to be placed in the receiving flask;

— A = millilitres of sodium or potassium hydroxide used for the back titration;

— F = factor comprising the amount weighed, the dilution, the aliquot part of solution of the sample to be distilled and the volumetric equivalent.

⁽¹⁾ The condenser must be regulated so that a continuous flow of condensate is ensured. The distillation should be completed in 30 to 40 minutes.

Variant b

Approximate maximum quantity of nitrogen to be distilled: 100 mg.

Sulphuric acid 0,2 mol/l to be placed in the receiving flask: 50 ml.

Back titration with NaOH or KOH 0,2 mol/l.

Declaration (% N)	Amount to be weighed (g)	Dilution (ml)	Solution of sample to be distilled (ml)	Expression of the result (a) (% N = (50 — A) F)
0-5	10	500	100	$(50 - A) \times 0,14$
5-10	10	500	50	$(50 - A) \times 0,28$
10-15	7	500	50	$(50 - A) \times 0,40$
15-20	5	500	50	$(50 - A) \times 0,56$
20-40	7	500	20	$(50 - A) \times 1,00$

(a) For the purposes of the formula for expression of the result:

- 50 or 35 = millilitres of standard solution of sulphuric acid to be placed in the receiving flask;
- A = millilitres of sodium or potassium hydroxide used for the back titration;
- F = factor comprising the amount weighed, the dilution, the aliquot part of solution of the sample to be distilled and the volumetric equivalent.

Variant c

Approximate maximum quantity of nitrogen to be distilled: 200 mg.

Sulphuric acid 0,5 mol/l to be placed in the receiving flask: 35 ml.

Back titration with NaOH or KOH 0,5 mol/l.

Declaration (% N)	Amount to be weighed (g)	Dilution (ml)	Solution of sample to be distilled (ml)	Expression of the result (a) (% N = (35 — A) F)
0-5	10	500	200	$(35 - A) \times 0,175$
5-10	10	500	100	$(35 - A) \times 0,350$
10-15	7	500	100	$(35 - A) \times 0,500$
15-20	5	500	100	$(35 - A) \times 0,700$
20-40	5	500	50	$(35 - A) \times 1,400$

(a) For the purposes of the formula for expression of the result:

- 50 or 35 = millilitres of standard solution of sulphuric acid to be placed in the receiving flask;
- A = millilitres of sodium or potassium hydroxide used for the back titration;
- F = factor comprising the amount weighed, the dilution, the aliquot part of solution of the sample to be distilled and the volumetric equivalent.

Figure 1

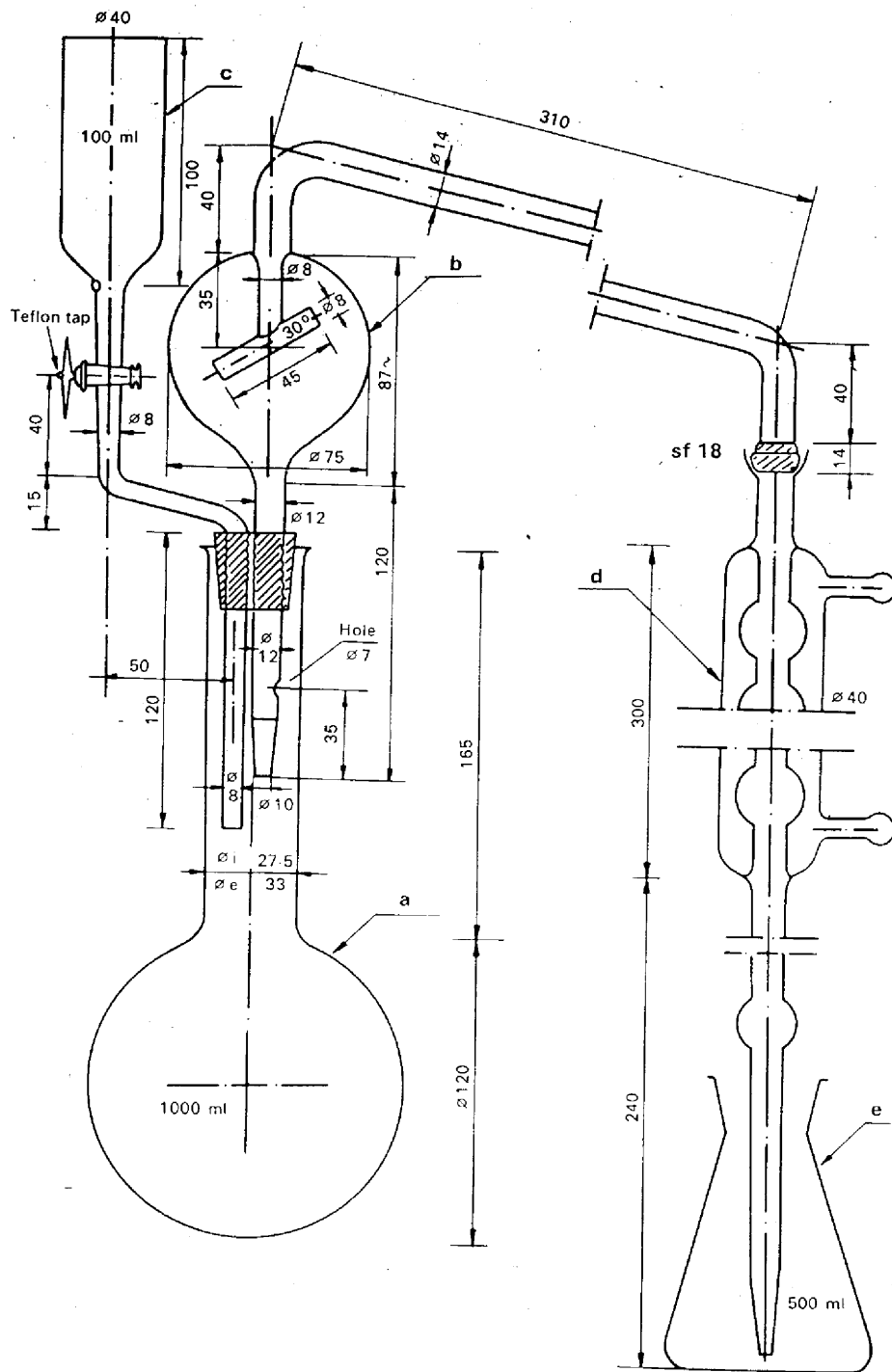

Figure 2

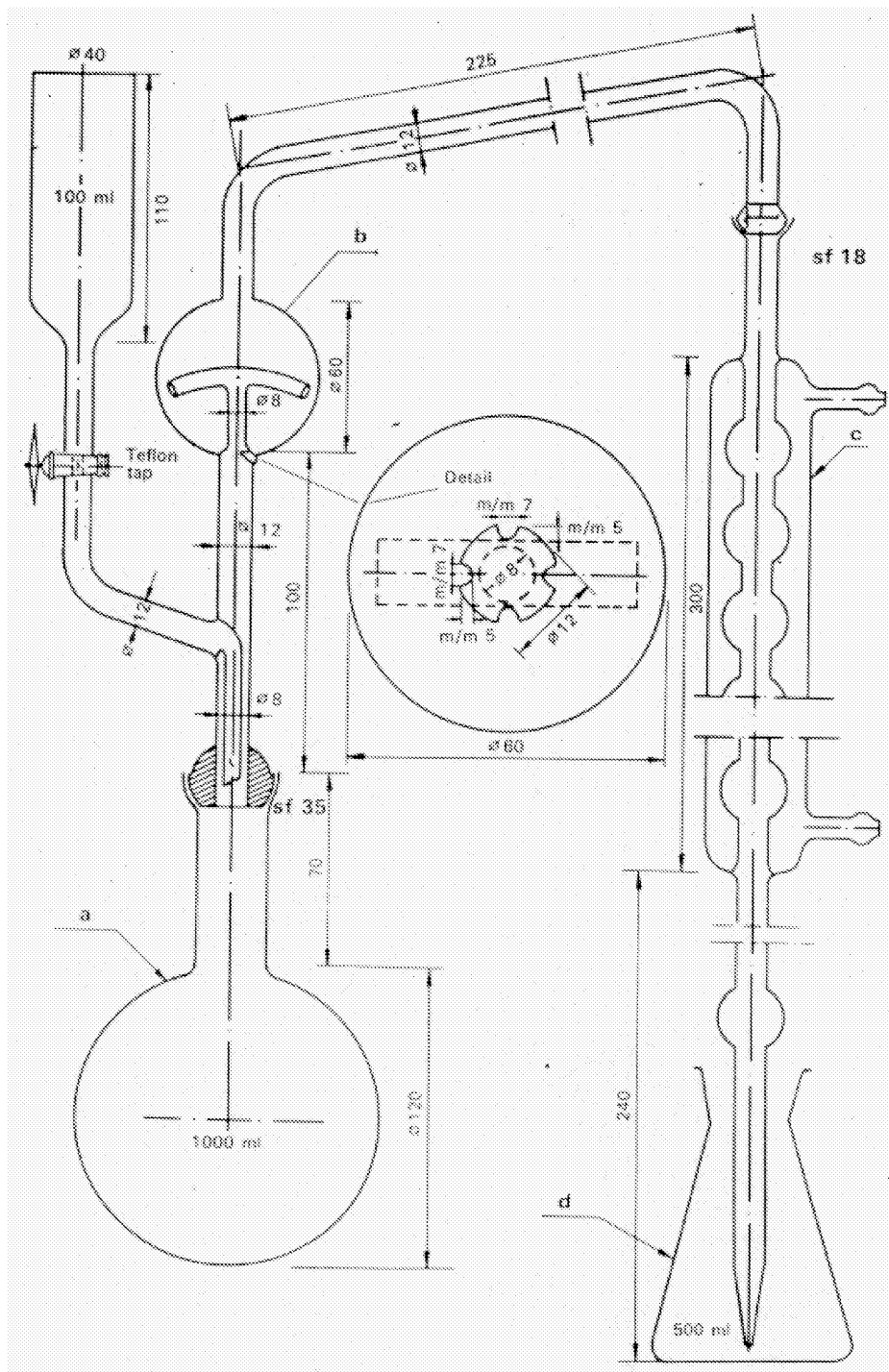

Figure 3

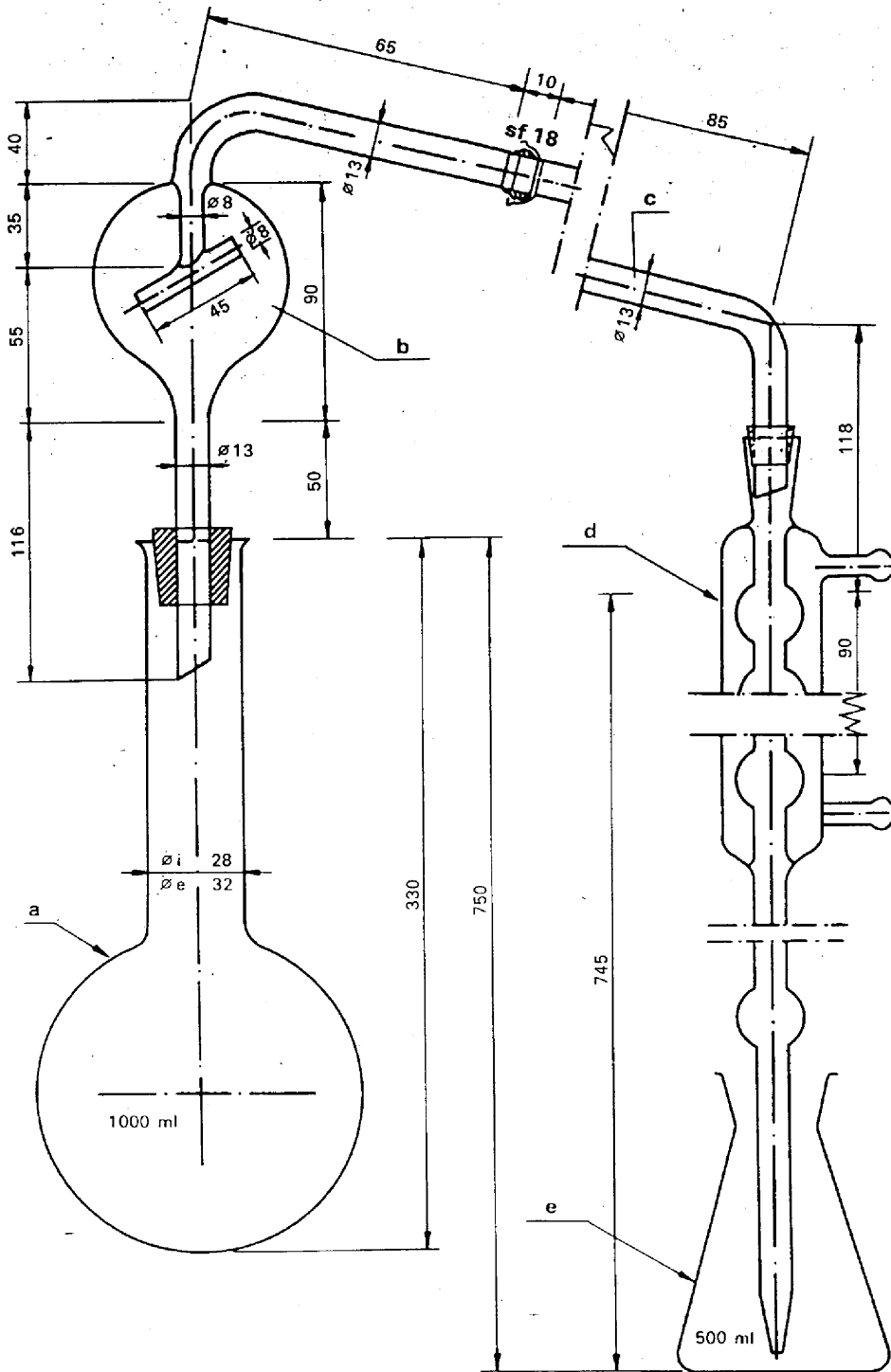
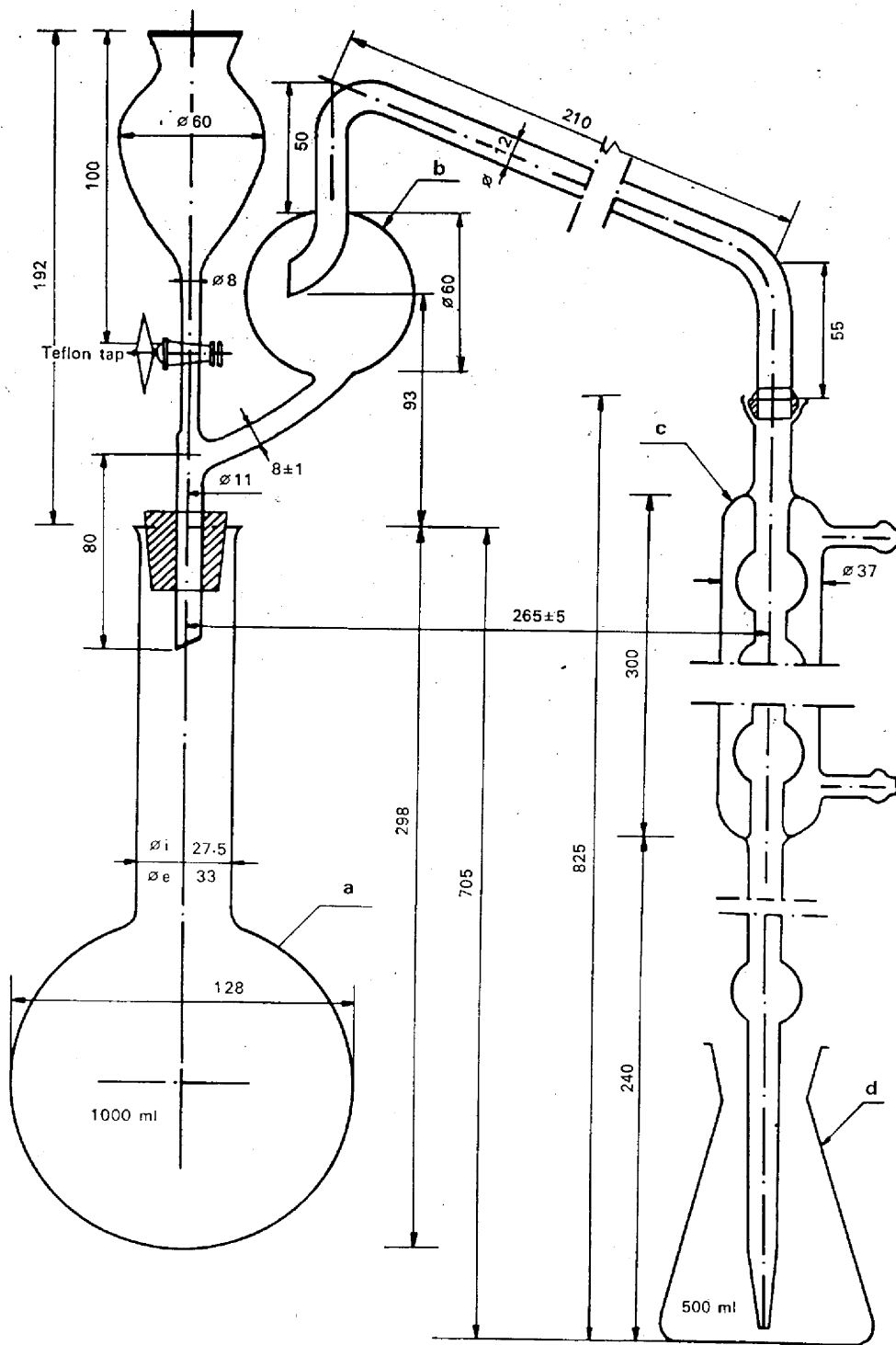

Figure 4



Key to Figures 1, 2, 3 and 4

Figure 1

- (a) A round-bottomed, long-necked flask of 1 000 ml capacity.
- (b) Distillation tube with a splash head, connected to the condenser by means of a spherical joint (No 18) (the spherical joint for the connection to the condenser may be replaced by an appropriate rubber connection).
- (c) Funnel with a teflon tap for the addition of sodium hydroxide (the tap may likewise be replaced by a rubber connection with a clip).
- (d) A six-bulb condenser with spherical joint (No 18) at the entrance, and joined at the issue to a glass extension tube by means of a small rubber connection (when the connection to the distillation tube is effected by means of a rubber tube, the spherical joint may be replaced by a suitable rubber bung).
- (e) A 500-ml flask in which the distillate is collected.

The equipment is made of borosilicate glass.

Figure 2

- (a) A round-bottomed, short-necked flask of 1 000 ml capacity with a spherical joint (No 35).
- (b) Distillation tube with a splash head, equipped with a spherical joint (No 35) at the entrance and a spherical joint (No 18) at the issue, connected at the side to a funnel with a teflon tap for the addition of sodium hydroxide.
- (c) A six-bulb condenser with a spherical joint (No 18) at the entrance and joined at the issue to a glass extension tube by means of a small rubber connection.
- (d) A 500-ml flask in which the distillate is collected.

The equipment is made of borosilicate glass.

Figure 3

- (a) A round-bottomed, long-necked flask of 750 or 1 000 ml capacity with a bell mouth.
- (b) Distillation tube with a splash head and a spherical joint (No 18) at the issue.
- (c) An elbow tube with a spherical joint (No 18) at the entrance, and a drip cone (the connection to the distillation tube may be effected by means of a rubber tube instead of a spherical joint).
- (d) A six-bulb condenser joined at the issue to a glass extension tube by means of a small rubber connection.
- (e) A 500-ml flask in which the distillate is collected.

The equipment is made of borosilicate glass.

Figure 4

- (a) A round-bottomed, long-necked flask of 1 000 ml capacity with a bell mouth.
- (b) Distillation tube with a splash head and a spherical joint (No 18), at the issue, connected at the side to a funnel with a teflon tap for the addition of sodium hydroxide (a suitable rubber bung may be used instead of the spherical joint; the tap may be replaced by a rubber connection with an appropriate clip).
- (c) A six-bulb condenser with a spherical joint (No 18) at the entrance, joined at the issue, by a rubber connection, to a glass extension tube (when the connection to the distillation tube is effected by means of a rubber tube, the spherical joint may be replaced by a suitable rubber bung).
- (d) A 500-ml flask for the collection of the distillate.

The equipment is made of borosilicate glass.

Methods 2.2

Determination of nitric and ammoniacal nitrogen

Methods 2.2.1

Determination of nitric and ammoniacal nitrogen according to Ulsch**1. Scope**

This document defines the procedure for the determination of nitrate and ammoniacal nitrogen with reduction according to Ulsch.

2. Field of application

All nitrogenous fertilisers, including compound fertilisers, in which nitrogen is found exclusively in nitrate form, or in ammoniacal and nitrate form.

3. Principle

Reduction of nitrates and nitrites to ammonia by means of metallic iron in an acid medium, and displacement of the ammonia thus formed by the addition of an excess of sodium hydroxide: distillation of the ammonia, and determination of the yield of ammonia in a known volume of standard sulphuric acid solution. Titration of the excess sulphuric acid by means of a standard solution of sodium or potassium hydroxide.

4. Reagents

Distilled or demineralised water, free from carbon dioxide and all nitrogenous compounds.

4.1. Dilute hydrochloric acid: one volume of HCl ($d_{20} = 1,18$ g/ml) plus one volume of water

4.2. Sulphuric acid: 0,1 mol/l

4.3. Sodium or potassium hydroxide solution, carbonate free: 0,1 mol/l

4.4. Sulphuric acid solution, approximately 30 % H_2SO_4 (W/V), ammonia free

4.5. Powdered iron reduced in hydrogen (the prescribed quantity of iron must be able to reduce at least 0,05 g of nitrate nitrogen)

4.6. Sodium hydroxide solution, approximately 30 % NaOH ($d_{20} = 1,33$ g/ml), ammonia free

4.7. Indicator solutions**4.7.1. Mixed indicator**

Solution A: Dissolve 1 g of methyl red in 37 ml of 0,1 mol/l sodium hydroxide solution and make up to one litre with water.

Solution B: Dissolve 1 g of methylene blue in water and make up to one litre.

Mix one volume of A with two volumes of B.

This indicator is violet in acid solution, grey in neutral solution and green in alkaline solution. Use 0,5 ml (10 drops).

4.7.2. Methyl red indicator solution

Dissolve 0,1 g of methyl red in 50 ml of 95 % ethanol. Make up to 100 ml with water and filter if necessary.

This indicator may be used (four to five drops) instead of the preceding one.

4.8. Anti-bump granules of pumice stone, washed in hydrochloric acid and calcined

4.9. Sodium nitrate for analysis

5. Apparatus

See Method 2.1 'Determination of ammoniacal nitrogen'.

6. Preparation of the sample

See Method 1 'Preparation of the sample'.

7. Method of analysis**7.1. Preparation of the solution**

See Method 2.1 'Determination of ammoniacal nitrogen'.

7.2. Procedure

Place in the receiving flask an exactly measured quantity of 50 ml of standard sulphuric acid as indicated in Table 1 of Method 2.1 (variant a) and add the appropriate quantity of indicator solution 4.7.1 or 4.7.2. The end of the extension tube of the condenser must be below the surface of the standard acid in the receiving flask.

Using a precision pipette, transfer an aliquot part of the clear solution as indicated in Table 1 of Method 2.1 (variant a) and place it in the distilling flask of the apparatus. Add 350 ml of water, 20 ml of 30 % sulphuric acid solution (4.4) stir, and add 5 g of reduced iron (4.5). Wash the neck of the flask with several millilitres of water, and place in the neck of the flask a small, long-stemmed funnel. Heat in a boiling water bath for an hour and then wash the stem of the funnel with a few millilitres of water.

Taking care to avoid any loss of ammonia, add to the contents of the distilling flask 50 ml of concentrated sodium hydroxide solution (4.6), or in the cases where 20 ml of hydrochloric acid (1 + 1) (4.1) has been used to dissolve the sample, add 60 ml of concentrated sodium hydroxide solution (4.6). Assemble the distillation apparatus. Distil the ammonia according to the procedure given in Method 2.1.

7.3. Blank test

Carry out a blank test (omitting the sample) under the same conditions and refer to this in the calculation of the final result.

7.4. Control test

Before analysis, check that the apparatus is working properly and that the correct application of the method is used by using an aliquot part of a freshly prepared solution of sodium nitrate (4.9) containing 0,045 to 0,050 g of nitrogen.

8. Expression of the result

Express the result of analysis as a percentage of nitrate nitrogen or combined ammoniacal and nitrate nitrogen contained in the fertiliser as received for analysis.

Method 2.2.2**Determination of nitric and ammoniacal nitrogen according to Arnd****1. Scope**

This document defines the procedure for the determination of nitric and ammoniacal nitrogen with reduction according to Arnd (modified for each of the variants a, b and c).

2. Field of application

See Method 2.2.1.

3. Principle

Reduction of nitrates and nitrites to ammonia in a neutral aqueous solution by means of a metallic alloy composed of 60 % Cu and 40 % Mg (Arnd's alloy) in the presence of magnesium chloride (MgCl₂).

Distillation of the ammonia, and determination of the yield in a known volume of standard sulphuric acid solution. Titration of the excess acid by means of a standard solution of sodium or potassium hydroxide.

4. Reagents

Distilled or demineralised water, free from carbon dioxide and all nitrogenous compounds.

- 4.1. Dilute hydrochloric acid: one volume of HCl ($d = 1,18$) plus one volume of water
- 4.2. Sulphuric acid: 0,1 mol/l
- 4.3. Sodium or potassium hydroxide solution, carbonate free: 0,1 mol/l
- 4.4. Sulphuric acid: 0,2 mol/l
- 4.5. Sodium or potassium hydroxide solution, carbonate free: 0,2 mol/l
- 4.6. Sulphuric acid: 0,5 mol/l
- 4.7. Sodium or potassium hydroxide solution, carbonate free: 0,5 mol/l
- 4.8. Sodium hydroxide solution: approximately 2 mol/l
- 4.9. Arnd's alloy for analysis: powdered so as to pass through a sieve with apertures less than 1 mm square
- 4.10. 20 % *magnesium chloride solution*
- Dissolve 200 g of magnesium chloride ($MgCl_2 \cdot 6H_2O$) in approximately 600 to 700 ml of water in a one-litre, flat-bottomed flask. To prevent frothing, add 15 g of magnesium sulphate ($MgSO_4 \cdot 7H_2O$).
- After dissolution add 2 g of magnesium oxide and a few anti-bump granules of pumice stone, and concentrate the suspension to 200 ml by boiling, thus expelling any trace of ammonia from the reagents. Cool, make up the volume to one litre and filter.
- 4.11. *Indicator solutions*
- 4.11.1. Mixed indicator
- Solution A: Dissolve 1 g of methyl red in 37 ml of 0,1 mol/l sodium hydroxide solution and make up to one litre with water.
- Solution B: Dissolve 1 g of methylene blue in water and make up to one litre.
- Mix one volume of A with two volumes of B.
- This indicator is violet in acid solution, grey in neutral solution and green in alkaline solution. Use 0,5 ml (10 drops).
- 4.11.2. Methyl red indicator solution
- Dissolve 0,1 g of methyl red in 50 ml of 95 % ethanol. Make up to 100 ml with water and filter if necessary. This indicator may be used (four or five drops) instead of the preceding one.
- 4.11.3. Congo red indicator solution
- Dissolve 3 g of Congo red in one litre of warm water and filter if necessary after cooling. This indicator may be used, instead of the two described above, in the neutralisation of acid extracts before distillation, using 0,5 ml per 100 ml of liquid to be neutralised.
- 4.12. Anti-bump granules of pumice stone washed in hydrochloric acid and calcined
- 4.13. Sodium nitrate for analysis
5. **Apparatus**
- See Method 2.1 'Determination of ammoniacal nitrogen'.
6. **Preparation of the sample**
- See Method 1.

7. Method of analysis**7.1. Preparation of the solution for analysis**

See Method 2.1 'Determination of ammoniacal nitrogen'.

7.2. Analysis of the solution

According to the chosen variant, place in the receiving flask the exactly measured quantity of standard sulphuric acid as indicated in Table 1 of Method 2.1. Add the appropriate quantity of chosen indicator solution (4.11.1 or 4.11.2) and finally, sufficient water to give a volume of at least 50 ml. The end of the extension tube of the condenser must be below the surface of the solution.

Using a precision pipette, take, according to Table 1, an adequate aliquot of the clear solution. Place it in the distillation flask.

Add sufficient water to obtain a total volume of about 350 ml (see note 1), 10 g of Arnd's alloy (4.9), 50 ml of magnesium chloride solution (4.10) and a few fragments of pumice stone (4.12). Rapidly connect the flask to the distillation apparatus. Heat gently for about 30 minutes. Then increase the heating to distil the ammonia. Continue the distillation for about an hour. After this time, the residue in the flask ought to have a syrupy consistency. When the distillation has finished, titrate the quantity of excess acid in the receiving flask according to the procedure in Method 2.1.

Note 1

When the sample solution is acid (addition of 20 ml of HCl (4.1) to dissolve the sample) the aliquot part taken for analysis is neutralised in the following way: to the distillation flask containing the taken aliquot part add about 250 ml of water, the necessary quantity of one of the indicators (4.11.1, 4.11.2, 4.11.3) and shake carefully.

Neutralise with 2 mol/l sodium hydroxide solution (4.8) and acidify again with a drop of hydrochloric acid (4.1). Then proceed as indicated in 7.2 (second line).

7.3. Blank test

Carry out a blank test (omitting the sample) under the same conditions and refer to this in the calculation of the final result.

7.4. Control test

Before analysis, check that the apparatus is working properly and that the correct technique is applied using a freshly prepared solution of sodium nitrate (4.13) containing 0,050 to 0,150 g of nitrate nitrogen depending on the variant chosen.

8. Expression of the result

See Method 2.2.1.

Method 2.2.3**Determination of nitric and ammoniacal nitrogen according to Devarda****1. Scope**

This document defines the procedure for the determination of nitrate and ammoniacal nitrogen with reduction according to Devarda (modified for each of the variants a, b and c).

2. Field of application

See Method 2.2.1.

3. Principle

Reduction of nitrates and nitrites to ammonia in a strongly alkaline solution by means of a metallic alloy composed of 45 % Al, 5 % Zn and 50 % Cu (Devarda alloy). Distillation of the ammonia and determination of the yield in a known volume of standard sulphuric acid; titration of the excess sulphuric acid by means of a standard solution of sodium or potassium hydroxide.

4. Reagents

Distilled or demineralised water, free from carbon dioxide and all nitrogenous compounds.

4.1. Dilute hydrochloric acid: one volume of HCl ($d = 1,18$) plus one volume of water

4.2. Sulphuric acid: 0,1 mol/l

4.3. Sodium or potassium hydroxide solution, carbonate free: 0,1 mol/l

} for variant a.

4.4. Sulphuric acid: 0,2 mol/l

4.5. Sodium or potassium hydroxide solution, carbonate free: 0,2 mol/l

} for variant b (see note 2, Method 2.1).

4.6. Sulphuric acid: 0,5 mol/l

4.7. Sodium or potassium hydroxide solution, carbonate free: 0,5 mol/l

} for variant c (see note 2, Method 2.1).

4.8. *Devarda alloy for analysis*

Powdered so that 90 to 100 % will pass through a sieve with apertures less than 0,25 mm square, 50 to 75 % will pass through a sieve with apertures of less than 0,075 mm square.

Pre-packed bottles containing a maximum of 100 g are recommended.

4.9. Sodium hydroxide solution, approximately 30 % NaOH ($d_{20} = 1,33$ g/ml), ammonia free

4.10. *Indicator solutions*

4.10.1. Mixed indicator

Solution A: Dissolve 1 g of methyl red in 37 ml of 0,1 mol/l sodium hydroxide solution and make up to one litre with water.

Solution B: Dissolve 1 g of methylene blue in water and make up to one litre.

Mix one volume of A with two volumes of B.

This indicator is violet in acid solution, grey in neutral solution and green in alkaline solution. Use 0,5 ml (10 drops).

4.10.2. Methyl red indicator

Dissolve 0,1 g of methyl red in 50 ml of 95 % ethanol. Make up to 100 ml with water and filter if necessary.

This indicator (four or five drops) may be used instead of the preceding one.

4.11. Ethanol, 95 to 96 %

4.12. Sodium nitrate for analysis

5. Apparatus

See Method 2.1.

5.1. Distillation apparatus consisting of a round-bottomed flask of suitable capacity, connected to a condenser by a distilling tube with a splash head, equipped, in addition, with a bubble trap on the receiving flask to prevent any loss of ammonia.

The type of apparatus approved for this determination is reproduced, showing all the features of construction, in Figure 5.

5.2. Pipettes of 10, 20, 25, 50, 100 and 200 ml

5.3. A 500-ml graduated flask

5.4. Rotary shaker (35 to 40 turns a minute)

6. **Preparation of the sample**

See Method 1.

7. **Procedure**

7.1. *Preparation of the solution for analysis*

See Method 2.1 'Determination of ammoniacal nitrogen'.

7.2. *Analysis of the solution*

The quantity of nitric nitrogen present in the aliquot part of the solution must not exceed the maximum quantity expressed in Table 1.

According to the variant chosen, place in the receiving flask an exactly measured quantity of standard sulphuric acid as indicated in Table 1. Add the appropriate quantity of the chosen indicator solution (4.10.1 or 4.10.2) and finally, sufficient water to give a volume of 50 ml. The end of the extension tube of the condenser must be underneath the surface of the solution. Fill the bubble trap with distilled water.

Using a precision pipette, take an aliquot part as indicated in Table 1 of Method 2.1. Place it in the distillation flask.

Add sufficient water to the distillation flask to obtain a volume of 250 to 300 ml, 5 ml ethanol (4.11) and 4 g Devarda's alloy (4.8) (See note 2).

Taking the necessary precautions to avoid loss of ammonia, add to the flask about 30 ml of 30 % sodium hydroxide solution (4.9) and finally, in the case of acid soluble samples an additional quantity sufficient to neutralise the quantity of hydrochloric acid (4.1) present in the aliquot part taken for the analysis. Connect the distillation flask to the apparatus, ensuring the tightness of connections. Carefully shake the flask to mix the contents.

Warm gently, so that the release of hydrogen decreases appreciably over about half an hour and the liquid will boil. Continue the distillation, increasing the heat so that at least 200 ml liquid distils in about 30 minutes (do not prolong the distillation beyond 45 minutes).

When the distillation is complete, disconnect the receiving flask from the apparatus, carefully wash the extension tube and bubble trap, collecting the rinsings in the titration flask. Titrate the excess acid according to the procedure in Method 2.1.

Note 2

In the presence of calcium salts such as calcium nitrate and calcium ammonium nitrate, it is necessary to add before distillation for each gram of sample present in the aliquot, 0,700 g sodium phosphate ($\text{Na}_2\text{HPO}_4 \cdot 2\text{H}_2\text{O}$) to prevent the formation of $\text{Ca}(\text{OH})_2$.

7.3. *Blank test*

Carry out a blank test (omitting the sample) under the same conditions and refer to this in the calculation of the final results.

7.4. *Control test*

Before carrying out the analysis, check that the apparatus is working properly and that the correct application of the method is used, using an aliquot of a freshly prepared solution of sodium nitrate (4.12) containing, according to the variant chosen, 0,050 to 0,150 g of nitrate nitrogen.

8. **Expression of the result**

See Method 2.2.1.

Figure 5

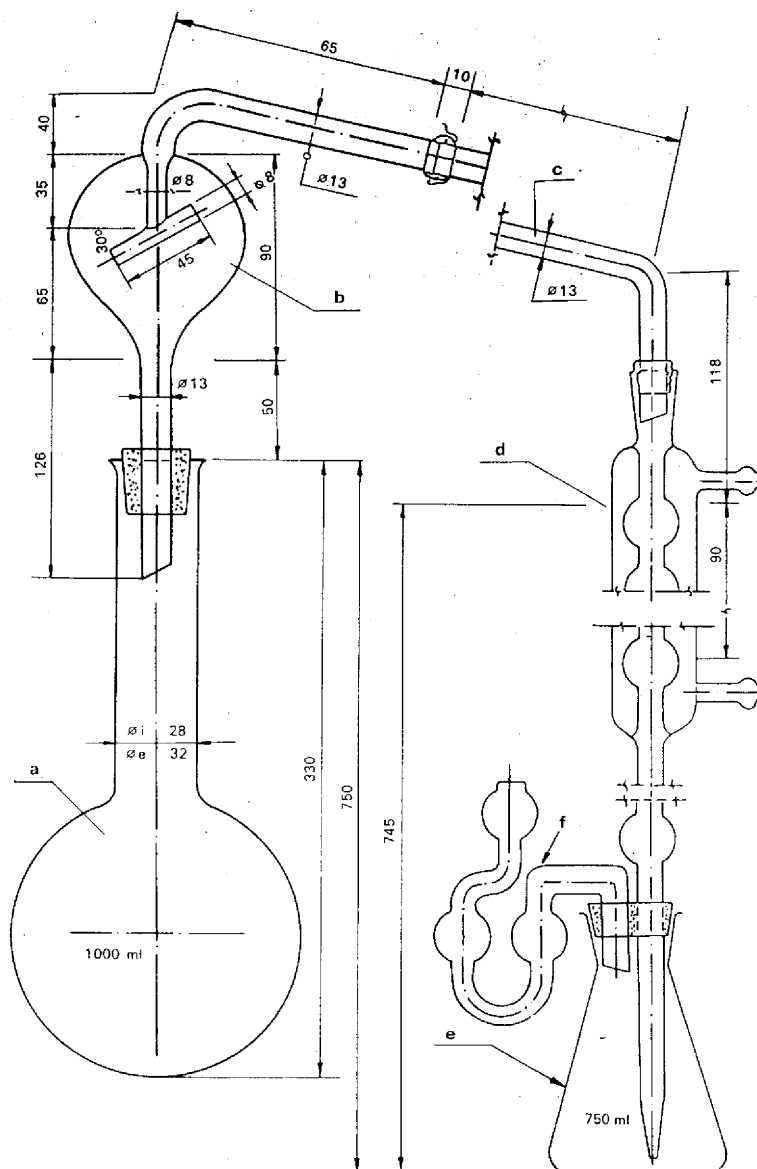

Key to Figure 5

- (a) A 750-ml (1 000 ml) round-bottomed, long-necked flask with a bell mouth.
- (b) Distillation tube with a splash head and a No 18 spherical joint at the issue.
- (c) Elbow tube with a No 18 spherical joint at the entrance, and a drip cone at the issue (a suitable rubber connection may be used instead of the spherical joint).
- (d) A six-bulb condenser with an extension tube mounted on a rubber bung holding a bubble trap.
- (e) A 750-ml receiving flask.
- (f) A bubble trap to prevent loss of ammonia.

The equipment is made of borosilicate glass.

Method 2.3

Determination of total nitrogen

Method 2.3.1

Determination of the total nitrogen in calcium cyanamide nitrate free**1. Scope**

This document defines the procedure for the determination of total nitrogen in nitrate free, calcium cyanamide.

2. Field of application

Exclusively to calcium cyanamide (nitrate free).

3. Principle

After Kjeldahl digestion, the ammoniacal nitrogen formed is displaced by sodium hydroxide, collected and estimated in a standard solution of sulphuric acid.

4. Reagents

Distilled or demineralised water, free from carbon dioxide and all nitrogenous compounds.

4.1. Dilute sulphuric acid ($d_{20} = 1,54$ g/ml): one volume of sulphuric acid ($d_{20} = 1,84$ g/ml) plus one volume of water

4.2. Potassium sulphate for analysis

4.3. Copper oxide (CuO): 0,3 to 0,4 g for each estimation, or an equivalent quantity of copper sulphate pentahydrate ($\text{CuSO}_4 \cdot 5\text{H}_2\text{O}$), from 0,95 to 1,25 g for each estimation

4.4. Sodium hydroxide solution, approximately 30 % NaOH ($d_{20} = 1,33$ g/ml), ammonia free

4.5. Sulphuric acid: 0,1 mol/l

4.6. Sodium or potassium hydroxide solution, carbonate free: 0,1 mol/l

} for variant a (see Method 2.1).

4.7. Sulphuric acid: 0,2 mol/l

4.8. Sodium or potassium hydroxide solution, carbonate free: 0,2 mol/l

} for variant b (see note 2, Method 2.1).

4.9. Sulphuric acid: 0,5 mol/l

4.10. Sodium or potassium hydroxide solution, carbonate free: 0,5 mol/l

} for variant c (see note 2, Method 2.1).

4.11. Indicator solutions**4.11.1. Mixed indicator**

Solution A: Dissolve 1 g of methyl red in 37 ml of 0,1 mol/l sodium hydroxide solution and make up to one litre with water.

Solution B: Dissolve 1 g of methylene blue in water and make up to one litre.

Mix one volume of A with two volumes of B.

This indicator is violet in acid solution, grey in neutral solution and green in alkaline solution. Use 0,5 ml (10 drops).

4.11.2. Methyl red indicator

Dissolve 0,1 g of methyl red in 50 ml of 95 % ethanol and make up to 100 ml with water. Filter if necessary. This indicator (four or five drops) may be used instead of the preceding one.

4.12. Anti-bump granules of pumice stone, washed in hydrochloric acid and calcined

4.13. Potassium thiocyanate for analysis

5. Apparatus

5.1. Distilling apparatus, see Method 2.1 'Determination of ammoniacal nitrogen'

5.2. A long-necked Kjeldahl flask of suitable capacity

5.3. Pipettes of 50, 100 and 200 ml

5.4. A 250-ml graduated flask

6. Preparation of the sample

See Method 1.

7. Procedure

7.1. Preparation of the solution for analysis

Weigh, to the nearest 0,001 g, 1 g of the sample and place it in the Kjeldahl flask. Add 50 ml of diluted sulphuric acid (4.1), 10 to 15 g of potassium sulphate (4.2), and the prescribed catalyst (4.3). Heat slowly to drive off the water, boil gently for two hours, allow to cool, and dilute with 100 to 150 ml of water. Cool again, transfer quantitatively the suspension to a graduated 250-ml flask, make up the volume with water, shake, and filter through a dry filter into a dry flask.

7.2. Analysis of the solution

With a pipette, transfer, according to the variant chosen (see Method 2.1), 50, 100 or 200 ml of the solution thus obtained, and distil the ammonia as described in Method 2.1, adding sufficient NaOH solution (4.4) to ensure a considerable excess.

7.3. Blank test

Carry out a blank test (omitting the sample) under the same conditions and refer to this in the calculation of the final result.

7.4. Control test

Before carrying out the analysis, check that the apparatus is working properly and that the correct application of the method is used, using an aliquot part of a standard solution of potassium thiocyanate (4.13), approximating to the concentration of nitrogen in the sample.

8. Expression of the result

Express the result as the percentage of nitrogen (N) contained in the fertiliser as received for analysis.

Variant a: $\% N = (50 - A) \times 0,7$

Variant b: $\% N = (50 - A) \times 0,7$

Variant c: $\% N = (35 - A) \times 0,875$

Method 2.3.2

Determination of total nitrogen in calcium cyanamide containing nitrates

1. Scope

This document defines the procedure for the determination of total nitrogen in calcium cyanamide.

2. Field of application

The method is applicable to calcium cyanamide containing nitrates.

3. Principle

The direct application of Kjeldahl's Method cannot be applied to calcium cyanamides containing nitrates. For this reason the nitrate nitrogen is reduced to ammonia with metallic iron and stannous chloride before Kjeldahl digestion.

4. Reagents

Distilled or demineralised water, free from carbon dioxide and all nitrogenous compounds.

4.1. Sulphuric acid ($d_{20} = 1,84$ g/ml)

4.2. Powdered iron reduced in hydrogen

4.3. Potassium sulphate, finely pulverised, for analysis

4.4. Sulphuric acid: 0,1 mol/l

4.5. Sodium or potassium hydroxide standard solution, carbonate free: 0,1 mol/l

} for variant a (see Method 2.1).

4.6. Sulphuric acid: 0,2 mol/l

4.7. Sodium or potassium hydroxide standard solution, carbonate free: 0,2 mol/l

} for variant b (see note 2, Method 2.1).

4.8. Sulphuric acid: 0,5 mol/l

4.9. Sodium or potassium hydroxide standard solution, carbonate free: 0,5 mol/l

} for variant c (see note 2, Method 2.1).

4.10. Indicator solutions

4.10.1. Mixed indicator

Solution A: Dissolve 1 g of methyl red in 37 ml of 0,1 mol/l sodium hydroxide solution and make up to one litre with water.

Solution B: Dissolve 1 g of methylene blue in water and make up to one litre.

Mix one volume of A with two volumes of B.

This indicator is violet in acid solution, grey in neutral solution and green in alkaline solution. Take 0,5 ml (10 drops) of this indicator solution.

4.10.2. Methyl red indicator

Dissolve 0,1 g of methyl red in 50 ml of 95 % ethanol, make up to 100 ml with water and filter if necessary. This indicator (four or five drops) may be used instead of the preceding one.

4.11. Solution of stannous chloride

Dissolve 120 g of $\text{SnCl}_2 \cdot 2\text{H}_2\text{O}$ in 400 ml of concentrated hydrochloric acid ($d_{20} = 1,18$ g/ml) and make up to one litre with water. The solution must be completely clear and prepared immediately before use. It is essential to check the reducing power of the stannous chloride.

Note

Dissolve 0,5 g of $\text{SnCl}_2 \cdot 2\text{H}_2\text{O}$ in 2 ml of concentrated hydrochloric acid ($d_{20} = 1,18$ g/ml) and make up to 50 ml with water. Then add 5 g of Rochelle salt (potassium sodium tartrate) and a sufficient quantity of sodium bicarbonate for analysis for the solution to show an alkaline reaction to a litmus paper test.

Titrate with 0,1 mol/l iodine solution in the presence of a starch solution as an indicator.

1 ml of iodine solution 0,1 mol/l corresponds to 0,01128 g of $\text{SnCl}_2 \cdot 2\text{H}_2\text{O}$.

At least 80 % of the total tin present in the solution thus prepared must be in a bivalent form. For the titration at least 35 ml of 0,1 mol/l iodine solution should be used.

4.12. Solution of sodium hydroxide containing about 30 % NaOH ($d_{20} = 1,33$ g/ml), ammonia free

4.13. *Standard nitrate-ammoniacal solution*

Weigh out 2,5 g of potassium nitrate for analysis and 10,16 g of ammonium sulphate for analysis and place them in a 250-ml graduated flask. Dissolve in water and make up to 250 ml. 1 ml of this solution contains 0,01 g of nitrogen.

4.14. Pumice stone anti-bump granules, washed in hydrochloric acid and calcined

5. **Apparatus**

See Method 2.3.1.

6. **Preparation of the sample**

See Method 1.

7. **Procedure**

7.1. *Preparation of the solution*

Weigh, to the nearest 0,001 g, 1 g of the sample and place it in the Kjeldahl flask. Add 0,5 g of powdered iron (4.2) and 50 ml of the stannous chloride solution (4.11), stir and leave standing for half an hour. During the time it is left standing, stir again after 10 and 20 minutes. Then add 10 g of potassium sulphate (4.3) and 30 ml of sulphuric acid (4.1). Boil and carry on the process for an hour after the appearance of white fumes. Leave to cool and dilute with 100 to 150 ml of water. Transfer the suspension quantitatively into a 250-ml graduated flask, cool and make up the volume with water, stir and filter through a dry filter into a dry container. Instead of then siphoning off the suspension in order to apply the variant a, b or c, used in Method 2.1, the ammoniacal nitrogen in this solution may also be distilled directly, after adding sufficient sodium hydroxide to ensure a large surplus (4.12).

7.2. *Analysis of the solution*

With a pipette, transfer, according to the variant a, b or c, used in Method 2.1, 50, 100 or 200 ml of the solution thus obtained. Distil the ammonia according to the process described in Method 2.1, taking care to add to the distillation flask sufficient sodium hydroxide solution (4.12) to ensure a large excess.

7.3. *Blank test*

Carry out a blank test (omitting the sample) under the same conditions and refer to this in the calculation of the final result.

7.4. *Control test*

Before carrying out the analysis, check that the apparatus is working properly and that the correct application of the method is used with a standard solution (4.13) containing quantities of ammoniacal and nitrate nitrogen comparable to the quantities of cyanamide and nitrate nitrogen contained in nitrated calcium cyanamide.

For this purpose place 20 ml of the standard solution (4.13) in the Kjeldahl flask.

Carry out the analysis according to the method described in 7.1 and 7.2.

8. **Expression of the result**

The result of the analysis must be expressed as the percentage of total nitrogen (N) contained in the fertiliser as received for analysis.

Variant a: % N = $(50 - A) \times 0,7$

Variant b: % N = $(50 - A) \times 0,7$

Variant c: % N = $(35 - A) \times 0,875$

Method 2.3.3

Determination of total nitrogen in urea**1. Scope**

This document defines the procedure for the determination of total nitrogen in urea.

2. Field of application

This method is applied exclusively to urea fertilisers which are nitrate free.

3. Principle

Urea is transformed quantitatively into ammonia by boiling in the presence of sulphuric acid. The ammonia thus obtained is distilled from an alkaline medium, the distillate being collected in an excess of standard sulphuric acid. The excess acid is titrated by means of a standard alkaline solution.

4. Reagents

Distilled or demineralised water, free from carbon dioxide and all nitrogenous compounds.

- 4.1. Sulphuric acid, concentrated ($d_{20} = 1,84$ g/ml)
- 4.2. Sodium hydroxide solution, approximately 30 % NaOH ($d_{20} = 1,33$ g/ml), ammonia free
- 4.3. Sulphuric acid: 0,1 mol/l
- 4.4. Sodium or potassium hydroxide solution, carbonate free: 0,1 mol/l
- 4.5. Sulphuric acid: 0,2 mol/l
- 4.6. Sodium or potassium hydroxide solution, carbonate free: 0,2 mol/l
- 4.7. Sulphuric acid: 0,5 mol/l
- 4.8. Sodium or potassium hydroxide solution, carbonate free: 0,5 mol/l
- 4.9. *Indicator solutions*
- 4.9.1. Mixed indicator
- 4.9.2. Methyl red indicator solution
- 4.10. Anti-bump granules of pumice stone, washed in hydrochloric acid and calcined
- 4.11. Urea for analysis

} for variant a (see Method 2.1).

} for variant b (see note 2, Method 2.1).

} for variant c (see note 2, Method 2.1).

Solution A: Dissolve 1 g of methyl red in 37 ml of 0,1 mol/l sodium hydroxide solution and make up to one litre with water.

Solution B: Dissolve 1 g of methylene blue in water and make up to one litre.

Mix one volume of A with two volumes of B.

This indicator is violet in acid solution, grey in neutral solution and green in alkaline solution. Use 0,5 ml (10 drops).

Dissolve 0,1 g of methyl red in 50 ml of 95 % ethanol and make up to 100 ml with water. Filter if necessary. This indicator (four or five drops) may be used instead of the preceding one.

5.1. Distillation apparatus, see Method 2.1 'Determination of ammoniacal nitrogen'

5.2. A 500-ml graduated flask

5.3. Pipettes of 25, 50 and 100 ml

6. Preparation of the sample

See Method 1.

7. Procedure**7.1. Preparation of the solution**

Weigh, to the nearest 0,001 g, 2,5 g of the prepared sample, place it in a 300-ml Kjeldahl flask and moisten with 20 ml water. Stir in 20 ml of concentrated sulphuric acid (4.1) and add a few glass beads to prevent bumping. To prevent splashing, place a long-stemmed glass funnel in the neck of the flask. Heat, slowly at first, then increase the heat until white fumes are observed (30 to 40 minutes).

Cool and dilute with 100 to 150 ml water. Quantitatively transfer to a 500-ml volumetric flask, discarding any sediment. Allow to cool to room temperature. Make up the volume with water, mix and, if necessary, filter through a dry filter into a dry receptacle.

7.2. Analysis of the solution

With a precision pipette, transfer 25, 50 or 100 ml of the solution thus obtained into the distillation flask, according to the variant chosen (see Method 2.1). Distil the ammonia as described in Method 2.1, adding sufficient NaOH ($d_{20} = 1,33$ g/ml) (4.2) to the distilling flask to ensure a considerable excess.

7.3. Blank test

Carry out a blank test (omitting the sample) under the same conditions and refer to this in the calculation of the final result.

7.4. Control test

Before carrying out the analysis, check that the apparatus is working properly and that the correct application of the Method is used, using an aliquot part of a freshly prepared solution of urea (4.11).

8. Expression of the result

Express the result as the percentage of nitrogen (N) contained in the fertiliser as received for analysis.

Variant a: % N = $(50 - A) \times 1,12$

Variant b: % N = $(50 - A) \times 1,12$

Variant c: % N = $(35 - A) \times 1,40$

Method 2.4**Determination of cyanamide nitrogen****1. Scope**

This document defines the procedure for the determination of cyanamide nitrogen.

2. Field of application

Calcium cyanamide and calcium cyanamide/nitrate mixtures.

3. Principle

Cyanamide nitrogen is precipitated as a silver complex and estimated in the precipitate by Kjeldahl's method.

4. Reagents

Distilled or demineralised water, free from carbon dioxide and all nitrogenous compounds.

- 4.1. Glacial acetic acid
- 4.2. Ammonia solution containing 10 % of ammonia gas by mass ($d_{20} = 0,96$ g/ml)
- 4.3. *Ammoniacal silver solution, according to Tollens*

Mix 500 ml of 10 % silver nitrate (AgNO_3) solution in water with 500 ml of 10 % ammonia (4.2).

Do not expose unnecessarily to light, heat or air. The solution normally keeps for years. As long as the solution remains clear, the reagent is of good quality.
- 4.4. Concentrated sulphuric acid ($d_{20} = 1,84$ g/ml)
- 4.5. Potassium sulphate for analysis
- 4.6. Copper oxide (CuO), 0,3 to 0,4 g for each estimation, or an equivalent quantity of copper sulphate pentahydrate ($\text{CuSO}_4 \cdot 5\text{H}_2\text{O}$) from 0,95 to 1,25 g for each estimation
- 4.7. Sodium hydroxide solution, approximately 30 % NaOH ($d_{20} = 1,33$ g/ml), ammonia free
- 4.8. Sulphuric acid: 0,1 mol/l
- 4.9. Sodium or potassium hydroxide solution: 0,1 mol/l
- 4.10. *Indicator solutions*
 - 4.10.1. Mixed indicator

Solution A: Dissolve 1 g of methyl red in 37 ml of 0,1 mol/l sodium hydroxide solution and make up to one litre with water.

Solution B: Dissolve 1 g of methylene blue in water and make up to one litre.

Mix one volume of A with two volumes of B.

This indicator is violet in acid solution, grey in neutral solution and green in alkaline solution. Use 0,5 ml (10 drops).
 - 4.10.2. Methyl red indicator solution

Dissolve 0,1 g of methyl red in 50 ml of 95 % ethanol and make up to 100 ml with water. Filter if necessary. This indicator (four to five drops) may be used instead of the preceding one.
- 4.11. Anti-bump granules of pumice stone, washed in hydrochloric acid and calcined
- 4.12. Potassium thiocyanate for analysis
5. **Apparatus**
 - 5.1. Distillation apparatus, see Method 2.1 'Determination of ammoniacal nitrogen'
 - 5.2. A 500-ml graduated flask (e.g. Stohmann)
 - 5.3. A long-necked Kjeldahl flask of suitable capacity (300 to 500 ml)
 - 5.4. A 50-ml pipette
 - 5.5. A rotary shaker (35 to 40 turns per minute)
6. **Preparation**

See Method 1.
7. **Procedure**
 - 7.1. *Safety precaution*

When using any ammoniacal silver solution safety goggles must be worn. As soon as a thin membrane forms on the surface of the liquid, an explosion may be produced by agitation and the greatest caution is essential.

7.2. *Preparation of the solution for analysis*

Weigh, to the nearest 0,001 g, 2,5 g of the sample and place it in a small glass mortar. Grind the sample three times with water, pouring off the water after each grinding into a 500-ml graduated Stohmann flask (5.2). Transfer quantitatively the sample into the 500-ml graduated Stohmann flask, washing the mortar, pestle and funnel with water. Make up with water to approximately 400 ml. Add 15 ml of acetic acid (4.1). Shake on the rotary shaker (5.5) for two hours.

Make up to 500 ml with water, mix and filter.

The analysis must be carried out as quickly as possible.

7.3. *Analysis of the solution*

Transfer 50 ml of the filtrate, into a 250-ml beaker.

Add ammonia solution (4.2) until slightly alkaline and add 30 ml of warm ammoniacal silver nitrate (4.3) in order to precipitate the yellow silver complex of the cyanamide.

Leave overnight, filter and wash the precipitate with cold water until it is completely free of ammonia.

Place the filter and the precipitate, still moist, in a Kjeldahl flask, add 10 to 15 g of potassium sulphate (4.5), the catalyst (4.6), in the prescribed proportion, then 50 ml of water and 25 ml of concentrated sulphuric acid (4.4).

Warm the flask slowly, while shaking it gently until the contents come to the boil. Increase the heat, boil until the contents of the flask become colourless or pale green.

Continue boiling for one hour, then leave to cool.

Transfer the liquid quantitatively from the Kjeldahl flask to the distilling flask, add a few anti-bump granules of pumice stone (4.11) and make up with water to a total volume of approximately 350 ml. Mix and cool.

Distil the ammonia according to Method 2.1, variant a, adding sufficient NaOH solution (4.7) to ensure the presence of a considerable excess.

7.4. *Blank test*

Carry out a blank test (omitting the sample) under the same conditions and refer to this in the calculation of the final result.

7.5. *Control test*

Before carrying out the analysis, check that the apparatus is working properly and that the correct application of the method is used using an aliquot part of a standard solution of potassium thiocyanate (4.12) corresponding to 0,05 g of nitrogen.

8. **Expression of the result**

Express the result as the percentage of cyanamide nitrogen contained in the fertiliser as received for analysis.

$$\% N = (50 - A) \times 0,56$$

Method 2.5

Spectrophotometric determination of biuret in urea

1. **Scope**

This document defines the procedure for the determination of biuret in urea.

2. **Field of application**

The method is applied exclusively to urea.

3. Principle

In an alkaline medium, in the presence of potassium sodium tartrate, biuret and bivalent copper from a violet cupric compound. The absorbance of the solution is measured at a wave length of about 546 nm (nanometer).

4. Reagents

Distilled or demineralised water, free from carbon dioxide and ammonia. The quality of this water is particularly important in this determination.

4.1. Methanol

4.2. Sulphuric acid solution, about 0,1 mol/l

4.3. Sodium hydroxide solution, about 0,1 mol/l

4.4. Alkaline solution of potassium sodium tartrate

In a graduated one-litre flask, dissolve 40 g of sodium hydroxide in 500 ml of water and leave to cool. Add 50 g of potassium sodium tartrate ($\text{NaKC}_4\text{H}_4\text{O}_6 \cdot 4\text{H}_2\text{O}$). Make up to the mark. Leave standing 24 hours before use.

4.5. Solution of copper sulphate

In a graduated one-litre flask, dissolve 15 g of copper sulphate pentahydrate ($\text{CuSO}_4 \cdot 5\text{H}_2\text{O}$) in 500 ml of water. Make up to the mark.

4.6. Freshly prepared biuret standard solution

In a 250-ml graduated flask, dissolve 0,250 g of pure biuret ⁽¹⁾ in water. Make up to 250 ml. 1 ml of this solution contains 0,001 g of biuret.

4.7. Indicator solution

In a graduated 100-ml flask, dissolve 0,1 g of methyl red in 50 ml of 95 % ethanol, make up to 100 ml with water. Filter if any insolubles remain.

5. Apparatus

5.1. Spectrometer or photometer with filters of a sensitivity and precision to permit measures of less than 0,5 % T to be reproduced ⁽²⁾.

5.2. Graduated flasks of 100, 250 and 1 000 ml

5.3. Graduated pipettes of 2, 5, 10, 20, 25 and 50 ml or a 25 ml burette, graduated to 0,05 ml

5.4. A 250-ml beaker

6. Preparation of the sample

See Method 1.

7. Procedure

7.1. Preparation of the calibration curve

Transfer 0, 2, 5, 10, 20, 25 and 50 ml of aliquots of biuret standard solution (4.6) into a series of seven graduated 100-ml flasks. Make up the volumes to about 50 ml with water, add one drop of indicator (4.7) and neutralise, if necessary, with sulphuric acid 0,1 mol/l (4.2). Stir in 20 ml of the alkaline tartrate solution (4.4) then 20 ml of the copper sulphate solution (4.5).

Note

These solutions (4.4 and 4.5) must be measured in with two precision burettes or better still with pipettes.

Make up to 100 ml with distilled water, mix and leave standing for 15 minutes at 30 (\pm 2) °C.

⁽¹⁾ Biuret can be purified beforehand by washing with an ammoniacal solution (10 %), then with acetone and drying in a vacuum.

⁽²⁾ See point 9 'Appendix'.

With the '0' biuret standard solution as reference, measure the absorbance of each solution at a wavelength of about 546 nm using cells of a suitable path length.

Plot the calibration curve, using the absorbances as the ordinates and the corresponding quantities of biuret, in milligrams, as the abscissae.

7.2. Preparation of the solution to be analysed

Weigh, to the nearest 0,001 g, 10 g of the prepared sample; dissolve in about 150 ml of water in a 250-ml graduated flask, and make up to the mark. Filter if necessary.

Remark 1

If the sample for analysis contains more than 0,015 g of ammoniacal nitrogen, dissolve it, in a 250-ml beaker, in 50 ml of methanol (4.1). Reduce by evaporation to a volume of about 25 ml. Transfer quantitatively to a graduated 250-ml flask. Make up to the mark with water. Filter, if necessary, through a dry fluted filter into a dry container.

Remark 2

Elimination of the opalescence: if any colloid substance is present, difficulties may arise during filtering. The solution intended for analysis is in that case prepared as follows: dissolve the sample for analysis in 150 ml of water, add 2 ml of 1 mol/l hydrochloric acid, and filter the solution through two flat very fine filters into a graduated 250-ml flask. Wash the filters with water and make up to volume. Continue the process according to the method described in 7.3 'Determination'.

7.3. Determination

According to the presumed biuret content, transfer 25 or 50 ml from the solution mentioned in 7.2 with a pipette, place this quantity in a 100-ml graduated flask and neutralise if necessary with a 0,1 mol/l reagent (4.2 or 4.3) as required, using methyl red as an indicator and add, with the same accuracy as that used when drawing up a calibration curve, 20 ml of the alkaline solution of potassium sodium tartrate (4.4) and 20 ml of the copper solution (4.5). Make up to volume, mix thoroughly and leave standing for 15 minutes at 30 (\pm 2) °C.

Then carry out the photometric measurements and calculate the quantity of biuret present in the urea.

8. Expression of the result

$$\% \text{ biuret} = \frac{C \times 2,5}{V}$$

Where

'C' is the mass, in milligrams, of biuret, read from the calibration graph,

'V' the volume of the aliquot:

9. Appendix

'J₀' being the intensity of the beam of monochromatic rays (of a determinate wavelength) before it passes through a transparent body, and 'J' being the intensity of this beam after the passage, then:

— factor of transmission:	$T = \frac{J}{J_0}$
— opacity:	$O = \frac{J_0}{J}$
— absorbance:	$E = \log O$
— absorbance per unit of optical run:	$k = \frac{E}{S}$
— coefficient of specific absorbance:	$K = \frac{E}{C \times S}$

where

s = thickness of the layer in centimetres.

c = concentration in milligrams per litre.

k = specific factor for each substance in the Lambert-Beer law.

Methods 2.6

Determination of different forms of nitrogen in the same sample

Method 2.6.1

Determination of different forms of nitrogen in the same sample in fertilisers containing nitrogen as nitric, ammoniacal, urea and cyanamide nitrogen**1. Scope**

This document defines the procedure for the determination of any one form of nitrogen in the presence of any other form.

2. Field of application

Any fertiliser provided for in Annex I containing nitrogen in various forms.

3. Principle**3.1. Total soluble and insoluble nitrogen**

According to the list of standard fertilisers (Annex I), this determination is applicable to products containing calcium cyanamide.

3.1.1. In the absence of nitrates, the test sample is mineralised by direct Kjeldahl digestion

3.1.2. In the presence of nitrates, the test sample is mineralised by Kjeldahl digestion after reduction with the aid of metallic iron and stannous chloride

In both cases, the ammonia is determined according to Method 2.1.

Note

If analysis shows an insoluble nitrogen content of more than 0,5 %, one concludes that the fertiliser contains other forms of insoluble nitrogen not included in the list in Annex I.

3.2. Forms of soluble nitrogen

The following are determined from different aliquots taken from the same solution of the sample:

3.2.1. total soluble nitrogen:

3.2.1.1. in the absence of nitrates, by direct Kjeldahl digestion,

3.2.1.2. in the presence of nitrates, by Kjeldahl digestion on an aliquot part taken from the solution after reduction according to Ulsch, the ammonia being determined in both cases, as described in Method 2.1;

3.2.2. total soluble nitrogen with the exception of nitrate nitrogen by Kjeldahl digestion after elimination in an acid medium of nitrate nitrogen with ferrous sulphate, the ammonia being determined as described in Method 2.1;

3.2.3. nitrate nitrogen by difference:

3.2.3.1. in the absence of calcium cyanamide, between 3.2.1.2 and 3.2.2 or between total soluble nitrogen (3.2.1.2) and the sum of ammoniacal nitrogen and ureic organic nitrogen (3.2.4 + 3.2.5),

3.2.3.2. in the presence of calcium cyanamide, between 3.2.1.2 and 3.2.2 or between 3.2.1.2 and the sum of 3.2.4 + 3.2.5 + 3.2.6;

3.2.4. ammoniacal nitrogen:

3.2.4.1. solely in the presence of ammoniacal nitrogen and ammoniacal plus nitrate nitrogen, by applying Method 1,

3.2.4.2. in the presence of urea nitrogen and/or cyanamide nitrogen by cold distillation after making slightly alkaline, the ammonia being absorbed in a standard solution of sulphuric acid and determined as described in Method 2.1;

- 3.2.5. urea nitrogen:
- 3.2.5.1. by conversion using urease, into ammonia which is titrated with a standard solution of hydrochloric acid,
or
- 3.2.5.2. by gravimetry with xanthidol: the co-precipitated biuret can be counted with urea nitrogen without great error, its content remaining generally low in absolute value in compound fertilisers,
or
- 3.2.5.3. by difference according to the following table:

Case	Nitrate nitrogen	Ammoniacal nitrogen	Cyanamidic nitrogen	Difference
1	Absent	Present	Present	(3.2.1.1) — (3.2.4.2 + 3.2.6)
2	Present	Present	Present	(3.2.2) — (3.2.4.2 + 3.2.6)
3	Absent	Present	Absent	(3.2.1.1) — (3.2.4.2)
4	Present	Present	Absent	(3.2.2) — (3.2.4.2)

- 3.2.6. cyanamide nitrogen, by precipitation as a silver compound, the nitrogen being estimated in the precipitate by the Kjeldahl method

4. Reagents

Distilled or demineralised water.

- 4.1. Potassium sulphate for analysis
- 4.2. Iron powder, reduced with hydrogen (the prescribed quantity of iron must be able to reduce at least 50 mg of nitrate nitrogen)
- 4.3. Potassium thiocyanate for analysis
- 4.4. Potassium nitrate for analysis
- 4.5. Ammonium sulphate for analysis
- 4.6. Urea for analysis
- 4.7. Dilute sulphuric acid 1: 1 by volume: one volume of sulphuric acid ($d_{20} = 1,84$ g/ml) in one volume of water
- 4.8. Standard solution of sulphuric acid: 0,2 mol/l
- 4.9. Concentrated sodium hydroxide solution. Aqueous solution at about 30 % (W/V) of NaOH, free from ammonia
- 4.10. Standard solution of sodium or potassium hydroxide: 0,2 mol/l, free from carbonates
- 4.11. *Stannous chloride solution*

Dissolve 120 g of $\text{SnCl}_2 \cdot 2\text{H}_2\text{O}$ in 400 ml of concentrated hydrochloric acid ($d_{20} = 1,18$ g/ml) and make up to one litre with water. The solution must be perfectly clear and prepared immediately before its use.

Note

It is essential to check the reducing power of stannous chloride: dissolve 0,5 g of $\text{SnCl}_2 \cdot 2\text{H}_2\text{O}$ in 2 ml of concentrated hydrochloric acid ($d_{20} = 1,18$ g/ml) and make up to 50 ml with water. Then add 5 g of Rochelle salt (potassium sodium tartrate), then a sufficient quantity of sodium bicarbonate for the solution to be alkaline to litmus paper.

Titrate with a 0,1 mol/l iodine solution in the presence of a starch solution as an indicator.

1 ml of 0,1 mol/l iodine solution corresponds to 0,01128 g of $\text{SnCl}_2 \cdot 2\text{H}_2\text{O}$.

At least 80 % of the total tin present in the solution thus prepared must be in bivalent form. For the titration at least 35 ml of 0,1 mol/l iodine solution must therefore be used.

- 4.12. Sulphuric acid ($d_{20} = 1,84$ g/ml)
- 4.13. Dilute hydrochloric acid: one volume of hydrochloric acid ($d_{20} = 1,18$ g/ml) plus one volume of water
- 4.14. Acetic acid: 96 to 100 %
- 4.15. Sulphuric acid solution containing about 30 % of H_2SO_4 (W/V)
- 4.16. Ferrous sulphate: crystalline, $FeSO_4 \cdot 7H_2O$
- 4.17. Standard sulphuric acid solution: 0,1 mol/l
- 4.18. Octyl alcohol
- 4.19. Saturated solution of potassium carbonate
- 4.20. Standard solution of sodium or potassium hydroxide: 0,1 mol/l (free from carbonates)
- 4.21. Saturated solution of barium hydroxide
- 4.22. Sodium carbonate solution: at 10 % (W/V)
- 4.23. Hydrochloric acid: 2 mol/l
- 4.24. Standard solution of hydrochloric acid: 0,1 mol/l
- 4.25. *Urease solution*
Suspend 0,5 g of active urease in 100 ml of distilled water. Using hydrochloric acid 0,1 mol/l (4.24), adjust the pH to 5,4, measured by a pH meter.
- 4.26. *Xanthidrol*
Solution at 5 % in ethanol or methanol (4.31) (do not use products giving a high proportion of insoluble matter). The solution may be kept for three months in a well-stoppered bottle, away from the light.
- 4.27. Copper oxide (CuO): 0,3 to 0,4 g per estimation or an equivalent quantity of copper sulphate pentahydrate ($CuSO_4 \cdot 5H_2O$) of 0,95 to 1,25 g per estimation
- 4.28. Anti-bump granules washed in hydrochloric acid and calcined
- 4.29. *Indicator solutions*
- 4.29.1. Solution A: Dissolve 1 g of methyl red in 37 ml of sodium hydroxide solution 0,1 mol/l and make up to one litre with water.
Solution B: Dissolve 1 g of methylene blue in water and make up to one litre.
Mix one volume of A with two volumes of B.
This indicator is violet in acid solution, grey in neutral solution and green in alkaline solution. Use 0,5 ml (10 drops) of this indicator solution.
- 4.29.2. Methyl red indicator solution
Dissolve 0,1 g of methyl red in 50 ml of 95 % ethanol. Make up to 100 ml with water and filter if necessary. This indicator (four or five drops) can be used instead of the previous one.
- 4.30. *Indicator papers*
Litmus bromothymol blue (or other papers sensitive to pH 6 to 8).
- 4.31. Ethanol or methanol: solution 95 %
5. **Apparatus**
- 5.1. *Distillation apparatus*
See Method 2.1.

5.2. *Apparatus for the estimation of ammoniacal nitrogen according to analytical technique 7.2.5.3 (see Figure 6)*

The apparatus is made up of a specially shaped receptacle with a ground glass neck, with a side neck, a connecting tube with a splash head and a perpendicular tube for the introduction of air. The tubes can be connected to the receptacle by means of a simple perforated rubber bung. It is important to give a suitable shape to the end of the tubes introducing air, since the bubbles of gas must be perfectly distributed throughout the solutions contained in the receptacle and the absorber. The best arrangement consists of small mushroom-shaped pieces with an external diameter of 20 mm and six openings of 1 mm around the periphery.

5.3. *Apparatus for the estimation of urea nitrogen according to the urease technique (7.2.6.1)*

It consists of a 300 ml Erlenmeyer flask, with a separating funnel and a small absorber (see Figure 7).

5.4. Rotary shaker (35 to 40 turns per minute)

5.5. A pH meter

5.6. Adjustable oven

5.7. *Glassware:*

pipettes of 2, 5, 10, 20, 25, 50 and 100 ml,

long-necked Kjeldahl flasks of 300 and 500 ml,

graduated flasks of 100, 250, 500 and 1 000 ml,

crucibles of sintered glass, pore diameter, 5 to 15 μ ,

mortars.

6. **Preparation of the sample**

See Method 1.

7. **Analytical technique**

7.1. *Total soluble and insoluble nitrogen*

7.1.1. In the absence of nitrates

7.1.1.1. Digestion

Weigh out, to an accuracy of 0,001 g, a quantity of the sample containing 100 mg of nitrogen at the most. Place it in the flask of the distillation apparatus (5.1). Add 10 to 15 g of potassium sulphate (4.1), the catalyst (4.27), and a few anti-bump granules (4.28). Then add 50 ml of dilute sulphuric acid (4.7), and mix thoroughly. First heat gently mixing from time to time, until foam no longer forms. Then heat so that the liquid boils regularly and keep it boiling for one hour after the solution has become clear, preventing any organic matter from sticking to the sides of the flask. Allow to cool. Carefully add about 350 ml of water, with mixing. Ensure that the dissolution is as complete as possible. Allow to cool and connect the flask to the distillation apparatus (5.1).

7.1.1.2. Distillation of ammonia

Transfer with a precision pipette, into the receiver of the apparatus, 50 ml of a standard solution of sulphuric acid 0,2 mol/l (4.8). Add the indicator (4.29.1 or 4.29.2). Ensure that the tip of the condenser is at least 1 cm below the level of the solution.

Taking the necessary precautions to avoid any loss of ammonia, carefully add to the distillation flasks enough of the concentrated sodium hydroxide solution (4.9) to make the liquid strongly alkaline (120 ml is generally sufficient; check by adding a few drops of phenolphthalein. At the end of the distillation the solution in the flask must still be clearly alkaline). Adjust the heating of the flask so as to distil 150 ml in half an hour. Test with indicator paper (4.30) that the distillation has been completed. If it has not, distil a further 50 ml and repeat the test until the supplementary distillate reacts neutrally to the indicator paper (4.30). Then lower the receiver, distil a few millilitres more and rinse the tip of the condenser. Titrate the excess of acid with a standard solution of potassium or sodium hydroxide 0,2 mol/l (4.10) until the indicator changes colour.

7.1.1.3. Blank test

Carry out a blank test (omitting the sample) under the same conditions and take account of it when calculating the final result.

7.1.1.4. Expression of the result

$$\% N = \frac{(a - A) \times 0,28}{M}$$

where

a = ml of standard solution of sodium or potassium hydroxide 0,2 mol/l, used for the blank, carried out by pipetting into the receiver of the apparatus (5.1), 50 ml of standard solution of sulphuric acid 0,2 mol/l (4.8),

A = ml of standard solution of sodium or potassium hydroxide 0,2 mol/l, used for the analysis,

M = mass of the test sample, in grams.

7.1.2. In the presence of nitrate

7.1.2.1. Test sample

Mass out, to an accuracy of 0,001 g, a quantity of the sample containing not more than 40 mg of nitrate nitrogen.

7.1.2.2. Reduction of the nitrate

Mix the test sample in a small mortar with 50 ml of water. Transfer with the minimum amount of distilled water into a 500-ml Kjeldahl flask. Add 5 g of reduced iron (4.2) and 50 ml of stannous chloride solution (4.11). Shake and leave it to stand for half an hour. During the time it is standing, stir again after 10 and 20 minutes.

7.1.2.3. Kjeldahl digestion

Add 30 ml of sulphuric acid (4.12), 5 g of potassium sulphate (4.1), the prescribed quantity of catalyst (4.27) and some anti-bump granules (4.28). Heat gently with the flask slightly tilted. Increase the heat slowly and shake the solution frequently to keep the mixture suspended: the liquid darkens and then clears with the formation of a yellow-green anhydrous iron sulphate suspension. Then continue heating for one hour after obtaining a clear solution, maintaining it at simmering point. Leave to cool. Cautiously take the contents of the flask up in a little water and add little by little 100 ml of water. Mix and transfer the contents of the flask into a 500-ml graduated flask. Make up the volume with water. Mix. Filter through a dry filter into a dry receptacle.

7.1.2.4. Analysis of the solution

Transfer by pipette, into the flask of the distillation apparatus (5.1), an aliquot containing 100 mg of nitrogen at the most. Dilute to about 350 ml with distilled water, add a few anti-bump granules (4.28), connect the flask to the distillation apparatus and continue the estimation as described in 7.1.1.2.

7.1.2.5. Blank test

See 7.1.1.3.

7.1.2.6. Expression of the result

$$\% N = \frac{(a - A) \times 0,28}{M}$$

where

a = ml of standard solution of sodium or potassium hydroxide 0,2 mol/l, used for the blank, carried out by pipetting into the receiver of the apparatus (5.1), 50 ml of standard solution of sulphuric acid 0,2 mol/l (4.8),

A = ml of standard solution of sodium or potassium hydroxide 0,2 mol/l, used for the analysis,

M = mass of the sample, expressed in grams, present in the aliquot part taken in 7.1.2.4.

7.2. *Forms of soluble nitrogen*

7.2.1. Preparation of the solution to be analysed

Mass out, to an accuracy of 1 mg, 10 g of the sample and place it in a 500-ml graduated flask.

7.2.1.1. In the case of fertilisers not containing cyanamide nitrogen

Add to the flask 50 ml of water and then 20 ml of dilute hydrochloric acid (4.13). Shake and leave it to stand until the evolution of carbon dioxide ceases. Then add 400 ml of water and shake for half an hour on the rotary shaker (5.4). Make up to the volume with water, mix and filter through a dry filter into a dry receptacle.

7.2.1.2. In the case of fertilisers containing cyanamide nitrogen

Add to the flask 400 ml of water and a few drops of methyl red (4.29.2). If necessary make the solution acid by using acetic acid (4.14). Add 15 ml of acetic acid (4.14). Shake on the rotary shaker for two hours (5.4). If necessary, reacidify the solution during the operation, using acetic acid (4.14). Make up to the volume with water, mix, filter immediately through a dry filter into a dry receptacle and immediately estimate the cyanamide nitrogen.

In both cases, estimate the various soluble forms of nitrogen the same day the solution is made up, starting with the cyanamide nitrogen and urea nitrogen if they are present.

7.2.2. Total soluble nitrogen

7.2.2.1. In the absence of nitrate

Pipette into a 300-ml Kjeldahl flask, an aliquot of the filtrate (7.2.1.1 or 7.2.1.2), containing 100 mg of nitrogen at the most. Add 15 ml of concentrated sulphuric acid (4.12), 0,4 g of copper oxide or 1,25 g of copper sulphate (4.27) and a few anti-bump granules (4.28). First heat gently to begin the digestion and then at a higher temperature until the liquid become colourless or slightly greenish and white fumes are clearly apparent. After cooling, quantitatively transfer the solution into the distillation flask, dilute to about 500 ml with water, and add a few anti-bump granules (4.28). Connect the flask to the distillation apparatus (5.1) and continue the determination as described in 7.1.1.2.

7.2.2.2. In the presence of nitrate

Transfer with a precision pipette into a 500-ml Erlenmeyer, an aliquot of the filtrate (7.2.1.1 or 7.2.1.2) containing not more than 40 mg of nitrate nitrogen. At this stage of the analysis the total quantity of nitrogen is not important. Add 10 ml of sulphuric acid at 30 % (4.15), 5 g of reduced iron (4.2), and immediately cover the Erlenmeyer with a watch glass. Heat gently until the reaction is steady but not vigorous. At this juncture stop the heating and allow the flask to stand for at least three hours at ambient temperature. With water, quantitatively transfer the liquid into a 250-ml graduated flask, leaving behind the undissolved iron — make up to the mark with the water. Mix thoroughly, and transfer by precision pipette into a 300-ml Kjeldahl flask, an aliquot containing 100 mg of nitrogen at the most. Add 15 ml of concentrated sulphuric acid (4.12), 0,4 g of copper oxide or 1,25 g of copper sulphate (4.27) and some anti-bump granules (4.28). First heat gently to begin the digestion and then at a higher temperature until the liquid becomes colourless or slightly greenish and white fumes are clearly apparent. After cooling, quantitatively transfer the solution into the distillation flask, dilute to approximately 500 ml with water and add some anti-bump granules (4.28). Connect the flask to the distillation apparatus (5.1) and continue the determination as described in 7.1.1.2.

7.2.2.3. Blank test

See 7.1.1.3.

7.2.2.4. Expression of the result

$$\% N = \frac{(a - A) \times 0,28}{M}$$

where

a = ml of standard solution of sodium or potassium hydroxide 0,2 mol/l, used for the blank, carried out by pipetting into the receiver of the apparatus (5.1), 50 ml of standard solution of sulphuric acid 0,2 mol/l (4.8),

A = ml of standard solution of sodium or potassium hydroxide 0,2 mol/l, used for the analysis,

M = mass of the sample, expressed in grams, present in the aliquot part taken in 7.2.2.1 or 7.2.2.2.

7.2.3. Total soluble nitrogen with the exception of nitrate nitrogen

Transfer with a precision pipette into a 300-ml Kjeldahl flask, an aliquot sample of the filtrate (7.2.1.1 or 7.2.1.2) containing not more than 50 mg of nitrogen to be determined. Dilute to 100 ml with water, add 5 g of ferrous sulphate (4.16), 20 ml of concentrated sulphuric acid (4.12) and some anti-bump granules (4.28). First heat gently and then increase the heat until white fumes appear. Continue the digestion for 15 minutes. Stop the heating, introduce copper oxide (4.27) as a catalyst and keep it at a temperature such that white fumes are emitted for a further 10 to 15 minutes. After cooling, quantitatively transfer the contents to the Kjeldahl flask into the distillation flask of the apparatus (5.1). Dilute to approximately 500 ml with water and add a few anti-bump granules (4.28). Connect the flask to the distillation apparatus and continue the determination as described in 7.1.1.2.

7.2.3.1. Blank test

See 7.1.1.3.

7.2.3.2. Expression of the result

$$\% \text{ N} = \frac{(a - A) \times 0,28}{M}$$

where

a = ml of standard solution of sodium or potassium hydroxide 0,2 mol/l, used for the blank, carried out by pipetting into the receiver of the apparatus (5.1), 50 ml of standard solution of sulphuric acid 0,2 mol/l (4.8),

A = ml of standard solution of sodium or potassium hydroxide 0,2 mol/l, used for the analysis,

M = mass of the sample, expressed in grams, present in the aliquot part taken for the estimation.

7.2.4. Nitrate nitrogen

7.2.4.1. In the absence of calcium cyanamide

Is obtained by the difference between the results obtained in 7.2.2.4 and 7.2.3.2 and/or the result obtained in 7.2.2.4 and the sum of the results obtained in (7.2.5.2 or 7.2.5.5) and (7.2.6.3 or 7.2.6.5 or 7.2.6.6).

7.2.4.2. In the presence of calcium cyanamide

Is obtained by the difference between the results obtained in 7.2.2.4 and 7.2.3.2 and between the result obtained in 7.2.2.4 and the sum of the results obtained in (7.2.5.5), (7.2.6.3 or 7.2.6.5 or 7.2.6.6) and (7.2.7).

7.2.5. Ammoniacal nitrogen

7.2.5.1. Solely in the presence of ammoniacal nitrogen and ammoniacal plus nitrate nitrogen

Transfer with a precision pipette into the flask of the distillation apparatus (5.1), an aliquot sample of the filtrate (7.2.1.1) containing 100 mg of ammoniacal nitrogen at the most. Add water to obtain a total volume of about 350 ml and some anti-bump granules (4.28) to facilitate boiling. Connect the flask to the distillation apparatus, add 20 ml of sodium hydroxide solution (4.9) and distil as described in 7.1.1.2.

7.2.5.2. Expression of the result

$$\% \text{ N (ammoniacal)} = \frac{(a - A) \times 0,28}{M}$$

where

a = ml of standard solution of sodium or potassium hydroxide 0,2 mol/l, used for the blank, carried out by pipetting into the receiver of the apparatus (5.1), 50 ml of standard solution of sulphuric acid 0,2 mol/l (4.8),

A = ml of standard solution of sodium or potassium hydroxide 0,2 mol/l, used for the analysis,

M = mass of the sample, expressed in grams, present in the aliquot part taken for the estimation.

7.2.5.3. In the presence of urea and/or cyanamide nitrogen

Transfer with a precision pipette, into the dry flask of the apparatus (5.2), an aliquot sample of the filtrate (7.2.1.1 or 7.2.1.2) containing 20 mg of ammoniacal nitrogen at the most. Then assemble the apparatus. Pipette, into the 300-ml Erlenmeyer, 50 ml of the standard sulphuric acid solution 0,1 mol/l (4.17) and enough distilled water for the level of the liquid to be approximately 5 cm above the opening of the delivery tube. Introduce, through the side neck of the reaction flask, distilled water so as to make up the volume to about 50 ml. Mix. To avoid foaming during aeration, add a few drops of octyl alcohol (4.18). Then make the solution alkaline by using 50 ml of saturated potassium carbonate solution (4.19) and immediately begin to expel the ammonia thus liberated from the cold suspension. The strong current of air necessary to that end (flow of approximately three litres per minute) is purified beforehand by passing it through washing flasks containing dilute sulphuric acid and dilute sodium hydroxide. Instead of using pressurised air, it is also possible to work in a vacuum (water pump) provided that the inflow tube is connected in a sufficiently airtight manner to the receptacle used to recover the ammonia. The elimination of the ammonia is generally complete after three hours. It is nevertheless wise to make sure of that by changing the receiving flask. When the operation is finished, separate the flask from the apparatus, rinse the tip of the tube and the sides of the flask with a little distilled water. Titrate the excess of acid with a standard solution of sodium hydroxide 0,1 mol/l (4.20) until the indicator turns grey (4.29.1).

7.2.5.4. Blank test

See 7.1.1.3.

7.2.5.5. Expression of the result

$$\% \text{ N (ammoniacal)} = \frac{(a - A) \times 0,14}{M}$$

where

a = ml of standard solution of sodium or potassium hydroxide 0,1 mol/l, used for the blank, carried out by pipetting into the 300-ml Erlenmeyer of the apparatus (5.2), 50 ml of standard solution of sulphuric acid 0,1 mol/l (4.17),

A = ml of standard solution of sodium or potassium hydroxide 0,1 mol/l, used for the analysis,

M = mass of the sample, expressed in grams, present in the aliquot part taken for the analysis.

7.2.6. Urea nitrogen

7.2.6.1. Urease method

Transfer with a precision pipette, into a 500-ml graduated flask, an aliquot of the filtrate (7.2.1.1 or 7.2.1.2) containing not more than 250 mg of urea nitrogen. To precipitate the phosphates add some saturated barium hydroxide solution (4.21) until no further precipitation occurs. Then eliminate the excess of barium ions (and any dissolved calcium ions) with the aid of the sodium carbonate solution at 10 % (4.22).

Leave it to settle and check whether total precipitation has occurred. Make up to the mark, mix and filter through a pleated filter. Pipette 50 ml of the filtrate into the 300-ml Erlenmeyer of the apparatus (5.3). Acidify the filtrate with hydrochloric acid 2 mol/l (4.23) until a pH of 3,0 measured by the pH meter is obtained (5.5). Then raise the pH to 5,4 with sodium hydroxide 0,1 mol/l (4.20).

To avoid losses of ammonia during decomposition by the urease, close the Erlenmeyer with a stopper provided with a separating funnel and a small bubble trap containing exactly 2 ml of a standard solution of hydrochloric acid 0,1 mol/l (4.24). Introduce through the separating funnel 20 ml of urease solution (4.25), and leave it to stand for one hour at 20 to 25 °C. Then pipette 25 ml of the standard solution of hydrochloric acid 0,1 mol/l (4.24) into the separating funnel, allow it to run through into the solution and then rinse with a little water. In the same way quantitatively transfer the contents of the protective receptacle into the solution contained in the Erlenmeyer. Titrate the excess of acid with the standard solution of sodium hydroxide 0,1 mol/l (4.20), until a pH of 5,4 is obtained, measured by the pH meter.

7.2.6.2. Blank test

See 7.1.1.3.

7.2.6.3. Expression of the result

$$\% \text{ N (urea)} = \frac{(a - A) \times 0,14}{M}$$

where

a = ml of standard solution of sodium or potassium hydroxide 0,1 mol/l, used for the blank, carried out exactly in the same conditions as the analysis,

A = ml of standard solution of sodium or potassium hydroxide 0,1 mol/l, used for the analysis,

M = mass of the sample, expressed in grams, present in the aliquot part taken for the analysis.

Remark

- (1) After precipitation by the solutions of barium hydroxide and sodium carbonate, make up to the mark, filter and neutralise as rapidly as possible.
- (2) The titration test may also be carried out with the indicator (4.29.2), but the end point is then more difficult to observe.

7.2.6.4. Gravimetric method with xanthidrol

Transfer with a precision pipette, into a 250-ml beaker, an aliquot of the filtrate (7.2.1.1 or 7.2.1.2) containing not more than 20 mg of urea. Add 40 ml of acetic acid (4.14). Stir with a glass rod for one minute, leave any precipitate to settle for five minutes. Filter on a flat bed into a 100-ml beaker, wash with several millilitres of acetic acid (4.14), then add to the filtrate drop by drop, 10 ml of xanthidrol (4.26), stirring continuously with a glass rod. Leave it to settle until the precipitate appears, at that juncture, stir again for one or two minutes. Leave it to stand for one and a half hours. Filter through a glass filtering crucible, which has been previously dried and weighed, pressing it down slightly; wash three times with 5 ml of ethanol (4.31) without trying to eliminate all the acetic acid. Place it in the oven and keep it at a temperature of 130 °C for an hour (do not go above 145 °C). Leave it to cool in a desiccator and weigh.

7.2.6.5. Expression of the result

$$\% \text{ urea N} + \text{biuret} = \frac{6,67 \times m_1}{M_2}$$

where

m₁ = mass of the precipitate obtained, in grams,

M₂ = mass of the sample, expressed in grams, present in the aliquot part taken for the estimation.

Correct for a blank. Biuret may, generally speaking, be measured with the urea nitrogen without any great error, since its content remains small in absolute value in compound fertilisers.

7.2.6.6. Method by difference

Urea nitrogen may also be calculated according to the following table:

Case	Nitrate N	Ammoniacal N	Cyanamide N	Urea N
1	Absent	Present	Present	(7.2.2.4) — (7.2.5.5 + 7.2.7)
2	Present	Present	Present	(7.2.3.2) — (7.2.5.5 + 7.2.7)
3	Absent	Present	Absent	(7.2.2.4) — (7.2.5.5)
4	Present	Present	Absent	(7.2.3.2) — (7.2.5.5)

7.2.7. Cyanamide nitrogen

Take one aliquot part of the filtrate (7.2.1.2), containing 10 to 30 mg of cyanamide nitrogen and place it in a 250-ml beaker. Continue the analysis according to Method 2.4.

8. **Verification of the results**

- 8.1. In certain cases, a difference may be found between the total nitrogen obtained directly from a weighed out sample (7.1) and total soluble nitrogen (7.2.2). Nevertheless, the difference should not be greater than 0,5 %. If this is not the case, the fertiliser contains forms of insoluble nitrogen not contained in the list in Annex I.
- 8.2. Before each analysis, check that the apparatus is working properly and that the correct application of the method is used, with a standard solution including the various forms of nitrogen in proportions similar to those of the test sample. This standard solution is prepared from standard solutions of potassium thiocyanate (4.3), potassium nitrate (4.4), ammonium sulphate (4.5) and urea (4.6).

Figure 6

Apparatus for the estimation of ammoniacal nitrogen (7.2.5.3)

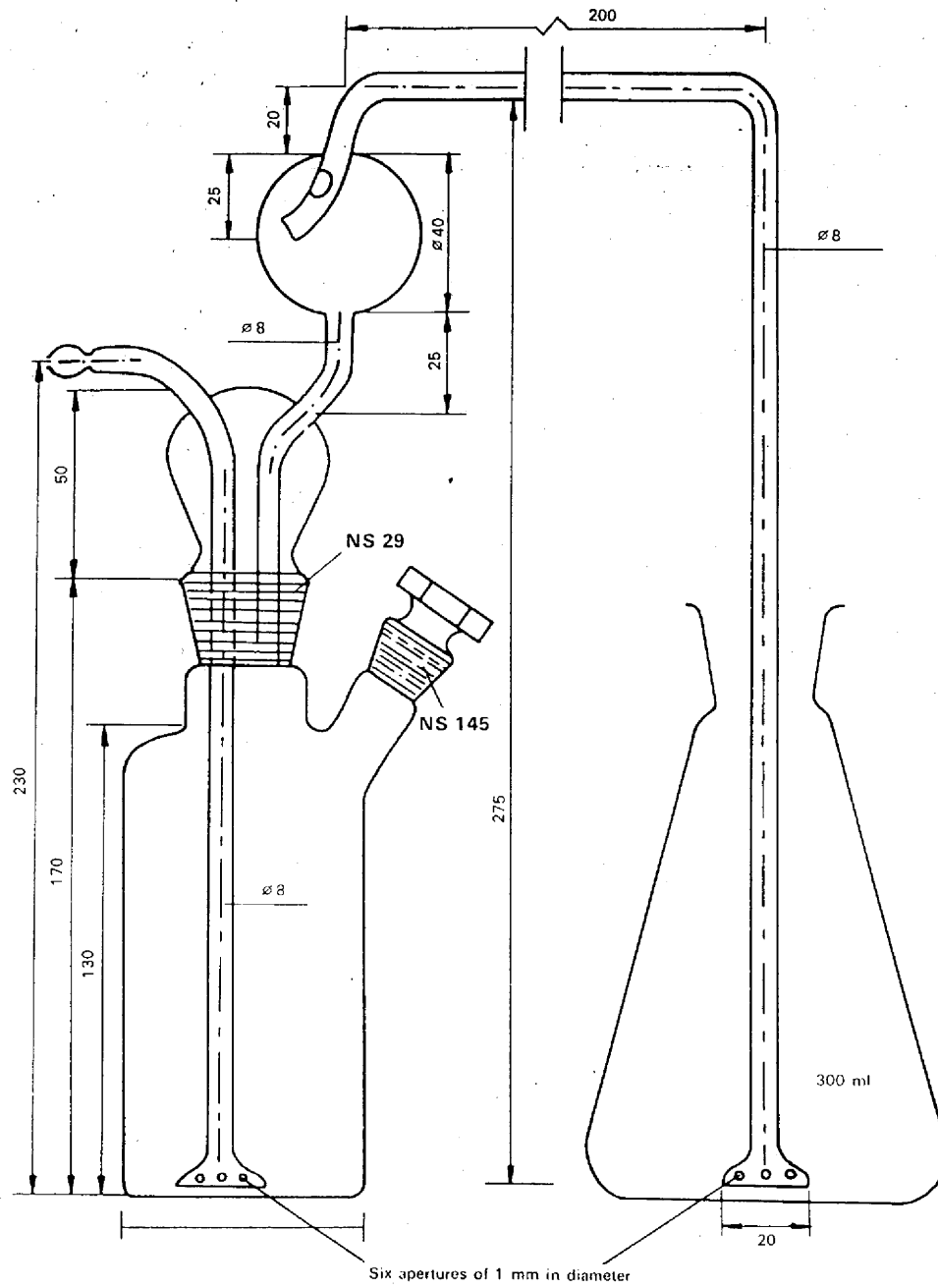
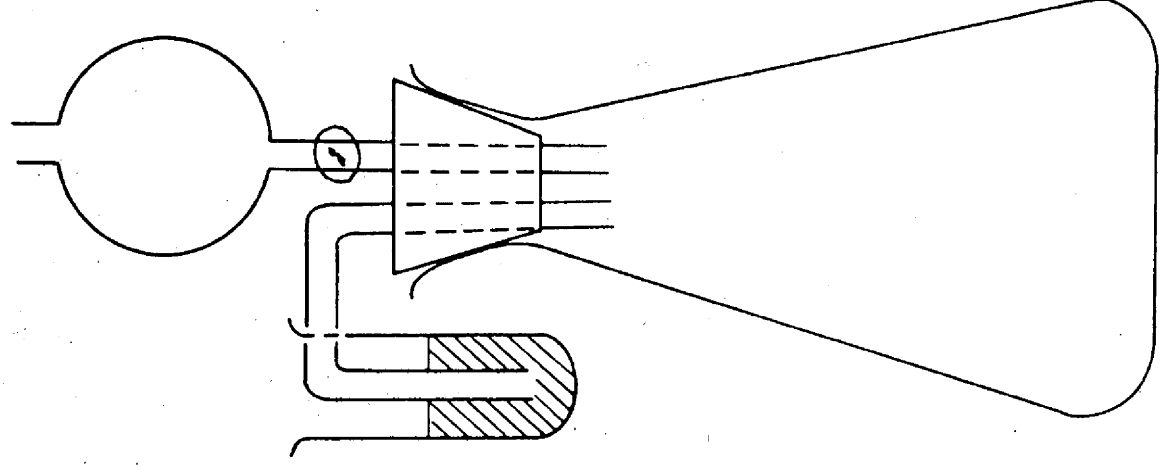

Figure 7

Apparatus for the estimation of urea nitrogen (7.2.6.1)



Method 2.6.2

Determination of different forms of nitrogen in fertilisers containing nitrogen only as nitric, ammoniacal and urea nitrogen**1. Object**

The purpose of the present document is to specify a simplified method for the determination of different forms of nitrogen in fertilisers containing nitrogen only as nitric, ammoniacal and urea nitrogen.

2. Field of application

The present method can be used for all fertilisers mentioned in Annex I which contain exclusively nitric, ammoniacal or urea nitrogen.

3. Principle

The following determinations are made on different portions of a single sample solution:

3.1. Total soluble nitrogen:

3.1.1. in the absence of nitrates, by direct Kjeldahl digestion of the solution,

3.1.2. in the presence of nitrates, by Kjeldahl digestion of a portion of the solution after reduction by the Ulsch method; ammonia is determined in both cases as described in Method 2.1;

3.2. total soluble nitrogen except nitric nitrogen, by Kjeldahl digestion after elimination of nitric nitrogen in acid medium by means of ferrous sulphate; ammonia is determined as described in Method 2.1;

3.3. nitric nitrogen, by the difference between 3.1.2 and 3.2 or between total soluble nitrogen (3.1.2) and the sum of ammoniacal and urea nitrogen (3.4 + 3.5);

3.4. ammoniacal nitrogen, by cold distillation after slight alkalinisation; the ammonia is obtained in a solution of sulphuric acid and determined as in Method 2.1;

3.5. urea nitrogen, either:

3.5.1. by transformation using urease, into ammonia, which is determined by titration with a standard solution of hydrochloric acid,

3.5.2. by gravimetry using xanhydrol: co-precipitated biuret can be taken with urea nitrogen with little error; its level is usually of small absolute value in compound fertilisers,

3.5.3. by difference, following the table:

Case	Nitrate nitrogen	Ammoniacal nitrogen	Difference
1	Absent	Present	(3.1.1) — (3.4)
2	Present	Present	(3.2) — (3.4)

4. Reagents

Distilled or demineralised water.

4.1. Potassium sulphate for analysis

4.2. Iron for analysis, hydrogen reduced (the specified amount of iron must be able to reduce at least 50 mg of nitrate nitric N)

4.3. Potassium nitrate for analysis

4.4. Ammonium sulphate for analysis

4.5. Urea for analysis

4.6. Sulphuric acid solution: 0,2 mol/l

4.7. Concentrated sodium hydroxide solution: approximately 30 % (W/V) aqueous solution of NaOH, free of ammonia

- 4.8. Sodium or potassium hydroxide solution: 0,2 mol/l, free of carbonates
- 4.9. Sulphuric acid density ($d_{20} = 1,84$ g/ml)
- 4.10. Dilute hydrochloric acid: one volume of hydrochloric acid ($d_{20} = 1,18$ g/ml) plus one volume of water
- 4.11. Acetic acid: 96 to 100 %
- 4.12. Sulphuric acid solution containing approximately 30 % H_2SO_4 (W/V), free of ammonia
- 4.13. Ferrous sulphate: crystalline, $FeSO_4 \cdot 7H_2O$
- 4.14. Titrated sulphuric acid solution: 0,1 mol/l
- 4.15. Octyl alcohol
- 4.16. Saturated potassium carbonate solution
- 4.17. Sodium or potassium hydroxide: 0,1 mol/l
- 4.18. Saturated barium hydroxide solution
- 4.19. Sodium carbonate solution: 10 % (W/V)
- 4.20. Hydrochloric acid: 2 mol/l
- 4.21. Hydrochloric acid solution: 0,1 mol/l
- 4.22. *Urease solution*
Make a suspension of 0,5 g of active urease in 100 ml of distilled water, using 0,1 mol/l hydrochloric acid (4.21), adjust the pH to 5,4, measured with pH meter.
- 4.23. *Xanthydrol*
5 % solution in ethanol or methanol (4.28) (do not use products giving a high proportion of insoluble material); the solution can be kept for three months in a carefully stoppered bottle in darkness.
- 4.24. *Catalyst*
Copper oxide (CuO): 0,3 to 0,4 g per determination, or an equivalent amount of copper sulphate pentahydrate ($CuSO_4 \cdot 5H_2O$) of 0,95 to 1,25 g determination.
- 4.25. Pumice stone granules washed with hydrochloric acid and calcined
- 4.26. *Indicator solutions*
- 4.26.1. Mixed indicator
Solution A: Dissolve 1 g of methyl red in 37 ml of 0,1 mol/l sodium hydroxide solution and make up to one litre with water.
Solution B: Dissolve 1 g of methylene blue in water and make up to one litre.
Mix one volume of A with two volumes of B.
This indicator is violet in acid solution, grey in neutral solution and green in alkaline solution. Use 0,5 ml (10 drops) of this indicator.
- 4.26.2. Methyl red indicator solution
Dissolve 0,1 g of methyl red in 50 ml of 95 % ethanol. Make up to 100 ml with water and filter if necessary. Four or five drops of this indicator can be used instead of the previous one.
- 4.27. *Indicator papers*
Litmus, bromothymol blue (or other papers sensitive to pH 6 to 8).
- 4.28. Ethanol or methanol: 95 % (W/V)

5. Apparatus

5.1. Distillation apparatus

See Method 2.1.

5.2. Apparatus for determination of ammoniacal nitrogen (7.5.1)

See Method 2.6.1 and Figure 6.

5.3. Apparatus for determination of urea nitrogen by the urease technique (7.6.1)

See Method 2.6.1 and Figure 7.

5.4. Rotary shaker (35 to 40 turns per minute)

5.5. A pH meter

5.6. Glassware:

precision pipettes of 2, 5, 10, 20, 25, 50 and 100 ml,

long-necked Kjeldahl flasks of 300 and 500 ml,

graduated flasks of 100, 250, 500 and 1 000 ml,

crucibles of sintered glass, pore diameter, 5 to 15 μm ,

mortar.

6. Preparation of the sample

See Method 1.

7. Methods

7.1. Preparation of solution for analysis

Weigh out, to an accuracy of 1 mg, 10 g of sample, and transfer to a 500-ml graduated flask. Add 50 ml water and then 20 ml dilute hydrochloric acid (4.10). Shake. Allow to rest until any CO_2 release comes to an end. Add 400 ml of water; shake for half an hour (5.4); make up to volume with water, homogenise, filter on a dry filter into a dry container.

7.2. Total nitrogen

7.2.1. In absence of nitrates

Pipette into a 300-ml Kjeldahl flask a portion of the filtrate (7.1), containing a maximum of 100 mg N. Add 15 ml of concentrated sulphuric acid (4.9), 0,4 g of copper oxide or 1,25 g of copper sulphate (4.24), and a few glass beads to control boiling. Heat moderately at first in order to initiate the reaction, then more strongly until the liquid becomes colourless or slightly greenish and white fumes unmistakably appear. After cooling, transfer the solution into the distillation flask, dilute to approximately 500 ml with water and add a few granules of pumice stone (4.25). Connect the flask to the distillation apparatus (5.1) and carry out the determination as described in 7.1.1.2, Method 2.6.1.

7.2.2. In the presence of nitrates

Pipette into 500-ml Erlenmeyer a portion of the filtrate (7.1) containing not more than 40 mg of nitric N. At this stage of the analysis, the total quantity of N is unimportant. Add 10 ml of 30 % sulphuric acid (4.12), 5 g of reduced iron (4.2), and immediately cover the Erlenmeyer with a watch glass. Heat gently until the reaction becomes strong but not violent. Stop heating and leave for at least three hours at ambient temperature. Transfer the liquid quantitatively to a 250-ml graduated flask, ignoring undissolved iron. Make up to the mark with water. Homogenise carefully. Pipette a portion containing a maximum of 100 mg N into a 300-ml Kjeldahl flask. Add 15 ml of concentrated sulphuric acid (4.9), 0,4 g of copper oxide or 1,25 g of copper sulphate (4.24), and some glass beads for the control of boiling. Heat moderately at first in order to initiate the reaction, then more strongly until the liquid becomes colourless or slightly greenish and white fumes unmistakably appear. After cooling, transfer the solution quantitatively to the distillation flask, dilute to approximately 500 ml with water, and add a few granules of pumice stone (4.25). Connect the flask to the distillation apparatus (5.1) and continue the determination as described in 7.1.1.2, Method 2.6.1.

7.2.3. Blank test

Carry out a blank test (omitting the sample) under the same conditions, and use the result in calculating the final result.

7.2.4. Expression of the result

$$\% \text{ N (total)} = \frac{(a - A) \times 0,28}{M}$$

where

a = ml of titrated 0,2 mol/l sodium or potassium hydroxide solution (4.8), used in the blank test, carried out by placing 50 ml of titrated 0,2 mol/l sulphuric acid solution into the receiver of the apparatus (4.6),

A = ml of titrated 0,2 mol/l sodium or potassium hydroxide solution (4.8), used for the analysis,

M = mass of the test sample, in grams, present in the aliquot (7.2.1 or 7.2.2).

7.3. *Total nitrogen excluding nitric N*

7.3.1. Analysis

Pipette into a 300-ml Kjeldahl flask an aliquot of filtrate (7.1) containing not more than 50 mg N to be determined. Dilute to 100 ml with water, add 5 g of ferrous sulphate (4.13), 20 ml of concentrated sulphuric acid (4.9), and a few glass beads to control boiling. Heat moderately at first, then more strongly until white fumes appear. Continue the reaction for 15 minutes. Stop heating, introduce 0,4 g of copper oxide or 1,25 g of copper sulphate (4.24) as catalyst. Resume heating and maintain production of white fumes for 10 to 15 minutes. After cooling, transfer the contents of the Kjeldahl flask quantitatively to the distillation flask (5.1). Dilute to approximately 500 ml with water, and add a few granules of pumice stone (4.25). Connect the flask to the distillation apparatus and continue the determination as in 7.1.1.2, Method 2.6.1.

7.3.2. Blank test

See 7.2.3.

7.3.3. Expression of the result

$$\% \text{ N (total)} = \frac{(a - A) \times 0,28}{M}$$

where

a = ml of titrated 0,2 mol/l sodium or potassium hydroxide solution (4.8), used in the blank test, carried out by pipetting 50 ml of titrated 0,2 mol/l sulphuric acid solution (4.6) into the receiver of the apparatus,

A = ml of titrated 0,2 mol/l sodium or potassium hydroxide solution, used for the analysis,

M = mass of the sample, expressed in grams, present in the aliquot used in the determination.

7.4. *Nitric nitrogen*

Is obtained by the difference between:

$$7.2.4 - (7.5.3 + 7.6.3)$$

or

$$7.2.4 - (7.5.3 + 7.6.5)$$

or

$$7.2.4 - (7.5.3 + 7.6.6)$$

7.5. *Ammoniacal nitrogen*

7.5.1. Analysis

Pipette into the dry flask of the apparatus (5.2) a portion of filtrate (7.1) containing a maximum of 20 mg of ammoniacal N. Connect up the apparatus. Pipette into the 300-ml Erlenmeyer exactly 50 ml of titrated 0,1 mol/l sulphuric acid solution (4.14) and an amount of distilled water so that the level of the liquid is approximately 5 cm above the opening of the intake tube. Introduce through the side neck of the reaction flask, distilled water so as to bring the volume to approximately 50 ml. Shake. In order to avoid the formation of froth on the introduction of the gaseous flow, add several drops of octyl alcohol (4.15). Add 50 ml of saturated potassium carbonate solution (4.16), and immediately begin to expel the ammonia thus released from the cold suspension. The intense air flow required for this purpose (flow rate of approximately three litres per minute) is previously purified by passage through washing flasks containing dilute sulphuric acid and dilute sodium hydroxide. Instead of using air under pressure, a vacuum may be used (water suction pump) provided that the connections between the apparatus are air tight.

The elimination of ammonia is generally completed after three hours.

However, it is desirable to make certain of this by changing the Erlenmeyer. When the process is finished, separate the Erlenmeyer from the apparatus, rinse the end of the intake tube and the Erlenmeyer walls with a little distilled water, and titrate the excess acid against a standard 0,1 mol/l sodium hydroxide solution (4.17).

7.5.2. Blank test

See 7.2.3.

7.5.3. Expression of the result

$$\% \text{ N (ammoniacal) } = \frac{(a - A) \times 0,14}{M}$$

where

a = ml of titrated 0,1 mol/l sodium or potassium hydroxide solution (4.17), used in the blank test, carried out by pipetting into the 300-ml Erlenmeyer of the apparatus (5.2) 50 ml of titrated 0,1 mol/l sulphuric acid solution (4.14),

A = ml of titrated 0,1 mol/l sodium or potassium hydroxide solution, used for the analysis (4.17),

M = mass of the sample, expressed in grams, present in the aliquot used for the analysis.

7.6. *Urea nitrogen*

7.6.1. Urease method

Pipette into a 500-ml graduated flask a portion of filtrate (7.1) containing not more than 250 mg of urea nitrogen. To precipitate phosphates, add a suitable quantity of saturated barium hydroxide solution (4.18) until further addition does not cause the production of more precipitate. Eliminate excess barium ions (and any dissolved calcium ions) by means of 10 % sodium carbonate solution (4.19). Allow to settle and check whether precipitation is complete. Make up to the mark, homogenise, and filter through a folder filter. Pipette 50 ml of filtrate into the 300-ml Erlenmeyer of the apparatus (5.3). Acidify with 2 mol/l hydrochloric acid (4.20) to pH 3,0, measured by means of pH meter. Raise the pH to 5,4 by means of 0,1 mol/l sodium hydroxide (4.17). To avoid ammonia losses when hydrolysis by urease occurs, close the Erlenmeyer by means of a stopper attached to a dropping funnel and a small protective container holding exactly 2 ml of 0,1 mol/l hydrochloric acid solution (4.21). By way of the dropping funnel, introduce 20 ml of urease solution (4.22). Leave for one hour at 20 to 25 °C. Pipette 25 ml of the standard 0,1 mol/l hydrochloric acid solution (4.21) into the dropping funnel, allow to run into the solution, then rinse with a little water. Also transfer quantitatively the contents of the protective container to the solution held in the Erlenmeyer. Titrate the excess acid using the standard 0,1 mol/l sodium hydroxide solution (4.17), until a pH of 5,4 is obtained, measured on the pH meter.

Remarks

1. After precipitation by the barium hydroxide and sodium carbonate solutions, make up to the mark, filter, and neutralise as quickly as possible.
2. The titration may also be assessed using the indicator (4.26), although the change of colour is more difficult to observe.

7.6.2. Blank test

See 7.2.3.

7.6.3. Expression of the result

$$\% \text{ N (urea)} = \frac{(a - A) \times 0,14}{M}$$

where

a = ml of titrated 0,1 mol/l sodium or potassium hydroxide solution (4.17), used in the blank test, carried out in exactly the same conditions as the analysis,

A = ml of titrated 0,1 mol/l sodium or potassium hydroxide solution (4.17), used in the analysis,

M = sample mass, expressed in grams, present in the aliquot used for the analysis.

7.6.4. Gravimetric method with xanthydrol

Pipette into a 100-ml beaker a portion of filtrate (7.1) containing not more than 20 mg of urea. Add 40 ml of acetic acid (4.11). Stir with a glass rod for one minute. Allow any precipitate to settle for five minutes. Filter, wash with a few millilitres of acetic acid (4.11). Add 10 ml of xanthydrol to the filtrate drop by drop (4.23), stirring continually with a glass rod. Leave it to settle until the precipitate appears, and at that juncture stir again for one to two minutes. Leave for one and a half hours. Filter on a glass filtration crucible, previously dried and weigh, using a slight reduction of pressure; wash three times with 5 ml of ethanol (4.28), without aiming to eliminate all the acetic acid. Transfer to oven and maintain at 130 °C for one hour (do not exceed 145 °C). Allow to cool in a desiccator and weigh.

7.6.5. Expression of the result

$$\% \text{ N (urea)} = \frac{6,67 \times m}{M}$$

where

m = mass of the precipitate obtained, in grams,

M = mass of the sample, in grams, present in the aliquot used in the determination.

Make the corrections for the blank. Biuret can generally be taken with urea nitrogen without large error, its level being of small absolute value in compound fertilisers.

7.6.6. Difference method

Urea N can also be calculated as indicated in the following table:

Case	Nitric N	Ammoniacal N	Urea N
1	Absent	Present	(7.2.4) — (7.5.3)
2	Present	Present	(7.3.3) — (7.5.3)

8. **Verification of the result**

Before each analysis, check the functioning of the apparatus and the correct application of the methods used with a standard solution containing the different forms of nitrogen in proportions similar to those in the sample. This standard solution is prepared from titrated solutions of potassium nitrate (4.3), ammonium sulphate (4.4) and urea (4.5).

Methods 3

Phosphorus

Methods 3.1

Extractions

Method 3.1.1

Extraction of phosphorus soluble in mineral acids**1. Scope**

This document describes the procedure for the determination of phosphorus soluble in mineral acids.

2. Field of application

Applicable exclusively to the phosphate fertilisers listed in Annex I.

3. Principle

Extraction of the phosphorus in the fertiliser with a mixture of nitric acid and sulphuric acid.

4. Reagents

Distilled or demineralised water.

4.1. Sulphuric acid ($d_{20} = 1,84$ g/ml).

4.2. Nitric acid ($d_{20} = 1,40$ g/ml).

5. Equipment

Standard laboratory equipment.

5.1. A Kjeldahl flask, with a capacity of at least 500 ml, or a 250-ml round-bottomed flask with a glass tube forming a reflux condenser.

5.2. A 500-ml graduated flask.

6. Preparation of the sample

See Method 1.

7. Procedure**7.1. Sample**

Weigh, to the nearest 0,001 g, 2,5 g of the prepared sample and place it in a dry Kjeldahl flask.

7.2. Extraction

Add 15 ml of water and stir so as to suspend the substance. Add 20 ml of nitric acid (4.2) and carefully add 30 ml of sulphuric acid (4.1).

When the initial violent reaction has ceased, slowly bring the contents of the flask to boiling and boil for 30 minutes. Allow to cool and then carefully add with mixing about 150 ml of water. Continue boiling for 15 minutes.

Cool completely and transfer the liquid quantitatively to a 500-ml graduated flask. Make up to volume, mix and filter through a dry pleated filter, free from phosphates, discarding the first portion of the filtrate.

7.3. Determination

The determination of the phosphorus will be carried out by Method 3.2 on an aliquot part of the solution thus obtained.

Method 3.1.2

Extraction of the phosphorus soluble in 2 % formic acid (20 g per litre)**1. Scope**

This document defines the procedure for the determination of phosphorus soluble in 2 % formic acid (20 g per litre).

2. Field of application

Soft natural phosphates exclusively.

3. Principle

To differentiate between hard natural phosphates and soft natural phosphates, phosphorus soluble in formic acid is extracted under specific conditions.

4. Reagents4.1. *Formic acid, 2 % (20 g per litre)*

Note

Make 82 ml of formic acid (concentration 98 to 100 %; $d_{20} = 1,22$ g/ml) up to five litres with distilled water.

5. Apparatus

Standard laboratory equipment.

5.1. A 500-ml graduated flask (e.g. Stohmann)

5.2. Rotary shaker (35 to 40 turns per minute)

6. Preparation of the sample

See Method 1.

7. Procedure7.1. *Sample*

Weigh, to the nearest 0,001 g, 5 g of the prepared sample and place it in a dry 500-ml graduated Stohmann flask (5.1) with a wide neck.

7.2. *Extraction*

While continuously rotating the flask by hand, add the 2 % formic acid at $20 (\pm 1) ^\circ\text{C}$ (4.1) until it is approximately 1 cm below the graduation mark and make up to the volume. Close the flask with a rubber stopper and shake for 30 minutes at $20 (\pm 2) ^\circ\text{C}$ on a rotary shaker (5.2).

Filter the solution through a dry pleated filter, free from phosphates, into a dry glass receptacle. Discard the first portion of the filtrate.

7.3. *Determination*

Determine the phosphorus according to Method 3.2 in an aliquot part of the completely clear filtrate.

Method 3.1.3

Extraction of phosphorus soluble in 2 % citric acid (20 g per litre)**1. Scope**

This document defines the procedure for the determination of phosphorus soluble in 2 % citric acid (20 g per litre).

2. Field of application

Only applicable to types of Basic slag (see Annex I A).

3. Principle

Extraction of phosphorus from the fertiliser with a 2 % citric acid solution (20 g per litre) in given conditions.

4. Reagents

Distilled or demineralised water.

4.1. 2 % citric acid solution (20 g per litre), prepared from crystallised, citric acid ($C_6H_8O_7 \cdot H_2O$)**Note**

Verify the concentration of this citric acid solution by titrating 10 ml of the latter with a sodium hydroxide standard solution 0,1 mol/l, using phenolphthalein as an indicator.

If the solution is correct 28,55 ml of the standard solution should be used.

5. Apparatus**5.1. Rotary shaker (35 to 40 turns per minute)****6. Preparation of the sample**

The analysis is carried out on the product as received after carefully mixing the original sample to ensure it is homogeneous. See Method 1.

7. Procedure**7.1. Sample**

Weigh, to the nearest 0,001 g, 5 g of the prepared sample and place it in a dry flask with a sufficiently wide neck, with a capacity of 600 ml, allowing the liquid to be shaken thoroughly.

7.2. Extraction

Add 500 (± 1) ml of the citric acid solution at 20 (± 1) °C. When adding the first millilitres of the reagent shake vigorously by hand to stop the formation of lumps and to prevent the substance sticking to the sides. Close the flask with a rubber stopper and shake it in the rotary shaker (5.1) for exactly 30 minutes at a temperature of 20 (± 2) °C.

Filter immediately through a dry pleated filter, free of phosphates, into a dry glass receiver and discard the first 20 ml of the filtrate. Continue the filtering until a sufficient quantity of filtrate is obtained to carry out the phosphorus determination.

7.3. Determination

The determination of the phosphorus extract will be carried out according to Method 3.2 on an aliquot part of the solution thus obtained.

Method 3.1.4**Extraction of phosphorus which is soluble in neutral ammonium citrate****1. Scope**

This document defines the procedure for the determination of phosphorus soluble in neutral ammonium citrate.

2. Field of application

All fertilisers in respect of which solubility in neutral ammonium citrate is laid down (see Annex I).

3. Principle

Extraction of phosphorus at a temperature of 65 °C using a neutral ammonium citrate solution (pH 7,0) under specific conditions.

4. Reagent

Distilled or demineralised water.

4.1. Neutral ammonium citrate solution (pH 7,0)

This solution must contain per litre 185 g of crystallised citric acid and must have a specific gravity of 1,09 at 20 °C and a pH of 7,0.

The reagent is prepared as follows:

Dissolve 370 g of crystalline citric acid ($C_6H_8O_7 \cdot H_2O$) in about 1,5 litres of water and make an approximately neutral solution by adding 345 ml of ammonium hydroxide solution (28 to 29 % of NH_3). If the NH_3 concentration is lower than 28 % add a correspondingly larger quantity of ammonium hydroxide solution and dilute the citric acid in correspondingly smaller quantities of water.

Cool and make exactly neutral by keeping the electrodes of a pH meter immersed in the solution. Add the ammonia, at 28 to 29 % of NH_3 , drop by drop, stirring continuously (with a mechanical stirrer) until obtaining exactly a pH of 7,0 at a temperature of 20 °C. At this point make up the volume to two litres and test the pH again. Keep the reagent in a closed container and check the pH at regular intervals.

5. Apparatus

5.1. A two-litre beaker

5.2. A pH meter

5.3. A 200 or 250-ml Erlenmeyer flask

5.4. 500-ml graduated flasks and a 2,000-ml graduated flask

5.5. Water bath which can be set thermostatically at 65 °C, equipped with a suitable stirrer (see Figure 8)

6. Preparation of the sample

See Method 1.

7. Procedure**7.1. Sample**

Transfer 1 or 3 g of the fertiliser to be analysed (see Annex I A and B to the Regulation) into a 200 or 250-ml Erlenmeyer flask containing 100 ml of ammonium citrate solution previously heated to 65 °C.

7.2. Analysis of the solution

Stopper the Erlenmeyer flask and shake in order to suspend the fertiliser without forming lumps. Remove the stopper for an instant in order to balance the pressure and close the Erlenmeyer flask again. Place the flask in a water bath set to maintain the contents of the flask at exactly 65 °C and connect it to the stirrer (see Figure 8). During stirring, the level of the suspension in the flask must stay constantly below the level of the water in the water bath ⁽¹⁾. Mechanical stirring will be regulated so as to ensure complete suspension.

After stirring for exactly one hour, remove the Erlenmeyer flask from the water bath.

Cool immediately under running water to ambient temperature and, immediately, quantitatively transfer the contents from the Erlenmeyer flask into a graduated 500-ml flask with a jet of water (wash bottle). Make up the volume with water. Mix thoroughly. Filter through a dry pleated filter (medium speed phosphate free) into a dry container, discarding the first part of the filtrate (about 50 ml).

About 100 ml of clear filtrate will then be collected.

7.3. Determination

Determine the phosphorus of the extract thus obtained according to Method 3.2.

⁽¹⁾ If no mechanical stirrer is available, the flask may be shaken by hand every five minutes.

Figure 8

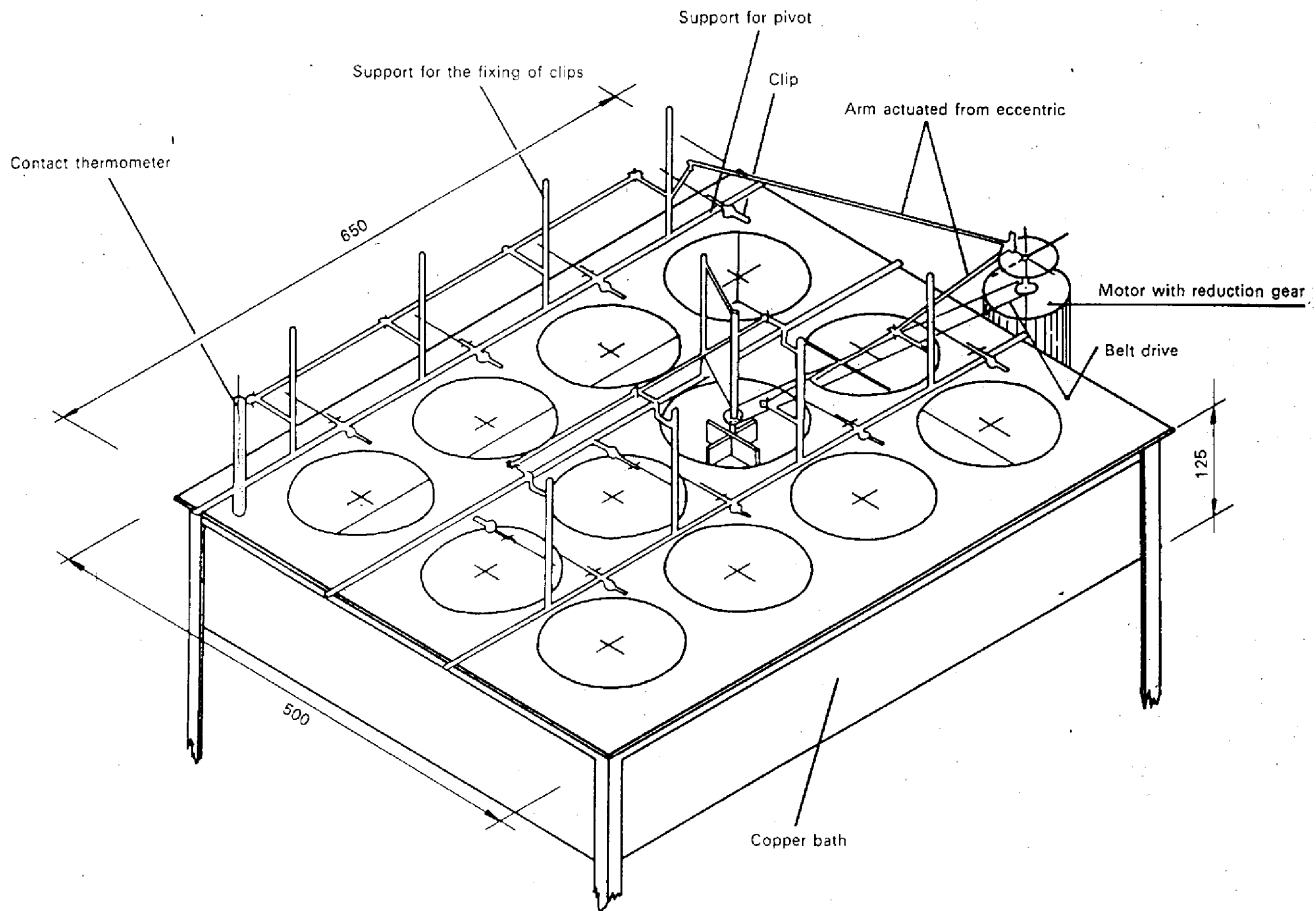

Methods 3.1.5

Extraction by alkaline ammonium citrate

Method 3.1.5.1

Extraction of soluble phosphorus according to Petermann at 65 °C

1. Scope

This document defines the procedure for the determination of soluble phosphorus in alkaline ammonium citrate.

2. Field of application

Exclusively to precipitated dihydrated dicalcium phosphate ($\text{CaHPO}_4 \cdot 2\text{H}_2\text{O}$).

3. Principle

Extraction of phosphorus at a temperature of 65 °C with an alkaline solution of ammonium citrate (Petermann) under specified conditions.

4. Reagents

Distilled water, or demineralised water having the same characteristics as distilled water.

4.1. Petermann's solution.

4.2. *Characteristics*

Citric acid ($C_6H_8O_7 \cdot H_2O$): 173 g per litre.

Ammonia: 42 g per litre of ammoniacal nitrogen.

pH between 9,4 and 9,7.

Preparation from diammonium citrate

Dissolve 931 g of diammonium citrate (molecular mass 226,19) in about 3 500 ml of water, in a five-litre standard flask. Stand in a bath of running water, mix and cool and add in small amounts ammonia. For example, for $d_{20} = 906$ g/ml corresponding to a level of 20,81 % by mass of ammoniacal nitrogen, it is necessary to use 502 ml of ammonia solution. Adjust the temperature to 20 °C, make up to volume with distilled water. Mix.

Preparation from citric acid and ammonia

Dissolve 865 g of citric acid monohydrate in about 2 500 ml of distilled water in a container of about five-litres capacity. Place the container in an ice bath, and add in small amounts, shaking constantly, ammonia solution using a funnel, the stem of which is immersed in the citric acid solution. For example, for $d_{20} = 906$ g/ml corresponding to a level of 20,81 % by mass of ammoniacal nitrogen, it is necessary to add 1 114 ml of ammonia solution. Adjust the temperature to 20 °C, transfer to a five-litre standard flask, make up to the mark with distilled water and mix.

Check the ammoniacal nitrogen content as follows

Transfer 25 ml of the solution into a 250-ml standard flask and make up to volume with distilled water. Mix. Determine the ammoniacal content on 25 ml of this solution following Method 2.1. If the solution is correct, one must use 15 ml of 0,5 N mol/l H_2SO_4 .

If the strength of ammoniacal nitrogen is greater than 42 g per litre, NH_3 can be expelled by a stream of inert gas or by moderate heating to bring back the pH to 9,7. Carry out a second determination.

If the strength of ammoniacal nitrogen is less than 42 g per litre, it will be necessary to add a mass M of ammonia solution:

$$M = (42 - n \times 2,8) \times \frac{500}{20,81} \text{ g}$$

or a volume $V = \frac{M}{0,906}$ at 20 °C.

If V is less than 25 ml, add it directly to the five-litre flask with a mass of $V \times 0,173$ g powdered citric acid.

If V is greater than 25 ml, it will be convenient to make a new litre of reagent in the following way.

Weigh 173 g of citric acid. Dissolve it in 500 ml of water. And, taking the precautions indicated, add not more than $225 + V \times 1 206$ ml of ammonia solution which was used to prepare the five litres of reagent. Make up to volume with water. Mix.

Mix this litre with the 4 975 ml previously prepared.

5. **Apparatus**

5.1. Water bath which can be maintained at a temperature of 65 (± 1) °C

5.2. A 500-ml graduated flask (e.g. Stohmann)

6. **Preparation of the sample**

See Method 1.

7. Procedure**7.1. Sample**

Weigh, to the nearest 0,001 g, 1 g of the prepared sample and transfer to the 500-ml graduated flask (5.2).

7.2. Extraction

Add 200 ml of alkaline ammonium citrate solution (4.1). Stopper the flask and shake vigorously by hand to avoid the formation of lumps and to prevent any adherence of the substance to the sides.

Place the flask in the water bath set at 65 °C and shake every five minutes during the first half an hour. After each shaking, raise the stopper to equilibrate the pressure. The level of water in the water bath ought to be above the level of solution in the flask. Allow the flask to remain in the water bath a further hour at 65 °C and shake every 10 minutes. Remove the flask, cool to a temperature of about 20 °C, make up to a volume of 500 ml with water. Mix and filter through a dry fluted filter paper, free from phosphates, rejecting the first portion of filtrate.

7.3. Determination

The determination of phosphate extracted will be carried out by Method 3.2 on an aliquot part of the solution thus obtained.

Method 3.1.5.2**Extraction of the soluble phosphorus according to Petermann at ambient temperature****1. Scope**

This document defines the procedure for the determination of phosphorus soluble in cold alkaline ammonium citrate.

2. Field of application

Disintegrated phosphates exclusively.

3. Principle

Extraction of phosphorus at a temperature about 20 °C with an alkaline solution of ammonium citrate (Petermann's solution) in specific conditions.

4. Reagent

See Method 3.1.5.1.

5. Apparatus

5.1. Standard laboratory equipment, and a 250-ml graduated flask (e.g. Stohmann)

5.2. Rotary shaker (35 to 40 turns per minute)

6. Preparation of the sample

See Method 1.

7. Procedure**7.1. Sample**

Weigh, to the nearest 0,001 g, 2,5 g of the prepared sample and place it in a 250-ml graduated flask (5.1).

7.2. Extraction

Add a little of Petermann's solution at 20 °C, shake very hard in order to stop the formation of lumps and to prevent any of the substance adhering to the side of the flask. Make up to the graduation mark with Petermann's solution and close the flask with a rubber stopper.

Shake for two hours in the rotary shaker (5.2). Filter immediately through a dry pleated filter, free from phosphate, into a dry container, discarding the first portion of the filtrate.

7.3. *Determination*

The phosphorus determination will be carried out by Method 3.2 on an aliquot part of the solution thus obtained.

Method 3.1.5.3

Extraction of the phosphorus soluble in Joulie's alkaline ammonium citrate

1. **Scope**

This document defines the procedure for the determination of phosphorus soluble in Joulie's alkaline ammonium citrate.

2. **Field of application**

All the straight and compound phosphate fertilisers, in which the phosphate occurs in an aluminocalcic form.

3. **Principle**

Extraction by shaking vigorously with an alkaline solution of ammonium citrate of defined specification (and where appropriate in the presence of oxine) at about 20 °C.

4. **Reagents**

Distilled or demineralised water.

4.1. *Joulie's alkaline solution of ammonium citrate.*

This solution contains 400 g of citric acid and 153 g of NH₃ per litre. Its free ammonia content is approximately 55 g per litre. It can be prepared by one of the methods described below.

4.1.1. In a one-litre graduated flask, dissolve 400 g of citric acid (C₆H₈O₇·H₂O) in approximately 600 ml of ammonia (d₂₀ = 0,925 g/ml i.e. 200 g of NH₃ per litre). The citric acid is added successively in quantities of 50 to 80 g maintaining the temperature below 50 °C. Make up the volume to one litre with ammonia.

4.1.2. In a one-litre graduated flask, dissolve 432 g of dibasic ammonium citrate (C₆H₁₄N₂O₇) in 300 ml of water. Add 440 ml of ammonia (d₂₀ = 0,925 g/ml). Make the volume up to one litre with water.

Note

Verification of the total ammonia content.

Take a 10-ml sample of the citrate solution and place it in a 250-ml flask. Make up the volume with distilled water. Determine the ammoniacal nitrogen content on 25 ml of this solution according to Method 2.1.

$$1 \text{ ml of H}_2\text{SO}_4 \text{ 0,5 mol/l} = 0,008516 \text{ g of NH}_3$$

In these conditions, the reagent is considered to be correct when the number of millilitres found upon titration lies between 17,7 and 18 ml.

If this is not so add 4,25 ml of ammonia (d₂₀ = 0,925 g/l) per 0,1 ml below 18 ml indicated above.

4.2. Powdered 8-hydroxyquinoline (oxine)

5. **Apparatus**

5.1. Standard laboratory equipment and small mortar in glass or porcelain with pestle

5.2. 500-ml graduated flasks

5.3. A 1 000-ml graduated flask

5.4. Rotary shaker (35 to 40 turns per minute)

6. Preparation of the sample

See Method 1.

7. Procedure**7.1. Sample**

Weigh, to the nearest 0,0005 g, 1 g of the prepared sample and place in a small mortar. Add about 10 drops of citrate (4.1) to moisten it and break it up very carefully with the pestle.

7.2. Extraction

Add 20 ml of ammonium citrate (4.1) and mix to a paste, leave it to settle for about one minute.

Decant the liquid into a 500-ml graduated flask, straining off particles which might have escaped the preceding moist disintegration. Add 20 ml of citrate solution (4.1) to the residue, grind as above and decant the liquid into the graduated flask. Repeat the process four times, so that by the end of the fifth time all the product can be poured into the flask. The total quantity of citrate used for these processes must be approximately 100 ml.

Rinse the pestle and mortar above the graduated flask with 40 ml of distilled water.

The stoppered flask is shaken for three hours on the rotary shaker (5.4).

Leave the flask standing for 15 to 16 hours, shake it again under same conditions for three hours. The temperature during the whole process is kept at 20 (± 2) °C.

Make up to the graduation mark with distilled water. Filter through a dry filter, discard the first portion of the filtrate and collect the clear filtrate in a dry flask.

7.3. Determination

The estimation of the extracted phosphorus will be carried out according to Method 3.2 on an aliquot part of the solution thus obtained.

8. Appendix

The use of oxine makes it possible to apply this Method to fertilisers containing magnesium. This use is recommended when the ratio of magnesium and phosphoric anhydride contents is higher than 0,03 ($Mg/P_2O_5 > 0,03$). If this is the case, add 3 g of oxine to the moistened sample for analysis. The use of oxine in the absence of magnesium is not, moreover, likely to interfere subsequently with the determination. In the known absence of magnesium it is, however, possible not to use oxine.

Method 3.1.6**Extraction of water soluble phosphorus****1. Scope**

This document defines the procedure for the determination of water soluble phosphorus.

2. Field of application

All fertilisers, including compound fertilisers, where water soluble phosphorus is to be determined.

3. Principle

Extraction in water by shaking under specific conditions.

4. Reagent

Distilled or demineralised water.

5. Apparatus

- 5.1. A 500-ml graduated flask (e.g. Stohmann)

- 5.2. Rotary shaker (35 to 40 turns per minute)
6. **Preparation of the sample**
See Method 1.
7. **Procedure**
- 7.1. *Sample*
Weigh, to the nearest 0,001 g, 5 g of the prepared sample and place it in a 500-ml graduated flask (5.1).
- 7.2. *Extraction*
Add to the flask 450 ml of water, the temperature of which must be between 20 and 25 °C.
Shake in the rotary shaker (5.2) for 30 minutes.
Then make up to the mark with water, mix thoroughly by shaking and filter through a dry pleated filter, free of phosphate, into a dry container.
- 7.3. *Determination*
The estimation of phosphorus will be carried out on an aliquot part of the solution thus obtained by Method 3.2.

Method 3.2

Determination of extracted phosphorus (Gravimetric Method Using Quinoline Phosphomolybdate)

1. **Scope**
This document defines the procedure for the determination of phosphorus in the extracts from fertilisers.
2. **Field of application**
The Method is applicable to all extracts of fertilisers⁽¹⁾ for the determination of the different forms of phosphorus.
3. **Principle**
After possible hydrolysis of the different forms of phosphorus other than orthophosphates, the orthophosphated ions are precipitated in an acid medium in the form of quinoline phosphomolybdate.
After filtering and washing, the precipitate is dried at 250 °C and weighed.
In the abovementioned conditions no interfering action is exerted by the compounds likely to be found in the solution (mineral and organic acids, ammonium ions, soluble silicates, etc.) if a reagent based on sodium molybdate or ammonium molybdate is used in the precipitation.
4. **Reagents**
Distilled or demineralised water.
- 4.1. Concentrated nitric acid ($d_{20} = 1,40$ g/ml)
- 4.2. *Preparation of reagent*
- 4.2.1. Preparation of the reagent based on sodium molybdate
Solution A: Dissolve 70 g of sodium molybdate dihydrate in 100 ml of distilled water.
Solution B: Dissolve 60 g of citric acid monohydrate in 100 ml of distilled water and add 85 ml concentrated nitric acid (4.1).
Solution C: Stir solution A into solution B to obtain solution C.

⁽¹⁾ Phosphorus soluble in mineral acids, water soluble phosphorus, phosphorus soluble in solutions of ammonium citrate, phosphorus soluble in 2 % citric acid and phosphorus soluble in 2 % formic acid.

Solution D: To 50 ml of distilled water, add 35 ml of concentrated nitric acid (4.1), then 5 ml of freshly distilled quinoline. Add this solution to solution C, mix thoroughly and leave standing overnight in the dark. After this make up to 500 ml with distilled water, mix again, and filter through a sintered glass funnel (5.6).

4.2.2. Preparation of the reagent based on ammonium molybdate

Solution A: In 300 ml of distilled water, dissolve 100 g of ammonium molybdate while heating gently and stirring from time to time.

Solution B: Dissolve 120 g of citric acid monohydrate in 200 ml of distilled water, add 170 ml of concentrated nitric acid (4.1).

Solution C: Add 10 ml of freshly distilled quinoline to 70 ml of concentrated nitric acid (4.1).

Solution D: Slowly pour, stirring well, solution A into solution B. After thoroughly mixing add solution C to this mixture and make up to one litre. Leave standing for two days in a dark place and filter through a sintered glass funnel (5.6).

The Reagents 4.2.1 and 4.2.2 can be used in the same way; both must be kept in the dark in stoppered polyethylene bottles.

5. Apparatus

5.1. Standard laboratory equipment and a 500-ml Erlenmeyer flask with a wide neck

5.2. Graduated pipettes of 10, 25 and 50 ml

5.3. Filter crucible with porosity of 5 to 20 μm

5.4. Buchner flask

5.5. Drying oven regulated at 250 (+ 10) °C

5.6. Sintered glass funnel with porosity of 5 to 20 μm

6. Procedure

6.1. Treatment of the solution

With a pipette, take an aliquot part of fertiliser extract (see Table 2) containing about 0,01 g of P_2O_5 and put it in a 500-ml Erlenmeyer flask. Add 15 ml of concentrated nitric acid ⁽¹⁾ (4.1) and dilute with water to about 100 ml.

Table 2

Determining the aliquot parts of the phosphate solutions

% P_2O_5 in the fertiliser	% P in the fertiliser	Sample for analysis (g)	Dilution (to ml)	Sample (ml)	Dilution (to ml)	Sample to be precipitated (ml)	Quinoline phospho-molybdate conversion factor (F), in % P_2O_5	Quinoline phospho-molybdate conversion factor (F'), in % P
5-10	2.2-4.4	1	500	—	—	50	32,074	13,984
		5	500	—	—	10	32,074	13,984
10-25	4.4-11.0	1	500	—	—	25	64,148	27,968
		5	500	50	500	50	64,148	27,968
+ 25	+ 11	1	500	—	—	10	160,370	69,921
		5	500	50	500	25	128,296	55,937

⁽¹⁾ 21 ml when the solution to be precipitated contains more than 15 ml of citrate solution (neutral citrate, Petermann or Joulie alkaline citrate).

6.2. *Hydrolysis*

If the presence of metaphosphates, pyrophosphates or polyphosphates is suspected in the solution, hydrolysis is carried out as follows.

Bring the contents of the Erlenmeyer flask to the boil slowly and keep at this temperature until hydrolysis is completed (this usually takes one hour). Care must be taken to avoid losses by splashing and excessive evaporation which could reduce the initial volume by more than half, by fitting a reflux condenser. After Hydrolysis make up to the initial volume with distilled water.

6.3. *Weighing the crucible*

Dry the filter crucible (5.3) for at least 15 minutes in the drying oven set at 250 (\pm 10) °C. Weigh it after it has been cooled in a desiccator.

6.4. *Precipitation*

The acid solution contained in the Erlenmeyer flask is heated until it begins to boil then precipitation of the quinoline phosphomolybdate is started by adding 40 ml of the precipitating reagent (reagent 4.2.1 or 4.2.2) ⁽¹⁾ drop by drop, stirring continuously. Place the Erlenmeyer flask in a steam bath, leave it there for 15 minutes, shaking it from time to time. The solution can be filtered immediately or after it has cooled down.

6.5. *Filtering and washing*

Filter the solution under vacuum by decantation. Wash the precipitate in the Erlenmeyer flask with 30 ml of water. Decant and filter the solution. Repeat this process five times. Quantitatively transfer the rest of the precipitate into the crucible washing it with water. Wash four times with 20 ml of water, allowing the liquid to drain from the crucible before each addition. Dry the precipitate thoroughly.

6.6. *Drying and weighing*

Wipe the outside of the crucible with a filter paper. Place this crucible in a drying oven and keep it there until its mass remains constant, at a temperature of 250 °C (5.5) (usually 15 minutes); leave it to cool in the desiccator at ambient temperature and weigh rapidly.

6.7. *Blank test*

For each series of determinations, carry out a blank test using only the reagents and solvents in the proportions used in the extraction (citrate solution, etc.) and allow for them in the calculation of the final result.

6.8. *Verification*

Carry out the determination using an aliquot part of a potassium dihydrogen phosphate solution containing 0,01 g of P₂O₅.

7. **Expression of the result**

If the samples for analysis and dilutions shown in Table 2 are used, the following formula applies:

$$\% \text{ P in the fertiliser} = (A - a) F'$$

or

$$\% \text{ P}_2\text{O}_5 \text{ in the fertiliser} = (A - a) F$$

where

A = mass, in grams, of the quinoline phosphomolybdate,

a = mass, in grams, of the quinoline phosphomolybdate obtained in the blank test,

F and F' = factors given in the last two columns of Table 2.

⁽¹⁾ To precipitate phosphate solutions containing more than 15 ml of citrate solution (neutral, Petermann or Joulie) which have been acidified with 21 ml of concentrated nitric acid (see footnote to 6.1) use 80 ml of the precipitating reagent.

With samples for analysis and dilutions which differ from those of Table 2, the following formula applies:

$$\% \text{ P in the fertiliser} = \frac{(A - a) \times f' \times D \times 100}{M}$$

or

$$\% \text{ P}_2\text{O}_5 \text{ in the fertiliser} = \frac{(A - a) \times f \times D \times 100}{M}$$

where

f and f' = conversion factors of quinoline phosphomolybdate into $\text{P}_2\text{O}_5 = 0,032074$, (f) or into $\text{P} = 0,013984$ (f'),

D = dilution factor,

M = mass, in grams, of the sample analysed.

Method 4

Potassium

Method 4.1

Determination of the water soluble potassium content

1. Scope

This document defines the procedure for the determination of water soluble potassium.

2. Field of application

All the potassium fertilisers listed in Annex I.

3. Principle

The potassium in the sample to be analysed is dissolved in water. After eliminating or fixing the substances which might interfere with the quantitative determination, the potassium is precipitated in a slightly alkaline medium in the form of potassium tetraphenylborate.

4. Reagents

Distilled or demineralised water.

4.1. Formaldehyde

Clear formaldehyde solution at 25 to 35 %.

4.2. Potassium chloride for analysis

4.3. Sodium hydroxide solution: 10 mol/l

Care should be taken to ensure that only potassium free sodium hydroxide is used.

4.4. Indicator solution

Dissolve 0,5 g of phenolphthalein in ethanol at 90 % and make the volume up to 100 ml.

4.5. EDTA solution

Dissolve 4 g of the dihydrated disodium salt of ethylenediaminetetraacetic acid in water in a 100-ml graduated flask. Make up the volume and mix.

Store the reagent in a plastic container.

4.6. *STPB solution*

Dissolve 32,5 g of sodium tetraphenylborate in 480 ml of water add 2 ml of the sodium hydroxide solution (4.3) and 20 ml of a magnesium chloride solution (100 g of $MgCl_2 \cdot 6H_2O$ per litre).

Stir for 15 minutes and filter through a fine, ashless filter.

Store this reagent in a plastic container.

4.7. *Liquid for washing*

Dilute 20 ml of the STPB solution (4.6) to 1 000 ml with water.

4.8. *Bromine water*

Saturated bromine solution in water.

5. **Apparatus**

5.1. 1 000-ml graduated flasks

5.2. A 250-ml beaker

5.3. Filter crucibles with a porosity of 5 to 20 μ 5.4. Oven regulated at 120 (\pm 10) °C

5.5. Desiccator

6. **Preparation of the sample**

See Method 1.

In the case of potassium salts the sample must be ground fine enough in order that a representative sample is obtained for analysis. For these products Method 1 (6) (a) must be used.

7. **Procedure**7.1. *Sample*

Weigh, to the nearest 0,001 g, 10 g of the prepared sample (5 g for potassium salts containing more than 50 % of potassium oxide). Place this test sample in a 600-ml beaker with approximately 400 ml of water.

Bring to the boil and allow it to boil for 30 minutes. Cool, transfer quantitatively into a 1 000 ml graduated flask, make up the volume, mix and filter into a dry receiver. Discard the first 50 ml of the filtrate (see 7.6, note on procedure).

7.2. *Preparation of the aliquot part for precipitation*

Transfer by pipette an aliquot part of the filtrate containing 25 to 50 mg of potassium (see Table 3) and place it in a 250-ml beaker. If required make up to 50 ml with water.

To remove any interference, add 10 ml of the EDTA solution (4.5), several drops of the phenolphthalein solution (4.4) and stir in, drop by drop, sodium hydroxide solution (4.3) until it turns red, then finally add a few more drops of sodium hydroxide to ensure an excess (usually 1 ml of sodium hydroxide is sufficient to neutralise the sample and ensure an excess).

To eliminate most of the ammonia (see 7.6 (b), note on procedure) boil gently for 15 minutes.

If necessary add water to make the volume up to 60 ml.

Bring the solution to the boil, remove the beaker from the heat and add 10 ml of formaldehyde (4.1). Add several drops of phenolphthalein and, if necessary, some more sodium hydroxide, until a distinct red colour appears. Cover the beaker with a watch glass and place it on a steam bath for 15 minutes.

7.3. *Weighing the crucible*

Dry the filter crucible (see 5 'Apparatus') to constant mass (about 15 minutes) in the oven at 120 °C (5.4).

Allow the crucible to cool in a desiccator and then weigh it.

7.4. *Precipitation*

Remove the beaker from the steam bath, stir in drop by drop 10 ml of the STPB solution (4.6). This addition takes about two minutes. Wait for at least 10 minutes before filtering.

7.5. *Filtering and washing*

Filter under vacuum into the weighed crucible, rinse the beaker with the liquid for washing (4.7), wash the precipitate three times with the liquid for washing (60 ml in all of the liquid for washing) and twice with 5 to 10 ml of water.

Dry the precipitate thoroughly.

7.6. *Drying and weighing*

Wipe the outside of the crucible with a filter paper. Place the crucible with its contents in the oven for one and a half hours at a temperature of 120 °C. Allow the crucible to cool in a desiccator to ambient temperature and weigh rapidly.

Note on procedure

(a) If the filtrate is dark in colour, transfer by pipette, an aliquot part containing at the most 100 mg of K₂O and place in a 100-ml graduated flask, add bromine water and bring to the boil to eliminate any surplus bromine. After cooling make up the volume, filter and quantitatively determine the potassium in an aliquot part of the filtrate.

(b) Where there is little or no ammoniacal nitrogen present, there is no need to boil for 15 minutes.

7.7. *Aliquot parts to be taken as samples and conversion factors*

Table 3

For Method 4

% K ₂ O in the fertiliser	% K in the fertiliser	Sample for analysis (g)	Sample of the extract solution for the dilution (ml)	Dilution (to ml)	Aliquot part to be taken as a sample for precipitation (ml)	Conversion factor (F) $\frac{\% K_2O}{gTPBK}$	Conversion factor F' $\frac{\% K}{gTPBK}$
5-10	4,2-8,3	10	—	—	50	26,280	21,812
10-20	8,3-16,6	10	—	—	25	52,560	43,624
20-50	16,6-41,5	10	either — or 50	—	10	131,400	109,060
				250	50	131,400	109,060
more than 50	more than 41,5	5	either — or 50	—	10	262,800	218,120
				250	50	262,800	218,120

7.8. *Blank test*

For each series of determinations, carry out a blank test using only the reagents in the proportions used in the analysis and allow for this when calculating the final result.

7.9. *Control test*

In order to obtain a control for the method of analysis, carry out a determination on an aliquot part of an aqueous solution of potassium chloride, containing at the most 40 mg of K₂O.

8. **Expression of the result**

If one uses the samples for analysis and the dilutions shown in Table 3, the formula to apply is the following:

$$\% K_2O \text{ in the fertiliser} = (A - a) F$$

or

$$\% \text{ K in the fertiliser} = (A - a) F'$$

where

A = mass, in grams, of the precipitate from the sample,

a = mass, in grams, of the precipitate from the blank,

F and F' = factors (see Table 3).

With samples and dilutions which differ from those shown in Table 3, use the following formula:

$$\text{K}_2\text{O in the fertiliser} = \frac{(A - a) \times f \times D \times 100}{M}$$

or

$$\text{K in the fertiliser} = \frac{(A - a) \times f' \times D \times 100}{M}$$

where

f = conversion factor, KTPB into K₂O = 0,1314,

f' = conversion factor, KTPB into K = 0,109,

D = dilution factor,

M = mass, in grams, of sample for analysis.

Method 5

No item

Method 6

Chlorine

Method 6.1

Determination of chlorides in the absence of organic material

1. Scope

This document defines the procedure for the determination of chloride, in the absence of organic material.

2. Field of application

All fertilisers which are free from organic material.

3. Principle

The chlorides, dissolved in water, are precipitated in an acid medium by an excess of standard solution of silver nitrate. The excess is titrated with a solution of ammonium thiocyanate in the presence of ferric ammonium sulphate (Volhard's method).

4. Reagents

Distilled or demineralised water, free from chlorides.

4.1. Nitrobenzene or diethyl ether

4.2. Nitric acid: 10 mol/l

4.3. *Indicator solution*

Dissolve 40 g of ferric ammonium sulphate $\text{Fe}_2(\text{SO}_4)_3 \cdot (\text{NH}_4)_2\text{SO}_4 \cdot 24\text{H}_2\text{O}$, in water and make up to one litre.

4.4. *Silver nitrate standard solution: 0,1 mol/l*

Preparation

Since this salt is hygroscopic and cannot be dried without risk of decomposition, it is advisable to weigh out approximately 9 g, dissolve in water and make up the volume to one litre. Adjust to 0,1 mol/l strength by titration of AgNO_3 0,1 mol/l.

5. **Apparatus**

5.1. Rotary shaker (35 to 40 turns per minute)

5.2. Burettes

5.3. A 500-ml graduated flask

5.4. Conical (Erlenmeyer) flask of 250 ml

6. **Preparation of the sample**

See Method 1.

7. **Procedure**

7.1. *Sample and preparation of the solution*

Place 5 g of the sample, weighed out to nearest 0,001 g, in a 500-ml graduated flask and add 450 ml of water. Mix for half an hour on the shaker (5.1); make up to 500 ml with distilled water; mix and filter into a beaker.

7.2. *Determination*

Take an aliquot part of the filtrate containing not more than 0,150 g of chloride. For example 25 ml (0,25 g), 50 ml (0,5 g) or 100 ml (1 g). If the sample taken is smaller than 50 ml it is necessary to make up the volume to 50 ml with distilled water.

Add 5 ml of nitric acid 10 mol/l (4.2), 20 ml of indicator solution (4.3), and two drops of ammonium thiocyanate standard solution (a sample of this latter reagent is taken with a burette adjusted to zero for this purpose).

With a burette then add silver nitrate standard solution (4.4) until there is an excess of 2 to 5 ml. Add 5 ml of nitrobenzene or 5 ml of diethyl ether (4.1) and shake well to agglomerate the precipitate. Titrate the excess silver nitrate with ammonium thiocyanate 0,1 mol/l (4.5) until a red-brown colour appears which remains after the flask has been shaken slightly.

Note

Nitrobenzene or diethyl ether (but above all nitrobenzene) prevents the silver chloride from reacting with thiocyanate ions. Thus a clear colour change is obtained.

7.3. *Blank test*

Carry out a blank test (omitting the sample) under the same conditions and allow for it when calculating the final result.

7.4. *Control test*

Before carrying out the estimations check the accuracy of the Method by using an aliquot part of a freshly prepared solution of potassium chloride, such that this part contains a known quantity in the order of 100 mg of chloride.

8. Expression of the result

Express the result of the analysis as a percentage of chloride contained in the sample as it has been received for analysis.

Calculate the percentage of chloride (Cl) with the formula:

$$\% \text{ chloride} = 0,003546 \times \frac{(V_z - V_{cz}) - (V_a - V_{ca}) \times 100}{M}$$

where

V_z = number of millilitres of silver nitrate 0,1 mol/l,

V_{cz} = number of millilitres of silver nitrate 0,1 mol/l, used in the blank test,

V_a = number of millilitres of ammonium thiocyanate 0,1 mol/l,

V_{ca} = number of millilitres of ammonium thiocyanate 0,1 mol/l, used in the blank test,

M = mass, in grams, of the sample taken (7.2).

Methods 7

Fineness of grinding

Method 7.1

Determination of fineness of grinding

(dry procedure)

1. Scope

This document defines the dry procedure, for the determination of the fineness of grinding.

2. Field of application

All EC type fertilisers in which requirements are given of fineness of grinding using 0,630 and 0,160 mm sieves.

3. Principle

By mechanical sieve shaking, the quantities of product with a granule size greater than 0,630 mm and those with a granule size between 0,160 and 0,630 mm are determined, and the percentage of fineness of grinding is calculated.

4. Apparatus

4.1. Mechanical sieve shaker

4.2. Sieves with apertures of 0,160 and 0,630 mm respectively of standard ranges (20 cm diameter and 5 cm high)

5. Procedure

Weigh, to the nearest 0,05 g, 50 g of the substance. Assemble the two sieves and the collecting container on the shaker (4.1), the sieve with the larger apertures being placed on top. Place the sample for analysis on the top. Sieve for 10 minutes and remove the part collected on the bottom. Start the apparatus up again and after one minute check that the amount collected on the bottom during this time is not more than 250 mg. Repeat the process (for one minute each time) until the amount collected is less than 250 mg. Weigh the residual material on both sieves separately.

6. Expression of the result

$$\% \text{ fineness of the sample shown by the sieve, with 0,630 mm apertures} = (50 - M_1) \times 2$$

$$\% \text{ fineness of the sample shown by the sieve, with 0,160 mm apertures} = [50 - (M_1 + M_2)] \times 2$$

where

M_1 = mass, in grams, of residue on the sieve, with 0,630 mm apertures,

M_2 = mass, in grams, of residue on the sieve, with 0,160 mm apertures.

The reject from the sieve, with 0,630 mm apertures having been already eliminated.

The results of these calculations are rounded up to the nearest unit.

Method 7.2

Determination of the fineness of grinding of soft natural phosphates

1. Scope

This Method is for determining the fineness of grinding of soft natural phosphates.

2. Field of application

Soft natural phosphates.

3. Principle

For samples of fine particle size, agglomeration may occur thus making dry sieving difficult. For this reason, wet sieving is normally used.

4. Reagents

Sodium hexametaphosphate solution: 1 %.

5. Apparatus

- 5.1. Sieves with apertures of 0,063 and 0,125 mm respectively of standard ranges (diameter 20 cm and height 5 cm); collecting containers
- 5.2. Glass funnel of 20 cm diameter mounted on a stand
- 5.3. 250-ml beakers
- 5.4. Drying oven

6. Method of analysis

6.1. Sampling

Weigh, to the nearest 0,05 g, 50 g of the substance. Wash both sides of the sieve with water and place the sieve with 0,125 mm apertures above the 0,063 mm sieve.

6.2. Procedure

Place the sample for analysis on the top sieve. Sieve under a small jet of cold water (tap water can be used) until the water is practically clear when it passes through. Care should be taken to ensure that the flow of water is such that the lower sieve never fills with water.

When the residue on the top sieve seems to remain more or less constant, remove this sieve, and place, in the meanwhile on a collecting container.

Continue the wet sieving through the lower sieve for a few minutes, until the water passing through is nearly clear.

Replace the 0,125 mm sieve over the 0,063 mm sieve. Transfer any deposit from the collecting container to the top sieve and begin sieving again under a small jet of water until this water becomes almost clear once more.

Quantitatively transfer each of the residues into a different beaker by means of the funnel. Suspend each residue by filling the beakers with water. Leave to stand for about one minute, decant, as much water as possible.

Place the beakers in the drying oven at 150 °C for two hours.

Allow them to cool, detach the residues with a brush and weigh them.

7. **Expression of the result**

The results of the calculations are rounded up to the nearest unit.

$$\% \text{ fineness shown by the residue left on the 0,125 mm sieve} = (50 - M_1) \times 2$$

$$\% \text{ fineness shown by the residue left on the 0,063 mm sieve} = [50 - (M_1 + M_2)] \times 2$$

where

M_1 = mass, in grams, of the residue on the 0,125 mm sieve,

M_2 = mass, in grams, of the residue on the 0,063 mm sieve.

8. **Remarks**

If the presence of lumps is observed after sieving the analysis should be carried out again in the following way.

Slowly pour 50 g of the sample into a one-litre flask containing 500 ml of the sodium hexametaphosphate solution stirring continuously. Stopper the flask and shake vigorously by hand to break up the lumps. Transfer the whole suspension into the top sieve and wash the flask thoroughly. Continue the analysis as described in 6.2.

Methods 8

Secondary nutrients

Method 8.1

Extraction of total calcium, total magnesium, total sodium and total sulphur in the form of sulphates

1. **Scope**

This document defines the procedure for extracting total calcium, total magnesium and total sodium, and for extracting the total sulphur present in the form of sulphates, so that the same extract may be used for the determination of each nutrient required.

2. **Field of application**

This Method applies to EC fertilisers, for which a declaration of the total calcium, total magnesium, total sodium, and total sulphur in the form of sulphates is provided for in this Regulation.

3. **Principle**

Solubilisation by boiling in dilute hydrochloric acid.

4. **Reagents**

4.1. *Diluted hydrochloric acid*

One volume of hydrochloric acid ($d_{20} = 1,18 \text{ g/ml}$) plus one volume of water.

5. **Apparatus**

Electric hot plate with adjustable temperature.

6. **Preparation of the sample**

See Method 1.

7. Procedure**7.1. Test sample**

Calcium, magnesium, sodium and sulphur in the form of sulphates are extracted from a test sample of five grams weighed to within one milligram.

However, when the fertiliser contains more than 15 % of sulphur (S) i.e. 37,5 % SO₃, and more than 18,8 % of calcium (Ca) i.e. 26,3 % CaO, the extraction of calcium and sulphur is carried out on a test sample of one gram, weighed to within one milligram. Place the test sample in a 600 millilitre beaker.

7.2. Preparation of the solution

Add approximately 400 millilitres of water and, taking care when the sample contains a significant quantity of carbonates, 50 millilitres of dilute hydrochloric acid (4.1) a small amount at a time. Bring to the boil and maintain for 30 minutes. Allow to cool, stirring occasionally. Decant quantitatively into a 500 millilitre graduated flask. Make up to volume with water, and mix. Pass through a dry filter into a dry container, discarding the initial portion. The extract must be completely transparent. Stopper if the filtrate is not used immediately.

Method 8.2**Extraction of total sulphur present in various forms****1. Scope**

This document defines the procedure for extracting the total sulphur contained in fertilisers in elemental form and/or in other chemical combinations.

2. Field of application

This Method applies to EC fertilisers for which a declaration of the total sulphur present in various forms (elemental, thiosulphate, sulphite, sulphate) is provided for in this Regulation.

3. Principle

Elemental sulphur is converted in an alkaline medium into polysulphides and thiosulphate; these, together with any sulphites which may be present, are then oxidised with hydrogen peroxide. The various forms of sulphur are thus converted into sulphate which is determined by precipitation of barium sulphate (Method 8.9).

4. Reagents**4.1. Diluted hydrochloric acid:**

One volume of hydrochloric acid (d = 1,18) plus one volume of water.

4.2. Sodium hydroxide solution, NaOH, 30 % minimum (d = 1,33)**4.3. Hydrogen peroxide solution, 30 % w/w****4.4. Aqueous solution of barium chloride BaCl₂ · 2H₂O, 122 grams per litre****5. Apparatus**

Electric hot plate with adjustable temperature.

6. Preparation of the sample

See Method 1.

7. Procedure**7.1. Test sample**

Weigh out to within one milligram a quantity of fertiliser containing between 80 and 350 milligrams of sulphur (S) or 200 and 875 milligrams of SO₃.

As a rule (where S < 15 %), weigh out 2,5 grams. Place the test sample in a 400 millilitre beaker.

7.2. *Oxidation*

Add 20 millilitres of sodium hydroxide solution (4.2) and 20 millilitres of water. Cover with a watch glass. Boil for five minutes on the hot plate (5.1). Remove from the hot plate. Using a jet of hot water, collect the sulphur sticking to the sides of the beaker and boil for 20 minutes. Leave to cool.

Add 2 millilitre increments of hydrogen peroxide (4.3) until no reaction is observed. Six to eight ml of hydrogen peroxide will be necessary. Allow oxidation to continue for one hour, then bring to the boil for half an hour. Leave to cool.

7.3. *Preparation of the solution to be analysed*

Add approximately 50 millilitres of water and 50 millilitres of the hydrochloric acid solution (4.1).

— If the level of sulphur (S) is less than 5%:

filter into a 600 millilitre beaker. Wash the residue on the filter several times with cold water. After washing, check for the absence of sulphate in the last drops of the filtrate using a barium chloride solution (4.4). The filtrate must be perfectly clear. Sulphate is determined on the whole of the filtrate in accordance with Method 8.9.

— If the level of sulphur (S) is at above 5%:

transfer quantitatively into a 250 millilitre volumetric flask, make up to volume with water and mix. Filter through a dry filter into a dry container; the filtrate must be completely clear. Stopper if the solution is not to be used immediately. Determine sulphates on an aliquot of this solution by precipitation in the form of barium sulphate (Method 8.9).

Method 8.3

**Extraction of water-soluble calcium, magnesium, sodium and sulphur
(in the form of sulphates)**1. **Scope**

This document defines the procedure for extracting water-soluble calcium, magnesium, sodium and sulphur (in the form of sulphates), so that the same extract can be used to determine each nutrient required.

2. **Field of application**

This Method applies solely to fertilisers for which a declaration of the water soluble calcium, magnesium, sodium and sulphur (in the form of sulphates) is provided for in Annex I.

3. **Principle**

The nutrients are solubilised in boiling water.

4. **Reagents**

Distilled or demineralised water of equivalent quality.

5. **Apparatus**

Electric hot plate with adjustable temperature.

6. **Preparation of the sample**

See Method 1.

7. **Procedure**7.1. *Test sample*

(a) Where fertilisers contain no sulphur or where they contain, at the same time, no more than 3% of the sulphur (S) i.e. 7,5% SO₃ and no more than 4% of calcium (Ca) i.e. 5,6% CaO, weigh out five grams of fertiliser to within one milligram.

(b) Where fertilisers contain more than 3 % of sulphur (S) and more than 4 % of calcium (Ca), weigh out one gram of fertiliser to within one milligram.

Place the test sample in a 600 millilitre beaker.

7.2. *Preparation of the solution*

Add approximately 400 millilitres of water and boil for 30 minutes. Allow to cool, stirring occasionally, and decant quantitatively into a 500 millilitre graduated flask. Make up to volume with water and mix.

Filter through a dry filter into a dry container. Discard the initial portions of the filtrate. The filtrate must be completely transparent.

Stopper if the solution is not to be used immediately.

Method 8.4

Extraction of water-soluble sulphur where the sulphur is in various forms

1. **Scope**

This document defines the procedure for extracting the water-soluble sulphur contained in fertilisers in various forms.

2. **Field of application**

This Method applies to fertilisers for which a declaration of the water-soluble sulphur trioxide is provided for in Annex I.

3. **Principle**

The sulphur is dissolved in cold water and converted into sulphate by oxidation with hydrogen peroxide in an alkaline medium.

4. **Reagents**

4.1. *Diluted hydrochloric acid*

One volume of hydrochloric acid ($d_{20} = 1,18$ g/ml) plus one volume of water.

4.2. Sodium hydroxide solution containing at least 30 % NaOH ($d_{20} = 1,33$ g/ml)

4.3. Hydrogen peroxide solution, 30 % w/w

5. **Apparatus**

5.1. 500 millilitre graduated Stohmann flask

5.2. Rotary shaker, 30 to 40 turns per minute

5.3. Electric hot plate with adjustable temperature

6. **Preparation of the sample**

See Method 1.

7. **Procedure**

7.1. *Test sample*

(a) Where fertilisers contain a maximum of 3 % of sulphur (S) i.e. 7,5 % SO_3 , together with a maximum of 4 % of calcium (Ca) i.e. 5,6 % CaO, weigh out 5 grams of fertiliser to within one milligram.

(b) Where fertilisers contain more than 3 % of sulphur (S) and more than 4 % of calcium (Ca), weigh out one gram of fertiliser to within one milligram.

Place the test sample in a 500 millilitre flask (5.1).

7.2. *Preparation of the solution*

Add approximately 400 millilitres of water. Stopper. Shake (5.2) for 30 minutes. Make up to volume with water and mix. Pass through a dry filter into a dry container. Stopper if the solution is not to be used immediately.

7.3. *Oxidation of the aliquot portion to be analysed*

Take an aliquot portion of the extraction solution not exceeding 50 millilitres and, if possible, containing between 20 and 100 milligrams of sulphur (S).

Make up the volume to 50 millilitres with water, if necessary. Add three millilitres of sodium hydroxide solution (4.2) and two millilitres of hydrogen peroxide solution (4.3). Cover with a watch glass and boil gently for one hour on the hot plate (5.3). Keep adding one millilitre increments of hydrogen peroxide solution for as long as the reaction continues (maximum quantity five millilitres).

Then leave to cool. Remove the watch glass and wash the underside into the beaker. Add approximately 20 millilitres of dilute hydrochloric acid (4.1). Make up to approximately 300 millilitres with water.

Determine the content of sulphates on the whole of the oxidised solution in accordance with Method 8.9.

Method 8.5

Extraction and determination of elemental sulphur

Warning

This Method of analysis involves the use of carbon disulphide (CS₂). Special safety measures must therefore be taken, in particular with regard to:

- the storage of CS₂,
- protective equipment for staff,
- occupational hygiene,
- prevention of fires and explosions,
- disposal of the reagent.

This Method requires a highly skilled staff and a suitably equipped laboratory.

1. **Scope**

This defines the procedure for extracting and determining the elemental sulphur contained in fertilisers.

2. **Field of application**

This Method applies to EC fertilisers for which a declaration of the total sulphur in elemental form is provided for in Annex I.

3. **Principle**

After the removal of soluble compounds, elemental sulphur is extracted by using carbon disulphide, followed by gravimetric determination of the sulphur extracted.

4. **Reagents**

Carbon disulphide.

5. **Apparatus**

- 5.1. 100 millilitre extraction flask with ground glass stopper
- 5.2. Soxhlet apparatus, with the appropriate filter elements
- 5.3. Vacuum rotary evaporator
- 5.4. Electric oven, fan assisted, set at 90 (± 2) °C

- 5.5. Porcelain petri dishes, five to seven centimetres in diameter, not exceeding five centimetres in height
- 5.6. Electric hot plate with adjustable temperature
6. **Preparation of the sample**
- See Method 1.
7. **Procedure**
- 7.1. *Test sample*
- Weigh out five to ten grams of the sample to an accuracy of one milligram and place in the thimble of the Soxhlet apparatus (5.2).
- 7.2. *Extraction of the sulphur*
- Wash thoroughly the contents with hot water to remove all soluble compounds. Dry in the oven at 90 °C (5.4) for at least one hour. Place the filter in the Soxhlet apparatus (5.2).
- Place a few glass beads in the flask of the apparatus (5.1) and weigh (P_0), then add 50 millilitres of carbon disulphide (4.1).
- Connect the apparatus and leave the elemental sulphur to be extracted for six hours. Switch off the heat and, after cooling, disconnect the flask. Connect the flask to the rotary evaporator (5.3) and evaporate until the contents of the flask have solidified in a spongy mass.
- Dry the flask in the oven at 90 °C (5.4) (generally one hour is necessary) until a constant mass is obtained (P_1).
- 7.3. *Determination of the purity of the elemental sulphur*
- Certain substances may have been extracted by the carbon disulphide at the same time as the elemental sulphur. The purity of the elemental sulphur is determined as follows:
- homogenise the contents of the flask as thoroughly as possible, and remove two or three grams, weighed to an accuracy of one milligram (n). Place in the Petri dish (5.5). Weigh dish and contents together (P_2). Place on the hot plate (5.6) set at a temperature not exceeding 220 °C so as not to cause combustion of the sulphur. Continue sublimation for three or four hours until a constant mass is obtained (P_3).
- Note
- For some fertilisers, it may not be necessary to determine how pure the sulphur is. In this case, omit step 7.2.
8. **Expression of results**
- The percentage elemental sulphur (S) content of the fertiliser is as follows:

$$\text{Impure S (\% of the fertiliser)} = \frac{P_1 - P_0}{m} \times 100$$

$$\text{Purity of sulphur extracted (\%)} = \frac{P_2 - P_1}{n} \times 100$$

$$\text{Pure S (\% of the fertiliser)} = \frac{(P_1 - P_0)(P_2 - P_3)}{m \times n} \times 100$$

Where

m = the mass of the test sample of fertiliser in grams,

P_0 = the mass of the Soxhlet flask in grams,

P_1 = the mass of the Soxhlet flask and the impure sulphur after drying,

n = the mass of the impure sulphur to be purified in grams,

P_2 = the mass of the Petri dish,

P_3 = the mass of the Petri dish after sublimation of the sulphur in grams.

Method 8.6

Manganimetric determination of extracted calcium following precipitation in the form of oxalate**1. Scope**

This document defines the procedure for determining the calcium in fertiliser extracts.

2. Field of application

This Method applies to EC fertilisers for which a declaration of the total and/or water-soluble calcium is provided for in Annex I.

3. Principle

Precipitation of the calcium contained in an aliquot of the extraction solution in the form of an oxalate, which is determined by titration using potassium permanganate.

4. Reagents4.1. *Diluted hydrochloric acid*

One volume of hydrochloric acid ($d_{20} = 1,18$ g/ml) and one volume of water.

4.2. *1:10 dilute sulphuric acid*

One volume of sulphuric acid ($d_{20} = 1,84$ g/ml) in ten volumes of water.

4.3. *1:1 dilute ammonia solution*

One volume of ammonia ($d_{20} = 0,88$ g/ml) and one volume of water.

4.4. Saturated solution of ammonia oxalate $[(\text{NH}_4)_2\text{C}_2\text{O}_4 \cdot \text{H}_2\text{O}]$ at ambient temperature (approximately 40 grams per litre)

4.5. Citric acid solution, 30 % (m/v)

4.6. Ammonium chloride solution, 5 % (m/v)

4.7. Solution of bromothymol blue in ethanol, at 95 %, 0,1 % (m/v)

4.8. Solution of bromocresol green in ethanol, at 95 %, 0,04 % (m/v)

4.9. Standard solution of potassium permanganate, 0,02 mol/l

5. Apparatus5.1. Filter crucible with 5 to 20 μ porosity sintered glass

5.2. Hot water bath

6. Preparation of the aliquot to be analysed

Using a pipette, take an aliquot portion of the extraction solution obtained by Method 8.1 or 8.3, containing between 15 and 50 milligrams of Ca (= 21 to 70 milligrams of CaO). Let the volume of this aliquot be v_2 . Pour into a 400 millilitre beaker. If necessary, neutralise (turning of indicator (4.7) from green to blue) with a few drops of the ammonia solution (4.3).

Add one millilitre of the citric acid solution (4.5) and five millilitres of ammonium chloride solution (4.6).

7. Precipitation of the calcium oxalate

Add approximately 100 millilitres of water. Bring to the boil, add eight to ten drops of indicator solution (4.8) and, slowly, 50 millilitres of a hot ammonium oxalate solution (4.4). If a precipitate forms, dissolve by adding a few drops of hydrochloric acid (4.1). Neutralise very slowly with ammonia solution (4.3) while stirring continuously to a pH of 4,4 to 4,6 (turning of indicator (4.8) from green to blue). Place the beaker in a boiling hot water bath (5.2) for approximately 30 minutes.

Remove the beaker from the bath, leave standing for an hour and filter into the crucible (5.1).

8. **Titration of the oxalate precipitate**

Wash the beaker and crucible until the excess ammonium oxalate has been completely removed (this can be checked by the absence of chloride in the washing water). Place the crucible in the 400 millilitre beaker and dissolve the precipitate with 50 millilitres of hot sulphuric acid (4.2). Add water to the beaker in order to obtain a volume of approximately 100 millilitres. Bring to a temperature of 70 to 80 °C and titrate drop by drop with a permanganate solution (4.9) until the pink colour lasts for a minute. Let this volume be n .

9. **Expression of results**

The calcium (Ca) content of the fertiliser is as follows:

$$\text{Ca (\%)} = n \times 0,2004 \times \frac{t}{0,02} \times \frac{v_1}{v_2 \times m}$$

Where

n = the number of millilitres of permanganate used,

m = the mass of the test sample in grams,

v_2 = the aliquot volume in millilitres,

v_1 = the volume of the extraction solution in millilitres,

t = the concentration of the permanganate solution in moles per litre.

$\text{CaO (\%)} = \text{Ca (\%)} \times 1,400$

Method 8.7

Determination of magnesium by atomic absorption spectrometry

1. **Scope**

This document defines the procedure for determining the magnesium in fertiliser extracts.

2. **Field of application**

This Method applies to EC fertiliser extracts obtained by methods 8.1 and 8.3, for which a declaration of the total magnesium and/or water soluble magnesium is required, with the exception of the following fertilisers listed in Annex I D relating to secondary nutrients:

- type 4 (kieserite),
- type 5 (magnesium sulphate) and type 5.1 (magnesium sulphate solution),
- and with the exception of the following fertiliser listed in Annex I A 3 relating to potassic fertilisers:
- type 7 (kieserite with potassium sulphate)
- to which Method 8.8 applies.

The Method set out below applies to all fertiliser extracts containing elements in quantities that might interfere with the complexometric determination of magnesium.

3. **Principle**

Determination of magnesium by atomic absorption spectrometry after appropriate dilution of the extract.

4. **Reagents**

- 4.1. Hydrochloric acid, 1 mol/l solution
- 4.2. Hydrochloric acid, 0,5 mol/l solution

- 4.3. *Standard solution of magnesium, 1,00 milligrams per millilitre*
- 4.3.1. Dissolve 1,013 grams of magnesium sulphate ($\text{MgSO}_4 \cdot 7\text{H}_2\text{O}$) in the 0,5 mol/l hydrochloric acid solution (4.2)
- 4.3.2. Weigh out 1,658 grams of magnesium oxide (MgO), previously calcined to remove all traces of carbonation. Place in a beaker with 100 millilitres of water and 120 millilitres of 1 mol/l hydrochloric acid (4.1). When it has dissolved, decant quantitatively into a 1 000 millilitre graduated flask. Make up the volume by adding and mix
- or
- 4.3.3. Commercial standard solution

The laboratory is responsible for testing such solutions.

- 4.4. *Strontium chloride solution*
- Dissolve 75 grams of strontium chloride ($\text{SrCl}_2 \cdot 6\text{H}_2\text{O}$) in a hydrochloric acid solution (4.2) and make up to 500 millilitres with the same acid solution.

5. **Apparatus**

Spectrometer fitted for atomic absorption, with a magnesium lamp, set at 285,2 nm.

Air-acetylene flame.

6. **Preparation of the sample**

See Methods 8.1 and 8.3.

7. **Procedure**

- 7.1. If the fertiliser has a declared magnesium (Mg) content of more than 6 % (i.e. 10 % as MgO), take 25 millilitres (V_1) of the extraction solution (6). Transfer into a 100 millilitre graduated flask, and make up to volume with water and mix. The dilution factor is $D_1 = 100/V_1$
- 7.2. Using a pipette, take 10 millilitres of the extraction solution (6) or the solution (7.1). Transfer into a 200 millilitre graduated flask. Make up to volume with the 0,5 mol/l hydrochloric acid solution (4.2) and mix. The dilution factor is 200/10
- 7.3. Dilute this solution (7.2) with the 0,5 mol/l hydrochloric acid solution (4.2) so as to obtain a concentration in the optimum working field of the spectrometer (5.1). V_2 is the volume of the sample in 100 millilitres. The dilution factor is $D_2 = 100/V_2$

The final solution should contain 10 % v/v of the strontium chloride solution (4.4).

7.4. *Preparation of blank solution*

Prepare a blank solution by repeating the whole procedure from the extraction (Method 8.1 or 8.3), omitting only the test sample of fertiliser.

7.5. *Preparation of calibration solutions*

By diluting the standard solution (4.3) with the 0,5 mol/l hydrochloric acid, prepared at least five calibration solutions of increasing concentration within the optimum measuring range of the apparatus (5.1).

These solutions should contain 10 % v/v of the strontium chloride solution (4.4).

7.6. *Measurement*

Set up the spectrometer (5.1) at a wavelength of 285,2 nm.

Spray, successively, the calibration solutions (7.5), the sample solution (7.3) and the blank solution (7.4), washing the instrument through with the solution to be measured next. Repeat this operation three times. Plot the calibration curve using the mean absorbancies of each of the calibrations (7.5) as the ordinates and the corresponding concentration of magnesium in $\mu\text{g/ml}$ as the abscissae. Determine the concentration of magnesium in the sample (7.3), X_s and blank (7.4), X_b , by reference to the calibration curve.

8. Expression of results

Calculate the amount of magnesium (Mg) or magnesium oxide (MgO) in the sample by reference to the calibration solutions and taking into consideration the blank.

The percentage of magnesium (Mg) in the fertiliser is equal to:

$$\text{Mg (\%)} = \frac{(X_s - X_b) D_1 (200/10) D_2 500,100}{1000.1000 M}$$

Where

X_s = the concentration of the solution to be analysed recorded on the calibration curve, in $\mu\text{g/ml}$.

X_b = the concentration of the blank solution as recorded on the calibration curve, in $\mu\text{g/ml}$.

D_1 = the dilution factor when the solution is diluted (7.1).

— It is equal to four if 25 millilitres are taken.

— It is equal to one when the solution is not diluted.

— D_2 = the dilution factor is 7.3.

— M = the mass of the test sample at the time of extraction.

— $\text{MgO (\%)} = \text{Mg (\%)} / 0,6$

Method 8.8

Determination of magnesium by complexometry

1. Scope

This document defines the procedure for the determination of magnesium in fertiliser extracts.

2. Field of application

This Method applies to the following EC fertiliser extracts for which the determination of total magnesium and/or water-soluble magnesium is provided for:

— fertilisers listed in Annex I: straight nitrogenous fertilisers, type 1b + 1c (calcium magnesium nitrate), type 7 (magnesium sulphonitrate), type 8 (nitrogenous fertilisers with magnesium) and straight potassic fertilisers, type 2 (enriched kainite), type 4 (potassium chloride containing magnesium), type 6 (potassium sulphate containing magnesium salt),

— fertilisers listed in the Annex I D relating to secondary nutrients.

3. Principle

The magnesium is solubilised by methods 8.1 and/or 8.3. First titration: with EDTA of Ca and Mg in the presence of Eriochrome black-T. Second titration: with EDTA of Ca in the presence of calcein or of calcon carbonic acid. Determination of magnesium by difference.

4. Reagents

4.1. Standard 0,05 mol/l solution of magnesium:

4.1.1. Dissolve 1,232 grams of magnesium sulphate ($\text{MgSO}_4 \cdot 7\text{H}_2\text{O}$) in the 0,5 mol/l hydrochloric acid solution (4.11) and make up to 100 millilitres with the same acid

or

4.1.2. Weigh out 2,016 grams of magnesium oxide, previously calcined to remove all traces of carbonation. Place it in a beaker with 100 millilitres of water

Stir in approximately 120 millilitres of approximately 1 mol/l hydrochloric acid (4.12).

After dissolution, transfer quantitatively into a graduated 1 000 millilitre flask. Make up to volume and mix.

One millilitre of these solutions should contain 1,216 milligrams of Mg (= 2,016 milligrams of MgO).

The laboratory is responsible for testing the strength of this standard solution.

4.2. *0,05 molar solution of EDTA*

Weigh out 18,61 grams of the dihydrated disodium salt of ethylenediaminetetraacetic ($C_{10}H_{14}N_2Na_2O_8 \cdot 2H_2O$), place it in a 1 000 millilitre beaker and dissolve in 600 to 800 millilitres of water. Transfer the solution quantitatively into a graduated 1 000 millilitre flask. Make up the volume and mix. Check this solution with the standard solution (4.1) by taking a sample of 20 millilitres of the latter and by titration according to the analytical procedure described at (7.2).

One millilitre of the EDTA solution should correspond to 1,216 milligrams of Mg (= 2,016 milligrams of MgO) and to 2,004 milligrams of Ca (= 2,804 milligrams CaO) (see remarks 10,1 and 10,6).

4.3. *0,05 molar standard solution of calcium*

Weigh out 5,004 grams of dry calcium carbonate. Place it in a beaker with 100 millilitres of water. Progressively stir in 120 millilitres of approximately 1 mol/l hydrochloric acid (4.12).

Bring to the boil in order to drive off the carbon dioxide, cool, transfer quantitatively into a graduated one-litre flask, make up the volume with water and mix. Check this solution against the EDTA solution (4.2) following analytical procedure (7.3). One millilitre of this solution should contain 2,004 milligrams of Ca (= 2,804 milligrams of CaO) and should correspond to one millilitre of the 0,05 molar EDTA solution (4.2).

4.4. *Calcein indicator*

Carefully mix in a mortar one gram of calcein with 100 grams of sodium chloride. Use 10 milligrams of this mixture. The indicator changes from green to orange. Titration must be carried out until an orange is obtained which is free from green tinges.

4.5. *Calcon carbonic acid indicator*

Dissolve 400 milligrams of calcon carbonic acid in 100 millilitres of methanol. This solution may only be kept for approximately four weeks. Use three drops of this solution. The indicator changes from red to blue. Titration must be carried out until a blue is obtained which is free from red tinges.

4.6. *Eriochrome black-T indicator*

Dissolve 300 milligrams of Eriochrome black-T in a mixture of 25 millilitres of propanol-1 and 15 millilitres of triethanolamine. This solution may only be kept for approximately four weeks. Use three drops of this solution. This indicator turns from red to blue and titration must be carried out until a blue is obtained which is free from red tinges. It changes colour only when magnesium is present. If necessary add one millilitre of the standard solution (4.1).

When both calcium and magnesium are present the EDTA first forms a complex with the calcium and then with the magnesium. In that case two elements are determined concurrently.

4.7. *Potassium cyanide solution*

Aqueous solution of KCN at 2 %. (Do not pipette by mouth and see 10.7).

4.8. *Solution of potassium hydroxide and potassium cyanide*

Dissolve 280 grams of KOH and 66 grams of KCN in water, make up the volume to one litre and mix.

4.9. *pH 10,5 buffer solution*

In a 500 millilitre graduated flask, dissolve 33 grams of ammonium chloride in 200 millilitres of water, add 250 millilitres of ammonia ($d_{20} = 0,91$ g/ml) make up the volume with water and mix. Test the pH of the solution regularly.

4.10. *Diluted hydrochloric acid: one volume of hydrochloric acid ($d_{20} = 1,18$ g/ml) plus one volume of water*

4.11. *Hydrochloric acid solution approximately 0,5 mol/l*

4.12. *Hydrochloric acid solution approximately 1 mol/l*

4.13. *Sodium hydroxide solution 5 mol/l*

5. **Apparatus**

- 5.1. Magnetic or mechanical stirrer
- 5.2. pH meter

6. **Control test**

Carry out a determination on aliquot parts of solutions (4.1 and 4.3) such that the Ca/Mg ratio is approximately equal to that of the solution to be analysed. To this end take (a) millilitres of Mg standard solution (4.3) and (b-a) millilitres of standard solution (4.1) (a) and (b) are the numbers of millilitre EDTA solution used in the two titrations performed on the solution to be analysed. This procedure is correct only if the solutions of EDTA, calcium and magnesium are exactly equivalent. If this is not the case, it is necessary to make corrections.

7. **Preparation of the solution to be analysed**

See methods 8.1 and 8.3.

8. **Determination**

8.1. *Aliquot samples to be taken*

The aliquot part will as far as possible contain between 9 and 18 milligrams of magnesium (= 15 to 30 milligrams of MgO).

8.2. *Titration in the presence of Eriochrome black-T*

Pipette an aliquot part (8.1) of the solution to be analysed into a 400 millilitre beaker. Neutralise the surplus acid with the 5 mol/l sodium hydroxide solution (4.12) using the pH meter. Dilute with water to approximately 100 millilitres. Add 5 millilitres of the buffer solution (4.9). The pH measured by the meter must be $10,5 \pm 0,1$. Add 2 millilitres of the potassium cyanide solution (4.7) and three drops of the Eriochrome black-T indicator (4.6). Titrate with the EDTA solution (4.2). Stirring gently with the stirrer (5.1) (see 10,2, 10,3 and 10,4). Let 'b' be the number of millilitres of 0,05 mol/l EDTA solution.

8.3. *Titration in the presence of calcein or of calcon carbonic acid*

Pipette an aliquot part of the solution to be analysed equal to that taken from the above titration and place it in a 400 millilitre beaker. Neutralise the surplus acid with the 5 mol/l sodium hydroxide solution (4.13) using the pH meter. Dilute with water to about 100 millilitres. Add 10 millilitres of the KOH/KCN solution (4.8) and the indicator (4.4 or 4.5). Stirring gently with the stirrer (5.1) titrate with the EDTA solution (4.2) (see 10,2, 10,3 and 10,4). Let 'a' be the number of millilitres of 0,05 mol/l EDTA solution.

9. **Expression of the results**

For the EC fertilisers to which the Method is applicable (5 grams of fertiliser in 500 millilitres of extract), the percentage content of the fertiliser is:

$$\text{MgO (\% in the fertiliser)} = \frac{(b - a) \times T}{M}$$

$$\text{Mg (\% in the fertiliser)} = \frac{(b - a) \times T'}{M}$$

Where

a = the number of millilitres of 0,05 mol/l EDTA solution used for the titration in the presence of calcein or calcon carbonic acid,

b = the number of millilitres of 0,05 mol/l EDTA solution used for the titration in the presence of Eriochrome black-T,

M = the mass of the sample present in the aliquot part taken (in grams),

T = $0,2016 \times \text{mol/l}$ of the EDTA solution/0,05 (see 4.2),

T' = $0,1216 \times \text{mol/l}$ of the EDTA solution/0,05 (see 4.2).

10. **Remarks**
- 10.1. The stoichiometric EDTA-metal ratio in the complexometric analyses is always 1:1 whatever the valency of the metal and in spite of the fact that EDTA is quadrivalent. The EDTA titration solution and the standard solutions will therefore be molar and not normal
- 10.2. Complexometric indicators are often sensitive to air. The solution may lose colour during titration. In this case, one or two drops of indicator must be added. This is true particularly in the case of eriochrome black and calcon carbonic acid
- 10.3. The metal-indicator complexes are often relatively stable and it may take some time for the colour to change. The last drops of EDTA must therefore be added slowly and a drop of 0,05 mol/l solution of magnesium (4.1) or calcium (4.3) added to ensure that the colour change has not already taken place. This is particularly true in the case of the eriochrome-magnesium complex
- 10.4. The turning of the indicator must be observed not vertically, but horizontally across the solution and the beaker must be placed against a white background in a well-lit position. The turning of the indicator may also be observed easily by placing the beaker on frosted glass lit moderately from below (25 watt lamp)
- 10.5. This analysis requires a certain amount of experience. The task will involve, *inter alia*, observing the colour changes of standard solutions 4.1 and 4.3. It is recommended that the determinations be carried out by the same laboratory chemist
- 10.6. If an EDTA solution of guaranteed strength is used (Titrisol, Normex, for example) this may simplify the control of the equivalence of standard solutions 4.1, 4.2 and 4.3
- 10.7. The solutions containing potassium cyanide must not be poured down the sink until the cyanide has been converted into a harmless compound, for example, by oxidization with sodium hypochlorite following alkalisation

Method 8.9

Determination of sulphates

1. **Scope**
- This document defines the procedure for determining the sulphur present in fertiliser extracts in the form of sulphates.
2. **Field of application**
- This Method applies to the determination of sulphates present in the extractions performed in methods 8.1, 8.2, 8.3 and 8.4.
3. **Principle**
- Gravimetric determination as barium sulphate.
4. **Reagents**
- 4.1. *Diluted hydrochloric acid*
- One volume of hydrochloric acid ($d_{20} = 1,18$ g/ml) and one volume of water.
- 4.2. Barium chloride solution $\text{BaCl}_2 \cdot 2\text{H}_2\text{O}$: 122 grams per litre
- 4.3. Silver nitrate solution: 5 grams per litre
5. **Apparatus**
- 5.1. Porcelain crucibles
- 5.2. Hot water bath
- 5.3. Drying oven set at 105 °C (± 1) °C
- 5.4. Electric oven set at 800 °C (± 50) °C

6. Procedure**6.1. Sampling of the solution**

Pipette an aliquot part of one of the extraction solutions indicated at 2 containing between 20 and 100 milligrams of S or 50 and 250 milligrams of SO₃.

Place this aliquot in a beaker of suitable capacity. Add 20 millilitres of dilute hydrochloric acid (4.1). Make up to about 300 millilitres with water.

6.2. Preparation of the precipitate

Bring the solution to the boil. Add, drop by drop, about 20 millilitres of the barium chloride solution (4.2) while stirring the solution vigorously. Boil for a few minutes.

Place the beaker, covered with a watch glass, in a boiling hot water bath (5.2) for an hour. Then leave standing hot (about 60 °C) until the supernatant liquor is clear. Decant the clear solution through a slow filtration ash-free filter. Wash the precipitate several times with hot water. Continue to wash the precipitate on the filter until the filtrate is chloride free. This can be checked by using silver nitrate solution (4.3).

6.3. Incineration and weighing of the precipitate

Place the filter paper and precipitate in a porcelain crucible (5.1) previously weighed to the nearest 0,1 milligrams. Dry in the oven (5.3) and ash at approximately 800 °C for half an hour (5.4). Allow to cool in a desiccator and weigh to within 0,1 milligrams.

7. Expression of the results

One milligram of barium sulphate corresponds to 0,137 milligrams of S or to 0,343 milligrams of SO₃.

The percentage S content of the fertiliser is as follows:

$$S (\%) = w \times 0,0137 \times \frac{v_1}{v_2 \times m}$$

$$SO_3 (\%) = S (\%) \times 2,5$$

Where

w = the mass of the barium sulphate precipitate in milligrams,

v₁ = the volume of the extraction solution in millilitres,

v₂ = the aliquot volume in millilitres,

m = the mass of the test sample in grams.

Method 8.10**Determination of the sodium extracted****1. Scope**

This document defines the procedure for determining the sodium in fertiliser extracts.

2. Field of application

This Method applies to EC fertilisers for which a declaration of the sodium is provided for in Annex I.

3. Principle

Following suitable dilution of the extract obtained via Method 8.1 and/or 8.3, the sodium content of the solution is determined by flame-emission spectrometry.

4. Reagents

4.1. Diluted hydrochloric acid

One volume of hydrochloric acid for analysis ($d_{20} = 1,18 \text{ g/ml}$) plus one volume of water.

4.2. Aluminium nitrate $\text{Al}(\text{NO}_3)_3 \cdot 9\text{H}_2\text{O}$

4.3. Caesium chloride, CsCl

4.4. Anhydrous sodium chloride, NaCl

4.5. Caesium chloride and aluminium nitrate solution

Dissolve in water 50 grams of caesium chloride (4.3) and 250 grams of aluminium nitrate (4.2) in a 1 000 millilitre graduated flask. Make up to volume with water and mix.

4.6. Standard sodium solution of one milligram/millilitre of Na

Dissolve in water 2,542 grams of sodium chloride (4.4) in a 1 000 millilitre graduated flask. Add 10 millilitres of hydrochloric acid (4.1). Make up to volume with water and mix.

5. Apparatus

Spectrometer equipped for flame emission, set at 589,3 nm.

6. Calibration solutions

6.1. Place 10 millilitres of standard solution (4.6) in a 250 millilitre graduated flask. Make up to volume and mix. Concentration of solution: 40 $\mu\text{g/ml}$ of Na

6.2. Place 0, 5, 10, 15, 20, 25 millilitres of the intermediate solution (6.1) in 100 millilitre graduated flasks. Add 10 millilitres of the solution (4.5). Make up to volume and mix. Concentration of solutions: 0, 2, 4, 6, 8, 10 $\mu\text{g/ml}$ of Na

7. Preparation of solutions to be measured

Depending upon the expected sodium content of the extraction solution as in Method 8.1 or 8.3 (five grams of fertiliser in 500 millilitres), carry out the dilutions in accordance with the following table:

Na ₂ O (%)	Na (%)	Intermediate dilution		Final dilution		Degree of dilution
		Sample (ml) (v_2)	Dilution to ml (v_3)	Sample (ml) (v_4)	Dilution to ml	
3-5	2,2-3,7	10	50	10	100	50
5-10	3,7-7,4	10	100	10	100	100
10-20	7,4-15	10	100	5	100	200
20-38	15-28	5	100	5	100	400

Make up the intermediate dilution with water. For the final dilution add ten millilitres of the solution (4.5) to the 100 millilitre graduated flask.

For a test sample of one gram multiply the volume of the final dilution (v_4) by five.

8. Determination

Prepare the spectrometer (5.1) for the measurements at 589,3 nm. Calibrate the instrument by measuring the response of the calibration solutions (6.2). Then adjust the sensitivity of the instrument to use its entire scale when the most concentrated calibration solution is used. Then measure the response of the sample solution to be analysed (7). Repeat this operation three times.

9. Calculation of results

Draw a calibration curve by plotting the average response for each calibration solution along the ordinate and the corresponding concentrations, expressed in µg per millilitre on the abscissa. Determine from this the sodium concentration of the test solution. Calculate the quantity of sodium from the standard solutions taking account of the levels of dilution. Express the results as a percentage of the sample.

The percentage sodium (Na) content of the fertiliser is as follows:

$$\text{Na \%} = x \cdot \frac{v_3}{v_4} \frac{v_1}{v_2} \frac{10^{-2}}{m}$$

$$\text{Na}_2\text{O (\%)} = \text{Na (\%)} \times 1,348$$

Where

x = the concentration of the solution introduced into the spectrometer in µg/ml,

v₁ = the volume of the extraction solution in millilitres,

v₂ = the aliquot volume in the intermediate dilution in millilitres,

v₃ = the volume of intermediate dilution in millilitres,

v₄ = the aliquot volume in ml of the final dilution (to 100 millilitres),

m = the mass of the test sample in grams.

Methods 9

Micro-nutrients at a concentration of less than or equal to 10 %

Method 9.1

Extraction of total micro-nutrients

1. Scope

This Method defines the procedure for extracting the following micro-nutrients: total boron, total cobalt, total copper, total iron, total manganese, total molybdenum and total zinc. The aim is to carry out the minimum number of extractions, making use wherever possible of the same extract to determine the total level of each of the micro-nutrients listed above.

2. Field of application

This procedure concerns EC fertilisers covered by Annex I E containing one or more of the following micro-nutrients: boron, cobalt, copper, iron, manganese, molybdenum and zinc. It is applicable to each micro-nutrient the declared content of which is less than or equal to 10 %.

3. Principle

Dissolution in boiling dilute hydrochloric acid.

Note

The extraction is empirical and may not be quantitative depending on the product or the other constituents of the fertiliser. In particular, in the case of certain manganese oxides, the quantity extracted may be substantially smaller than the total quantity of manganese which the product contains. It is the responsibility of the fertiliser manufacturers to ensure that the declared content actually corresponds to the quantity extracted under the conditions pertaining to the method.

4. Reagents

4.1. Dilute hydrochloric acid (HCl) solution, about 6 mol/l

Mix 1 volume of hydrochloric acid ($d_{20} = 1,18$ g/ml) with 1 volume of water.

4.2. Concentrated ammonia solution (NH_4OH , $d_{20} = 0,9$ g/ml)

5. Apparatus

Electric hotplate with variable temperature control.

Note

Where the boron content of an extract is to be determined, do not use borosilicate glassware. As the Method involves boiling, teflon or silica is preferable. Rinse the glassware thoroughly if it has been washed in detergents containing borates.

6. Preparation of the sample

See Method 1.

7. Procedure

7.1. Test sample

Take a quantity of fertiliser weighing between 2 and 10 g depending on the declared content of element in the product. The following table shall be used to obtain a final solution which, after appropriate dilution, will be within the measuring range for each method. Samples should be weighed to within 1 mg.

Declared content of micro-nutrient in the fertiliser (%)	< 0,01	0,01-< 5	$\geq 5-10$
Mass of test sample (g)	10	5	2
Mass of element in the sample (mg)	1	0,5-250	100-200
Volume of extract V (ml)	250	500	500
Concentration of element in extract (mg/l)	4	1-500	200-400

Place the sample in a 250 ml beaker.

7.2. Preparation of the solution

If necessary moisten the sample with a little water, add 10 ml of dilute hydrochloric acid (4.1) per gram of fertiliser carefully, in small amounts, then add about 50 ml of water. Cover the beaker with a watch glass and mix. Bring to the boil on the hotplate and boil for 30 minutes. Allow to cool, stirring occasionally. Transfer quantitatively to a 250 or 500 ml volumetric flask (see Table). Make up to volume with water and mix thoroughly. Filter through a dry filter into a dry container. Discard the first portion. The extract must be perfectly clear.

It is recommended that the determination be carried out without delay on aliquot portions of the clear filtrate, if not the containers should be stoppered.

Remark

Extracts in which the boron content has to be determined: Adjust the pH to between 4 and 6 with concentrated ammonia (4.2).

8. Determination

The determination of each micro-nutrient is to be carried out on the aliquot portions indicated in the Method for each individual micro-nutrient.

If necessary, remove organic chelating or complexing substances from an aliquot portion of the extract by using Method 9.3. In the case of determination by atomic absorption spectrometry, such removal may not be necessary.

Method 9.2

Extraction of water-soluble micro-nutrients**1. Scope**

This Method defines the procedure for extracting water-soluble forms of the following micro-nutrients: boron, cobalt, copper, iron, manganese, molybdenum and zinc. The aim is to carry out the minimum number of extractions, making use wherever possible of the same extract to determine the level of each of the micro-nutrients listed above.

2. Field of application

This procedure concerns EC fertilisers covered by Annex I containing one or more of the following micro-nutrients: boron, cobalt, copper, iron, manganese, molybdenum and zinc. It is applicable to each micro-nutrient the declared content of which is less than or equal to 10 %.

3. Principle

The micro-nutrients are extracted by shaking the fertiliser in water at 20 °C (± 2) °C.

Note

The extraction is empirical and may or may not be quantitative.

4. Reagents**4.1. Dilute hydrochloric acid (HCl) solution, about 6 mol/l**

Mix 1 volume of hydrochloric acid ($d_{20} = 1,18$ g/ml) with 1 volume of water.

5. Apparatus**5.1. Rotary shaker set at about 35 to 40 rpm****5.2. pH-meter****Note**

Where the boron content of the extract is to be determined, do not use borosilicate glassware. Teflon or silica is preferable for this extraction. Rinse the glassware thoroughly if it has been washed in detergents containing borates.

6. Preparation of the sample

See Method 1.

7. Procedure**7.1. Test sample**

Take a quantity of fertiliser weighing between 2 and 10 g depending on the declared content of the element in the product. The following table shall be used to obtain a final solution which, after appropriate dilution, will be within the measuring range for each method. The samples should be weighed to within 1 mg.

Declared content of micro-nutrient in the fertiliser (%)	< 0,01	0,01-< 5	$\geq 5-10$
Mass of test sample (g)	10	5	2
Mass of element in the sample (mg)	1	0,5-250	100-200
Volume of extract V (ml)	250	500	500
Concentration of element in extract (mg/l)	4	1-500	200-400

Place the sample in a 250 or 500 ml flask (according to the Table).

7.2. *Preparation of the solution*

Add about 200 ml of water to the 250 ml flask or 400 ml of water to the 500 ml flask.

Stopper the flask well. Shake vigorously by hand to disperse the sample, then place the flask on the shaker and shake for 30 minutes.

Make up to volume with water and mix thoroughly.

7.3. *Preparation of the test solution*

Filter immediately into a clean, dry flask. Stopper the flask. Carry out the determination immediately after filtering.

Note

If the filtrate gradually becomes cloudy, make another extraction following 7.1 and 7.2 in a flask of volume V_e . Filter into a calibrated flask of volume W which has previously been dried and has received 5,00 ml of dilute hydrochloric acid (4.1). Stop the filtration at the exact moment when the calibration mark is reached. Mix thoroughly.

Under these conditions the value of V in the expression of results is:

$$V = V_e \times W / (W - 5)$$

The dilutions in the expression of results depend on this value of V .

8. **Determination**

The determination of each micro-nutrient is carried out on the aliquot portions indicated in the Method for each individual micro-nutrient.

If necessary, remove organic chelating or complexing substances from an aliquot portion by using Method 9.3. In the case of determination by atomic absorption spectrometry, such removal may not be necessary.

Method 9.3

Removal of organic compounds from fertiliser extracts

1. **Scope**

This Method defines a procedure for removing organic compounds from fertiliser extracts.

2. **Field of application**

This procedure is applicable to analysing samples of fertilisers extracted by Methods 9.1 and 9.2 for which a declaration of total and/or water-soluble element is required by Annex I E to this Regulation.

Note

The presence of small quantities of organic matter usually does not affect determination by means of atomic absorption spectrometry.

3. **Principle**

The organic compounds in an aliquot portion of the extract are oxidised with hydrogen peroxide.

4. **Reagents**

4.1. *Dilute hydrochloric acid (HCl) solution, about 0,5 mol/l*

Mix 1 volume of hydrochloric acid ($d_{20} = 1,18$ g/ml) with 20 volumes of water.

4.2. Hydrogen peroxide solution (30 % H_2O_2 , $d_{20} = 1,11$ g/ml), free from micro-nutrients

5. **Apparatus**

Electric hotplate with variable temperature control.

6. **Procedure**

Take 25 ml of the extract solution obtained by Method 9.1 or Method 9.2 and place in a 100 ml beaker. In the case of Method 9.2, add 5 ml of the dilute hydrochloric acid solution (4.1). Then add 5 ml of the hydrogen peroxide solution (4.2). Cover with a watch glass. Allow oxidation to occur at room temperature for about one hour, then bring gradually to boiling and boil for half an hour. If necessary, add a further 5 ml of the hydrogen peroxide to the solution once it has cooled. Then boil to remove the excess hydrogen peroxide. Allow to cool and transfer quantitatively to a 50 ml volumetric flask and make up to volume. Filter where necessary.

Account should be taken of this dilution when taking aliquot portions and calculating the percentage of micro-nutrient in the product.

Method 9.4

Determination of micro-nutrients in fertiliser extracts by atomic absorption spectrometry (general procedure)

1. **Scope**

This document defines a general procedure for determining the levels of certain micro-nutrients in fertiliser extracts by atomic absorption spectrometry.

2. **Field of application**

This procedure is applicable to analysing samples of fertilisers extracted by Methods 9.1 and 9.2 for which a declaration of total and/or water-soluble element is required by Annex I E to this Regulation.

Adaptations of this procedure for the various micro-nutrients are detailed in the methods defined specifically for each element.

Note

In most cases the presence of small quantities of organic matter will not affect determinations by atomic absorption spectrometry.

3. **Principle**

After the extract has been treated where necessary to reduce or eliminate interfering chemical species, the extract is diluted so that its concentration is in the optimum range of the spectrometer at a wave-length suitable for the micro-nutrient to be determined.

4. **Reagents**

4.1. *Dilute hydrochloric acid solution (HCl), about 6 mol/l:*

Mix one volume of hydrochloric acid ($d_{20} = 1,18$ g/ml) with one volume of water.

4.2. *Dilute hydrochloric acid solution (HCl), about 0,5 mol/l:*

Mix one volume of hydrochloric acid ($d_{20} = 1,18$ g/ml) with 20 volumes of water.

4.3. *Lanthanum salt solutions (10 g of La per litre)*

This reagent is used for determinations of cobalt, iron, manganese and zinc. It can be prepared either:

- (a) with lanthanum oxide dissolved in hydrochloric acid (4.1). Place 11,73 g of lanthanum oxide (La_2O_3) in 150 ml of water in a one litre volumetric flask and add 120 ml of 6 mol/l hydrochloric acid (4.1). Allow to dissolve and then make up to 1 litre with water and mix thoroughly. This solution is approximately 0,5 mol/l in hydrochloric acid

(b) or with solutions of lanthanum chloride, sulphate or nitrate. Dissolve 26,7 g of lanthanum chloride heptahydrate ($\text{LaCl}_3 \cdot 7\text{H}_2\text{O}$) or 31,2 g of lanthanum nitrate hexahydrate [$\text{La}(\text{NO}_3)_3 \cdot 6\text{H}_2\text{O}$] or 26,2 g of lanthanum sulphate nonahydrate [$\text{La}_2(\text{SO}_4)_3 \cdot 9\text{H}_2\text{O}$] in 150 ml of water, then add 85 ml of 6 mol/l hydrochloric acid (4.1). Allow to dissolve and then make up to 1 litre with water. Mix thoroughly. This solution is approximately 0,5 mol/l in hydrochloric acid.

4.4. *Calibration solutions*

For the preparation of these, see the individual determination Method for each micro-nutrient.

5. **Apparatus**

Atomic absorption spectrometer fitted with sources emitting radiation characteristic of the micro-nutrients to be determined.

The analyst must follow the manufacturer's instructions and be familiar with the apparatus. The apparatus must allow background correction so that it can be used whenever necessary (Co and Zn). The gases to be used are air and acetylene.

6. **Preparation of the solution to be analysed**

6.1. *Preparation of extract solutions of the micro-nutrients to be determined.*

See Methods 9.1 and/or 9.2 and, if appropriate, 9.3.

6.2. *Treatment of the test solution*

Dilute an aliquot portion of the extract obtained by Method 9.1, 9.2 or 9.3 with water and/or hydrochloric acid (4.1) or (4.2) so as to obtain, in the final solution for measurement, a concentration of the element to be determined that is appropriate to the calibration range used (7.2) and a hydrochloric acid concentration of at least 0,5 mol/l and not more than 2,5 mol/l. This operation may require one or more successive dilutions.

Take an aliquot portion of the final solution obtained by dilution of the extract, let (a) be its volume in ml, and pour into a 100 ml volumetric flask. When determining the cobalt, iron, manganese or zinc content, add 10 ml of the lanthanum salt solution (4.3). Make up to volume with the 0,5 mol/l hydrochloric acid solution (4.2) and mix thoroughly. This is the final solution for measurement. Let D be the dilution factor.

7. **Procedure**

7.1. *Preparation of a blank solution*

Prepare a blank solution by repeating the whole procedure from the extraction stage, omitting only the test sample of fertiliser.

7.2. *Preparation of calibration solutions*

From the working calibration solution prepared using the Method given for each individual micro-nutrient, prepare in 100 ml volumetric flasks a series of at least five calibration solutions of increasing concentration within the optimum measuring range of the spectrometer. If necessary, adjust the concentration of hydrochloric acid to bring it as close as possible to that of the diluted test solution (6.2). For determining cobalt, iron, manganese or zinc, add 10 ml of the same lanthanum salt solution (4.3) as used in 6.2. Make up to volume with the 0,5 mol/l hydrochloric acid solution (4.2) and mix thoroughly.

7.3. *Determination*

Prepare the spectrometer (5) for the determination and adjust to the wavelength given in the Method for the individual micro-nutrient concerned.

Spray three times in succession the calibration solutions (7.2), the test solution (6.2) and the blank solution (7.1), noting each result and flushing the instrument with distilled water between individual sprayings.

Construct the calibration curve by plotting the average spectrometer reading for each calibration solution (7.2) along the ordinate and the corresponding concentration of the element, expressed in $\mu\text{g/ml}$, along the abscissa.

From this curve, determine the concentrations of the relevant micro-nutrient in the test solution x_s (6.2) and in the blank solution x_b (7.1), expressing these concentrations in $\mu\text{g per ml}$.

8. Expression of results

The percentage of micro-nutrient (E) in the fertiliser is equal to:

$$E (\%) = [(x_s - x_b) \times V \times D] / (M \times 10^4)$$

If Method 9.3 has been used:

$$E (\%) = [(x_s - x_b) \times V \times 2D] / (M \times 10^4)$$

Where

E is the amount of the micro-nutrient determined, expressed as a percentage of the fertiliser;

x_s is the concentration of the test solution (6.2), in $\mu\text{g/ml}$;

x_b is the concentration of the blank solution (7.1), in $\mu\text{g/ml}$;

V is the volume of the extract obtained by Method 9.1 or 9.2, in ml;

D is the factor corresponding to the dilution carried out in 6.2;

M is the mass of the test sample taken in accordance with Method 9.1 or 9.2, in grams.

Calculation of dilution factor D:

If (a1), (a2), (a3),..., (ai) and (a) are the aliquot portions and (v1), (v2), (v3),..., (vi) and (100) are the volumes in ml corresponding to their respective dilutions, the dilution factor D will be equal to:

$$D = (v1/a1) \times (v2/a2) \times (v3/a3) \times \dots \times (vi/ai) \times (100/a)$$

Method 9.5

Determination of boron in fertiliser extracts by means of spectrometry with azomethine-H

1. Scope

This Method describes a procedure for determining boron in fertiliser extracts.

2. Field of application

This procedure is applicable to analysing samples of fertilisers extracted by Methods 9.1 and 9.2 for which a declaration of total and/or water-soluble boron is required by Annex 1 to this Regulation.

3. Principle

In an azomethine-H solution, borate ions form a yellow complex the concentration of which is determined by molecular absorption spectrometry at 410 nm. Interfering ions are masked with EDTA.

4. Reagents

4.1. EDTA buffer solution

Place in a 500 ml volumetric flask containing 300 ml of water:

— 75 g of ammonium acetate ($\text{NH}_4\text{OOCCH}_3$);

— 10 g of disodium salt of ethylene diamine tetraacetic acid (Na_2EDTA);

— 40 ml of acetic acid (CH_3COOH , $d_{20} = 1,05 \text{ g/ml}$).

Make up to volume with water and mix thoroughly. The pH of the solution, checked by means of a glass electrode, must be $4,8 \pm 0,1$.

- 4.2. *Azomethine-H solution*
Place in a 200 ml volumetric flask
- 10 ml of the buffer solution (4.1);
 - 400 mg of azomethine-H ($C_{17}H_{12}NNaO_8S_2$);
 - 2 g of absorbic acid ($C_6H_8O_6$);
 - Make up to volume and mix thoroughly. Do not prepare large quantities of this reagent as it is stable for only a few days.
- 4.3. *Boron calibration solutions*
- 4.3.1. *Boron stock solution (100 µg/ml)*
Dissolve 0,5719 g of boric acid (H_2BO_3) in water in a 1 000 ml volumetric flask. Make up to volume with water and mix thoroughly. Transfer to a plastic bottle for storage in a refrigerator.
- 4.3.2. *Boron working solution (10 µg/ml)*
Place 50 ml of stock solution (4.3.1) in a 500 ml volumetric flask. Make up to volume with water and mix thoroughly.
5. **Apparatus**
Spectrometer fitted for molecular absorption with cells having a 10 mm optical path and set to a wavelength of 410 nm.
6. **Preparation of the solution to be analysed**
- 6.1. *Preparation of the boron solution*
See Methods 9.1 and/or 9.2 and, if appropriate, 9.3.
- 6.2. *Preparation of the test solution*
Dilute an aliquot portion of extract (6.1) to obtain a boron concentration as specified in 7.2. Two successive dilutions may be necessary. Let D be the dilution factor.
- 6.3. *Preparation of the correction solution*
If the test solution (6.2) is coloured, prepare a corresponding correction solution by placing in a plastic flask 5 ml of test solution (6.2), 5 ml of EDTA buffer solution (4.1) and 5 ml of water and mix thoroughly.
7. **Procedure**
- 7.1. *Preparation of the blank solution*
Prepare a blank solution by repeating the whole procedure from the extraction stage, omitting only the test sample of fertiliser.
- 7.2. *Preparation of the calibration solutions*
Transfer 0, 5, 10, 15, 20 and 25 ml of the working calibration solution (4.3.3) to a series of 100 ml volumetric flasks. Make up to 100 ml with water and mix thoroughly. These solutions contain between 0 and 2,5 µg/ml of boron.
- 7.3. *Colour development*
Transfer 5 ml of the calibration solutions (7.2), test solutions (6.2) and blank (7.1) to a series of plastic flasks. Add 5 ml of the EDTA buffer solution (4.1). Add 5 ml of the azomethine-H solution (4.2).

Mix thoroughly and allow the colour to develop in the dark for $2\frac{1}{2}$ to three hours.
- 7.4. *Determination*
Measure the absorbance of the solutions obtained at 7.3 and if appropriate the correction solution (6.3) against water at a wavelength of 410 nm. Rinse the cells with water before each new reading.

8. Expression of results

Plot a calibration curve of the concentration of the calibration solutions (7.2) along the abscissa and the absorbance given by the spectrometer (7.4) along the ordinate.

Read off the calibration curve the concentration of boron in the blank (7.1), the concentration of boron in the test solution (6.2) and, if the test solution is coloured, the corrected concentration of the test solution. To calculate the latter, subtract the absorbance of the correction solution (6.3) from the absorbance of the test solution (6.2) and determine the corrected concentration of the test solution. Note the concentration of the test solution (6.2), with or without correction, $X(x_s)$ and of the blank (x_b).

The percentage of boron in the fertiliser is given by:

$$B \% = [(x_s - x_b) \times V \times D] / (M \times 10^4)$$

If Method 9.3 is used:

$$B \% = [(x_s - x_b) \times V \times 2D] / (M \times 10^4)$$

where

B is the quantity of boron expressed as a percentage of the fertiliser;

x_s is the concentration ($\mu\text{g/ml}$) in the test solution (6.2), with or without correction;

x_b is the concentration ($\mu\text{g/ml}$) in the blank (7.1);

V is the volume in ml of extract obtained in accordance with Method 9.1 or 9.2;

D is the factor corresponding to the dilution carried out in 6.2;

M is the mass in grams of the test sample taken in accordance with Method 9.1 or 9.2.

Calculation of the dilution factor D: if (a1) and (a2) are successive aliquot portions and (v1) and (v2) are the volumes corresponding to their respective dilutions, the dilution factor D is given by:

$$D = (v1/a1) \times (v2/a2)$$

Method 9.6

Determination of cobalt in fertiliser extracts by atomic absorption spectrometry

1. Scope

This Method describes a procedure for determining cobalt in fertiliser extracts.

2. Field of application

This Procedure is applicable to analysing samples of fertilisers extracted by Methods 9.1 and 9.2 for which a declaration of total and/or water-soluble cobalt is required by Annex I E of this Regulation.

3. Principle

After suitable treatment and dilution of the extracts, the cobalt content is determined by atomic absorption spectrometry.

4. Reagents

4.1. Hydrochloric acid solution, about 6 mol/l

See Method 9.4 (4.1).

4.2. Hydrochloric acid solution, about 0,5 mol/l

See Method 9.4 (4.2).

4.3. *Lanthanum salt solutions (10 g of La per litre)*

See Method 9.4 (4.3).

4.4. *Cobalt calibration solutions*4.4.1. *Cobalt stock solution (1 000 µg/ml)*

In a 250 ml beaker, weigh to the nearest 0,1 mg, 1 g of cobalt, add 25 ml of 6 mol/l hydrochloric acid (4.1) and heat on a hotplate until the cobalt is completely dissolved. When cool, transfer quantitatively to a 1 000 ml volumetric flask. Make up to volume with water and mix thoroughly.

4.4.2. *Cobalt working solution (100 µg/ml)*

Place 10 ml of the stock solution (4.4.1) in a 100 ml volumetric flask. Make up to volume with 0,5 mol/l hydrochloric acid solution (4.2) and mix thoroughly.

5. **Apparatus**

Atomic absorption spectrometer: see Method 9.4 (5). The instrument must be equipped with a source of rays characteristic of cobalt (240,7 nm). The spectrometer must allow background correction to be made.

6. **Preparation of the solution to be analysed**6.1. *Cobalt extract solution*

See Methods 9.1 and/or 9.2 and, if appropriate, 9.3.

6.2. *Preparation of the test solution*

See Method 9.4 (6.2). The test solution must contain 10 % (v/v) of a lanthanum salt solution (4.3).

7. **Procedure**7.1. *Preparation of blank solution*

See Method 9.4 (7.1). The blank must contain 10 % (v/v) of the lanthanum salt solution used in 6.2.

7.2. *Preparation of calibration solutions*

See Method 9.4 (7.2).

For an optimum determination range of 0 to 5 µg/ml of cobalt, place 0, 0,5, 1, 2, 3, 4 and 5 ml respectively of working solution (4.4.2) in a series of 100 ml volumetric flasks. If necessary adjust the hydrochloric acid concentration as closely as possible to that of the test solution. Add to each flask 10 ml of the lanthanum salt solution used in 6.2. Make up to 100 ml with 0,5 mol/l hydrochloric acid solution (4.2) and mix thoroughly. These solutions contain 0, 0,5, 1, 2, 3, 4 and 5 µg/ml respectively of cobalt.

7.3. *Determination*

See Method 9.4 (7.3). Prepare the spectrometer (5) for measurement at a wavelength of 240,7 nm.

8. **Expression of results**

See Method 9.4 (8).

The percentage of cobalt in the fertiliser is given by:

$$\text{Co \%} = [(x_s - x_b) \times V \times D] / (M \times 10^4)$$

If Method 9.3 is used:

$$\text{Co \%} = [(x_s - x_b) \times V \times 2D] / (M \times 10^4)$$

where

Co is the quantity of cobalt expressed as a percentage of the fertiliser;

x_s is the concentration in µg/ml of the test solution (6.2);

x_b is the concentration in µg/ml of the blank solution (7.1);

V is the volume in ml of extract obtained in accordance with Method 9.1 or 9.2;

D is the factor corresponding to the dilution carried out in 6.2;

M is the mass in grams of the test sample taken in accordance with Method 9.1 or 9.2.

Calculation of the dilution factor D: if (a1), (a2), (a3),..., (ai) and (a) are aliquot portions and (v1), (v2), (v3),..., (vi) and (100) are the volumes in ml corresponding to their respective dilutions, the dilution factor D is given by:

$$D = (v1/a1) \times (v2/a2) \times (v3/a3) \times \dots \times (vi/ai) \times (100/a)$$

Method 9.7

Determination of copper in fertiliser extracts by atomic absorption spectrometry

1. Scope

This Method describes a procedure for determining copper in fertiliser extracts.

2. Field of application

This procedure is applicable to analysing samples of fertilisers extracted by Methods 9.1 and 9.2 for which a declaration of total and/or water-soluble copper is required by Annex I E to this Regulation.

3. Principle

After suitable treatment and dilution of the extracts, the copper content is determined by atomic absorption spectrometry.

4. Reagents

4.1. Hydrochloric acid solution, about 6 mol/l

See Method 9.4 (4.1).

4.2. Hydrochloric acid solution, about 0,5 mol/l

See Method 9.4 (4.2).

4.3. Hydrogen peroxide solution (30 % H₂O₂, d₂₀ = 1,11 g/ml), free from micro-nutrients

4.4. Copper calibration solutions

4.4.1. Copper stock solution (1 000 µg/ml)

In a 250 ml beaker, weigh to the nearest 0,1 mg, 1 g of copper, add 25 ml of 6 mol/l hydrochloric acid (4.1), add 5 ml hydrogen peroxide solution (4.3) and heat on a hotplate until the copper is completely dissolved. Transfer quantitatively to a 1 000 ml volumetric flask. Make up to volume with water and mix thoroughly.

4.4.2. Copper working solution (100 µg/ml)

Place 20 ml of the stock solution (4.4.1) in a 200 ml volumetric flask. Make up to volume with 0,5 mol/l hydrochloric acid solution (4.2) and mix thoroughly.

5. Apparatus

Spectrometer equipped for atomic absorption: see Method 9.4 (5). The instrument must be fitted with a source of rays characteristics of copper (324,8 nm).

6. Preparation of the solution to be analysed

6.1. Copper extract solution

See Methods 9.1 and/or 9.2 and, if appropriate, 9.3.

6.2. *Preparation of the test solution*

See Method 9.4 (6.2).

7. **Procedure**7.1. *Preparation of blank solution*

See Method 9.4 (7.1).

7.2. *Preparation of calibration solutions*

See Method 9.4 (7.2).

For an optimum determination range of 0 to 5 µg/ml of copper, place 0, 0,5, 1, 2, 3, 4 and 5 ml respectively of working solution (4.4.2) in a series of 100 ml volumetric flasks. If necessary adjust the hydrochloric acid concentration as closely as possible to that of the test solution (6.2). Make up to 100 ml with 0,5 mol/l hydrochloric acid solution (4.2) and mix thoroughly. These solutions contain 0, 0,5, 1, 2, 3, 4 and 5 µg/ml respectively of copper.

7.3. *Determination*

See Method 9.4 (7.3). Prepare the spectrometer (5) for measurement at a wavelength of 324,8 nm.

8. **Expression of results**

See Method 9.4 (8).

The percentage of copper in the fertiliser is given by:

$$\text{Cu \%} = [(x_s - x_b) \times V \times D] / (M \times 10^4)$$

If Method 9.3 is used:

$$\text{Cu \%} = [(x_s - x_b) \times V \times 2D] / (M \times 10^4)$$

where

Cu is the quantity of copper expressed as a percentage of the fertiliser;

x_s is the concentration in µg/ml of the test solution (6.2);

x_b is the concentration in µg/ml of the blank solution (7.1);

V is the volume in ml of extract obtained in accordance with Method 9.1 or 9.2;

D is the factor corresponding to the dilution carried out in 6.2;

M is the mass in grams of the test sample taken in accordance with Method 9.1 or 9.2.

Calculation of the dilution factor D: if (a1), (a2), (a3),..., (ai) and (a) are aliquot portions and (v1), (v2), (v3),..., (vi) and (100) are the volumes in ml corresponding to their respective dilutions, the dilution factor D is given by:

$$D = (v1/a1) \times (v2/a2) \times (v3/a3) \times \dots \times (vi/ai) \times (100/a)$$

Method 9.8

Determination of iron in fertiliser extracts by atomic absorption spectrometry1. **Scope**

This Method describes a procedure for determining iron in fertiliser extracts.

2. **Field of application**

This procedure is applicable to analysing samples of fertilisers extracted by Methods 9.1 and 9.2 for which a declaration of total and/or water-soluble iron is required by Annex 1E of this Regulation.

3. Principle

After suitable treatment and dilution of the extracts, the iron content is determined by atomic absorption spectrometry.

4. Reagents

4.1. Hydrochloric acid solution, about 6 mol/l

See Method 9.4 (4.1).

4.2. Hydrochloric acid solution, about 0,5 mol/l

See Method 9.4 (4.2).

4.3. Hydrogen peroxide solution (30 % H₂O₂, d₂₀ = 1,11 g/ml), free from micro-nutrients

4.4. Lanthanum salt solutions (10 g of La per litre)

See Method 9.4 (4.3).

4.5. Iron calibration solutions

4.5.1. Iron stock solution (1 000 µg/ml)

In a 500 ml beaker, weigh to the nearest 0,1 mg, 1 g of iron wire, add 200 ml of 6 mol/l hydrochloric acid (4.1) and 15 ml of hydrogen peroxide solution (4.3). Heat on a hotplate until the iron is completely dissolved. When cool, transfer quantitatively to a 1 000 ml volumetric flask. Make up to volume with water and mix thoroughly.

4.5.2. Iron working solution (100 µg/ml)

Place 20 ml of the stock solution (4.5.1) in a 200 ml volumetric flask. Make up to volume with 0,5 mol/l hydrochloric acid solution (4.2) and mix thoroughly.

5. Apparatus

Atomic absorption spectrometer: see Method 9.4 (5). The instrument must be fitted with a source of rays characteristic of iron (248,3 nm).

6. Preparation of the solution to be analysed

6.1. Iron extract solution

See Methods 9.1 and/or 9.2 and, if appropriate, 9.3.

6.2. Preparation of the test solution

See Method 9.4 (6.2). The test solution must contain 10 % (v/v) of a lanthanum salt solution.

7. Procedure

7.1. Preparation of blank solution

See Method 9.4 (7.1). The test solution must contain 10 % (v/v) of the lanthanum salt solution used in 6.2.

7.2. Preparation of calibration solutions

See Method 9.4 (7.2).

For an optimum determination range of 0 to 10 µg/ml of iron, place 0, 2, 4, 6, 8 and 10 ml respectively of working solution (4.5.2) in a series of 100 ml volumetric flasks. If necessary adjust the hydrochloric acid concentration as closely as possible to that of the test solution. Add 10 ml of the lanthanum salt solution used in 6.2. Make up to volume with 0,5 mol/l hydrochloric acid solution (4.2) and mix thoroughly. These solutions contain 0, 2, 4, 6, 8 and 10 µg/ml respectively of iron.

7.3. Determination

See Method 9.4 (7.3). Prepare the spectrometer (5) for measurement at a wavelength of 248,3 nm.

8. Expression of results

See Method 9.4 (8).

The percentage of iron in the fertiliser is given by:

$$\text{Fe \%} = [(x_s - x_b) \times V \times D] / (M \times 10^4)$$

If Method 9.3 is used:

$$\text{Fe \%} = [(x_s - x_b) \times V \times 2D] / (M \times 10^4)$$

where

Fe is the quantity of iron expressed as a percentage of the fertiliser;

x_s is the concentration in $\mu\text{g/ml}$ of the test solution (6.2);

x_b is the concentration in $\mu\text{g/ml}$ of the blank solution (7.1);

V is the volume in ml of extract obtained in accordance with Method 9.1 or 9.2;

D is the factor corresponding to the dilution carried out in 6.2;

M is the mass in grams of the test sample taken in accordance with Method 9.1 or 9.2.

Calculation of the dilution factor D: if (a1), (a2), (a3),..., (ai) and (a) are aliquot portions and (v1), (v2), (v3),..., (vi) and (100) are the volumes in ml corresponding to their respective dilutions, the dilution factor D is given by:

$$D = (v1/a1) \times (v2/a2) \times (v3/a3) \times \dots \times (vi/ai) \times (100/a)$$

Method 9.9

Determination of manganese in fertiliser extracts by atomic absorption spectrometry

1. Scope

This Method describes a procedure for determining manganese in fertiliser extracts.

2. Field of application

This procedure is applicable to analysing samples of fertilisers extracted by Methods 9.1 and 9.2 for which a declaration of total and/or water-soluble manganese is required by Annex I E of this Regulation.

3. Principle

After suitable treatment and dilution of the extracts, the manganese level is determined by atomic absorption spectrometry.

4. Reagents

4.1. Hydrochloric acid solution, about 6 mol/l

See Method 9.4 (4.1).

4.2. Hydrochloric acid solution, about 0,5 mol/l

See Method 9.4 (4.2).

4.3. Lanthanum salt solutions (10 g of La per litre)

See Method 9.4 (4.3).

4.4. *Manganese calibration solutions*

4.4.1. Manganese stock solution (1 000 µg/ml)

In a 250 ml beaker, weigh to the nearest 0,1 mg, 1 g of manganese, add 25 ml of 6 mol/l hydrochloric acid (4.1). Heat on a hotplate until the manganese is completely dissolved. When cool, transfer quantitatively to a 1 000 ml volumetric flask. Make up to volume with water and mix thoroughly.

4.4.2. Manganese working solution (100 µg/ml)

Dilute 20 ml of the stock solution (4.4.1) in the 0,5 mol/l hydrochloric acid solution (4.2) in a 200 ml volumetric flask. Make up to volume with 0,5 mol/l hydrochloric acid solution (4.2) and mix thoroughly.

5. **Apparatus**

Atomic absorption spectrometer: see Method 9.4 (5). The instrument must be fitted with a source of lines characteristic of manganese (279,6 nm).

6. **Preparation of the solution to be analysed**

6.1. *Manganese extract solution*

See Methods 9.1 and/or 9.2 and, if appropriate, 9.3.

6.2. *Preparation of the test solution*

See Method 9.4 (6.2). The test solution must contain 10 % by volume of lanthanum salt solution (4.3).

7. **Procedure**

7.1. *Preparation of blank solution*

See Method 9.4 (7.1). The test solution must contain 10 % by volume of the lanthanum salt solution used in 6.2.

7.2. *Preparation of calibration solutions*

See Method 9.4 (7.2).

For an optimum determination range of 0 to 5 µg/ml of manganese, place 0, 0,5, 1, 2, 3, 4 and 5 ml respectively of working solution (4.4.2) in a series of 100 ml volumetric flasks. Where necessary adjust the hydrochloric acid concentration to bring it as close as possible to that of the test solution. To each flask, add 10 ml of the lanthanum salt solution used in 6.2. Make up to 100 ml with 0,5 mol/l hydrochloric acid solution (4.2) and mix thoroughly. These solutions contain 0, 0,5, 1, 2, 3, 4 and 5 µg/ml respectively of manganese.

7.3. *Determination*

See Method 9.4 (7.3). Prepare the spectrometer (5) for measurement at a wavelength of 279,6 nm.

8. **Expression of results**

See Method 9.4 (8).

The percentage of manganese in the fertiliser is as follows:

$$\text{Mn \%} = [(x_s - x_b) \times V \times D] / (M \times 10^4)$$

If Method 9.3 is used:

$$\text{Mn \%} = [(x_s - x_b) \times V \times 2D] / (M \times 10^4)$$

where

Mn is the quantity of manganese expressed as a percentage of the fertiliser;

x_s is the concentration in µg/ml of the test solution (6.2);

x_b is the concentration in µg/ml of the blank solution (7.1);

V is the volume in ml of extract obtained in accordance with Method 9.1 or 9.2;

D is the factor corresponding to the dilution carried out in 6.2;

M is the mass in grams of the test sample taken in accordance with Method 9.1 or 9.2.

Calculation of the dilution factor D: if (a1), (a2), (a3),..., (ai) and (a) are aliquot portions and (v1), (v2), (v3),..., (vi) and (100) are the volumes in ml corresponding to their respective dilutions, the dilution factor D will be equal to:

$$D = (v1/a1) \times (v2/a2) \times (v3/a3) \times \dots \times (vi/ai) \times (100/a)$$

Method 9.10

Determination of molybdenum in fertiliser extracts by spectrometry of a complex with ammonium thiocyanate

1. Scope

This Method describes a procedure for determining molybdenum in fertiliser extracts.

2. Field of application

This procedure is applicable to analysing samples of fertilisers extracted by Methods 9.1 and 9.2 for which a declaration of total and/or water-soluble molybdenum is required by Annex I E to this Regulation.

3. Principle

Molybdenum (V) forms a complex $[\text{MoO}(\text{SCN})_5]$ —in an acid medium with SCN^- ions.

The complex is extracted with n-butyl acetate. Interfering ions such as those of iron remain in the aqueous phase. The yellow-orange colour is determined by molecular absorption spectrometry at 470 nm.

4. Reagents

4.1. Dilute hydrochloric acid solution (HCl), about 6 mol/l

See Method 9.4 (4.1).

4.2. Copper solution (70 mg/l) in 1,5 mol/l hydrochloric acid

Dissolve 275 mg of copper sulphate ($\text{CuSO}_4 \cdot 5\text{H}_2\text{O}$) weighed to within 0,1 mg in 250 ml of the 6 mol/l hydrochloric acid solution (4.1) in a 1 000 ml volumetric flask. Make up to volume with water and mix thoroughly.

4.3. Ascorbic acid solution (50 g/l)

Dissolve 50 g of ascorbic acid ($\text{C}_6\text{H}_8\text{O}_6$) in water in a 1 000 ml volumetric flask. Make up to volume with water, mix thoroughly and keep in a refrigerator.

4.4. n-butyl acetate

4.5. Ammonium thiocyanate solution, 0,2 mol/l

Dissolve 15,224 g of NH_4SCN in water in a 1 000 ml volumetric flask. Make up to volume with water; mix thoroughly and store in a dark-coloured bottle.

4.6. Stannous chloride solution (50 g/l) in 2 mol/l hydrochloric acid

This solution must be perfectly clear and prepared immediately before use. Very pure stannous chloride must be used otherwise the solution will not be clear.

To prepare 100 ml of solution, dissolve 5 g of ($\text{SnCl}_2 \cdot 2\text{H}_2\text{O}$) in 35 ml of 6 mol/l HCl solution (4.1). Add 10 ml of the copper solution (4.2). Make up to volume with water and mix thoroughly.

4.7. Molybdenum calibration solutions

4.7.1. Molybdenum stock solution (500 µg/ml)

Dissolve 0,920 g of ammonium molybdate $[(\text{NH}_4)_6\text{Mo}_7\text{O}_{24} \cdot 4\text{H}_2\text{O}]$ weighed to within 0,1 mg in the 6 mol/l hydrochloric acid (4.1) in a 1 000 ml volumetric flask. Make up to volume with that solution and mix thoroughly.

- 4.7.2. Molybdenum intermediate solution (25 µg/ml)
Place 25 ml of the stock solution (4.7.1) in a 500 ml volumetric flask. Make up to volume with 6 mol/l hydrochloric acid (4.1) and mix thoroughly.
- 4.7.3. Molybdenum working solution (2,5 µg/ml)
Place 10 ml of the intermediate solution (4.7.2) in a 100 ml volumetric flask. Make up to volume with 6 mol/l hydrochloric acid (4.1) and mix thoroughly.
5. **Apparatus**
- 5.1. Spectrometer fitted for molecular absorption with cuvettes having a 20 mm optical path and set to a wavelength of 470 nm
- 5.2. 200 or 250 ml separating funnels
6. **Preparation of the solution to be analysed**
- 6.1. *Molybdenum extract solution*
See Methods 9.1 and/or 9.2 and, if appropriate, 9.3.
- 6.2. *Preparation of the test solution*
Dilute an aliquot portion of the extract (6.1) with 6 mol/l hydrochloric acid solution (4.1) so as to obtain an appropriate molybdenum concentration. Let D be the dilution factor.

Take an aliquot portion (a) from the extract solution containing 1 to 12 µg molybdenum and place it in the separating funnel (5.2). Make up to 50 ml with the 6 mol/l hydrochloric acid solution (4.1).
7. **Procedure**
- 7.1. *Preparation of the blank solution*
Prepare a blank solution by repeating the whole procedure from the extraction stage, omitting only the test sample of fertiliser.
- 7.2. *Preparation of the series of calibration solutions*
Prepare a series of at least six calibration solutions of increasing concentration corresponding to the optimum response range of the spectrometer.

For the interval 0-12,5 µg molybdenum, place 0, 1, 2, 3, 4 and 5 ml respectively of working solution (4.7.3) in the separating funnels (5.2). Make up to 50 ml with 6 mol/l hydrochloric acid (4.1). The funnels contain respectively 0, 2,5, 5, 7,5, 10 and 12,5 µg molybdenum.
- 7.3. *Development and separation of the complex*
To each separating funnel (6.2, 7.1 and 7.2), add in the following order:
- 10 ml of the copper solution (4.2)
 - 20 ml of the ascorbic acid solution (4.3);
- mix thoroughly and wait for two or three minutes. Then add:
- 10 ml of n-butyl acetate (4.4), using a precision pipette
 - 20 ml of the thiocyanate solution (4.5).
- Shake for one minute to extract the complex in the organic phase; allow to precipitate; after the separation of the two phases, draw off the entire aqueous phase and discard it; then wash the organic phase with:
- 10 ml of the stannous chloride solution (4.6).
- Shake for one minute. Allow to precipitate and draw off the entire aqueous phase. Collect the organic phase in a test tube; this will make it possible to collect the drops of water in suspension.

7.4. *Determination*

Measure the absorbencies of the solutions obtained at 7.3 at a wavelength of 470 nm using the 0 µg/ml molybdenum calibration solution (7.2) as a reference.

8. **Expression of results**

Construct the calibration curve by plotting the corresponding masses of molybdenum in the calibration solutions (7.2) expressed in µg along the abscissa and the corresponding values of the absorbencies (7.4) given by the spectrometer reading along the ordinate.

From this curve determine the mass of molybdenum in the test solution (6.2) and the blank solution (7.1). These masses are designated (x_s) and (x_b) respectively.

The percentage of molybdenum in the fertiliser is:

$$\text{Mo \%} = [(x_s - x_b) \times V/a \times D]/(M \times 10^4)$$

If Method 9.3 is used:

$$\text{Mo \%} = [(x_s - x_b) \times V/a \times 2D]/(M \times 10^4)$$

where

Mo is the quantity of molybdenum expressed as a percentage of the fertiliser;

a is the volume in ml of the aliquot taken from the last dilute solution (6.2);

x_s is the Mo mass in µg in the test solution (6.2);

x_b is the Mo mass in µg in the blank solution (7.1) the volume of which corresponds to the volume (a) of the aliquot of the test solution (6.2);

V is the volume in ml of extract solution obtained in accordance with Method 9.1 or 9.2;

D is the factor corresponding to the dilution performed in 6.2;

M is the mass in grams of the test sample taken in accordance with Method 9.1 or 9.2.

Calculation of the dilution factor D: where (a1), (a2) are successive aliquot portions and (v1), (v2) are the volumes corresponding to their respective dilutions, the dilution factor D will be:

$$D = (v1/a1) \times (v2/a2)$$

Method 9.11

Determination of zinc in fertiliser extracts by atomic absorption spectrometry1. **Scope**

This Method describes a procedure for determining zinc in fertiliser extracts.

2. **Field of application**

This procedure is applicable to analysing samples of fertilisers extracted by Methods 9.1 and 9.2 for which a declaration of total and/or water-soluble zinc is required by Annex I E to this Regulation.

3. **Principle**

After suitable treatment and dilution of the extracts, the zinc level is determined by atomic absorption spectrometry.

4. **Reagents**4.1. *Hydrochloric acid solution, about 6 mol/l*

See Method 9.4 (4.1).

4.2. *Hydrochloric acid solution, about 0,5 mol/l*

See Method 9.4 (4.2).

4.3. *Lanthanum salt solutions (10 g of La per litre)*

See Method 9.4 (4.3).

4.4. *Zinc calibration solutions*4.4.1. *Zinc stock solution (1 000 µg/ml)*

In a 1 000 ml volumetric flask, dissolve 1 g of zinc powder or flakes weighed to within 0,1 mg in 25 ml of 6 mol/l hydrochloric acid (4.1). When completely dissolved, make up to volume with water and mix thoroughly.

4.4.2. *Zinc working solution (100 µg/ml)*

In a 200 ml volumetric flask, dilute 20 ml of the stock solution (4.4.1) in 0,5 mol/l hydrochloric acid solution (4.2). Make up to volume with the 0,5 mol/l hydrochloric acid solution (4.2) and mix thoroughly.

5. **Apparatus**

Atomic absorption spectrometer: see Method 9.4 (5). The instrument must be fitted with a source of lines characteristic of zinc (213,8 nm), the spectrometer must allow background correction to be made.

6. **Preparation of the solution to be analysed**6.1. *Zinc extract solution*

See Methods 9.1 and/or 9.2 and, if appropriate, 9.3.

6.2. *Preparation of the test solution*

See Method 9.4 (6.2). The test solution must contain 10 % by volume of lanthanum salt solution (4.3).

7. **Procedure**7.1. *Preparation of blank solution*

See Method 9.4 (7.1). The test solution must contain 10 % by volume of the lanthanum salt solution used in 6.2.

7.2. *Preparation of calibration solutions*

See Method 9.4 (7.2).

For an optimum interval of 0 to 5 µg/ml of zinc, place 0, 0,5, 1, 2, 3, 4 and 5 ml respectively of working solution (4.4.2) in a series of 100 ml volumetric flasks. Where necessary adjust the hydrochloric acid concentration to bring it as close as possible to that of the test solution. To each flask, add 10 ml of the lanthanum salt solution used in 6.2. Make up to 100 ml with 0,5 mol/l hydrochloric acid solution (4.2) and mix thoroughly. These solutions contain 0, 0,5, 1, 2, 3, 4 and 5 µg/ml respectively of zinc.

7.3. *Determination*

See Method 9.4 (7.3). Prepare the spectrometer (5) for measurement at a wavelength of 213,8 nm.

8. **Expression of results**

See Method 9.4 (8).

The percentage of zinc in the fertiliser is as follows:

$$\text{Zn \%} = [(x_s - x_b) \times V \times D]/(M \times 10^4)$$

If Method 9.3 is used:

$$\text{Zn \%} = [(x_s - x_b) \times V \times 2D]/(M \times 10^4)$$

where

Zn is the quantity of zinc expressed as a percentage of the fertiliser;

x_s is the concentration in $\mu\text{g/ml}$ of the test solution (6.2);

x_b is the concentration in $\mu\text{g/ml}$ of the blank solution (7.1);

V is the volume in ml of extract obtained in accordance with Method 9.1 or 9.2;

D is the factor corresponding to the dilution carried out in 6.2;

M is the mass in grams of the test sample taken in accordance with Method 9.1 or 9.2.

Calculation of the dilution factor D: if (a1), (a2), (a3),..., (ai) and (a) are aliquot portions and (v1), (v2), (v3),..., (vi) and (100) are the volumes in ml corresponding to their respective dilutions, the dilution factor D will be equal to:

$$D = (v1/a1) \times (v2/a2) \times (v3/a3) \times \dots \times (vi/ai) \times (100/a)$$

Methods 10

Micro-nutrients at a concentration greater than 10 %

Method 10.1

Extraction of total micro-nutrients

1. Scope

This Method defines the procedure for extracting the following micro-nutrients: total boron, total cobalt, total copper, total iron, total manganese, total molybdenum and total zinc. The aim is to carry out the minimum number of extractions, making use wherever possible of the same extract to determine the total level of each of the micro-nutrients listed above.

2. Field of application

This procedure concerns Community fertilisers covered by Annex I E to this Regulation containing one or more of the following micro-nutrients: boron, cobalt, copper, iron, manganese, molybdenum and zinc. It is applicable to each micro-nutrient the declared content of which is more than 10 %.

3. Principle

Dissolution in boiling dilute hydrochloric acid.

Note

The extraction is empirical and may not be quantitative depending on the product or the other constituents of the fertiliser. In particular, in the case of certain manganese oxides, the quantity extracted may be substantially smaller than the total quantity of manganese which the product contains. It is the responsibility of the fertiliser manufacturers to ensure that the declared content actually corresponds to the quantity extracted under the conditions pertaining to the method.

4. Reagents

4.1. Dilute hydrochloric acid (HCl) solution, about 6 mol/l

Mix 1 volume of hydrochloric acid ($d_{20} = 1,18 \text{ g/ml}$) with 1 volume of water.

4.2. Concentrated ammonia solution (NH_4OH , $d_{20} = 0,9 \text{ g/ml}$)

5. Apparatus

5.1. Electric hotplate with variable temperature control

5.2. pH meter

Note

Where the boron content of an extract is to be determined, do not use borosilicate glassware. As the Method involves boiling, teflon or silica is preferable. Rinse the glassware thoroughly if it has been washed in detergents containing borates.

6. **Preparation of the sample**

See Method 1.

7. **Procedure**7.1. *Test sample*

Take a quantity of fertiliser weighing 1 or 2 g depending on the declared content of element in the product. The following table shall be used to obtain a final solution which, after appropriate dilution, will be within the measuring range for each method. Samples should be weighed to within 1 mg.

Declared content of micro-nutrient in the fertiliser (%)	> 10 < 25	≥ 25
Mass of test sample (g)	2	1
Mass of element in the sample (mg)	> 200 < 500	≥ 250
Volume of extract V (ml)	500	500
Concentration of element in extract (mg/l)	> 400 < 1 000	≥ 500

Place the sample in a 250 ml beaker.

7.2. *Preparation of the solution*

If necessary moisten the sample with a little water, add 10 ml of dilute hydrochloric acid (4.1) per gram of fertiliser carefully, in small amounts, then add about 50 ml of water. Cover the beaker with a watch glass and mix. Bring to the boil on the hotplate and boil for 30 minutes. Allow to cool, stirring occasionally. Transfer quantitatively to a 500 ml volumetric flask. Make up to volume with water and mix thoroughly. Filter through a dry filter into a dry container. Discard the first portion. The extract must be perfectly clear.

It is recommended that the determination be carried out without delay on aliquot portions of the clear filtrate, if not the containers should be stoppered.

Note

Extracts in which the boron content has to be determined: Adjust the pH to between 4 and 6 with concentrated ammonia (4.2).

8. **Determination**

The determination of each micro-nutrient is to be carried out on the aliquot portions indicated in the Method for each individual micro-nutrient.

Methods 10.5, 10.6, 10.7, 10.9 and 10.10 cannot be used to determine elements present in a chelated or complexed form. In such cases Method 10.3 must be used prior to the determination.

In the case of determination by AAS (Methods 10.8 and 10.11) such treatment may not be necessary.

Method 10.2

Extraction of water-soluble micro-nutrients1. **Scope**

This Method defines the procedure for extracting water-soluble forms of the following micro-nutrients: boron, cobalt, copper, iron, manganese, molybdenum and zinc. The aim is to carry out the minimum number of extractions, making use wherever possible of the same extract to determine the level of each of the micro-nutrients listed above.

2. **Field of application**

This Procedure concerns Community fertilisers covered by Annex I E to this Regulation containing one or more of the following micro-nutrients: boron, cobalt, copper, iron, manganese, molybdenum and zinc. It is applicable to each micro-nutrient the declared content of which is more than 10 %.

3. **Principle**

The micro-nutrients are extracted by shaking the fertiliser in water at 20 °C (± 2) °C.

Note

The extraction is empirical and may or may not be quantitative.

4. **Reagents**

4.1. *Dilute hydrochloric acid (HCl) solution, about 6 mol/l*

Mix 1 volume of hydrochloric acid ($d_{20} = 1,18$ g/ml) with 1 volume of water.

5. **Apparatus**

5.1. Rotary shaker set at about 35 to 40 rpm

Note

Where the boron content of the extract is to be determined, do not use borosilicate glassware. Teflon or silica is preferable for this extraction. Rinse the glassware thoroughly if it has been washed in detergents containing borates.

6. **Preparation of the sample**

See Method 1.

7. **Procedure**

7.1. *Test sample*

Take a quantity of fertiliser weighing 1 or 2 g depending on the declared content of the product. The following table shall be used to obtain a final solution which, after appropriate dilution, will be within the measuring range for each method. The samples should be weighed to within 1 mg.

Declared content of micro-nutrient in the fertiliser (%)	> 10 < 25	≥ 25
Mass of test sample (g)	2	1
Mass of element in the sample (mg)	> 200 < 500	≥ 250
Volume of extract V (ml)	500	500
Concentration of element in extract (mg/l)	> 400 < 1 000	≥ 500

Place the sample in a 500 ml flask.

7.2. *Preparation of the solution*

Add about 400 ml of water.

Stopper the flask well. Shake vigorously by hand to disperse the sample, then place the flask on the shaker and shake for 30 minutes.

Make up to volume with water and mix thoroughly.

7.3. *Preparation of the test solution*

Filter immediately into a clean, dry flask. Stopper the flask. Carry out the determination immediately after filtering.

Note

If the filtrate gradually becomes cloudy, make another extraction following 7.1 and 7.2 in a flask of volume V_e . Filter into a calibrated flask of volume W which has previously been dried and has received 5 ml of dilute hydrochloric acid (4.1). Stop the filtration at the exact moment when the calibration mark is reached. Mix thoroughly.

Under these conditions the value of V in the expression of results is:

$$V = V_e \times W / (W - 5)$$

The dilutions in the expression of results depend on this value of V .

8. Determination

The determination of each micro-nutrient is carried out on the aliquot portions indicated in the Method for each individual micro-nutrient.

Methods 10.5, 10.6, 10.7, 10.9 and 10.10 cannot be used to determine elements present in a chelated or complexed form. In such cases Method 10.3 must be used prior to the determination.

In the case of determination by AAS (Methods 10.8 and 10.11) such treatment may not be necessary.

Method 10.3**Removal of organic compounds from fertiliser extracts****1. Scope**

This Method defines a procedure for removing organic compounds from fertiliser extracts.

2. Field of application

This procedure is applicable to analysing samples of fertilisers extracted by Methods 10.1 and 10.2 for which a declaration of total and/or water-soluble element is required by Annex I E to this Regulation.

Note

The presence of small quantities of organic matter usually does not affect determination by means of atomic absorption spectrometry.

3. Principle

The organic compounds in an aliquot portion of the extract are oxidised with hydrogen peroxide.

4. Reagents**4.1. Dilute hydrochloric acid (HCl) solution, about 0,5 mol/l**

Mix 1 volume of hydrochloric acid ($d_{20} = 1,18$ g/ml) with 20 volumes of water.

4.2. Hydrogen peroxide solution (30 % H_2O_2 , $d_{20} = 1,11$ g/ml), free from micro-nutrients**5. Apparatus**

Electric hotplate with variable temperature control.

6. Procedure

Take 25 ml of the extract solution obtained by Method 10.1 or Method 10.2 and place in a 100 ml beaker. In the case of Method 10.2, add 5 ml of the dilute hydrochloric acid solution (4.1). Then add 5 ml of the hydrogen peroxide solution (4.2). Cover with a watch glass. Allow oxidation to occur at room temperature for about one hour, then bring gradually to boiling and boil for half an hour. If necessary, add a further 5 ml of the hydrogen peroxide to the solution once it has cooled. Then boil to remove the excess hydrogen peroxide. Allow to cool and transfer quantitatively to a 50 ml volumetric flask and make up to volume. Filter where necessary.

Account should be taken of this dilution when taking aliquot portions and calculating the percentage of micro-nutrient in the product.

Method 10.4

Determination of micro-nutrients in fertiliser extracts by atomic absorption spectrometry (general procedure)

1. Scope

This document defines a general procedure for determining the levels of iron and zinc in fertiliser extracts by atomic absorption spectrometry.

2. Field of application

This procedure is applicable to analysing samples of fertilisers extracted by Methods 10.1 and 10.2 for which a declaration of total and/or water-soluble iron or zinc is required by Annex I E to this Regulation.

Adaptations of this procedure for the various micro-nutrients are detailed in the methods defined specifically for each element.

Note

In most cases the presence of small quantities of organic matter will not affect determinations by atomic absorption spectrometry.

3. Principle

After the extract has been treated where necessary to reduce or eliminate interfering chemical species, the extract is diluted so that its concentration is in the optimum range of the spectrometer at a wavelength suitable for the micro-nutrient to be determined.

4. Reagents

4.1. Dilute hydrochloric acid solution (HCl), about 6 mol/l

Mix one volume of hydrochloric acid ($d_{20} = 1,18$ g/ml) with one volume of water.

4.2. Dilute hydrochloric acid solution (HCl), about 0,5 mol/l

Mix one volume of hydrochloric acid ($d_{20} = 1,18$ g/ml) with 20 volumes of water.

4.3. Lanthanum salt solutions (10 g of La per litre)

This reagent is used for determinations of iron and zinc. It can be prepared either:

(a) with lanthanum oxide dissolved in hydrochloric acid (4.1). Place 11,73 g of lanthanum oxide (La_2O_3) in 150 ml of water in a one litre volumetric flask and add 120 ml of 6 mol/l hydrochloric acid (4.1). Allow to dissolve and then make up to 1 litre with water and mix thoroughly. This solution is approximately 0,5 mol/l in hydrochloric acid; or

(b) with solutions of lanthanum chloride, sulphate or nitrate. Dissolve 26,7 g of lanthanum chloride heptahydrate ($\text{LaCl}_3 \cdot 7\text{H}_2\text{O}$) or 31,2 g of lanthanum nitrate hexahydrate [$\text{La}(\text{NO}_3)_3 \cdot 6\text{H}_2\text{O}$] or 26,2 g of lanthanum sulphate nonahydrate [$\text{La}_2(\text{SO}_4)_3 \cdot 9\text{H}_2\text{O}$] in 150 ml of water, then add 85 ml of 6 mol/l hydrochloric acid (4.1). Allow to dissolve and then make up to 1 litre with water. Mix thoroughly. This solution is approximately 0,5 mol/l in hydrochloric acid.

4.4. Calibration solutions

For the preparation of these, see the individual determination Method for each micro-nutrient.

5. Apparatus

Atomic absorption spectrometer fitted with sources emitting radiation characteristic of the micro-nutrients to be determined.

The analyst must follow the manufacturer's instructions and be familiar with the apparatus. The apparatus must allow background correction so that it can be used whenever necessary (e.g. Zn). The gases to be used are air and acetylene.

6. Preparation of the solution to be analysed

6.1. Preparation of extract solutions containing the elements to be determined

See Methods 10.1 and/or 10.2 and, if appropriate, 10.3.

6.2. Treatment of the test solution

Dilute an aliquot portion of the extract obtained by Method 10.1, 10.2 or 10.3 with water and/or hydrochloric acid (4.1) or (4.2) so as to obtain, in the final solution for measurement, a concentration of the element to be determined that is appropriate to the calibration range used (7.2) and a hydrochloric acid concentration of at least 0,5 mol/l and not more than 2,5 mol/l. This operation may require one or more successive dilutions.

The final solution has to be obtained by placing an aliquot portion of the diluted extract in a 100 ml volumetric flask. Let the volume of this aliquot portion be (a) ml. Add 10 ml of the lanthanum salt solution (4.3). Make up to volume with the 0,5 mol/l hydrochloric acid solution (4.2) and mix thoroughly. Let D be the dilution factor.

7. Procedure

7.1. Preparation of a blank solution

Prepare a blank solution by repeating the whole procedure from the extraction stage, omitting only the test sample of fertiliser.

7.2. Preparation of calibration solutions

From the working calibration solution prepared using the Method given for each individual micro-nutrient, prepare in 100 ml volumetric flasks a series of at least five calibration solutions of increasing concentration within the optimum measuring range of the spectrometer. If necessary, adjust the concentration of hydrochloric acid to bring it as close as possible to that of the diluted test solution (6.2). When determining iron or zinc, add 10 ml of the same lanthanum salt solution (4.3) as used in 6.2. Make up to volume with the 0,5 mol/l hydrochloric acid solution (4.2) and mix thoroughly.

7.3. Determination

Prepare the spectrometer (5) for the determination and adjust to the wavelength given in the Method for the individual micro-nutrient concerned.

Spray three times in succession the calibration solutions (7.2), the test solution (6.2) and the blank solution (7.1), noting each result and flushing the instrument with distilled water between individual sprayings.

Construct the calibration curve by plotting the average spectrometer reading for each calibration solution (7.2) along the ordinate and the corresponding concentration of the element, expressed in µg/ml, along the abscissa.

From this curve, determine the concentrations of the relevant micro-nutrient in the test solution x_s (6.2) and in the blank solution x_b (7.1), expressing these concentrations in µg per ml.

8. Expression of results

The percentage of micro-nutrient (E) in the fertiliser is given by:

$$E (\%) = [(x_s - x_b) \times V \times D] / (M \times 10^4)$$

If Method 10.3 has been used:

$$E (\%) = [(x_s - x_b) \times V \times 2D] / (M \times 10^4)$$

Where

E is the amount of the micro-nutrient determined, expressed as a percentage of the fertiliser;

x_s is the concentration of the test solution (6.2), in $\mu\text{g/ml}$;

x_b is the concentration of the blank solution (7.1), in $\mu\text{g/ml}$;

V is the volume of the extract obtained by Method 10.1 or 10.2, in ml;

D is the factor corresponding to the dilution carried out in 6.2;

M is the mass of the test sample taken in accordance with Method 10.1 or 10.2, in grams.

Calculation of dilution factor D:

If (a1), (a2), (a3),..., (ai) and (a) are the aliquot portions and (v1), (v2), (v3),..., (vi) and (100) are the volumes in ml corresponding to their respective dilutions, the dilution factor D will be equal to:

$$D = (v1/a1) \times (v2/a2) \times (v3/a3) \times \dots \times (vi/ai) \times (100/a)$$

Method 10.5

Determination of boron in fertiliser extracts by means of acidimetric titration

1. Scope

This Method defines a procedure for determining the boron content of fertiliser extracts.

2. Field of application

This procedure is applicable to extracts from samples of fertilisers obtained by Methods 10.1 or Method 10.2 and for which a declaration of total and/or water-soluble boron is required by Annex I E to this Regulation.

3. Principle

A mannitoboric complex is formed by the following reaction of the borate with mannitol:



The complex is titrated with sodium hydroxide solution to a pH of 6,3.

4. Reagents

4.1. Methyl red indicator solution

Dissolve 0,1 g of methyl red ($\text{C}_{15}\text{H}_{15}\text{N}_3\text{O}_2$) in 50 ml of ethanol (95 % in a 100 ml volumetric flask). Make up the volume to 100 ml with water. Mix thoroughly.

4.2. Diluted hydrochloric acid solution, about 0,5 mol

Mix 1 volume of hydrochloric acid HCl ($d_{20} = 1,18 \text{ g/ml}$) with 20 volumes of water.

4.3. Sodium hydroxide solution, about 0,5 mol/l

Must be free of carbon dioxide. Dissolve 20 g of sodium hydroxide (NaOH) in pellet form in a 1 litre volumetric flask containing about 800 ml of boiled water. When the solution has cooled, make up to 1 000 ml with boiled water and mix thoroughly.

4.4. Standard sodium hydroxide solution, about 0,025 mol/l

Must be free of carbon dioxide. Dilute the 0,5 mol/l sodium hydroxide solution (4.3) 20 times with boiled water and mix thoroughly. The value of the solution expressed as boron (B) is to be determined (see Paragraph 9).

4.5. Boron calibration solution (100 $\mu\text{g/ml}$ B)

Dissolve 0,5719 g of boric acid (H_3BO_3), weighed to the nearest 0,1 mg, in water in a 1,000 ml volumetric flask. Make up to volume with water and mix thoroughly. Transfer to a plastic bottle for storage in a refrigerator.

4.6. D-mannitol (C₆H₁₄O₆) powder

4.7. Sodium chloride (NaCl)

5. **Apparatus**

5.1. pH meter with glass electrode

5.2. Magnetic stirrer

5.3. 400 ml beaker with teflon rod

6. **Preparation of the solution to be analysed**

6.1. *Preparation of the boron solution*

See Methods 10.1, 10.2 and, where appropriate, 10.3.

7. **Procedure**

7.1. *Test*

Place in a 400 ml beaker (5.3) an aliquot (a) of the extract (6.1) containing 2 to 4 mg B. Add 150 ml of water.

Add several drops of the methyl red indicator solution (4.1).

In the case of extraction with Method 10.2, acidify by adding 0,5 mol/l hydrochloric acid (4.2) up to the point of change of the indicator solution, then add a further 0,5 ml of 0,5 mol/l hydrochloric acid (4.2).

After adding 3 g of sodium chloride (4.7), bring to boiling to drive off the carbon dioxide. Allow to cool. Place the beaker on the magnetic stirrer (5.2) and insert the precalibrated pH meter electrodes (5.1).

Adjust the pH to exactly 6,3, first with the 0,5 mol/l sodium hydroxide solution (4.3), then with the 0,025 mol/l solution (4.4).

Add 20 g of D-mannitol (4.6), dissolve completely and mix thoroughly. Titrate with the 0,025 mol/l sodium hydroxide solution (4.4) to pH 6,3 (at least 1 minute stability). Let X₁ be the volume required.

8. **Blank solution**

Prepare a blank solution by repeating the whole procedure from the preparation of solution stage, omitting only the fertiliser. Let X₀ be the volume required.

9. **Boron (B) value of the sodium hydroxide solution (4.4)**

Pipette 20 ml (2,0 mg B) of the calibration solution (4.5), into a 400 ml beaker and add several drops of methyl red indicator solution (4.1). Add 3 g of sodium chloride (4.7) and the hydrochloric acid solution (4.2) up to the point of change of the indicator solution (4.1).

Make up the volume to about 150 ml and bring gradually to the boil so as to eliminate carbon dioxide. Allow to cool. Place the beaker on the magnetic stirrer (5.2), and insert the precalibrated pH meter electrodes (5.1). Adjust the pH to exactly 6,3, first with the 0,5 mol/l sodium hydroxide solution (4.3), then with the 0,025 mol/l solution (4.4).

Add 20 g of D-mannitol (4.6), dissolve completely and mix thoroughly. Titrate with the 0,025 mol/l sodium hydroxide solution (4.4) to pH 6,3 (at least 1 minute stability). Let V₁ be the volume required.

Prepare a blank solution in the same way, substituting 20 ml of water for the calibration solution. Let V₀ be the volume required.

The boron value (F) in mg/ml of the standard NaOH solution (4.4) is as follows:

$$F \text{ (in mg/ml)} = 2 / (V_1 - V_0)$$

1 ml of exactly 0,025 mol/l sodium hydroxide solution corresponds to 0,27025 mg B.

10. Expression of results

The percentage of boron in the fertiliser is given by:

$$B (\%) = \frac{(X_1 - X_0) \times F \times V}{10 \times a \times M}$$

where

B (%) is the percentage of boron in the fertiliser;

X₁ is the volume, in ml, of the 0,025 mol/l sodium hydroxide solution (4.4); needed for the test solution;

X₀ is the volume, in ml, of the 0,025 mol/l sodium hydroxide solution (4.4); needed for the blank solution;

F is the boron (B) value, in mg/ml, of the 0,025 mol/l sodium hydroxide solution mol/l (4.4);

V is the volume, in ml, of the extract solution obtained in accordance with Method 10.1 or 10.2;

a is the volume, in ml, of the aliquot (7.1) taken from the extract solution (6.1);

M is the mass, in grams, of the test sample taken in accordance with Method 10.1 or 10.2.

Method 10.6

Determination of cobalt in fertiliser extracts by the gravimetric method with 1-nitroso-2-naphthol

1. Scope

This document defines a procedure for determining cobalt in fertiliser extracts.

2. Field of application

This procedure is applicable to extracts from samples of fertilisers obtained by Method 10.1 or Method 10.2 for which a declaration of cobalt content is required by Annex I E to this Regulation.

3. Principle

Cobalt III combines with 1-nitroso-2-naphthol to give a red precipitate $\text{Co}(\text{C}_{10}\text{H}_6\text{ONO})_3 \cdot 2\text{H}_2\text{O}$. After the cobalt present in the extract has been brought to the cobalt III state, the cobalt is precipitated in an acetic acid medium by a solution of 1-nitroso-2-naphthol. After filtration, the precipitate is washed and dried to constant mass and then weighed as $\text{Co}(\text{C}_{10}\text{H}_6\text{ONO})_3 \cdot 2\text{H}_2\text{O}$.

4. Reagents

4.1. Hydrogen peroxide solution (H_2O_2 , $d_{20} = 1,11$ g/ml) 30 %

4.2. Sodium hydroxide solution, about 2 mol/l

Dissolve 8 g of sodium hydroxide in pellet form in 100 ml of water.

4.3. Diluted hydrochloric acid solution, about 6 mol/l

Mix one volume of hydrochloric acid ($d_{20} = 1,18$ g/ml) with 1 volume of water.

4.4. Acetic acid (99,7 % $\text{CH}_3\text{CO}_2\text{H}$) ($d_{20} = 1,05$ g/ml)

4.5. Acetic acid solution (1:2), about 6 mol/l

Mix one volume of acetic acid (4.4) with 2 volumes of water.

4.6. Solution of 1-nitroso-2-naphthol in 100 ml of acetic acid (4.4). Add 100 ml of lukewarm water. Mix thoroughly. Filter at once. The solution obtained must be used immediately

5. Apparatus

5.1. Filter crucible P 16/ISO 4 793, porosity 4, capacity 30 or 50 ml

5.2. Drying oven at 130 (± 2) °C

6. Preparation of the solution to be analysed

6.1. *Preparation of the cobalt solution*

See Methods 10.1 or 10.2.

6.2. *Preparation of the solution to be analysed*

Place an aliquot of the extract containing not more than 20 mg Co in a 400 ml beaker. If the extract is obtained according to Method 10.2, acidify with five drops of hydrochloric acid (4.3). Add about 10 ml of the hydrogen peroxide solution (4.1). Allow the oxidant to act in the cold state for 15 minutes, then make up to about 100 ml with water. Cover the beaker with a watch glass. Bring the solution to boiling point and allow to boil for about 10 minutes. Cool. Make alkaline with the sodium hydroxide solution (4.2) drop by drop until black cobalt hydroxide begins to precipitate.

7. Procedure

Add 10 ml of acetic acid (4.4) and make up the solution with water to about 200 ml. Heat until boiling. Using a burette, add 20 ml of the 1-nitroso-2-naphthol solution (4.6) drop by drop, stirring constantly. Complete by vigorous stirring to make the precipitate coagulate.

Filter through a previously weighed filter crucible (5.1), taking care not to clog up the crucible. With this in mind, ensure that liquid is left above the precipitate throughout the filtration process.

Wash the beaker with dilute acetic acid (4.5) to remove all the precipitate, wash the precipitate on the filter with dilute acetic acid (4.5) and then three times with hot water.

Dry in a drying oven (5.2) at 130 (± 2) °C until constant mass is achieved.

8. Expression of the results

1 mg of Co ($C_{10}H_6ONO)_3 \cdot 2H_2O$ precipitate corresponds to 0,096381 mg Co.

The percentage of Cobalt (Co) in the fertiliser is given by:

$$\text{Co (\%)} = X \times 0,0096381 \times \frac{V \times D}{a \times M}$$

where

X is the mass in mg of the precipitate;

V is the volume in ml of the extract solution obtained in accordance with Method 10.1 or Method 10.2;

a is the volume in ml of the aliquot taken from the last dilution;

D is the dilution factor of this aliquot;

M is the mass in g of the test sample.

Method 10.7**Determination of copper in fertiliser extracts by the titrimetric method****1. Scope**

This document defines a procedure for determining copper in fertiliser extracts.

2. Field of application

This procedure is applicable to extracts from samples of fertilisers obtained by Method 10.1 or Method 10.2 for which a declaration of copper content is required by Annex IE to this Regulation.

3. Principle

The cupric ions are reduced in an acidic medium with potassium iodide:

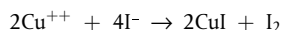

The iodine released in this way is titrated with a standard sodium thiosulphate solution in the presence of starch as an indicator in accordance with:

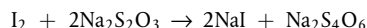

4. Reagents

4.1. Nitric acid (HNO_3 , $d_{20} = 1,40$ g/ml)

4.2. Urea [$(\text{NH}_2)_2\text{C} = \text{O}$]

4.3. Ammonium bifluoride (NH_4HF_2) solution 10 % w/v

Keep the solution in a plastic container.

4.4. Ammonium hydroxide solution (1 + 1)

Mix 1 volume of ammonia (NH_4OH , $d_{20} = 0,9$ g/ml) with 1 volume of water.

4.5. Sodium thiosulphate standard solution

Dissolve 7,812 g of sodium thiosulphate pentahydrate ($\text{Na}_2\text{S}_2\text{O}_3 \cdot 5\text{H}_2\text{O}$) with water in a 1 litre volumetric flask. This solution must be prepared so that 1 ml = 2 mg Cu. For stabilisation, add several drops of chloroform. The solution must be kept in a glass container and protected from direct light.

4.6. Potassium iodide (KI)

4.7. Potassium thiocyanate (KSCN) solution (25 % w/v)

Keep this solution in a plastic flask.

4.8. Starch solution (about 0,5 %)

Place 2,5 g of starch in a 600 ml beaker. Add about 500 ml of water. Boil while stirring. Cool to ambient temperature. The solution has a short preservation period. Its preservation can be extended by adding about 10 mg of mercury iodide.

5. Preparation of the solution to be analysed

Preparation of the copper solution

See Methods 10.1 and 10.2.

6. Procedure

6.1. Preparation of the solution of titration

Place an aliquot portion of the solution containing not less than 20-40 mg Cu in a 500 ml Erlenmeyer flask.

Drive off any excess oxygen present by boiling briefly. Make up to a volume of about 100 ml water. Add 5 ml of nitric acid (4.1), bring to boiling and allow to boil for about half a minute.

Remove the Erlenmeyer flask from the heating apparatus, add about 3 g of urea (4.2) and resume boiling for about half a minute.

Remove from the heating apparatus and add 200 ml of cold water. Where necessary, cool the contents of the Erlenmeyer flask to ambient temperature.

Gradually add ammonia hydroxide solution (4.4) until the solution becomes blue, then add 1 ml in excess.

Add 50 ml of ammonium bifluoride solution (4.3) and mix.

Add 10 g of potassium iodide (4.6) and dissolve.

6.2. *Titration of the solution*

Place the Erlenmeyer flask on a magnetic stirrer. Insert the rod into the Erlenmeyer flask and adjust the stirrer to the desired speed.

Using a burette, add standard sodium thiosulphate solution (4.5) until the brown colour of the iodine released from the solution becomes less intense.

Add 10 ml of the starch solution (4.8).

Continue to titrate with the sodium thiosulphate solution (4.5) until the purple colour has almost disappeared.

Add 20 ml of the potassium thiocyanate solution (4.7) and continue titration until the violet blue colour has completely disappeared.

Note the volume for thiosulphate solution employed.

7. **Expression of results**

1 ml of standard sodium thiosulphate solution (4.5) corresponds to 2 mg Cu.

The percentage of copper in the fertiliser is given by:

$$\text{Cu (\%)} = X \frac{V}{a \times M \times 5}$$

where

X is the volume in ml of the sodium thiosulphate solution used;

V is the volume in ml of the extract solution in accordance with Methods 10.1 and 10.2;

a is the volume in ml of the aliquot portion;

M is the mass in g of the test sample treated in accordance with Methods 10.1 and 10.2.

Method 10.8

Determination of iron in fertiliser extracts by atomic absorption spectrometry

1. **Scope**

This Method describes a procedure for determining iron in fertiliser extracts.

2. **Field of application**

This procedure is applicable to extracts from samples of fertilisers obtained by Methods 10.1 and 10.2 for which a declaration of total and/or water-soluble iron is required by Annex I E to this Regulation.

3. **Principle**

After suitable treatment and dilution of the extract, the iron content is determined by atomic absorption spectrometry.

4. **Reagents**

4.1. *Hydrochloric acid solution, about 6 mol/l*

See Method 10.4 (4.1).

4.2. *Hydrochloric acid solution, about 0,5 mol/l*

See Method 10.4 (4.2).

- 4.3. Hydrogen peroxide solution (30 % H₂O₂, d₂₀ = 1,11 g/ml) free from micro-nutrients
- 4.4. *Lanthanum salt solutions (10 g of La per litre)*
See Method 10.4 (4.3).
- 4.5. *Iron calibration solution*
- 4.5.1. Iron stock solution (1 000 µg/ml)
In a 500 ml beaker, weigh to the nearest 0,1 mg, 1 g of pure iron wire, add 200 ml of 6 mol/l hydrochloric acid (4.1) and 15 ml of hydrogen peroxide solution (4.3). Heat on a hotplate until the iron is completely dissolved. When cool, transfer quantitatively to a 1 000 ml volumetric flask. Make up to volume with water and mix thoroughly.
- 4.5.2. Iron working solution (100 µg/ml)
Place 20 ml of the stock solution (4.5.1) in a 200 ml volumetric flask. Make up to volume with the 0,5 mol/l hydrochloric acid solution (4.2) and mix thoroughly.
5. **Apparatus**
Atomic absorption spectrometer: see Method 10.4 (5). The instrument must be fitted with a source of emitted radiation characteristic of iron (248,3 nm).
6. **Preparation of the solution to be analysed**
- 6.1. *Iron extract solution*
See Methods 10.1 and/or 10.2 and, if appropriate, 10.3.
- 6.2. *Preparation of the test solution*
See Method 10.4 (6.2). The test solution must contain 10 % (v/v) of a lanthanum salt solution.
7. **Procedure**
- 7.1. *Preparation of blank solution*
See Method 10.4 (7.1). The blank solution must contain 10 % (v/v) of the lanthanum salt solution used in 6.2.
- 7.2. *Preparation of calibration solutions*
See Method 10.4 (7.2).

For an optimum determination range of 0 to 10 µg/ml of iron, place 0, 2, 4, 6, 8 and 10 ml respectively of working solution (4.5.2) in a series of 100 ml volumetric flasks. If necessary adjust the hydrochloric acid concentration as closely as possible to that of the test solution. Add 10 ml of the lanthanum salt solution used in 6.2. Make up to volume with 0,5 mol/l hydrochloric acid solution (4.2) and mix thoroughly. These solutions contain 0, 2, 4, 6, 8 and 10 µg/ml respectively of iron.
- 7.3. *Determination*
See Method 10.4 (7.3). Prepare the spectrometer (5) for measurement at a wavelength of 248,3 nm.
8. **Expression of results**
See Method 10.4 (8).

The percentage of iron in the fertiliser is given by:

$$\text{Fe (\%)} = [(x_s - x_b) \times V \times D] / (M \times 10^4)$$

If Method 10.3 is used:

$$\text{Fe (\%)} = [(x_s - x_b) \times V \times 2D] / (M \times 10^4)$$

Where

Fe is the quantity of iron expressed as a percentage of the fertiliser;

x_s is the concentration in $\mu\text{g/ml}$ of the test solution (6.2);

x_b is the concentration in $\mu\text{g/ml}$ of the blank solution (7.1);

V is the volume in ml of extract obtained in accordance with Method 10.1 or 10.2;

D is the factor of dilution carried out in 6.2;

M is the mass in grams of the test sample taken in accordance with Method 10.1 or 10.2.

Calculation of the dilution factor D: if (a_1) , (a_2) , (a_3) , ..., (a_i) and (a) are aliquot portions and (v_1) , (v_2) , (v_3) , ..., (v_i) and (100) are the volumes in ml corresponding to their respective dilutions, the dilution factor D is given by:

$$D = (v_1/a_1) \times (v_2/a_2) \times (v_3/a_3) \times \dots \times (v_i/a_i) \times (100/a)$$

Method 10.9

Determination of manganese in fertiliser extracts by titration

1. Scope

This Method describes a procedure for determining manganese in fertiliser extracts.

2. Field of application

This procedure is applicable to extracts from samples of fertilisers obtained by Methods 10.1 and 10.2 for which a declaration of manganese is required by Annex I E to this.

3. Principle

If chloride ions are present in the extract, they are driven off by boiling the extract with sulphuric acid. The manganese is oxidised by sodium bismuthate in a nitric acid medium. The permanganate formed is reduced by an excess of ferrous sulphate. This excess is titrated with a potassium permanganate solution.

4. Reagents

4.1. Concentrated sulphuric acid (H_2SO_4 , $d_{20} = 1,84 \text{ g/ml}$)

4.2. Sulphuric acid, about 9 mol/l

Carefully mix 1 volume of concentrated sulphuric acid (4.1) with 1 volume of water.

4.3. Nitric acid, 6 mol/l

Mix 3 volumes of nitric acid (HNO_3 , $d_{20} = 1,40 \text{ g/ml}$) with 4 volumes of water.

4.4. Nitric acid, 0,3 mol/l

Mix 1 volume of 6 mol/l nitric acid with 19 volumes of water.

4.5. Sodium bismuthate (NaBiO_3) (85 %).

4.6. Kieselguhr

4.7. Orthophosphoric acid, 15 mol/l (H_3PO_4 , $d_{20} = 1,71 \text{ g/ml}$)

4.8. Ferrous sulphate solution, 0,15 mol/l

Dissolve 41,6 g of ferrous sulphate heptahydrate ($\text{FeSO}_4 \cdot 7\text{H}_2\text{O}$) in a 1 litre volumetric flask.

Add 25 ml of concentrated sulphuric acid (4.1) and 25 ml phosphoric acid (4.7). Make up to 1 000 ml. Mix.

4.9. *Potassium permanganate solution, 0,020 mol/l*

Weigh out 3,160 g of potassium permanganate (KMnO₄) to within 0,1 mg. Dissolve and make up to 1 000 ml with water.

4.10. *Silver nitrate solution, 0,1 mol/l*

Dissolve 1,7 g of silver nitrate (AgNO₃) in water and make up to 100 ml.

5. **Apparatus**

5.1. Filter crucible P16/ISO 4 793, porosity 4, capacity 50 ml, mounted on a 500 ml filtration flask.

5.2. Magnetic stirrer

6. **Preparation of the solution to be analysed**6.1. *Manganese extract solution*

See Methods 10.1 and 10.2. If it is not known whether chloride ions are present, perform a test on the solution with one drop of the silver nitrate solution (4.10).

6.2. In the absence of chloride ions, place an aliquot of the extract containing 10 to 20 mg of manganese in a tall form 400 ml beaker. Bring to a volume of about 25 ml either by evaporation or by adding water. Add 2 ml of concentrated sulphuric acid (4.1)

6.3. *If chloride ions are present, it is necessary to remove them as follows*

Place an aliquot of the extract containing 10 to 20 mg of manganese in a tall form 400 ml beaker. Add 5 ml of 9 mol/l sulphuric acid (4.2). Under a fume hood, bring to boiling on a hotplate and allow to boil until copious white fumes are released. Continue until the volume is reduced to about 2 ml (thin film of syrupy liquid at the bottom of the beaker). Allow to cool to ambient temperature.

Carefully add 25 ml of water and once again test for the presence of chlorides with one drop of the silver nitrate solution (4.10). If chlorides still remain, repeat the operation after adding 5 ml of 9 mol/l sulphuric acid (4.2).

7. **Procedure**

Add 25 ml of 6 mol/l nitric acid (4.3) and 2,5 g of sodium bismuthate (4.5) to the 400 ml beaker containing the test solution. Stir vigorously for three minutes on the magnetic stirrer (5.2).

Add 50 ml of 0,3 mol/l nitric acid (4.4) and stir again. Filter in vacuo through a crucible (5.1), the bottom of which is covered with Kieselguhr (4.6). Wash the crucible several times with the 0,3 mol/l nitric acid (4.4) until a colourless filtrate is obtained.

Transfer the filtrate and the washing solution into a 500 ml beaker. Mix and add 25 ml of 0,15 mol/l ferrous sulphate solution (4.8). If the filtrate turns yellow after the addition of ferrous sulphate, add 3 ml of 15 mol/l orthophosphoric acid (4.7).

Using a burette, titrate the excess ferrous sulphate with 0,02 mol/l potassium permanganate solution (4.9) until the mixture turns pink, the colour remaining stable for one minute. Perform a blank test under the same conditions, omitting only the test sample.

Note

The oxidised solution must not come into contact with rubber.

8. **Expression of results**

1 ml of 0,02 mol/l potassium permanganate solution corresponds to 1,099 mg of manganese (Mn).

The percentage of manganese in the fertiliser is given by:

$$\text{Mn (\%)} \text{ where } = (x_b - x_s) \times 0,1099 \times \frac{V}{a \times M}$$

Where

x_b is the volume in ml of the permanganate used for the blank;

x_s is the volume in ml of the permanganate used for the test sample;

V is the volume in ml of the extract solution in accordance with Methods 10.1 and 10.2;

a is the volume in ml of the aliquot portion taken from the extract;

M is the mass in g of the test sample.

Method 10.10

Determination of molybdenum in fertiliser extracts by the gravimetric method with 8-Hydroxyquinoline

1. Scope

This document describes a procedure for determining molybdenum in fertiliser extracts.

2. Field of application

This procedure is applicable to extracts from samples of fertilisers obtained by Methods 10.1 and 10.2 for which a declaration of molybdenum is required by Annex I E to this Regulation.

3. Principle

The molybdenum level is determined by precipitation as molybdenyl oxinate under specific conditions.

4. Reagents

4.1. Sulphuric acid solution, approximately 1 mol/l

Carefully pour 55 ml of sulphuric acid (H_2SO_4 , $d_{20} = 1,84$ g/ml) into a 1 litre volumetric flask containing 800 ml of water. Mix. After cooling, make up to one litre. Mix.

4.2. Diluted ammonia solution (1: 3)

Mix 1 volume of concentrated ammonia solution (NH_4OH , $d_{20} = 0,9$ g/ml) with 3 volumes of water.

4.3. Diluted acetic acid solution (1: 3)

Mix 1 volume of concentrated acetic acid (99,7 % CH_3COOH , $d_{20} = 1,049$ g/ml) with 3 volumes of water.

4.4. Solution of disodium salt of ethylene diamine tetraacetic acid (EDTA)

Dissolve 5 g of Na_2EDTA in water in a 100 ml volumetric flask. Make up to the calibration mark and mix.

4.5. Buffer solution

In a 100 ml volumetric flask, dissolve 15 ml of concentrated acetic acid and 30 g of ammonium acetate in water. Make up to 100 ml.

4.6. 7-Hydroxyquinoline (oxine) solution

In a 100 ml volumetric flask, dissolve 3 g of 8-Hydroxyquinoline in 5 ml of concentrated acetic acid. Add 80 ml of water. Add the ammonia solution (4.2) drop by drop until the solution becomes cloudy and then add the acetic acid (4.3) until the solution becomes clear again.

Make up to 100 ml with water.

5. Apparatus

5.1. Filter crucible P16/ISO 4 793, porosity 4, capacity 30 ml

- 5.2. pH meter with glass electrode
- 5.3. Drying oven at 130 to 135 °C
6. **Preparation of the solution to be analysed**
- 6.1. Preparation of the molybdenum solution. See Method 10.1 and Method 10.2
7. **Procedure**
- 7.1. *Preparation of the test solution*
- Place an aliquot portion containing 25 to 100 mg Mo in a 250 ml beaker. Make up the volume to 50 ml with water.
- Adjust this solution to pH of 5 by adding the sulfuric acid solution (4.1) drop by drop. Add 15 ml of EDTA solution (4.4) and then 5 ml of buffer solution (4.5). Make up to about 80 ml with water.
- 7.2. *Obtaining and washing the precipitate*
- Obtaining the precipitate
- Heat the solution slightly. Stirring constantly, add the oxine solution (4.6). Continue the precipitation until formation of a deposit is no longer observed. Add further reagent until the supernatant solution turns slightly yellow. A quantity of 20 ml should normally be sufficient. Continue to heat the precipitate slightly for two or three minutes.
- Filtration and washing
- Filter through a filter crucible (5.1). Rinse several times with 20 ml of hot water. The rinse water should gradually become colourless indicating that oxine is not longer present.
- 7.3. *Weighing the precipitate*
- Dry the precipitate at 130 to 135 °C to constant mass (at least one hour).
- Allow to cool in a desiccator and then weigh.
8. **Expression of the results**
- 1 mg of molybdenyl oxinate, $\text{MoO}_2(\text{C}_9\text{H}_6\text{ON})_2$, corresponds to 0,2305 mg Mo.
- The percentage of molybdenum in the fertiliser is given by:

$$\text{Mo (\%)} = X \times 0,02305 \times \frac{V \times D}{a \times M}$$

Where

X is the mass in mg of the molybdenyl oxinate precipitate;

V is the volume in ml of the extract solution in accordance with Methods 10.1 or 10.2;

a is the volume in ml of the aliquot taken from the last dilution;

D is the dilution factor of the aliquot;

M is the mass in g of the test sample.

Method 10.11

Determination of zinc in fertiliser extracts by atomic absorption spectrometry

1. Scope

This Method describes a procedure for determining zinc in fertiliser extracts.

2. Field of application

This procedure is applicable to extracts from samples of fertilisers obtained by Methods 10.1 and 10.2 for which a declaration of zinc is required by Annex I E to this Regulation.

3. Principle

After suitable treatment and dilution of the extracts, the zinc level is determined by atomic absorption spectrometry.

4. Reagents

4.1. Hydrochloric acid solution, about 6 mol/l

See Method 10.4 (4.1).

4.2. Hydrochloric acid solution, about 0,5 mol/l

See Method 10.4 (4.2).

4.3. Lanthanum salt solutions (10 g of La per litre)

See Method 10.4 (4.3).

4.4. Zinc calibration solutions

4.4.1. Zinc stock solution (1 000 µg/ml)

In a 1 000 ml volumetric flask, dissolve 1 g of zinc powder or flakes weighed to within 0,1 mg in 25 ml of 6 mol/l hydrochloric acid (4.1). When completely dissolved, make up to volume with water and mix thoroughly.

4.4.2. Zinc working solution (100 µg/ml)

In a 200 ml volumetric flask, dilute 20 ml of the stock solution (4.4.1) in 0,5 mol/l hydrochloric acid solution (4.2). Make up to a volume with the 0,5 mol/l hydrochloric acid solution and mix thoroughly.

5. Apparatus

Atomic absorption spectrometer.

See Method 10.4 (5). The apparatus must be fitted with a source of lines characteristic of zinc (213,8 nm). The spectrometer must allow background correction to be made.

6. Preparation of the solution to be analysed

6.1. Zinc extract solution

See Method 10.1 and/or 10.2.

6.2. Preparation of the test solution

See Method 10.4 (6.2). The test solution must contain 10 % by volume of lanthanum salt solution (4.3).

7. Procedure

7.1. Preparation of the blank solution

See Method 10.4 (7.1). The blank solution must contain 10 % by volume of the lanthanum salt solution used in 6.2.

7.2. Preparation of the calibration solutions

See Method 10.4 (7.2). For an optimum interval of 0 to 5 µg/ml of zinc, place 0, 0,5, 1, 2, 3, 4 and 5 ml, respectively, of the working solution (4.4.2) in a series of 100 ml volumetric flasks. Where necessary, adjust the concentration of hydrochloric acid to bring it as close as possible to that of the test solution. Add 10 ml of the lanthanum salt solution used in (6.2) to each volumetric flask. Make up to 100 ml with the 0,5 mol/l hydrochloric acid solution (4.2) and mix thoroughly.

These solutions contain, respectively, 0, 0,5, 1, 2, 3, 4 and 5 µg/ml of zinc.

7.3. Determination

See Method 10.4 (7.3). Prepare the spectrometer (5) for measurements at a wavelength of 213,8 nm.

8. Expression of results

See Method 10.4 (8).

The percentage of zinc in the fertiliser is given by:

$$\text{Zn (\%)} = [(x_s - x_b) \times V \times D] / (M \times 10^4)$$

If Method 10.3 has been used:

$$\text{Zn (\%)} = [(x_s - x_b) \times V \times 2D] / (M \times 10^4)$$

Where

Zn is the quantity of zinc expressed as a percentage of the fertiliser;

x_s is the concentration in $\mu\text{g/ml}$ of the test solution;

x_b is the concentration in $\mu\text{g/ml}$ of the blank solution;

V is the volume in ml of the extract solution obtained in accordance with Method 10.1 or 10.2;

D is the factor corresponding to the dilution performed in (6.2);

M is the mass in g of the test sample taken in accordance with Method 10.1 or 10.2.

Calculation of the dilution factor D:

where (a1), (a2), (a3), ..., (ai) and (a) are successive aliquot portions and (v1), (v2), (v3), ..., (vi) and (100) are the volumes in ml corresponding to their respective dilutions, the dilution factor D is given by:

$$D = (v1/a1) \times (v2/a2) \times (v3/a3) \times \dots \times (vi/ai) \times (100/a)$$

ANNEX V

A. LIST OF DOCUMENTS TO BE CONSULTED BY MANUFACTURERS OR THEIR REPRESENTATIVES IN ORDER TO COMPILE A TECHNICAL FILE FOR A NEW TYPE OF FERTILISERS TO BE ADDED TO ANNEX I OF THIS REGULATION

1. Guide to the compilation of a technical file on application to designate fertilisers 'EC fertiliser'.

Official Journal of the European Communities, C 138 of 20.5.1994, p. 4.

2. Commission Directive 91/155/EEC of 5 March 1991 on defining and laying down the detailed arrangements for the system of specific information relating to dangerous preparations in implementation of Article 10 of Directive 88/379/EEC.

Official Journal of the European Communities, L 76/35 of 22.3.1991, p. 35.

3. Commission Directive 93/112/EC of 10 December 1993 on amending Commission Directive 91/155/EEC defining and laying down detailed arrangements for the system of specific information relating to dangerous preparations in implementation of Article 10 of Council Directive 88/379/EEC.

Official Journal of the European Communities, L 314 of 16.12.1993, p. 38.

B. STANDARDS OF ACCREDITATION CONCERNING THE LABORATORIES THAT ARE COMPETENT TO PROVIDE THE NECESSARY SERVICE FOR CHECKING COMPLIANCE OF EC FERTILISERS WITH THE REQUIREMENTS OF THIS REGULATION AND ITS ANNEXES

1. Standard applicable at the level of the laboratories:

EN ISO/IEC 17025, General requirements for the competence of testing and calibration laboratories.

2. Standard applicable at the level of the accreditation bodies:

EN 45003, Calibration and testing laboratory accreditation system, general requirements for operation and recognition.
