

FOOD ADDITIVES CODE

Ministry of Food and Drug Safety Regulation #2019-63(2019.7.25)

I. General Rules

1. Purpose

The purpose of this regulation is to secure safe-quality of food additives and to contribute to public health in using them in food safely through establishing the Standards and Specifications of manufacturing, processing, using and preserving of the food additives according the Article 7 (1) of the Food Sanitation Act.

2. Definition of Terms

- 1) "Processing aid" means food additive that is intentionally used to fulfil a certain technological purpose during food manufacturing process, and which may fully be degraded before the final product is completed, be removed so that does not remain, or be result in unavoidable presence of residues or derivatives in the final product. 'Sterilizing agent', 'Filter aid', 'Release agent', 'Manufacturing solvent', 'Boiler Water Additive', 'Extraction solvent' and 'Enzyme preparations' of major functional classes are belong to processing aid.
- 2) "Functional classes" of food additives are technological effects of them occurring to food in food manufacturing or processing. and definition of each term is as follows.
 - (1) "Sweetener" is a food additive, which imparts a sweet taste to a food.
 - (2) "Anticaking agent" is a food additive, which reduces the tendency of components of food to adhere to one another.
 - (3) "Antifforming agent" is a food additive, which prevents or reduces foaming.
 - (4) "Gum base" is a food additive, which is a non-nutritive chewing substance with moderate viscosity and elasticity and is a basic material of gum manufacturing.
 - (5) "Flour treatment agent" is a food additive, which makes it possible to form or maintain a uniform dispersion of a gaseous phase in a liquid or solid food.
 - (6) "Color retention agent" is a food additive, which stabilizes, retains or intensifies the colour of a food.

- (7) "Preservative" is a food additive, which prolongs the shelf-life of a food by protecting against deterioration caused by microorganisms.
- (8) "Propellant" is a food additive, which expels a food from a container.
- (9) "Acidity regulator" is a food additive, which controls the acidity or alkalinity of a food.
- (10) "Antioxidant" is a food additive, which prolongs the self-life of foods by protecting against deterioration caused by oxidation.
- (11) "Sterilizing agent" is a food additive, which extinct microorganisms on food surface in a short time.
- (12) "Humectant" is a food additive, which prevents food from drying out by counteracting the effect of a dry atmosphere.
- (13) "Stabilizer" is a food additive, which makes it possible to maintain a uniform dispersion of two or more components.
- (14) "Filter aid" is a food additive, which eliminate impurities or minute particles by absorption.
- (15) "Fortifying nutrient" is a food additive, which restore the nutrients lost during the manufacturing process to maintain nutritional quality of the food, or strengthen
- (16) "Emulsifier" is a food additive, which forms or maintains a uniform emulsion of two or more phases in a food.
- (17) "Release agent" is a food additive, which makes raw materials easily separate from containers by keeping them in shape.
- (18) "Firming agent" is a food additive, which makes or keeps tissues of fruit or vegetables firm and crisp, or interacts with gelling agents to produce or strengthen a gel.
- (19) "Manufacturing solvent" is a food additive, which aid in food manufacturing or processing by catalyst, sedimentation, decomposition or clarifying.
- (20) "Gelling agent" is a food additive, which gives a food texture through formation of a gel.
- (21) "Thickener" is a food additive, which increases the viscosity of a food.

<MFDS's Regulation #2017-100, 2017.12.11.> [Date of entry into force 2019.1.1.]

- (23) "Boiler Water Additive" is a food additive that is added to prevent the formation of stones, residue of water, corrosion, and etc. in the boiler that produces steam in direct contact with food.
- (22) "Colour" is a food additive, which adds or restores colour in a food.
- (24) "Extraction solvent" is a food additive, which extract or dissolve useful component and etc.
- (25) "Packaging gas" is a food additive gas, which is introduced into a container before, during or after filling with food with the intention to protect the food, for example, from oxidation or spoilage.
- (26) "Raising agent" is a food additive or a combination of food additives, which liberate(s) gas and thereby increase(s) the volume of a dough or batter.
- (27) "Bleaching agent" is a food additive(non-flour use) used to decolourize food. Beaching agents do not include pigments.
- (28) "Surface-finishing agent" is a food additive, which when applied to the external surface of a food, smoother or tidying up the food surface.

- (29) "Coating agent" is a food additive, when applied to the external surface of a food, which imparts a shiny appearance or provides a protective coating.
- (30) "Flavour enhancer" is a food additive, which enhances the existing taste and/or odour of a food.
- (31) "Flavouring agent" is a food additive, which give a unique flavour to food or reinforce the original fragrance which was lost during the manufacturing process.
- (32) "Enzyme preparations" is a food additive, which catalyzes certain biochemical reactions.

3) The definitions of each term in the specifications of food additives are as follows.

- (1) "CAS No." is an abbreviation of "Chemical Abstract Service Registry Number", and it is an international category number which can be used to replace the chemical name.
- (2) "INS No." is an abbreviation of "International Numbering System Number", and it is an international category number which can be used to replace the name of food additive and it can be a reference information of each food additive.

4) The meaning of the following terms in the Use Level of food additives are as follows.

- (1) "Dried potatoes" are powder, particle and thin layer of dried potatoes or fresh potatoes, which is cut and then heated and dried.
- (2) "Dried Fruits" is processed by drying fruits maintaining its whole shape such as dried persimmon and dried apricot, or by drying that main ingredients such as persimmon, pear, and plum to make water content become not more than 40%, and it has forms of slices, chips, etc.
- (3) "Dried Vegetables" or "Dried mushrooms" is processed by drying that main ingredients such as vegetables like spinach or mushrooms like oak mushroom to make water content become not more than 40%.
- (4) "Konjac Flour" is a product which is made from processing rhizome of elephant foot.
- (5) "Preserved fruits or vegetables" are canned or bottled products processed by drying and salting.
- (6) "Other Foods" refers to food and health functional food except for those in the standards for the use of individual food additives.
- (7) "Pickled Radish" is a product made by immersing and salting dried radish or salted radish in salt and seasoning solution and its salinity is not more than 6%.
- (8) "Mango Chutney" is a product sliced, diced, or crushed after peeling mango, which is mixed with sugar, fruit vegetables, vinegars, garlic, etc and processed by heating.
- (9) "Dried gourd shavings" is a product sliced and dried of gourd removing its cores.
- (10) "Popped Grains" is confectionary processed by compressing, heating, and swelling after adding food or food additives to ingredients such as flaked cereals and potatoes and pulses.
- (11) "Sugar Substitute Product" substitutes with sugar by directly putting in coffee or black tea
- (12) "Fish and Shellfish" refers to 2) Fish and Invertebrates in the Ingredients of Animal Origin listed in 4. Classification of Food Ingredients, Chapter 1. General Provisions, in 「Food Code」

- (13) "Dried fish and shellfish" is processed by drying fish and shellfish, which are fresh or treated by salting, boiling, steaming, or baking to make the water content become not more than 50%. It contains smoked cuttlefish or octopus, dried fish and shellfish flavored by common salt, soy bean products, sugar, and flavored dried cod.
- (14) "Frozen fish and shellfish" is product in container packing, which is made by manufacturing fish and shellfish or freezing processed fish and shellfish (excluding processed fish meat products) and cut fresh fish and shellfish (excluding a raw oyster).
- (15) "Salted fish and shellfish" is processed by putting common salt, immersing in saline solution, or wetting. Fresh fish (salinity in fish is not more than 3%), which is not for long-term preservation, is excluded.
- (16) "Processed olive products" refer to products manufactured by mixing or pickling olive with edible salts, fermented soybean or red pepper sauces and pastes, vinegars or oil or others
- (17) "Rind of natural cheese and processed cheese" is an outer layer of cheese including its sliced, shredded and crushed forms.
- (18) "Flour pastes" is made by the process that sugar, fats and oils, beef tallow, lard, powdered milk, or eggs are added to main ingredients such as wheat flour, starch, nuts, or its processed products, cocoa, chocolate, coffee, fruit juice, potatoes and pulses, legumes, or vegetables. Above foods are pasteurized and formed into a paste type.

3. General Provisions

Unless otherwise specified here in, the provisions below are to be followed.

- 1) The suitability of food additives in this notification is determined in accordance with General Provision, Standard for Manufacturing and Preparation, General Standard for Food Additives Use in Foods, Specification and Standard of the Concerned Item and General Test Methods. However, the suitability of description applies to color, odor and taste only.
- 2) Material name with parenthesis 「 」 indicates that the food additive is prescribed in standards and specification.

<MFDS's Regulation #2018-53, 2018.6.29.> [Date of entry into force 2019.7.1.]

~~3) Flavoring substances that listed 424. synthetic flavoring substances in part A. Synthetic Additives, II, 3. Specifications and Standards in the Korea Food Additives Code and Codex, FEMA (Flavor and Extract Manufacturer's Associations), or IOFI (International Organization of the Flavor Industry) can be used based on the flavoring substances of international common use. However, it cannot be used in case of safety concern. <delete>~~

- 3) In the food additives which is made from manufacture equipment as the items listed in Korea Food

Additives, the manufacture equipments of these items should be made, assembled and constituted by using appropriate mechanic equipment or parts in accordance with the 「Electrical Appliances and Consumer Products Safety Control Act」, 「Industrial Standardization Act」and the related Acts. The material of parts, which is directly contacted to final food additives, should be appropriate for the 「Standards and Specifications for Food Utensils, Containers and Packages」(MFDS's regulation).

- 4) The applicant, who wants to establish the standards and specifications of food additives in 「Food Additives Code」 or to revise use level of the food additives, may able to apply according to [Annex 1] Matters concerning Application for Establishment of Standards and Specifications of Food Additives and Revision of Use Level.
- 5) If a food additive which is not intentionally used in food is detected, it may be recognized as natural occurrence from any of the following cases: However, matters other than the following can be judged according to the provisions of [Annex 4] for the natural occurrence of food additives.
 - (1) If it is within the amount that is already recognized as natural occurrence by the Ministry of Food and Drug Safety's minister.
 - (2) If it is identified as natural occurrence from reports of domestic and foreign government and international organizations, and Journals.
- 6) Maximum Residual Limits(MRLs) for Pesticides in food additives may be permitted within the range of the Maximum Residual Limits of the materials determined in 「Food Code」. In other words, the standards of the materials are applied depending on the content of the materials, and if there are any changes of the moisture contents due to the drying process and etc., then it is applied considering the moisture content.

[Weight, Volume and Temperature]

- 7) Units of measure shall follow the metric system and the following symbols shall be used.
 - Length : m, dm, cm, mm, μm , nm
 - Volume : L, mL, μL
 - Weight : kg, g, mg, μg , ng
 - Area : dm^2 , $\text{cm}^2$1 L is 1,000 cc and 1 cc can be used interchangeably 1 mL, respectively.
- 8) Symbol "%" is used for weight percentage. However, w/v% is used for material content (g) in 100 mL of a solution and v/v% is used for material content (mL) in 100 mL of a solution. A ppm symbol is used

for parts per million in weights.

- 9) Temperature is designated with the Celsius (centigrade) scale by adding " °C " to the right of the Arabic numerals. When temperature is indicated for numerical value except standard levels such as melting point and solidifying point, etc, tolerable error should be $\pm 5^{\circ}\text{C}$ respectively.
- 10) Standard temperature is 20°C , normal temperature is $15\sim 25^{\circ}\text{C}$, room temperature is $1\sim 35^{\circ}\text{C}$, and slightly warm temperature is $30\sim 40^{\circ}\text{C}$. Warm bath is at a temperature range of $60\sim 70^{\circ}\text{C}$ and hot bath is approximately at 100°C . Unless otherwise specified, "heating in/on a water bath" means being heated at temperature of approximate 100°C or steam bath of approximate 100°C can be used as an alternative.
- 11) Unless otherwise specified, "cold place" designates a place at a temperature range of $0\sim 15^{\circ}\text{C}$.

[Tests]

- 12) A substance designated with a molecular formula, such as acetic acid ($\text{C}_2\text{H}_4\text{O}_2$), means a pure material.
- 13) Unless otherwise specified, distilled water or purified water is used for tests.
- 14) When a solvent is not specified for a "solution", it is an aqueous solution.
- 15) Unless otherwise specified, the term of "reduced pressure" means pressure is not higher than 15 mmHg.

strongly acidic : $x < 3$

slightly alkaline : $7.5 \leq x < 9$

weakly acidic : $3 \leq x < 5$

weakly alkaline : $9 \leq x < 11$

slightly acidic : $5 \leq x < 6.5$

strongly alkaline : $x \geq 11$

neutral : $6.5 \leq x < 7.5$

- 16) Unless otherwise specified, blue or red litmus paper is to be used for testing whether a material is acidic, alkaline, or neutral. pH range of acidity or alkalinity is outlined for "slightly acidic", "weakly acidic", "strongly acidic", "neutral", "slightly alkaline", "weakly alkaline", and "strongly alkaline" as follows.
- 17) Where the concentration of a solution is expressed as "(1→5)", "(1→10)", "(1→100)", etc., it means 1 g of a solid chemical or 1 mL of liquid chemical is dissolved in a solvent and is brought up to be 5 mL, 10 mL, 100 mL, respectively. For example, sodium hydroxide(1→5) is a solution where 1 g of sodium hydroxide is dissolved in water and then the total volume of the solution is brought up to be 5 mL and diluted

hydrochloric acid(2→5) is a solution where 2 mL of hydrochloric acid is diluted and is brought up to be 5 mL.

- 18) Where apparatus is used in test by number of drops, its total weight of 20 drops of distilled water at 20°C should be within a range 0.9~1.1 g.
- 19) Nestler tube in its form of flat bottom with a ground glass stopper made of clear glass, with 20 mm in inner diameter and 24 mm in outer diameter, 20 cm in length between its base and the bottom of the stopper and holding 50mL in volume is used. Height difference between scale marks of each tube should not be greater than 2 mm.
- 20) When decision is made on suitability by comparing a value acquired from a test (hereinafter referred to as an experimental value) with a value prescribed in item's specification(hereinafter referred to as a specification value), experimental value obtained one digit greater to that of a specification value is used, where the last digit of experimental value is rounded up. The expression "a ~ b" indicates that the value is not less than a and not more than b.
- 21) Atomic weights should conform to the International Periodic Table of the Elements (See Annex). Molecular weights should be calculated based on this table and up to two decimal points of the value needs to be shown by rounding up.
- 22) "Precision weighing" means to weigh specified amount of a sample using a chemical balance. For example, "precisely weighing approximately 5 g" means to take approximately 5 g of a sample and weigh it by using a chemical balance.
- 23) Unless otherwise specified, a test is to be carried out at normal temperature and observed within 30 seconds after the experiment. However, a test, which is temperature sensitive, is to be carried out at standard temperature.
- 24) For the titer of an additive, the unit specified in its specification is used.
- 25) Identification test is needed to identify an additive, where tests are done on reactions among ions, reactions among functional groups, and physical constants.
- 26) Purity test is to examine impurities in an additives, and these tests usually prescribe kinds of possible contaminants and their quantitative limits.

27) Quantitative test is to measure ingredient content or titer of an additive, where the standard limit of ingredient content or activity for the corresponding additive materials indicates the limit of the value obtained from the quantitative test. If the limit is not specified, it is set to be 100.5%.

28) An expression "white" indicates a color of white or almost white and an expression "colorless" indicates a state of being colorless or almost colorless. Unless otherwise specified, When sample is in solid form, 1 ~ 3 g of sample is placed on a watch glass on a white background for color observation. When sample is in liquid form, test sample is transferred into a test tube with an inner diameter of 1.5 cm, filled 3cm thick in the tube and observed under a white background from the top and side. An expression "should not be turbid" indicates that the turbidity is less than the high level of turbidity.

29) Expressions such as "clear", "almost clear" "very slightly turbid", "slightly turbid", and "turbid" are according to the following criteria.

- Undiluted Turbidity Standard Solution : Add water to 14.1 mL of 0.1 N hydrochloric acid so that the total volume becomes 50 mL. 1 mL of this solution contains 1 mg of Cl.
- Turbidity Standard Solution : Add water to 10 mL of undiluted turbidity standard solution so that the total volume becomes 1000 mL. 1 mL of this solution contains 0.01 mg of Cl.

(1) Clear

Add water to 0.2 mL of turbidity standard solution so that the total volume becomes 20 mL. To this solution, 1 mL of dilute nitric acid (1→3), 0.2 mL of 2 w/v% dextrin solution, and 1 mL of 2 w/v% silver nitrate solution are added. The turbidity of the resulting solution after 15 minutes is considered to be clear. Care must be taken to prevent introducing floating and foreign matters into the solution.

(2) Almost Clear

Add water to 0.5 mL of turbidity standard solution so that the total volume becomes 20 mL. To this solution, 1 mL of dilute nitric acid (1→3), 0.2 mL of 2w/v% dextrin solution, and 1 mL of 2 w/v% silver nitrate solution are added. The turbidity of the resulting solution after 15 minutes is considered to be almost clear. Care must be taken to prevent introducing floating and foreign matters into the solution.

(3) Very Slightly Turbid

Add water to 1.2 mL of turbidity standard solution so that the total volume becomes 20 mL. To this solution, 1 mL of dilute nitric acid (1→3), 0.2 mL of 2 w/v% dextrin solution, and 1 mL of 2 w/v% silver nitrate solution are added. The turbidity of the resulting solution after 15 minutes is considered to be very slightly turbid.

(4) Slightly turbid

Add water to 6 mL of turbidity standard solution so that the total volume becomes 20 mL. To this solution, 1 mL of dilute nitric acid (1→3), 0.2 mL of 2 w/v% dextrin solution, and 1 mL of 2 w/v% silver nitrate solution are added. The turbidity of the resulting solution after 15 minutes is considered to be slightly turbid.

(5) Turbid

Add water to 0.3 mL of undiluted turbidity standard solution so that the total volume becomes 20 mL. To this solution, 1 mL of dilute nitric acid (1→3), 0.2 mL of 2 w/v% dextrin solution, and 1 mL of 2 w/v% silver nitrate solution are added. The turbidity of the resulting solution after 15 minutes is considered to be turbid.

30) An expression "odorless" indicates that the sample is odorless or almost odorless. Unless otherwise specified, approximately 1 g of sample is placed on an evaporation dish for this observation.

31) Unless otherwise specified, an identification should be carried out with 2 ~ 5 mL of a solution in a test tube with an inner diameter of 1 ~ 1.5 cm.

32) Unless otherwise specified, solution characteristics are observed after stir-mixing a sample in a solvent for 30 seconds ~ 5 minutes.

33) An expression "until the weight becomes constant" upon heating or drying indicates the following. The weight difference before and after heating or drying for 1 hour is not more than 0.5 mg when a chemical balance is used. If a micro chemical balance is used, this means heat treatment is continued until the weight difference is not more than 0.01 mg. If the total weight is greater than 1 g, this means that the weight difference is not more than 0.1%.

34) When an expression "approximately" is used for a sample size of a sample, it means that 90 ~ 110% of the specified amount is to be taken.

35) Test methods, which are not prescribed in the specifications and standards, may be used if they are proven to be more precise. However, if the test result is considered to be doubtful or affecting the decision, a test should be done and a decision should be made in accordance with the methods prescribed here.

36) If the standards and specifications are not established in this regulation, or if the standards and specifications have been established but the test method is not available, the test method could be followed by CAC(Codex Alimentarius Commission), FCC(Food Chemicals Codex), ASTM(American

Society for Testing and Materials), And AOAC(Association of Official Analytical Chemists) and etc. If the test method is not available in above test methods, it can be tested according to the test methods specified in other laws and regulations, the internationally accepted official test methods, the certified major foreign test methods, or the test methods approved by the Ministry of Food and Drug Safety.

37) Test of food additive which conform to subject of labeling in accordance with article 3 of 「Labeling Standard for Genetically Modified Foods」 follow the test method for Genetically Modified food of 「Standard and Specification of Food」.

38) Identification test of enzyme preparation tested by Activity assay of individual food additive. However, if it is impossible to test as directed identification method, a change of substrate, dilution ratio of samples, buffer solution, and reaction temperature should only be available to the case that scientific justification is confirmed.

[Container]

39) "Hermetic Container" is a container that protects the contents by preventing penetration of air or other gases during handling or storage.

40) "Light-resistant container" is a container that does not transmit light or protects the contents from deterioration due to light. If a container does not shield light, it can be wrapped appropriately and used as a light-shielding container.

II. Food Additives and Mixed Preparations

1. Standards for Manufacturing and Preparation

1) Standards applying generally to all food additives

- (1) Food additives should be treated like food materials and be suitable to the individual specifications.
- (2) Unless it is absolutely indispensable, insoluble minerals such as acidic white clay, china clay, bentonite, talc, sand, diatomite, magnesium carbonate, and their similar minerals should not be used in the manufacturing of additives.

2) Mixed Preparations

- (1) Additives, which are used to prepare mixed preparations, must be one listed in the Food Additives Codes and be suitable to the individual specifications. A substance (except for synthetic additives) recognized as a food additive on the status of product specific individual standard and specification with time-limit in use can be a component of additive mix preparation.
- (2) When additives mix preparations are prepared, the purpose of the preparation should be appropriate for use in foods, and the composition of preparation should not be to alter chemically the original components.
- (3) Diluent, which are used to prepare mixed dilution or diluted mixed preparations, must be one of starch (excluding starches modified and classified as food additives), wheat flour, glucose, sugar and others recognized generally as food ingredients.
- (4) When preparing mixed preparations, additives such as antioxidant, preservatives, emulsifiers, stabilizers, or dissolving agents may be used if it is indispensable to maintain the stability in quality and to form necessary shape. The amount of addition must be kept at a minimum level, where the required technical effects can be achieved.
- ~~(5) When manufacturing or processing alkali Additives for Noodles Preparations, each shall be a mixture of one or more types of sodium carbonate, potassium carbonate, sodium hydrogen carbonate, sodium phosphate or potassium salt, appropriate to its specifications, or their solutions, or diluted with wheat flour.~~

3) Genetically Modified Organisms Food Additives

Food additives prepared by using microorganism acquired by genetically modified organisms technology should be approved on 「Regulation for Examination of Genetically Modified Organisms Safety Evaluation」(MFDS Notification) under Article 18 of 「Food Sanitation Law」and suitable to specification and standards.

4) Materials of Food Additives and Extraction Solvents

- (1) Raw materials such as right inner skin used in the production of gelatin should not be subjected to a hardening process such as chrome treatment.
- (2) Raw materials such as chitin, chitosan, glucosamine, carrageenan, alginic acid and cochineal extract pigment(including carmine) should be handled hygienically during collection, storage and transportation.
- (3) Extraction solvents used in food additives made from natural animals, plants, minerals, etc. are water, spirits, and solvents which are noted in the individual standards of this regulation, or Trichloroethylene and Methylene chloride which are in compliance with the individual standard of [Table 3]. However, the solvents used(except water and spirits) should be removed prior to the final product completion.
- (4) 1-hydroxyethylidene-1,1-diphosphoric acid should be used only for manufacturing Peroxyacetic acid, and specifications shall comply with the specifications of [Annex 3].

2. General Use Level

- 1) The usage of a food additive should be limited to a minimum amount that is required to achieve its physical, nutritive, and other technical effects.
- 2) Additives should not be used for purposes to conceal faulty raw materials or unsanitary processes during food manufacturing processes.
- 3) Nutritional enhancers added to food should be used to maintain or improve the nutritional quality of the food, and should not cause excessive intake or unbalanced intake of nutrients.
- 4) The food additives with other functional class which are not noted on the major functional class part of this regulation can be used if the technical effect has been proved internationally and validity of the use is recognized.
- 5) Article 6 of the 「Food Hygiene Act」 and the standards and specifications set forth herein may not be applied to those additives when they are used, in the course of manufacturing, processing, in foods for exports according to the 「Rules and Regulations for Overseas Trade」, or when they are used in foods to be consumed on an airplane or a ship traveling overseas with the permission from the Custom's Superintendent in accordance with article 143 of the 「Customs Regulations」, or when they are used in foods for the patient with inborn errors in metabolism.

3. Preservation and Distribution Standards

- 1) Food additives should be hygienically stored and sold, and they should not be located in places where storage and sale places are unclear. Also, it is necessary to thoroughly manage the cleaning and insect control.
- 2) The place of handling of food additives should be protected from rain, snow, etc., and should not be stored together with chemicals such as chemical agents, pesticides, toxic substances, etc. which are harmful to human body.
- 3) Care should be taken not to contaminate foreign material, and separate from other food additives which may affect quality such as flavor of food additives.
- 4) Food additives which may cause moisture absorption should be careful not to absorb moisture.
- 5) During the transportation and packaging of food additives, care should be taken not to damage the containers and packaging, and they should be avoided physical shock as much as possible.
- 6) Unless otherwise stipulated, it should be stored and distributed in a cool place so that physical deformation or rust of containers and packaging, containing food additives, should not occur.

4. Specification of Food Additives

A. Food Additives

Acesulfame Potassium

Acesulfame K

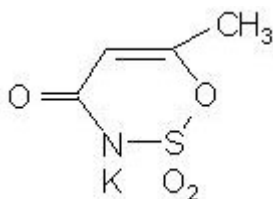

Chemical Formula: $C_4H_4KNO_4S$

Molecular Weight: 201.24

INS No.: 950

Synonyms: Acesulfame K; Potassium salt of 3,4-dihydro-6-methyl-1,2,3-oxathiazin-4-one-2,2-dioxide

CAS No.: 55589-62-3

Compositional Specifications of Acesulfame Potassium

Content Acesulfame Potassium, when calculated on the dried basis, should contain within a range of 99.0 ~ 101.0% of acesulfame potassium ($C_4H_4KNO_4S$).

Description Acesulfame Potassium is scentless white crystalline powder with strong sweet taste.

Identification (1) A solution of 10 mg of Acesulfame Potassium in 1,000 mL of water shows a maximum absorption band in a wavelength range of 225~229 nm.

(2) Acesulfame Potassium responds to test of potassium salts in Identification.

(3) 0.2 g of Acesulfame Potassium is dissolved in 2 mL of acetic acid (30→100) and 2 mL of water. Upon adding a few drops of sodium cobalt nitrite solution, yellow precipitates are formed.

Purity (1) Fluoride : Fluoride : 1 g of Acesulfame Potassium is precisely weighed and is tested by purity (8) for 「Calcium Citrate」, its content should not be more than 3 ppm.

(2) Lead : When 5.0 g of Acesulfame Potassium is tested by Atomic Absorption Spectrophotometry or Inductively Coupled Plasma Emission Spectroscopy, its content should not be more than 1.0 ppm.

(3) Other UV absorbing matters : 1 g of Acesulfame Potassium is precisely weighed and dissolved in water so that the total volume to make 100 mL (Test Solution). 20 μ l of this Test Solution is injected into a liquid chromatography using the following operation conditions. When other peaks appear

within three times of the retention time of the main peak, the Test Solution is further diluted with water (50,000 times). With 20 μ l of this diluted solution, the same test is repeated. The sum of peak areas (for the Test Solution) of all the peaks (excluding the main peak) that appear within three times of the retention time of the main peak should not be bigger than the area of the main peak measured with the diluted solution (50,000 times). (not more than 20 ppm as acesulfame potassium).

Operation Conditions

-Detector : UV 227 nm

-Column : 3~5 μ m ODS(4.6 mm \times 250 mm) or its equivalent

-Mobile Phase : A mixture of acetonitrile : 0.01 mol/l tetrabutyl ammonium hydrogen sulfate (40 : 60)

-Flow Rate : 1 mL/min

10 mg of each material is weighed and dissolved in water (total volume 1,000 mL). 20 μ l of this solution is injected into liquid chromatography following the above procedure. 20 μ l of this solution is injected into liquid chromatography following the above procedure. The column should be able to separate Acesulfame Potassium and 「ethyl p-hydroxybenzoate」.

Loss on Drying When Acesulfame Potassium is dried for 2 hours at 105°C, the loss should not be more than 1.0%.

Assay Dissolve about 0.15 g of Acesulfame Potassium, previously dried and accurately weighed in 50 mL of acetic acid. This solution is titrated with 0.1 N perchloric acid solution (indicator : 1 mL of crystal violet-glacial acetic acid solution). At the end point, the bluish green color of the solution persists for 30 seconds or longer. Separately, a blank experiment is carried out following the same procedure for correction.

1 mL of 0.1 N perchloric acid solution = 20.12 mg $C_4H_4KNO_4S$

Acetic Acid

Chemical Formula: $C_2H_4O_2$

Molecular Weight: 60.05

Compositional Specifications of Acetic Acid

Content Acetic Acid should contain within a range of 29.0 ~ 31.0% of acetic acid ($C_2H_4O_2 = 60.05$).

Description Acetic Acid is a colorless and clear liquid having a characteristic pungent odor and an acid taste.

Identification (1) Acetic Acid is strongly acidic.

(2) Acetic Acid responds to the test for Acetate in Identification.

Purity (1) Arsenic : 0.25 g of Acetic Acid transfer into a platinum, quartz, or porcelain crucible. 10 mL solution of magnesium nitrate in ethyl alcohol (1→50) is added to the crucible and then alcohol is ignited. It is then reduced to ash by heating at 450~550°C. If carbonaceous substance persists, it is wetted with minute amount of nitric acid, which is further heat-treated at 450~550°C. After cooling, 3 mL of hydrochloric acid is added to the residue, which is then dissolved by heating in a water bath. When test by Arsenic Limit Test is carried out with this test solution, it should not be more than 4.0 ppm.

(2) Heavy Metals : 3 mL of Acetic Acid is tested by Heavy Metal Limit Test. Its content should not be more than 10 ppm. In this case, 3 mL of lead standard solution is used for a color standard. Lead : When 5.0 g of Acetic Acid is tested by Atomic Absorption Spectrophotometry or Inductively Coupled Plasma Emission Spectroscopy, its content should not be more than 0.5 ppm.

(3) Readily Oxidizable Substances : To 20 mL of Acetic Acid, add 0.3 mL of 0.1 N potassium permanganate. The color of the solution does not disappear within 30 minutes.

(4) Residue on Evaporation : Proceed as directed under Purity (5) in [Glacial Acetic Acid].

Assay Accurately weigh about 3 g of Acetic Acid, add 15 mL of water. Titrate with 1 N sodium hydroxide (indicator : 2 drops of phenolphthalein solution).

1 mL of 1 N sodium hydroxide solution = 60.05 mg of $C_2H_4O_2$

α -Acetolactate decarboxylase

Definition It is an enzyme obtained from a culture of *Bacillus subtilis* that contains the gene for α -acetolactate decarboxylase from *Bacillus brevis*. Dilutant or stabilizer can be added for the purpose of activity adjustment and quality preservation.

Compositional Specifications of α -acetolactate decarboxylase

Description It is white ~ dark brown powder, particle, paste or colorless ~ dark brown liquid.

Identification When α -acetolactate decarboxylase is proceeded as directed under Activity Test, it should have the activity as α -acetolactate decarboxylase.

Purity (1) Arsenic : It should be no more than 4.0 ppm tested by Arsenic Limit Test.

(2) Lead : When 5.0 g of α -acetolactate decarboxylase is tested by Atomic Absorption Spectrophotometry or Inductively Coupled Plasma Emission Spectroscopy, its content should not be more than 5.0 ppm.

(3) Coliform Group : α -acetolactate decarboxylase proceed as directed under Microbiological Methods for Coliform Group in General Testing Methods「Standards and Specification for Foods」. It should not be more than 30 per 1 g.

(4) Salmonella : α -acetolactate decarboxylase is tested by Microbiological Methods for Salmonella in General Testing Methods 「Standards and Specification for Foods」. It should be negative (-).

(5) E. coli : α -acetolactate decarboxylase proceed as directed under Microbiological Methods for E. coli in General Testing Methods「Standards and Specification for Foods」. It should be negative (-).

Activity Test (Activity)

- Analysis Principle : Activity test is based on measuring the absorbance of the mixture in the following manner: react the enzyme with α -acetolactate to produce acetoin, react the resultant acetoin with mixture of 1-naphthol and creatine, measure absorbance.
- Preparation of test Solution : Dissolve the sample in the mixture of MES/Brij 35/NaCl solution and prepare final diluted solution containing 0.025 ~ 0.075 ADU per 1 mL.
- Test Procedure : Warm the enzyme solutions, MES buffer, and the substrate in water bath at 30°C for approximately 10minutes. Enzyme blank(B1). Pipette 0.2 mL of enzyme solution and 0.2 mL of MES buffer into a test tube. Mix, and immediately place the test tube back into the water bath at 30°C for 20min. Sample value(H1). Pipette 0.2 mL of enzyme solution and 0.2 mL of substrate into a test tube. Mix, and immediately place the test tube into the water bath at 30°C for 20min. Buffer blank(B2). Pipette 0.2 mL of MES buffer and 0.2 mL of MES/Brij 35/NaCl solution into a test tube. Mix, and immediately place the test tube into the water bath at 30°C for 20min. Buffer value(H2). Pipette 0.2 mL of MES/Brij 35/NaCl solution and 0.2 mL of substrate into a test tube. Mix, and immediately place the test tube into the water bath at 30°C for 20min. Exactly 20 min after mixing of each of solution B1, H1, B2, and H2, remove from water bath, add 4.6 mL of colour reagent, mix and leave at room temperature for exactly 40 min. At the end of this 40 min period measure the absorbance of the solution at 522 nm on a

spectrophotometer or equivalent.

- Preparation of standard curve : Dissolve 0.1 g of acetoin in water in a 100-mL volumetric flask. Make to volume with water. Dilute 1, 2, 4, 6, and 8 mL of stock acetoin solution to volume with water in 100 mL volumetric flasks. Pipette 0.4 mL of the acetoin standard solutions into test tubes. Add 4.6 mL of colour reagent to each tube, mix, and let the test tube stand at room temperature for exactly 40 min. At the end of this 40 min period, measure absorbance at 522 nm. Plot optical density values at 522 nm for the acetoin standards against acetoin concentration($\mu\text{g/mL}$) of standard and generate a standard curve. Activity of an enzyme is calculated by the following equation.

$$\text{Activity of an enzyme(ADU/g)} = \frac{\Delta A \times F}{88.1} \times 5.0 \times \frac{1}{20} \times \frac{1}{0.2} \times \frac{1}{w}$$

ΔA : $(H_1 - B_1) - (H_2 - B_2)$

F : The concentration($\mu\text{g/mL}$) of acetoin against one of absorbance obtained from standard curve

88.1 : Molecular weight of acetoin

5.0 : The volume of final enzyme solution(mL)

20 : reaction time(min)

0.2 : Taken volume of enzyme solution(mL)

W : Weight of enzyme in 1 mL of enzyme solution(g)

Definition of activity : One α -acetolactate decarboxylase is the amount of enzyme which, by decarboxylation of α -acetolactate produces 1 μmol of acetoin per min under above the test reaction conditions.

Solutions

- MES buffer (0.05 M, pH 6.0) : Dissolve 9.76 g of MES2-(N-morpholino) ethanesulphonic acid in approximately 900 mL of water. Adjust pH to 6.0 with 1N NaOH. Transfer to a 1,000 mL volumetric flask and make to volume with water. This solution may be kept for two weeks at room temperature.
- Brij 35 solution, 15% w/v : Dissolve 15.0 g of Brij 35(polyoxyethylene lauryl ether) in approximately 70 mL of water, heating to 60°C to aid dissolution. Cool the solution, transfer to a 100 mL volumetric flask and make to volume with water. This solution should be stored in a refrigerator, and can be kept for up to two months.
- MES/Brij 35/NaCl solution : Dissolve 48.8 g of MES and 175.32 g of NaCl in approximately 4,500 mL

of water. Add 17 mL of 15% Brij 35 solution. Adjust pH to 6.0 with 1 N NaOH. Transfer to a 5,000 mL volumetric flask and make to volume with water. This solution may be kept for two weeks at room temperature.

- α -Acetolactate substrate : Pipette 100 μl of ethyl-2-acetoxy-2-methylacetolactate into a 50 mL volumetric flask. Add 6.0 mL of 0.5 N NaOH to the flask and stir for 20 min. Add MES buffer to bring the volume to approximately 40 mL. Adjust pH to 6.0 with 0.5 N HCl. Make to volume with MES buffer. This substrate should be made just before use.
- Colour reagent : Dissolve 5.0 g of 1-naphthol and 0.5 g of creatine in 1 N NaOH, make to volume with 1 N NaOH in a 500 mL volumetric flask. This colour reagent should be made fresh just before use

Storage Standards of α -acetolactate decarboxylase

α -acetolactate decarboxylase should be stored in a hermetic container in a cold dark place.

Acetone



Chemical Formula: $\text{C}_3\text{H}_6\text{O}$

Molecular Weight: 58.08

Synonyms: 2-Propanone; Dimethyl ketone

CAS No.: 67-64-1

Compositional Specifications of Acetone

Content Acetone should contain within a range of 99.5 ~ 100.5% of Acetone ($\text{C}_3\text{H}_6\text{O}$)

Description Acetone is colorless, transparent, volatile liquid with characteristic odor.

Identification 0.1 mL of acetone is mixed with 10 mL of water, 5 mL of sodium hydroxide is added, heated, and 5 mL of iodine solution, then yellow precipitate of iodoform is generated.

Purity (1) Solubility : When 38 mL of Acetone (corresponds to about 30 g) is mixed with boiled and cooled water (50:50), this solution should be clear at least for 30 minutes. the same amount of water after 1 hour.

(2) Acid Value (as acetic acid) : 38 mL of Acetone is mixed with boiled and cooled water (50:50), titrated with 0.1N sodium hydroxide solution, then the consumption should not be more than 0.1 mL. (Indicator : phenolphthalein solution)

(3) Alkali Value (as ammonia) : 1 drop of Methyl red solution is added to 25 mL of water and 0.1 N sulfuric acid is added until red color develops. 23 mL of Acetone (corresponds to about 18g) is added, titrated with 0.1N sulfuric acid, the consumption should not be more than 0.1 mL.

(4) Aldehydes (as formaldehyde) : 2.5 mL of Acetone (corresponds to about 2g) is dissolved in 7.5 mL of water, test solution. 40 μg of formaldehyde is dissolved in 10 mL of water, standard solution. 0.15 mL of 5% 5,5-dimethyl-1,3-cyclohexanedione alcohol solution is added to test solution and standard solution respectively, and evaporated in a water bath until acetone is volatilized. Water is added to make 10 mL, vigorously stirred in an ice bath, rapidly cooled, the turbidity of test solution should not be deeper than turbidity of standard solution. (not more than 0.002%).

(5) Matters that reduce permanganates : 10 mL of Acetone is transferred into a cylinder with a stopper. After adding 0.05 mL of 0.1 N potassium permanganate solution, it is set aside for 15 minutes. Pale red color should not disappear completely.

(6) Lead : When 5.0 g of Acetone is tested by Atomic Absorption Spectrophotometry or Inductively Coupled Plasma Emission Spectroscopy, its content should not be more than 1.0 ppm.

(7) Methyl alcohol : To 1 mL each of test solution, where water is added to 10 mL of acetone to make 100 mL, and methyl alcohol standard solution (40 $\mu\text{g}/\text{mL}$ water), 0.2 mL of 10% phosphate and 0.25 mL of potassium permanganate (1 \rightarrow 20) are added, and set aside for 15 minutes. 0.3 mL of sodium

bisulfite(1→10) is added and shaken until it becomes colorless. 5 mL of 80% sulfuric acid cooled in ice is gradually added while keeping cold. 0.1 mL of chromotropic acid(1→100) is added, immersed in a water bath for 20 minutes, then the purple color in test solution should not be deeper than that of standard solution (not more than 0.05%).

(8) Phenols : 3 mL of acetone is evaporated to dryness at 60°C, 3 drops of sulfuric acid solution of sodium nitrite(0.1→5) are added, and set aside for 3 minutes. When 3 mL of 2N sodium hydroxide is carefully added, it should not be colored.

(9) Distillation test : When acetone is tested for boiling point and amount of distillate, 95%(v/v) or more should be extracted at 55.1~57.1°C.

(10) Residue on Evaporation : 125 mL (approximately 100 g) of acetone is dried in a water bath and is further dried for 30 minutes at 105°C. The weight of the residue should not be more than 10 ppm.

(11) Refractive Index : Refractive Index n_D^{20} of Acetone should be within a range of 1.358~1.360.

(12) Specific Gravity : Specific gravity of Acetone should be within a range of 0.790~0.793.

Water Content Water content of Acetone is determined by water determination (Karl-Fischer Method) and should not be more than 0.5%.

Assay The content of Acetone is tested by determination of specific gravity. It should not be more than 0.7930 as specific gravity.

Acetophenone



Chemical Formula: C_8H_8O

Molecular Weight: 120.15

Synonyms: Methyl phenyl ketone; Acetyl benzene

CAS No.: 98-86-2

Compositional Specifications of Acetophenone

Content Acetophenone should contain not less than 98.0% of Acetophenone (C_8H_8O).

Description Acetophenone occurs as white crystalline lumps or is a colorless or slightly yellowish and transparent liquid. It has a characteristic odor.

Identification (1) To 1 drop of Acetophenone, add 1 mL of water, shake well, add 2 drops of sodium nitroprusside solution, add 2 drops of sodium hydroxide solution (3→10), and shake. A dark red color develops. Add 5 drops of diluted acetic acid. A deep blue color develops.

(2) 5 mL of a solution, 5 g of semicarbazide hydrochloric acid salt and 5 g of potassium acetate are dissolved in 15 mL of water, is added to 1 g of Acetophenone. When 5 mL of alcohol is added to this solution, white crystals are formed after mixing and settling. The crystals are recrystallized in dilute alcohol. The melting point is approximately 198°C.

Purity (1) Solidifying Point : Solidifying Point should not be less than 19°C.

(2) Refractive Index : Refractive Index n_D^{20} of Acetophenone should be within a range of 1.533~1.535.

(3) Clarity and Color of Solution : When 1 mL of Acetophenone is dissolved in 5 mL of 50% alcohol, the solution should be clear.

(4) Chlorides : When Acetophenone is tested by Copper Mesh Test Method in Halogenated Compounds for Flavoring, it should be appropriate.

Assay Accurately weigh about 1 g of Acetophenone, and proceed as directed under Method 2 in Aldehyde and Ketone Content in Flavoring Substances Tests. In the procedure, heat the mixture for 1 hour.

0.5 N hydrochloric acid 1 mL = 60.08 mg of C_8H_8O

Acid Clay

Definition Acid Clay is obtained by purifying clay minerals such as monmorillonite. Major components are hydrated aluminum silicate.

Compositional Specifications of Acid Clay

Description Acid Clay is gray ~ pale yellow fine powder.

Identification (1) 1 g of Acid Clay is placed in a porcelain crucible, where 10 mL of water and 5 mL of sulfuric acid are added. It is then evaporated to dryness by heating and cooled. 20 mL of water is added to the crucible, which is then boiled again for 2 ~ 3 minutes. The mixture is filtered. The color of the residue is gray.

(2) The filtrate in (1) is showed the reaction of aluminum salts in Identification.

Purity (1) pH : 1 g of Acid Clay is suspended in 50 mL of water, which is then filtered. pH of the filtrate should be 3.0 ~ 5.0.

(2) Arsenic : It should be no more than 4.0 ppm tested by Arsenic Limit Test.

(3) Lead : 3.75 g of Acid Clay, previously dried, is placed in a 250 mL beaker, where 100 mL of diluted hydrochloric acid (1→25) is added and mixed well. It is then boiled covered with watch glass for 15 minutes. It is cooled and allowed to stand for settling the insoluble substances. It is then filtered through a filter paper at a high flow rate. The residues on the filter paper are washed four times with 25 mL each of hot water. Washing water is added to the previous filtrate, which is concentrated to approximately 20 mL by heating gently. If precipitates are formed, 2 ~ 3 drops of nitric acid are added and boiled again. After cooling to room temperature, the concentrated filtrate is filtered through a filter paper into a 50 mL beaker at a high flow rate. The beaker and the residue on the filter paper are washed with water and the washing water is added to the filtrate. The total volume is brought up to 50 mL with water, Test Solution. When the test solution is tested by Atomic Absorption Spectrophotometry or Inductively Coupled Plasma Emission Spectroscopy, its content should not be more than 40.0 ppm.

Loss on Drying When 2 g of Acid Clay is dried at 105°C until the weight becomes constant, the weight loss should not be more than 10.0%.

Active Carbon

Synonyms: Carbon, activated

CAS No.: 7440-44-0

Definition This is a obtained from the substance containing carbon, which include sawdust, wood pieces, fibers of palm tree barks, lignite, or petroleum, is carbonized and activated to prepare active carbon.

Compositional Specifications of Active Carbon

Description Active Carbon is scentless and tasteless black powder or solid.

Identification (1) 0.5 g of Active Carbon(as is for powder, ground for solid) is placed in a test tube. It is heated with a direct flam in a flowing air. It doesn't catch fire but does combust. Combustion gas is passed through an aqueous solution of potassium hydroxide, which turns the solution white and turbid.

(2) 0.1 g of Active Carbon (as is for powder, ground for solid) is well mixed with 10 mL of diluted methylene blue solution and 2 drops of hydrochloric acid by shaking. When the mixture is filtered through a quantitative filter paper (5 type C), the filtrate should be colorless.

Purity Preparation of Test Solution : Active Carbon (as is for powder, ground for solid) is dried for 3 hours at 110~120°C. 180 mL of water containing 0.1 mL of diluted nitric acid (1→100) is added to 4 g of the dried material, which is weakly boiled for 10 minutes. Cool the solution, and dilute the resulting solution to 200 mL with water and filtered through a quantitative filter paper (5 type C). Discard approximately initial 30 mL of the filtrate. Collected filtrate (Test Solution) is tested as follows.

(1) Chloride : 1 mL of Test Solution is tested for Chloride. Test for chloride content should not be more than correspond to 0.3 mL of 0.01 N hydrochloric acid.

(2) Sulfate : 2.5 mL of Test Solution is tested for sulfates. Test for sulfate content should not be more than correspond to 0.5 mL of 0.01 N sulfuric acid.

(3) Arsenic : It should be no more than 4.0 ppm tested by Arsenic Limit Test.

(4) Lead : When test Solution is tested by Atomic Absorption Spectrophotometry or Inductively Coupled Plasma Emission Spectroscopy, its content should not be more than 5.0 ppm.

(5) Zinc : When test Solution is tested by Atomic Absorption Spectrophotometry or Inductively Coupled Plasma Emission Spectroscopy, its content should not be more than 25 ppm.

(6) Cyanogen compound : Weight 5g of Active Carbon is precisely into a flask. Add 50 mL of water and 2 g of tartaric acid, and attach distilling apparatus. 2 mL of 1N sodium hydroxide solution and 10 mL of water are added in the collector, and the end of condenser is immersed in this solution. It is distilled while being cooled with ice and collected in 25 mL of distillate. Water is added to distillate to make 50 mL and 1 mL of iron sulphate solution (1→20) is added to 25 mL of this solution. Heat until boiled, and then cool, filter. When adding 1 mL of hydrochloric acid and 0.5 mL of diluted iron chloride solution to this solution, blue color should not be showed.

(7) Aromatic hydrocarbon : Add 12 mL of cyclohexane to 1 g of Active Carbon , and attach a reflux

condenser. Heat for 2 hours in a water bath and cool to use test solution. Transfer Test solution into a nestler tube. When this solution is observed with irradiating ultraviolet rays, solution should not be thick than the color of the solution, which is obtained by processing 12 mL of solution made by dissolving 0.1 mg of quinine sulfate in 1,000 mL of 0.1N sulfuric acid in the same manner as test solution.

5'-Adenylic acid

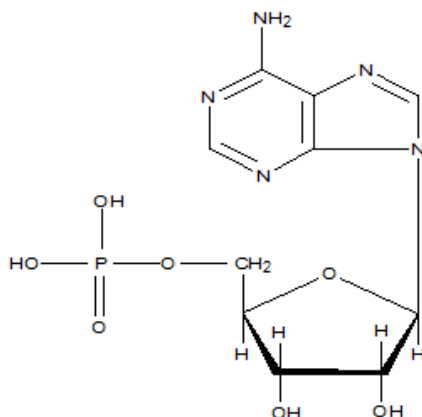

Chemical Formula: $C_{10}H_{14}N_5O_7P$

Molecular Weight: 347.22

CAS No.: 61-19-8

Definition 5'-Adenylic acid is obtained by hydrolyzing (with enzyme) the hexane extracted from yeast (*Candida utilis*, *Kluyveromyces fragilis*) with hot water under the presence of salts..

Compositional Specifications of 5'-Adenylic acid

Content If 5'-Adenylic acid is converted to a dehydrated form, it should contain 98.0~102.0% 5'-adenylic acid ($C_{10}H_{14}N_5O_7P$).

Description 5'-Adenylic acid is white crystalline powder.

Identification (1) 0.2 g of 5'-Adenylic acid is precisely weighted and dissolved in 10 mL of 0.1 N sodium hydroxide solution, which is diluted to 200 mL with water. 2 mL of this solution is diluted to 100 mL with 0.01 N hydrochloric acid. The resulting solution has a maximum absorption band near 257 nm.

(2) 1 mL of hydrochloric acid and 1 mL of bromine solution are added to 3 mL aqueous solution of 5'-Adenylic acid (3→10,000), which is then heated for 30 minutes. Bromine is removed in a flowing air. 0.2 mL of orcin solution in alcohol (1→10) is added to this solution. To the resulting solution, 3 mL of ammonium ferric sulfate · hydrochloric acid solution (1→1,000) is added and heated for 20 minutes in a water bath. The final solution turns green.

(3) 0.25 g of 5'-Adenylic acid is precisely weighted and dissolved in 1 mL of sodium hydroxide solution (1→25), which is diluted to 5 mL of water. When 2 mL of magnesia solution is added to this solution, precipitates are not observed. To resulting solution, 7 mL of nitric acid is added and boiled for 10 minutes in a water bath. When the resulting solution is neutralized with sodium hydroxide solution (1→25), it shows the reaction of (B) Phosphate Salts in Identification.

Purity (1) Arsenic : It should be no more than 4.0 ppm tested by Arsenic Limit Test.

(2) Lead : When 5.0 g of 5'-Adenylic acid is tested by Atomic Absorption Spectrophotometry or

Inductively Coupled Plasma Emission Spectroscopy, its content should not be more than 10.0 ppm.

(3) Solution: 0.5g of 5'-Cytidylic acid is weighted and dissolved in 2mL of sodium hydroxide solution, which is diluted to 10mL with water. the solution is nearly colorless and clear.

(4) Other nucleic acid hydrolysates: 0.1g of 5'-Cytidylic acid is weighted and dissolved in 0.5mL of sodium hydroxide solution, which is diluted to 20mL with water. When 1 $\mu\ell$ of the test solution is tested with the mixed solution of acetone-ammonia solution-n-propanol (2:5:6) by Thin Layer Chromatography, it should not show spots except for one original spot. Supporting material of thin layer plate must be used as dried one with silicagel(added fluorescent agent) for 1 hour at 110°C. When the solvent is developed up to 10cm from the base line, stop the developing. After drying with wind, the plates are observed under a UV light (about 250nm wavelength). The control solution is not used.

(5) Absorption Ratio : 20 mg of 5'-Adenylic acid is precisely weighted and dissolved in hydrochloric acid (1 \rightarrow 1,000) (total volume = 1,000 mL). Absorptions A_1 , A_2 , and A_3 are measured at 250 nm, 260 nm, and 280 nm are measured. A_1/A_2 and A_3/A_2 should be 0.82~0.88 and 0.19~0.23.

Loss on Drying When 5'-Adenylic acid is dried for 4 hours at 120°C, the weight loss should not be more than 6.0%.

Assay 0.2 g of 5'-Adenylic acid is precisely weighted and dissolved in 10 mL of 0.1 N sodium hydroxide solution , which is diluted to 200 mL with water. 2 mL of this solution is further diluted to 200 mL with 0.01 N hydrochloric acid (Test Solution). Absorption A of Test Solution is measured at 257 nm with 1cm path length using 0.01 N hydrochloric acid as a reference. The content of 5'-adenylic acid is obtained by the following equation.

$$\text{Content(\%)} = \frac{0.2}{\text{weight of the sample(g)}} \times \frac{229.9 \times A}{100 - \text{loss on drying(\%)}} \times 100$$

Adipic Acid

Chemical Formula: $C_6H_{10}O_4$

Molecular Weight: 146.14

INS No.: 355

Synonyms: Hexanedioic acid

CAS No.: 124-04-9

Compositional Specifications of Adipic Acid

Content Adipic Acid should contain within a range of 99.6 ~ 101.0% of adipic acid ($C_6H_{10}O_4$).

Description Adipic Acid occurs as white crystals or crystalline powder. It is readily soluble in alcohol but hardly soluble in water.

Purity (1) Arsenic : It should be no more than 4.0 ppm tested by Arsenic Limit Test.

(2) Lead : When 5.0 g of Adipic Acid is tested by Atomic Absorption Spectrophotometry or Inductively Coupled Plasma Emission Spectroscopy, its content should not be more than 2.0 ppm.

(3) Mercury : When Adipic Acid is tested by Mercury Limit Test, its content should not be more than 1.0 ppm.

(4) Melting Point : Melting point of Adipic Acid should be within a range of 151.5 ~ 154.0°C.

Water Content Water content of Adipic Acid as determined by water content determination method (Karl-Fischer Method) should not be more than 0.2%.

Assay 1.5 g of Adipic Acid, accurately weighed, is transferred into a Erlene Meyer flask with a stopper, where 75 mL of freshly boiled and cooled water is added. It is then titrated with 0.5 N sodium hydroxide solution (indicator : 2 ~ 3 drops of phenolphthalein solution).

1 mL of 0.5 N sodium hydroxide = 36.54 mg of $C_6H_{10}O_4$

DL-Alanine

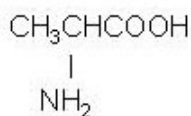

Chemical Formula: C₃H₇NO₂

Molecular Weight: 89.09

INS No.: 639

Synonyms: DL-2-Aminopropanoic acid

CAS No.: 302-72-7

Compositional Specifications of DL-Alanine

Content DL-Alanine, when calculated on the dried basis, should contain within a range of 98.5 ~ 102.0% of DL-alanine (C₃H₇NO₂).

Description DL-Alanine occurs as a colorless to white crystalline powder having a sweet taste.

Identification (1) Dissolve 0.2 g of DL-Alanine in 10 mL of diluted sulfuric acid. Add 0.1 g of potassium permanganate, and boil. An odor of acetaldehyde is evolved.

(2) To 5 mL of DL-Alanine solution (1→1,000), add 1 mL of ninhydrin solution. and heat for 3 minutes. A purple color develops.

Purity (1) Clarity and Color of Solution : 1.0 g of DL-Alanine is dissolved in 10 mL of water. It is colorless and clear.

(2) pH : pH of DL-Alanine solution (1→20) should be within a range of 5.5 ~ 7.0

(3) Arsenic : It should be no more than 4.0 ppm tested by Arsenic Limit Test.

(4) Lead : When 5.0 g of DL-Alanine is tested by Atomic Absorption Spectrophotometry or Inductively Coupled Plasma Emission Spectroscopy, its content should not be more than 5.0 ppm.

Loss on Drying When DL-Alanine is dried for 3 hours at 105°C, the weight loss should not be more than 0.3%.

Residue on Ignition Residue on Ignition of DL-Alanine should not be more than 0.2%.

Assay Accurately weigh about 0.2 g of DL-Alanine, dissolve it in 3 mL of formic acid and proceed as directed under Assay in 「Glycine」.

1 mL of 0.1 N perchloric acid = 8.909 mg of C₃H₇NO₂

L-Alanine

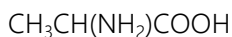

Chemical Formula: $\text{C}_3\text{H}_7\text{NO}_2$

Molecular Weight: 89.09

Synonyms: L-2-Aminopropanoic acid

CAS No.: 56-41-7

Compositional Specifications of L-Alanine

Content If L-Alanine, when calculated on the dried basis, should contain 98.5~101.5% L-alanine ($\text{C}_3\text{H}_7\text{NO}_2$).

Description L-Alanine is white scentless sweet crystalline powder.

Identification (1) 1 mL of ninhydrine solution (0.2→100) is added to 5 mL of L-Alanine solution (1→1,000). Upon heating for 3 minutes in a water bath, this solution becomes violet.

(2) 0.2 g of L-Alanine is dissolved in 10 mL of water and 0.1 g of potassium permanganate is added. Upon boiling, smell of acetaldehyde is generated.

Purity (1) Specific Rotation : 10 g of L-Alanine, previously dried, is dissolved in 6 N hydrochloric acid, where the total volume of the solutions 100 mL. Optical density of this solution should be within a range of $[\alpha]_D^{20} = +13.5 \sim +15.5^\circ$

(2) Lead : When 5.0 g of L-Alanine is tested by Atomic Absorption Spectrophotometry or Inductively Coupled Plasma Emission Spectroscopy, its content should not be more than 5.0 ppm.

(3) Arsenic : It should be no more than 4.0 ppm tested by Arsenic Limit Test.

(4) Chloride: When 0.07 g of L-Alanine is tested by Chloride Limit Test, its content should not be more than the amount that corresponds to 0.2 mL of 0.01 N hydrochloric acid.(Not be more than 0.1%)

Loss on Drying When L-Alanine is dried for 3 hours at 105°C, the loss should not be more than 0.3%.

Residue on Ignition Residue on ignition of L-Alanine should not be more than 0.2%.

Assay Proceed as directed under Assay of [L-Serine]

1 mL of 0.1 N perchloric acid solution = 8.909 mg $\text{C}_3\text{H}_7\text{NO}_2$

Alfalfa Extract

INS No.: 161b

CAS No.: 127-40-2

Definition Alfalfa Extract is a pigment prepared by the following procedure. Alfalfa is extracted with organic solvents such as acetone, isopropyl alcohol, ethyl alcohol, methyl alcohol, hexane, and methylene chloride. The extract is saponified to remove chlorophyll. Carotinoid is extracted and purified from the resultant with organic solvents. Its major pigment component is Lutein Dilutant, stabilizer, or solvent can be added for the purpose of color value adjustment and quality preservation.

Compositional Specifications of Alfalfa Extract

Content Color value ($E_{1cm}^{10\%}$) of Alfalfa Extract should be more than the indicated value.

Description Alfalfa Extract is deep yellowish brown liquid with a slight characteristic scent.

Identification Test Solution obtained in Color Value section have a maximum absorption band near 445 nm.

Purity (1) Arsenic : It should be no more than 4.0 ppm tested by Arsenic Limit Test.

(2) Lead : When 5.0 g of Alfalfa Extract is tested by Atomic Absorption Spectrophotometry or Inductively Coupled Plasma Emission Spectroscopy, its content should not be more than 10.0 ppm.

(3) Residual Solvents : When Alfalfa Extract is tested by Purity (5) for Paprika Extract Pigments, the content of residual solvents should be,

Acetone	}	Not more than 50ppm (individual or total if combined)
Isopropyl alcohol		
Methyl alcohol		
Hexane		

Methylene chloride Not more than 10ppm

Assay (Color Value) Appropriate amount of Alfalfa Extract is precisely weighted so that the absorption is within 0.3 ~ 0.7 and dissolved in chloroform so that the total volume is 100 mL (if it is water soluble, water is used). 1 mL of this solution is diluted to 100 mL with chloroform (Test Solution). Using chloroform as a reference solution, absorption A is measured at the maximum absorption near 445 nm with 1 cm path length. Color value is obtained using the following equation.

$$\text{Color Value } (E_{1cm}^{10\%}) = \frac{A \times 1,000}{\text{weight of the sample(g)}}$$

Alginic Acid

Chemical Formula: $(C_6H_3O_6)_n$

INS No.: 400

Equivalent measured value(Average) 200.00

CAS No.: 9005-32-7

Definition Alginic Acid is a carbohydrate obtained from brown algae (Phaeophyceae). Chemically, it is a linear glycuronoglycan consisting mainly of pyranose ring type of β -(1→4) linked D- mannuronic acid and α -1,4 -linked L- gluronic acid.

Compositional Specifications of Alginic Acid

Content On the dried basis, Alginic Acid contains not less than 20.0 and not more than of 23.0% carbon dioxide (CO_2), equivalent to not less than 91.0 and not more than of 104.5% alginic acid.

Description Alginic Acid is white, pale yellowish brown granule or filamentous powder having a slight characteristic odor and taste.

Identification (1) 1 g of Alginic Acid is dissolved in 150 mL of 0.1 N sodium hydroxide solution. When 1 mL of calcium chloride solution is added to 5 mL of this solution, voluminous gelatinous precipitates are formed.

(2) When 1 mL of diluted sulfuric acid is added to 5 mL of this solution, heavy gelatinous precipitates are formed.

(3) Approximately 5 mg of Alginic Acid is placed in a test tube, where 5 mL of water is added. 1 mL of freshly prepared solution of 1g naphtha resorcin in 100 mL alcohol and 5 mL of hydrochloric acid are added to the test tube, which is boiled for 3 minutes and cooled to 15°C. The content is transferred into a 30 mL separatory funnel with a stopper and the test tube is washed with 5 mL of water, which is added to the funnel. It is then extracted with 15 mL of isopropyl ether. Separately, a blank test is carried out. Isopropyl ether extract from the sample shows deeper violet color than that from the blank test.

Purity (1) Arsenic : It should be no more than 4.0 ppm tested by Arsenic Limit Test.

(2) Lead : When 5.0 g of Alginic Acid is tested by Atomic Absorption Spectrophotometry or Inductively Coupled Plasma Emission Spectroscopy, its content should not be more than 5.0 ppm.

(3) Cadmium : When 5.0 g of Alginic Acid is tested by Atomic Absorption Spectrophotometry or Inductively Coupled Plasma Emission Spectroscopy, its content should not be more than 1.0 ppm.

(4) Mercury : When 0.1 g of Alginic Acid is tested by Mercury Test Method, its content should not be more than 1.0 ppm.

(5) Insoluble substances : 1 g of Alginic Acid is dissolved in 100 mL of 0.1 N sodium hydroxide solution. It is then centrifuged and the supernatant is discarded. The residue is washed five time with water by mixing, centrifuged and decanted. The residue is transferred by means of water to a tared glass filter, dried for 1 hour at 105°C, cooled and weighed. The amount of the residue should not be more than 10

mg.

(6) pH : Suspension (3→100) of Alginic Acid should be pH 2.0 ~ 3.5.

(7) Total Viable Aerobic Count : When Alginic Acid is tested by Microbe Test Methods for Total Viable Aerobic Count (Number of General Germs) in General Test Method in 「Standards and Specifications for Foods」, it should not be more than 5,000 colonies per 1 g

(8) E. Coli : When Alginic Acid is tested by Microbe Test Methods for E. Coli in General Test Method 「Standards and Specifications for Foods」, it should be negative (-).

(9) Salmonella : When Alginic Acid is tested by Microbe Test Methods for Salmonella in General Test Method 「Standards and Specifications for Foods」, it should be negative (-).

(10) Number of Fungi : When Alginic Acid is tested by Microbe Test Methods for Number of Fungi in General Test Method in 「Standards and Specifications for Foods」, it should not be more than 500 colonies per 1 g

Ash 3 g of Alginic Acid is weighed and transferred into a porcelain crucible that is previously made weight constant and tared. It is then reduced to ash at 650°C until black carbon disappears. It is then allowed to cool down in a desiccator (silica gel). The amount of ash should not be more than 4%.

Loss on Drying 3 g of Alginic Acid is dried for 4 hours at 105°C. The weight loss on drying should not be more than 15%.

Assay 250mg of Alginic Acid is dried and analyzed as directed under the Content Analysis for 「Xanthan Gum」.

1 mL of 0.25 N sodium hydroxide solution = 25 mg alginic acid (Equivalent Value : 200.00)

Allyl Caproate



Chemical Formula: $\text{C}_9\text{H}_{16}\text{O}_2$

Molecular Weight: 156.22

Synonyms: Allyl hexanoate; 2-Propenyl hexanoate

CAS No.: 123-68-2

Compositional Specifications of Allyl Caproate

Content Allyl Caproate should contain not less than 98.0% of Allyl Caproate ($\text{C}_9\text{H}_{16}\text{O}_2$) 98.0%.

Description Allyl Caproate is colorless ~ pale yellow transparent liquid with a characteristic scent.

Identification To 1 mL of Allyl Caproate, add 5 mL of 10 % of alcoholic solution of KOH and heat in a water bath, its characteristic aroma disappears and an odor of allyl alcohol is produced. When this solution is acidified with dilute sulfuric acid, a scent of caproic acid is produced.

Purity (1) Specific Gravity : Specific gravity of Allyl Caproate should be within a range of 0.884~0.890.

(2) Refractive Index : Refractive Index n_D^{20} of Allyl Caproate should be within a range of 1.422~1.426.

(3) Clarity and Color of Solution : When 1 mL of Allyl Caproate is dissolved in 6 mL of 70% alcohol, the solution should be clear.

(4) Acid value : Acid value should not be more than 1 as determined by Acid Value in Flavoring Substances Test.

Assay Approximately 1g of Allyl Caproate is tested by Ester Value and Ester Content in Flavoring Substances Tests.

1 mL of 0.5 N alcoholic potassium hydroxide solution = 78.11mg $\text{C}_9\text{H}_{16}\text{O}_2$

Allyl Cyclohexanepropionate

Chemical Formula: $C_{12}H_{20}O_2$

Molecular Weight: 196.29

Synonyms: Allyl 3-cyclohexylpropionate

CAS No.: 2705-87-5

Compositional Specifications of Allyl Cyclohexanepropionate

Content Allyl Cyclohexanepropionate should contain not less than 98.0% of allyl cyclohexylpropionate ($C_{12}H_{20}O_2$).

Description Allyl Cyclohexanepropionate is a colorless to light yellow and transparent liquid having a characteristic odor.

Identification To 1 mL of Allyl Cyclohexanepropionate, add 5 mL of 10% alcoholic solution of potassium hydroxide. Heat in a water bath, attached a reflux condenser, for 30 minutes. The characteristic odor disappears, and an odor of alcohol develops.

Purity (1) Specific Gravity : Specific gravity should be within a range of 0.945 ~ 0.950

(2) Refractive Index : Refractive Index n_D^{20} should be within a range of 1.457 ~ 1.462

(3) Clarity and Color of Solution : When 1 mL of Allyl Cyclohexanepropionate is dissolved in 4 mL of 80% alcohol, the solution should be clear.

(4) Acid value : Acid value of Allyl Cyclohexanepropionate is tested by Acid Value in Flavoring Substance Test. It should not be more than 5.

Assay

Accurately weigh about 1.5 g of Allyl Cyclohexanepropionate, and proceed as directed under Ester Value and Ester Content in Flavoring Substances Tests.

0.5 N Ethanolic potassium hydroxide 1 mL = 98.15 mg of $C_{12}H_{20}O_2$

Allyl Isothiocyanate



Chemical Formula: $\text{C}_4\text{H}_5\text{NS}$

Molecular Weight: 99.15

Synonyms: 3-Isothiocyanatopropane

CAS No.: 57-06-7

Compositional Specifications of Allyl Isothiocyanate

Content Allyl Isothiocyanate should contain not less than 93.0% of allyl isothiocyanate ($\text{C}_4\text{H}_5\text{NS}$).

Description Allyl Isothiocyanate is a transparent and colorless to light yellow liquid having a strong and irritating odor.

Identification (1) Measure 3 mL of Allyl Isothiocyanate, add gradually 4 mL of sulfuric acid while cooling, and shake. A gas is evolved. The solution becomes transparent yellow and gradually viscous, and the strong, irritating odor disappears.

(2) To 2 mL of Allyl Isothiocyanate, add 3 mL of alcohol and 4 mL of ammonia solution, warm to about 50°C , and allow to stand. The solution is transparent at first, but after about 3 hours, crystals appear.

Purity (1) Specific Gravity : Specific gravity of Allyl Isothiocyanate should be within a range of 1.013 ~ 1.020.

(2) Refractive Index : Refractive Index n_D^{20} of Allyl Isothiocyanate should be within a range of 1.527 ~ 1.531.

(3) Carbon Disulfide, Petroleum Oil, Refined Oil, Fatty Oil : When 4 mL of sulfuric acid is added to 3 mL of Allyl Isothiocyanate, it should not turn red or turbid. It also should not form oily layer.

(4) Phenols and Thiocyanate Compounds : Measure 1.0 mL of Allyl Isothiocyanate, dissolve in 5 mL of alcohol, and add 1 drop of ferric chloride solution. Neither red nor blue color develops.

Assay Accurately weigh about 3 g of Allyl Isothiocyanate, and dissolve in alcohol to make 100 mL. Take 5 mL of this solution, add 5 mL of ammonia solution, 50 mL of 0.1 N silver nitrate. Equip with a reflux condenser, and heat for 1 hour in a water bath. Cool, add water to make exactly 100 mL, and filter through a dry filter paper. Discard about 10 mL of the initial filtrate. Take 50 mL of the subsequent filtrate, add 5 mL of nitric acid and 2 mL of ferric ammonium sulfate solution, and titrate the excess silver nitrate with 0.1 N ammonium thiocyanate. Perform a blank test in the same manner, separately.

1 mL of 0.1 N silver nitrate = 4.958 mg of $\text{C}_4\text{H}_5\text{NS}$

Aluminium Ammonium Sulfate

Crystal : Ammonium Alum

Dried : Burnt Ammonium Alum

Chemical Formula: $\text{AlNH}_4(\text{SO}_4)_2 \cdot 0 \sim 12\text{H}_2\text{O}$

INS No.: 523

CAS No.: 7784-25-0(anhydride)

Synonyms: Ammonium alum

7784-26-

1(12hydrates)

Definition Aluminum Ammonium Sulfate occurs as crystals (dodecahydrate) called Aluminum Ammonium Sulfate and a dried substance called Aluminum Ammonium Sulfate (dried).

Compositional Specifications of Aluminum Ammonium Sulfate

Content Aluminum Ammonium Sulfate, when calculated on the dried basis at 200°C for 4 hours, should contain not less than 96.5% of aluminum ammonium sulfate [$\text{AlNH}_4(\text{SO}_4)_2$].

Description Aluminum Ammonium Sulfate occurs as colorless to white crystals, powder flakes, granules, or lumps. It is odorless and has an astringent taste.

Identification Aluminum Ammonium Sulfate solution (1→50) responds to all tests for Aluminum Salt, Ammonium Salt, and Sulfate (A) and (B) in Identification.

Purity (1) Clarity and Color of Solution or water-insoluble substances : Proceed as directed under Purity (1) in 「Aluminum Potassium Sulfate」.

(2) Arsenic : It should be no more than 4.0 ppm tested by Arsenic Limit Test.

(3) Lead : Aluminum Ammonium Sulfate is tested by Purity (2) for 「Sodium Metaphosphate」(not more than 3.0 ppm).

(4) Mercury : When Aluminum Ammonium Sulfate is tested by Mercury Limit Test, its content should not be more than 1.0 ppm.

(5) Selenium : 0.2 g of Aluminum Ammonium Sulfate is precisely weighed and is tested by purity (6) for 「Sulfuric acid」(not more than 30 ppm).

(6) Fluoride : 1 g of Aluminum Ammonium Sulfate is precisely weighed and is tested by Purity (8) for 「Calcium Citrate」(not more than 30 ppm).

(7) Alkali metals and alkali earth metals : Weigh 1 g of Aluminum Ammonium Sulfate, dissolve in 100 mL of water, and add sufficient amount of ammonia solution to make it alkaline (indicator : methyl red solution). Boil until the precipitate of aluminum is no longer formed and filter it. The filtrate is evaporated to dryness and ignited, the amount of residue should not be more than 5 mg.

(8) Iron : 0.054 g of Aluminum Ammonium Sulfate, previously dried for 4 hours at 200°C, dissolve in 6 mL of nitric acid(1→10) and water to make 20 mL. After adding 0.05 mg of ammonium peroxydisulfate and 5 mL ammonium thiocyanate solution(2→25), shake and mix, and 15 mL of n-butyl alcohol is added

and mixed by shaking. The color of n-butyl alcohol layer should not be deeper than that of the color standard solution. The color standard solution is prepared by using 1 mL of iron standard solution with adding 6 mL of nitric acid(1→10) and water to make 20 mL, following the same procedure as the sample.

Assay Proceed as directed under Assay for 「Aluminum Potassium Sulfate」.

1 mL of 0.01 M EDTA = 2.371 mg of $\text{AlNH}_4(\text{SO}_4)_2$

Aluminium Potassium Sulfate

Crystal: Potassium Alum or Alum

Desiccated: Burnt Alum

Chemical Formula: $\text{AlK}(\text{SO}_4)_2 \cdot 0 \sim 12\text{H}_2\text{O}$

INS No.: 522

Synonyms: Potassium alum

CAS No.:

10043-67-1(anhydrous)

7784-24-9(12hydrates)

Definition Aluminum Potassium Sulfate occurs as crystals (dodecahydrate) called Aluminum Potassium Sulfate and a dried substance called Aluminum Potassium Sulfate (dried).

Compositional Specifications of Aluminum Potassium Sulfate

Content Aluminum Potassium Sulfate, when calculated on the dried basis for 4 hours at 200°C, should contain not less than 96.5% of aluminum potassium disulfate [$\text{AlK}(\text{SO}_4)_2$]

Description Aluminum Potassium Sulfate occurs as colorless to white crystals, powder, flakes, granules, or lumps. It is odorless and has an astringent taste.

Identification (1) The aqueous solution of Aluminum Potassium Sulfate (1→20) responds to all tests for Aluminum Salt and Sulfate (A) and (C) in Identification.

(2) Aluminum Potassium Sulfate solution (1→20) responds to the tests for Potassium Salt (A) in Identification.

Purity (1) Clarity and Color of Solution or water-insoluble substances : To 1 g of crystals of Aluminum Potassium Sulfate, 10 mL of water is added and dissolved. It is colorless and shall be almost clear. For water-insoluble substances, weigh 2 g of the dried substance, and add 200 mL of water. Heat for 10 minutes, cool, glass filter through a glass filter (IG4) that is previously dried at 105°C for 2 hours, the amount should not be more than 40 mg(no more than 2.0 %).

(2) Arsenic : It should be no more than 4.0 ppm tested by Arsenic Limit Test.

(3) Lead : Aluminum Potassium Sulfate is tested by purity (2) for 「Sodium Metaphosphate」(not more than 5.0 ppm).

(4) Mercury : When Aluminum Potassium Sulfate is tested by Mercury Limit Test, its content should not be more than 1.0 ppm.

(5) Selenium : 0.2 g of Aluminum Potassium Sulfate is precisely weighed and is tested by purity (6) for 「Sulfuric acid」(not more than 30 ppm).

(6) Fluoride : 1 g of Aluminum Potassium Sulfate is precisely weighed and is tested by purity (8) for 「Calcium Citrate」(not more than 30 ppm).

(7) Iron : 0.054 g of Aluminum Potassium Sulfate, previously dried for 4 hours at 200°C, is dissolved in 6 mL of nitric acid(1→10) and water to make 20 mL. Add 0.05 mg of ammonium peroxydisulfate and 5 mL ammonium thiocyanate solution(2→25), shake and mix, and 15 mL of n-butyl alcohol is added and mixed by shaking. The color of n-butyl alcohol layer should not be deeper than that of the color standard solution. The color standard solution is prepared by using 1 mL of iron standard solution with adding 6 mL of nitric acid(1→10) and water to make 20 mL, following the same procedure as the sample.

Assay Accurately weigh about 0.8 g of powdered Aluminum Potassium Sulfate, previously dried at 200°C for 4 hours, add 100 mL of water, dissolve by heating a water bath and shaking, filter, and wash the insoluble residue thoroughly with water. Combine the filtrate and the washings, add water to make exactly 200 mL. Measure exactly 25 mL of this solution, add exactly 50 mL of 0.01 M EDTA, and heat to boiling. After cooling, add 7 mL of sodium acetate solution and 85 mL of absolute ethanol, and titrate the excess EDTA with 0.01 M zinc acetate (indicator : 3 drops of xylenol orange solution) until the yellow color of the solution changes to red.

$$1 \text{ mL of } 0.01 \text{ EDTA} = 2.582 \text{ mg of } \text{AlK}(\text{SO}_4)_2$$

Amidated Pectin

INS No.: 440

CAS No.: 56645-02-4

Definition Amidated Pectin is polymer of refined carbohydrate obtained by processing pectin, which is obtained from extracting citrus fruits or apples with hot water or acidic aqueous solution, with ammonia in alkali condition. The main parts of pectin chain is composed of a-1,4 combination of D-galacturonic acid unit. Some of Carboxyl Group are methyl esterificated and amidated. Others exist as the form of free acid or ammonium, potassium, and sodium salt. Upon the purpose of use, sugars can be added to standardize the property of matter or food additives which is used as buffer for adjusting of acidity can be used.

Compositional Specifications of Amidated Pectin

Content Amidated Pectin is white~brown pale powder or granule. It is odorless or has slightly characteristic odor.

Identification (1) To certain amount of 1% of Amidated Pectin solution, same amount of alcohol is added, then precipitate of transparent gelatin is formed.

(2) To 10 mL of 1% Amidated Pectin solution, 1 mL of nitric acid thorium is added, mixed, and set aside for 2 minutes, then precipitate or gel is formed.

(3) To 5 mL of 1% Amidated Pectin solution, 1 mL of sodium hydroxide is added, set aside for 15 minutes at the room temperature, then gel is formed.

(4) To the gel formed from (3), 1 mL of hydrochloric acid is added, acidified, shaken well, then voluminous colorless gelatin precipitate formed. When it is boiled, white cohesion is formed.

Purity (1) Arsenic : It should be no more than 4.0 ppm tested by Arsenic Limit Test.

(2) Lead : When 5.0 g of Amidated Pectin is tested by Atomic Absorption Spectrophotometry or Inductively Coupled Plasma Emission Spectroscopy, its content should not be more than 5.0 ppm.

(3) Cadmium : When 5.0 g of Amidated Pectin is tested by Atomic Absorption Spectrophotometry or Inductively Coupled Plasma Emission Spectroscopy, its content should not be more than 1.0 ppm.

(4) Mercury : When Amidated Pectin is tested by Mercury Limit Test, its content should not be more than 1.0 ppm.

(5) Residual solvent : 0.1 g of Amidated Pectin is precisely weighed, 10 mL of diluted inner standard solution(1→25) is added, the stopper is placed, and mixed until being dispersed equally. This solution is transferred to ultrafilter centrifugal filtration tube, centrifuged for 30 minutes at 5,000rpm, and the filtrate is test solution. However, tert-butyl alcohol(1→1,000) is used as inner standard solution. Separately, 0.1 g each of methyl alcohol and isopropyl alcohol is precisely measured and water is added to 100 mL. Again, 10 mL of this solution and 4 mL of inner standard solution are weighed and

water is added to make 100 mL, mixed standard solution. 2µl each of test solution and mixed standard solution is weighed and injected into gas chromatography under following operation condition. Ratio of methyl alcohol and isopropyl alcohol peak against tert-butyl alcohol peak, Q_{T1} , Q_{T2} and Q_{S1} , Q_{S2} , is measured respectively, and measure the content of methyl alcohol and isopropyl alcohol under following equation, it should be not more than 1.0% as individual or total if combined

$$\text{Content of methyl alcohol (\%)} = \frac{\text{Weight of methyl alcohol(g)}}{\text{Weight of sample(g)}} \times \frac{Q_{T1}}{Q_{S1}}$$

$$\text{Content of isopropyl alcohol (\%)} = \frac{\text{Weight of isopropyl alcohol(g)}}{\text{Weight of sample(g)}} \times \frac{Q_{T2}}{Q_{S2}}$$

Q_{T1} : Ratio of methyl alcohol peak against tert-butyl alcohol peak in Test Solution

Q_{T2} : Ratio of 2-propyl alcohol peak against tert-butyl alcohol peak in Test Solution

Q_{S1} : Ratio of methyl alcohol peak against tert-butyl alcohol peak in mixed standard Solution

Q_{S2} : Ratio of isopropyl alcohol peak against tert-butyl alcohol peak in mixed standard Solution

Operation Condition

Column : PLOT Q or its equivalent

Detector : Hydrogen Flame Ionization Detector (FID)

Temperature at injection hole : 200°C

Column Temperature : 120°C

Detector Temperature : 300°C

Carrier gas : Nitrogen or Helium

(6) Amide group : 5 g of Amidated Pectin is precisely weighed and transferred into a beaker, 5 mL of hydrochloric acid and 100 mL of 60% ethyl alcohol are added, stirred for 10 minutes, filtered with a glass filter(1G3 or its equivalent). 60% of residue in a glass filter is washed with 15 mL each of 60% mixture of ethyl alcohol: hydrochloric acid(20:1) six times, washed solution is washed with 60% ethyl alcohol until it doesn't react by Chloride Limit Test, and washed with 20 mL of ethyl alcohol again. It is dried for 2.5 hours at 105°C, cooled in a desiccator, and weighed. The amount which corresponds to 1/10 of the weight of the dried substance is precisely weighed. Then the weight is W(mg). To this solution, 2 mL of ethyl alcohol is added and wetted, 100 mL of freshly boiled and cooled water is added, shaken, and mixed. 5 drops of phenolphthalein solution, titrated with 0.1N sodium hydroxide solution, and the consumed amount of the solution is V_1 (mL). 20 mL of 0.5N sodium hydroxide solution is precisely weighed, added, shaken well, mixed, and set aside for 15 minutes. Again, 20 mL of 0.5N hydrochloric acid is precisely weighed, added, titrated with 0.1N sodium hydroxide solution until the red color disappears, and the consumed amount of this solution is V_2 (mL). However, the final point is when the color of solution becomes slightly red after shaking vigorously. Titrated solution is transferred to 500 mL flask for decomposition, which is apparatus of Total Kjeldahl Nitrogen Test

(nitrogen determination method). After distilling apparatus is attached, 20 mL of 0.1N hydrochloric acid and 150 mL of freshly boiled and cooled water are into flask for absorption. Tip of the condenser is submerged in the solution, 20 mL of sodium hydroxide(1→20) is transferred into a flask for decomposition, heated while caring generating bubbles, and 80~120 mL of distillate is obtained. It is titrated with 0.1N sodium hydroxide solution (indicator : Methyl red solution), the consumed amount of the solution is S(mL). Separately, perform the blank test, and the consumed amount of 0.1N sodium hydroxide is B(mL). When measure the content of amide group to against the total carboxyl, its content should not be more than 25%.

The content of amide group to against the total carboxyl (%)=
$$\frac{B-S}{V_1+V_2+(B-S)} \times 100$$

(7) Galacturonic acid : When the content of galacturonic acid is measured under following equation with using W, V₁, V₂, B, S obtained from (6) Purity, its amount should not be more than 65%.

Content of Galacturonic acid(%)=
$$\frac{19.41 \times [V_1+V_2+(B-S)]}{W} \times 100$$

(8) Sulfur dioxide : When Amidated Pectin is tested by Assay in sulfurous acid, hyposulfurous acid, and their salts test method in General Test Method in 「Standards and Specifications for Foods」, it should not be more than 50 ppm.

(9) Acid-Insoluble Ash : When 3 g of Amidated Pectin is tested by Ash and Acid-Insoluble Ash Limit Test, it should not be more than 1.0%.

Loss on Drying When 3g of Amidated Pectin is dried for 2 hours at 105°C, the weight loss should not be more than 12%.

Ammonium Alginate

Chemical Formula: $(C_6H_7O_6NH_4)_n$

Equiv wt, actual(avg.): 217.00

INS No.: 403

Synonyms: Ammonium salt of alginate

CAS No.: 9005-34-9

Compositional Specifications of Ammonium Alginate

Content Ammonium Alginate, when calculated on the dried basis, should contain 18.0~21.0% carbon dioxide (CO₂). This corresponds to 88.7~103.6% ammonium alginate.

Description Ammonium Alginate occurs as white ~ pale yellow fiber, granule, or powder.

Identification (1) When 1 mL of calcium chloride solution is added to 5 mL aqueous solution (1→100) of Ammonium Alginate, voluminous gelatinous precipitates are formed.

(2) When 1 mL of dilute acid is added to 10 mL of Test Solution in (1), heavy gelatinous precipitates are formed.

(3) Proceed as directed under Identification (3) for 「Alginic Acid」.

(4) Approximately 1 g of Ammonium Alginate is transferred into a test tube. Upon mixing with 5 mL of sodium hydroxide solution, smell of ammonia is generated.

Purity

(1) Arsenic : It should be no more than 4.0 ppm tested by Arsenic Limit Test.

(2) Lead : When 5.0 g of Ammonium Alginate is tested by Atomic Absorption Spectrophotometry or Inductively Coupled Plasma Emission Spectroscopy, its content should not be more than 2.0 ppm.

(3) Cadmium : When 5.0 g of Ammonium Alginate is tested by Atomic Absorption Spectrophotometry or Inductively Coupled Plasma Emission Spectroscopy, its content should not be more than 1.0 ppm.

(4) Mercury : When Ammonium Alginate is tested by Mercury Limit Test, its content should not be more than 1.0 ppm.

(5) Total Viable Aerobic Count : When Ammonium Alginate is tested by Microbe Test Methods for Total Viable Aerobic Count (Number of General Germs) in General Test Method in 「Standards and Specifications for Foods」, it should not be more than 5,000 per 1 g

(6) E. coli : When Ammonium Alginate is tested by Microbe Test Methods for E. coli in General Test Method 「Standards and Specifications for Foods」, it should be negative (-).

(7) Salmonella : When Ammonium Alginate is tested by Microbe Test Methods for Salmonella in General Test Method 「Standards and Specifications for Foods」, it should be negative (-).

(8) Fungi : When Ammonium Alginate is tested by Microbe Test Methods for Fungi in General Test Method in 「Standards and Specifications for Foods」, it should not be more than 500 per 1 g

Ash Ammonium Alginate, previously dried, tested by Ash for「Alginate」, the amount of ash should not

be more than 4.0%.

Loss on Drying When 3 g of Ammonium Alginate is dried for 4 hours at 105°C, the loss should not be more than 15.0%.

Assay Approximately 0.25 g of Ammonium Alginate is precisely weighed and analyzed by the procedure in Content Analysis for 「Xanthan Gum」.

1 mL of 0.25 N sodium hydroxide solution = 27.12 mg ammonium alginate
(Equivalent Value : 217.00)

Ammonium Bicarbonate

Ammonium Hydrogen Carbonate

Chemical Formula: NH_4HCO_3

Molecular Weight: 79.06

INS No.: 503(ii)

Synonyms: Ammonium hydrogen carbonate

CAS No.: 1066-33-7

Compositional Specifications of Ammonium Bicarbonate

Content Ammonium Bicarbonate should not be less than 20.0% and more than 30.0% of ammonia ($\text{NH}_3 = 17.03$).

Description Ammonium Bicarbonate occurs as white or translucent crystals, crystalline powder, or lumps, having an strong odor of ammonia.

Identification Ammonium Bicarbonate responds to the tests for Ammonium Salt and (A) Bicarbonate in Identification.

Purity (1) Clarity and Color of Solution : When 2 g of Ammonium Bicarbonate is dissolved in 20 mL of water, the solution should not be more than almost clear.

(2) Arsenic : It should be no more than 4.0 ppm tested by Arsenic Limit Test.

(3) Lead : Ammonium Bicarbonate is tested by purity (2) for 「Sodium Metaphosphate」(not more than 2.0 ppm).

(4) Mercury : When Ammonium Bicarbonate is tested by Mercury Limit Test, its content should not be more than 1.0 ppm.

(5) Sulfate : When 4 g of Ammonium Bicarbonate is tested by Sulfate Limit Test, its content should not be more than the amount that corresponds to 0.25 mL of 0.01 N sulfuric acid (not more than 0.003%).

(6) Residue on Evaporation : 20 g of Ammonium Bicarbonate is weighed into a platinum crucible, 50 mL of water is added, mixed, and evaporated to dryness in a water bath. It is dried for 30 minutes at 105°C , and cooled in desiccator and weighed. The amount should not be more than 10 mg (not more than 0.05%).

(7) Chloride : When 2 g of Ammonium Bicarbonate is tested by Chloride Limit Test, its content should not be more than the amount that corresponds to 0.2 mL of 0.01 N hydrochloric acid.

Residue on Ignition When thermogravimetric analysis is done with approximately 10 g of Ammonium Bicarbonate, the amount of residues should not be more than 0.01%.

Assay Proceed as directed under Assay in 「Ammonium Carbonate」.

Ammonium Carbonate

INS No.: 503(i)

Synonyms: Ammonium carbamate

CAS No.: 10361-29-2

Compositional Specifications of Ammonium Carbonate

Content Ammonium Carbonate should contain within a range of 30.0~34.0% of ammonia ($\text{NH}_3 = 17.03$).

Description Ammonium Carbonate occurs as white or translucent crystals, crystalline powder, or lumps, having an strong odor of ammonia.

Identification Ammonium Carbonate responds to the tests for Ammonium Salt and Carbonate in Identification.

Purity (1) Clarity and Color of Solution : When 2 g of Ammonium Carbonate is dissolved in 20 mL of water, the solution should not be more than almost clear.

(2) Arsenic : It should be no more than 4.0 ppm tested by Arsenic Limit Test.

(3) Lead : Ammonium Carbonate is tested by purity (2) for 「Sodium Metaphosphate」(not more than 2.0 ppm).

(4) Mercury : When Ammonium Carbonate is tested by Mercury Limit Test, its content should not be more than 1.0 ppm.

(5) Sulfate : When 4 g of Ammonium Carbonate is tested by Sulfate Limit Test, its content should not be more than the amount that corresponds to 0.25 mL of 0.01 N sulfuric acid. (not more than 0.003%).

(6) Residue on Evaporation : 20 g of Ammonium Carbonate is weighed into a platinum crucible, 50 mL of water is added, mixed, and evaporated to dryness in a water bath. It is dried for 30 minutes at 105°C, and cooled in desiccator and weighed. The amount should not be more than 10 mg. (not more than 0.05%)

(7) Chloride : When 2 g of Ammonium Carbonate is tested by Chloride Limit Test, its content should not be more than the amount that corresponds to 0.15 mL of 0.01 N hydrochloric acid. (not more than 0.003%)

Residue on Ignition When thermogravimetric analysis is done with 10 g of Ammonium Carbonate, the amount of residues should not be more than 0.01%.

Assay Accurately weigh a flask with a ground-glass stopper containing about 30 mL of water, add about 2.5 g of Ammonium Carbonate, and weigh again accurately. Transfer into a 250 mL volumetric flask, and add water to make exactly 250 mL. Measure exactly 25 mL of this solution, and add gradually 50 mL of 0.1 N hydrochloric acid, exactly measured. Titrate the excess hydrochloric acid with 0.1 N sodium hydroxide (indicator : 4~5 drops of bromophenol blue solution).

1 mL of 0.1 N hydrochloric acid = 1.703 mg NH₃

Ammonium Chloride

Chemical Formula: NH_4Cl

Molecular Weight: 53.50

INS No.: 510

Synonyms: Ammonium muriate; Sal ammoniac

CAS No.: 12125-02-9

Compositional Specifications of Ammonium Chloride

Content Ammonium Chloride, when calculated on the dried basis, should contain not less than 99.0% of ammonium chloride (NH_4Cl).

Description Ammonium Chloride occurs as white crystalline powder or crystalline lumps, having a salty and fresh taste.

Identification Ammonium Chloride responds to the tests for Ammonium Salt and Chloride in Identification.

Purity (1) Clarity and Color of Solution : 2 g of Ammonium Chloride is dissolved in 20 mL of water. The turbidity of resulting solution should not be more than almost clear.

(2) Arsenic : It should be no more than 4.0 ppm tested by Arsenic Limit Test.

(3) Lead : Ammonium Chloride is tested by purity (2) for 「Sodium Metaphosphate」(not more than 2.0 ppm).

Loss on Drying When Ammonium Chloride is dried for 4 hours in a vacuum desiccator(silica-gel), the weight loss should not be more than 2%.

Residue on Ignition When thermogravimetric analysis is done with Ammonium Chloride, the residues should not be more than 0.5%.

Assay 3 g of Ammonium Chloride, previously dried and accurately weighed, is tested by Assay for 「Ammonium Sulfate」.

1 mL of 0.2 N sulfuric acid = 10.70 mg NH_4Cl

Ammonium Hydroxide

Chemical Formula: NH_4OH

Molecular Weight: 35.05

INS No.: 527

Synonyms: Strong ammonia solution; Stronger
ammonium water

CAS No.: 1336-21-6

Compositional Specifications of Ammonium Hydroxide

Content Ammonium Hydroxide should contain within a range of 27.0~30.0% of ammonia ($\text{NH}_3 = 17.03$).

Description Ammonium Hydroxide is colorless transparent liquid with a characteristic odor.

Identification When Ammonium Hydroxide is approached with a glass rod wetted with hydrochloric acid, thick white smoke is generated.

Purity (1) Lead : When 5.0 g of Ammonium Hydroxide is tested by Atomic Absorption Spectrophotometry or Inductively Coupled Plasma Emission Spectroscopy, its content should not be more than 2.0 ppm.

(2) Arsenic : It should be no more than 4.0 ppm tested by Arsenic Limit Test.

(3) Residue on Evaporation : 11 mL of (approximately 10 g) Ammonium Hydroxide is evaporated on a platinum or porcelain dish (previously weighed) and dried for 1 hour at 105°C . The residue should not be more than 0.02%.

(4) Readily oxidizing material : When 6 mL of water, slightly excess amount of dilute sulfuric acid, and 0.1 mL of 0.1 N potassium permanganate are added to 4 mL of Ammonium Hydroxide, pale red color in the solution should not disappear within 10 minutes.

Assay 35 mL of 1 N sulfuric acid is transferred into a flask, which is sealed with a stopper. This additive is cooled below 10°C . Using a 10 mL graduated pipette, cooled ammonia is drawn from the bottom if possible. Outer wall of the pipette is wiped clean and first few mL are discarded. 2 mL of ammonia is added to the flask. At this time, at least 1 mL should be left in the pipette. The flask is capped with a stopper and mixed. It is weighed again to obtain the amount of the sample. Excess acid is then titrated with 1 N sodium hydroxide solution. (indicator : 1 ~ 2 drops of methyl red solution).

1 mL of 1 N sulfuric acid = 17.03 mg NH_3

Ammonium Molybdate

Chemical Formula: $(\text{NH}_4)_6\text{Mo}_7\text{O}_{24} \cdot 4\text{H}_2\text{O}$

Molecular Weight: 1235.86

CAS No.: 12054-85-2

Compositional Specifications of Ammonium Molybdate

Content Ammonium Molybdate should contain within a range of 99.3 ~ 101.8% of Ammonium Molybdate $((\text{NH}_4)_6\text{Mo}_7\text{O}_{24} \cdot 4\text{H}_2\text{O})$.

Description Ammonium Molybdate is white~light green crystalline powder with slight odor of ammonia.

Identification 0.6 g of Ammonium Molybdate is dissolved in the mixture of 1.4 mL of water and 1.45 mL of ammonia solution. The mixture is cooled, 7.2 mL of the solution, which 3.2 mL of nitric acid and 4 mL of water are mixed and cooled, is added while stirring slowly. Set aside for 24~48 hours, filter, and add 2 mL of disodium phosphate to 5 mL of filtrate. Then yellow filtrate generates and it dissolves in excess amount of ammonia solution.

Purity (1) Chloride : When 0.5g of Ammonium Molybdate is tested by Chloride Limit Test, the content should not be more than the amount that correspond to 0.30 mL of 0.001 N hydrochloric acid.

(2) Sulfate : When 0.25 g of Ammonium Molybdate is tested by Sulfate Limit Test, the content should not be more than the amount that correspond to 1.0 mL of 0.001 N sulfuric acid.

(3) Phosphate : When 20 g of Ammonium Molybdate is precisely weighed and dissolved in 3N ammonia solution to make 100 mL. 3.5 mL of iron nitrate (1→10) is added and set aside for 15 minutes. Gradually heat it, filter when the precipitates are cohered, and wash the residue with 1.5N ammonia solution several times. Dissolve the residue with 60 mL of warm 4N nitric acid, 13 mL of ammonia solution is added and bring to 40°C. 50 mL of Ammonium Molybdate solution is added, shaken for 5 minutes, set aside for 2 hours at 40°C, then the precipitates should not be more than precipitates of standard solution (not more than 5 ppm). However, 144.3 mg of dried potassium phosphate is dissolved in water to make 1,000 mL, and 1.0 mL of this solution is dissolved in 3N ammonia solution to make 100 mL, standard solution.

(4) Magnesium salt and alkali salt : 5g of Ammonium Molybdate is precisely weighed and dissolved in water to make 50 mL and filtered. To the filtrate, 0.5 g of sodium carbonate and 25 mL of 2.5N sodium hydroxide are added, boiled for 5 minutes, filtered with filter paper, and the residue is washed with 1N ammonia solution. Measure the residue after it is heat-treated for 30 minutes at $800 \pm 25^\circ\text{C}$, the weight of residue should not be more than 1mg (not more than 0.02%).

(5) Lead : Ammonium Molybdate is tested by Purity (2) for 「Sodium Metaphosphate」 (not more than 2.0 ppm).

(6) Water-insoluble substances : To 20 g of Ammonium Molybdate, water is added to make 200mL, heat

for 1 hour in a water bath, and filter it. Wash the residue with hot water and dry for 2 hours at 105°C, then its content should not be more than 1 mg (not more than 0.005%).

(7) Nitrate : 1 g of Ammonium Molybdate is precisely weighed and dissolved in 0.05% sodium chloride to make 10 mL. 0.1 mL of indigo carmin solution dissolved in 3.6 N sulfuric acid is added, then blue color doesn't completely disappear in 5 minutes.

Assay 1 g of Ammonium Molybdate is precisely weighed and dissolved in the mixture of 10 mL of water and 1 mL of ammonia solution, and diluted with water to 250 mL. To 50 mL of the filtrate of this solution, 250 mL of water, 20 g of ammonium chloride, 15 mL of hydrochloric acid, and 0.15 mL of methy orange solution are added, heated until it boils, and 18 mL of lead acetate solution(9.5 →100) is added. Saturated acetate ammonium solution is added while stirring until yellow color develops, 15 mL of lead acetate solution (9.5→100) is added and heated until precipitates generate at the temperature below boiling point. Filter it and wash the residue with the mixture of water, saturated acetate ammonium solution, mixture of nitric acid (890:100:10) 7~8 times. Lastly, wash it with hot water 3 times, heat-treat at 560 ~ 625°C and measure the weight of lead molybdate.

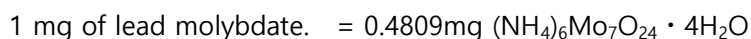

Ammonium Persulfate

Chemical Formula: $(\text{NH}_4)_2\text{S}_2\text{O}_8$

INS No.: 923

Molecular Weight: 228.20

CAS No.: 7727-54-0

Compositional Specifications of Ammonium Persulfate

Content Ammonium Persulfate should contain not less than 95.0% of ammonium persulfate $[(\text{NH}_4)_2\text{S}_2\text{O}_8]$.

Description Ammonium Persulfate occurs as colorless crystals or as a white crystalline powder.

Identification (1) To 0.5 g of Ammonium Persulfate, add 5 mL of sodium hydroxide solution, and a gas with an odor of ammonia is evolved after heating. This gas changes from red litmus paper wetted with water to blue litmus paper.

(2) Add 2 ~ 3 drops of manganese sulfate solution (1→100) to 5 mL of diluted sulfuric acid. It is warmed after adding 1 drop of silver nitrate solution and 0.2 g of Ammonium Persulfate. Then, the solution develops a pink color.

Purity (1) Clarity and Color of Solution : When 1 g of Ammonium Persulfate is dissolved in 10 mL of water, the solution should be colorless and should not be more almost clear.

(2) Arsenic : It should be no more than 4.0 ppm tested by Arsenic Limit Test.

(3) Lead : Ammonium persulfate is tested by Purity (2) for 「Sodium Metaphosphate」(not more than 2.0 ppm).

Residue on Ignition When thermogravimetric analysis is done with Ammonium Persulfate (gently at first, then strongly until the weight becomes constant), the residue should not be more than 0.2%.

Assay Dissolve about 1.5 g of Ammonium Persulfate, precisely weighed, in water make to 250 mL. 50 mL of the solution is mixed with 40 mL of 0.1 N ammonium ferrous sulfate solution and 5 mL of phosphoric acid. The excess amount of ammonium ferrous sulfate is titrated with 0.1 N potassium permanganate solution. Separately, a blank test is carried out by the same method.

0.1 N ammonium ferrous solution 1 mL = 11.41 mg $(\text{NH}_4)_2\text{S}_2\text{O}_8$

Ammonium Phosphate, Dibasic

Chemical Formula: $(\text{NH}_4)_2\text{HPO}_4$

Molecular Weight: 132.06

INS No.: 342(ii)

Synonyms: Diammonium hydrogen phosphate;
Diammonium phosphate

CAS No.: 7783-28-0

Compositional Specifications of Ammonium Phosphate, Dibasic

Content Ammonium Phosphate, Dibasic should contain within a range of 96.0~102.0% of dibasic ammonium phosphate $[(\text{NH}_4)_2\text{HPO}_4]$.

Description Ammonium Phosphate, Dibasic is colorless ~ white crystallite or white crystalline powder.

Identification Ammonium Phosphate, Dibasic responds to test of Ammonium Salts and Phosphate in Identification.

Purity (1) pH : pH of Ammonium Phosphate, Dibasic solution (1→100) is measured using a glass electrode and should be within a range of 7.6 ~ 8.4.

(2) Arsenic : It should be no more than 4.0 ppm tested by Arsenic Limit Test.

(3) Lead : Ammonium Phosphate, Dibasic is precisely weighed and is tested by purity (2) for 「Sodium Metaphosphate」, its content should not be more than 4.0 ppm.

(4) Fluoride : 1 g of Ammonium Phosphate, Dibasic is precisely weighed and is tested by purity (8) for 「Calcium Citrate」, its content should not be more than 10 ppm.

Assay Approximately 2 g of Ammonium Phosphate, Dibasic, accurately weighed, and dissolve in 50 mL of water. The solution is kept at 15°C and titrated with 1 N hydrochloric acid (indicator : 3 ~ 4 drops of Methyl Orange.Xylene Cyanol FF solution).

1 mL of 1 N hydrochloric acid = 132.1 mg $(\text{NH}_4)_2\text{HPO}_4$

Ammonium Phosphate, Monobasic

Chemical Formula: $\text{NH}_4\text{H}_2\text{PO}_4$

Molecular Weight: 115.03

INS No.: 342(i)

Synonyms: Ammonium dihydrogen phosphate;
Acid ammonium phosphate

CAS No.: 7722-76-1

Compositional Specifications of Ammonium Phosphate, Monobasic

Content Ammonium Phosphate, Monobasic should contain within a range of 96.0~102.0% of Ammonium Phosphate, Monobasic ($\text{NH}_4\text{H}_2\text{PO}_4$).

Description Monobasic Ammonium Phosphate is colorless ~ white crystallite, crystalline powder or granule.

Identification Ammonium Phosphate, Monobasic responds to test of Ammonium Salt and Phosphate in Identification.

Purity (1) pH : Ammonium Phosphate, Monobasic solution (1→100) is measured using a glass electrode and pH should be within a range of 4.3 ~ 5.0.

(2) Arsenic : It should be no more than 4.0 ppm tested by Arsenic Limit Test.

(3) Lead : Ammonium Phosphate, Monobasic is precisely weighed and is tested by purity (2) for 「Sodium Metaphosphate」, its content should not be more than 4.0 ppm.

(4) Fluoride : 1 g of Ammonium Phosphate, Monobasic is precisely weighed and is tested by purity (8) for 「Calcium Citrate」, its content should not be more than 10 ppm.

Assay Dissolve 3 g of Ammonium Phosphate, Monobasic, previously dried and accurately weighed, in 30 mL of water. 5 g of sodium chloride is added, which is dissolved by shaking. While the solution is kept at 15°C, it is titrated with 1 N sodium hydroxide solution (Indicator : 3 ~ 4 drops of thymol blue solution)

1 mL of 1 N sodium hydroxide solution = 115.0 mg $\text{NH}_4\text{H}_2\text{PO}_4$

Ammonium Phosphatides

Synonyms: Ammonium salts of phosphatidic acid

INS No.: 442

Compositional Specifications of Ammonium Phosphatides

Content Ammonium phosphatides should contain 3.0~3.4% of phosphorous(P) and 1.2~1.5% of ammoniacal nitrogen(N).

Description Ammonium phosphatides are lustrous semi-solid, oily solid or liquid.

Identification

- (1) Ammonium phosphatides are soluble in fats, partially soluble in ethanol and acetone, and insoluble in water.
- (2) Add 2g of anhydrous sodium carbonate to 1g of ammonium phosphatides. After ashing and cooling down them, 5mL of water and 5mL of nitric acid are added to the residue. Add ammonium molybdate solution to the dissolved solution and heat to boiling. A yellow precipitate is made.
- (3) Add 25mL of 0.5N ethanolic potassium hydroxide solution to 1g of ammonium phosphatides, heat in a water bath equipped with a reflux condenser for 1hour. A gas with odor of Ammonia is evolved from the end of the reflux condenser and the gas becomes the color of a red litmus paper on moist to blue. when the residue cool down to 0°C, a precipitate of potash soap is made.
- (4) Add 25mL of 0.5N ethanolic potassium hydroxide solution to 1g of ammonium phosphatides, heat in a water bath equipped with a reflux condenser for 1hour. 15mL of water and 6mL of dilute hydrochloric acid are added. After adding 5mL of hexane to this, remove the layer of hexane and repeat this procedure one more time. Place 5mL of water layer obtained by hydrolysis in test tube and add excess amount of powdered calcium hydroxide. Then heat in water bath for 5 min and shake them to mix well. Cool down and filter. Place 1 drop of filtrate in small test tube and add 0.05g of potassium hydrogen sulfate. Put filter paper soaked with 1:1 mixture of sodium nitroprusside solution and 20% piperidine on the mouth of test tube and heat with a burner. The color of filter paper change into blue. When sodium hydroxide test solution is added again, the color of filter paper change into light red.

Purity

- (1) Lead : When 5.0 g of Ammonium phosphatides is tested by Atomic Absorption Spectrophotometry or Inductively Coupled Plasma Emission Spectroscopy, its content should not be more than 2.0ppm.
- (2) Arsenic : It should be no more than 4.0 ppm tested by Arsenic Limit Test.
- (3) Mercury : When Ammonium phosphatides is tested by Mercury Limit Test, its content should not be more than 1.0 ppm.
- (4) Cadmium : When 5.0 g of Ammonium phosphatides is tested by Atomic Absorption Spectrophotometry or Inductively Coupled Plasma Emission Spectroscopy, its content should not be

more than 1.0ppm.

(5) Insoluble petroleum ether : 10.0g of Ammonium phosphatides, accurately weighed, are transferred into a 250mL-Erlenmeyer flask with a stopper. Add 100mL of petroleum ether and shake to dissolve well. This solution is dried for 1hour at 105°C and filtered through a crucible type glass filter that is previously weighed. The flask is washed twice with 25mL of petroleum ether and all the washing solution are filtered through a glass filter. The glass filter which have the remaining insoluble substance is dried for for 1hour at 105±2°C. Allow to cool in a desiccator, and accurately weigh the amount of insoluble substance. It should not be more than 2.5%.

Assay (1) Phosphorous : Weigh accurately 1.5~1.6g of ammonium phosphatide into a small glass capsule and transfer to a 300mL flask for decomposition. Add 5mL of sulfuric acid and 10mL of nitric acid. Heat the flask gently at the beginning with shaking, then heat up gradually. After cooling, add nitric acid and heat once more until the solution have clear yellow color. Cool and add 5mL of 60% perchloric acid and oxidize until white fume generate in the flask. After cooling down again, add 5mL of water and continue to heat until white fume go out. Cool again, transfer to a 500mL-mess flask which is filled with water(Test solution). On the other hand, dissolve 3.8346g of potassium phosphate monobasic, priory dried at 110°C and accurately weighed in water. Dilute to 1000mL with water and 50mL of this solution is diluted to 500mL with water again(Standard solution). Mix 25mL of Test solution and 25mL of the vanadate-molybdate reagent, and dilute to 100mL with water. After set-aside for 10 minutes, measure absorbance of the solution at a wavelength of 420nm with 1cm path length. A reference solution is prepared by the same procedure with solution used equivalent acid instead of Test solution. Separately, with 25mL, 27.5mL, 30mL of potassium phosphate monobasic standard solution, same procedure is followed to measure absorbances, from which a calibration curve is prepared. From the calibration curve and the absorbance of test solution, the content of Phosphorous in sample is obtained.

$$\text{The content of phosphorous(\%)} = C \times \frac{0.00873}{W} \times 100$$

C : Weight of phosphorus pentoxide(P₂O₅) in 25mL of Test solution (mg)

W : Weight of the sample (g)

Test solution

Vanadate-molybdate reagent : Each 20g of ammonium molybedate and 1g of ammonium vanadate is dissolved in water. Transfer the two solution to 1000mL-mess flask and then add 140mL of nitric acid. Dilute the solution to 1000mL with water.

(2) Ammoniacal nitrogen : Accurately weigh 0.2g of ammonium phosphatide into a small glass bottle. Test it according to the Semi-micro Kjeldahl method in Nitrogen determination.

Ammonium Sulfate

Chemical Formula: $(\text{NH}_4)_2\text{SO}_4$

INS No.: 517

Molecular Weight: 132.14

CAS No.: 7783-20-2

Compositional Specifications of Ammonium Sulfate

Content Ammonium Sulfate, when calculated on the dried basis, should contain not less than 99.0% of ammonium sulfate $[(\text{NH}_4)_2\text{SO}_4]$.

Description Ammonium Sulfate occurs as colorless crystals or white lumps.

Identification Ammonium Sulfate responds to the tests for Ammonium Salt and Sulfate in Identification.

Purity (1) Clarity and Color of Solution : When 1 g of Ammonium Sulfate is dissolved in 20 mL of water, the solution should be colorless and should not be more than almost clear.

(2) Arsenic : It should be no more than 4.0 ppm tested by Arsenic Limit Test.

(3) Lead : Ammonium Sulfate is precisely weighed and is tested by purity (2) for 「Sodium Metaphosphate」(not more than 5.0 ppm).

(4) Selenium : 0.2 g of Ammonium Sulfate is precisely weighed and is tested by purity (6) for 「Sulfuric acid」(not more than 30 ppm).

Loss on Drying When Ammonium Sulfate is dried for 3 hours at 130°C the weight loss should not be more than 1%.

Residue on Ignition When thermogravimetric analysis is done with Ammonium Sulfate, the residue should not be more than 0.25%.

Assay Accurately weigh about 3 g of Ammonium Sulfate, and dissolve in water to make exactly 250 mL. Take 25 mL of this solution, add 10 mL of sodium hydroxide solution (2→5), and immediately equip with a distilling apparatus equipped with a condenser and connected to a receiver containing 40 mL of 0.2 N sulfuric acid, exactly measured. Heat to distill ammonia into sulfuric acid, and titrate the excess sulfuric acid with 0.2 N sodium hydroxide (indicator : 3 drops of methyl red solution).

1 mL of 0.2 N sulfuric acid = 13.22 mg of $(\text{NH}_4)_2\text{SO}_4$

α-Amylase

Definition There are α-Amylase(nonbacterial) and α-Amylase(bacterial). And each definitions are as follows.

α-Amylase(nonbacterial): is an enzyme obtained from cultures of *Aspergillus niger* and its variety, *Aspergillus oryzae* and its variety, and *Rhizopus oryzae* and its variety, *Aspergillus niger* containing the gene of alpha-amylase from *Rhizomucor pusillus* and malts.

α-Amylase(bacterial): is an enzyme obtained from cultures of *Bacillus subtilis* and its variety, *Bacillus licheriformis* and its variety, *Bacillus stearothermophilus*, and *Bacillus licheriformis* containing the gene of alpha-amylase from *Bacillus stearothermophilus*. It is called α-Amylase(nonbacterial) and α-Amylase(bacterial), respectively. Dilutant or stabilizer can be added for the purpose of activity adjustment and quality preservation.

A. α-Amylase(nonbacterial)

Compositional Specifications of α-Amylase, Nonbacterial

Description α-Amylase, Nonbacterial (DU) is white ~ dark brown powder, particle, paste or colorless ~ dark brown liquid.

Identification When α-Amylase, Nonbacterial (DU) is proceeded as directed under Activity Test, it should have the activity as α-Amylase, Nonbacterial (DU).

Purity (1) Arsenic : It should be no more than 4.0 ppm tested by Arsenic Limit Test.

(2) Lead : When 5.0 g of α-Amylase is tested by Atomic Absorption Spectrophotometry or Inductively Coupled Plasma Emission Spectroscopy, its content should not be more than 5.0 ppm.

(3) Coliform Group : α-Amylase, Nonbacterial is tested by Microbe Test Methods for Coliform Group in General Test Methods「Standards and Specifications for Foods」. It should not be more than 30 cfu per 1 g of this product.

(4) Salmonella : α-Amylase, Nonbacterial (DU) is tested by Microbe Test Methods for Salmonella in General Test Methods 「Standards and Specifications for Foods」. It should be negative (-).

(5) E. Coli : When α-Amylase(nonbacterial) is tested by Microbe Test Methods for E. Coli in General Test Method 「Standards and Specifications for Foods」, it should be negative (-)

Activity Test (Activity)

•Analysis Principle : Activity test is based on the time taken to reach standard degree of hydrolysis of starch solution with a certain concentration at $30 \pm 0.1^{\circ}\text{C}$. The degree of hydrolysis is measured by comparing iodine color of the hydrolyzed products with color standard.

•Preparation of Test Solution : Test Solution is prepared so that the end point of 5 mL of the finally diluted solution is reached in 10 ~ 30 minutes under the test conditions. In case of malt, 25.0 g of fine ground powder is weighed into a 1,000 mL Erlenmeyer flask, where 500 mL of 0.5% sodium chloride solution is added. The mixture is leached for 2.5 hours at $30 \pm 0.2^{\circ}\text{C}$ while stirring once in every 20 minutes (caution : The flask should not be turned upside down. Care must be minimized the amount of the content left on the inner wall.). After leaching, the mixture is filtered through a 32 cm Whatman No.1 filter paper using a 20 cm diameter funnel. First 50 mL of the filtrate is combined to sample solution

and re-filtered through the same filter paper. Filtration is stopped in 3 hours since the point when the sample is mixed in sodium chloride solution. 20.0 mL of the filtrate is diluted to 100 mL with 0.5% sodium chloride solution (Test Solution).

Test Procedure : 5 mL of iodine solution is added to each of a set of 20 test tubes (13×100 mm), which are maintained at $30 \pm 0.1^\circ\text{C}$ in a water bath. 20 mL of substrate solution and 5 mL of 0.5% sodium chloride solution (previously maintained for 20 minutes in a water bath) are mixed in a 50 mL Erlenmeyer flask, which is then kept in a water bath. Upon starting the test, 5 mL of the Test Solution is added to the flask in the water bath. In 10 minutes, 1 mL of the reaction mixture in the 50 mL Erlenmeyer flask is taken and added to the test tube with iodine solution, which is well shaken and immediately compared to the color standard obtained from a comparator. A tube filled with water is used behind the comparator plate. (note : Care must be taken so that the tip of the pipette, which draws the reaction mixture, does not touch the iodine solution. If iodine solution is mixed with reaction mixture, the reaction may be affected.). By the same method, a comparison test is repeated at a same interval until the color of the Test Solution becomes the same as the color standard. Time at each pipetting is recorded.

Reference : If a previous test color is deeper and a subsequent (in a 30 second interval) test color is lighter than the color standard, the end point is obtained by adding 15 seconds to the time for the color nearer to the color standard. Comparator tube (13 mm) is shaken after each observation. Difference in color judgment due to personal difference can be minimized by using a prism attachment and observing at a distance of 6 ~ 10" . Activity of an enzyme can be calculated by the following equation.

$$\text{DU}(\text{solution}) = \frac{24}{W \times T}$$

$$\text{DU (as a dried form)} = \text{DU}(\text{solution}) \times \frac{100}{100 - M}$$

W : Amount of enzyme in 5 mL of Test Solution (g)

T : Dextrinization time (minutes)

24 : Weight of starch substrate (0.4 g) multiplied by 60 minutes

M : Water content of sample (%)

Definition of Activity : 1 α -Amylase dextrinizing unit (DU) is an amount of enzyme that dextrinizes soluble starch at a rate of 1 g per hour at 30°C under the presence of sufficient amount of β -Amylase.

Apparatus

-Color standard for comparison : α -amylase color plate is used. Or 25 g of cobalt chloride ($\text{CoCl}_2 \cdot 6\text{H}_2\text{O}$) and 3.84 g of potassium bichromate is dissolved in 0.01 N hydrochloric acid and is made 100 mL. (this

is stable for a long period of time when is capped.).

- Comparator : Standard Hellige comparator or Pocket comparator is used along with prism attachment. A milky light (100 W) should be shone at a 6 inch distance from the back of the milky colored glass of the comparator. The light should be positioned so that it won't be shone directly on observer's eyes.
- Comparator Tubes : An angled tube with 13 mm path length or its equivalent should be used.

Solutions

- Acetate Buffer Solution (pH 4.8) : 164 g of anhydrous sodium acetate is dissolved in 500 mL of water and 120 mL of glacial acetic acid is added. pH of the solution is adjusted to 4.8 with glacial acetic acid. The total volume is brought up to 1,000 mL with water and well mixed.
- β -Amylase Solution : 250 mg of β -Amylase (free of α -Amylase) with 2,000 DP°C is dissolved in 5 mL of water (note : Enzyme should be kept by refrigeration. Before opening the cap, it should be warmed to room temperature to prevent condensation of moisture.).
- Starch : Soluble starch (Lintner) or its equivalent is used. Before using a new lot, it should be confirmed that the quality is the same as the previous one. A new lot with a difference of diastatic power $\pm 3^\circ\text{C}$ or higher cannot be used.
- Substrate Solution : 10.0 g of starch (as a dried form) is dispersed in 100 mL of cold water, where 300 mL of boiling water is slowly added with stirring. After boiling for 1 ~ 2 minutes, it is cooled and transferred into a 500 mL volumetric flask. 25 mL of acetate buffer solution is added to the flask, where all of the β -Amylase solution is added. It is then saturated with toluene and diluted to 500 mL with water. The resultant solution is allowed to stand for 18 ~ 72 hours at $30 \pm 2^\circ\text{C}$ and then used.
- Iodine stock solution : 5.5 g of iodine and 11.0 g of potassium iodide are dissolved in 200 mL of water, which is then diluted to 250 mL with water. It is kept in a dark place. It should be freshly prepared in every 30 days.
- Iodine Solution : 20 g of potassium iodide is dissolved in 300 mL of water and 2.0 mL of iodine stock solution is added. The total volume of the solution is brought up to 500 mL with water.

Storage Standard of α -Amylase, Nonbacterial(DU)

α -Amylase, Nonbacterial (DU) is stored sealing tightly in a cold dark place.

B. α -Amylase(bacterial)

Compositional Specifications of α -Amylase, Bacterial

Description α -Amylase, Bacterial (BAU) is white ~ dark brown powder, particle, paste or colorless ~ dark brown liquid.

Identification When α -Amylase, Bacterial (BAU) is proceeded as directed under Activity Test, it should have the activity as α -Amylase, Bacterial (BAU).

Purity (1) Arsenic : It should be no more than 4.0 ppm tested by Arsenic Limit Test.

(2) Lead : When 5.0 g of α -Amylase is tested by Atomic Absorption Spectrophotometry or Inductively Coupled Plasma Emission Spectroscopy, its content should not be more than 5.0 ppm.

(3) Coliform Group : α -Amylase, Nonbacterial is tested by Microbe Test Methods for Coliform Group in General Test Methods「Standards and Specifications for Foods」. It should not be more than 30 cfu per 1 g of this product.

(4) Salmonella : α -Amylase, Nonbacterial (DU) is tested by Microbe Test Methods for Salmonella in General Test Methods 「Standards and Specifications for Foods」. It should be negative (-).

(5) E. Coli : When α -Amylase(nonbacterial) is tested by Microbe Test Methods for E. Coli in General Test Method 「Standards and Specifications for Foods」, it should be negative (-).

Activity Test (Activity)

- Analysis Principle : Activity test is based on the time taken to reach standard degree of hydrolysis of starch solution with a certain concentration at $30 \pm 0.1^\circ\text{C}$. The degree of hydrolysis is measured by comparing iodine color of the hydrolyzed products with color standard.
- Preparation of Test Solution : Test Solution is prepared so that the end point of 10 mL of the finally diluted solution is reached in 15 ~ 35 minutes under the test conditions.
- Test Procedure : It is tested as directed under the Test Procedure for α -Amylase, Nonbacterial (DU). However, 10 mL of Test Solution is added instead of sodium chloride solution.

Activity of an enzyme is calculated by the following equation.

$$\text{BAU/g} = 40F/T$$

F : Dilution factor (total amount of dilution/amount of sample(g))

T : Dextrinization time (minutes)

40 : A factor (400/10) that is calculated by dividing 400 mg (amount of starch in 20 mL of 2% substrate solution) with 10 mL (amount of Test Solution used).

- Definition of Activity : 1 Bacterial amylase unit(BAU) corresponds to an amount of enzyme that dextrinizes 1 mg of starch per minute under the conditions above.

Apparatus

Color standard for comparison, Comparator, and Comparator Tubes are the same as in α -amylase, Nonbacterial(DU). However, daylight or daylight type fluorescent light is used as a light source.

Solutions

- Phosphate Buffer Solution (pH 6.6)

Solution A : 9.1 g of potassium phosphate, monobasic (anhydrous) is dissolved in plenty of water (total volume = 1,000 mL).

Solution B : 9.5 g of sodium phosphate, dibasic (anhydrous) is dissolved in plenty of water (total volume

= 1,000 mL).

Solution A & B are mixed at a ratio of 400 mL : 600 mL. If necessary, pH of the solution is adjusted to 6.6 with Solution A or Solution B.

◦ Iodine Solution : Prepared same as α -amylase, Nonbacterial(DU).

Starch : Prepared same as α -amylase, Nonbacterial(DU).

Substrate Solution : 10 g of starch (as a dried form) is dispersed in 100 mL of cold water, where 300 mL of boiling water is slowly added with stirring. After boiling for 1 ~ 2 minutes, it is cooled and transferred into a 500 mL volumetric flask. 10 mL of phosphate buffer solution is added to the flask and the total volume is brought up to 500 mL with water.

Storage Standard of α -Amylase, Bacterial(BAU)

α -Amylase, Bacterial (BAU) is stored sealing tightly in a cold dark place.

β-Amylase

Definition β-Amylase is an enzyme obtained from cultures of *Bacillus licheriformis* containing the gene of β-amylase from *Bacillus flexus*. Dilutant or stabilizer and etc. can be added for the purpose of titer adjustment and quality preservation.

β-amylase hydrolyze the combination of α-1,4 glucoside bond from the non-reducing end-group of starch and etc. to produce maltose.

Compositional Specifications of β-Amylase

Description β-Amylase is a white~dark brown powder, granule, paste, or colorless~dark brown liquid.

Identification It should have the activity as β-Amylase when testing by the Activity Test.

Purity (1) Arsenic : It should be no more than 4.0 ppm tested by Arsenic Limit Test.

(2) Lead : When 5.0 g of β-Amylase is tested by Atomic Absorption Spectrophotometry or Inductively Coupled Plasma Emission Spectroscopy, it should not be more than 5.0 ppm.

(3) Coliform Group : When β-Amylase is tested by Microbe Test Methods for Coliform Group of General Test Methods in 「Standards and Specifications for Foods」, it should not be more than 30 cfu per 1 g of this product.

(4) Salmonella : When β-Amylase is tested by Microbe Test Methods for Salmonella of General Test Methods in 「Standards and Specifications for Foods」, it should be negative (-).

(5) *E. Coli* : When β-Amylase is tested by Microbe Test Methods for *E. Coli* of General Test Method in 「Standards and Specifications for Foods」, it should be negative (-).

Activity Test (titer)

- Analysis Principle : This titer test is based on the hydrolysis of starch at 4.8 and 25°C for 3 minutes. The degree of hydrolysis is measured as absorbtion in the reduction of the 3,5-dinitrosalicylic acid caused by a hydrolyzed substance, maltose.
- Preparation of Test Solution : Dilute 0.5 mL of sample with water to fit within the calibration curve.
- Test Procedure : Maintain temperature of 0.5 mL test solution at 25°C for 3~4 minutes. Use 0.5 mL water as control solution. Add 0.5 mL of substrate solution, and then add 1 mL of dinitrosalic acid solution after exact 3 minutes, respectively. React in boiling water for 5 minutes. After cooling down at a ordinary temperature, add 10 mL of distilled water. Measure absorbtion at 540 nm after mixing well. Calculate the amount of maltose using calibration curve.

$$\text{Titer(Units/mg)} = \frac{M}{3 \times W}$$

M : μmol of maltose calculated by calibration curve

W : Amount(mg) of sample containing in 0.5 mL test solution

Calibration curve Preparation : After melting 180 mg maltose with 100 mL water, maintain temperature at 25°C for 4~5 minutes before using it. Dilute at least 5 concentrations to make 0.3~5 μmol per 1 mL. Take 1 mL of it and add 1 mL of dinitrosalicylic acid. After reacting it in hot water bath for 5 minutes, cool down. Add 10 mL of water, respectively and mix well. Measure absorbtion at 540 nm by using water as control solution, and prepare calibration curve by absorbtion of maltose(μmol).

Definition of titer : 1 unit is the the amount of enzyme that librate 1 μmol of maltose per minutes under the above test conditions.

Solutions

Dinitrosalicylic acid solution : Dissolve 3,5-dinitrosalicylic acid in 50 mL water, and add 30 g of sodium calcium tartrate slowly. Add 20 mL of 2N sodium hydroxide and add 100 mL of water.

Substrate solution(1% starch solution) : Mix 1 g of soluble starch with 100 mL of sodium acetate buffer(pH 4.8). Stir in hot water slowly to dissolve until the solution becomes translucent. Alllow to cool down, then dilute with 100 mL of water if necessary. Allow to stand at 25 ° C for 4~5 minutes before use.

Maltose stock solution (5 $\mu\text{mol}/\text{mL}$) :180 mg of maltose is dissolved in 100 mL of water, and the mixture is allowed to stand at 25°C for 4~5 minutes before use.

Storage Standard of β -Amylase

β -Amylase should be stored sealing tightly in a cold dark place.

α -Amylcinnamaldehyde

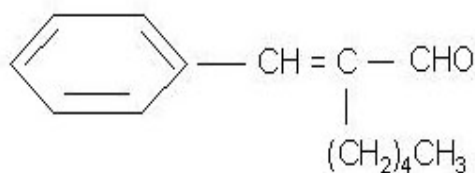

Chemical Formula: $C_{14}H_{18}O$

Molecular Weight: 202.30

Synonyms: α -Pentylcinnamaldehyde

CAS No.: 122-40-7

Compositional Specifications of α -Amylcinnamaldehyde

Content α -Amylcinnamaldehyde should contain not less than 97.0% of α -Amylcinnamaldehyde ($C_{14}H_{18}O$)

Description α -Amylcinnamaldehyde is a light yellow to yellow and transparent liquid having a characteristic odor.

Identification (1) To 1 drop of α -Amylcinnamaldehyde, add 1 mL of water shake well, add 2 drops of sodium nitroprusside solution, add 2 drops of sodium hydroxide solution (3 \rightarrow 10), and shake. A dark yellow color develops. Add 5 drops of diluted acetic acid. The color of the solution becomes lighter.
(2) Dissolve 5 mL of α -Amylcinnamaldehyde in 20 mL of ethanol. To this solution, add a solution, 1.7 g of hydroxylamine hydrochloride and 1.3 g of sodium hydroxide are dissolved in 5 mL of water, shake well, and allow to stand for about 90 minutes. White crystals are deposited. Collect the crystals by filtration, and recrystallize using ethanol as the solvent. The melting point is approximately 75°C.

Purity (1) Specific Gravity : Specific gravity should be within a range of 0.963~0.968.

(2) Refractive Index : Refractive Index n_D^{20} should be within a range of 1.554~1.559.

(3) Clarity and Color of Solution Clear : When 1 mL of α -Amylcinnamaldehyde is dissolved in 4.5 mL of 80% alcohol, the solution should be clear.

(4) Acid Value : Acid value of α -Amylcinnamaldehyde is tested by Acid Value in Flavoring Substance Test. It should not be more than 5.

Residue on Ignition Residue after ignition should not be more than 0.05%.

Assay Accurately weigh about 1.5 g of α -Amylcinnamaldehyde, and proceed as directed under Method 2 in Aldehyde and Ketone Content in Flavoring Substances Tests. In the procedure, heat the mixture for 30 minutes.

1 mL of 0.5 N hydrochloric acid = 101.1 mg of $C_{14}H_{18}O$

Anisaldehyde



Chemical Formula: $C_8H_8O_2$

Molecular Weight: 136.15

Synonyms: 4-Methoxybenzaldehyde; Anisic aldehyde

CAS No.: 123-11-5

Compositional Specifications of Anisaldehyde

Content Anisaldehyde should contain no less than 97.0% of anisaldehyde ($C_8H_8O_2$).

Description Anisaldehyde is a colorless to light yellow and transparent liquid having a characteristic odor.

Identification To 5 drops of Anisaldehyde, add 1 mL of sodium hydrogen sulfite solution, and shake. The mixture forms crystalline lumps. Add 7 mL of water, and shake. The crystalline lumps dissolve almost clearly.

Purity (1) Specific Gravity : Specific gravity should be within a range of 1.119 ~ 1.123.

(2) Refractive Index : Refractive Index n_D^{20} should be within a range of 1.571 ~ 1.574.

(3) Clarity and Color of Solution : When 1 mL of Anisaldehyde is dissolved in 7 mL of 50% alcohol, the solution should be clear.

(4) Acid value : Acid value of Anisaldehyde is tested by Acid Value in Flavoring Substance Test. It should not be more than 6.

Assay Accurately weigh about 0.8 g of Anisaldehyde, and proceed as directed under Method 2 in Aldehyde and Ketone Content in flavoring Substances Tests. In the procedure, allow the mixture to stand for 15 minutes.

1 mL of 0.5 N hydrochloric acid = 68.08 mg of $C_8H_8O_2$

Annatto Extract

Synonyms: L. Orange; Orlean

INS No.: 160b(i), 160b(ii)

CAS No.: 1393-63-1

Definition There are types, oil soluble pigment and water dispersible pigment. Oil soluble pigment is obtained by extracting seed skin of *Bixa orellana* Linné. with oil and fat or organic solvents (extracting solvent for oleoresin spices). Its major component is bixin ($C_{25}H_{30}O_4 = 394.52$) of carotinoids. Water dispersible pigment is obtained by dispersing fine pigments contained in seed skins of *Bixa orellana* L.in with water or propylene glycol. It can also be obtained by hydrolysing bixin under pressure and heating. Its major component is bixin or norbixin ($C_{24}H_{30}O_4 = 380.49$) of carotinoids. Dilutant, stabilizer, or solvent can be added for the purpose of color value adjustment and quality preservation.

Compositional Specifications of Annatto Extract

Content Color value ($E_{1cm}^{10\%}$) of Annatto Extract should not be less than the indicated value.

Description Annatto Extract is reddish brown ~ brown liquid, lump, powder or paste with a slight characteristic odor.

Identification (1) Test Solution obtained in Color Value section of Annatto Extract shows orange yellow color and a absorbance maximum at about 500 nm and 470 nm.

Purity (1) Arsenic : It should be no more than 4.0 ppm tested by Arsenic Limit Test.

(2) Lead : When 5.0 g of Annatto Extract is tested by Atomic Absorption Spectrophotometry or Inductively Coupled Plasma Emission Spectroscopy, its content should not be more than 2.0 ppm.

(3) Cadmium : When 5.0 g of Annatto Extract is tested by Atomic Absorption Spectrophotometry or Inductively Coupled Plasma Emission Spectroscopy, its content should not be more than 1.0 ppm.

(4) Mercury : When 0.1 g of Annatto Extract is tested by Mercury Test Method, its content should not be more than 1.0 ppm.

(5) Residual Solvents : When Annatto Extract is tested by Purity (5) for Paprika Extract Pigments, the content of residual solvents should be.

Methylene chloride, trichloroethylene	Not more than 30ppm (individual or sum if used together)
Acetone	Not more than 30ppm
Isopropyl alcohol	Not more than 50ppm
Methyl alcohol	Not more than 50ppm
Hexane	Not more than 25ppm

Assay (Color Value) Annatto Extract is precisely weighed to showed absorbance within 0.3~0.7. It is dissolved in dimethylformamide for oil soluble pigment and in 0.1 N sodium hydroxide solution for water dispersible pigment and make 100 mL, respectively. A mixture of water, dimethylformamide, and acetic acid (50:50:1) is added to 5 mL of this solution and diluted to 100 mL with a mixture of water, dimethylformamide, and acetic acid (50:50:1), test solution. Using a mixture of water, dimethylformamide, and acetic acid (50:50:1) as a reference, a absorption maximum A of the Test Solution is measured at about 470 nm with 1 cm cell. Color value is obtained using the following equation.

$$\text{Color Value (E}_{1\text{cm}}^{1\%}) = \frac{A \times 200}{\text{weight of the sample(g)}}$$

Annatto, Water-soluble

Synonyms: L. orange; Orlean

INS No.: 160b(ii)

CAS No.: 33261-80-2(K염)

33261-81-3(Na염)

Definition Annatto, Water-soluble is prepared from the red precipitate of the seed of the annatto tree (*Bixa orellana* L (Bixaceae)) by hydrolysis. The coloring principle is the potassium or sodium salt of the norbixin.

Compositional Specifications of Annatto, Water-soluble

Content Annatto, Water-soluble should contain within a range of 100.0 ~ 125.0% of the declared amount of norbixin ($C_{24}H_{28}O_4=380.49$)

Description Annatto, Water-soluble occurs as red-brown to brown powder, lumps, liquid, or pasty substances, having a slight, characteristic odor.

Identification (1) Dilute Annatto, Water-soluble in 0.1 N sodium hydroxide solution until the color of the solution becomes almost the same as that of potassium dichromate solution (1→1,000). Add 2 mL of diluted sulfuric acid to 50 mL of this solution, mix, add 10 mL of benzene, and extract by shaking well. Wash this extract three times with 5 mL of water each time. Perform the following tests, using this solution as the test solution.

(A) Extract 5 mL of the test solution, using 5 mL of 0.01 N sodium hydroxide solution each time until the sodium hydroxide solution is not colored. Combine the extracts and add 0.01 N sodium hydroxide solution to make 50 mL. The solution exhibits absorbance maxima at wavelengths of 454 ± 2 nm and 482 ± 2 nm.

(B) Transfer a suspension of aluminum for vitamin A determination in benzene into a glass tube to make an alumina layer about 5 cm high, and keep the alumina layer constantly immersed in benzene. Place small pieces of filter paper on the top of the alumina layer, pour 10 mL of benzene and adjust the rate of the flow so that the benzene drops at a rate of about 30 drops per minute. When the level of the benzene becomes about 1 cm above the upper end of the alumina layer, put 3 mL of the test solution into the column. Add 5 mL of chloroform while the level of the test solution remains slightly in the upper part of the alumina layer. In the same manner, add twice 5 mL of chloroform each time, and add 2 mL of antimony trichloride solution. The yellow-orange color of the adsorption band in the upper part of the alumina layer slowly changes to blue-green.

(2) To 1 g of Annatto, Water-soluble, add 50 mL of water, shake, and filter. Add 2 mL of diluted hydrochloric acid to the filtrate. A red-brown to yellow-brown precipitate is formed.

Purity (1) Absorption Ratio : Proceed as directed under (A) in Identification (1). The absorbance ratio between the maximum absorption band at 482 ± 2 nm and 454 ± 2 nm should be within a range of

1.18 ± 0.07.

- (2) Arsenic : It should be no more than 4.0 ppm tested by Arsenic Limit Test.
- (3) Lead : When 5.0 g of Annatto, Water-soluble is tested by Atomic Absorption Spectrophotometry or Inductively Coupled Plasma Emission Spectroscopy, its content should not be more than 2.0 ppm.
- (4) Cadmium : When 5.0g of Annatto, Water-soluble is tested by Atomic Absorption Spectrophotometry or Inductively Coupled Plasma Emission Spectroscopy, its content should not be more than 1.0 ppm.
- (5) Mercury : When Annatto, Water-soluble is tested by Mercury Limit Test, its content should not be more than 1.0 ppm.
- (6) Free Alkali : To 10 g of Annatto, Water-soluble, add 100 mL of water and 8 mL of 1 N hydrochloric acid, shake, and mix it. Allow the solution to stand for 30 minutes and filter it. The pH of the solution should be not more than 7.0.

Assay Accurately weigh 0.1 ~ 1 g of Annatto, Water-soluble, add 0.01 N sodium hydroxide to make exactly 100 mL, and mix thoroughly. Take 1 mL of this solution, transfer into a separating funnel, and add 10 mL of sodium chloride (1→10) and water to make 50 mL. Add 2 mL of diluted sulfuric acid, and mix thoroughly. Repeat the extraction procedure, using 10 mL of benzene each time, until the extract is not colored. Combine the extracts, wash three times with 5 mL of water each time, allow to stand for a while, and completely remove the water layer. Transfer the extract into another separating funnel, and wash the previous separating funnel three times with 2 mL of benzene each time. Combine the washings with the benzene extract. Add an equal amount of petroleum benzene to the extract, mix, repeat the extraction procedure, using 5 mL of 0.01 N sodium hydroxide each time, until the 0.01 N sodium hydroxide is not colored, combine the extracts, and add 0.01 N sodium hydroxide to make exactly 100 mL. Measure absorbance A of this solution at a wavelength of 454 nm, and calculate the content of norbixin by the following formula

$$\text{Content(\%)} = \frac{A}{3,473} \times \frac{100,000}{\text{weight of the sample(mg)}} \times 100$$

β -Apo-8'-Carotenal

Chemical Formula: $C_{30}H_{40}O$

Molecular Weight: 416.65

Synonyms: CI Food orange 6

INS No.: 160e

CAS No.: 1107-26-2

Compositional Specifications of β -Apo-8'-Carotenal

Content β -Apo-8'-Carotenal should contain not less than 96.0% β -Apo-8'-Carotenal($C_{30}H_{40}O$).

Description β -Apo-8'-Carotenal is deep violet crystal or crystalline powder with metallic gloss.

Identification (1) 40 mg of β -Apo-8'-Carotenal, accurately weighed, is transferred into a 100 mL volumetric flask. It is then dissolved in 10 mL of acid free chloroform and cyclohexane is added to bring the total volume to 100 mL. 2 mL of this solution is transferred into a 50 mL volumetric flask, which is then filled with cyclohexane (solution A). 5 mL of the solution is transferred into 50 mL volumetric flask, which is then filled with cyclohexane (solution B). Absorption of solution B is measured is at 460 nm and 488 nm. Absorption ratio $[A_{488}/A_{460}]$ should be within a range of 0.77~0.85.
(2) Absorption of solution B, as prepared following procedure (1), is measured is at 460 nm and absorption of solution A is measured at 332 nm. Absorption ratio $[A_{332}/10 \times A_{460}]$ should be within a range of 0.063~0.075.
(3) When dissolve 0.1 g of β -Apo-8'-Carotenal in 10 mL of acetone, and add 5% sodium nitrite solution and 1 N sulfuric acid, its color disappears.
(4) When dissolve 0.1 g of β -Apo-8'-Carotenal in 10 mL of chloroform, and add antimony trichloride solution, it turns blue.

Purity (1) Arsenic : It should be no more than 4.0 ppm tested by Arsenic Limit Test.

(2) Lead : When 5.0 g of β -Apo-8'-Carotenal is tested by Atomic Absorption Spectrophotometry or Inductively Coupled Plasma Emission Spectroscopy, its content should not be more than 2.0 ppm.

(3) Cadmium : When 5.0 g of β -Apo-8'-Carotenal is tested by Atomic Absorption Spectrophotometry or Inductively Coupled Plasma Emission Spectroscopy, its content should not be more than 1.0 ppm.

(4) Mercury : When β -Apo-8'-Carotenal is tested by Mercury Limit Test, its content should not be more than 1.0 ppm.

(5) Accessory Pigments : 0.25 mm thin layer silica gel plate is wetted by immersing it in 3% potassium hydroxide solution in methyl alcohol. After drying for 5 minutes in air, the plate is activated by heating at 110°C for 1 hour, which is then kept in a desiccator (calcium chloride). 80 mg of β -Apo-8'-Carotenal is dissolved in 100 mL of chloroform. 400 μ l of this solution is spotted at 2cm from the bottom of thin

layer plate, which is then developed to approximately 10 cm in a bath saturated developing with n-cyclohexane, chloroform, and ethyl acetate (70 : 20 : 10). This is to be carried out in a light shielded hermetic container. The thin layer plate is dried at room temperature and the spot is marked. Thin layer of developed β -apo-8'-carotenal is scraped off into a 100 mL centrifuge tube and 40 mL of chloroform is added, which is then shaken for 10 minutes and centrifuged for 5 minutes (Solution A₁). Thin layer of other developed carotinoids is scraped off and 20 mL of chloroform is added, which is then shaken for 10 minutes and centrifuged for 5 minutes (Solution A₂). Solution A₃ is prepared by taking 10 mL of A₁ and bringing the total volume to 50 mL with chloroform. Using chloroform as a reference, optical absorption of A₂ and A₃ is measured at 474 nm using 1 cm path length. The content of other carotinoids, as obtained by the equation below, should not be more than 3%.

$$\text{Content of other carotinoids(\%)} = \frac{A_2 \times 10}{A_3} \times 100$$

(6) Melting Point : Melting point of β -Apo-8'-Carotenal should be within a range of 136~142°C.

Residue on Ignition When thermogravimetric analysis is done with 2 g of β -Apo-8'-Carotenal, the amount of residue should not be more than 0.1%.

Loss on Drying When β -Apo-8'-Carotenal is dried in a vacuum desiccator (sulfuric acid) for 4 hours , the loss should not be more than 0.2%.

Assay 40 mg of β -Apo-8'-Carotenal is accurately weighed into a 100 mL mess flask and dissolved in 10 mL acid-free chloroform, which is then filled with cyclohexane. 2 mL of this solution is then transferred into a 50 mL mess flask, which is then filled with cyclohexane. Again, 5 mL of this solution is transferred into a 50 mL mess flask, which is filled with cyclohexane, Test Solution. Using cyclohexane as a reference, absorption of the resulting test solution is measured at 460 nm with 1cm path length. The content of β -apo-8'-carotenal is obtained using the following equation.

$$\text{Content of } \beta\text{-apo-8'-carotenal(\%)} = \frac{25,000 \times A}{264}$$

A : Absorption of test solution

264 : Absorption of pure β -apo-8'-carotenal ($E_{1\text{cm}}^{1\%}$)

Arabic Gum

INS No.: 414

Synonyms: Acacia; Acacia gum

CAS No.: 9000-01-5

Definition Arabic Gum is obtained from drying the secretion of acacia senegal (*Acacia senegal* WILLDENOW) of leguminosae or its other variety from the same genus. Or it can be obtained by de-salting the same. The major component is polysaccharides.

Compositional Specifications of Arabic Gum

Description Arabic Gum is white ~ light yellow powder, granules or light yellow ~ brown lump and odorless.

Identification 1 g of Arabic Gum is dissolved in 50 mL of cold water. Upon adding 0.2 mL of dilute lead nitrous acid solution to 10 mL of this solution, it forms agglomerates or white precipitates immediately.

Purity (1) Arsenic : It should be no more than 4.0 ppm tested by Arsenic Limit Test.

(2) Lead : When 5.0 g of Arabic Gum is tested by Atomic Absorption Spectrophotometry or Inductively Coupled Plasma Emission Spectroscopy, its content should not be more than 2.0 ppm.

(3) Cadmium : When 5.0 g of Arabic Gum is tested by Atomic Absorption Spectrophotometry or Inductively Coupled Plasma Emission Spectroscopy, its content should not be more than 1.0 ppm.

(4) Mercury : When 0.1 g of Arabic Gum is tested as directed under Mercury Test Method, its content should not be more than 1.0 ppm.

(5) Acid Insoluble Ash : When Arabic Gum is tested for Ash by General Test Methods, it should not be more than 0.5%.

(6) Starch and Dextrin : 1 g of Arabic Gum is dissolved in 50 mL of water by boiling, which is then cooled. When a few drops of iodine solution are added, it should not change blue or red.

(7) Tannin Containing Gums : 1 g of Arabic Gum is dissolved in 50 mL of water. When 0.1 mL of ferric chloride TS is added to 10 mL of this solution, black matter or precipitates should not form.

(8) Water Insoluble substances : 5 g of Arabic Gum is placed into an Erlenmeyer flask containing about 100 mL of water. 10 mL of dilute hydrochloric acid is added to the flask, which is then gently boiled and filtered through a glass filter, previously made constant weight. The residue is washed with plenty of hot water. The residue is dried for 2 hours at 105°C. The content of water insoluble substances should not be more than 1%.

(9) E. Coli : When Arabic Gum is tested by Microbe Test Methods for E. Coli in General Test Method 「Standards and Specifications for Foods」, it should be negative (-).

(10) Salmonella : When Arabic Gum is tested by Microbe Test Methods for Salmonella in General Test

Method 「Standards and Specifications for Foods」, it should be negative (-).

Ash When Arabic Gum is tested for ash, it should not be more than 4%.

Loss on Drying When 1 g (uncrushed sample should be well mixed prior to weighing and passed through a standard mesh screen No.40) of Arabic Gum is dried for 5 hours at 105°C, the weight loss should not be more than 15%.

Arabinogalactan

INS No.: 409

Synonyms: Larch fiber; Larch gum

CAS No.: 9036-66-2

Definition Arabino Galactan is a polysaccharide obtained by extracting roots or stems of Larix occidentalis NUTT. of pinaceae with water.

Compositional Specifications of Arabino Galactan

Description Arabino Galactan is white ~ pale yellowish brown powder with a slight characteristic scent.

Identification (1) When 6 g of Arabino Galactan is gently mixed and stirred in 10 mL of water, it readily dissolves and turns into a slightly viscous liquid.

(2) Add 5 mL of water to 5 mL of the solution from (1), and then add 5 mL of sodium borate solution (1→20). When Cetylpyridinium Chloride solution (1→20) is drop-wise added to the resulting solution, white precipitates are formed.

Purity (1) Arsenic : It should be no more than 4.0 ppm tested by Arsenic Limit Test.

(2) Lead : When 5.0 g of Arabino Galactan is tested by Atomic Absorption Spectrophotometry or Inductively Coupled Plasma Emission Spectroscopy, its content should not be more than 10.0 ppm.

(3) Total Viable Aerobic Count : When Arabino Galactan is tested by Microbe Test Methods for Total Viable Aerobic Count (Number of General Germs) in General Test Method in 「Standards and Specifications for Foods」, it should not be more than 10,000 per 1 g

(4) E. Coli : When Arabino Galactan is tested by Microbe Test Methods for E. Coli in General Test Method 「Standards and Specifications for Foods」, it should be negative (-).

Ash When Arabino Galactan tested by Ash and Acid-Insoluble Ash Limit, the amount of ash should be 4%.

Loss on Drying When Arabino Galactan is dried for 5 hours at 105°C, the weight loss should not be more than 12%.

L-Arginine

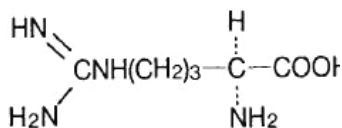

Chemical Formula: C₆H₁₄N₄O₂

Molecular Weight: 174.20

Synonyms: L-2-Amino-5-guanidinovaleric acid

CAS No.: 74-79-3

Compositional Specifications of L-Arginine

Content L-Arginine, when calculated on the dried basis, should contain within a range of 98.0~102.0% of L-arginine (C₆H₁₄N₄O₂).

Description L-Arginine is white crystallite or crystalline powder with unique scent and taste.

Identification (1) 1 mL of ninhydrine solution (1→50) is added to 5 mL aqueous solution of L-Arginine (1→1,000). Upon heating for 3 minutes in a water bath, this solution turns blue-purple color.

(2) Aqueous solution of L-Arginine is alkaline.

Purity (1) Clarity and Color of Solution : When 1 g of L-Arginine is dissolved in 20 mL of water, the solution should be colorless and clear.

(2) pH : pH of L-Arginine solution (1→20) should be within a range of 10.5~12.5.

(3) Specific Rotation : Approximately 8 g of L-Arginine is accurately weighed, which is dissolved in 6 N hydrochloric acid so that the total volume becomes 100 mL. Optical rotation of the solution is measured. When it is translated to dried material, $[\alpha]_D^{20} = +25.0 \sim +27.9^\circ$

(4) Chlorides : When 0.07 g of L-Arginine is tested by Chloride Limit Test, the content should not be more than the amount that corresponds to 0.2 mL of 0.01 N hydrochloric acid.

(5) Arsenic : It should be no more than 4.0 ppm tested by Arsenic Limit Test.

(6) Lead : When 5.0 g of L-Arginine is tested by Atomic Absorption Spectrophotometry or Inductively Coupled Plasma Emission Spectroscopy, its content should not be more than 5.0 ppm.

Loss on Drying When L-Arginine is dried for 3 hours at 105°C, the weight loss should not be more than 1.0%.

Residue on Ignition Residue after ignition should not be more than 0.2%.

Assay Approximately 0.2 g is accurately weighed and dissolved in 3 mL of formic acid, where 50 mL of glacial acetic acid (for non-aqueous titration) is added. This solution is titrated with 0.1 N perchloric acid (indicator : 1 mL of crystal violet ·glacial acetic acid). At the end point, solution turns from violet to blue, then to green. Separately, a blank experiment is done following the same procedure.

1 mL of 0.1 N perchloric acid solution = 8.710 mg $C_6H_{14}N_4O_2$

L-Ascorbyl Palmitate



Chemical Formula: $C_{22}H_{38}O_7$

Molecular Weight: 414.54

INS No.: 304

Synonyms: Ascorbyl palmitate; Vitamin C
palmitate

CAS No.: 137-66-6

Compositional Specifications of L-Ascorbyl Palmitate

Content Ascorbyl Palmitate should contain not less than 95.0% of L-ascorbyl palmitate ($C_{22}H_{38}O_7$)

Description Ascorbyl Palmitate is white~pale yellow powder.

Identification Solution of Ascorbyl Palmitate in ethyl alcohol (1→10) decolorizes sodium 2,6-dichlorophenolindophenol solution (1→1,000).

- Purity**
- (1) Melting Point : Melting point of Ascorbyl Palmitate should be within a range of 107~117°C
 - (2) Specific Rotation : 1 g of Ascorbyl Palmitate is accurately weighed and dissolved in methyl alcohol to make 10 mL. Optical rotation of the solution is measured. When it is translated to dried material, it should be $[\alpha]_D^{20} = +21 \sim +24^\circ$.
 - (3) Arsenic : It should be no more than 4.0 ppm tested by Arsenic Limit Test.
 - (4) Lead : When 5.0 g of Ascorbyl Palmitate is tested by Atomic Absorption Spectrophotometry or Inductively Coupled Plasma Emission Spectroscopy, its content should not be more than 2.0 ppm.
 - (5) Mercury : When Ascorbyl Palmitate is tested by Mercury Limit Test, its content should not be more than 1.0 ppm.

Loss on Drying When Ascorbyl Palmitate is dried for 1 hours at 50~60°C in a vacuum desiccator, the weight loss should not be more than 2%.

Residues on Ignition When thermogravimetric analysis is done with approximately 2 g of Ascorbyl Palmitate, the amount of residues should not be more than 0.1%.

Assay Approximately 0.3 g of Ascorbyl Palmitate is accurately weighed and dissolved in 50 mL of ethyl alcohol in an 250 mL Erlenmeyer flask, add 30 mL of water. It is then titrated with 0.1 N iodine solution until the solution becomes yellow.

1 mL of 0.1 N sodium thiosulfate = 20.73 mg of $C_{22}H_{38}O_7$

Storage Standards of L-Ascorbyl Palmitate

Ascorbyl Palmitate should be stored in a light shielded hermetic container in a cold place.

L-Ascorbyl Stearate



Chemical Formula: $C_{24}H_{42}O_7$

Molecular Weight: 442.59

Synonyms: Ascorbyl stearate; Vitamin C stearate

INS No.: 305

CAS No.: 25395-66-8

Compositional Specifications of L-Ascorbyl Stearate

Content L-Ascorbyl Stearate should contain not less than 95.0% of L-ascorbyl stearate ($C_{24}H_{42}O_7$).

Description L-Ascorbyl Stearate occurs as a white to yellowish white powder.

Identification (1) To 0.1 g of L-Ascorbyl Stearate, add 100 mL of sodium lauryl sulfate-propylene glycol solution, and dissolve by warming. Cool, and add drop wise iodine solution to 5 mL of this solution until a slightly yellow color develops. Add each 1 drop of cupric sulfate solution (1→1,000) and pyrrole, and warm at 50 ~ 60°C for 5 minutes. A blue to blue-green color develops.

• Sodium lauryl sulfate-propylene glycol solution : 1 g of sodium lauryl sulfate is dissolved in 80 mL of water and propylene glycol is added. And then mix.

(2) To 10 mL of a solution of L-Ascorbyl Stearate in ethanol (1→100), add 1 or 2 drops of sodium 2, 6-dichlorophenolindophenol solution. The color of the solution becomes to blue and disappears immediately.

Purity (1) Melting Point : Melting point of L-Ascorbyl Stearate should be within a range of 114 ~ 119°C.

(2) Arsenic : It should be no more than 4.0 ppm tested by Arsenic Limit Test.

(3) Lead : When 5.0 g of L-Ascorbyl Stearate is tested by Atomic Absorption Spectrophotometry or Inductively Coupled Plasma Emission Spectroscopy, its content should not be more than 2.0 ppm.

(4) Mercury : When L-Ascorbyl Stearate is tested by Mercury Limit Test, its content should not be more than 1.0 ppm.

Loss on Drying When L-Ascorbyl Stearate is dried in a vacuum drying for 1 hour at 56 ~ 60°C, the weight loss should not be more than 2.0%.

Residue on Ignition When thermogravimetric analysis is done with 2 g of L-Ascorbyl Stearate, the residue should not be more than 0.1%.

Assay Accurately weigh about 0.2 g of L-Ascorbyl Stearate. add 30 mL of ethanol, and dissolve by warming if necessary. Add 15 mL of metaphosphoric acid solution (1→5) and 10 mL of sulfuric acid (1→2). Add 10 mL of potassium iodate solution, exactly measured, shake well, and allow to stand for 10 minutes in a dark place. Add 10 mL of potassium iodide solution and 100 mL of water, and allow to stand for 5 minutes in a dark place. Titrate the liberated iodine with 0.1 N sodium thiosulfate (indicator : 10 mL of starch solution). Perform a blank test in the same manner.

1 mL of 0.1 N sodium thiosulfate = 22.130 mg of $C_{24}H_{42}O_7$

Asparaginase

Definition Asparaginase is an enzyme obtained from a culture of *Aspergillus oryzae* and *Aspergillus niger*. Dilutant or stabilizer can be added for the purpose of activity adjustment and quality preservation.

Compositional Specifications of Asparaginase

Description Asparaginase is white~dark brown powder, granular, paste or colorless~dark brown liquid.

Identification When Asparaginase is proceeded as directed under Activity Test, it should have the activity as Asparaginase.

Purity (1) Arsenic : It should be no more than 4.0 ppm tested by Arsenic Limit Test.

(2) Lead : When 5.0 g of Asparaginase is tested by Atomic Absorption Spectrophotometry or Inductively Coupled Plasma Emission Spectroscopy, its content should not be more than 5.0 ppm.

(3) Coliform Group : When Asparaginase proceed as directed under Microbiological Methods for Coliform Group in General Testing Methods in 「Standards and Specifications for Foods」, it should not contain more than 30 per 1 g .

(4) Salmonella : When Asparaginase proceed as directed under Microbiological Methods for Salmonella in General Testing Methods in 「Standards and Specifications for Foods」, it should be negative (-).

(5) E. coli : When 25 g of Asparaginase is tested by Microbiological Methods for E. coli in General Test Method 「Standards and Specifications for Foods」, it should be negative (-).

Activity Test (activity)

If Asperginase is obtained from a culture of *Aspergillus oryzae*, use "Method 1" for activity test. If Asperginase is obtained from a culture of *Aspergillus niger*, use "Method 2" for activity test.

Method 1

Principle : The method 1 is to measure ammonia which is generated from the hydrolysis of L-asparagine at 37°C(pH 7.0). Ammonia is subsequently combined with α -ketoglutarate to form L-glutamic acid, and it is measured by the consumed amount of NADH(Nicotineamide adenine dinucleotide, reduced).

Preparation of test solution : A certain amount of sample is taken and diluted with MOPS buffer solution so that 1 mL of the final diluted solution contains 0.4 ~ 1.0 ASNU. This solution is used as test solution. (Adjust absorption to be in the range of about 0.10 ~ 0.25).

Procedure : Equilibrate 2.4 mL of substrate solution in the 37±0.1°C water bath for 10 minutes. Add 0.1 mL of test or control solution, immediately shaken, mixed and 1 mL of the solution transfer 1cm quartz cuvette. 0.1M MOPS buffer solution (pH 7.0) which contains Triton X-100, previously isothermalized, is used for blank test, and absorbance is rapidly measured at a 340 nm. Read the absorbance every 10 sec between 3 and 5 min from the start of the reaction for 2 min. (The absorbance at the reaction starting point should be 2.3 ~ 2.8. If the absorbance is below 2.3, prepare a new substrate solution). Carry out the test procedure in the same manner as above, at least twice for each test or control sample solution,

and measure slope of absorbance curve per minute ($\Delta A/\text{minute}$). This slope should agree within 15 %.

Calculate the activity(ASNU/g) of test or control sample as follows :

$$\text{ASNU/g} = \frac{\Delta A/\text{minute} \times 2.5 \times D}{0.1 \times 6.3 \times 1 \times W}$$

$\Delta A/\text{minute}$: The absolute value of the decrease of absorbance per min for the test or control sample solution

2.5 : Volume of the final reaction solution (mL)

D : Dilution factor

0.1 : Volume of test solution used(mL)

6.3 : Extinction coefficient of NADH ($\text{mL} \cdot \mu\text{mol}^{-1} \cdot \text{cm}^{-1}$)

1.0 : Length of extinction cell (cm)

W : Weight of sample (g)

Definition of Activity :

One asparaginase unit(ANSU) is the amount of enzyme that produces $1 \mu\text{mol}$ ammonia per minute under the above test operation condition.

Solutions

4M Sodium Hydroxide solution : Weigh 16 g of sodium hydroxide. Dissolve in water in a 100-mL volumetric flask. Add water to volume and mix until fully dissolved.

0.1M MOPS buffer solution (pH 7.0) : 20.9g of MOPS(Sigma M1254 or equivalent) dissolve in approximately 950mL of water in a 100 mL volumetric flask. pH is adjusted to 7.0 with 4M sodium hydroxide solution, 1mL of Triton X-100 (Sigma T9284 or equivalent) is added, and water is added to volume and mix. The solution must be used on the day of preparation.

Substrate solution : 0.25g of L-asparagine (Sigma A7094 or equivalent) is weighted into a 25-mL volumetric flask, 20 mL of MOPS buffer solution (pH 7.0) is added, completely dissolved, and 0.011g of NADH(Roche 107735 or equivalent) is added. Again, to this, 0.063g of α -ketoglutarate(Sigma K3752 or equivalent) and at least 2,000 units of glutamate dehydrogenase (Fluka 49392 or equivalent) are added, and MOPS buffer solution (pH 7.0) is added to make 25 mL. The composition of the solution : 10mg/mL L-asparagine, 2.5mg/mL α -ketoglutarate, 0.44mg/mL NADH, Glutamate dehydrogenase, >80 Unit/mL. This solution is stable for about 2 hours at room temperature.

Method 2

Principle : The method 2 is to measure ammonia which is generated from the hydrolysis of L-asparagine.

React ammonia with phenol nitroprusside and alkaline hypochlorite. Activity test is based on measuring blue color absorbance of it at 600nm.

Preparation of Test Solution : A certain amount of sample is taken and diluted with 0.1M Citric acid buffer solution(pH 5.0) so that 1mL of the final diluted solution contains 6 ASNU. This solution is used as test solution.

Preparation of standard curve : Weight accurately 3.0g of ammonium sulfate and dissolve in 40mL of 0.1M Citric acid buffer solution(pH 5.0) stirring to make 50mL. Measure 2mL, 5mL, 10mL and 15mL portion of this solution and to each, add 0.1M Citric acid buffer solution(pH 5.0) to make 50mL. 1mL of each solution contain 1.2, 2,4, 6, 12 and 18mg/mL of ammonium sulfate. Add 2mL of substrate solution in five test tube, warm it in the $37\pm 0.1^{\circ}\text{C}$ water bath for 10 minutes beforehand. Then, take 0.1mL of each standard solution and put in test tube. Shake immediately to mix and place in the $37\pm 0.1^{\circ}\text{C}$ water bath for exactly 30 minutes. Add 0.4mL of trichloroacetic acid solution, stir to mix and add 2.5mL of water(reaction solution). Put 0.8mL of water in separate tube, add 20 μL of reaction solution and mix it. Add 170 μL of phenol nitroprusside solution and mix. Add 170 μL of 0.2 % alkaline hypochlorite solution and mix. Place each solution in the $37\pm 0.1^{\circ}\text{C}$ water bath for 10 minutes. Measure the absorbance at 600nm and prepare the standard curve for concentrate(mg/mL) of standard solution.

Procedure : Take 2mL of substrate solution and put in test tube. Warm up in the $37\pm 0.1^{\circ}\text{C}$ water bath for 10 minutes beforehand. Add 0.1mL of test solution, shake immediately to mix and add 2.5mL of water(reaction solution). Put 0.8mL of water in separate tube, add 20 μL of reaction solution and mix it. Add 170 μL of phenol nitroprusside solution and mix. Add 170 μL of 0.2 % alkaline hypochlorite solution and mix. Place the solution in the $37\pm 0.1^{\circ}\text{C}$ water bath for 10 minutes. Measure the absorbance(A_T) of enzyme reaction solution at 600nm. Saperately, add 2mL of substrate solution and 0.4mL of trichloroacetic acid solution and mix. Add 0.1mL of test solution and place the solution in the $37\pm 0.1^{\circ}\text{C}$ water bath for 30 minutes and then add 0.8 mL of water. Put 0.8mL of water in separate tube, add 20 μL of reaction solution and mix it. Add 170 μL of phenol nitroprusside solution and mix. Add 170 μL of 0.2 % alkaline hypochlorite solution and mix. Place the solution in the $37\pm 0.1^{\circ}\text{C}$ water bath for 10 minutes. Measure the absorbance(A_B) of enzyme blank test solution at 600nm.

Calculate the activity(ASNU/g) by the formula below:

$$\text{ASNU/g} = \frac{(A_T - A_B) \times V \times D \times 2 \times 10^6}{a \times 132.14 \times W \times 30 \times 10^3}$$

A_T : Absorbance of enzyme reaction solution

A_B : Absorbance of enzyme blank test solution

V : Initial volume of test solution (mL)

D : Dilution factor of the sample

a : Slope of the standard curve (mL/mg)

W : Weight of the sample (g)

30 : Reaction time (min)

Definition of Activity :

One asparaginase unit(ANSU) is the amount of enzyme that produces 1 μ mol ammonia per minute under the above test operation condition.

Solutions

Substrate solution : Dissolve L-Asparagine(monohydrate) in 80mL of 0.1M citric acid buffer solution(pH 5.0) to make 100mL. This solution prepare immediately when used.

4M Sodium hydroxide solution : Dissolve 160g of Sodium hydroxide in 800mL of water to make 1000mL.

0.1M Citric acid buffer solution : Dissolve 21.01g of Citric acid(monohydrate) in 900mL of water. pH is adjusted to 5.0 with 4M sodium hydroxide solution and add water to make 1000mL.

Trichloroacetic acid solution : Mix 25g of trichloroacetic acid and water to make 100mL.

Storage Standards of Asparaginase

Asparaginase should be stored in a hermetic container in a cold dark place.

L-Asparagine

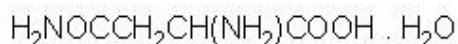

Chemical Formula: $\text{C}_4\text{H}_8\text{N}_2\text{O}_3 \cdot \text{H}_2\text{O}$

Molecular Weight: 150.13

Synonyms: L- α -Aminosuccinamic Acid

CAS No.: 70-47-3

Compositional Specifications of L-Asparagine

Content If L-Asparagine is converted to a dried form, it should contain 98.0~102.0% L-asparagine ($\text{C}_4\text{H}_8\text{N}_2\text{O}_3$).

Description L-Asparagine is scentless white crystal or crystalline powder with slightly sweet taste.

Identification (1) 1 mL of ninhydrine solution (1→50) is added to 5 mL aqueous solution of L-Asparagine (1→1,000). Upon heating for 3 minutes in a water bath, this solution turns violet.

(2) 5 mL of sodium hydroxide solution (1→10) is added to 0.1 g of L-Asparagine, which is then heated in a water bath. The resulting gas (NH_3) turns water-wet litmus paper blue.

Purity (1) Clarity and Color of Solution : When dissolve 1 g of L-Asparagine in 50 mL water, it should be clear.

(2) pH : When dissolve 1 g of L-Asparagine in 100 mL water, it should have a pH range of 3.5~5.5.

(3) Specific Rotation : 10 g of L-Asparagine is accurately weighed, which is dissolved in 6 N hydrochloric acid so that the total volume becomes 100 mL. Optical rotation of the solution is measured. When it is translated to dried material, $[\alpha]_D^{20} = +33.0 \sim +36.5^\circ$

(4) Chlorides : When 0.07 g of L-Asparagine is tested by Chloride Limit Test, the content should not be more than the amount that corresponds to 0.2 mL of 0.01 N hydrochloric acid.

(5) Arsenic : It should be no more than 4.0 ppm tested by Arsenic Limit Test.

(6) Lead : When 5.0 g of L-Asparagine is tested by Atomic Absorption Spectrophotometry or Inductively Coupled Plasma Emission Spectroscopy, its content should not be more than 5.0 ppm.

Loss on Drying When L-Asparagine is dried for 3 hours at 130°C, the weight loss should not be more than 12.5%.

Residue on Ignition Residue after ignition should not be more than 0.1%.

Assay Approximately 0.3 g is accurately weighed and dissolved in 3 mL of formic acid, where glacial acetic acid (for non-aqueous titration) is added to bring the total volume to 50 mL. This solution is titrated with 0.1 N perchloric acid solution (indicator : 1 mL of crystal violet buffered in glacial acetic acid). At the end point, the solution turns from pale violet to blue, then to green. Separately, a blank test is done following the same procedure.

0.1 N perchloric acid solution 1 mL = 13.212 mg $C_4H_8N_2O_3$

Aspartame



Chemical Formula: $C_{14}H_{18}N_2O_5$

Molecular Weight: 294.31

INS No.: 951

Synonyms: Aspartyl phenylalanine methyl ester

CAS No.: 22839-47-0

Compositional Specifications of Aspartame

Content Aspartame, when calculated on the dried basis, should contain within a range of 98.0~102.0% of aspartame ($C_{14}H_{18}N_2O_5$).

Description Aspartame occurs as a white crystalline powder or granules. It is odorless and has a strong sweet taste.

Identification (1) To 10 mg of Aspartame, add 3 mL of water and 2 mL of ninhydrin-hydrindantin solution (2 g of ninhydrin is dissolved in 75 mL of dimethylsulfoxide, where 62 mg of hydrindantin and 4 M acetate lithium buffer solution, pH 9.0 are added to make 100 mL of solution), and heat. A black-purple color develops.

(2) Dissolve 20 mg of Aspartame in 1 mL of methanol, add 0.5 mL of methanol saturated with hydroxylamine hydrochloride, mix, then add 0.3 mL of methanolic 35% potassium hydroxide solution, and boil in a water bath. Cool, adjust the pH to 1.0~1.5 with 0.1 N hydrochloric acid, and add 0.1 mL of ferric chloride solution (1→100). A deep red-purple color develops.

Purity (1) Clarity and Color of Solution : When 1 g of Aspartame is dissolved in 0.2 N hydrochloric acid to make 100 mL solution, it should be colorless and clear.

(2) pH : Weigh 0.8 g of Aspartame, and dissolve it in water to make 100 mL. pH of this solution should be within a range of 4.5 ~ 6.0.

(3) Specific Rotation : Approximately 2 g of Aspartame is accurately weighed, which is dissolved in 15 N folic acid within 30 minutes so that the total volume becomes 50 mL. Optical rotation of the solution is measured. When it is translated to dried material, it should be $[\alpha]_D^{20} = +12.5 \sim +17.5^\circ$.

(4) Arsenic : It should be no more than 4.0 ppm tested by Arsenic Limit Test.

(5) Lead : When 5.0 g of Aspartame is tested by Atomic Absorption Spectrophotometry or Inductively Coupled Plasma Emission Spectroscopy, its content should not be more than 1.0 ppm.

(6) 5-Benzyl-3,6-Dioxo-2-Piperazine Acetic Acid : Weigh 10 mg of Aspartame, place into a test tube 3 mL with a stopper, add 1.0 mL of silylation solution and shake. Heat at 80°C for 30 minutes, shake for 15 seconds, allow to cool, and use as the test solution. Measure separately 3 mL of a standard solution,

place into a test tube with a stopper, evaporate to dryness on a water bath, add 1 mL of silylation solution to the residue, and proceed as in the case of the sample. Perform Gas Chromatography under the operation conditions given below. The content should not be more than 1.5%.

$$\text{5-benzyl-3,6-dioxo-2-piperazine acetate content(\%)} = \text{St(mg)} \times \frac{\text{Peak height of Sa}}{\text{Peak height of St}} \times \frac{1}{\text{Sa(mg)}} \times \frac{100}{167}$$

Operation Conditions

- Injector : Microtech 220 or its equivalent.
- Column : inner diameter 3~4 mm, length 2 m glass tube
- Column filler : 80~100 Mesh Schupelcoport or its equivalent, approximately 3% of porous support for gas chromatography
- Detector : hydrogen flame ionization detector (FID)
- Temperature at injection port : 200°C
- Column temperature : 200°C
- Detector temperature : 275°C
- Carrier gas and flow rate : nitrogen, flow rate is adjusted so that 5-benzyl-3,6-dioxo-2-piperazineacetic acid is detected after about 7 ~ 9 minutes

Solutions

- Silylation Solution : N,O-bis(trimethylsilyl)acetamide and dimethylformamide is mixed at a ratio of 3 : 2 . Prepared it before using.
 - Standard Solution : 25 mg of 5-benzyl-3,6-dioxo-2-piperazine acetate standard is accurately weighed into a 50 mL flask and dissolved in methyl alcohol to make 50 mL solution. 10 mL of this solution is diluted to 100 mL with methyl alcohol.
- (7) Transmittance : 1% of Aspartame in 2 N hydrochloric acid should have the absorbance of 0.022 at 430 nm (spectrophotometer, 1cm path length, reference solution : 2 N hydrochloric acid)

Loss on Drying When Aspartame is dried for 4 hours at 105°C, the weight loss should not be more than 4.5%.

Residue on Ignition Residue after ignition should not be more than 0.2%.

Assay Approximately 0.3 g of Aspartame is accurately weighed and dissolved in 3 mL of formic acid. After adding 50 mL of glacial acetic acid to this solution, it is titrated with 0.1 N perchloric acid (indicator : 0.5 mL of α -naphthol benzene). The end point is where the solution changes its color from brown to green. Separately, a blank test is carried out for the correction by the same method and it is converted into a dried form.

$$1 \text{ mL of } 0.1 \text{ N perchloric acid} = 29.431 \text{ mg } \text{C}_{14}\text{H}_{18}\text{N}_2\text{O}_5$$

L-Aspartic Acid

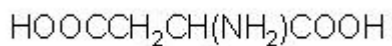

Chemical Formula: $\text{C}_4\text{H}_7\text{NO}_4$

Molecular Weight: 133.10

Synonyms: L-Asparaginic acid; L-aminosuccinic acid

CAS No.: 56-84-8

Compositional Specifications of L-Aspartic Acid

Content If L-Aspartic Acid is converted to a dried form, it should contain 98.0~102.0% L-Aspartic acid ($\text{C}_4\text{H}_7\text{NO}_4$).

Description L-Aspartic Acid is a scentless white crystal or crystalline powder with slightly sour taste.

Identification (1) 1 mL of ninhydrine solution (1→50) is added to 5 mL aqueous solution of L-Aspartic Acid (1→1,000). Upon heating for 3 minutes in a water bath, this solution turns blue-purple color.

(2) L-Aspartic Acid is dissolved in 1 N hydrochloric acid (1→25). Upon adding 1 mL of sodium nitrite standard solution to 5 mL of this solution, colorless gas evolves with bubbles.

Purity (1) Clarity and Color of Solution : A solution of 1 g of L-Aspartic Acid in 20 mL of 1 N hydrochloric acid should be colorless and clear.

(2) pH : Saturated aqueous solution of L-Aspartic Acid should have pH of 2.5~3.5.

(3) Specific Rotation : 8 g of L-Aspartic Acid is accurately weighed, which is dissolved in 6 N hydrochloric acid so that the total volume becomes 100 mL. Optical rotation of the solution is measured. When it is translated to dried material, it should be $[\alpha]_D^{20} = +24.0 \sim +26.0^\circ$.

(4) Chlorides : When 0.07 g of L-Aspartic Acid is tested by Chloride Limit Test, the content should not be more than the amount that corresponds to 0.2 mL of 0.01 N hydrochloric acid.

(5) Arsenic : It should be no more than 4.0 ppm tested by Arsenic Limit Test.

(6) Lead : When 5.0 g of L-Aspartic Acid is tested by Atomic Absorption Spectrophotometry or Inductively Coupled Plasma Emission Spectroscopy, its content should not be more than 5.0 ppm.

Loss on Drying When L-Aspartic Acid is dried for 3 hours at 105°C, the weight loss should not be more than 0.3%.

Residue on Ignition Residue after ignition should not be more than 0.1%.

Assay Approximately 0.3 g is accurately weighed and dissolved in 6 mL of formic acid, where glacial acetic acid (for non-aqueous titration) is added to bring the total volume to 50 mL. This solution is titrated with 0.1 N perchloric acid solution (indicator : 1 mL of crystal violet buffered in glacial acetic acid). At the end point, the solution turns from pale violet to blue, then to green. Separately, a blank

test is done following the same procedure.

0.1 N perchloric acid solution 1 mL = 13.310 mg $C_4H_7NO_4$

Azodicarbonamide

Chemical Formula: $C_2H_4N_4O_2$

Molecular Weight: 116.08

INS No.: 927a

Synonyms: Azobisformamide

CAS No.: 123-77-3

Compositional Specifications of Azodicarbonamide

Content Azodicarbonamide, when calculated on the dried basis, should contain not less than 98.6% of azodicarbonamide ($C_2H_4N_4O_2$).

Description Azodicarbonamide is yellow ~ orange red scentless crystalline powder.

Identification (1) A solution of 35 mg of Azodicarbonamide in 1000 mL of water exhibits an ultraviolet absorption maximum at a wavelength of 245 nm.

(2) Transfer 10 mg of Azodicarbonamide into a crucible, heat, and add a few drops of barium hydroxide standard solution. The liquid turns turbid.

Purity (1) pH : To 2 g of Azodicarbonamide, add 100 mL of water and suspend for 5 minutes. pH of this suspension should not less than 5.0.

(2) Arsenic : It should be no more than 4.0 ppm tested by Arsenic Limit Test.

(3) Lead : When 5.0 g of Azodicarbonamide is tested by Atomic Absorption Spectrophotometry or Inductively Coupled Plasma Emission Spectroscopy, its content should not be more than 2.0 ppm.

(4) Nitrogen : 50 mg of Azodicarbonamide is transferred into a 100 mL flask for decomposition. To decompose Azodicarbonamide, 3 mL of freshly prepared 57% hydroiodic acid solution is added and then heated for 1 hour and 30 minutes. Sufficient amount of water is added to maintain the initial volume of the liquid. After decomposition is complete, the flask is heated at a higher temperature so that the volume is reduced to 1/2. After cooling, the liquid is continuously decomposed and tested by Kjeldahl Nitrogen Test (nitrogen determination method) and the amount should be within a range of 47.2 ~ 48.7%.

Loss on Drying When Azodicarbonamide is dried for 2 hours at 50°C under a reduced pressure, the weight loss should not be more than 0.5%.

Residue on Ignition Residue on ignition of Azodicarbonamide should not be more than 0.15%.

Assay Accurately weigh 225 mg of dried material, transfer into a 250 mL iodine flask with a glass stop cock, and dissolve it in 25 mL dimethylsulfoxide (DMSO). After adding 5 g of potassium iodide, 15 mL of water, and 10 mL of hydrochloric acid, the stop cock is quickly placed on the flask, which is then kept in a dark place for 20 ~ 25 minutes (it needs to be shaken until potassium iodide is dissolved). Free iodine is titrated with 0.1N sodium thiosulfate (indicator : starch standard solution). Separately, a blank test is done following the same procedure.

1 mL of 0.1 N sodium thiosulfate solution = 5.804 mg $C_2H_4N_4O_2$

Beeswax

INS No.: 901

CAS No.: 8012-89-3

Definition There are two grades, beeswax (white) and beeswax (yellow). Honey comb of honey bee (*Apis mellifera* L., *Apis indica* Radoszkowski) is heated, pressure-filtered, and purified to obtain beeswax (yellow), which is then bleached to obtain beeswax (white).

Compositional Specifications of Beeswax

Description Beeswax (white) is white~yellowish white solid having a faint and characteristic odor. Beeswax (yellow) is yellow ~ grayish brown solid with honey like odor.

Purity (1) Arsenic : It should be no more than 4.0 ppm tested by Arsenic Limit Test.

(2) Lead : When 5.0 g of Beeswax is tested by Atomic Absorption Spectrophotometry or Inductively Coupled Plasma Emission Spectroscopy, its content should not be more than 2.0 ppm.

(3) Mercury : When Beeswax is tested by Mercury Test Method, its content should not be more than 1.0 ppm.

(4) Melting Point : Melting point of Beeswax should be in a temperature range of 62~65°C.

(5) Acid value : 3 g of Beeswax is accurately weighed and transferred into a 200 mL Erlenmeyer flask with 25 mL of anhydrous alcohol, previously neutralized to phenolphthalein with potassium hydroxide, until the sample is melted, Test Solution. When is tested by Mercury Test in Oil and Fats Method, acid value should be 17 ~ 24 for beeswax (white) and 18 ~ 24 for beeswax (yellow).

(6) Ester Value : 25 mL of 0.5 N alcoholic potassium hydroxide and 50 mL of alcohol are added to the Test Solution for acid value. A reflux condenser is attached and the solution is heated for 4 hours in a water bath. Excess alkali is titrated with 0.5 N hydrochloric acid and ester value is calculated by the following equation. Ester value should be 72 ~ 79 for beeswax (white) and 72 ~ 77 for beeswax (yellow). Separately, a blank test is carried out.

$$\text{Ester Value} = \frac{(a-b) \times 28.05}{\text{weight of the sample(g)}}$$

a : Consumed amount of 0.5 N hydrochloric acid for blank test (mL)

b : Consumed amount of 0.5 N hydrochloric acid for Test Solution (mL)

- (7) Carnauba Wax : 100 mg of the sample is weighed and transferred into a test tube, where 20 mL of n-butyl alcohol is added. The test tube is heated in a boiling water bath and shaken until it becomes transparent. The test tube is placed in a beaker with 60°C water, which is then allow it to cool to room temperature. Loose, fine, needlelike crystals are separated from the solution and observed under a microscope. Crystals appear as loose needle or stellate clusters, no amorphous masses are observed.
- (8) Fat, Japan Wax, Rosin, and Soap : 35 mL of sodium hydroxide solution (1→7) is added to 1 g of Beeswax, which is boiled for 30 minutes while occasionally adding water to supplement loss. After cooling, wax is separated so that the liquid remain clear. This liquid is then filtered. When the filtrate is acidified with hydrochloric acid, precipitates should not form.
- (9) Saponification Cloud Test : 3 g of Beeswax is weighed and transferred into a 100 mL round bottom flask, where 30 mL of potassium hydroxide solution (saponifying solution) in aldehyde free alcohol (40→1,000) is added. After attaching a reflux condenser to the flask, gently heated for 2 hours in a water bath. The condenser is removed, and inserted a thermometer, and the flask is placed in a 80°C water bath. It is then cooled to 65°C by shaking. The solution shows no cloudiness or globule formation before the solution reaches 65°C.
- (10) Saponification Value : 5 g of Beeswax is accurately weighed and transferred into a flask, where 50 mL of 0.5 N alcoholic solution of potassium hydroxide is added. After attaching a reflux condenser, the solution is gently saponified for 30 minutes to 1 hour. The saponified solution is used as Test Solution. The test solution is proceeded as directed under saponification value in Oils and Fats Test. The saponification value of the solution should be 87 ~ 104.
- (11) Peroxides value : 5 g of Beeswax is accurately weighed into a 250 mL round bottom erlenmeyer flask, 35 mL of Acetic acid.Chloroform mixture (3:2) is added, and gently shaken to be dissolved transparently. Clean nitrogen is passed through this to substitute the air in the container. When nitrogen is passed, 1 mL of potassium iodide TS is accurately weighed into the container. Stop the nitrogen, a stopper is immediately placed, mixed for 1 minutes, and allow to stand for 5 minutes in a dark place. 75 mL of water is added, and vigorously shaken and it is titrated with 0.01N sodium thiosulfate (indicator : starch standard TS). When Peroxides value is obtained with following equation, the value sholud not be more than 5. Separately, a blank test is done to correct.

$$\text{Peroxides value} = \frac{\text{consumed amount of 0.01N sodium thiosulfate (mL)}}{\text{Weight of sample(g)}} \times 10$$

- (12) Ceresin , paraffin and other wax : 3g of Beeswax is accurately weighed and transferred into a 100 mL round-bottomed flask, where 30 mL of 4% alcoholic solution of potassium hydroxide solution is added. A reflux condenser is attached to the flask. It is then heated for 2 hours in a water bath, condenser is removed and thermometer is equipped. The flask is continuously shaken and slowly

cooled in a beaker where 80°C water is, precipitates should not be formed before it reaches 65°C.

(13) Glycerol and other polyol : 0.2 g of Beeswax is accurately weighed and transferred into a round-bottomed flask, where 10 mL of 4% alcoholic solution of potassium hydroxide solution is added. A reflux condenser is attached to the flask. It is then heated in a water bath for 30 minutes, again 50 mL of 10% sulfuric acid is added, cooled, and filtered. The resultant solution diluted to 100 mL with 10% sulfuric acid, test solution. 1.0 mL of test solution is placed in test tube, 0.5 mL of 1.0% sodium periodate is added, mixed, and allow to stand for 5 minutes. 1.0 mL of fuchsin sulfurous acid TS is added and mixed. Test tube is placed 10~15 minutes in a beaker containing water at 40°C, the bluish-violet color in the solution is not more intense than a standard prepared at the same time in the same manner using 1.0 mL of a 0.001% solution of glycerol(dissolved in 10% sulfuric acid) (Not be more than 0.5 % as glycerol).

Beet Red

INS No.: 162

Synonyms: Beetroot red

CAS No.: 7659-95-2(Betanin)

Definition Beet Red is a pigment obtained from extracting roots of beet (*Beta vulgaris* Linné) of chenopodiaceae with water or ethyl alcohol. The major component is isobetanine and betanine. Dilutant, stabilizer, or solvent can be added for the purpose of color value adjustment and quality preservation.

Compositional Specifications of Beet Red

Content Color value ($E_{1cm}^{10\%}$) of Beet Red should not be less than the indicated value.

Description Beet Red is reddish violet ~ dark violet liquid, lump, powder, or paste with a slight characteristic odor.

Identification (1) Test Solution of Beet Red obtained in Color Value section shows reddish violet and a absorbance maximum at about 535 nm.

(2) When 1 mL of sodium hydroxide solution(1→10) is added to 5 mL of Test Solution in (1), the colour changes yellow.

Purity (1) Arsenic : It should be no more than 4.0 ppm tested by Arsenic Limit Test.

(2) Lead : When 5.0 g of Beet Red is tested by Atomic Absorption Spectrophotometry or Inductively Coupled Plasma Emission Spectroscopy, its content should not be more than 2.0 ppm.

(3) Cadmium : When 5.0 g of Beet Red is tested by Atomic Absorption Spectrophotometry or Inductively Coupled Plasma Emission Spectroscopy, its content should not be more than 1.0 ppm.

(4) Mercury : When 0.1 g of Beet Red is tested by Mercury Test Method, its content should not be more than 1.0ppm.

(5) Nitrate : 0.1 g of Beet Red is accurately weighed and transferred into water to make 100 mL, Test Solution. Separately, take 0.2 mL, 1 mL, 10 mL and 50 mL of Nitrate standard stock solution and add water to make to 100 mL, standard solution respectively. Measure the peak area of nitrate ion of standard solution and standard stock solution and plot the calibration curve. When measure the peak area of nitrate ion of test solution and plot the calibration curve, the calculated content of nitrate(NO_3) should not be more than 0.27%(based on the product whose color value is 15).

Operation condition

Detector: Conductivity detector

Filler: Porous anion exchnager

Column: Inner diameter 4.6~6.0 mm length 5~10 cm Stainless steel tube

Temperature of column: 40 °C

Eluent: Aqueous solution(pH 4.0) contains phthalic acid(2.5 mmol/L) and tris(hydroxymethyl)aminomethane(2.4 mmol/L)

Rate of discharge: 1.5mL/min

Solution

Standard nitrate stock solution : 1.631 g of potassium nitrate is accurately weighed and water is added to make 1,000 mL. 10mL of this solution is taken into water to make accurately 100mL(1 mL of this solution contains 0.1mg of nitrate(NO_3))

Assay(color value) Appropriate amount of Beet Red is accurately weighed so that the absorption is within the range of 0.3 to 0.7 and dissolved in acetic acid.sodium acetate buffer solution with pH 5.4 to make 100 mL. 1 mL of this solution is diluted to 100 mL with acetic acid-sodium acetate buffer solution with pH 5.4, Test Solution. If necessary, the solution is centrifuged and the supernatant is used. Using acetic acid-sodium acetate buffer solution with pH 5.4 as a blank, absorbance A is measured at the maximum absorption at about 535 nm with 1 cm path length. Color value is obtained using the following equation.

$$\text{Color Value} \left(\frac{E_{1\text{cm}}^{1\%}}{1\text{cm}} \right) = \frac{A \times 1,000}{\text{weight of the sample(g)}}$$

• Acetic acid · sodium acetate buffer solution (pH 5.4)

Solution 1 : 1,000 mL of solution containing 13.6 g of sodium acetate.

Solution 2 : 1,000 mL of solution containing 6 mL of glacial acetic.

Solution 1 and Solution 2 are mixed well (8:2) and its pH is adjusted to 5.4.

Bentonite

INS No.: 558

CAS No.: 1302-78-9

Definition Bentonite is naturally occurring colloidal hydrated aluminum silicate.

Compositional Specifications of Bentonite

Description Bentonite is odorless white ~ pale yellowish brown powder or granule with a slight taste similar to soil or clay when it is wetted with water.

Identification (1) 0.2 g of Bentonite is mixed with 1.5 g of 50 : 50 mixture of anhydrous sodium carbonate and anhydrous potassium carbonate. It is then heated until it melts completely in a platinum or nickel crucible. After cooling, 5 mL of water is added and allow to stand for 3 minutes. The bottom of the crucible is gently heated and then the solidified matter is transferred into a beaker along with water. Hydrochloric acid is slowly added until foaming stops. After adding 10 mL more of hydrochloric acid, it is evaporated to dryness. 200 mL of water is added to the residue, which is boiled and filtered. Gel phase residue is transferred into a platinum crucible. When 5 mL of hydrofluoric acid is added, and dissolved. Upon heating, it volatilized almost.

(2) The filtrate in (1) shows the reaction of aluminum salt in Identification.

(3) When Bentonite is immersed in water, the volume swells up to 5 times.

Purity (1) Foreign Substances : 2 g of Bentonite is weighed and transferred into a mortar, where 20 mL of water is added and let it swells. It is evenly dispersed using a glass rod and water is added to bring the total volume to 100 mL. The dispersion is passed through a No.7 mesh screen using water. When the mesh screen is rubbed with finger tips, there should not be any sand.

(2) Arsenic : It should be no more than 4.0 ppm tested by Arsenic Limit Test.

(3) Lead : 5.0 g of dried sample is weighed and transferred into a 250 mL beaker containing 100 mL of diluted hydrochloric acid (1→25). It is then stirred, covered with a watch glass, and boiled for 15 minutes. After cooling to room temperature, the beaker is allowed insoluble matter to settle. The supernatant is filtered through a filter paper. The filter paper is washed with four 25 mL portions of hot water, collecting the filtrate in the beaker. The combined filtrate is concentrated by gentle boiling to approximately 20 mL. If a precipitate are formed, 2 ~ 3 drops of nitric acid are added and boiled again. After cooling to room temperature, the concentrated extracts is filtered through a rapid-flow filter paper. The beaker and the filter paper are washed with water and the washing water is added to the filtrate. The total volume is brought up to 50 mL with water, Test Solution. When this test solution is tested by Atomic Absorption Spectrophotometry or Inductively Coupled Plasma Emission Spectroscopy, its content should not be more than 20.0 ppm.

(4) Total Viable Aerobic Count : When Bentonite is tested by Microbe Test Methods for Total Viable Aerobic Count (Number of General Germs) in General Test Method in 「Standards and Specifications for Foods」, it should not be more than 1,000 per 1 g.

(5) E. Coli : When Bentonite is tested by Microbe Test Methods for E. Coli in General Test Method 「Standards and Specifications for Foods」, it should be negative (-).

Loss on Drying When 2 g of Bentonite is dried at 110°C until the weight becomes constant, the weight loss should not be more than 5 ~ 10%.

Swelling Test 2 g of Bentonite is added ,in several divided portions, to a 100 mL graduated cylinder with a stopper containing water. After the previous portion added settles down, the next portion added. Leave undisturbed for 24 hours, the volume of the swollen lump on bottom should read 10 mL or higher.

Benzaldehyde



Chemical Formula: C₇H₆O

Molecular Weight: 106.12

Synonyms: Benzene methylal

CAS No.: 100-52-7

Compositional Specifications of Benzaldehyde

Content Benzaldehyde should contain not less than 98.0% of benzaldehyde (C₇H₆O).

Description Benzaldehyde is a colorless liquid having an almond-like odor.

Identification (1) To 1 mL of Benzaldehyde, add 3 mL of sodium hydrogen bisulfite solution, and shake.

The mixture evolves heat immediately and forms crystalline lumps. Add 5 mL of water to this mixture.

The crystalline lumps are dissolved.

(2) To 3 drops of Benzaldehyde, add 0.1 g of phenol and 2 mL of sulfuric acid, and shake. The color of this solution becomes dark-red, and the mixture partly forms resinous lumps. Take 2 drops of this solution, add 5 mL of water, and make alkaline with sodium hydroxide solution. The color becomes purple.

Purity (1) Specific Gravity : Specific gravity of Benzaldehyde should be within a range of 1.041~1.046

(2) Refractive Index : Refractive Index n_D^{20} of Benzaldehyde should be within a range of 1.544 ~ 1.547

(3) Chlorides : When Benzaldehyde is tested by Copper Mesh Test Method for Halogens in Test Methods for Flavorings, it should be appropriate.

Assay Accurately weigh about 0.8 g of Benzaldehyde, and proceed as directed under hydroxyl amine Method 2 in Aldehyde and Ketone Content in Flavoring Substances Tests. In the procedure, allow the mixture to stand for 10 minutes.

1 mL of 0.5 N hydrochloric acid = 53.06 mg of C₇H₆O

Benzoic Acid



Chemical Formula: $C_7H_6O_2$

Molecular Weight: 122.12

Synonyms: Benzenecarboxylic acid

INS No.: 210

CAS No.: 65-85-0

Compositional Specifications of Benzoic Acid

Content Benzoic Acid, when calculated on the dried basis, should contain not less than 99.5% of benzoic acid ($C_7H_6O_2$)

Description Benzoic Acid occurs as white laminar crystals or needles. It is odorless or has a slight odor of benzaldehyde.

Identification Dissolve Benzoic Acid in sodium hydroxide solution (1→20). The Solution responds to the test for Benzoate.

Purity (1) Melting Point : Melting point of Benzoic Acid should be within a range of 121 ~ 123°C

(2) Chlorides : Weigh 0.5 g of Benzoic Acid and 0.7 g of calcium carbonate, transfer into a porcelain crucible, add a small amount of water, mix, dry at 100°C, and heat at about 600°C for 10 minutes. After cooling, add 20 mL of diluted nitric acid to dissolve the residue, and filter. Wash the insoluble substances with about 15 mL of water, combine the washings and the filtrate, add water to make 50 mL. This solution is used as test solution. Weigh 0.7 g of calcium carbonate, dissolve it in 20 mL of diluted nitric acid, filter if necessary, add 0.2 mL of 0.01 N hydrochloric acid and water, shake well, and allow to stand for 5 minutes. This solution is used as the reference solution. The test solution is not more turbid than the reference solution.

(3) Phthalic acid : 0.1 g of Benzoic Acid is transferred into a test tube, where freshly sublimed 2 ~ 3 mg of resorcin and 1 mL of sulfuric acid are added and shaken. It is heated for 5 minutes at 125~130°C. After cooling, water is added to make 5 mL of solution. While cooling, it is alkalinized by adding sodium hydroxide solution (2→5) drop-wise. The resulting solution is diluted to 10 mL with water. It should not show green fluorescence under UV.

(4) Arsenic : It should be no more than 4.0 ppm tested by Arsenic Limit Test.

(5) Lead : When 5.0 g of Benzoic Acid is tested by Atomic Absorption Spectrophotometry or Inductively Coupled Plasma Emission Spectroscopy, its content should not be more than 2.0 ppm.

(6) Mercury : When Benzoic Acid is tested by Mercury Limit Test, its content should not be more than 1.0 ppm.

(7) Readily Carbonizable Substances : When 0.5 g of Benzoic Acid is tested for Readily Carbonizable Substances, its color should not be darker than the Color Standard Solution Q.

(8) Readily Oxidizable Substances : Add 1.5 mL of sulfuric acid to 100 mL of water, add drop wise 0.1 N potassium permanganate while boiling until the pink color persists for 30 seconds. Weigh 1 g of Benzoic Acid, and dissolve it in the solution. Titrate with 0.1 N potassium permanganate at about 70°C until the pink color persists for 15 seconds. The amount should not be more than 0.5 mL.

Loss on Drying When Benzoic Acid is dried for 3 hours in a vacuum desiccator (silica gel), the weight loss should not be more than 0.5%.

Residue on Ignition Residue after ignition should not be more than 0.05%.

Assay Accurately weigh about 0.25 g of Benzoic Acid, after dried, dissolve in 25 mL of 50% v/v ethanol neutralized with 0.1 N sodium hydroxide, and titrate with 0.1 N sodium hydroxide (indicator : 3 drops of phenol red solution).

1 mL of 0.1 N sodium hydroxide = 12.21 mg of $C_7H_6O_2$

Benzyl Acetate

Chemical Formula: $C_9H_{10}O_2$

Molecular Weight: 150.18

Synonyms: Benzyl ethanoate

CAS No.: 140-11-4

Compositional Specifications of Benzyl Acetate

Content Linalyl Acetate should contain not less than 98.0% of benzyl acetate ($C_9H_{10}O_2$).

Description Linalyl Acetate is a colorless, transparent liquid having a characteristic odor.

Identification To 1 mL of Benzyl Acetate, add 5 mL of 10% alcoholic solution of potassium hydroxide. Warm in hot water for 20 minutes. The characteristic odor disappears. Cool, and add 8 mL of water and 1 mL of diluted hydrochloric acid. The solution responds to the test for Acetate (C) in Identification.

- Purity**
- (1) Specific Gravity : Specific gravity of Benzyl Acetate should be within a range of 1.052 ~ 1.056
 - (2) Refractive Index : Refractive Index n_D^{20} of Benzyl Acetate should be within a range of 1.501 ~ 1.504
 - (3) Clarity and Color of Solution : When 1 mL of Linalyl Acetate is dissolved in 5 mL of 60% alcohol, the solution should be clear.
 - (4) Acid Value : Acid value of Linalyl Acetate is tested by Acid Value in Flavoring Substance Test. It should not be more than 1.
 - (5) Chloride : When Linalyl Acetate is tested by Copper Mesh Test Method in Halogenated Compounds for Flavoring, it should be appropriate.

Assay Accurately weigh about 0.8 g of Benzyl Acetate, and proceed as directed under Ester Value and Ester Content in Flavoring Substances Tests.

1 mL of 0.5 N alcoholic solution of potassium hydroxide = 75.09 mg of $C_9H_{10}O_2$

Benzyl Alcohol



Chemical Formula: C₇H₈O

Molecular Weight: 108.14

Synonyms: Benzene methanol

INS No.: 1519

CAS No.: 100-51-6

Compositional Specifications of Benzyl Alcohol

Content Benzyl Alcohol should contain not less than 98.0% of benzyl alcohol (C₇H₈O).

Description Benzyl Alcohol is a colorless, transparent liquid having a characteristic odor.

Identification Add 2 ~ 3 drops of Benzyl Alcohol to 5 mL of potassium permanganate solution (1→20), and acidify with diluted sulfuric acid. An odor of benzaldehyde is evolved.

- Purity**
- (1) Specific Gravity : Specific gravity of Benzyl Alcohol should be within a range of 1.042 ~ 1.047
 - (2) Refractive Index : Refractive Index n_D^{20} of Benzyl Alcohol should be within a range of 1.539 ~ 1.541
 - (3) Clarity and Color of Solution : When 1 mL of Benzyl Alcohol is dissolved in 50 mL of water, even though the solution is turbid, the oily layer should not be separated immediately.
 - (4) Chlorides : When Benzyl Alcohol is tested by Copper Mesh Test Method in Halogenated Compounds for Flavoring, it should be appropriate.
 - (5) Free Acid and Free Alkali : Dissolve 100 mL of Benzyl Alcohol in 10 mL of neutralized ethanol, and add 2 drops of phenolphthalein solution. No pink color develops. When add 0.2 mL of 0.1 N sodium hydroxide in this solution and shake, the color becomes pink.
 - (6) Aldehyde : Weigh exactly 5 g of Benzyl Alcohol, and proceed as directed under hydroxyl amine Method 2 in Aldehyde and Ketone Content in Flavoring Substances Tests. The volume of consumed 0.5 N hydrochloric acid should not more than 0.2 mL.

Assay Accurately weigh about 0.5 g of Benzyl Alcohol, and proceed as directed under Method 2 in Alcohol Content in Flavoring Substances Tests.

1 mL of 0.5 N alcoholic potassium hydroxide = 54.07 mg of C₇H₈O

Benzyl Propionate

Chemical Formula: $C_{10}H_{12}O_2$

Molecular Weight: 164.20

Synonyms: Benzyl propanoate

CAS No.: 122-63-4

Compositional Specifications of Benzyl Propionate

Content Benzyl Propionate should contain not less than 98.0% of benzyl propionate ($C_{10}H_{12}O_2$).

Description Benzyl Propionate is a colorless, transparent liquid having a characteristic odor.

Identification To 1 mL of Benzyl Propionate, add 5 mL of 10% ethanolic potassium hydroxide solution. Warm in hot water for 20 minutes. The characteristic odor disappears. Cool, and acidify with diluted sulfuric acid. An odor of propionic acid is evolved.

Purity (1) Specific Gravity : Specific gravity of Benzyl Propionate should be within a range of 1.032 ~ 1.036.

(2) Refractive Index : Refractive Index n_D^{20} of Benzyl Propionate should be within a range of 1.496 ~ 1.500.

(3) Clarity and Color of Solution : 1 mL of Benzyl Propionate is dissolved in 3 mL of 70% ethanol. This solution should be Clear.

(4) Acid Value : Acid value of Benzyl Propionate is tested by Acid Value in Flavoring Substance Test. It should not be more than 1.

(5) Chlorinated Compounds : Proceed as directed under Copper Mesh Method in Halogen Tests in Flavoring Substances Tests. It should be appropriate.

Assay Accurately weigh about 1 g of Benzyl Propionate, and proceed as directed under Ester Value and Ester Content in Flavoring Substances Tests.

1 mL of 0.5 N alcoholic solution of potassium hydroxide = 82.10 mg of $C_{10}H_{12}O_2$

Berries Color

INS No.: 163

Definition This is a collective name for pigments which is originated from berries. Major component of this pigment is anthocyanin which is obtained from juice or water extract of berries. There are gooseberry color (origin : Cucumis myriocarpus NAUO), European dewberry color (origin : Rubus caesius L. etc), Raspberry color (origin:Rubus idaeus L. etc.), American red raspberry color (origin : Rubus strigosus MICHX), Red currant color (origin : Ribes sativum SYME.), Loganberry color (origin : Rubus loganobaccus BAILEY), Mulberry color (origin : Morus nigra L., M. alba L), Blackberry color (origin : Rubus fruticosus L), Black currant color (origin : Ribes nigrum L), Black huckleberry color (origin : Gaylussacia baccata C. KOCH.), Blueberry color (origin : Vaccinium corymbosum L), Salmonberry color (origin : Rubus spectabilis PURSH.), Strawberry color (origin : Fragaria ananassa DUCHESNE.), Elder berry color (origin : Sambucus caerulea RAFIN, etc.), Uguisukagura color (origin : Lonicera carulea L. var. emphyllocalyx NAKAI), Whortleberry color (origin : Vaccinium myrtillus L), Cowberry color (origin : Vaccinium Vitis Idaeae L), Cranberry color (origin : Oxycoccus macrocarpus PERS.), Thimbleberry color (origin : Rubus occidentalis L). Dilutant, stabilizer, or solvent can be added for the purpose of color value adjustment and quality preservation.

Compositional Specifications of Berries Color

Content Color value ($E_{1cm}^{10\%}$) of Berries Color should not be less than the indicated value.

Description Berries Color is dark red liquid, lump, powder, or paste with a slight characteristic scent.

Identification (1) Test Solution obtained in Color Value section of Berries Color shows red ~ dark blue color and a maximum absorption at 500 ~ 540 nm.

(2) When Test Solution in (1) is alkalinized by adding sodium hydroxide TS, the color of the solution changes.

Purity (1) Arsenic : It should be no more than 4.0 ppm tested by Arsenic Limit Test.

(2) Lead : When 5.0 g of Berries Color is tested by Atomic Absorption Spectrophotometry or Inductively Coupled Plasma Emission Spectroscopy, its content should not be more than 10.0 ppm.

(3) Sulfur Dioxide : When Berries Color is tested by Purity (3) for 「Grape Skin Extract」, the content should not be more than 0.005% per 1 color value ($E_{1cm}^{10\%}$).

(4) Residual Solvent : When berries color is tested by Purity (5) for 「Paprika Extract Pigments」, residual methanol should not be more than 0.1%(based on the product whose color value is 40).

Assay (Color Value) Appropriate amount of Berries Color is accurately weighed so that the absorbance is within 0.3 ~ 0.7 and dissolved in citric acid-dibasic sodium phosphate buffer solution with pH 3.0 so that total volume is 100 mL (Test Solution). If necessary, the solution is centrifuged and the supernatant

is used. Using citric acid-dibasic sodium phosphate buffer solution with pH 3.0 as a reference solution, absorption A is measured at a wavelength of maximum absorption at 500 ~ 540 nm with 1 cm path length. Color value is obtained using the following equation.

$$\text{Color Value} \left(\frac{E_{1\text{cm}}^{10\%}}{1} \right) = \frac{A \times 10}{\text{weight of the sample(g)}}$$

Citric acid-dibasic sodium phosphate buffer solution (pH 3.0)

- Solution 1 : 0.1 M citric acid solution : 1 l of solution containing 21.01 g of citric acid ($\text{C}_6\text{H}_8\text{O}_7 \cdot \text{H}_2\text{O}$).
- Solution 2 : 0.2 M dibasic sodium phosphate solution : 1 l of solution containing 71.63 g of dibasic sodium phosphate ($\text{Na}_2\text{HPO}_4 \cdot 12\text{H}_2\text{O}$).

Solution 1 and Solution 2 are mixed well (59 : 41) and its pH is adjusted to 3.0.

Betaine

Definition Betaine is obtained by purifying Mulyeots(sugar solutions and syrups) (by separation) from beet (*Beta vulgaris* L. var. *rapa*) of Chenopodiaceae. The major component is betaine ($C_5H_{11}NO_2 = 117.15$).

Compositional Specifications of Betaine

Content Betaine contains 98.0~102.0% of betaine ($C_5H_{11}NO_2$).

Description Betaine is white crystallite with a slight odor and sweet taste.

Identification 10 $\mu\ell$ each of aqueous solution (1→100) of Betaine and Betaine standard solution (1→100) is tested by liquid chromatography as following operation conditions. The retention times for Test Solution and Standard Solution should be identical.

Operation Conditions

- Detector : Differential refractometer(RI Detector)
- Column : Carbohydrate(8 mm×300 mm) or equivalent
- Column Temperature : 80°C
- Mobile Phase : Water
- Flow Rate : 1 mL/min

Purity (1) Clarity of solution : 1 g of Betaine is dissolved in 10 mL of water. The solution should be colorless and clear.

(2) pH : pH of Betaine solution(1→20) should be 5.0~7.0.

(3) Chloride : When 1 g of Betaine is tested as directed under Chlorides Test, the content should not be more than that amount corresponds to 0.15 mL of 0.01 N hydrochloric acid.

(4) Sulfate : When 1 g of Betaine is tested as directed under Sulfates Test, the content should not be more than that amount corresponds to 0.2 mL of 0.01 N sulfuric acid.

(5) Arsenic : It should be no more than 4.0 ppm tested by Arsenic Limit Test.

(6) Lead : When 5.0 g of Betaine is tested by Atomic Absorption Spectrophotometry or Inductively Coupled Plasma Emission Spectroscopy, its content should not be more than 2.0 ppm.

Loss on Drying When Betaine is dried for 3 hours at 105°C, the weight loss should not be more than 2%.

Residue on Ignition Residue on ignition should not be more than 0.1%.

Assay Approximately 1 g of Betaine, previously dried, accurately weighed and dissolved in water to make volume 100 mL. 10 mL of this solution is passed through a column packed with 10 mL of ion exchange resin A mixture of weakly acidic ion exchange resin (H type) and strongly alkaline ion exchange resin (OH type) in 1 : 4 volume ratio. The column is washed by water. Washing water is added to the effluent, which is acidified to pH 1.0 with hydrochloric acid. The total volume is brought up to 100 mL with water.

To 5 mL of this solution, 5 mL of Reinecke salt solution, previously cooled, is added, which is cooled for 3 hours in a refrigerator. Precipitates are filtered through a glass filter (3G4), washed with ether and dried in air. The resultant precipitates are dissolved in 70% acetone so that the total volume is 25 mL, Test Solution. Absorbance of the Test Solution is measured at 525 nm with 1cm path length. Separately, approximately 1g of Betaine Standard, previously dried at 105°C for 3 hours, accurately weighed, and dissolved in water so that the total volume is 100 mL, Standard Stock Solution. 10 mL and 20 mL of this solution are taken. pH of each solution is adjusted to 1.0 with hydrochloric acid and the total volume is brought up to 100 mL with water, Standard Solutions. 5 mL of each Standard Solution is precipitated following the same procedure as the Test Solution. The precipitates are dissolved in 70% acetone and absorption is measured as the Test Solution. A calibration curve is prepared. Using the calibration curve and the absorbance of the Test Solution, the content of betaine is calculated from the following equation.

$$\text{Content(\%)} = \frac{\text{Amount of betaine obtained from calibration curve(\%)}}{\text{weight of the sample(g)}} \times 100$$

Test Solutions

- Reinecke Solution : 1.5 g of Reinecke salt is dissolved in water. pH is adjusted to 1.0 with hydrochloric acid and the total volume is brought up to 100 mL with water.

Biotin



Chemical Formula: $C_{10}H_{16}N_2O_3S$

Molecular Weight: 224.31

CAS No.: 58-85-5

Compositional Specifications of Biotin

Content Biotin should contain not less than 97.5% of biotin ($C_{10}H_{16}N_2O_3S$).

Description Biotin is white crystalline power. It is odorless and has no taste.

Identification The saturated solution of Biotin is prepared using hot water. Upon drop-wise adding the solution, bromine standard solution gets decolorized.

Purity (1) Arsenic : It should be no more than 4.0 ppm tested by Arsenic Limit Test.

(2) Lead : When 5.0 g of Biotin is tested by Atomic Absorption Spectrophotometry or Inductively Coupled Plasma Emission Spectroscopy, its content should not be more than 2.0 ppm.

(3) Melting Point : Melting point of Biotin should be within a range of 229~232°C

(4) Specific Rotation : To 500 mg of Biotin, add 0.1 N sodium hydroxide solution to make 25 mL. The optical rotation of this solution should be within a range of $[\alpha]_D^{25} = +89 \sim +93^\circ$.

(5) Biotin-like substances: Dissolve 0.1 g of Biotin, accurately weighed, in ammonia solution(7→100), and make to 10 mL, Test Solution. To 1 mL of the test solution, add ammonia solution(7→100), and make to exactly 500 mL, Standard Solution. Each 5 μ l of Test solution and Reference solution is tested by thin layer chromatography. When the solvent is developed up to 10 cm from base line, stop developing. After doing air-dry the plate at 105°C for 30 minutes, p-dimethylaminocinnamaldehyde-ethanol solution(1→500)/sulfuric acid-ethanol solution(1→50) is equally nebulized. The spot except for a major red spot which is obtained from the test solution should not thicker than a spot(this spot is obtained from the reference solution). However, a supporting material of thin layer plate, which is prepared by using silica gel for thin layer chromatography is used as the dried thing at 110°C for 1 hour.

Assay Dissolve 500 mg of Biotin, precisely weighed, in 100 mL of water, add phenolphthalein indicator, heat and continuously shake and titrate with 0.1 N sodium hydroxide solution until the color of the solution becomes pink.

1 mL of 0.1 N sodium hydroxide solution = 24.43 mg $C_{10}H_{16}N_2O_3S$

Black carrot extract

Synonyms: Black carrot color

INS No.: 163(vi)

Definition Black carrot extract is a pigment obtained from extracting roots of umbelliferous carrot (*Daucus carota* L. ssp. *sativus* var. *atrorubens* Alef.) with water, slightly acidic or acidic aqueous solution, or ethyl alcohol. The major component is anthocyanins. Dilutant, stabilizer, or solvent can be added for the purpose of color value adjustment and quality preservation.

Compositional Specifications of Black carrot extract

Content Color value ($E_{1cm}^{10\%}$) of Black carrot extract should not be more than the indicated value.

Description Black carrot extract is dark reddish liquid, lump, powder, or paste with a slight characteristic odor.

Identification Test Solution of Black carrot extract obtained in Color Value section shows red~deep blue-black and a absorbance maximum is at 500~550 nm.

Purity (1) Arsenic : It should be no more than 4.0 ppm tested by Arsenic Limit Test.

(2) Lead : When 5.0 g of Black carrot extract is tested by Atomic Absorption Spectrophotometry or Inductively Coupled Plasma Emission Spectroscopy, its content should not be more than 2.0 ppm.

(3) Cadmium : When 5.0 g of Black carrot extract is tested by Atomic Absorption Spectrophotometry or Inductively Coupled Plasma Emission Spectroscopy, its content should not be more than 1.0 ppm.

(4) Mercury : When 0.1 g of Black carrot extract is tested by Mercury Test Method, its content should not be more than 1.0ppm.

(5) Sulfur dioxide : When Black carrot extract is tested by the purity test (3) of Grape Skin Extract, the amount of sulfur dioxide should be less them 0.005% in 1 Color value ($E_{1cm}^{10\%}$)

Assay(color value) Appropriate amount of Black carrot extract is accurately weighed so that the absorption is within the range of 0.3 to 0.7 and dissolved in citric acid-disodium phosphate buffer solution with pH 3.0 to make 100 mL. If necessary, centrifuge and use the supernatant. Using citric acid-disodium phosphate buffer solution with pH 3.0 as a blank, absorbance A is measured at the maximum absorption at 500~550 nm with 1 cm path length. Color value is obtained using the following equation.

$$\text{Color Value}(\mathbf{E}_{1cm}^{10\%}) = \frac{A \times 10}{\text{weight of the sample(g)}}$$

• citric acid · disodium phosphate buffer solution (pH 3.0)

Solution 1(0.1M citric acid solution) : 1 L of solution contains 21.01 g of citric acid($C_6H_8O_7 \cdot H_2O$)

Solution 2(0.2M disodium phosphate solution) : 1 L of solution contains 71.63g of disodium phosphate($\text{Na}_2\text{HPO}_4 \cdot 12\text{H}_2\text{O}$)

Solution 1 and Solution 2 are mixed well (59:41) and its pH is adjusted to 3.0.

Branching glycosyltransferase

1,4- α -Glucan Branching Enzyme

Definition Branching glycosyltransferase is an enzyme obtained from cultures of *Bacillus subtilis* in which the branching glycosyltransferase gene of *Rhodothermus obamensis* is inserted. Dilutant or stabilizer can be added for the purpose of activity adjustment and quality preservation.

This Branching glycosyltransferase transforms α -1,4-glycoside combination of amylose to β -1,6-glycoside combination at the unreduced terminal.

Compositional Specifications of Cellulase

Description Branching glycosyltransferase is white ~ deep brown powder, particle, paste or colorless ~ deep brown liquid.

Identification When Branching glycosyltransferase is proceeded as directed under Activity Test, it should have the activity as Branching glycosyltransferase.

Purity (1) Arsenic : It should be no more than 4.0 ppm tested by Arsenic Limit Test.

(2) Lead : When 5.0 g of Branching glycosyltransferase is tested by Atomic Absorption Spectrophotometry or Inductively Coupled Plasma Emission Spectroscopy, its content should not be more than 5.0 ppm.

(3) Coliform Group : Branching glycosyltransferase is tested by Microbe Test Methods for Coliform Group in General Test Methods in 「Standards and Specifications for Foods」. It should not be more than 30 cfu per 1 g of this product.

(4) Salmonella : Branching glycosyltransferase is tested by Microbe Test Methods for Salmonella in General Test Methods in 「Standards and Specifications for Foods」. It should be negative (-).

(5) E. Coli : When Branching glycosyltransferase is tested by Microbe Test Methods for E. Coli in General Test Method 「Standards and Specifications for Foods」, it should be negative (-).

Activity Test (activity)

- Analysis Principle : Activity test is calculated by measuring the rate at which the 1-6- α bond is produced in the amylose substrate. The enzyme activity is labelled with Branching Enzyme Units(BEU). 1 BEU is based on measuring absorption of amylose-iodine complex at 660nm after operating test condition to given standard condition(pH 7.2, 60°C).
- Preparation of Test Solution : Take approximately 1 g(\pm 0.5 mg) of enzyme and 80 mL of Tris-HCL buffer to the beaker to dissolve enzyme completely by slowly mixing for 30 minutes. Transfer the solution to the 100 mL flask and add Tris-HCL buffer to dilute. And set the enzyme activity of the diluted test solution within 30~50 BEU/mL. Calculate the dilution rate(D) and use it for the activity calculation(Usually dilution factor is in the range of 10~40). Use the test solution made on that testing day.
- Test Procedure : Each solutions put together to the test tube(Prepare this to use as 4 times repetition). The test solution is mixed with 50 μ L of the test solution($V_s=0.050$ mL) and 50 μ L of substrate solution. The control solution is mixed 50 μ L of water and 50 μ L of substrate solution. Blank test solution is

prepared with 100 µL of water. Each prepared solutions in test tube are mixed well and are allowed to react for 30 minutes at 60°C. After 30 minutes of reaction time, add 2 mL of stop reagent to each test tubes, respectively, and after mixing, allow to stand at room temperature for 20 minutes to stabilize the color. Measure the absorbtion at 660 nm. This is repeated for 4 times and calculate the average absorbtion(A_s : average absorbtion of enzyme test solution. A_R : average absorbtion of control solution, A_B : average absorbtion of blank test solution).

※ The absorbtion of enzyme test solution should be 0.15~0.3. If not, it should be re-measured by adjusting dilution of test solution with 0.1M Tris-HCl(pH 7.2) buffer.

Activity of the enzyme is measured by the following calculating formula.

$$\text{Activity(BEU/g)} = \frac{(A_R - A_s) \times V \times D \times 100}{(A_R - A_B) \times t \times V_s \times W}$$

$(A_R - A_s)$: Absorbtion difference between control and enzyme test solutions

$(A_R - A_B)$: Absorbtion difference between control and blank solutions

V : Minor voloum of enzyme test solution

D : Dilution rate

100 : Conversion factor for labelling enzyme activity unit as BEU/g

t : Reaction time(min.)

V_s : Volume of Enzyme testing solution which is used in test operation(mL)

W : Weight of sample(g)

• Definition of Activity : Branching Enzyme Units(BEU) is defined as the amount of enzyme that results in a reduction of 1% per minute when measuring the absorbtion of amylose-iodine complex at 660nm after operating test condition under the given condition(pH 7.2, 60°C).

Butane

Chemical Formula: C₄H₁₀

Molecular Weight: 58.12

Synonyms: n-Butane

INS No.: 943a

CAS No.: 106-97-8

Content Butane should contain more than 97.0% of n-Butane(C₄H₁₀).

Description Butane is colorless combustible gas with a scent of its own.

Identification To test identification and purity of Butane, stainless specimen cylinder, which is equipped with stainless steel valves and have performance of 200 mL capacity and pressure exceeding 240 psi, is used. First, on condition that the valve remain open, dry cylinder for 2 hours at 110°C and then discharge the air to make the pressure of cylinder under 1 mmHg. After closing the valve, cool the cylinder and measure the weight of cylinder. One end of sample cylinder is tightly connected and the other is loosely connected. Open carefully sample cylinder and sample is discharged throughout loosely connected part. If large amount of sample is discharged, it should be careful because ice crystal may form on inlet and connected part. After connecting to specimen cylinder tightly, open the valve and make sample flow on cylinder being vacuum condition. The sample for test needed is injected into cylinder and the valve of cylinder is closed. Specimen cylinder contained Butane is weighed again and calculated the content injected sample. At this point, it should be careful not to over-inject sample.

(1) When Butane is tested according to Infrared Spectrophotometry, it has absorption bands near the 3.4 μm(vs), 6.8 μm(s), 7.2 μm(m) and 10.4 μm(m).

(2) When steam pressure of Butane is measured with pressure gauges, the pressure is 31 psi at 21°C.

Purity (1) Sulfur Compounds : Open carefully valve of the cylinder contained Butane. When experimenter smell it being careful not to directly reach his face, it doesn't smell of sulfur compound.

$$\text{Content of Butane(\%)} = \frac{\text{Peak area of sample}}{\text{Sum of all the peak area on the chromatogram}} \times 100$$

Assay Sample cylinder, which have the valve with and adjustable flow velocity, containing Butane is connected to chromatography. The liquid sample is discharged through sampling valve. Be careful not to entrap gas or air in valve. After Butane is injected into gas chromatography, gas chromatography is performed with the following operating conditions. The content of Butane is obtained by the following equation and it should be more than 97.0%.

Operation condition

Column : Aluminium 3 mm × 6 m

Filler : Crushed fire brick supporting material containing 10 % tetraethylene glycol dimethyl ether

(GasChrom R or its equivalent)

Carrier gas : Helium [99.995%(v/v)]

Flow velocity : Thermal conductivity detector (TCD)

Column temperature : 33°C

The amount of injection : 2 µL

Note : Butane is combustible and explosive gas. When handling it for test, experimenter must handle it inside a fume hood.

Storage Standard of Butane

Butane should be stored in a light shielded well-closed container in a cold dark place.

Butyl Acetate

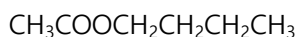

Chemical Formula: $\text{C}_6\text{H}_{12}\text{O}_2$

Molecular Weight: 116.16

Synonyms: Butyl ethanoate

CAS No.: 123-86-4

Compositional Specifications of Butyl Acetate

Content Butyl Acetate should contain not less than 98.0% of butyl acetate ($\text{C}_6\text{H}_{12}\text{O}_2$).

Description Butyl Acetate is a colorless, transparent liquid having a characteristic odor.

Identification To 1 mL of Butyl Acetate, add 5 mL of 10% alcoholic solution of potassium hydroxide. Heat in a water bath. The characteristic odor disappears, and an odor of n-butanol is evolved. Cool, and add 10 mL of water and 0.5 mL of diluted hydrochloric acid (1→3). The solution responds to the test for Acetate (C) in Identification.

Purity (1) Specific Gravity : Specific gravity of Butyl Acetate should be within a range of 0.876 ~ 0.880.

(2) Refractive Index : Refractive Index n_D^{20} of Butyl Acetate should be within a range of 1.393 ~ 1.395.

(3) Clarity and Color of Solution : When 2 mL of Butyl Acetate is dissolved in 4 mL of 70% alcohol, the solution should be clear.

(4) Acid Value : Acid value of Butyl Acetate is tested by Acid Value in Flavoring Substance Test. The content should not be more than 1.0.

Assay Accurately weigh about 0.5 g of Butyl Acetate, and proceed as directed under Ester Value and Ester Content in Flavoring Substances Tests.

1 mL of 0.5 N alcoholic solution of potassium hydroxide = 58.08 mg of $\text{C}_6\text{H}_{12}\text{O}_2$

Butyl Butyrate

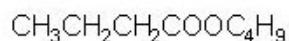

Chemical Formula: $\text{C}_8\text{H}_{16}\text{O}_2$

Molecular Weight: 144.21

Synonyms: Butyl butanoate

CAS No.: 109-21-7

Compositional Specifications of Butyl Butyrate

Content Butyl Butyrate should contain not less than 98.0% of butyl butyrate ($\text{C}_8\text{H}_{16}\text{O}_2$).

Description Butyl Butyrate is a colorless to light yellow, transparent liquid having a fruity odor.

Identification To 1 mL of Butyl Butyrate, add 5 mL of 10% alcoholic solution of potassium hydroxide. When this solution is shaking and heating in a water bath, its characteristic odor disappears, and an odor of n-butanol develops. After cooling, this solution is acidified with dilute sulfuric acid. Then, an odor of butyric acid is generated.

Purity (1) Specific Gravity : Specific gravity of Butyl Butyrate should be within a range of 0.867 ~ 0.871
(2) Refractive Index : Refractive Index n_D^{20} of Butyl Butyrate should be within a range of 1.405 ~ 1.407
(3) Clarity and Color of Solution : When 1 mL of Butyl Butyrate is dissolved in 4 mL of 70% ethanol, the solution should be clear.
(4) Acid Value : Acid value of Butyl Butyrate is tested by Acid Value in Flavoring Substance Test. It should not be more than 1.

Assay Accurately weigh about 1 g of Butyl Butyrate, and test by Ester Value in Flavoring Substances Test.

1 mL of 0.5 N alcoholic potassium hydroxide solution = 72.11 mg $\text{C}_8\text{H}_{16}\text{O}_2$

Butylated Hydroxy Anisole BHA



Chemical Formula: $C_{11}H_{16}O_2$

Molecular Weight: 180.25

Synonyms: BHA

INS No.: 320

CAS No.: 25013-16-5

Compositional Specifications of Butylated Hydroxy Anisole

Description Butylated Hydroxy Anisole occurs as colorless or slightly yellow-brown crystals or lumps or as a white crystalline powder, having a slight characteristic odor and irritating taste.

Identification (1) To 2 ~ 3 mL of solution of Butylated Hydroxyanisole in ethanol (1→100), add 2 ~ 3 drops of sodium borate solution (1→50) and crystals of 2,6-dichloroquinone-chloroimide, and shake. An indigo blue color develops.

(2) Proceed as directed under Identification (2) in 「Butylated Hydroxy Toluene」.

Purity (1) Melting Point : Melting point of Butylated Hydroxy Anisole should be within a range of 57 ~ 65°C

(2) Clarity and Color of Solution : 0.5 g of Butylated Hydroxy Anisole is dissolves in 10 mL of ethanol. The solution should be colorless and clear.

(3) Sulfate : 0.5 g of Butylated Hydroxy Anisole is dissolved in 35 mL of acetone. Add 1 mL of dilute hydrochloric acid and water to make 50 mL. Use this solution as the test solution. Separately, a reference solution is prepared by mixing 0.2 mL of 0.01 N sulfuric acid, 35 mL of acetone, 1 mL of dilute hydrochloric acid, and water to make 50 mL. 2 mL each of barium chloride solution is added to each solution, which is set-aside for 10 minutes. Turbidity of the Test Solution should not be more than that of the reference solution.

(4) Arsenic : It should be no more than 4.0 ppm tested by Arsenic Limit Test.

(5) Lead : When 5.0 g of Butylated Hydroxy Anisole is tested by Atomic Absorption Spectrophotometry or Inductively Coupled Plasma Emission Spectroscopy, its content should not be more than 2.0 ppm.

(6) Mercury : When Butylated Hydroxy Anisole is tested by Mercury Limit Test, its content should not be more than 1.0 ppm.

(7) p-Hydroxyanisole : Dissolve 1 g of Butylated Hydroxy Anisole in 20 mL of an ether.petroleum benziric mixture (1:1), add 10 mL of water and 1 mL of sodium hydroxide solution, shake well, allow to stand,

and collect the lower layer. Add 20 mL of the ether-petroleum benzene mixture (1:1), shake well, allow to stand, collect the lower layer, and add water to make 500 mL. Transfer 1 mL of this solution into a Nestler tube, and add 2 mL of sodium hydroxide solution, 5 mL of boric acid solution (3→100), and water to make 30 mL. Add 5 mL of 4-amino-antipyrine solution (1→1,000), shake, add 1 mL of potassium ferricyanide solution (1→100), shake again, add water to make 50 mL, and allow to stand for 15 minutes. The color of the solution should not be darker than that of a 50 mL solution made by adding water to 0.6 mL of Colorimetric Cobalt(II) Chloride Standard Solution.

Residue on Ignition When thermogravimetric analysis is done with Butylated Hydroxy Anisole, the residue should be not more than 0.05%.

Butylated Hydroxy Toluene

BHT



Chemical Formula: $C_{15}H_{24}O$

Molecular Weight: 220.36

Synonyms: BHT

INS No.: 321

CAS No.: 128-37-0

Compositional Specifications of Butylated Hydroxy Toluene

Description Butylated Hydroxy Toluene occurs as colorless crystals or as white crystalline powder or lumps. It is odorless or has a slight characteristic odor.

Identification (1) To 5 mg of Butylated Hydroxy Toluene, add 1 ~ 2 drops of 5-nitroso-8-hydroxyquinoline sulfuric acid solution (1→100). As it dissolves, a yellow color develops, after which it changes to a red-brown color.

(2) To 1 mL of Butylated Hydroxy Toluene in alcoholic solution (1→30), add 3 ~ 4 drops of ferric chloride solution, no color develops. Add α, α' -dipyridyl crystals. A red color develops. In the case, use a ferric chloride solution which produces no color in a blank test.

Purity (1) Melting Point : Melting point of Butylated Hydroxy Toluene should be within a range of 69 ~ 72°C.

(2) Clarity and Color of Solution : When 1 g of Butylated Hydroxy Toluene is dissolved in 10 mL of ethanol, the solution should be colorless and clear.

(3) Sulfate : To 0.5 g of Butylated Hydroxy Toluene, add 30 mL of water, heat in a water bath for 5 minutes while shaking occasionally, cool and filter. To the filtrate, add 1 mL of dilute hydrochloric acid, Test Solution. Test Solution is tested by Sulfate Limit Test, its content should not be more than the amount that corresponds to 0.2 mL of 0.01 N sulfuric acid.

(4) Arsenic : It should be no more than 4.0 ppm tested by Arsenic Limit Test.

(5) Lead : When 5.0 g of Butylated Hydroxy Toluene is tested by Atomic Absorption Spectrophotometry or Inductively Coupled Plasma Emission Spectroscopy, its content should not be more than 2.0 ppm.

(6) Mercury : When Butylated Hydroxy Toluene is tested by Mercury Limit Test, its content should not be more than 1.0 ppm.

(7) p-Cresol : To 1 g of Butylated Hydroxy Toluene, add 10 mL of water and 1 mL of ammonia water, heat in a water bath for 3 minutes while shaking occasionally, cool and filter. Wash the residue on the filter paper with a small amount of water, combine the washings and the filtrate, and add water to make 100 mL, Test Solution. Take 3 mL of the test solution, transfer into a Nestler tube, add 1 mL of phosphomolybdic acid ethanol (1→20) and 0.2 mL of ammonia solution, and shake. Add water to make 50 mL, and allow to stand for 10 minutes. The color of the solution should not be deeper than that of the solution prepared by the same procedure as the test solution, using 3 mL of p-cresol solution (1→100,000) (Not more than 0.1% as p-cresol).

Residue on Ignition When thermogravimetric analysis is done with Butylated Hydroxy Toluene, the amount of residue should not be more than 0.02%.

***tert*-Butylhydroquinone**

Chemical Formula: C₁₀H₁₄O₂

Molecular Weight: 166.22

INS No.: 319

Synonyms: Mono-*tert*-butylhydroquinone; TBHQ

CAS No.: 1948-33-0

Compositional Specifications of *tert*-Butylhydroquinone

Content *tert*-Butylhydroquinone should contain not less than 99.0% (C₁₀H₁₄O₂).

Description *tert*-Butylhydroquinone:Mono-*tert*-Butylhydroquinone is white crystalline solid with characteristic scent.

Identification Several mg of *tert*-Butylhydroquinone is dissolved in 1 mL of methyl alcohol. When a few drops of 25% dimethylamine solution is added, this solution becomes pink to red.

Purity (1) Arsenic : It should be no more than 4.0 ppm tested by Arsenic Limit Test.

(2) Lead : When 5.0 g of *tert*-Butylhydroquinone is tested by Atomic Absorption Spectrophotometry or Inductively Coupled Plasma Emission Spectroscopy, its content should not be more than 2.0 ppm.

(3) Melting Point : Melting point of *tert*-Butylhydroquinone should be within range of 126.5~128.5°C.

(4) *tert*-Butyl-*p*-Benzonquinone : When proceed as directed under the following procedure, the content should not be more than 0.2%.

◦ Apparatus and Equipment : 0.4 mm calcium fluoride liquid cell and Double Beam Infrared Spectrophotometer.

◦ Preparation of Standard Solution : 10 mg of *tert*-Butylhydroquinone:Mono *tert* Butylhydroquinone is precisely weighed and dissolved in small amount of chloroform, which is then diluted to make 10 mL.

◦ Preparation of Test Solution : *tert*-Butylhydroquinone is ground to fine powder with homogenizer prior to use. 1 g of the ground powder is precisely weighed into a 10 mL volumetric flask and filled with chloroform. The solution is then extracted for 5 minutes and filtered with Millipore filter membrane (UHWP01300) or its equivalent, as the Test Solution.

Test Operation : Chloroform transfer into a reference cell and Standard Solution transfer into a sample cell. Infrared spectrum is recorded in wave numbers of 1,600~1,775 cm⁻¹. A baseline is drawn at 1,612~1,750 cm⁻¹ of this spectrum and the pure absorption of the Standard Solution(As) is obtained at 1,659 cm⁻¹. The pure absorption of the Test Solution (Au) is obtained by the same method. The amount of *tert*-Butylhydroquinone is calculated from the following equation.

$$\text{Content of } \textit{tert}\text{-Butylhydroquinone (\%)} = 100 \times \frac{A_u}{A_s} \times \frac{W_s}{W_u}$$

Ws : weight of standard material (mg)

Wu : weight of sample (mg)

(5) Toluene : 2 g of *tert*-Butylhydroquinone is precisely weighed and dissolved in 10 mL of octyl alcohol, as the Test Solution. 5 µl of each Test Solution and Standard Solution, (prepared as below) is injected into gas chromatography. The content of toluene should not be more than 0.0025%.

Preparation of Standard Solution : 25 mg of toluene is precisely weighed and dissolved in octylalcohol, which is then diluted to make 50 mL. To 10 mL of this solution, octylalcohol is added to make 100 mL.

Operation Conditions

-Column : 3.18 mm x 3.66 m stainless tube

-Column Filler : 60~80 mesh Diatoport S or its equivalent porous support material for gas chromatography is coated with 10% silicon SE-3

-Detector : Hydrogen Flame Ionization Detector (FID)

-Temperature at injection hole : 275°C

-Column Temperature : Temperature is raised from 70°C to 280°C at a rate of 15°C per minute and held at 280°C.

-Detector Temperature : 300°C

-Carrier gas and flow rate : Helium or nitrogen, 50 mL per minute or the flow rate is adjusted so that toluene comes out in approximately 3 minutes.

$$\text{Amount of toluene(\%)} = \frac{\text{peak height of Sa}}{\text{peak height of St}} \times \frac{\text{Concentrate of St (w/v\%)}}{\text{Concentrate of Sa (w/v\%)}} \times 100$$

(6) UV Absorption : 1 g of L-ascorbic acid is dissolved in 200 mL of 50% ethyl alcohol, which is then transferred into a 500 mL separatory funnel (S-1). Approximately 50 g of *tert*-Butylhydroquinone is added to the separatory funnel and dissolved in the solution by shaking. 50 mL of iso-octane is added and extracted for 3 minutes. After settling for 3 minutes, the lower aqueous phase layer is transferred into another 500 mL separatory funnel (S-2). 50 mL of iso-octane is added and extracted again. The lower aqueous phase layer is transferred into another 500 mL separatory funnel (S-3). This solution is again extracted with 50 mL of iso-octane and the aqueous phase layer is discarded. Each iso-octane extract (S-1, S-2, S-3) is mixed with 100 mL of 0.5% ascorbic acid solution in ethyl alcohol · water (ethyl alcohol : water = 25:75), shaken for 1 minute, and extracted. After settling, the lower aqueous layer is discarded. This extraction is repeated again. This iso-octane solution is extracted twice with 100 mL of ethyl alcohol · water (ethyl alcohol : water = 5:95) and aqueous layer is discarded. Finally, iso-octane solution is washed twice with 100 mL of water each and wash water is discarded. Separately, a chromatography column is filled with 100 g of anhydrous sodium sulfate and the column is washed

with 75 mL of iso-octane and the iso-octane is discarded. Iso-octane solution in S-1 is passed through the column and collected in a 500 mL distillation flask. The funnel S-1 is washed with iso-octane solution in S-2. Then the solution is passed through the column and collected in the same distillation flask. The funnel S-2 and S-1 are washed serially with iso-octane solution in S-3. Then the solution is passed through the column and collected in the same distillation flask. S-3, S-2, and S-1 are washed serially with 25 mL of iso-octane twice. This is again passed through the column and collected in the same distillation flask and the column is removed. Add two glass balls and 2 mL hexadecane to a 500 mL distillation flask containing iso-octane residue solution and connect it to an appropriate vacuum distillation apparatus. While the distillation flask is immersed in a water bath, iso-octane is distilled from the solution under 1/3 of atmospheric pressure. When the iso-octane solvent is no longer collected in the solvent receptor, cancel decompression and wash the inner wall of the distillation apparatus from the top with 5 mL of iso-octane. This is again distilled within 1 minute under 1/3 atmospheric pressure. When the distillation is almost complete, this procedure is repeated with 5 mL of iso-octane. Using iso-octane, the residue in the distillation flask is transferred into a 10 mL volumetric flask, which is filled with iso-octane and shaken, use as Test Solution. Using reference solution is prepared with iso-octane, following the same procedures the sample, absorption spectrum is obtained in a wavelength range of 250 nm ~ 400 nm using silica gel cell with 5 cm path length. Maximum absorption for test solution and reference solution at (a) 280~289 nm, (b) 290~299 nm, (c) 300~359 nm, (d) 360~400 nm is measured. Maximum absorption per 1 cm path length is obtained by subtracting absorption of the reference solution from absorption of the test solution. The difference should not exceed (a) 0.15, (b) 0.12, (c) 0.08, (d) 0.02, respectively.

(7) 2,5-di-*tert*-butylhydroquinone and hydroquinone : When proceed as directed under the method, the content of 2,5-di-tertiarybutylhydroquinone and hydroquinone should not be more than 0.2% and 0.1% respectively.

- Preparation of Standard Solution : Approximately 50 mg of hydroquinone, 2,5-di-*tert*-butylhydroquinone and methyl benzoate(internal standard) is accurately weighed and dissolved in pyridine and to make 50 mL, respectively.
- Preparation of Standard Solution for Calibration Curve and Calibration Curve : 0.5, 1.0, 2.0, 3.0 mL of hydroquinone standard solution is taken into each of 10 mL volumetric flasks, respectively. 2 mL of methyl benzoate internal standard solution is added to each flask, which is then to make 10 mL with pyridine. Separately, standard solutions of 2,5-di-tertiarybutylhydroquinone for calibration curve are prepared by the same procedure and Trimethylsilyl derivative of the calibration curve solution prepared as follows. 9 drops of the calibration curve solution are added to a 2 mL serum vial and a cap is placed. The pressure of the vial is reduced with a 50 mL gas syringe. 250 μ L of N,O-bis-trimethylsilyl acetamide is added to the vial, which is then heated for 10 minutes at 80°C. 10 μ L of each test solution for the calibration curve is injected into gas chromatography twice. A calibration curve is prepared by using a concentration ratio of hydroquinone vs. internal standard as a horizontal

axis and a reaction (peak) ratio of hydroquinone vs. internal standard as a vertical axis. Separately, a calibration curve for 2,5-di-tertiarybutylhydroquinone following the same procedure.

- Preparation of Test Solution : Approximately 1 g of *tert*-Butylhydroquinone : Mono-*tert*-Butylhydroquinone is accurately weighed into a 10 mL volumetric flask. 2 mL of methyl benzoate internal standard solution is added to the flask, and to make 10 mL with pyridine. Trimethylsilyl derivative is prepared as described for the Standard Solution above. 10 µl of this solution is injected into gas chromatography twice. Keeping time (in minutes) for methyl benzoate, trimethylsilyl derivative of hydroquinone, trimethylsilyl derivative of *tert*-butylhydroquinone, and trimethylsilyl derivative of 2,5-di-*tert*-butylhydroquinone is 2.5, 5.5, 7.3, and 8.4, respectively. Each peak area is measured, which is used to calculate the reaction ratio of hydroquinone and 2,5-di-*tert*-butylhydroquinone vs. internal standard. The concentration of hydroquinone and 2,5-di-*tert*-butylhydroquinone vs. internal standard is calculated from the calibration curve. Finally the contents (%) of hydroquinone and 2,5-di-*tert*-butylhydroquinone are calculated from the following equation

Operation Conditions

- Column : 6.35 mm × 0.6 m stainless tube
- Column Filler : 60~80 mesh Diatoport S or its equivalent porous support material for gas chromatography is coated with 20% silicon SE-30
- Detector : Thermal conductivity Detector (TCD)
- Temperature at injection hole : 300°C
- Column Temperature : Temperature is raised from 100°C to 270°C at a rate of 15°C per minute and held at 270°C.
- Detector Temperature : 300°C
- Carrier gas and flow rate : Helium or nitrogen, 100 mL per minute.

$$A = Y \times I \times \frac{10}{S}$$

A : The content of hydroquinone or 2,5-di-tertiarybutylhydroquinone in the sample

Y : The concentration ratio of hydroquinone or 2,8-di-tertiarybutylhydroquinone vs. internal standard material, which is obtained from horizontal axis of the calibration curve.

I : The amount of internal standard material in Test Solution (w/v%)

S : weight of sample (g)

Assay

Approximately 170 mg of *tert*-butylhydroquinone, previously powdered and precisely weighed, is dissolved in 10 mL of methyl alcohol and 150 mL of water, 1 mL of 1 N sulfuric acid, and 4 drops of diphenylamine solution (300 mg of sodium p-diphenyl amine sulfonate is dissolved in 100 mL of 0.1 N sulfuric acid.). The resulting solution is titrated with 0.1 N cerium (II) sulfate solution. The end point is

where the solution color becomes yellow to reddish violet. The amount of 0.1 N cerium (II) sulfate solution consumed in mL is V. The content of C₁₀H₁₄O₂ (%) in the sample is calculated from the following equation.

$$\text{Content(\%)} = \frac{(V-0.1\text{mL}) \times 0.8311}{\text{Weight of the sample(g)}} - (\text{hydroquinon(\%)} \times 1.51) - (2,5\text{-d-tertiarybutylhydroquinone(\%)} \times 0.75)$$

0.1 mL : The amount of cerium (II) sulfate solution (in mL) consumed by the primary oxide of tertiarybutylhydroquinone that is commonly found in sample.

Butyric Acid

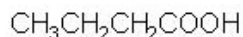

Chemical Formula: $\text{C}_4\text{H}_8\text{O}_2$

Molecular Weight: 88.11

Synonyms: Ethylacetic acid; Butanoic acid

CAS No.: 107-92-6

Compositional Specifications of Butyric Acid

Content Butyric Acid should contain not less than 99.0% of butyric acid ($\text{C}_4\text{H}_8\text{O}_2$).

Description Butyric Acid is a colorless, transparent liquid with a characteristic irritative odor.

Identification (1) To 1 mL of Butyric Acid, add 2 mL of water. The solution is clear and strongly acidic.

(2) To 1 mL of Butyric Acid, add 1 mL of ethanol and 3 drops of sulfuric acid. When the solution is heated in a water bath, an odor of ethyl butyrate is generated.

Purity (1) Specific Gravity: Specific gravity of Butyric Acid should be within a range of 0.952 ~ 0.956.

(2) Refractive Index : Refractive Index n_D^{20} of Butyric Acid should be within a range of 1,397 ~ 1,399.

(3) Sulfate : When 10 g of Butyric Acid is tested by Sulfate Limit Test, its content should not be more than the amount that corresponds to 0.4 mL of 0.01 N sulfuric acid.

Assay Accurately weigh about 1.5 g of butyric acid, and add 75 mL of water, which is then titrated with 0.5 N sodium hydroxide solution (indicator: 2 drops of phenolphthalein solution).

$$1 \text{ mL of } 0.5 \text{ N sodium hydroxide} = 44.06 \text{ mg of } \text{C}_4\text{H}_8\text{O}_2$$

Cacao Color

Definition Cacao Color is a pigment obtained by fermenting and roasting cacao beans of cacao tree (*Theobroma cacao* Linné) of sterculiaceae followed by extracting with water. Its major pigment component is polymer of antocyanin. Dilutant, stabilizer, or solvent can be added for the purpose of color value adjustment and quality preservation.

Compositional Specifications of Cacao Color

Content Color value ($E_{1cm}^{10\%}$) of Cacao Color should be higher than the indicated value.

Description Cacao Color is dark reddish brown liquid, lump, powder, or paste having a slight characteristic odor.

Identification (1) Test Solution obtained in Color Value section appears brown color.

(2) 0.1 g of Cacao Color is dissolved in water to make 100 mL. When 2 ~ 3 drops of hydrochloric acid are added to 5 mL of this solution, reddish brown precipitate is formed.

(3) 0.1 g of Cacao Color is dissolved in water to make 100 mL. When 2 ~ 3 drops of ferric chloride solution are added to 5 mL of this solution, it turns dark brown.

Purity (1) Arsenic : It should be no more than 4.0 ppm tested by Arsenic Limit Test.

(2) Lead : When 5.0 g of Cacao Color is tested by Atomic Absorption Spectrophotometry or Inductively Coupled Plasma Emission Spectroscopy, its content should not be more than 5.0 ppm.

(3) Residual Solvent : When berries color is tested by Purity (5) for 「Paprika Extract Pigments」, residual acetone should not be more than 30 ppm(based on the product whose color value is 50).

Assay (Color Value) Appropriate amount of Cacao Color is precisely weighed so that the absorbance is within 0.3 ~ 0.7 and dissolved in water to make 100 mL. 1 mL of this solution is diluted to 100 mL with citric acid-dibasic sodium phosphate buffer solution with pH 7.0. Use this solution as the test solution. If necessary, the solution is centrifuged and the supernatant is used. Using citric acid-dibasic sodium phosphate buffer solution with pH 7.0 as a reference solution, absorbance A of test solution is measured at 520nm with 1cm cell. Color value is obtained using the following equation.

$$\text{Color Value}(\mathit{E}_{1\text{cm}}^{10\%}) = \frac{A \times 1,000}{\text{weight of the sample(g)}}$$

• Citric acid-dibasic sodium phosphate buffer solution (pH 7.0)

Solution 1 : 0.1M citric acid solution : 1L of solution containing 21.01 g of citric acid ($\text{C}_6\text{H}_8\text{O}_7 \cdot \text{H}_2\text{O}$).

Solution 2 : 0.2M dibasic sodium phosphate solution : 1L of solution containing 71.63 g of dibasic sodium phosphate ($\text{Na}_2\text{HPO}_4 \cdot 12\text{H}_2\text{O}$).

Solution 1 and Solution 2 are mixed well (35:165) and its pH is adjusted to 7.0.

Caffeine

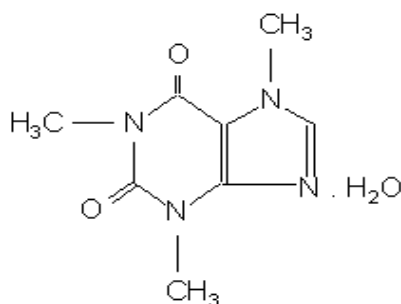

Chemical Formula: $C_8H_{10}N_4O_2 \cdot nH_2O$ ($n = 1$ and 0)

Molecular Weight:

hydrate 212.21, anhydrous 194.19

Synonyms: 1,3,7-Trimethylxanthine, 1,3,7-Trimethylxanthine monohydrate

CAS No.:

58-08-02(anhydrous),

5743-12-4(1 hydrate)

Definition Coffee beans (*Coffea arabica* LINNE) of rubiaceae or tea leaves (*Camellia sinensis* O. KZE) of camellia family are extracted with water or carbon dioxide. The extracts are separated and purified to obtain Caffeine. The major component is caffeine.

Compositional Specifications of Natural Caffeine

Content If Caffeine is converted to an anhydrous form, it should contain 98.5~101.0% of caffeine ($C_8H_{10}N_4O_2$).

Description Caffeine is odorless white crystalline powder having a bitter taste.

Identification (1) When a small amount of tannic acid solution is drop-wise added to 2 mL of aqueous solution (1→500) of Caffeine, white precipitates are formed. When excess amount of this tannic acid is added, the precipitates are dissolved.

(2) 10 drops of hydrogen peroxide solution and 1 drop of hydrochloric acid are added to 0.01 g of Caffeine, which is then evaporated to dryness in a water bath. When the residue is exposed to ammonia gas, it acquires a purple colour. This color disappears when 2 ~ 3 drops of sodium hydroxide solution are added.

(3) 30 mL of 2% aqueous solution of Caffeine is placed in a Nestler tube. When a long wavelength UV lamp is shone from the side and the solution is observed from the top, it should not emit strong violet color. Natural caffeine should show no or slight yellowish green fluorescence.

(4) Theophylline and 8-chlorotheophylline : 0.01 g of Caffeine is dissolved in 5 mL of water, where 3 mL of ammonium chloride buffer solution (pH 8.0) and 1 mL of copper sulfate solution in pyridine are added and mixed. When 5 mL of chloroform is added and shaken, the chloroform phase should not turn green.

Purity (1) Melting Point : Caffeine is dried for 4 hours at 80°C. The melting point of this dried material should be 235~237.5°C.

(2) Arsenic : It should be no more than 4.0 ppm tested by Arsenic Limit Test.

(3) Lead : When 5.0 g of Caffeine is tested by Atomic Absorption Spectrophotometry or Inductively Coupled Plasma Emission Spectroscopy, its content should not be more than 1.0 ppm.

(4) Other Alkaloids : 20 mg of Caffeine is dissolved in 1 mL of water. When 2 ~ 3 drops of Meyer solution are added to this solution, it should not form precipitates.

(5) Readily Carbonizable Substances : 0.5 g of Caffeine is dissolved in 5 mL of sulfuric acid, which is allowed to stand for 15 minutes. When the color of the solution is observed with a white background, the color should not be deeper than that of the color standard D.

(6) Chloride: 2 g of Caffeine is dissolved in 80 mL of hot water and cooled quickly at 20°C. Then add water to make to 100mL and this is used as the test solution. The content should not be more than that amount corresponds to 0.25 mL of 0.01 N hydrochloric acid under Chloride Test. (it should not be more than 0.011%.)

(7) Sulfate : When the test solution 40 mL of Purity (6) is tested for sulfates, the content should not be more than the amount that corresponds to 0.40 mL of 0.01 N sulfuric acid. (it should not be more than 0.024%.)

(8) Caffeine-like substances: 0.1 g of caffeine is weighted and dissolved in 10 mL of Chloroform, which is used as test solution. And then Chloroform is added to 1 mL of test solution to make to 100 mL. Again, take 1 mL of this solution and make to 10 mL, it is used as standard solution. Take 10 $\mu\ell$ of test solution and standard solution, and spot respectively them to the prepared thin layer plate. The mixed solution of Chloroform-95% alcohol solution(9:1) is used as the solvent. When the solvent is developed up to 10 cm from base line, stop developing and air-dry the plate. The plate is observed under a UV light (wavelength 254nm). The spot except for a major spot which is obtained from the test solution should not thicker than a spot(this spot is obtained from the standard solution).

Water Content Water content of Caffeine is determined by direct titration method in water determination (Karl-Fisher Method) and should be 0.5% and 8.5% for anhydrous form and mono hydrated form, respectively.

Residue on Ignition Residue on ignition should not be more than 0.1%.

Assay Approximately 0.4 g of Caffeine is precisely weighed and dissolved in 40 mL of anhydrous acetic acid with warming, and cooled. After 80 mL of acetone is added to the solution, which is then titrated with 0.1 N perchloric acid solution (indicator : 3 drops of crystal violet -acetic acid solution). The end point is where the solution turns from violet to green and finally to yellow. Separately, a blank test is carried out by the same method.

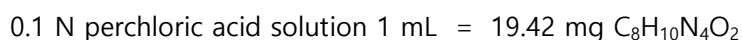

Storage Standard of Natural Caffeine

Caffeine should be stored in a light shielded well-closed container in a cool place.

Calcium Acetate

Chemical Formula: $\text{Ca}(\text{C}_2\text{H}_3\text{O}_2)_2$

INS No.: 263

Molecular Weight: 158.17

CAS No.: 62-54-4

Compositional Specifications of Calcium Acetate

Content Calcium Acetate, when calculated on the dried basis(anhydrous), should contain within a range of 99.0 ~ 100.5% of calcium acetate [$\text{Ca}(\text{C}_2\text{H}_3\text{O}_2)_2$].

Description Calcium Acetate is scentless white powder.

Identification Calcium Acetate solution (1→10) responds to test of calcium salts and acetate salts in Identification.

Purity (1) Chlorides : When 0.5g of Calcium Acetate is tested by Chloride Limit Test, the content should not be more than the amount that correspond to 0.7 mL of 0.01 N hydrochloric acid.

(2) Sulfates : When 0.24 g of Calcium Acetate is tested by Sulfate Limit Test, the content should not be more than the amount that correspond to 0.5 mL of 0.01 N hydrochloric acid.

(3) Fluoride : 1 g of Calcium Acetate is precisely weighed and is tested by purity (8) for 「Calcium Citrate」, its content should not be more than 50 ppm.

(4) Lead : When 5.0 g of Calcium Acetate is tested by Atomic Absorption Spectrophotometry or Inductively Coupled Plasma Emission Spectroscopy, its content should not be more than 2.0 ppm.

(5) Arsenic : It should be no more than 4.0 ppm tested by Arsenic Limit Test.

(6) Mercury : When Calcium Acetate is tested by Mercury Limit Test, its content should not be more than 1.0 ppm.

Water Content Water content of Calcium Acetate is determined by water determination (Karl-Fisher Method) and the content should not be more than 7.0%.

Assay Approximately 0.3 g of Calcium Acetate is dissolved in 150 mL of water which contains 2 mL of dilute hydrochloric acid. While stirring, 30 mL of 0.05 M EDTA solution is added. 15 mL of sodium hydroxide solution and 0.3 g of hydroxy naphthol blue hydroxynaphtholblue ($\text{C}_{20}\text{H}_{12}\text{O}_{11}\text{S}_3\text{Na}_2$) are added to the solution, which is titrated with 0.05 M EDTA solution. The end point is where the red color disappears completely and the color becomes blue.

1 mL of 0.05 M EDTA solution = 7.909 mg $\text{Ca}(\text{C}_2\text{H}_3\text{O}_2)_2$

Calcium Alginate

Chemical Formula: $[(C_6H_7O_6)_2Ca]_n$

Equiv wt, actual(avg.): 219.00

INS No.: 404

Synonyms: Calcium salt of alginate

CAS No.: 9005-35-0

Compositional Specifications of Calcium Alginate

Content Calcium Alginate, when calculated on the dried basis, should contain within a range of 18~21% of carbon dioxide (CO₂), which corresponds to 89.6~104.5% of calcium alginate.

Description Calcium Alginate is almost scentless tasteless white ~ pale yellow fiber, grain, granule, or powder.

Identification Proceed as directed under Identification (3) for [Alginic Acid].

Purity (1) Arsenic : It should be no more than 4.0 ppm tested by Arsenic Limit Test.

(2) Lead : When 5.0 g of Calcium Alginate is tested by Atomic Absorption Spectrophotometry or Inductively Coupled Plasma Emission Spectroscopy, its content should not be more than 5.0 ppm.

(3) Cadmium : When 5.0 g of Calcium Alginate is tested by Atomic Absorption Spectrophotometry or Inductively Coupled Plasma Emission Spectroscopy, its content should not be more than 1.0 ppm.

(4) Mercury : When Calcium Alginate is tested by Mercury Limit Test, its content should not be more than 1.0 ppm.

(5) Total Viable Aerobic Count : When Calcium Alginate is tested by Microbe Test Methods for Total Viable Aerobic Count (Number of General Germs) in General Test Method in 「Standards and Specifications for Foods」, it should not be more than 5,000 per 1 g

(6) E. coli : When Calcium Alginate is tested by Microbe Test Methods for E. coli in General Test Method 「Standards and Specifications for Foods」, it should be negative (-).

(7) Salmonella : When Calcium Alginate is tested by Microbe Test Methods for Salmonella in General Test Method 「Standards and Specifications for Foods」, it should be negative (-).

(8) Fungi : When Calcium Alginate is tested by Microbe Test Methods for Fungi in General Test Method in 「Standards and Specifications for Foods」, it should not be more than 500 per 1 g

Loss on Drying When 3 g of Calcium Alginate is dried for 4 hours at 105°C, the loss should not be more than 15%.

Assay Approximately 0.25 of Calcium Alginate is precisely weighed and analyzed by the procedure in Content Analysis for [Xanthan Gum].

1 mL of 0.25 N sodium hydroxide solution = 27.38 mg calcium alginate
(Equivalent Value : 219.00)

Calcium L-Ascorbate



Chemical Formula: $C_{12}H_{14}CaO_{12} \cdot 2H_2O$

Molecular Weight: 426.34

INS No.: 302

Synonyms: Calcium ascorbate dihydrate

CAS No.: 5743-27-1

Compositional Specifications of Calcium Ascorbate

Content Calcium Ascorbate should contain within a range of 98.0~100.5% of calcium ascorbate($C_{12}H_{14}CaO_{12} \cdot 2H_2O$).

Description Calcium Ascorbate occurs as white ~ pale yellow crystalline powder. It is odorless or has a slightly characteristic odor.

Identification Calcium Ascorbate solution (1→10) responds to the test for Ca^{2+} calcium salts in Identification. Upon adding a solution of 2,6-dichlorophenol indophenol sodium the color disappears.

Purity (1) Specific Rotation : 1 g of Calcium Ascorbate, precisely weighed, is dissolved in water to make 20 mL. Optical rotation of this solution should be within a range of $[\alpha]_D^{25} = +95 \sim +97^\circ$.

(2) Hydroxide Salt : 1 g of Calcium Ascorbate is dissolved in 10 mL of water. 2 drops of glacial acetic acid and 5 mL of calcium acetate solution (1→10) are added to the solution, which is set-aside for 5 minutes. The solution should stay clear.

(3) Fluoride : 1 g of Calcium Ascorbate is precisely weighed and is tested by Purity (8) for 「Calcium Citrate」(not more than 10 ppm).

(4) Arsenic : It should be no more than 4.0 ppm tested by Arsenic Limit Test.

(5) Lead : When 5.0 g of Calcium Ascorbate is tested by Atomic Absorption Spectrophotometry or Inductively Coupled Plasma Emission Spectroscopy, its content should not be more than 2.0 ppm.

(6) Mercury : When Calcium Ascorbate is tested by Mercury Limit Test, its content should not be more than 1.0 ppm.

Assay Approximately 0.3 g of Calcium Ascorbate is precisely weighed and dissolved in 50 mL of water, which is immediately titrated with 0.1N iodine solution. The end point is where pale yellow color persists for 30 seconds.

1 mL of 0.1 N iodine solution = 10.66 mg $C_{12}H_{14}CaO_{12} \cdot 2H_2O$

Calcium Benzoate

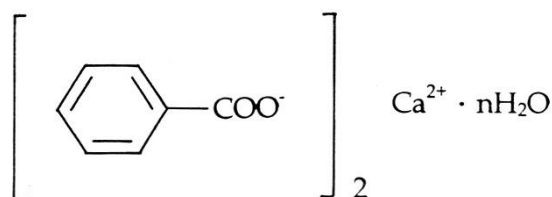

Chemical Formula: $\text{C}_{14}\text{H}_{10}\text{CaO}_4 \cdot n\text{H}_2\text{O}$ ($n = 0, 1$ or 3)

Molecular Weight: trihydrate 336.36

hydrate 300.32

anhydrous 282.31

INS No.: 213

Synonyms: Monocalcium benzoate; Calcium dibenzoate

CAS No.: 2090-05-3

Compositional Specifications of Calcium Benzoate

Content Calcium Benzoate, when calculated on the dried basis, should contain not less than 99.0% of calcium benzoate ($\text{C}_{14}\text{H}_{10}\text{CaO}_4$).

Description Calcium Benzoate is colorless ~ white crystal or powder.

Identification (1) Melting Point : 2% aqueous solution of Calcium Benzoate is acidified with dilute hydrochloric acid. Precipitates are filtered, washed with water, and dried for 4 hours at 105°C . The melting point should be within a range of $121.5\sim 123.5^\circ\text{C}$.

(2) Water Insoluble substances : 10 g of Calcium Benzoate is dissolved in 100 mL of hot water and filtered through a crucible type glass filter (1G4) that is previously weighed. Insoluble substances are washed with hot water and dried along with the filter for 2 hours at 105°C . After cooling in a desiccator, the filter with insoluble substances is weighed. The content of water insoluble substances should not be more than 0.3%.

(3) Free Acid and Free Alkali : 2 g of Calcium Benzoate is precisely weighed and dissolved in 20 mL of hot water. After adding 2 ~ 3 drops of phenolphthalein solution, the solution is titrated with 0.1 N sodium hydroxide solution or 0.1 N of hydrochloric acid. The consumed amount of the solution should not be more than 0.5 mL.

(4) Chlorinated Compounds : 0.25 g of Calcium Benzoate is dissolved in 10 mL of water, which is acidified with nitric acid. The precipitates are filtered, mixed with 0.5 g potassium carbonate, and dried. The mixture is then heat treated for approximately 10 minutes at 600°C . After cooling, the residue is dissolved in 20 mL of diluted nitric acid and filtered. 0.5 mL of 0.1 N silver nitrate is added to the filtrate (Test Solution). Separately, water is added to a mixture of 0.5 mL of 0.1 N silver nitrate solution

and 0.5 mL of 0.01 N hydrochloric acid so that the concentration is the same as in Test Solution (Reference Solution). Turbidity of the Test Solution should not be more than that of the Reference Solution.

- (5) Fluoride : 1 g of Calcium Benzoate is precisely weighed and is tested by purity (8) for 「Calcium Citrate」, its content should not be more than 10 ppm.
- (6) Arsenic : It should be no more than 4.0 ppm tested by Arsenic Limit Test.
- (7) Lead : When 5.0 g of Calcium Benzoate is tested by Atomic Absorption Spectrophotometry or Inductively Coupled Plasma Emission Spectroscopy, its content should not be more than 2.0 ppm.
- (8) Mercury : When Calcium Benzoate is tested by Mercury Limit Test, its content should not be more than 1.0 ppm.
- (9) Readily Oxidizable Matters : Add 1.5 mL of sulfuric acid to 100 mL of water, while boiling, add drop wise 0.1 N potassium benzoate while boiling until the pink color persists for 30 seconds. Weigh 1 g of Calcium Benzoate, and dissolve in the solution. Titrate with 0.1 N potassium permanganate at about 70°C until the pink color persists for 15 seconds. The amount should not be more than 0.5 mL.

Loss on Drying When Calcium Benzoate is dried at 105°C until the weight becomes constant, the loss should not be more than 17.5%.

Assay Dissolve 0.6 g of Calcium Benzoate, previously dried and accurately weighed in 20 mL of water and 2 mL of diluted hydrochloric acid, which is diluted to 100 mL with water. Approximately 30 mL of 0.05 M EDTA solution is added while shaking well. After adding 15 mL of sodium hydroxide solution and 0.25 g of hydroxy naphthol blue, the solution is titrated with 0.05 M EDTA solution.

$$1 \text{ mL of } 0.05 \text{ M EDTA solution} = 14.116 \text{ mg } \text{C}_{14}\text{H}_{10}\text{CaO}_4$$

Calcium Carbonate

Chemical Formula: CaCO₃

INS No.: 170(i)

Molecular Weight: 100.09

CAS No.: 471-34-1

Compositional Specifications of Calcium Carbonate

Content Calcium Carbonate, when calculated on the dried basis, should contain not less than 98.0 % of calcium carbonate(CaCO₃).

Description Calcium Carbonate occurs as a fine white powder. It is odorless.

Identification To 1 g of Calcium Carbonate, add 10 mL of water and 7 mL of diluted acetic acid. It effervesces and dissolves. This solution, after being boiled and neutralized with ammonia solution, it responds to test of Calcium Salt in Identification.

Purity (1) Hydrochloric Acid-Insoluble Substances : To 5.0 g of Calcium Carbonate, add 10 mL of water, and add drop wise gradually 12 mL of hydrochloric acid while stirring, and add water to make 200 mL. Filter through a filter paper for quantitative analysis, wash thoroughly the residue on the filter paper with boiling water until the washings do not respond to the test by Chloride Limit Test, incinerate together with the filter paper, and weigh the residue. The content should not be more than 10 mg.

(2) Free Alkali : To 3.0 g of Calcium Carbonate, add 30 mL of freshly boiled and cooled water, shake for 3 minutes, and filter the solution. Measure 20 mL of the filtrate, and add 2 drops of phenolphthalein solution. Even if a pink color becomes, it disappears when 0.2 mL of 0.1 N hydrochloric acid is added.

(3) Arsenic : It should be no more than 4.0 ppm tested by Arsenic Limit Test.

(4) Lead : Calcium Carbonate is tested by purity (2) for 「Sodium Metaphosphate」(not more than 3.0 ppm).

(5) Cadmium : Calcium Carbonate is tested by purity (3) for 「Sodium Metaphosphate」(not more than 1.0 ppm).

(6) Fluoride : 1 g of Calcium Carbonate is precisely weighed and is tested by purity (8) for 「Calcium Citrate」(not more than 50 ppm).

(7) Alkali Metals and Magnesium : Weigh 1 g of Calcium Carbonate, dissolve by gradually adding 30 mL of 1 N diluted hydrochloric acid, expel carbon dioxide while boiling. Cool, neutralize with ammonia solution, add 60 mL of ammonium oxalate solution , and heat in a water bath for 1 hour. Cool, add water to make 100 mL, stir thoroughly, filter, measure 50 mL of the filtrate, add 0.5 mL of sulfuric acid, evaporate to dryness, and ignite to constant weight, and weigh the residue. Its content should not be more than 5 mg.

(8) Barium : Weigh 1 g of Calcium Carbonate, dissolve in 15 mL of diluted hydrochloric acid, add water to make 30 mL and filter. To the filtrate, add 2 g of sodium acetate, 1 mL of diluted acetic acid and 0.5 mL of potassium chromate solution and allow to stand for 15 minutes. The turbidity of this solution

should be not more than the turbidity of the solution obtained as adding water to 0.3 mL barium standard solution, make 20 mL (not more than 0.03%).

Loss on Drying When Calcium Carbonate is dried for 4 hours at 200°C, the weight loss should not be more than 2%.

Assay Accurately weigh about 1 g of Calcium Carbonate, previously dried, gradually dissolve in 10 mL of diluted hydrochloric acid, gradually added, add water to make exactly 100 mL. Proceed as directed under Assay in 「Calcium Hydroxide」.

1 mL of 0.05 M EDTA = 5.004 mg of CaCO₃

Calcium Carboxymethyl Cellulose

Compositional Specifications of Calcium Carboxymethylcellulose

Description Calcium Carboxymethylcellulose occurs as a white to pale yellow powder or fibrous substance, it is odorless.

Identification (1) To 0.1 g of Calcium Carboxymethylcellulose add 10 mL of water, stir thoroughly, and add 2 mL of sodium hydroxide solution. Shake, allow to stand for 10 minutes, and use this solution as the test solution. Proceed as directed under Identification (1) for 「Sodium Carboxymethylcellulose」.
(2) Dissolve 1 g of the residue on ignition of Calcium Carboxymethylcellulose in 10 mL of water and 5 mL of diluted acetic acid, and filter if necessary. Boil, cool, and neutralize with ammonia solution. The solution responds to the test for Calcium Salt.

Purity (1) Free Alkali : To 1 g of Calcium Carboxymethylcellulose, add 50 mL of freshly boiled and cooled water, shake well, and then add 2 drops of phenolphthalein solution. No pink color develops.
(2) Chloride : To 0.1 g of Calcium Carboxymethylcellulose, add 10 mL of water, stir thoroughly, and add 2 mL of sodium hydroxide solution (1→25). After shaking, allow to stand for 10 minutes, and make the solution strongly acidic with diluted nitric acid (1→10). Add 0.5 mL of hydrogen peroxide, and heat in a water bath for 30 minutes. After cooling, add water to make 100 mL, and filter through a dry filter paper. Measure exactly 20 mL of the filtrate as the test solution. When Calcium Carboxymethylcellulose is tested by Chloride Limit Test, its content should not be more than the amount that corresponds to 0.2 mL of 0.01 N hydrochloric acid.
(3) Sulfate : To 0.1 g of Calcium Carboxymethylcellulose, add 10 mL of water, stir thoroughly, and add 2 mL of sodium hydroxide solution (1→25). After shaking, allow to stand for 10 minutes, and make strongly acidic with diluted hydrochloric acid (1→4). Add 0.5 mL of hydrogen peroxide, and heat in a water bath for 30 minutes. Measure exactly 20 mL of the filtrate as the test solution. When Calcium Carboxymethylcellulose is tested by Sulfate Limit Test, its content should not be more than the amount that corresponds to 0.4 mL of 0.01 N sulfuric acid.
(4) Arsenic : It should be no more than 4.0 ppm tested by Arsenic Limit Test.
(5) Lead : When 5.0 g of Calcium Carboxymethylcellulose is tested by Atomic Absorption Spectrophotometry or Inductively Coupled Plasma Emission Spectroscopy, its content should not be more than 2.0 ppm.

Loss on Drying When Calcium Carboxymethylcellulose is dried for 4 hours at 105°C, the weight loss should not be more than 10%.

Residue on Ignition When thermogravimetric analysis is done with 1 g of dried material, the amount of residues should be within a range of 10 ~ 20%.

Calcium Caseinate

Synonyms: Casein-calcium

CAS No.: 9005-43-0

Compositional Specifications of Calcium Caseinate

Content Calcium Caseinate, when calculated on the dried basis, should contain within a range of 14.5~15.8% of Nitrogen(N=14.01).

Description Calcium Caseinate occurs as white to pale yellow powder, granules, or flakes. It is odorless and tasteless or has a slight, characteristic odor and taste.

Identification (1) Proceed as directed under Identification (1), (2), and (3) in 「Casein」.

(2) The residue on ignition of Calcium Caseinate responds to the test for Calcium Salt in Identification.

Purity (1) Clarity and Color of Solution : Proceed as directed under Purity (1) in 「Casein」. The resulting solution should be colorless and should not be more than turbid.

(2) pH : Calcium Caseinate solution(1→50) should be within a range of pH 6.0 ~ 7.5.

(3) Fat : Proceed as directed under Purity (4) in 「Casein」.(not more than 1.5%)

(4) Arsenic : It should be no more than 4.0 ppm tested by Arsenic Limit Test.

(5) Lead : When 5.0 g of Calcium Caseinate is tested by Atomic Absorption Spectrophotometry or Inductively Coupled Plasma Emission Spectroscopy, its content should not be more than 1.0 ppm.

(6) Lactose : Accurately weigh 1g of Calcium caseinate and put into 150mL-beaker. Add 25mL of water and dissolve it at 60~70°C, then cool down to room temperature. Add 15mL of water, 8mL of 0.1N hydrochloric acid, and 1mL of 10% acetic acid solution and mix well by swirling. After 5 minutes, add 1mL of 1M sodium acetate, and mix well. When the precipitates is settled, filter it and remove the first 5mL of filtrate. Transfer 2mL of the remaining filtrate into a test tube and add 0.2mL of phenol solution. After mixing well, add 5mL of sulfuric acid and mix within 1~2 seconds. Confirm that the solution is completely mixed, and allow it to stand for 15 minutes. Then, cool down to 20°C in a water bath for 5 minutes(Test solution). 1, 2, 3, and 4mL of 2mg/mL lactose standard stock solution is transferred into four separate 500mL-flasks and dilute with water to 500mL to consequently containing 20, 40, 60, and 80µg/mL of lactose. Add 2mL of water and 3mL of standard stock solution into each of five test tubes. Add 0.2mL of phenol solution and mix well. Add 5mL of sulfuric acid and mix well within 1~2 seconds. Confirm that the solution is completely mixed, and allow it to stand for 15 minutes. Then, cool down to 20°C in a water bath for 5 minutes(Standard solution). Measure a absorbance of the standard solution at a wavelength of 490nm using water as a reference and prepare a calibration curve. Prepare the reference solution in the same manner and measure a absorbance of the test solution. The content that is calculated using the following equations should not be more than 2.0%.

$$\text{The content of lactose(\%)} = \frac{A \times 0.00475}{a \times m}$$

A = Absorbance of test solution

a = Extinction coefficient of the lactose standard solution (Slope of a calibration curve)

m = Weight of the sample(g)

Phenol solution : Heat the mixed solution with 8g of phenol and 2g of water, and dissolve until there are no crystals.

Loss on Drying When Calcium Caseinate is dried for 3 hours at 100°C, the weight loss should not be more than 15.0%.

Assay Accurately weigh about 0.15 g of Calcium Caseinate, previously dried, and proceed as directed under Kjeldahl Method in Nitrogen Determination.

1 mL of 0.1 N sulfuric acid = 1.401 mg of N

Calcium Chloride

Chemical Formula: $\text{CaCl}_2 \cdot n\text{H}_2\text{O}$ (n=0 or 2)

INS No.: 509

Molecular Weight: 2 hydrate 147.01
anhydrous 110.98

CAS No.:
10043-52-4(anhydrous)
10035-04-8(2 hydrate)

Compositional Specifications of Calcium Chloride

Content Calcium Chloride should contain not less than 70.0% of calcium chloride ($\text{CaCl}_2 = 110.99$).

Description Calcium Chloride occurs as white crystals, powder, flakes, granules, or lumps. It is odorless.

Identification Calcium Chloride responds to the tests for Calcium Salt and Chloride.

Purity (1) Clarity and Color of Solution : 1 g Calcium Chloride is dissolved in 20 mL of water. The turbidity of resulting solution should show slightly low level of turbid or better.

(2) Free Acid and Free Alkali : Weigh 1 g of Calcium Chloride, dissolve in 20 mL of freshly boiled and cooled water, add 2 drops of phenolphthalein solution, and perform the following test for this solution

① If the solution is colorless, add 2 mL of 0.02 N sodium hydroxide. A pink color develops.

② If the solution is pink, add 2 mL of 0.02 N hydrochloric acid. The color disappears.

(3) Arsenic : It should be no more than 4.0 ppm tested by Arsenic Limit Test.

(4) Lead : Calcium Chloride is tested by purity (2) for 「Sodium Metaphosphate」(not more than 2.0 ppm).

(5) Mercury : When Calcium Chloride is tested by Mercury Limit Test, its content should not be more than 1.0 ppm.

(6) Fluoride : 1 g of Calcium Chloride is precisely weighed and is tested by purity (8) for 「Calcium Citrate」(not more than 40 ppm).

(7) Alkali Metals and Magnesium : Weigh 1 g of Calcium Chloride, dissolve in 50 mL of water, mix with 500 mg of ammonium chloride, and boil for 1 minute. Quickly add 40 mL of oxalic acid solution (3→50), stir vigorously to form a precipitate, immediately add 2 drops of methyl red solution and drop wise ammonia solution to make slightly alkaline, and cool. Transfer the solution into a 100 mL measuring cylinder, add water to make 100 mL, allow to stand for 4 hours to overnight, and filter the supernatant through a dried filter paper. Measure 50 mL of the filtrate, add 0.5 mL of sulfuric acid, evaporate to dryness, ignite to constant weight, and weigh the residue. The residue should not be more than 25 mg (Not more than 5%).

Assay Approximately 5 g of Calcium Chloride is precisely weighed and dissolved in water to make 500 mL. Take 25 mL of this solution, add water to make 100 mL, and add 15 mL of 10% sodium hydroxide solution. After 1 minute, approximately 0.1 g of 2-oxy-1-(2'-oxy-4'-sulfo-1'-naphthylazo)-3-naphthoic acid. It is then immediately titrated with 0.05 M EDTA solution. End point is where the red color of the solution completely disappears and changes to blue.

1 mL of 0.05 M EDTA = 5.550 mg of CaCl₂

Calcium Citrate

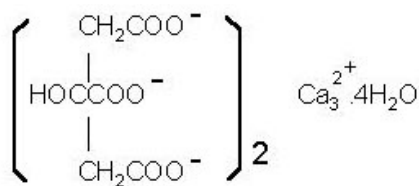

Chemical Formula: $\text{C}_{12}\text{H}_{10}\text{Ca}_3\text{O}_{14} \cdot 4\text{H}_2\text{O}$

Molecular Weight: 570.51

Synonyms: Tricalcium citrate; Tribasic calcium citrate

INS No.: 333(iii)

CAS No.:

813-94-5(anhydrous)

Compositional Specifications of Calcium Citrate

Content Calcium Citrate, when calculated on the dried basis, should contain not less than 97.5% of calcium citrate ($\text{C}_{12}\text{H}_{10}\text{Ca}_3\text{O}_{14} = 498.44$).

Description Calcium Citrate occurs as a white powder. It is odorless.

Identification Calcium Citrate responds to the test for Potassium Salt and Citrate in Identification.

Purity (1) Hydrochloric Acid-Insoluble Substances : To 5 g of Calcium Citrate, add 10 mL of hydrochloric acid and 50 mL of water, and heat in a water bath for 30 minutes. Add water to make 200 mL. and filter through a filter paper for quantitative analysis. Wash the residue on the filter paper thoroughly with boiling water. Reduce to ash together with the filter paper, and weight the residue. The amount of residue should not be more than 3 mg.

(2) pH : Weigh 1 g of Calcium Citrate and dissolve in 20 mL of water, pH of the solution should be within a range of 6.0 ~ 8.0.

(3) Chloride : When 1 g of Calcium Citrate is dissolved in 10 mL of dilute nitric acid by heating, which is tested by Chloride Limit Test, its content should not be more than the amount that corresponds to 0.2 mL of 0.01 N hydrochloric acid.

(4) Sulfate : 1 g of Calcium Citrate is dissolved in 10 mL of dilute hydrochloric acid by heating. After cooling, the solution is tested by Sulfate Limit Test, its content should not be more than the amount that corresponds to 0.5 mL of 0.01 N sulfuric acid.

(5) Arsenic : It should be no more than 4.0 ppm tested by Arsenic Limit Test.

(6) Lead : When 5.0 g of Calcium Citrate is tested by Atomic Absorption Spectrophotometry or Inductively Coupled Plasma Emission Spectroscopy, its content should not be more than 1.0 ppm.

(7) Mercury : When Calcium Citrate is tested by Mercury Limit Test, its content should not be more than 1.0 ppm.

(8) Fluoride : 1 g of Calcium Citrate transfer into a beaker, and dissolve in 10 mL of hydrochloric acid (1→10). Then heat the solution for 1 minute, transfer into a PE(polyethylene) beaker, and immediately cool down. Add 15 mL of Trisodium Citrate Solution (1→4) and 10 mL of Disodium Ethylenediaminetetraacetate solution (1→40) and mix by shaking. Adjust the pH of this solution to 5.4 ~ 5.6 using Hydrochloric acid (1→10) or Sodium Hydroxide Solution (2→5) and dilute to volume of 100 mL with water. Place 50 mL of the solution in a PE(polyethylene) beaker. Then measure electric potential by using fluorine electrode and the obtained content of fluorine from calibration curve should not be more than 30 ppm.

Calibration Curve Preparation : Accurately weigh 2.210 g of sodium fluoride, which is previously dried for 4 hours at 200°C, place it into a PE(polyethylene) beaker and dissolve in 200 mL of water. Then add water to bring the total volume to 1,000mL and preserve it in a PE(polyethylene) beaker. Add 5 mL of this solution into a measuring flask, and add water to bring the total volume to 1,000 mL. (1 mL of this solution contains 5µg of fluorine). Pipet 1, 2, 3, 5, 10, and 15 mL each of this solution respectively into a PE(polyethylene) beaker, and add 15 mL of Trisodium Citrate Solution (1→4) and 10 mL of Disodium Ethylenediaminetetraacetate solution (1→40) and mix. Adjust the pH of this solution to 5.4 ~ 5.6 using dilute Hydrochloric acid (1→10) or Sodium Hydroxide Solution (2→5). To the solution, respectively, add water to bring the total volume to 100mL, Standard Solution. Separately, place 50 mL of the solution in a PE(polyethylene) beaker. Then measure electric potential by using fluorine electrode and prepare calibration curve with the log of fluorine concentration.

Loss on Drying When Calcium Citrate is dried for 4 hours at 150°C, the weight loss should be within a range of 10 ~ 14%.

Assay Dissolve about 1 g of Calcium Citrate, previously dried and accurately weighed, in 10 mL of dilute hydrochloric acid and 10 mL of water, which is diluted to 100 mL with water. Take 25 mL of this solution, and diluted to 100 mL with water, which is neutralized with 10% sodium hydroxide solution. Add 15 mL of 10% sodium hydroxide solution and 20 mL of 0.05 M EDTA solution, it is set-aside for approximately 1 minute. Add 0.1 g of 2-oxy-1-(2'-oxy-4'-sulfo-1-naphtylazo)-3-naphthoic acid, which is titrated with 0.05 M EDTA solution. At the end point, the red color completely disappears and the solution turns blue.

1 mL of 0.05 M EDTA solution = 8.307 mg of $\text{C}_{12}\text{H}_{10}\text{Ca}_3\text{O}_{14}$

Calcium Dihydrogen Pyrophosphate

Chemical Formula: $\text{CaH}_2\text{P}_2\text{O}_7$

Molecular Weight: 215.97

INS No.: 450(vii)

Synonyms: Acid calcium pyrophosphate;
Monocalcium dihydrogen diphosphate

CAS No.: 14886-19-4

Compositional Specifications of Calcium Dihydrogen Pyrophosphate

Content Calcium Dihydrogen Pyrophosphate, when calculated on the dried basis, should contain more than 90.0% of Calcium Dihydrogen Pyrophosphate ($\text{Ca}_2\text{H}_2\text{P}_2\text{O}_7$).

Description Calcium Dihydrogen Pyrophosphate occurs as a white crystalline powder or granular.

Identification (1) 5 mL of acetic acid(1→10) is added to 0.2 g of Calcium dihydrogen pyrophosphate, and dissolve by warming. 2 mL of ammonium molybdate is added to this solution. Upon heating yellow precipitates are formed.

(2) 9 mL of water and 1 mL of hydrochloric acid are added to 0.3 g of Calcium Dihydrogen Pyrophosphate, and dissolved by warming. It is filtered after cooling. When 3 mL of ammonium oxalate solution(1→30) is added, white precipitation occurs. This precipitation is dissolved by adding 5 mL of hydrochloric acid.

Purity (1) Acid Insoluble Substances : 5.0 g of Calcium Dihydrogen Pyrophosphate, accurately weighed, dissolve in 100 of hydrochloric acid(1→4). After leaving it for 1 hours, the acid insoluble substances are filtered by a glass filter (1G4) which met constant weight in advance. After washing the residue with 30 mL of water and the drying for 2 hours at 110°C, the amount of the acid insoluble substances should not be more than 0.4%.

(2) Arsenic : It should be no more than 4.0 ppm tested by Arsenic Limit Test.

(3) Lead : Calcium Dihydrogen Pyrophosphate is tested by purity (2) for 「Sodium Metaphosphate」(not more than 4.0 ppm).

(4) Cadmium : Calcium Dihydrogen Pyrophosphate is tested by purity (3) for 「Sodium Metaphosphate」(not more than 1.0 ppm).

(5) Mercury : When Calcium Dihydrogen Pyrophosphate is tested by Mercury Limit Test, its content should not be more than 1.0 ppm.

(6) Fluoride : 1 g of Calcium Dihydrogen Pyrophosphate precisely weighed, and is tested by purity (8) for 「Calcium Citrate」(not more than 30 ppm).

Loss on Drying When Calcium Dihydrogen Pyrophosphate is dried for 4 hours at 105°C, the weight loss should not be more than 1%.

Assay After drying Calcium Dihydrogen Pyrophosphate, 0.7 g of this accurately was weighed. And add 20 mL of hydrochloric acid(1→4) and boil. After cooling the solution, add water to meet 200 mL as a

test solution. Add 25 mL of 0.02M EDTA to the accurate 20 mL of this test solution. And leaving it for approximate 1 minute 5m after adding 5 mL of water and 5 mL of ammonia-ammonium chloride buffer(pH10.7). Add 0.025 g of Eriochrome black T-sodium chloride indicator and the excess EDTA is titrated with a 0.02M zinc acetate solution. The end point is until blue color of the solution becomes bluish purple. Blank test is performed with same procedure.

1 mL of 0.02M EDTA solution = 4.321 mg $\text{CaH}_2\text{P}_2\text{O}_7$

Storage Standard of Calcium Dihydrogen Pyrophosphate

Calcium Dihydrogen Pyrophosphate should be stored in a dry and cool place.

Calcium Disodium Ethylenediaminetetraacetate



Chemical Formula: $C_{10}H_{12}CaN_2Na_2O_8 \cdot 2H_2O$

Molecular Weight: 410.30

INS No.: 385

Synonyms: Calcium disodium edetate; Calcium disodium EDTA

CAS No.: 62-33-9

Compositional Specifications of Calcium Disodium Ethylenediaminetetraacetate

Content Calcium Disodium Ethylenediaminetetraacetate, when calculated on the anhydrous basis, should contain within a range of 97.0 ~ 102.0% of calcium disodium ethylenediaminetetraacetate ($C_{10}H_{12}CaN_2Na_2O_8 \cdot 2H_2O = 374.27$)

Description Calcium Disodium Ethylenediaminetetraacetate occurs as white to whitish granules or crystalline powder. It is odorless, and has a faint salty taste.

Identification (1) Calcium Disodium Ethylenediaminetetraacetate solution (1→20) responds to the tests for Calcium Salt (B) and Sodium Salt (B) in identification.

(2) Add 2 drops of ammonium thiocyanate solution and 2 drops of ferric chloride solution to 5 mL of water. Into this solution, place 50 mg of Calcium Disodium Ethylenediaminetetraacetate. and shake. The red color of the solution disappears.

Purity (1) pH : pH of Calcium Disodium Ethylenediamine-tetraacetate solution (1→100) should be within a range of 6.5 ~ 7.5.

(2) Arsenic : It should be no more than 4.0 ppm tested by Arsenic Limit Test.

(3) Lead : When 5.0 g of Calcium Disodium Ethylenediaminetetraacetate is tested by Atomic Absorption Spectrophotometry or Inductively Coupled Plasma Emission Spectroscopy, its content should not be more than 2.0 ppm.

(4) Mercury : When Calcium Disodium Ethylenediaminetetraacetate is tested by Mercury Limit Test, its content should not be more than 1.0 ppm.

(5) Magnesium-Chelating Substance : Weigh 1 g of Calcium Disodium Ethylenediaminetetraacetate, dissolve in 5 mL of water, add 5 mL of ammonia.ammonium chloride buffer, and titrate with 0.1 M magnesium acetate (indicator : 5 drops of Eriochrome black T solution). The consumed volume is not more than 2 mL.

Water Content Approximately 0.5 g of Calcium Disodium Ethylenediaminetetraacetate is precisely weighed

and tested by direct titration method of water determination (Karl-Fischer Method). Water content should not be more than 13%.

Assay Accurately weigh about 1.2 ~ 1.5 g of Calcium Disodium Ethylenediaminetetraacetate, transfer into a Erlen Meyer flask, and dissolve in 75 mL of water. 25 mL of dilute acetic acid and 1 mL of diphenylcarbazone solution are added. It is then slowly titrated with 0.1 M mercuric chloride solution until initial purple color appears.

1 mL of 0.1 M mercuricnitrate = 37.43 mg of $C_{10}H_{12}CaH_2Na_2O_8$

Calcium Ferrocyanide

Chemical Formula: $\text{Ca}_2\text{Fe}(\text{CN})_6 \cdot 12\text{H}_2\text{O}$

Molecular Weight: 508.29

INS No.: 538

Synonyms: Hexacyanoferrate of calcium; Yellow prussiate of lime

CAS No.: 1327-39-5

Compositional Specifications of Calcium Ferrocyanide

Content When calcium ferrocyanide is quantified, it should contain not less than 99.0% of calcium ferrocyanide ($\text{Ca}_2\text{Fe}(\text{CN})_6 \cdot 12\text{H}_2\text{O}$)

Description Calcium ferrocyanide is a yellow crystal or crystalline powder.

Identification (1) When 1 mL of ferric chloride is added to 10 mL of calcium ferrocyanide (1→100), a dark blue precipitate are formed.

(2) Calcium ferrocyanide responds to test of calcium salt in the identification method.

Purity (1) Cyanide : 10 mg of copper sulfate is dissolved in 8 mL of water and 2 mL of ammonium solution. A filtering paper is dipped into this solution, to which hydrogen sulfide is then added. When 1 drop of the aqueous solution of this additive (1→100) is dropped on the filtering paper that turned brown, white rings should not appear.

(2) Ferrocyanide : 10 mg of sodium ferrocyanide is dissolved in 10 mL of water and added 1 drop of this solution. When a few drops of 2 N acetic acid and that is saturated with benzidine and 1 drop of 1% lead nitrate are added, blue precipitates or color should not formed.

(3) Lead : Accurately weigh 5.0 g of calcium ferrocyanide into a 150 mL beaker, add 30 mL of water. Add Hydrochloric acid in small portion to the solution until the solid is dissolved throughly and add 1 mL of hydrochloric acid. Heat this solution for approximately 5 minutes and cool down. Add water to bring the total volume to 100 mL. Add Sodium Hydroxide Solution(1→4) or Hydrochloric acid(1→4) so that pH becomes 2 ~ 4. Transfer this solution into 250 mL separatory funnel, where water is added to make 200 mL. Then add 2 mL of 2% APDC solution and shake to mix. Extract the solution 2 times with 20 mL each of chloroform, which is evaporated to dryness in a water bath. Add 3 mL of Nitric Acid to the residue and heat it until nearly evaporated. To this solution, add 0.5 mL of Nitric Acid and 10 mL of water, concentrate it until the final solution becomes 3~5 mL, and add water to make 10 mL, test solution. When the test solution is tested by Atomic Absorption Spectrophotometry or Inductively Coupled Plasma Emission Spectroscopy, its content should not be more than 5.0 ppm.

2% APDC Solution : 2.0 g of Ammonium Pyrolidine Dithiocarbamate is dissolved in water to make 100 mL. Filter it when using.

(4) Chloride : When 0.11 g of calcium ferrocyanide is tested by Chloride Limit Test, the detected amount should not be more than the amount that corresponds to 0.6 mL of 0.01 N hydrochloric acid.(not

more than 0.2%)

- (1) (5) Sulfate : When 0.2 g of calcium ferrocyanide is tested by Sulfate Limit Test, the detected amount should not be more than the amount that corresponds to 0.4 mL of 0.01 N hydrochloric acid. (not more than 0.1%)

Water Content Water content of calcium ferrocyanide is determined by water determination (Karl-Fisher Titration) and should not be more than 1.0%.

Assay About 1.0 mg of calcium ferrocyanide is weighed accurately, dissolved in 200 mL of water, and 10 mL of sulfuric acid is added. Then the solution is titrated with 0.02 N potassium permanganate until the red color lasts for 30 secs.

0.02 N potassium permanganate 1 mL = 50.83 mg of $\text{Ca}_2\text{Fe}(\text{CN})_6 \cdot 12\text{H}_2\text{O}$

Calcium Gluconate

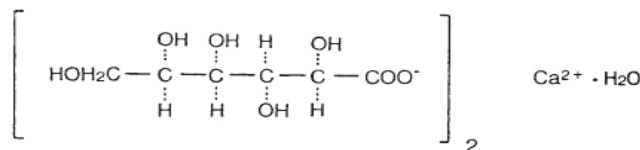

Chemical Formula: $(\text{C}_6\text{H}_{11}\text{O}_7)_2\text{Ca} \cdot \text{H}_2\text{O}$

Molecular Weight: 448.40

INS No.: 578

Synonyms: Calcium salt of D-gluconic acid

CAS No.: 299-28-5

Compositional Specifications of Calcium Gluconate

Content Calcium Gluconate, when calculated on the dried basis, should contain within a range of 98.0~104.0% of calcium gluconate $[(\text{C}_6\text{H}_{11}\text{O}_7)_2\text{Ca} \cdot \text{H}_2\text{O}]$.

Description Calcium Gluconate occurs as a white crystalline or granular powder without odor and taste.

Identification (1) A solution of Calcium Gluconate (1→40) responds to the test for Calcium Salt in Identification.

(2) To 1 mL of Calcium Gluconate solution (1→40), add 1 drop of ferric chloride solution, the solution develops a dark yellow color.

(3) To 5 mL of warm solution of Calcium Gluconate (1→10), add 0.7 mL of glacial acetic acid and 1 mL of freshly distilled phenylhydrazine and heat in a water bath for 30 minutes and cool. When the inner wall is rubbed with a glass rod, crystals are precipitated. These crystals are collected and dissolved in 10 mL of boiling water, where small amount of activated carbon is added. After mixing by shaking, it is filtered. After cooling, the inner wall is rubbed with a glass rod to precipitate crystals. The melting point of the dried crystals should be 196 ~ 202°C (decomposition).

Purity (1) Clarity and Color of Solution : When 1 g of Calcium Gluconate is dissolved in 20 mL of water by heating at 60°C, the solution should not be more than almost clear.

(2) Chloride : When 0.3 g of Calcium Gluconate is tested by Chloride Limit Test, its content should not be more than the amount that corresponds to 0.6 mL of 0.01 N hydrochloric acid.

(3) Sulfate : When 0.5 g of Calcium Gluconate is tested by Sulfate Limit Test, its content should not be more than the amount that corresponds to 0.5 mL of 0.01 N sulfuric acid.

(4) Arsenic : It should be no more than 4.0 ppm tested by Arsenic Limit Test.

(5) Lead : When 5.0 g of Calcium Gluconate is tested by Atomic Absorption Spectrophotometry or Inductively Coupled Plasma Emission Spectroscopy, its content should not be more than 2.0 ppm.

(6) Sucrose or Reducing Sugar : To 0.5 g of Calcium Gluconate, add 10 mL of water and 2 mL of dilute hydrochloric acid, and boil for 2 minutes. After cooling, 5 mL of sodium carbonate solution is added,

which is set-aside for 5 minutes. The solution is diluted to 20 mL with water, which is then filtered. Take 5 mL of the filtrate is mixed with 2 mL of Fehling solution, which is boiled for 1 minute. An orange-yellow ~ red precipitate should not be formed immediately.

Loss on Drying When Calcium Gluconate is dried for 2 hours at 80°C, the weight loss should not be more than 0.5%.

Assay Accurately weigh about 0.5 g of Calcium Gluconate, previously dried, and dissolve in 5 mL of dilute hydrochloric acid, and add 50 mL of water, 25 mL of sodium hydroxide solution, and about 0.1 g 2-oxy-1-(2'-oxy-4'-sulfo-1- naphthylazo)-3-naphthoic acid. Immediately, the solution titrated with 0.05 M EDTA solution. At the end point, the red color completely disappears and the solution turns blue.

1 mL of 0.05 M EDTA solution = 22.42 mg $(C_6H_{11}O_7)_2Ca \cdot H_2O$

Calcium Glycerophosphate

Chemical Formula: $C_3H_7CaO_6P$

INS No.: 383

Molecular Weight: 210.14

CAS No.: 27214-00-2

Compositional Specifications of Calcium Glycerophosphate

Content Calcium Glycerophosphate, when calculated on the dried basis, should contain within a range of 98.0 ~ 100.5% of calcium glycerophosphate ($C_3H_7CaO_6P$).

Description Calcium Glycerophosphate occurs as a white powder. It is odorless and has a slightly bitter taste.

Identification Saturated Calcium Glycerophosphate solution responds to the test for Calcium Salts in Identification.

Purity (1) Alkalinity : To Calcium Glycerophosphate solution (1→60), 3 drops of phenolphthalein are added. It is then neutralized with 0.1 N sulfuric acid. The consumption should not be more than 1.5 mL.

(2) Lead : When 5.0 g of Calcium Glycerophosphate is tested by Atomic Absorption Spectrophotometry or Inductively Coupled Plasma Emission Spectroscopy, its content should not be more than 4.0 ppm.

Loss on Drying When Calcium Glycerophosphate is dried for 4 hours at 150°C, the weight loss should not be more than 12.0%.

Assay 2 g of Calcium Glycerophosphate, previously dried for 4 hours at 150°C and accurately weighed, is dissolved in 100 mL of water and 5 mL of dilute hydrochloric acid, and add water to make 250 mL, thoroughly mix. Precisely weigh 50 mL of this solution, 50 mL of water is added to it. Approximately 30 mL of 0.05M EDTA solution is added while stirring, 15 mL of sodium hydroxide and 0.3 g of hydroxynaphthylblue are added and mixed well. The solution is titrated with 0.05 M EDTA solution. The end point is where the red color completely disappear and it turns blue.

1mL of 0.05M EDTA = 10.51mg $C_3H_7CaO_6P$

Calcium Hydroxide

Chemical Formula: $\text{Ca}(\text{OH})_2$

Molecular Weight: 74.10

INS No.: 526

Synonyms: Slaked lime

CAS No.: 1305-62-0

Compositional Specifications of Calcium Hydroxide

Content Calcium Hydroxide should contain not less than 95.0% of calcium hydroxide ($\text{Ca}(\text{OH})_2$).

Description Calcium Hydroxide occurs as a white powder.

Identification (1) To Calcium Hydroxide, add 3 ~ 4 times the amount of calcium hydroxide with water. The mixture becomes muddy and alkaline.

(2) To 1 g of Calcium Hydroxide, add 20 mL of water and 6 mL of acetic acid and dissolve. The solution responds to test of Calcium Salt in Identification.

Purity (1) Hydrochloric Acid-Insoluble Substances : 2 g of Calcium Hydroxide is dissolved in 10 mL of hydrochloric acid and 20 mL of water, and boil. After cooling, filter through a filter paper for quantitative analysis, wash the residue on the filter paper with boiling water until the washings no longer respond to the test by Chloride Limit Test. Incinerate together with the filter paper and weigh the residue. The amount of residue should not be more than 10 mg.

(2) Carbonate : To 2 g of Calcium Hydroxide, add 50 mL of water, shake well, and add 25 mL of diluted hydrochloric acid. No remarkable bubbles should occur.

(3) Arsenic : It should be no more than 4.0 ppm tested by Arsenic Limit Test.

(4) Lead : Calcium Hydroxide is tested by purity (2) for 「Sodium Metaphosphate」(not more than 2.0 ppm).

(5) Fluoride : 1 g of Calcium Hydroxide is precisely weighed and is tested by purity (8) for 「Calcium Citrate」(not more than 50 ppm).

(6) Alkali Metals and Magnesium : 0.5 g of Calcium Hydroxide is dissolved in 30 mL of 1N hydrochloric acid by heating in a water bath, if necessary. Neutralize with ammonia solution, add 30 mL of ammonium oxalate, and boil for 1 hour in a water bath. After cooling, add water to make total volume to 100 mL, mix well by stirring, and filter. Add 0.5 mL of sulfuric acid to 50 mL of the filtrate, evaporate to dryness, and heat treat until weight becomes constant. The amount of residue should not be more than 12 mg.

(7) Barium : 1.5 g of Calcium Hydroxide dissolve in 15 mL of dilute hydrochloric acid, add water to make 30 mL, and filter. Take 20 mL of the filtrate, and add 2 g of sodium acetate, 1 mL of diluted acetic acid, and 0.5 mL of potassium chromate solution. After setting it aside for 15 minute, its turbidity should not be more than the that of the solution which is made in the same manner, to 0.3 mL of Barium

standard solution, water is added to make 20 mL(not more than 0.03%).

Assay Approximately 2 g of Calcium Hydroxide is precisely weighed and dissolved in 30 mL of dilute hydrochloric acid, which is diluted to 250 mL with water. To 10 mL of this solution, add 15 mL of sodium hydroxide solution (1→10), 3 mL of potassium cyanide solution (1→20), and 100 mL of water, which is set-aside for approximately 1 minute. Add 0.1 g of 2-oxy-1-(2'-oxy-4'-sulfo-1-naphtyl azo)-3-naphthoic acid, which is immediately titrated with 0.05 M EDTA solution. At the end point, the red color completely disappears and the solution turns blue.

1 mL of 0.05 M EDTA solution = 3.705 mg Ca(OH)_2

Calcium Hypochlorite

Synonyms: Highest bleaching powder

CAS No.: 7778-54-3

Compositional Specifications of Calcium Hypochlorite

Content Calcium Hypochlorite should contain not less than 60.0% effective chlorine.

Description Calcium Hypochlorite is white ~ milky white granule or powder with a characteristic odor of chlorine.

Identification (1) 0.5 g of Bleaching Powder is mixed with 5 mL of water by shaking. When a red litmus paper is dipped into this solution, it turns blue and then decolorizes.

(2) When 2 mL of acetic acid is added to 0.1 g of Bleaching Powder, gas is evolved and it dissolves. 5 mL of water is added. It is then filtered. The filtrate responds to the test for Calcium Slat of Identification.

Assay Accurately weighed 4 g of Calcium Hypochlorite is finely ground with approximately 50 mL of water in a mortar. The mixture transfer into a 1000 mL volumetric flask and water is added so that the total volume is brought up to 1000 mL. To 50 mL of this solution, 2 g of potassium iodide and 10 mL of glacial acetic acid (1→2) are added. Free iodine is titrated with 0.1 N sodium thiosulfate solution (indicator : starch solution). Separately, a blank test is carried out in the same manner.

1 mL of 0.1 N sodium thiosulfate solution = 3.546 mg Cl

Calcium Lactate

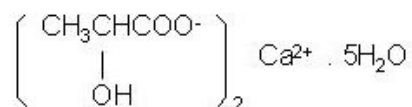

Chemical Formula: $\text{C}_6\text{H}_{10}\text{O}_6\text{Ca} \cdot 5\text{H}_2\text{O}$

Molecular Weight: 308.31

INS No.: 327

Synonyms: Calcium dilactate; Calcium dilactate hydrate

CAS No.: 5743-48-6

Compositional Specifications of Calcium Lactate

Content Calcium Lactate, when calculated on the dried basis, should contain within a range of 98.0 ~ 101.0% of calcium lactate ($\text{C}_6\text{H}_{10}\text{O}_6\text{Ca} = 218.23$).

Description Calcium Lactate occurs as white powder or granules. It is odorless or has a slight, characteristic odor.

Identification Calcium Lactate solution (1→20) responds to the tests for Calcium Salt and Lactate.

Purity (1) Clarity and Color of Solution : Weigh 1 g of Calcium Lactate, add 20 mL of water, and dissolve while heating in a water bath. This solution is colorless and clear.

(2) pH : Weigh 1 g of Calcium Lactate, add 20 mL of water, dissolve while heating in a water bath, and cool. pH of this solution should be within a range of 6.0 ~ 8.0

(3) Arsenic : It should be no more than 4.0 ppm tested by Arsenic Limit Test.

(4) Lead : When 5.0 g of Calcium Lactate is tested by Atomic Absorption Spectrophotometry or Inductively Coupled Plasma Emission Spectroscopy, its content should not be more than 2.0 ppm.

(5) Mercury : When Calcium Lactate is tested by Mercury Limit Test, its content should not be more than 1.0 ppm.

(6) Fluoride : 1 g of Calcium Lactate is precisely weighed and is tested by purity (8) for 「Calcium Citrate」, its content should not be more than 30 ppm.

(7) Alkali Metals and Magnesium : 1.0 g of Calcium Lactate dissolve in about 40 mL of water, add 0.5 g of ammonium chloride, and boil. Add about 20 mL of ammonium oxalate solution, heat in a water bath for 1 hour, cool, add water to make 100 mL, and filter. Measure 50 mL of the filtrate, add 0.5 mL of sulfuric acid, evaporate to dryness, ignite to constant weigh, and weigh the residue. The amount of residue should not be more than 5 mg.

(8) Volatile Fatty Acid : To 0.5 g of Calcium Lactate, 1 mL of sulfuric acid is added. When it is heated in a water bath, an odor of fatty acid should not be generated.

Loss on Drying When Calcium Lactate is dried for 4 hours at 120°C, the loss should not be more than 30%.

Assay Dissolve 1g of Calcium Lactate, precisely dried and accurately weighed, in 20 mL of dilute hydrochloric acid, where water is added to make 100 mL solution. Take 10 mL of this solution and test by Assay for [Calcium Hydroxide]

1 mL of 0.05 M EDTA = 10.91 mg of $C_6H_{10}O_6Ca$

Calcium Oxide

Chemical Formula: CaO

Molecular Weight: 56.08

Synonyms: Lime

INS No.: 529

CAS No.: 1305-78-8

Compositional Specifications of Calcium Oxide

Content After being heat-treated, Calcium Oxide is quantitatively analyzed. It should contain 95.0~100.5% of calcium oxide (CaO).

Description Calcium Oxide is white ~ grayish white hard lump, granule, or powder.

Identification 20 mL of water is added to 1 g of Calcium Oxide. Acetic acid is added until it dissolves. The resulting solution responds to the test for calcium salts in Identification.

Purity (1) Acid Insoluble substances : 100 mL of water is added to 5 g of Calcium Oxide. It is dissolved by adding (drop wise) sufficient amount of hydrochloric acid. The solution is heated and then cooled. If necessary, hydrochloric acid is added until the solution becomes distinctly acidic. It is then filtered through a porcelain filter that is previously weighed. The residue is washed with water until the wash water doesn't show the reaction of chlorides. After drying for 1 hour at 105°C, the content should not be more than 1.0%.

(2) Alkali or Magnesium : 0.5 g of Calcium Oxide is dissolved in 30 mL of water and 15 mL of dilute hydrochloric acid, which is boiled for 1 minute. 40 mL of oxalic acid solution is immediately added to the solution, which is shaken vigorously. 2 drops of methyl red solution are added. The resulting solution is neutralized with ammonia solution until calcium is completely precipitated. It is then heated for 1 hour in a water bath. After cooling, the total volume is brought up to 10 mL with water, which is then filtered. 0.5 mL of sulfuric acid is added to 50 mL of the filtrate, which is evaporated to dryness. The residue is heat-treated in a platinum crucible at $800 \pm 25^\circ\text{C}$ until the weight becomes constant. The content should not be more than 3.6%.

(3) Fluoride : 1 g of Calcium Oxide is precisely weighed and is tested by Purity (8) for 「Calcium Citrate」 (not more than 50 ppm).

(4) Arsenic : It should be no more than 4.0 ppm tested by Arsenic Limit Test.

(5) Barium : Mix 1.5g of Calcium Oxide with 10mL of water, add 15 mL of dilute hydrochloric acid solution, add water to make 30mL and filter. The filtrate is used as Test Solution. Separately, take 0.3 mL of barium standard solution, and add water to make 20 mL, Reference Solution. To 20 mL of test solution and reference solution, add 2g of sodium acetate, 1 mL of dilute acetic acid and 0.5 mL of potassium chromate solution, and allow to stand for 15 minute. The turbidity of test solution should not be more than that of reference solution (not more than 0.03%).

(6) Lead : Calcium Oxide is tested by purity (2) for 「Sodium Metaphosphate」(not more than 2.0 ppm).

Loss on Ignition Precisely weighed 1 g of Calcium Oxide is heat-treated at $1,100 \pm 50^\circ\text{C}$ until the weight becomes constant. The weight loss should not be more than 10.0%.

Assay 1 g of Calcium Oxide is heated until the weight becomes constant, which is then precisely weighed and dissolved in 20 mL of dilute hydrochloric acid. After cooling, the solution is diluted to 500 mL with water. 50 mL of water is added to 50 mL of the resulting solution, then, add 15 mL of sodium hydroxide test solution while stirring. 15 mL of sodium hydroxide solution and 0.3 g of hydroxy naphthol blue hydroxynaphtholblue ($\text{C}_{20}\text{H}_{12}\text{O}_{11}\text{S}_3\text{Na}_2$) are added to the resulting solution, which is then titrated with 0.05 M EDTA solution. The end point is where the red color of the solution disappears completely and the solution turns blue.

1 mL of 0.05 M EDTA = 2.804 mg CaO

Calcium Pantothenate

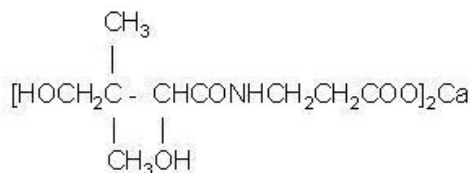

Chemical Formula $\text{C}_{18}\text{H}_{32}\text{O}_{10}\text{N}_2\text{Ca}$

Molecular Weight 476.55

Compositional Specifications of Calcium Pantothenate

Content Calcium Pantothenate, when calculated on the dried basis, should contain within a range of 5.7 ~ 6.0% of nitrogen (N = 14.01) and 8.2 ~ 8.6% of calcium (Ca = 40.08).

Description Calcium Pantothenate occurs as a white powder. It is odorless and has a slightly bitter taste.

Identification (1) To 50 mg of Calcium Pantothenate, add 5 mL of sodium hydroxide solution and 1 drop of cupric sulfate solution, the solution becomes blue-purple color.

(2) To 50 mg of Calcium Pantothenate, add 5 mL of sodium hydroxide solution, and boil for 1 minute. Cool, and add 2 mL of diluted hydrochloric acid and 2 drops of ferric chloride Solution, the solution becomes a dark yellow color.

(3) Calcium Pantothenate solution (1→20) responds to test of Calcium Salt in Identification.

Purity (1) pH : pH of Calcium Pantothenate solution (2→10) should be within a range of 7.0 ~ 9.0.

(2) Specific rotation : Approximately 1.25 g of Calcium Pantothenate, previously dried for 3 hours at 105°C and precisely weighed, is dissolved in 25 mL of water. Optical rotation of Calcium Pantothenate should be within a range of $[\alpha]_D^{20} = +25 \sim +28.5^\circ$.

(3) Arsenic : It should be no more than 4.0 ppm tested by Arsenic Limit Test.

(4) Lead : When 5.0 g of Calcium Pantothenate is tested by Atomic Absorption Spectrophotometry or Inductively Coupled Plasma Emission Spectroscopy, its content should not be more than 2.0 ppm.

(5) Alkaloid : When weigh 50 mg of Calcium Pantothenate, dissolve in 5 mL of water, and add 0.5 mL of ammonium molybdate solution and 0.5 mL of diluted phosphoric acid (1→10), the solution should not be turbid.

Loss on Drying When Calcium Pantothenate is dried for 3 hours at 105°C, the weight loss should not be more than 5%.

Assay (1) Nitrogen : Accurately weigh about 50 mg of Calcium Pantothenate, proceed as directed under Semi-micro Kjeldahl Method under Nitrogen Determination, and calculate on the dried basis.

(2) Calcium : Approximately 0.5 g of Calcium Pantothenate, previously dried and precisely weighed, is dissolved in 80 mL of water, add 15 mL of 0.05 M EDTA solution, 15 mL of sodium hydroxide solution (1→10) and approximately 0.1 g of 2-oxy-1-(2'-oxy-4'-sulfo-1'-naphthylazo)-3-naphthoic acid. It is then titrated with 0.05 M EDTA solution. End point is where the red color of the solution completely

disappears and becomes to blue.

1 mL of 0.05 M EDTA solution = 2.004 mg Ca

Calcium Phosphate, Dibasic

Chemical Formula: $\text{CaHPO}_4 \cdot 0 \sim 2\text{H}_2\text{O}$

Molecular Weight: 136.06(anhydrous)

INS No.: 341(ii)

Synonyms: Calcium hydrogen phosphate;
Dicalcium phosphate

CAS No.:
7757-93-9(anhydrous)
7789-77-7(2 hydrates)

Compositional Specifications of Calcium Phosphate, Dibasic

Content Calcium Phosphate, Dibasic, when calculated on the dried basis, should contain within a range of 98.0 ~ 103.0% dibasic calcium phosphate ($\text{CaHPO}_4 = 136.06$)

Description Calcium Phosphate, Dibasic is odorless and tasteless white crystalline powder or powder.

Identification (1) Calcium Phosphate, Dibasic turns yellow by wetting with silver nitrate solution.

(2) 5 mL of acetic acid is added to 0.1 g of Calcium Phosphate, Dibasic, which is then boiled, cooled, and filtered. The filtrate adding 5 mL of ammonium hydroxide solution, white precipitates are formed.

Purity (1) Arsenic : It should be no more than 4.0 ppm tested by Arsenic Limit Test.

(2) Lead : Calcium Phosphate, Dibasic is precisely weighed and is tested by purity (2) for 「Sodium Metaphosphate」, its content should not be more than 4.0 ppm.

(3) Cadmium : Calcium Phosphate, Dibasic is precisely weighed and is tested by purity (3) for 「Sodium Metaphosphate」, its content should not be more than 1.0 ppm.

(4) Mercury : When Calcium Phosphate, Dibasic is tested by Mercury Limit Test, its content should not be more than 1.0 ppm.

(5) Fluoride : 1 g of Calcium Phosphate, Dibasic is precisely weighed and is tested by purity (8) for 「Calcium Citrate」, its content should not be more than 10 ppm.

Loss on Drying When Calcium Phosphate, Dibasic is dried for 3 hours at 200°C, the loss should not be more than 22%.

Assay Dissolve 0.3 g of Calcium Phosphate, Dibasic, precisely dried and accurately weighed, in 10 mL of dilute hydrochloric acid. Water is added to bring the total volume to 120 mL. It is then quantitatively analyzed following the Assay for 「Calcium Phosphate, Monobasic」.

1 mL of 0.1 N potassium permanganate = 6.803 mg of CaHPO_4

Calcium Phosphate, Monobasic

Chemical Formula: $\text{Ca}(\text{H}_2\text{PO}_4)_2 \cdot n\text{H}_2\text{O}$ (n= 1 or 0)

Molecular Weight: 234.05(anhydrous)

INS No.: 341(i)

Synonyms: Calcium dihydrogen phosphate; Acid
calcium phosphate

CAS No.:

7758-23-8(anhydrous)

10031-30-8(hydrate)

Compositional Specifications of Calcium Phosphate, Monobasic]

Content Anhydrous and hydrate of Calcium Phosphate, Monobasic should contain 16.8% ~ 18.3% and 15.9~17.7% as calcium, after drying or heat-treating.

Description Calcium Phosphate, Monobasic is hygroscopic white crystal, granule, or powder.

Identification (1) Calcium Phosphate, Monobasic turns yellow by wetting with silver nitrate solution.

(2) To 0.1 g of Calcium Phosphate, Monobasic, add 20 mL of water and shake, and filter. Add 5 mL of ammonium hydroxide solution, white precipitates are formed.

Purity (1) Arsenic : It should be no more than 4.0 ppm tested by Arsenic Limit Test.

(2) Lead : Calcium Phosphate, Monobasic is precisely weighed and is tested by purity (2) for 「Sodium Metaphosphate」, its content should not be more than 4.0 ppm.

(3) Cadmium : Calcium Phosphate, Monobasic is precisely weighed and is tested by purity (3) for 「Sodium Metaphosphate」, its content should not be more than 1.0 ppm.

(4) Mercury : When Calcium Phosphate, Monobasic is tested by Mercury Limit Test, its content should not be more than 1.0 ppm.

(5) Fluoride : 1 g of Calcium Phosphate, Monobasic is precisely weighed and is tested by purity (8) for 「Calcium Citrate」, its content should not be more than 10 ppm.

Loss on Drying When hydrated form of Calcium Phosphate, Monobasic is dried for 3 hours at 60°C, the loss should not be more than 1%.

Loss on Ignition When thermogravimetric analysis is done with anhydrous form of Calcium Phosphate, Monobasic at 800°C for 30 minutes, weight loss should not be more than 14.0 ~ 15.5%.

Assay Dissolve 475 mg of Calcium Phosphate, Monobasic, precisely dried or heat-treated and accurately weighed, in 10 mL of hydrochloric acid. After adding a few drops of methyl orange, the solution is boiled for 5 minutes and hydrochloric acid or water is added to adjust pH while boiling. 2 drops of methylred and 30 mL of ammonium hydroxide solution are added and mixed. 6 N ammonia solution and water are added until the pink color disappears. The resulting liquid is heated in a water bath and cooled in air until the precipitates are settled down. The supernatant is filtered through a glass filter, which is repeated 3 times. Rinse water is filtered and the beaker is rinsed with 10 mL of cold water

(20°C or below) twice, which is also filtered. 100 mL of water and 50 mL of cold dilute sulfuric acid (1→6) are added to the filtrate, which is then titrated with 0.1 N potassium permanganate.

1 mL of 0.1 N potassium permanganate = 2.004 mg Ca

Calcium Phosphate, Tribasic

Chemical Formula: $\text{Ca}_3(\text{PO}_4)_2$, $\text{Ca}_5\text{OH}(\text{PO}_4)_3$

Molecular Weight: 310.18, 502.31

INS No.: 341(iii)

Synonyms: Calcium hydroxyapatite; Tricalcium phosphate; Calcium orthophosphate

CAS No.: 7758-87-4

Compositional Specifications of Calcium Phosphate, Tribasic

Content Calcium Phosphate, Tribasic, when calculated on the dried basis, should contain not less than 90.0% of tribasic calcium phosphate [$\text{Ca}_3(\text{PO}_4)_2$].

Description Calcium Phosphate, Tribasic is odorless and tasteless white powder.

Identification (1) Calcium Phosphate, Tribasic turns yellow by wetting with silver nitrate solution.

(2) To 0.1 g of Calcium Phosphate, Tribasic, add 5 mL of acetic acid, and boil, cool, and filter. To filtrate, add 5 mL of ammonium hydroxide solution, white precipitates are formed.

Purity (1) Arsenic : It should be no more than 4.0 ppm tested by Arsenic Limit Test.

(2) Lead : Calcium Phosphate, Tribasic is precisely weighed and is tested by purity (2) for 「Sodium Metaphosphate」, its content should not be more than 4.0 ppm.

(3) Cadmium : Calcium Phosphate, Tribasic is precisely weighed and is tested by purity (3) for 「Sodium Metaphosphate」, its content should not be more than 1.0 ppm.

(4) Mercury : When Calcium Phosphate, Tribasic is tested by Mercury Limit Test, its content should not be more than 1.0 ppm.

(5) Fluoride : 1 g of Calcium Phosphate, Tribasic is precisely weighed and is tested by purity (8) for 「Calcium Citrate」, its content should not be more than 50 ppm.

Loss on Drying

When Calcium Phosphate, Tribasic is dried for 3 hours at 200°C, the loss should not be more than 10%.

Assay

200 mg of Calcium Phosphate, Tribasic, precisely weighed, dissolve in 25 mL water and 10 mL dilute hydrochloric acid. It is filtered, if necessary, and the residue is dissolved by adding 1 mL of dilute hydrochloric acid. The solution is kept at 50°C, where 75 mL of ammonium molybdate solution is added and stirred occasionally for 30 minutes. Precipitates are washed with 30 ~ 40 mL of water 1 ~ 2 times. Precipitates are transferred on to a filter paper and washed with potassium nitrate solution (1→1000) until the final rinse solution does not show acidity as determined with a litmus paper. Precipitates and filter paper is transferred into a container. 40 mL of 1 N sodium hydroxide solution is added and stirred until the precipitates are dissolved. Excess alkali is titrated with 1 N sulfuric acid.

1 mL of 1 N sodium hydroxide solution = 6.743 mg $\text{Ca}_3(\text{PO}_4)_2$

Calcium Propionate

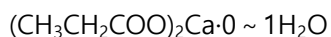

Chemical Formula: $\text{C}_6\text{H}_{10}\text{O}_4\text{Ca}\cdot n\text{H}_2\text{O}$ ($n = 1$ or 0)

Molecular Weight: 204.23(1 hydrate)

186.22(anhydrous)

INS No.: 282

Synonyms: Calcium propionate

CAS No.: 4075-81-4

Compositional Specifications of Calcium Propionate

Content Calcium Propionate, when calculated on the dried basis, should contain not less than 98.0% of calcium propionate ($\text{C}_6\text{H}_{10}\text{O}_4\text{Ca} = 186.22$).

Description Calcium Propionate occurs as white crystals, powder or granules. It is odorless or has a slight, characteristic odor.

Identification (1) 0.5 g of Calcium Propionate is dissolved in 5 mL of water. When 5 mL of dilute sulfuric acid is added to a this solution, heat, a characteristic odor is generated.

(2) Calcium Propionate responds to the test for Calcium Salt.

Purity (1) Water-Insoluble Substances : To 10 g of Calcium Propionate, add 100 mL of water, and allow to stand for 1 hour while shaking occasionally. Filter the insoluble substances through a glass filter (IG4), wash with 30 mL of water, and dry at 180°C for 4 hours, and weigh the residue. Its content should not be more than 20mg.

(2) Free Acid and Free Alkali : Weigh 2 g of Calcium Propionate, dissolve in 20 mL of freshly boiled and cooled water, and add 2 drops of phenolphthalein solution, test solution. Proceed as directed under Purity (2) in 「Sodium Propionate」.

(3) Arsenic : It should be no more than 4.0 ppm tested by Arsenic Limit Test.

(4) Lead : When 5.0 g of Calcium Propionate is tested by Atomic Absorption Spectrophotometry or Inductively Coupled Plasma Emission Spectroscopy, its content should not be more than 5.0 ppm.

(5) Iron : When 5.0 g of Calcium Propionate is tested by Atomic Absorption Spectrophotometry or Inductively Coupled Plasma Emission Spectroscopy, its content should not be more than 50 ppm.

(6) Mercury : When Calcium Propionate is tested by Mercury Limit Test, its content should not be more than 1.0 ppm.

(7) Fluorides : 1 g of Calcium Propionate is accurately weighed and proceeded as directed under Purity (8) for 「Calcium Citrate」(not more than 10 ppm).

Loss on Drying When Calcium Propionate is dried for 2 hours at 120°C , the weight loss should not be more than 9.5%.

Assay Accurately weigh about 1 g of Calcium Propionate, previously dried, and dissolve in water to make exactly 100 mL. Take 25 mL of this solution, add 75 mL of water and 15 mL of 0.1% sodium hydroxide

solution, and allow to stand for about 1 minute. 0.1 g of 2-oxy-1-(2'-oxy-4'-sulfo-1-naphtylazo)-2-naphthoic acid is added to the resulting solution, which is immediately titrated with 0.05 M EDTA solution. At the end point, the red color completely disappears and the solution turns blue.

1 mL of 0.05 M EDTA = 9.312 mg of $C_6H_{10}O_4Ca$

Calcium 5'-Ribonucleotide

Synonyms: Calcium ribonucleotides

INS No.: 634

Definition Calcium 5'-Ribonucleotide is a mixture of calcium 5'-inosinate, calcium 5'- guanylate, calcium 5'-cytidylate, and calcium 5'-uridylate.

Compositional Specifications of Calcium 5'-Ribonucleotide

Content If Calcium 5'-Ribonucleotide, when calculated on the anhydrous dried basis, it should contain within a range of 97.0~102.0% of 5'-calcium ribonucleotide, 95% of which is made of calcium 5'-inosinate and calcium 5'-guanylate.

Description Calcium 5'-Ribonucleotide occurs white to milky white crystal or powder. It is odorless and has a slight characteristic taste.

Identification (1) 0.1 g of Calcium 5'-Ribonucleotide is dissolved in 200 mL water by heating in a water bath. After cooling, 1 mL of this solution taken 0.2 mL of orcinol in ethanol (1→10) is added, which is tested by the Identification (1) of 「Disodium 5'-Ribonucleotide」.

(2) To 0.1 g of Calcium 5'-Ribonucleotide, add 5 mL of water and 5 mL of nitric acid, and gently boil and cool. It is then titrated with aqueous ammonia or ammonia solution. Add water to make 100 mL, this solution shows reaction of phosphate (B) of Identification.

(3) To 2 mL of Calcium 5'-Ribonucleotide in diluted hydrochloric acid (1→2,000), add 0.1 g of zinc powder, and test by Identification (3) 「Disodium 5'-Ribonucleotide」.

(4) 0.1 g of Calcium 5'-Ribonucleotide is dissolved in 500 mL of water by heating in a water bath. After cooling, take 1 mL of the solution, add 1 mL of dilute hydrochloric acid. The solution is tested by Identification (4) 「Disodium 5'-Ribonucleotide」.

(5) To 0.5 g of Calcium 5'-Ribonucleotide, add 10 mL of 0.5 N sulfuric acid, thoroughly stir-mixed and settled for 5 minutes, which is neutralized with sodium hydroxide solution and then filtrated. The filtrate is evaporated to dryness. The residue is dissolved in 10 mL of this solution, that sodium hydroxide solution is added to 50 mL of hydroxylamine hydrochloride solution (7→50), so that pH becomes approximately 6.5, and test by Identification (5) of 「Disodium 5'-ribonucleotide」.

(6) 0.1 g of Calcium 5'-Ribonucleotide is dissolved in 20 mL of water by heating in a water bath and cooled. The solution responds to the test for Calcium Salts in Identification.

Purity

(1) Water Solubles : 1 g of Calcium 5'-Ribonucleotide is dissolved in 50 mL of water by stir-mixing for 10 minutes, which is then filtered through a filter paper for quantitative analysis. Take 25 mL of filtrate, evaporate to dryness and the residue is further dried at 105°C for 1 hour. The amount of water solubles should not be more than 80 mg.

(2) pH : 0.1 g of Calcium 5'-Ribonucleotide is dissolved in 200 mL of water by heating in a water bath. After cooling, pH of the solution should be within in a range of 7.0 ~ 8.0.

(3) Arsenic : It should be no more than 4.0 ppm tested by Arsenic Limit Test.

(4) Lead : When 5.0 g of Calcium 5'-Ribonucleotide is tested by Atomic Absorption Spectrophotometry or Inductively Coupled Plasma Emission Spectroscopy, its content should not be more than 1.0 ppm.

Water Content

Proceed as directed under Water Content in 「Disodium 5'-Ribonucleotide」, it should not be more than 23%.

Assay

Using the values of Ica, Gca, and Pca from (1), (2), and (3), contents of calcium 5'-ribonucleotide, (C₁₀H₁₁CaN₄O₈P), and calcium 5'-guanylate (C₁₀H₁₂CaN₅O₈P) are calculated using the following equations.

$$\text{Content of calcium 5'-ribonucleotide(\%)} = \frac{\text{Ica} + \text{Gca} + \text{Pca}}{100 - \text{water content(\%)}} \times 100$$

$$\begin{aligned} \text{Content of calcium 5'-inosinate} \\ \text{and calcium 5'- guanylate(\%)} &= \frac{\text{Ica} + \text{Gca}}{100 - \text{water content(\%)}} \times 100 \end{aligned}$$

(1) Calcium 5'-Inosinate : 650 mg of Calcium 5'-Ribonucleotide is precisely weighed and dissolved in 0.1 N hydrochloric acid to make 500 mL. This solution is referred to as A solution. A solution is tested by Assay (1) of [Disodium 5'-ribonucleotide]. The resulting value is I (%). The content of calcium 5'-inosinate, Ica (%), is obtained by multiplying I (%) with 0.985.

(2) Calcium 5'-Guanylate : 1 mL of A solution is tested by Assay (2) of [Disodium 5'-guanylate]. The resulting value is G (%). The content of calcium 5'-guanylate, Gca (%), is obtained by multiplying G (%) with 0.986.

(3) Calcium 5'-Cytidylate and Calcium 5'-Uridylate : Approximately 1.5 g of Calcium 5'-Ribonucleotide is precisely weighed and dissolved in 10 mL of 1 N hydrochloric acid, where 1 mL of sodium phosphate(monobasic) standard solution is added. This solution is neutralized with 1 N sodium hydroxide solution and then filtered. Filter paper is rinsed with 10 mL water. This is added to filtrate, where warm water is added so that the total volume is brought up to 50 mL (This solution is referred to as C). C solution is tested by (3) disodium 5'-cytidylate and disodium 5'-uridylate of Assay for [Disodium 5'-Ribonucleotide]. The resulting value is P(%). The content of calcium 5'-cytidylate (C₉H₁₂CaN₃O₈P) and calcium 5'-uridylate (C₉H₁₁CaN₂O₉P), Pca(%) is obtained by multiplying P (%) with 0.984

Calcium silicate

INS No.: 552

Synonyms: Silicic acid calcium salt

CAS No.: 1344-95-2

Definition Calcium silicate is hydrated or dehydrated silicate which consists of CaO and SiO₂.

Compositional Specifications of Calcium Silicate

Content Calcium silicate, when calculated on the dried basis, should contain within a range of 50.0 ~ 95.0% silicon dioxide (SiO₂) and 3.0 ~ 35.0% calcium oxide (CaO).

Description Calcium silicate is strongly hygroscopic white ~ graysh white powder.

Identification (1) 500 mg of Calcium silicate is dissolved in 10 mL of 2.7 N hydrochloric acid, which is then filtered. The filtrate is neutralized with 6 N ammonium hydroxide solution as determined with a litmus paper. The resulting solution responds to test of calcium salt in Identification.

(2) Proceed as directed under Identification (2) for 「Magnesium Silicate」.

Purity (1) Fluoride : 1 g of Calcium silicate is precisely weighed into a beaker and dissolved by adding 10 mL of 1 N hydrochloric acid. It is then boiled for 1 minute. The solution is transferred into a PE beaker and quickly cooled. 15 mL of sodium citrate solution(1→4) and 10 mL of EDTA solution(1→40) are added, shaken, and mixed. pH of the solution is adjusted to 5.4 ~ 5.6 by adding hydrochloric acid(1→10) or sodium hydroxide solution(2→5). The total volume of the solution is brought up to 100 mL by adding water (Test Solution). 50 mL of the Test Solution is transferred into a PE beaker. Electric potential is measured using fluorine electrode . Fluoride concentration (µg/100mL) is measured from a standard curve and it should not be more than 50 ppm.

Standard Solution : 2.210 g of sodium fluoride, which is previously dried for 4 hours at 200°C, is accurately weighed into a PE beaker and dissolved in 200 mL of water. Then add water to bring the total volume to 1,000mL and preserve it in a PE beaker. Measure exactly 5 mL of this solution into a measuring flask, and add water to bring the total volume to 1,000 mL. (1 mL of this solution contains 5µg of fluorine.)

Calibration Curve Preparation : Separately, 1, 2, 3, 5, 10, and 15 mL of standard solution is weighed into a PE beaker, and 15 mL of Trisodium Citrate Solution (1→4) and 10 mL of Disodium Ethylenediaminetetraacetate solution (1→40) are added and mixed. To this solution, Hydrochloric acid (1→10) or Sodium Hydroxide Solution (2→5) are added to bring the pH 5.4~5.6, where water is added to bring the total volume to 100mL, separately. Each of 50 mL of the solution transfer into a PE beaker. Then measure electric potential by using fluorine electrode and prepare calibration curve with the log of fluorine concentration.

(2) Arsenic : It should be no more than 4.0 ppm tested by Arsenic Limit Test.

(3) Lead : Accurately weigh 5.0 g of Sodium Silicoaluminate into a 150 mL beaker, add 30 mL of water. Add Hydrochloric acid in small portion to the solution until the solid is dissolved throughly and add

1 mL of hydrochloric acid. Heat this solution for approximately 5 minutes and cool down. Add water to bring the total volume to 100 mL. Add Sodium Hydroxide Solution(1→4) or Hydrochloric acid(1→4) so that pH becomes 2 ~ 4. Transfer this solution into 250 mL separatory funnel, where water is added to make 200 mL. Then add 2 mL of 2% APDC solution and shake to mix. Extract the solution 2 times with 20 mL each of chloroform, which is evaporated to dryness in a water bath. Add 3 mL of Nitric Acid to the residue and heat it until nearly evaporated. To this solution, add 0.5 mL of Nitric Acid and 10 mL of water, concentrate it until the final solution becomes 3~5 mL, and add water to make 10 mL, test solution. When the test solution is tested by Atomic Absorption Spectrophotometry or Inductively Coupled Plasma Emission Spectroscopy, its content should not be more than 2.0 ppm.

2% APDC Solution : 2.0 g of Ammonium Pyrolidine Dithiocarbamate is dissolved in water to make 100 mL. Filter it when using.

Loss on Drying When Calcium silicate is dried for 2 hours at 105°C, the loss should not be more than 10%.

Loss on Ignition When Calcium silicate is first dried at 105°C for 2 hours and precisely weighed 1 g is further heat treated at 900°C, weight loss should not be more than 5 ~ 14%.

Assay (1) Silicon Dioxide : Approximately 400 mg of Calcium silicate is precisely weighed into a beaker, where 5 mL of water and 10 mL of perchloric acid are added. The mixture is heated until perchloric acid evaporates and white smoke appears. The beaker is covered with a watch glass and heated for additional 15 minutes. 30 mL of water is added to the above mixture, which is then cooled. The residue is slowly washed three times with hot water. The filter paper with residue transfer into a platinum crucible and carbonized. Then it is further heat treated and cooled. Appropriate amount of sulfuric acid is added to the crucible, which is then heat treated at 1,300°C. It is then weighed after cooling. The residue is wetted with 5 drops of sulfuric acid, where 15 mL of hydrofluoric acid is added. The crucible is then slowly heated to remove acids completely and heat treated at 1,000°C or higher until the weight becomes constant. It is then cooled in a desiccator and weighed. The weight loss is the amount of silicon dioxide.

(2) Calcium Oxide : The filtrate in Assay (1) is neutralized with 1 N sodium hydroxide solution, where 30 mL of 0.05 M EDTA solution is added. 15 mL of 1 N sodium hydroxide solution and 0.3 g of hydroxy naphthol blue solution are added to this solution, which is titrated with 0.05 M sodium EDTA solution. At the end point, the solution turns blue.

1 mL of 0.05 M sodium EDTA solution = 2.804 mg CaO

• hydroxy naphthol blue solution : 0.3 g is dissolved in 100 mL of water, where 10 mL of 1 N sodium hydroxide solution, 1 mL of calcium chloride solution (1→200), and water is added to bring the total volume to 165 mL. Finally 1 mL of 0.05 M sodium EDTA solution is added.

Calcium Sorbate

Chemical Formula: $C_{12}H_{14}CaO_4$

INS No.: 203

Molecular Weight: 262.32

CAS No.: 7492-55-9

Compositional Specifications of Calcium Sorbate

Content Calcium Sorbate, when calculated on the dried basis, should contain within a range of 98.0 ~ 102.0% calcium sorbate ($C_{12}H_{14}CaO_4$).

Description Calcium Sorbate is white fine crystalline powder.

Identification (1) 1 g of Calcium Sorbate is heat treated at 800°C. After cooling, it is mixed well in 10 mL of water and dissolved by adding anhydrous acetic acid, which is then filtered. The filtrate responds to test of calcium salt in Identification.

(2) 0.2 g of Calcium Sorbate is dissolved in 5 mL of methanol, where 0.1 mL of 1 N sodium hydroxide solution is added. The mixture is then dissolved in 95 mL of water. When a few drops of bromine solution are added and shaken, the color of solution disappears immediately.

Purity (1) Fluoride : 1 g of Calcium Sorbate is precisely weighed into a beaker and dissolved by adding 10 mL of 1 N hydrochloric acid. It is then boiled for 1 minute. The solution is transferred into a PE beaker and quickly cooled. 15 mL of sodium citrate solution(1→4) and 10 mL of EDTA solution(1→40) are added, shaken, and mixed. pH of the solution is adjusted to 5.4 ~ 5.6 by adding hydrochloric acid(1→10) or sodium hydroxide solution(2→5). The total volume of the solution is brought up to 100 mL by adding water (Test Solution). 50 mL of the Test Solution is transferred into a PE beaker. Electric potential is measured using fluorine electrode . Fluoride concentration ($\mu\text{g}/100\text{mL}$) is measured from a standard curve and it should not be more than 10 ppm.

Standard Solution : 2.210 g of Fluorine Natrium → sodium fluoride, which is previously dried for 4 hours at 200°C, is accurately weighed into a PE beaker and dissolved in 200 mL of water. Then add water to bring the total volume to 1,000mL and preserve it in a PE beaker. Measure exactly 5 mL of this solution into a measuring flask, and add water to bring the total volume to 1,000 mL. (1 mL of this solution contains 5 μg of fluorine.)

Calibration Curve Preparation : Separately, 1, 2, 3, 5, 10, and 15 mL of standard solution is weighed into a PE beaker, and 15 mL of Trisodium Citrate Solution (1→4) and 10 mL of Disodium Ethylenediaminetetraacetate solution (1→40) are added and mixed. To this solution, Hydrochloric acid (1→10) or Sodium Hydroxide Solution (2→5) are added to bring the pH 5.4~5.6, where water is added to bring the total volume to 100mL, separately. Each of 50 mL of the solution transfer into a PE beaker. Then measure electric potential by using fluorine electrode and prepare calibration curve with the log of fluorine concentration.

- (2) Lead : When 5.0 g of Calcium Sorbate is tested by Atomic Absorption Spectrophotometry or Inductively Coupled Plasma Emission Spectroscopy, its content should not be more than 2.0 ppm.
- (3) Mercury : When Calcium Sorbate is tested by Mercury Limit Test, its content should not be more than 1.0 ppm.
- (4) Arsenic : It should be no more than 4.0 ppm tested by Arsenic Limit Test.
- (5) Aldehyde : To 3.0g of Calcium Sorbate, 450 mL of water is added. The pH of this solution is adjusted to 4 using Hydrochloric acid. Then water is added to make 500 mL and filtered, test solution. Separately, water is added to 2.5mL of 37% formaldehyde solution to make 1,000mL. 3 mL of this solution is precisely measured and water is added to make 500 mL, reference solution. To 5 mL of each of test solution and reference solution, 2.5 mL of puccine sulfite solution is added. Then set aside the solution for 15~30 minutes. The color of test solution should not be deeper than that of reference solution. (not more than 0.1% as formaldehyde).

Loss on Drying When Calcium Sorbate is dried for 3 hours at 105°C, the loss should not be more than 3.0%.

Assay

Dissolve 0.25 g of Calcium Sorbate, previously dried and accurately weighed in 35 mL of glacial acetic acid (for non-aqueous titration) and 4 mL of anhydrous acetic acid by heating in a water bath. After cooling, this solution is titrated with 0.1 N perchloric acid (indicator : 2 drops of crystal violet solution). At the end point, the solution turns green.

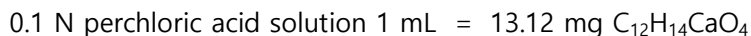

Calcium Stearate

INS No.: 470(i)

CAS No.: 1592-23-0

Definition Calcium Stearate is a mixture of calcium salts of stearic acid and palmitic acid.

Compositional Specifications of Calcium Stearate

Content Calcium Stearate, when calculated on the dried basis, should contain within a range of 9.0~10.5% of calcium oxide (CaO).

Description Calcium Stearate is white ~ yellow powder or slightly glossy crystalline solid or semi solid.

Identification 1 g of Calcium Stearate is dissolved in 25 mL of water and 5 mL of hydrochloric acid, which is then heated. After cooling, a fatty acid layer is separated as supernatant. The lower aqueous layer is evaporated to dryness. The solution residue responds to test of calcium salt in Identification Method.

Purity (1) Free Fatty Acids : Approximately 7 g of Calcium Stearate is precisely weighed into a 250 mL Erlenmeyer Flask, where 75 mL of neutralized warm alcohol and 2 mL of phenolphthalein solution are added. It is then titrated with 0.25 N sodium hydroxide solution until the red color persists for 30 seconds. The content of free fatty acids (as stearic acid) is obtained using the following equation and should not be more than 3.0%.

$$\text{Free Fatty Acids} = \frac{V \times 0.25 \times 28.45}{\text{weight of the sample(g)}}$$

V : Consumed volume (mL) of 0.25 N sodium hydroxide solution

(2) Arsenic : It should be no more than 4.0 ppm tested by Arsenic Limit Test.

(3) Lead : When 5.0 g of Calcium Stearate is tested by Atomic Absorption Spectrophotometry or Inductively Coupled Plasma Emission Spectroscopy, its content should not be more than 1 ppm.

(4) Unsaponifiable : 5 g of Calcium Stearate is precisely weighed into a 250 mL round bottom flask, where 50 mL of 0.5 N potassium hydroxide solution is added and refluxed for 1 hour with a reflux condenser. After heating is finished, 100 mL of water is added through the condenser and the flask is shaken. After cooling, the content is transferred into a separatory funnel with a stop cock. The flask is washed with ether several times (approximately 100 mL), which is added to the funnel. The funnel is shaken vigorously for 1 minute and then settled to separate two phases completely. The supernatant ether layer is collected in a 500 mL separatory funnel with a stop cock. The aqueous layer is again extracted twice with 100 mL of ether. These extracts are added to the first extract. The combined extracts are washed with 25 mL of 10% alcohol. This procedure is repeated until the aqueous layer doesn't get colorized by phenolphthalein solution. When this is accomplished, aqueous phase is

discarded and the ether extract is transferred into a pre-weighed beaker. With 10 mL of ether, the funnel is washed, which is added to the beaker. Ether layer is evaporated to dryness in a water bath, which is then dried at 103°C for 15 minute duration at a time until the weight becomes constant. (If the weight doesn't become constant after 3 trial, the sample might have been contaminated.) Then the residue is cooled in a desiccator and weighed. The residue is dissolved in 4 mL of ether. 20 mL of pre-neutralized alcohol(indicator : sodium hydroxide) is added to the solution. The resulting solution is titrated with 0.1N alcoholic solution of potassium hydroxide until a pale red color persists. The content of unsaponifiables is obtained from the following equation and the content should not be more than 2.0%.

$$\text{Unsaponifiables(\%)} = \frac{[\text{weight of residue matter(g)} - 0.281 \times V \times 0.1]}{\text{weight of the sample(g)}} \times 100$$

V : Consumed amount of 0.1 N potassium hydroxide solution (mL)

Loss on Drying When Calcium Stearate is dried for 3 hours at 105°C, the loss should not be more than 4.0%.

Assay Approximately 1.2 g of Calcium Stearate is precisely weighed, where 50 mL of 0.1 N hydrochloric acid. It is then boiled for 30 minutes while replenishing water occasionally. After cooling, it is filtrated. The residue is washed with water until the filtrate is no longer acidic. This wash water is added to the previous filtrate, which is then titrated with 1 N sodium hydroxide solution. The resulting solution is neutralized (Test Solution). 30 mL of 0.05 M EDTA solution, 15 mL of 1 N sodiumhydroxide solution, and 0.3 g of hydroxynaphtholblue hydroxynaphtholblue (indicator : $\text{C}_{20}\text{H}_{12}\text{O}_{11}\text{S}_3\text{Na}_2$) are added to the Test Solution, which is then titrated with 0.05 M EDTA solution until the solution turns blue.

1 mL of 0.05 M EDTA solution = 2.804 mg CaO

Calcium Stearoyl Lactylate

Chemical Formula:

Molecular Weight:

INS No.: 482(i)

Synonyms: Calcium stearoyl lactate

CAS No.: 5793-94-2

Definition Calcium Stearoyl Lactylate is a mixture having calcium of stearoyl lactylates as a major component of related acids and their calcium salts

Compositional Specifications of Calcium Stearoyl Lactylate

Description Calcium Stearoyl Lactylate is a white ~ yellow powder. It is odorless or has a characteristic scent.

Identification (1) 1 g of Calcium Stearoyl Lactylate is heat-treated for 1 hour at 500°C. The residue is dissolved in 5 mL of hydrochloric acid (1→3). This solution responds to calcium salts.

(2) 2 g of Calcium Stearoyl Lactylate is well mixed with 10 mL of dilute hydrochloric acid, which is heated for 5 minutes in a water bath. It is filtered while hot. 30 mL of sodium hydroxide solution is added to the residue on the filter paper. While shaking, it is heated for 30 minutes in a water bath at 95°C or higher. After cooling, 20 mL of dilute hydrochloric acid is added. The resulting solution is extracted twice with 30 mL each of ether. Ether extracts are combined and washed with 20 mL of water. It is then dehydrated with anhydrous sodium sulfate. Ether is evaporated out in a water bath. The melting point of the residue should be within a range of 54~69°C.

(3) Calcium Stearoyl Lactylate responds to the test for Lactate Salts in Identification.

Purity (1) Acid Value : Approximately 0.5 g of Calcium Stearoyl Lactylate is precisely weighed, 20 mL 1:1 mixture of alcohol and ether is added, (heated and dissolved if necessary) test solution, and proceeded as directed under Acid Value in Fats Test. The acid value should be within a range of 50 ~ 86.

(2) Ester Value : Approximately 1 g is precisely weighed and dissolved in 25 mL of 0.5 N alcoholic solution of potassium hydroxide and 40 mL of toluene, test solution. It is proceeded under Saponification Value and Esther value in Fats Test, and the ester value should be within a range of 125~164.

(3) Arsenic : It should be no more than 4.0 ppm tested by Arsenic Limit Test.

(4) Lead : When 5.0 g of Calcium Stearoyl Lactylate is tested by Atomic Absorption Spectrophotometry or Inductively Coupled Plasma Emission Spectroscopy, its content should not be more than 2.0 ppm.

(5) Cadmium : When 5.0g of Calcium Stearoyl Lactylate is tested by Atomic Absorption Spectrophotometry or Inductively Coupled Plasma Emission Spectroscopy, its content should not be more than 1.0 ppm.

(6) Mercury : When Calcium Stearoyl Lactylate is tested by Mercury Limit Test, its content should not be more than 1.0 ppm.

(7) Total Lactate Content : Calcium Stearoyl Lactylate is tested by following the procedure in Purity (7)

for 「Sodium Stearoyl Lactylate」. Total lactate content should be within a range of 32~38%.

(8) Calcium : Accurately weigh 250 mg of Calcium Stearoyl Lactylate into a beaker and dissolve it in 10 mL of alcohol by heating. This solution is transferred into a 25 mL volumetric flask. The beaker is rinsed twice with ~~two~~ 5 mL portions of alcohol. This alcohol is added to the volumetric flask and alcohol is added so that the total volume is brought up to 25 mL. Test solution is prepared by adding 0.25 mL of that solution, 2.5 mL of lanthanum standard stock solution into a 25 mL volumetric flask, and make 25 mL with water. Measure Atomic absorbance by the use of spectrophotometer by following operation condition. Separately, measure absorbance values of calcium standard solution and prepare a calibration curve. Absorbance of the test solution is substituted to the calibration curve, and the concentration of Calcium C($\mu\text{g}/\text{mL}$) is obtained. Using the equation below, calcium content in Sodium Stearoyl Lactylate is calculated. This value should be within a range of 1.0 ~ 5.2%.

$$\text{Calcium(\%)} = \frac{2.5 \times C}{\text{weight of the sample(mg)}} \times 100$$

Operation Conditions

-Gas used : Combustible gas (acetylene or hydrogen)

Combustible support gas (air)

-Lamp : Cadmium hollow cathode lamp

-Wavelength : 422.7 nm

◦ Standard Solution : To 250 mg of calcium carbonate, add 100 mL of hydrochloric acid (1→10), heat with not boiling, and cool it down. Then water is added to make 1,000 mL. 0.2, 0.4, and 0.5 mL of this solution is added to each 100 mL volumetric flask, 10 mL of lanthanum standard stock solution is added to it, respectively. Then the water is added so that the total volume of each flask becomes 100 mL. (1 mL of the solution contains 2.0, 4.0, and 5.0 μg of sodium, respectively.)

Residues on Ignition When thermogravimetric analysis is done with Calcium Stearoyl Lactylate at 800°C, the amount of residues should be within a range of 14.3 ~ 17.7%.

Calcium Sulfate

Chemical Formula: $\text{CaSO}_4 \cdot 2\text{H}_2\text{O}$

Molecular Weight: 172.27

INS No.: 516

Synonyms: Gypsum

CAS No.: 7778-18-9

Compositional Specifications of Calcium Sulfate

Content Calcium Sulfate should contain within a range of 98.0 ~ 105.0% of calcium sulfate ($\text{CaSO}_4 \cdot 2\text{H}_2\text{O}$).

Description Calcium Sulfate occurs as a white to pale yellow-white powder or crystalline powder.

Identification To 1 g of Calcium Sulfate, add 100 mL of water, shake well, and filter. The filtrate responds to the tests for Calcium Salt and Sulfate in Identification.

Purity

- (1) Clarity and Color of Solution : Weigh 0.2 g of Calcium Sulfate, add 10 mL of diluted hydrochloric acid, and dissolve while heating. The turbidity of test solution should not be more than almost clear.
- (2) Free Alkali : Weigh 0.5 g of Calcium Sulfate, add 100 mL of water, shake, filter, measure 10 mL of the filtrate, and add 1 drop of phenolphthalein solution. No pink color develops.
- (3) Chloride : Weigh 0.2 g of Calcium Sulfate, add 20 mL of water, shake well, filter, and measure 5 mL of the filtrate. 6 mL of diluted nitric acid is added, test solution. The solution tested by Chloride Limit Test, its content should not be more than the amount that corresponds to 0.3 mL of 0.01 N hydrochloric acid.
- (4) Carbonate : Weigh 0.5 g of Calcium Sulfate, add 5 mL of diluted hydrochloric acid. No effervescence occurs.
- (5) Arsenic : It should be no more than 4.0 ppm tested by Arsenic Limit Test.
- (6) Lead : Calcium Sulfate is tested by purity (2) for 「Sodium Metaphosphate」(not more than 2.0 ppm).
- (7) Mercury : When Calcium Sulfate is tested by Mercury Limit Test, its content should not be more than 1.0 ppm.
- (8) Selenium : 0.2 g of Calcium Sulfate is precisely weighed and is tested by purity (6) for 「Sulfuric acid」, (not more than 30 ppm).
- (9) Fluoride : 1 g of Calcium Sulfate is precisely weighed and is tested by purity (8) for 「Calcium Citrate」 (not more than 30 ppm).

Loss on Ignition The loss on ignition of Calcium Sulfate should be within a range of 18 ~ 24%

Assay Accurately weigh about 1 g of Calcium Sulfate, add 40 mL of diluted hydrochloric acid, dissolve while heating on a water bath, cool, and add water to make exactly 100 mL. Take 10 mL of this solution and proceed as directed under Assay for 「Calcium Hydroxide」.

1 mL of 0.05 M EDTA = 8.609 mg of $\text{CaSO}_4 \cdot 2\text{H}_2\text{O}$

Candelilla Wax

INS No.: 902

CAS No.: 8006-44-8

Definition Candelilla Wax is obtained by sampling and purifying stems of candelilla (*Euphorbia Antisyphilitica* ZUCC.) of euphorbiaceae.

Compositional Specifications of Candelilla Wax

Description Candelilla Wax is almost tasteless pale yellow ~ yellowish brown solid with resinous odor.

Identification (1) 1~2 mg of Candelilla Wax is analyzed by Potassium Bromide Disk Method in Infrared Spectrophotometry (1). Its spectrum is shown below.



Purity (1) Melting Point : Melting point of Candelilla Wax should be in a temperature range of 68~73°C.

(2) Acid value : Approximately 3 g of Candelilla Wax is precisely weighted and dissolved in 80 mL mixture of xylan and ethyl alcohol (3 : 5) (Test Solution). When Test Solution is tested by Acid Value Test Methods in Flavoring Substances Test. 12.0~24.0 (titration should be carried out when it is warm.).

(3) Saponification Value : 1 g of Candelilla Wax is precisely weighted into a saponification flask, 50mL of mixture of xylan and ethyl alcohol (3→5) in ethyl alcohol and 25 mL of alcoholic solution of potassium hydroxide are added. After attaching a reflux condenser, the solution is heated for 1 hour while shaking occasionally. Make warm. A few drops of phenolphthalein TS are added to the solution, which is then titrated with 0.5 N hydrochloric acid. Saponification value is calculated using the following equation and should be 43 ~ 65.

(4) Arsenic : It should be no more than 4.0 ppm tested by Arsenic Limit Test.

(5) Lead : When 5.0 g of Candelilla Wax is tested by Atomic Absorption Spectrophotometry or Inductively Coupled Plasma Emission Spectroscopy, its content should not be more than 2.0 ppm.

(6) Mercury : When Candelilla Wax is tested by Mercury Limit Test, its content should not be more than 1.0ppm.

Residue on Ignition Residue on Ignition of Candelilla Wax should not be more than 0.3%.

Capric Acid

Chemical Formula: $C_{10}H_{20}O_2$

Molecular Weight: 172.27

INS No.: 570

Synonyms: Decanoic acid

CAS No.: 334-48-5

Definition Capric acid is a saturated fatty acid obtained from fat and its main ingredient is capric acid ($C_{10}H_{20}O_2$).

Composition Specifications of Capric Acid

Description Capric acid is a white crystal with characteristic smell.

Purity (1) Acid Value : When 0.5 g of Capric acid is precisely weighted, and proceeded as directed under Acid value in Fats Test, the Acid value should be 320~329.

(2) Solidification point : The Solidification point of Capric acid is 27.0 ~ 32.0°C

(3) Lead : When 5.0 g of Capric acid is tested by Atomic Absorption Spectrophotometry or Inductively Coupled Plasma Emission Spectroscopy, its content should not be more than 1.0 ppm.

(4) Arsenic : It should be no more than 4.0 ppm tested by Arsenic Limit Test.

(5) Mercury : When Capric acid is tested by Mercury Limit Test, its content should not be more than 1.0 ppm.

(6) Iodine Value : Approximately 5.9 g of Capric acid is precisely weighted into a 500 mL Erlenmeyer flask with a stopper which contains 20 mL of 1 : 1 mixture of glacial acetic acid : cyclohexane and 25 mL of Weiss solution. A stopper is placed on the flask which is vigorously shaken and set aside for 1 hour in a dark place. 20 mL of potassium iodide solution and 100 mL of water (previously boiled and cooled) are added to the flask. The excess iodine is titrated with 0.1 N sodium thiosulfate solution. 0.1 N sodium thiosulfate solution is added drop wise until yellow color disappears. Starch solution is added and the titration is continued until the blue color disappears completely. Near the end point, the flask is vigorously shaken with a stopper. Separately, a blank test is carried out by the same procedure. Iodine value is obtained by the following equation and it should not be more than 0.6.

$$\text{Iodine Value} = \frac{(B-S) \times 1.269}{\text{weight of the sample(g)}}$$

B : Consumed amount of 0.1 N sodium thiosulfate solution in the blank test (mL)

S : Consumed amount of 0.1 N sodium thiosulfate solution in the test for sample (mL)

(7) Saponification Value : 3 g of Capric acid is precisely weighted into a 250 mL flask, where 50 mL of

0.5 N alcoholic solution of potassium hydroxide is added. After attaching a reflux condenser, the solution is saponified for 30 ~ 60 minutes. This solution is used as test solution, tested under Saponification value in Fats Test, boiled (red color appears again) and titrated again until the red color disappears. Saponification value should be 320~331.

(8) Unsaponifiable Matter : 5 g of Capric acid is precisely weighted into a 250 mL flask, where 2 g of potassium hydroxide and 40 mL of alcohol are added and gently refluxed for 1 hour with a reflux condenser. The solution transferi nto a separatory funnel (3.5 cm diameter × 30 cm length with 40 mL, 80 mL, and 130 mL scale marks) with a stopcock. The flask is washed with sufficient amount of alcohol, which is added to the funnel (total volume = 40 mL). The flask is washed with warm and cold water, which is added to the funnel (total volume = 80 mL). Finally, the flask is washed with a few mL of petroleum ether, which is added to the funnel. Cool the solution, 50 mL of petroleum ether is added to the funnel. The funnel is shaken vigorously for 1 minute and then settled to separate two phases completely. The supernatant ether layer is collected in a 500 mL separatory funnel with a stopcock. The aqueous layer is again extracted 6 times with 50 mL each of ether. These extracts are added to the first extract. The combined extracts are washed with 25 mL of 10% alcohol. This procedure is repeated until the aqueous layer doesn't get colorized by phenolphthalein TS. When this is accomplished, aqueous phase is discarded and the ether extract transfer into a pre-weighted beaker. With 10 mL of ether, the funnel is washed, which is added to the beaker. Ether layer is evaporated to dryness in a water bath, which is then dried at 100°C for 30 minutes until the weight becomes constant. Then the residue is cooled in a desiccator and weighted. The residue dissolve in 50 mL of warm alcohol (neutralized with sodium hydroxide using phenolphthalein as an indicator). The resulting solution is titrated with 0.02 N sodium hydroxide solution until a pale red color persists. The amount of oleic acid is obtained by multiplying the consumed amount of sodium hydroxide solution with 5.659 (mg). The exact amount of unsaponifiables is obtained by subtracting the amount of fatty acid (as oleic acid) from the amount of residues. The content of unsaponifiable matter is calculated by the following equation and it should not be more than 0.2%.

$$\text{Unsaponifiable matter(\%)} = \frac{\text{content of residue(mg)} - \text{content as oleic acid(mg)}}{\text{weight of the sample(g)}} \times \frac{100}{1,000}$$

Water Content Water content of Capric acid proceed as directed under water determination (Karl-Fisher Titration) and should not be more than 0.2%..

Residue on Ignition When Residue on Ignition analysis is done with accurately weighted 10 g of Capric acid, the amount of residue on Ignition should not be more than 0.1%.

Caprylic Acid

Chemical Formula: C₈H₁₆O₂

Molecular Weight: 144.21

INS No.: 570

Synonyms: Octanoic acid

CAS No.: 124-07-2

Definition Caprylic Acid is a saturated fatty acid obtained from fat, whose main ingredient is caprylic acid.

Composition Specifications of Caprylic Acid

Description Caprylic Acid is a colorless oil with slightly unpleasant odor.

Purity (1) Acid Value : When 0.5 g of Caprylic Acid is precisely weighted, and proceeded as directed under Acid value in Fats Test, the Acid value should be 366~396.

(2) Solidification point : The solidification point of Caprylic Acid is 8 ~ 15 °C

(3) Lead : When 5.0 g of Caprylic Acid is tested by Atomic Absorption Spectrophotometry or Inductively Coupled Plasma Emission Spectroscopy, its content should not be more than 1.0 ppm.

(4) Arsenic : It should be no more than 4.0 ppm tested by Arsenic Limit Test.

(5) Mercury : When Caprylic Acid is tested by Mercury Limit Test, its content should not be more than 1.0ppm.

(6) Iodine Value : Approximately 12.5 g of Caprylic Acid is precisely weighted into a 500 mL Erlenmeyer flask with a stopper which contains 20 mL of 1 : 1 mixture of glacial acetic acid : cyclohexane and 25 mL of Weiss solution. A stopper is placed on the flask which is vigorously shaken and set aside for 1 hour in a dark place. 20 mL of potassium iodide solution and 100 mL of water (previously boiled and cooled) are added to the flask. The excess iodine is titrated with 0.1 N sodium thiosulfate solution. 0.1 N sodium thiosulfate solution is added drop wise until yellow color disappears. Starch solution is added and the titration is continued until the blue color disappears completely. Near the end point, the flask is vigorously shaken with a stopper. Separately, a blank test is carried out by the same procedure. Iodine value is obtained by the following equation and it should not be more than 2.0.

$$\text{Iodine Value} = \frac{(B-S) \times 1.269}{\text{weight of the sample(g)}}$$

B : Consumed amount of 0.1 N sodium thiosulfate solution in the blank test (mL)

S : Consumed amount of 0.1 N sodium thiosulfate solution in the test for sample (mL)

(7) Saponification Value : 2 g of Caprylic Acid is precisely weighted into a 250 mL flask, where 50 mL

of 0.5 N alcoholic solution of potassium hydroxide is added. After attaching a reflux condenser, the solution is saponified for 30 ~ 60 minutes. This solution is used as test solution, tested under Saponification value in Fats Test, boiled (red color appears again) and titrated again until the red color disappears. Saponification value should be 366~398.

(8) Unsaponifiable Matter : 5 g of Caprylic Acid is precisely weighted into a 250 mL flask, where 2 g of potassium hydroxide and 40 mL of alcohol are added and gently refluxed for 1 hour with a reflux condenser. The solution transfer into a separatory funnel (3.5 cm diameter 30 cm length with 40 mL, 80 mL, and 130 mL scale marks) with a stopcock. The flask is washed with sufficient amount of alcohol, which is added to the funnel (total volume = 40 mL). The flask is washed with warm and cold water, which is added to the funnel (total volume = 80 mL). Finally, the flask is washed with a few mL of petroleum ether, which is added to the funnel. Cool the solution, 50 mL of petroleum ether is added to the funnel. The funnel is shaken vigorously for 1 minute and then settled to separate two phases completely. The supernatant ether layer is collected in a 500 mL separatory funnel with a stopcock. The aqueous layer is again extracted 6 times with 50 mL each of ether. These extracts are added to the first extract. The combined extracts are washed with 25 mL of 10% alcohol. This procedure is repeated until the aqueous layer doesn't get colorized by phenolphthalein TS. When this is accomplished, aqueous phase is discarded and the ether extract transfer into a pre-weighted beaker. With 10 mL of ether, the funnel is washed, which is added to the beaker. Ether layer is evaporated to dryness in a water bath, which is then dried at 100°C for 30 minutes until the weight becomes constant. Then the residue is cooled in a desiccator and weighted. The residue dissolve in 50 mL of warm alcohol (neutralized with sodium hydroxide using phenolphthalein as an indicator). The resulting solution is titrated with 0.02 N sodium hydroxide solution until a pale red color persists. The amount of oleic acid is obtained by multiplying the consumed amount of sodium hydroxide solution with 5.659 (mg). The exact amount of unsaponifiables is obtained by subtracting the amount of fatty acid (as oleic acid) from the amount of residues. The content of unsaponifiable matter is calculated by the following equation and it should not be more than 0.2%.

$$\text{Unsaponifiable matter(\%)} = \frac{\text{content of residue(mg)} - \text{content as oleic acid(mg)}}{\text{weight of the sample(g)}} \times \frac{100}{1,000}$$

Water Content Water content of Caprylic Acid proceed as directed under water determination (Karl-Fisher Titration) and should not be more than 0.4%.

Residue on Ignition When Residue on Ignition analysis is done with accurately weighted 10 g of Caprylic Acid, the amount of residue should not be more than 0.1%.

Caramel Color

INS No.:

150a(I), 150b(II),

150c(III), 150d(IV)

Synonyms: (I) Plain caramel; Caustic caramel

(II) Caustic sulfite caramel

(III) Ammonia caramel

(IV) Sulfite ammonia caramel

CAS No.: 8028-89-5

Definition There are caramel I, II, III, and IV. Each definition is as follows.

Caramel I: Caramel I is obtained by heating food-grade carbohydrates, i.e. sugars, hydrolyzed starch, and molasses. Or it can be obtained by treating with acids or alkalis (free of ammonium compounds and sulfites) followed by heat treatment.

Caramel II: Caramel II is obtained by treating food-grade carbohydrates, i.e. sugars, hydrolyzed starch, and molasses in the presence of sulfite compounds (ammonium compound free) followed by heat treatment. Or it can be obtained by treating with sulfites, acids, or alkalis (free of ammonium compounds) followed by heat treatment.

Caramel III: Caramel III is obtained by heating food-grade carbohydrates, i.e. sugars, hydrolyzed starch, and molasses in the presence of ammonium compounds, with or without acids or alkalis (free of sulfites).

Caramel IV: Caramel IV is obtained by heating food-grade carbohydrates, i.e. sugars, hydrolyzed starch, and molasses in the presence of both ammonium compounds and sulfite, with or without acids or alkalis (free of sulfites).

Compositional Specifications of Caramel Color

Description Caramel Color is black ~ dark brown liquid, solid or powder having an odor of burnt sugar and refreshing bitter taste.

Identification (1) Solution of Caramel Color(1→100) is brown ~ blackish brown

(2) Appropriate amount of Caramel Color is weighted so that the measured absorption in advance is about 0.5 and added 0.025N of hydrochloric acid to make to 100 mL. If necessary, the solution is centrifuged and the supernatant is used as A solution. 0.2 g of diethylaminoethyl cellulose anion exchange resin (DEAE cellulose) is dissolved in 20 mL of A solution. Then the solution is centrifuged and the supernatant is used as B solution. Using 0.025N hydrochloric acid as a reference solution, absorbance A_A and A_B of A and B solution are measured at the wavelength 560 nm with 1 cm path length. Value of $(A_A - A_B)/A_A$ should be as below.

Caramel Color I should be not more than 0.75, Caramel Color II and IV should be more than 0.75 and Caramel Color III should be not more than 0.5.

(3) (In the case, this applies to Caramel Color I and Caramel Color III only.)

0.2~0.3 g of Caramel Color is weighted and added 0.025N of hydrochloric acid to make to 100 mL. If necessary, the solution is centrifuged and the supernatant is used as C solution. After taking 40 mL of C solution, add 2 g of phosphoryl cellulose and mix it by shaking well. The solution is centrifuged and the supernatant is used as D solution. Using 0.025N hydrochloric acid as a reference solution, absorbance A_C and A_D of C and D solution are measured at the wavelength 560 nm with 1 cm path length. Value of $(A_C - A_D)/A_C$ should be as below.

Caramel Color I should be not more than 0.5, Caramel Color III should be more than 0.5.

(4) (In the case, this applies to Caramel Color II and Caramel Color IV only.)

0.1 g of Caramel Color is weighted and added water to make to 100 mL. If necessary, the solution is centrifuged and the supernatant is used as A solution. After taking 5 mL of A solution, add water to make to 100 mL and the solution is used as B solution. When absorbance A_A of A solution is measured at the wavelength 560 nm with 1 cm path length, use water as a reference solution. Or when absorbance A_B of B solution is measured at the wavelength 280 nm with 1 cm path length, use water as a reference solution. Value of $A_B \times 20/A_A$ should be as below.

Caramel Color II should be more than 50, Caramel Color IV should be not more than 50.

Purity (1) Arsenic : It should be no more than 4.0 ppm tested by Arsenic Limit Test.

(2) Lead : When 5.0 g of Caramel Color is tested by Atomic Absorption Spectrophotometry or Inductively Coupled Plasma Emission Spectroscopy, its content should not be more than 2.0 ppm.

(3) Cadmium : When 5.0 g of Caramel Color is tested by Atomic Absorption Spectrophotometry or Inductively Coupled Plasma Emission Spectroscopy, its content should not be more than 1.0 ppm.

(4) Mercury : When Caramel Color is tested according to Mercury Test, its content should not be more than 0.1 ppm.

(5) Color Value : 100 mg of Caramel color is precisely weighed and dissolved in water to make 100 mL, test solution. If necessary, the solution is centrifuged and the supernatant is used. Absorbance A of this solution is measured with 1 cm cell at 610 nm, using water as a reference. Color value is obtained from the following equation (converted into a solid matter). The contents should be 0.01 ~ 0.6.

$$\text{Color Value} = \frac{A_{610} \times 100}{\text{Content of solid matter (\%)}}$$

※ Content of solid matter

① Liquid samples : 30 g of quartzsand and glass rod are placed in a weighing bottle, which is dried at 60°C and under vacuum of 50 mm/Hg until the weight becomes constant. 1.5 ~ 2.0 g of the sample is precisely weighed into the weighing bottle, mixed well, and dried to constant weight. Solid matter content is calculated by the following equation. Quartz sand (purified quartzsand, particle size : No.40 ~ No.60 mesh) is decomposed by hydrochloric acid and washed with water until it doesn't appear acidity. It is then dried and heat treated before use.

$$\frac{(\text{weight of quartzsand and sample after drying(g)} - \text{weight of quartzsand(g)}) \times 100}{\text{Content of solid matter (\%)}}$$

weight of sample(g)

- ② Powdered or granular samples : It is carried out according to Test for Loss on Ignition. The sample is dried at 60°C and under vacuum of 50 mm/Hg until the weight becomes constant. Solid matter content(%) is calculated by the following equation.

$$\frac{\text{weight of porcelain crucible and sample after drying(g)} - \text{weight of porcelain crucible(g)}}{\text{weight of porcelain crucible and sample before drying(g)} - \text{weight of porcelain crucible(g)}} \times 100$$

※ Calculation of impurities based on color value of 0.1

Using the content of each impurity (nitrogen as ammonia, 4-methyl imidazole, sulfur dioxide, total nitrogen) obtained under the each Compositional Specifications, Cs (conversion to solid matter) is obtained. On the basis of color value 0.1, the content of each impurity is calculated by the following equation.

$$Cs \times 0.1$$

Color Value

$$Cs : \frac{\text{Content of each impurities} \times 100}{\text{Content of solid matter(\%)}}$$

- (6) Total Nitrogen : When Caramel color is tested under Kjeldahl Method in Nitrogen Determination, the amount should not be more than 3.3% (as based on product with color value of 0.1).

- (7) Total Sulfur : 1 ~ 3g of oxide of magnesium or 6.4 ~ 19.2g of acetic acid magnesium, 1 g of sugar, and 50mL of nitric acid are taken to evaporation dish, 5~10 g of Caramel Color is precisely weighed and concentrated in a water bath until it forms paste. Put evaporation dish into muffle's furnace, gently heat (not more than 525°C) until nitrogen dioxide smoke doesn't generate. After cooling evaporation dish, add hydrochloric acid(1→2.5) to this, dissolve, add 5 mL more after neutralizing, filter, and heated until it boils. 5 mL of 10% barium chloride solution is drop-wise added, contrate until it becomes 100 mL, and allowed to stand for 1 night. Filter this with filter paper(5C or its equivalent), put filter paper and residue into a previously weighed crucible, heat-treat until the weight becomes constant, and weigh as barium chloride. When measuring the content of total sulfur, the amount should not be more than 3.5%. (based on the substance whose color value is 0.1). Separately, perform a blank test.

$$\text{Total Sulfur(\%)} = \frac{\text{Content of barium chloride(g)} \times 0.1374}{\text{Weight of Sample(g)}} \times 100$$

(8) Ammoniacal nitrogen (In the case, this applies to Caramel Color III and Caramel Color IV only.): 25 mL of 0.1 N sulfuric acid is added to a 500 mL Erlenmeyer flask. Kjeldahl distillation apparatus is set up so that the end of the condenser delivery tube is immersed beneath the surface of the sulfuric acid solution in the receiving flask. Separately, approximately 2 g of Caramel Color is precisely weighed into a 800 mL Kjeldahl flask for decomposition, where 2 g of magnesium oxide, 200 mL of water, and several boiling chips. The content is dissolved by shaking and the apparatus is quickly connected. It is then boiled and 100 mL of distillate is collected. The tip of the condenser is washed with water, which is added to the distillate. 4 ~ 5 drops of methyl red solution are added to the distillate, which is then titrated with 0.1 N sodium hydroxide, recording the volume, in mL, required as S. Separately, a blank determination is conducted and recorded the volume, in mL, of 0.1 N sodium hydroxide required to neutralized as B. Ammoniacal nitrogen is calculated by the following equation and it should not be more than 0.6%. (for a product with color value of 0.1).

$$\text{Content of Nitrogen as ammonia(\%)} = \frac{(B - S) \times 0.0014 \times 100}{\text{weight of the sample(g)}}$$

(9) Sulfur Dioxide (In the case, this applies to Caramel Color II and Caramel Color IV only.): The following apparatus is used.

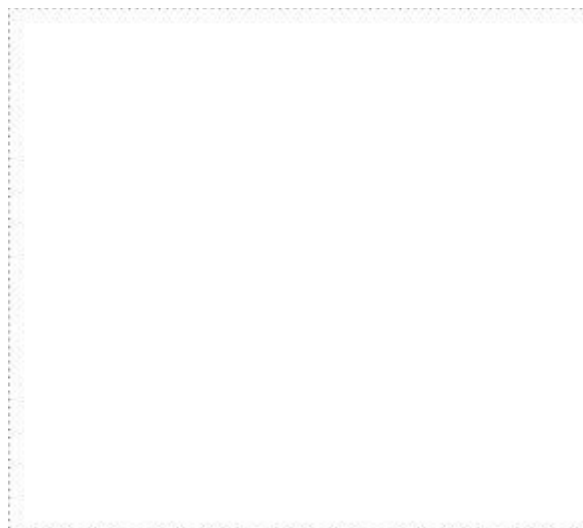

- A : 1,000 mL three neck round bottom flask
- B : 30 cm Allihn reflux condenser
- C : absorption tube
- D : 125 mL separatory funnel with a stopcock
- E : introduction tube

F : 250 mL gas wash bottle connected to a nitrogen cylinder

4.5 g of pyrogallol and 5 mL of water are ground in a small mortar. The supernatant is transferred into a wash bottle. The remaining residue is ground again and washed with water, which is then transferred into the wash bottle. It is passed nitrogen from the cylinder to the bottle to flush out air. Through a long stem funnel, a cooled solution of 65 g potassium hydroxide in 85 mL of water. The wash bottle is again flushed with nitrogen to remove air from the headspace. It is connected to the glass inlet tube of a distillation flask. Gas washing solution is prepared prior to use. Two pieces of glass rods (8 mm diameter ~ 25 mm length) are placed in the absorption tube. 10 mL of glass beads, 10 mL of 3% hydrogen peroxide solution, and 1 drop of methyl red solution are added to the exit side. After the apparatus is connected, the stopcock of the separatory funnel is closed. A small amount of gas is passed through to the apparatus, let stand for a few minutes, and checked for gas leak by equalizing the liquid level.

Test Procedure : 25 g of Caramel color is dissolved in 300 mL of recently boiled and cooled water in a distillation flask. Water is added to bring the total volume to approximately 400 mL. 90 mL of 4 N hydrochloric acid is slowly added to the separator, and force the acid into the flask by blowing gently into the tube in the neck of the separator. Close the stopcock of the separator. In a flowing nitrogen, the solution is brought to a stable reflux and maintained for 2 hours. Then cooling water for the condenser is stopped. When vapor gets condensed in the first absorption tube and the tube gets warm, heating is stopped. When the top connection part of the condenser is cooled, it is disconnected. The first absorption tube is separated from the second one. The solution in the first absorption tube is titrated with 0.1 N sodium hydroxide solution. The connection tube is connected to the exit part of the second absorption tube. The solution is titrated again. The consumed amount of is S. Separately, a blank test is carried out and the volume of 0.1 N sodium hydroxide solution is B. When the content of sulfur dioxide is calculated by the following equation, it should not be more than 0.2% (Based on product with color value of 0.1).

$$\text{Content of Sulfur Dioxide(\%)} = \frac{(S - B) \times 0.0032 \times 100}{\text{weight of the sample(g)}}$$

(10) 4-methylimidazol (In the case, this applies to Caramel Color III and Caramel Color IV only) : 10 g of 4-methylimidazol is taken in 150 mL polypropylene beaker. Add 5 mL of 3N NaOH solution and mix it well to make to be more than pH 12. 20 g of diatomaceous earth(Johns-Manville Celite 545 or its equivalent) for chromatography is taken in a beaker until it is a semi-dried mixture. Then insert it into a 2 cm inner diameter glass tube (including a teflon cock) whose bottom is blocked with a glass fiber and fill the contents to be about 25 cm high. While wash the beaker for previous sample, disemboque ethyl acetate into a glass tube. When a solvent reaches the bottom of the glass tube,

lock a cock and allowed to stand for 5 minutes. Then open the cock and put ethyl acetate in the glass tube and collect a effluent until the total volume of the effluent is about 200 mL. Add 1 mL of the internal standard solution to the effluent, transfer it into flask and concentrate ethyl acetate below 35 °C. Dissolve residue in acetone and take precisely 5 mL of solution, used as test solution. Separately, 0.02 g, 0.06 g, 0.1 g, 0.2 g of 4-methylimidazol is precisely weighted and added precisely 20 mL of the internal standard solution. Then add acetone so that the volume is to be 100 mL. used as separately standard solution. However, the internal standard solution is used the solution which is added with ethyl acetate to 0.05 g of 2-methylimidazol to make precisely to 50 mL. Take 5 μl of test solution and standard solution respectively and do test gas chromatography under below operation conditions. Then measure a peak area of respective standard solution and prepare a calibration curve. The peak area of test solution obtained in the calibration curve should not be more than 250 mg/kg (based on the product whose color value is 0.1)

Operation conditions

Detector: (Hydrogen) Flame ionization detector(FID)

Column: HP-FFAP(25m \times 320 μm \times 0.25 μm) or its equivalent

Column temperature: 180 °C

Temperature at injection hole: 200°C

Carrier gas and flow rate: Nitrogen, 50 mL/min

(11) 2-acetyl-4-tetrahydroxybutylimidazol (In the case, this applies to Caramel Color III): The following apparatus is used.

0.20~0.25 g of 2-acetyl-4-tetrahydroxybutylimidazol is precisely weighted and dissolved in 3 mL of water. Transfer this solution into top part C(connective part of column C and column F) and then wash

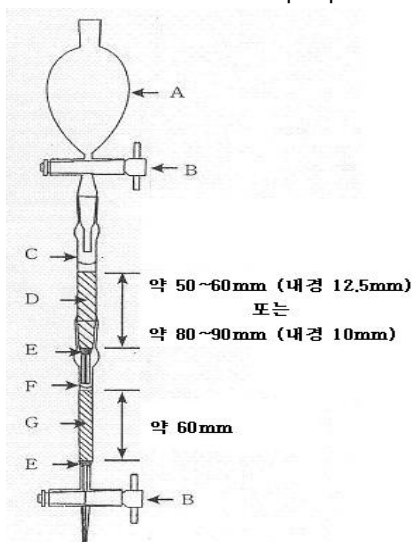

it with 100 mL of water. Continually, remove column C and connect the separatory funnel A to the lower part column F and then elute column F with 0.5 N hydrochloric acid. The first effluent 10 mL is discarded and collect the subsequent effluent to 35 mL and concentrate it at 40 °C,

15 mmHG until it is dried condition. The syrup type residue without carbonyl group is dissolved in 250 μl of methanol. Add 2,4-dinitrophenylhydrazine hydrochloride solution, this reaction mixture is transferred into the glass bottle with cap. Keep it at room temperature for 5 hours and it is used as a test solution. After separately, stirring 0.5 g of 2,4-dinitrophenylhydrazine in 1 mL of hydrochloric acid, add 10 mL of ethanol. And then heat it in water bath until it is solution condition. Add 0.1 g of 2-acetyl-4-tetrahydroxybutylimidazol in hot solution. In a few minutes crystallization of 2-acetyl-4-tetrahydroxybutylimidazol-2,4-dinitrophenylhydrazone (THI-DNPH) begins, cool this until it is room temperature to make the crystallization completely. After adding the small quantity of ethanol to make it to suspension, do filtering it to separate. Refine the crystallized THI-DNPH with ethanol(added with 1 drop of hydrochloric acid per 5 mL of ethanol). After adding the small quantity of ethanol to make the refined crystal to suspension, do filtering it to separate and then dry it in desiccator. Weigh precisely 0.01 g of this item and add methanol without carbonyl group to make to 100 mL. Again this solution is diluted by methanol without carbonyl group to make a standard solution(1 mL of each solution includes 0, 20, 40, 60, 80, 100 μg). Test solution and standard solution respectively and do test liquid chromatography under below operation conditions. Then measure a peak area of respective standard solution and prepare a calibration curve. The peak area of test solution obtained in the calibration curve should not be more than 25 mg/kg (based on the product whose color value is 0.1). However, THI-DNPH 100 $\mu\text{g}/\text{mL}$ corresponds to THI 47.58 $\mu\text{g}/\text{mL}$.

Operation condition

Detector : UV 385 nm

Column : Capcell pak C₁₈(5 μm , 4.6 mm) or its equivalent

Column temperature : Room

Passing of solution : Methanol: phosphoric acid (50:50)

Flow rate : 1.0 mL/min

Solution

2,4-dinitrophenylhydrazine

hydrochloride solution : Put 10 hydrochloric acid into erlenmeyer and then add 5 g of 2,4-dinitrophenylhydrazine. Shake mix it until free base(red color) is

hydrochloride(yellow color). Then after adding 100 mL of ethanol, do heating and melting in water bath. Cool and crystallize it at room temperature and filter it to remove hydrochloride and wash with ether. Dry it at room temperature and keep it in desiccator. This is used as 2,4-dinitrophenylhydrazine hydrochloride. Although hydrochloride can be slowly converted to free base, it can be removed by

- A : Separatory funnel (100mL) mm × 250
- B : Teflon cock
- C : Glass column inner diameter 12.5mm, length 150mm (including the connective part) or inner diameter 10mm, length 200mm (including the connective part) temperature 0.1 M of
- D : Weak acid cation exchange resin (particles)
- E : Cotton mL of
- F : Glass column inner diameter 10mm, length 175mm (including the connective part) flask(100mL)
- G : Strong acid cation exchange resin (particles) silently and converted to

washing with 1,2-dimethoxyethane. 0.5 g of 2,4-dinitrophenylhydrazine hydrochloride is dissolved in 15 mL of 1,2-dimethoxyethane including 5% methanol. And keep it in a refrigerator.

Methanol without carbonyl group : Add 5 g of Girard P reagent and 0.2 mL of hydrochloric acid to 500 mL of methanol. After attaching a reflux condenser to it, distill it for 2 hours. Keep this solution which is sealed in glass bottle.

Carbon Dioxide

Chemical Formula: CO₂

Molecular Weight: 44.01

INS No.: 290

Synonyms: Carbonic acid gas; hydrocarbon gas

CAS No.: 124-38-9

Compositional Specifications of Carbon Dioxide

Content Chlorine dioxide should contain not less than 99.5% of carbon dioxide (CO₂).

Description Chlorine dioxide is a colorless, tasteless and odorless gas or liquid, or white solid(Dry ice).

Identification Chlorine dioxide is fire extinguishing. Pass Carbon Dioxide through calcium hydroxide solution. A white precipitate is formed. Collect the precipitate, and add acetic acid (1→4). It dissolves while effervescence occurs.

Purity The amount of Carbon Dioxide is calculated as the capacity at 20°C and 760 mmHg atmospheric pressure.

(1) Free Acid : 1000 mL of Chlorine dioxide is passed 50 mL of freshly boiled and cooled water into a 50 mL Nestler tube. Insert a gas induction tube (internal diameter : about 1 mm) into the Nestler tube, keep it so that the end is 2 mm from the bottom of the Nestler tube, pass 1,000 mL of Carbon Dioxide in 15 minutes. After passing Chlorine dioxide, add this water to one of two comparison tubes which are same in length. To another comparison tube, add 50 mL of freshly boiled and cooled water and 1 mL of 0.01N hydrochloric acid. To both comparison tubes, add 0.1 mL of methyl orange solution respectively, mix, penetrate, and compare. The color of the solution where the sample is added should not be darker than the color of the tube where 0.01N hydrochloric acid is added.

(2) Hydrogen Phosphide, Hydrogen Sulfide, and Reducing Organic Substances : Transfer 25 mL of silver nitrate-ammonia solution and 3 mL of ammonia solution into a Nestler tube, and pass 1,000 mL of Carbon Dioxide. The color of this solution is not darker than the color of mixture of 25 mL of silver nitrate-ammonia solution and 3 mL of ammonia solution.

(3) Carbon Monoxide : Both ends of a Carbon monoxide detection tube are cut off. One end is connected to a container of Carbon Dioxide and the other end to an appropriate flow meter. When 300 mL of Carbon Dioxide is passed trough at approximately 100 mL/min, the color at the yellow part should not be deeper green than that of a detection tube treated with 300 mL/min of air (Not more than 10 ppm).

Assay For the sampling, proceed in the same manner as directed under Purity. Transfer potassium hydroxide solution (1→3) into a gas pipette with a suitable capacity. Measure exactly no less than 100 mL of Carbon Dioxide in a gas pipette of not less than 100 mL filled with sodium chloride solution (3→10) transfer it into the gas pipette, and shake well. When the volume of the gas that has not been

absorbed becomes constant, measure the volume. Express the volume as V (mL), and calculate the content by the following formula:

$$\text{Content of carbon dioxide(CO}_2\text{)(v/v\%)} = \frac{\text{weight of the sample(mL)} - V(\text{mL})}{\text{weight of the sample(mL)}} \times 100$$

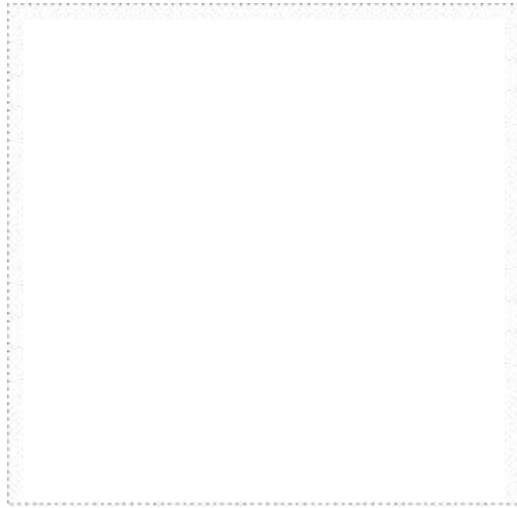

Carmine

INS No.: 120

Synonyms: Carminic acid; Cochineal carmine

CAS No.: 1390-65-4

Definition Carmine is aluminum or calcium-aluminum lake, which is generated by a reaction between aluminum hydroxide and Dactylopius (Carminic acid, $C_{22}H_{20}O_{13}$). Dactylopius is a female coccus cacti which is parasitic on cactus (*Nopalea coccinellifera*).

Compositional Specifications of Carmine

Content Carmine, when calculated on the dried basis, should contain not less than 50.0% as carminic acid ($C_{22}H_{20}O_{13}$ = 492.39).

Description Carmine is red ~ dark red piece, powder, or paste with weak characteristic scent.

Identification To 333 mg of Carmine, add 44 mL of water, 0.15 mL of sodium hydroxide solution (1→10) and 0.2 mL of ammonia water, it is dissolved by heating. Add water to make 500 mL. 10 mL of this solution is diluted to 250 mL with water. The resulting solution shows maximum absorption at 520 nm and 550 nm. Absorption at 520 nm should not be more than 0.3. Water is used as a reference.

Purity (1) Arsenic : It should be no more than 4.0 ppm tested by Arsenic Limit Test.

(2) Lead : When 5.0 g of Carmine is tested by Atomic Absorption Spectrophotometry or Inductively Coupled Plasma Emission Spectroscopy, its content should not be more than 5.0 ppm.

(3) Cadmium : When 5.0 g of Carmine is tested by Atomic Absorption Spectrophotometry or Inductively Coupled Plasma Emission Spectroscopy, its content should not be more than 1.0 ppm.

(4) Mercury : When Carmine is tested by Mercury Limit Test, its content should not be more than 1.0 ppm.

(5) Protein : When Carmine is proceeded as directed under Kjeldahl Method in Nitrogen Determination, its content should not be more than 25% (protein coefficients 6.25)

(6) Salmonella : When Carmine is tested by Salmonella bacillus test of General Test Methods in food codes, it should be negative (-).

Ash 1 g of Carmine is tested by Ash Test Method, the amount of ash should not be more than 12%.

Loss on Drying When 1 g of Carmine is dried for 3 hours at 135°C, the weight loss should not be more than 20%.

Assay Precisely weighed 30 mg of Carmine is dissolved in 30 mL of boiling 2 N hydrochloric acid. The solution is cooled and diluted to 1,000 mL with water (Test Solution). Absorption (A) of the Test Solution is measured with 1cm path length at a maximum absorption wavelength near 495 nm using 0.06 N hydrochloric acid as a reference. The content is calculated using the following equation. However, the weight of the sample is adjusted so that the absorption lies in a range of 0.2 ~ 0.25.

$$\text{Content of Carmine(\%)} = \frac{15A}{\text{Weight of the sample(mg)}} \times \frac{100}{0.262}$$

0.262 : absorption of carminic acid solution (15 mg/l)

Carnauba Wax

INS No.: 903

CAS No.: 8015-86-9

Definition Carnauba Wax is the refined wax obtained from leaves and shoots of the Brazilian tropical palm tree (*Copernicia cereferia* Mart).

Compositional Specifications of Carnauba Wax

Description Carnauba Wax is pale yellow ~ light brown powder, thin platelet, or hard and fragile lump.

Purity (1) Arsenic : It should be no more than 4.0 ppm tested by Arsenic Limit Test.

(2) Lead : When 5.0 g of Carnauba Wax is tested by Atomic Absorption Spectrophotometry or Inductively Coupled Plasma Emission Spectroscopy, its content should not be more than 2.0 ppm.

(3) Mercury : When 0.1 g of Carnauba Wax is tested by Mercury Test Method, its content should not be more than 1.0ppm.

(4) Melting Point : Melting point should be in a temperature range of 80~86°C.

(5) Acid value : 3 g of Carnauba Wax is precisely weighed into a 200 mL Erlenmeyer flask, where 25 mL of anhydrous alcohol (neutralized with potassium hydroxide solution using phenolphthalein solution as an indicator) is added. It is then heated until the sample dissolves, test solution. When the sample solution is tested Acid Value as directed under Acid Value in Oils and Fats Method, Acid Value should be 2 ~ 7.

(6) Ester Value : Ester value is obtained by Fatty Acid method, the value should be 70~80.

(7) Saponification Value : 5 g of Carnauba Wax is precisely weighed into a flask, where 50 mL of 0.5 N alcoholic solution of potassium hydroxide is added. After attaching a reflux condenser, the solution is gently saponified for 30 minutes~ 1 hour. The solution is proceeded as directed under Saponification Value in Oils and Fats Test, the value should be 78 ~ 95.

(8) Unsaponifiable matter : 5 g of Carnauba Wax is precisely weighed into a 250 mL flask, where 2 g of potassium hydroxide and 40 mL of alcohol are added and boiled gently under refluxed for 1 hour with a reflux condenser. The content of flask is transferred to a glass-stoppered extraction cylinder (approximately 30 cm in length, 3.5 cm in diameter and graduated at 40, 80 and 130 mL). The flask is washed with sufficient alcohol to achieve a volume of 40 mL in the cylinder, and completed the transfer with warm and then cold water until the total volume is 80 mL. Finally, the flask is washed with a few mL of petroleum ether, which the washings is added to the cylinder. After cooling to room temperature, 50 mL of petroleum ether is added to the funnel. The funnel is shaken vigorously for at least 1 minute, and allowed both layers to become clear. The supernatant ether layer is collected in a 500 mL separatory funnel with a stopcock. The aqueous layer is repeated extraction at least 6 times with 50 mL portions of petroleum ether. These extracts are added to the first extract. The combined extracts

are washed with 25 mL portions of 10% alcohol until the wash water is neutral to phenolphthalein, and discarded the washings. The ether extract is transferred to a tared beaker. With 10 mL of ether, the funnel is rinsed, which is added to the beaker. Ether layer is evaporated to dryness in a water bath, which is then dried at 100°C for 30 minutes to constant weight. Then the residue is cooled in a desiccator and weighed. The residue is dissolved in 50 mL of warm neutral alcohol and titrated with 0.02 N sodium hydroxide using phenolphthalein as an indicator. Each mL of 0.02 N sodium hydroxide is equivalent to 5.659 mg of fatty acid, calculated as oleic acid. The corrected weight of unsaponifiable matter is obtained by subtracting the calculated weight of fatty acid from the weight of the residues. The content of Unsaponifiable matter is calculated by the following equation and it should be 50~55%.

$$\text{Unsaponifiable matter (\%)} = \frac{\text{Amount of residue(mg)} - \text{amount of oleic acid(mg)}}{\text{Weight of sample (g)}} \times \frac{100}{1,000}$$

Residue on Ignition When Residue on Ignition is done with 2 g of Carnauba Wax in a quartz or platinum crucible, the residue should not be more than 0.25%.

L-Carnitine

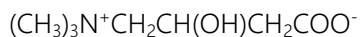

Chemical Formula: $\text{C}_7\text{H}_{15}\text{NO}_3$

Molecular Weight: 161.20

Synonyms: 4-Amino-3-hydroxybutyric acid
trimethylbetaine; Levocarnitine

CAS No.: 541-15-1

Compositional Specifications of L-Carnitine

Content L-Carnitine, when calculated on the dried basis(anhydrous), should contain within a range of 97.0~103.0% L-carnitine ($\text{C}_7\text{H}_{15}\text{NO}_3$).

Description L-Carnitine is white or pale yellow crystalline powder with unique scent.

Identification Infrared absorption spectrum of L-Carnitine is obtained following the procedure in B. (1) Potassium Bromide Disk Method in Infrared Spectrophotometry. It should be show the same spectrum of the standard material.

Purity (1) Sodium : 2 g of L-Carnitine transfer into a 100 mL volumetric flask. After adding 5 mL of nitric acid, it is well mixed and the volume is brought up to 100 mL with water (Test Solution). Using atomic absorption spectrophotometer, the Test Solution and sodium standard solution are analyzed to measure the sodium content in the sample. The content should not be more than 0.1%.

(2) Specific Rotation : Approximately 10 g of L-Carnitine is precisely weighed, which is dissolved in water so that the total volume to make 100 mL. Optical rotation of the solution is measured. When it is translated to dried material, $[\alpha]_D^{20} = -29 \sim -32^\circ$

(3) pH : When pH of L-Carnitine solution (1→20) is measured using glass electrode method, it should be within a range of 5.5~9.5.

(4) Chloride : 0.13 g of L-Carnitine is dissolved in 100 mL of water. To 20 mL of this solution, 6 mL of diluted nitric acid is added (Test Solution). This test solution is tested by Chloride Limit Test. This Test Solution is tested by Chloride Limit Test and its content should not be more than the amount that corresponds to 0.3 mL of 0.01 N hydrochloric acid.

(5) Lead : When 5.0 g of L-Carnitine is tested by Atomic Absorption Spectrophotometry or Inductively Coupled Plasma Emission Spectroscopy, its content should not be more than 1 ppm.

(6) Potassium : 2 g of L-Carnitine transfer into a 100 mL volumetric flask. After adding 5 mL of nitric acid, it is well mixed and the volume is brought up to 100 mL with water (Test Solution). Using atomic absorption spectrophotometer, the Test Solution and sodium standard solution are analyzed to measure the potassium content in the sample. The content should not be more than 0.2%.

Water Content Water content of L-Carnitine is determined by water determination (Karl-Fisher Titration) and should not be more than 4.0%.

Residue on Ignition When thermogravimetric analysis is done with precisely weighed 2 g of L-Carnitine, the amount of residue should not be more than 0.5%.

Assay Approximately 0.1 g of L-Carnitine is precisely weighed and dissolved in 3 mL of formic acid and 50 mL of glacial acetic acid (for non aqueous titration). This solution is titrated with 0.1 N perchloric acid solution (indicator : crystal violet-glacial acetic acid solution). At the endpoint, the color of the solution turns from violet, to blue, and finally to green. Separately, a blank experiment is done following the same procedure.

1 mL of 0.1 N perchloric acid solution = 16.12 mg $C_7H_{15}NO_3$

Carotene

INS No.: 160a(ii), 160a(iv)

Synonyms: Carotenes, mixed

CAS No.: 7235-40-7

Definition Carotene is a collective name of sweet potato carotene, dunaliella carotene, carrot carotene, and palm oil carotene. Its major component is carotene. Sweet potato carotene is obtained by extracting tuberous roots of sweet potato (*Ipomoea batatas* POIR.) of convolvulaceae with organic solvents such as acetone, isopropyl alcohol, methyl alcohol, and hexane. Dunaliella carotene is obtained by extracting *Dunaliella salina* and *Dunaliella bardawil* with carbon dioxide, fats and related substances, or organic solvents such as acetone, isopropyl alcohol, methyl alcohol, and hexane. Carrot carotene is obtained by extracting dried roots of carrot (*Daucus carota* L., etc) of umbelliferae with fats and related substances, or organic solvents such as acetone, isopropyl alcohol, methyl alcohol, and hexane. Palm oil carotene is obtained by adsorptive separation of elaeis (*Elaeis guineensis* JACQ.) palm oil of palmae or extracting the separated unsaponifiable matter with organic solvents such as acetone, isopropyl alcohol, methyl alcohol, and hexane. Dilutant, stabilizer, or solvent can be added for the purpose of color value adjustment and quality preservation.

Compositional Specifications of Carotene

Content Color value ($E_{1cm}^{10\%}$) of Carotene should be more than the indicated value.

Description Carotene is reddish brown ~ venetian red liquid, paste, powder, or paste with a slight characteristic scent.

Identification (1) The solution(1→1,000) of Carotene in the mixture(1:1) of acetone and cyclohexane has orange color and The solution that is added to 1,000 mL of cyclohexane with 0.5 mL of the solution(1→250) of Carotene in the mixture(1:1) of acetone and cyclohexane has a maximum absorption bands near 450 nm and 480 nm.

(2) When 1 mL of antimony trichloride solution is added to a solution of Carotene in cyclohexane (1→100), it becomes bluish green.

Purity (1) Arsenic : It should be no more than 4.0 ppm tested by Arsenic Limit Test.

(2) Lead : When 5.0 g of Carotene is tested by Atomic Absorption Spectrophotometry or Inductively Coupled Plasma Emission Spectroscopy, its content should not be more than 2.0 ppm.

(3) Residual Solvents : When Carotene is tested by Purity (4) for Paprika Extract Pigments, the content of residual solvents should be,

Acetone	Not more than 30ppm
Isopropyl alcohol	Not more than 50ppm
Methyl alcohol	Not more than 50ppm

Hexane

Not more than 25ppm

Assay (Color Value) Appropriate amount of Carotene is precisely weighted so that the absorption is within 0.3 ~ 0.7 and dissolved in 10 mL of 1:1 mixture with acetone and cyclohexane, where cyclohexane is added to bring the total volume to 100 mL. 5 mL of this solution is diluted to 100 mL with cyclohexane. 10 mL of this solution is further diluted to 100 mL with cyclohexane (Test Solution). If necessary, the solution is centrifuged and the supernatant is used. Using cyclohexane as a reference solution, absorption A is measured at the maximum absorption near 455 nm with 1cm path length. Color value is obtained using the following equation (if it is water soluble, water is used).

$$\text{Color Value } (E_{1\text{cm}}^{1\%}) = \frac{A \times 2,000}{\text{Weight of the sample(g)}}$$

β-Carotene



Chemical Formula: C₄₀H₅₆

Molecular Weight: 536.89

Synonyms: CI food orange 5

INS No.: 160a(i), 160a(iii)

CAS No.: 7235-40-7

Definition β-carotene is manufactured by the chemical synthetics, or solvent extracted followed by ethanol, Isopropyl alcohol or ethyl acetate of the fermentation product of *Blakeslea trispora*, and crystallized, which has the trans form of β-carotene as main component.

Compositional Specifications of β-Carotene

Content When β-carotene is dried and weighed, it should contain not less than 96.0% of β-carotene (C₄₀H₅₆).

Description β-carotene occurs as red-purple to dark red crystals or crystalline powder, having a slight, characteristic odor and taste.

Identification (1) β-carotene in cyclohexane solution (1→400) does not have an optical rotation.

(2) To 0.5 mL of a solution of β-Carotene in chloroform (1→250), add 1,000 mL of cyclohexane. The solution exhibits absorbance maxima at wavelengths of 455 ~ 457 nm and 482 ~ 484 nm.

(3) Dissolve 10 mg of β-Carotene in 10 mL of chloroform, which is orange in color, add 1 mL of antimony trichloride solution. A green-blue color develops.

Purity (1) Melting Point : Melting point in sealed tube under reduced pressure should be within a range of 176 ~ 183°C (decomposition).

(2) Clarity and Color of Solution : When 0.1 mL of β-carotene is dissolved in 10 mL of chloroform, the solution should be clear.

(3) Arsenic : It should be no more than 4.0 ppm tested by Arsenic Limit Test.

(4) Lead : When 5.0 g of β-carotene is tested by Atomic Absorption Spectrophotometry or Inductively Coupled Plasma Emission Spectroscopy, its content should not be more than 2.0 ppm.

(5) Absorption Ratio : Accurately weigh about 40 mg of β-carotene previously dried, dissolve in 10 mL of chloroform, and add cyclohexane to make exactly 100 mL. Measure exactly 5 mL of this solution, add cyclohexane to make exactly 100 mL, and use this solution as the test solution. Measure exactly 10 mL of the test solution, add cyclohexane to make exactly 100 mL, and use this solution as the diluted test solution. Measure absorbances A1 and A2 of the test solution at wavelengths of 340 nm and 362 nm, respectively, and absorbances A3, A4, and A5 of the diluted test solution wavelengths of 434 nm, 455 nm, and 483 nm, respectively. A2/ A1 is not less than 1.00, (A4×10)/A1 is not less than

15.0, A4/ A3 is 1.30 ~ 1.60, and A4/ A5 is 1.05 ~ 1.25.

(6) Residual solvent : When β -carotene is tested by Purity (5) for 「Paprika Extract Pigments」, residual ethyl acetate should not be more than 30 ppm, isopropyl alcohol should not be more than 50 ppm(Apply on the case manufactured by *Blakeslea trispora* only).

Loss on Drying When β -carotene is dried for 4 hours in a vacuum desiccator (silica gel), the weight loss should not be more than 1%.

Residue on Ignition When thermogravimetric analysis is done with 2 g of β -carotene, the residues should not be more than 0.1%.

Assay Measure absorbance A at the absorption maximum at a wavelength of 455 ~ 457 nm for the diluted test solution used in Purity (5), and calculate the content of β -carotene by the following formula.

$$\text{Content of } \beta\text{-carotene(\%)} = \frac{A}{2,500} \times \frac{200,000}{\text{Weight of the sample(mg)}} \times 100$$

Storage Standards of β -carotene

Place in a light-resistant, hermetic container, replace the air with inert gas, and store.

Carrageenan

INS No.: 407, 407a

Synonyms: Purified carrageenan; Refined carrageenan;

Semi-refined carrageenan; Processed eucheuma seaweed(PES) CAS No.: 9000-07-1

Definition Carrageenan is obtained by extraction and purification from seaweed of *Chondrus genus*, *Eucheuma genus*, *Gigartina genus*, *Hypnea genus*, and *Iridaea genus* into water or aqueous dilute alkali. The prevalent polysaccharides in carrageena are designated as ι(Iota)-Carrageenan, κ(Kappa)-Carrageenan, and λ(Lambda)-Carrageenan.

Compositional Specifications of Carrageenan

Description Carrageenan is white ~ pale brown powder or granula. It is either odorless or has a slight particular odor.

Identification (1) 4 g of Carrageenan is add to 200 mL of water, and heated the mixture in a water bath at 80°C, with constant stirring, until dissolved. Any water lost by evaporation is replaced, and allowed the solution to cool to room temperature. It becomes viscous and may form gel.

(2) 0.2 g of potassium chloride is added to 50 mL of the solution or gel obtained in (1), then , mixed well, and cooled. A compliant (elastic) gel indicates a carrageenan of predominantly ι-carrageenan, a short-textured(brittle) gel indicates a predominantly κ-carrageenan. If the solution doesn't gel, the carrageenan is of a predominantly λ-carrageenan.

(3) 20 mL of water is added to 0.1 g of Carrageenan, where 3 mL of barium chloride solution (3→25) and 5 mL of diluted hydrochloric acid (3→25) are added and mixed well. If necessary, precipitates are separated. When the separated solution is boiled for 5 minutes, while crystalline precipitates are appeared.

Purity (1) Arsenic : It should be no more than 4.0 ppm tested by Arsenic Limit Test.

(2) Lead : When 5.0 g of Carrageenan is tested by Atomic Absorption Spectrophotometry or Inductively Coupled Plasma Emission Spectroscopy, its content should not be more than 5.0 ppm.

(3) Acid Insoluble Ash : 3 g of Carrageenan is tested by the test method for Ash. When it is converted to a dried basis, the content of ash should not be more than 1.0%.

(4) Sulfate : Carrageenan is dried for 4 hours at 105°C. Approximately 1 g of the dried basis is precisely weighed into a 100 mL round bottom flask, where 50 mL of dilute hydrochloric acid (1→10), a reflux condenser is fitted and reflux for 1 hour. 25 mL of 10 %(by volume) hydrogen peroxide is added to the flask, and resumed refluxing for about 5 hours. If necessary, the solution is filtered. The filtrate is transferred into a 500 mL beaker. While boiling, 10 mL of barium chloride solution (3→25) is slowly added to the beaker, which is heated for 2 hours in a water bath. After cooling, it is filtered through

a quantitative filter paper (5 type C). The residue is washed with warm water until the filtrate is free from chloride. The filter paper and residue is dried in a drying oven. It is gently burned and heat at 800°C ash paper in a tared porcelain crucible until the ash is white. The remaining residue is weighed as barium sulfate. The weight of sulfate (SO₄) is calculated by the following equation. It should be 15.0 ~ 40.0%

$$\text{Content of Sulfate(SO}_4\text{)(\%)} = \frac{\text{Weight of barium sulfate(g)} \times 0.4116}{\text{weight of the sample(g)}} \times 100$$

(5) Viscosity (viscosity of 1.5% solution) : 7.5 g of Carrageenan is weighed into a tared 600 mL tall-form beaker, where 450 mL of water is added. It is then dispersed for 10 ~ 20 minutes by agitation. Water is added to bring the final weight to 500 g, and heated in a water bath with continuous agitation, until a temperature of 80°C is reached. Water is added to adjust for loss by evaporation. It is then cooled to 76 ~ 77°C, and heated in a constant temperature bath at 75°C. It is then tested using a viscometer (Brookfield LVE, LTV type or its equivalent) with a No.1 spindle and capable of rotating at 30rpm. After six complete revolutions of the viscometer, the viscometer reading on 0 ~ 100 scale is taken. When the value is multiplied by 2, it should not be more than 5cps.

(6) Residual solvent : 2 g of Carrageenan is precisely weighed into a 300 mL round bottom distilling flask, 200 mL of water is added, boiling chips and 1 mL of silicone resin are added and mixed well. A fractionating column is connected to flask, 4 mL of internal standard solution is precisely weighed and added to it. While adjusting the heat so that the foam does not enter the column, distill the solution at the rate of 2~3 mL per 1 minute until the milky liquid becomes about 90 mL, and water is added to make 100 mL, test solution. However, tert-butyl alcohol (1→1,000) is used as internal standard solution. Separately, 0.5 g each of methyl alcohol and isopropyl alcohol is precisely measured and water is added to 500 mL. Again 2 mL of this solution and 4 mL of internal standard solution is weighed, water is added to make 100 mL, mixed standard solution. 2μl of test solution and mixed standard solution is taken respectively, and injected to gas chromatograph with the following operation condition. Then, Ratio of methyl alcohol and isopropyl alcohol peak area against tert-butyl alcohol peak area, Q_{T1}, Q_{T2} and Q_{S1}, Q_{S2}, is measured respectively, and measure the content of methyl alcohol and isopropyl alcohol under following equation, it should be not more than 0.1% as individual or sum if used together.

$$\text{Content of methyl alcohol(\%)} = \frac{\text{Weight of methyl alcohol(g)}}{\text{Weight of sample(g)}} \times \frac{Q_{T1}}{Q_{S1}} \times \frac{2 \times 100}{500 \times 100} \times 100$$

$$\text{Content of Isopropyl alcohol(\%)} = \frac{\text{Weight of isopropyl alcohol(g)}}{\text{Weight of sample(g)}} \times Q_{T2} \times \frac{2 \times 100}{500 \times 100} \times 100$$

$$\frac{\text{Weight of sample(g)}}{Q_{S2}} \times 500 \times 100$$

- Q_{T1} : Ratio of methyl alcohol peak area against tert-butyl alcohol peak area in Test Solution
 Q_{T2} : Ratio of isopropyl alcohol peak area against tert-butyl alcohol peak area in Test Solution
 Q_{S1} : Ratio of methyl alcohol peak area against tert-butyl alcohol peak area in mixed standard Solution
 Q_{S2} : Ratio of isopropyl alcohol peak area against tert-butyl alcohol peak area in mixed standard Solution

Column : PLOT Q or its equivalent

Detector : Hydrogen Flame Ionization Detector (FID)

Injection Port Temperature : 200°C

Column Temperature : 120°C

Detector Temperature : 300°C

Carrier gas : Nitrogen or Helium

- (7) Total Viable Aerobic Count : When Carrageenan is tested by Microbe Test Methods for Total Viable Aerobic Count (Number of General Germs) in General Test Method in 「Standards and Specifications for Foods」 it should not be more than 5,000 colonies per 1 g
- (8) E. Coli : When 25 g of Carrageenan is tested by Microbe Test Methods for E. Coli in General Test Method 「Standards and Specifications for Foods」 it should be negative (-).
- (9) Salmonella : When Carrageenan is tested by Microbe Test Methods for Salmonella in General Test Method 「Standards and Specifications for Foods」 it should be negative (-).

Ash 2 g of Carrageenan is precisely weighed and tested by test methods for Ash. When is converted to a dried material, the content of the ash should be not less than 15.0 and not more than 40.0%.

Loss on Drying When 3 g of Carrageenan is dried for 4 hours at 105°C, the weight loss should not be more than 12%.

Carthamus Red

Definition This is a pigment obtained by removing yellow pigment from ornamental flower of carthamus (*Carthamus tinctorius* Linné) of compositae followed by extracting with weakly alkaline water. Its major pigment component is carthamine. Dilutant, stabilizer, or solvent can be added for the purpose of color value adjustment and quality preservation.

Compositional Specifications of Carthamus Red

Content Color value($E_{1\text{cm}}^{10\%}$) of Carthamus Red should not be less than the indicated value.

Description Carthamus Red is dark red ~ dark violet crystallite or powder with a slight characteristic scent.

Identification (1) A solution of Carthamus Red in dimethylformamide shows red color and a maximum absorption band near 530 nm.

(2) When a mixture of 5 mg of Carthamus Red in 50 mL of water is alkalinized with sodium hydroxide solution (1→25), it shows dark yellow color. When it is acidified with hydrochloric acid, it changes to red.

Purity (1) Arsenic : It should be no more than 4.0 ppm tested by Arsenic Limit Test.

(2) Lead : When 5.0 g of Carthamus Red is tested by Atomic Absorption Spectrophotometry or Inductively Coupled Plasma Emission Spectroscopy, its content should not be more than 5.0 ppm.

Assay (Color Value)

Appropriate amount of Carthamus Red is precisely weighted so that the absorption is within 0.3 ~ 0.7. Pigment is eluted with 100 mL of dimethylformamide, which is then filtered. The residue on the filter paper is washed with dimethylformamide, which is added to the filtrate. The filtrate is diluted to 200 mL with dimethylformamide, and use it as Test Solution. Using dimethylformamide as a reference solution, absorption A of Test Solution is measured at the maximum absorption near 530 nm with 1cm path length. Color value is calculated from the following equation

$$\text{Color Value}(\mathbf{E}_{1\text{cm}}^{10\%}) = \frac{A \times 20}{\text{weight of the sample(g)}}$$

Carthamus Yellow

Synonyms: Safflower yellow

Definition This is a pigment obtained by extracting ornamental flower of carthamus (*Carthamus tinctorius* Linné) of compositae with water. Its major pigment component is safflower yellow. Dilutant, stabilizer, or solvent can be added for the purpose of color value adjustment and quality preservation.

Compositional Specifications of Carthamus Yellow

Content Color value ($E_{1cm}^{10\%}$) of Carthamus Yellow should not be less than the indicated value.

Description Carthamus Yellow is yellow ~ dark brown liquid, solid, powder, or paste with a slight characteristic scent.

Identification (1) Test Solution obtained in Color Value section shows yellow color and a maximum absorption band near 403 nm.

(2) 3 mL of Fehling solution is added to an aqueous solution containing 0.1 g of Carthamus Yellow. When the solution is heated for 10 minutes in a water bath, red precipitates are formed.

Purity (1) Arsenic : It should be no more than 4.0 ppm tested by Arsenic Limit Test.

(2) Lead : When 5.0 g of Carthamus Yellow is tested by Atomic Absorption Spectrophotometry or Inductively Coupled Plasma Emission Spectroscopy, its content should not be more than 5.0 ppm.

Assay (Color Value) Appropriate amount of Carthamus Yellow is precisely weighted so that the absorption is within 0.3 ~ 0.7 and dissolve the sample in acetic acid sodium acetate buffer solution with pH 5.28 (total volume 100 mL). 1mL of this solution is diluted to 100 mL with acetic acid sodium acetate buffer solution with pH 5.28 (Test Solution). If necessary, the solution is centrifuged and the supernatant is used. Using acetic acid sodium acetate buffer solution with pH 5.28 as a reference solution, absorption A is measured at the maximum absorption near 403 nm with 1cm path length. Color value is obtained using the following equation.

$$\text{Color Value } (E_{1cm}^{10\%}) = \frac{A \times 1,000}{\text{weight of the sample(g)}}$$

• Citric acid-dibasic sodium phosphate buffer solution (pH 5.28)

Solution 1 : Dissolve 21.01 g of citric acid ($C_6H_8O_7 \cdot H_2O$) into 1ℓ of 0.1 M citric acid solution

Solution 2 : Dissolve 71.63 g of dibasic sodium phosphate ($Na_2HPO_4 \cdot 2H_2O$) into 1ℓ of 0.2 M dibasic sodium phosphate solution

Solution 1 and Solution 2 are mixed well (97:103) and its pH is adjusted to 5.28.

Casein

Definition There are casein and rennet casein. Respective definition is as follows.

Casein : It is obtained by treating a protein from milk or defatted milk with acid.

Rennet casein : It is obtained by treating a protein from milk or defatted milk with rennet.

1. Casein

Compositional Specifications of Casein

Content Casein, when dried, contains 13.8~16.0% of nitrogen (N = 14.01).

Description Casein is white ~ pale yellowish white powder, granules, or flakes. It is odorless and tasteless, or has a slight characteristic odor and taste.

Identification (1) 0.1 g of Casein is dissolved in 10 mL of sodium hydroxide solution, and added acetic acid to make weak acidity, white cotton-like precipitate is formed.

(2) 0.1 g of Casein is dissolved in 10 mL of sodium hydroxide solution, added 1 drop of cupric sulfate solution, and shake. A blue precipitates is formed, and the colour of the solution is purple.

(3) When 0.1 g of Casein is ignited, fume and a characteristic odor is developed. After the fume are no longer evolved, stop heating, and cooled. To the black residue, added 5 mL of dilute nitric acid, dissolved while warming, and filtered. To the filtrate, added 1 mL of ammonium molybdate TS, and warmed. A yellow precipitate is formed.

Purity

(1) Clarity of Solution : Casein is dried in a vacuum desiccator for 4 hours and made into a fine powder. 0.1 g of dried fine powder is mixed by shaking in 30 mL of water, and allowed to stand for about 10 minutes, it is dissolved by adding 2 mL of 0.1 N sodium hydroxide solution, dissolved while warming by shaking at 60°C. After cooling, water is added to bring the total volume to 100 mL. The resulting solution should be colorless and slightly turbid.

(2) pH : 1 g of Casein is mixed in 50 mL of water by shaking for 10 minutes. It is then filtered. pH of the filtrate measured by using a glass electrode should be 3.7~6.5.

(3) Water Soluble Substances : 1.5 g of Casein is add 30 mL of water and shaking for 10 minutes, which is then filtered. 20 mL of filtrate is evaporated to dryness and the residue is dried at 100°C to constant weight. Its content should not be more than 10 mg.

(4) Fat : About 2.5 g of Casein is precisely weighed, where 15 mL of diluted hydrochloric acid (27→40) is added. It is then dissolved while gently heating directly, and heated in a water bath for 20 minutes. After cooling, 10 mL of alcohol is added, which is then transferred to a Rohrig tube, added 25 mL of ether, which is vigorously shaken for 1 minute. 25 mL of petroleum ether is added, which is then shaken vigorously for 30 seconds and allowed to stand. The supernatant taken from side branch tube (A) is filtered through a filter paper. The filtrate is collected into a flask that is previously weighed. It is repeated the extraction above two times, using 15 mL ether and 15 mL petroleum ether each time, transferred the upper-layer solution to the flask, and evaporated the ether and petroleum ether on a

water bath. The residue is dried for 4 hours 98~100°C. The content of fat should not be more than 1.5%.

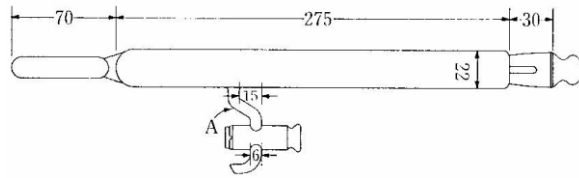

Leriche tube (standard : mm)

(5) Lead : When 5.0 g of Casein is tested by Atomic Absorption Spectrophotometry or Inductively Coupled Plasma Emission Spectroscopy, its content should not be more than 1.0 ppm.

Loss on Drying When Casein is dried for 3 hours at 100°C, the weight loss should not be more than 12%.

Residue on Ignition 1 g of Casein, previously dried, is accurately weighed. When Residue on Ignition is done with it, the amount of residue should not be more than 2.5%.

Assay About 0.15 g of Casein, previously dried, is precisely weighed and proceed as directed in the Kjeldahl Method under Nitrogen Determination.

$$0.1 \text{ N sulfuric acid } 1 \text{ mL} = 1.401 \text{ mg N}$$

2. Rennet Casein

Compositional Specifications of Casein

Content Rennet Casein, when dried, contains 13.5 % of nitrogen (N = 14.01).

Description Rennet Casein is white ~ pale yellowish white powder, flakes, or granules. It is odorless and tasteless, or has a slight characteristic odor and taste.

Identification (1) 0.2 g of Rennet Casein is dissolved in 10 mL of sodium hydroxide solution(1→100)(if necessary, heating), and added 4 mL of diluted acetic acid(1→11). A white cotton-like precipitate is formed.

(2) 0.2 g of Rennet Casein is dissolved in 10 mL of sodium hydroxide solution(1→100)(if necessary, heating), added 1 drop of copric sulfate solution, and shake. A blue precipitates is formed, and the colour of the solution is purple.

(3) When 0.1 g of Rennet Casein is ignited at 450~550°C, fume and a characteristic odor is developed. After the fume are no longer evolved, stop heating, and cooled. To the black residue, added 5 mL of dilute nitric acid, dissolved while warming, and filtered. To the filtrate, added 1 mL of ammonium molybdate TS, and warmed. A yellow precipitate is formed.

Purity (1) pH : 1 g of Rennet Casein is mixed in 50 mL of water by shaking for 10 minutes. It is then filtered. pH of the filtrate measured by using a glass electrode should be 6.0~7.8.

(2) Water Soluble Substances : Rennet Casein is tested as directed under in Purity (3) for Casein, its content should not be more than 10 mg.

(3) Fat : About 2.5 g of Rennet Casein, previously dried at 100°C for 30 minutes and cooled, is precisely weighed. It is tested as directed under in Purity (4) for Casein, its content should not be more than 1.5%.

(4) Lead : When 5.0 g of Rennet Casein is tested by Atomic Absorption Spectrophotometry or Inductively Coupled Plasma Emission Spectroscopy, its content should not be more than 1.0 ppm.

Loss on Drying When Rennet Casein is dried for 5 hours at 105°C, the weight loss should not be more than 13.0%.

Assay About 0.15 g of Casein, previously dried, is precisely weighed and proceed as directed in the Kjeldahl Method under Nitrogen Determination.

0.1 N sulfuric acid 1 mL = 1.401 mg N

Castor oil

INS No.: 1503

Synonyms: Ricinus oil

CAS No.: 8001-79-4

Definition Castor oil is nonvolatile oil obtained from seeds of castor-oil plant (*Ricinus communis* L.) of euphorbiaceae. It is a triglyceride mainly consisting ricinoleic acid.

Compositional Specifications of Castor oil

Description Castor oil is almost colorless or pale yellow viscous liquid.

Identification (1) Castor oil is soluble in 95% alcohol, miscible in anhydrous alcohol, and slightly soluble in petroleum ether.

(2) Specific gravity should be 0.952~0.966.

(3) Refractive Index n_D^{20} should be 1.477~1.481.

Purity (1) Arsenic : It should be no more than 4.0 ppm tested by Arsenic Limit Test.

(2) Lead : When 5.0 g of Castor oil is tested by Atomic Absorption Spectrophotometry or Inductively Coupled Plasma Emission Spectroscopy, its content should not be more than 2.0 ppm.

(3) Acid Value : 5.0 g of Castor oil is precisely weighted and dissolved in approximately 50 mL of alcohol (neutralized with 0.1 N potassium hydroxide solution using phenolphthalein TS) or a mixture of alcohol and ether (1 : 1) (heated if necessary). When this test solution is proceeded as directed under Acid value in Fats Test, the value should not be more than 2.

(4) Hydroxyl Value : 1.5 g of Castor oil is precisely weighted into a 250 mL flask and dissolved by adding 5 mL mixture of pyridine-anhydrous acetic acid (3:1 mixture of freshly distilled pyridine and anhydrous acetic acid). Separately, 5 mL mixture of pyridine-anhydrous acetic acid is added to a 250 mL flask as a blank test. A reflux condenser is attached to each flask. It is then heated for 1 hour in a water bath. 10 mL of water is added through the condenser and it is heated again for 10 minutes. After cooling to room temperature, 15 mL of n-butyl alcohol (neutralized with 0.5 N alcoholic potassium hydroxide solution using phenolphthalein TS) is added through the condenser, the condenser is removed, and inner wall of each flask is washed with 10 mL of n-butyl alcohol. 1 mL of phenolphthalein TS is added to each flask and each solution is titrated with 0.5 N alcoholic solution of potassium hydroxide until it becomes pale red. The consumed amount (mL) of alcoholic solution is S and B for sample and blank test, respectively. Separately, free acid is corrected by the following procedure. 10 g of sample is precisely weighted and dissolved in 10 mL of pyridine (neutralized using phenolphthalein TS and freshly distilled). 1 mL of phenolphthalein TS is added to this solution, which is titrated with 0.5 N alcoholic solution of potassium hydroxide until it becomes red. The consumed amount (mL) of alcoholic solution is A. Hydroxyl value, that is calculated by the following equation, should be 160 ~

168.

$$\text{Hydroxyl Value} = \left[B + \frac{WA}{C} - S \right] \times \frac{28.05}{W}$$

W : Weight of sample for acetylation (g)

C : Weight of sample for free acid measurement (g)

(5) Saponification Value : 3 g is precisely weighted into a 250 mL flask. After adding 50 mL of 0.5 N alcoholic solution of potassium hydroxide, a reflux condenser is attached and quietly saponified for 30 minutes ~ 1 hour. This solution is used as test solution, tested under Saponification value in Fats Test, boiled (red color appears again) and titrated again until the red color disappears. Saponification value should be 176~185.

(6) Iodine Value : Approximately 300 mg of Castor oil is precisely weighted into a 500 mL Erlenmeyer flask with a stopper which contains 20 mL of 1 : 1 mixture of glacial acetic acid : cyclohexane and 25 mL of Weiss solution. A stopper is placed on the flask which is vigorously shaken and set aside for 1 hour in a dark place. 20 mL of potassium iodide solution and 100 mL of water (previously boiled and cooled) are added to the flask. The excess iodine is titrated with 0.1 N sodium thiosulfate solution. Sodium thiosulfate solution is added drop wise until yellow color disappears. Starch solution is added and the titration is continued until the blue color disappears completely. Near the end point, the flask is vigorously shaken with a stopper. Separately, a blank test is carried out by the same procedure. Iodine value is obtained by the following equation and it should be 83 ~ 88.

$$\text{Iodine Value} = \frac{(B-S) \times 1.269}{\text{weight of the sample(g)}}$$

B : Consumed amount of 0.1 N sodium thiosulfate solution in the blank test (mL)

S : Consumed amount of 0.1 N sodium thiosulfate solution in the test for sample (mL)

Catalase

Definition Catalase is an enzyme obtained from cultures of *Aspergillus niger* and its variety and *Micrococcus lysodeikticus*, or liver of cow. Dilutant or stabilizer can be added for the purpose of activity adjustment and quality preservation.

Compositional Specifications of Catalase

Description Catalase is white ~ dark brown powder, granule, paste or colorless ~ dark brown liquid.

Identification When Catalase is proceeded as directed under Activity Test, it should have the activity as Catalase.

Purity (1) Arsenic : It should be no more than 4.0 ppm tested by Arsenic Limit Test.

(2) Lead : When 5.0 g of Catalase is tested by Atomic Absorption Spectrophotometry or Inductively Coupled Plasma Emission Spectroscopy, its content should not be more than 5.0 ppm.

(3) Coliform Group : Catalase is tested by Microbe Test Methods for Coliform Group in General Test Methods in Food Code. It should not be more than 30 cfu per 1 g of this product.

(4) Salmonella : Catalase is tested by Microbe Test Methods for Salmonella in General Test Methods in Food Code. It should be negative (-).

(5) E. Coli : When Catalase is tested by Microbe Test Methods for E. Coli in General Test Method 「Standards and Specifications for Foods」 it should be negative (-).

Activity Test (Activity) Analysis Principle : This test is to measure the activity of catalase declared as Baker units. Activity test is a type of consumption based on decomposition of hydrogen peroxide by catalase and simultaneously on decomposition of catalase by peroxide under the established conditions. Test Procedure : Undiluted enzyme solution (or diluted enzyme solution) is transferred into a 200 mL beaker so that 1.0 mL or less of this solution contains about 3.5 Baker units, where 100 mL of substrate solution (maintained at 25°C) is quickly added and stirred for 5 ~ 10 seconds. The beaker is covered and kept at 25 ± 1°C until the reaction completes. After stirring vigorously for 5 seconds, 4 mL of the solution is precisely taken and transferred into a 50 mL Erlenmeyer flask, where 5 mL of 2 N sulfuric acid is added and mixed. To this solution, 5 mL of freshly prepared 40% potassium iodide solution and 1 drop of 1% ammonium molybdate solution are added. While shaking continuously, the solution is titrated with 0.25 N sodium thiosulfate solution (consumed amount = S). Separately, a blank test is carried out with 4 mL of substrate solution (consumed amount of 0.25 N sodium thiosulfate solution = B). (Note : When the sample is derived from cow liver, the reaction is to complete in 30 minutes. When the sample is derived from *Aspergillus* and others, the reaction is to complete in 1 hour. If the origin is unknown, titration is carried out after 30 minutes at an interval of 10 minutes. If the titration values are same for the two consecutive titration, the reaction is complete.) Enzyme activity is calculated from the following equation.

$$\text{Baker units/g or mL} = 0.4(B - S) \times (1/C)$$

C : Dilution factor for mL of enzyme stock solution added in 100 mL of substrate solution or 1 mL of diluted enzyme solution

Definition of Activity : 1 Baker unit corresponds to the amount of catalase that decomposes 266 mg of hydrogen peroxide under the test conditions above.

Solutions

- 0.25 N Sodium Thiosulfate Solution : 62.5 g of sodium thiosulfate ($\text{Na}_2\text{S}_2\text{O}_3 \cdot 5\text{H}_2\text{O}$) is dissolved in 750 mL of water (previously boiled and cooled), where 3.0 mL of 0.2N sodium hydroxide solution is added as a stabilizer and water is added to bring the total volume to 1,000 mL. It is then standardized by 0.1 N sodium thiosulfate solution. If possible, the normality is adjusted to 0.250.
- Substrate Solution : 25.0 g of sodium phosphate, dibasic (anhydrous) or 70.8 g of sodium phosphate, dibasic (12 hydrates) is added in 1,500 mL of water. pH of the solution is adjusted to 7.0 ± 0.1 with 85% phosphoric acid. 100 mL of 30% hydrogen peroxide is carefully added to the solution and the total volume is brought up to 2,000 mL with water. The resulting solution is transferred into a transparent brown glass bottle, where a cap is loosely placed. If the bottle is filled up to its neck and stored at 5°C, the solution is stable for 1 week or longer. (For a blank test with a freshly prepared substrate solution, approximately 16 mL of 0.25 N sodium thiosulfate solution is consumed. If the consumed amount of 0.25N sodium thiosulfate solution for blank test is 14 mL or less, the substrate solution is unstable. It needs to be prepared freshly. Consumption of enzyme solution should be in a range of 50 ~ 80% of the consumption in the blank).

Storage Standard of Catalase

Catalase is strongly hygroscopic, hence should be stored in sealing tightly at a cold dark place.

Cellulase

Definition Cellulase is an enzyme obtained from cultures of *Aspergillus niger*, *Trichoderma reesei*, *Humicola insolens*, *Penicillium funiculosum* and its variety, respectively. Dilutant or stabilizer can be added for the purpose of activity adjustment and quality preservation.

Compositional Specifications of Cellulase

Description Cellulase is white ~ deep brown powder, particle, paste or colorless ~ deep brown liquid.

Identification When Cellulase is proceeded as directed under Activity Test, it should have the activity as Cellulase.

Purity (1) Arsenic : It should be no more than 4.0 ppm tested by Arsenic Limit Test.

(2) Lead : When 5.0 g of Cellulase is tested by Atomic Absorption Spectrophotometry or Inductively Coupled Plasma Emission Spectroscopy, its content should not be more than 5.0 ppm.

(3) Coliform Group : Cellulase is tested by Microbe Test Methods for Coliform Group in General Test Methods in 「Standards and Specifications for Foods」. It should not be more than 30 cfu per 1 g of this product.

(4) Salmonella : Cellulase is tested by Microbe Test Methods for Salmonella in General Test Methods in 「Standards and Specifications for Foods」. It should be negative (-).

(5) E. Coli : When Cellulase is tested by Microbe Test Methods for E. Coli in General Test Method 「Standards and Specifications for Foods」, it should be negative (-).

Activity Test (activity)

• Analysis Principle : Activity test is based on enzymatic hydrolysis of glucosidic bonding within carboxymethylcellulose substrate (pH 4.5, 40°C). The decrease in viscosity of the substrate is measured by a viscometer with its scale corrected.

• Preparation of Test Solution : Test Solution is prepared by dilution so that 1mL of the final solution shows variation in relative fluidity of 0.18 ~ 0.22 in 5 minutes under the conditions below. Appropriate amount of sample is ground in a glass mortar and water is added. It is diluted in a volumetric flask. It is filtered through a Whatman No.1 filter paper or equivalent prior to use

Test Procedure : A viscometer, scale is previously corrected, is cleanly washed in water with sufficient detergent. It is then set up vertically in a glass water bath at $40 \pm 0.1^\circ\text{C}$. 20 mL of substrate solution and 4 mL of acetate buffer solution are added into a 50 mL Erlenmeyer flask with a stopper (2 for enzyme test and 1 for substrate blank test per sample). An enzyme test flask is plugged with a stopper and maintained for 15 minutes in a water bath, where precisely 1 mL of Test Solution is added and timed. It is then well mixed. Immediately, 10 mL of the mixed solution is added to the big branch of the viscometer. Approximately in 2 minutes, the reaction mixture is sucked in through the thin branch of the viscometer up to the upper scale using a rubber bulb. Time taken to reach the upper scale is measured in minutes (T_R). Again time taken to reach the lower scale (starting from the upper scale) is measured in seconds (T_T). By repeating the same procedure, T_R and T_T are measured again. This is repeated 4 times within

15minutes. Separately, a mixture of 20 mL substrate solution, 4 mL acetate buffer solution and 1 mL water is added. 10 mL of the mixture is taken to the big branch of the viscometer. The time taken to reach the lower scale from the upper scale is measured five times and an average value is obtained T_S (seconds). A water blank test is carried out with 10 mL of water that is maintained at $40 \pm 0.1^\circ\text{C}$ by following the same procedure. An average value of 5 times is obtained, T_W (seconds). Using the following formula, relative fluidity and T_N values are obtained for each of 4 times of effluent time (T_T) and reaction time (T_R).

$$F_R = \frac{T_S - T_W}{T_T - T_W}$$

$$T_N = \frac{1}{2} (T_T / 60\text{sec} / \text{min}) + T_R = \frac{T_T}{120} + T_R$$

F_R : Relative fluidity for each reaction time

T_S : Average effluent time for substrate blank test (seconds)

T_W : Average effluent time for water blank test (seconds)

T_T : Effluent time for enzyme reaction solution (seconds)

T_R : Reaction time (minutes) (time taken from "adding the Test Solution" to "before the measurement of effluent time (T_T)")

T_N : Reaction time (T_R) (minutes) + one half of effluent time for Test Solution (T_T) (minutes)

A standard curve is prepared using the 4 relative fluidity (F_R) values for the 4 reaction times (T_N). This should be a straight line. The slope corresponds to the change in relative fluidity per minute and is proportional to the amount of enzyme. The optimum slope passing through a series of the test points is a better basis for the enzyme activity than a single value of relative fluidity. F_R values at 10 and 5 minutes are measured from the standard curve. The difference in fluidity should be 0.18 ~ 0.22. The enzyme activity is obtained from the following formula.

$$\text{CU/g} = \frac{1,000(F_{R10} - F_{R5})}{W}$$

F_{R10} : Relative fluidity at reaction time of 10 minutes

F_{R5} : Relative fluidity at reaction time of 5 minutes

1,000 : Conversion factor (g to mg)

W : Amount of sample contained 1mL of Test Solution (mg)

Definition of Activity : 1 Cellulase unit(CU) is a activity which generates a change of 1 in relative fluidity in 5 minutes under the above test conditions on a carboxymethylcellulose substrate.

Apparatus

- Viscometer : Cannon Fenske Type Viscometer with size 100 corrected scale or its equivalent.
- Glass water bath : Isothermal glass water bath at $40 \pm 0.1^{\circ}\text{C}$ or its equivalent.

Agents and Solutions

- Acetate Buffer Solution (pH 4.5) : pH of 400 mL of 0.4 N acetic acid is adjusted to 4.5 ± 0.05 by adding 0.4 N of sodium acetate solution with stirring continuously.
- Sodium Carboxymethylcellulose : Sodium carboxymethylcellulose cellulose gum, Hercules(Aqualon) Type 7HF or its equivalent is used.
- Substrate Solution : 200 mL of water is added to a mixing container and the mixer is set at a low speed. 1g of sodium carboxymethylcellulose is carefully added so that it doesn't splash out and dispersed in water. Using a rubber policeman, contained wall is washed with warm water. The container is covered and the dispersion is mixed for 1 minute at high speed. The mixture is transferred into a 500 mL volumetric flask and the total volume is brought up to 500 mL with water. Substrate solution is filtered through a gauze prior to use.

Storage Standard of Cellulase

Cellulase should be stored in a hermetic container in a cold dark place.

Cellulose, Microcrystalline

INS No.: 460(i)

Synonyms: Cellulose gel

CAS No.: 9004-34-6

Definition Cellulose, Microcrystalline is obtained from wood pulp. Its major component is Cellulose, Microcrystalline.

Compositional Specifications of Cellulose, Microcrystalline

Content If Cellulose, Microcrystalline is converted to an anhydrous form, it should contain 97.0~102.0% of hydrocarbons as cellulose.

Description Cellulose, Microcrystalline is white ~ grayish white fluidity crystalline powder. It is odorless.

Identification (1) 30 g of Cellulose, Microcrystalline is added to 270 mL of water, which is stirred for 5 minutes at approximately 3,000 rpm. This is transferred into a 100 mL mass cylinder, which is allow to stand for 3 hours. The resulting liquid is white opaque dispersion without bubbles. Separation of phases should not be observed.

(2) 0.1N iodine solution is added to 1 mg of Cellulose, Microcrystalline, which is heated for 30 minutes in a water bath. To this solution, 4 mL of catechol-phosphoric acid solution (1→500) is added and heated for 30 minutes. The color of the resulting solution appears red.

Purity (1) Arsenic : It should be no more than 4.0 ppm tested by Arsenic Limit Test.

(2) Lead : When 5.0 g of Cellulose, Microcrystalline is tested by Atomic Absorption Spectrophotometry or Inductively Coupled Plasma Emission Spectroscopy, its content should not be more than 2.0 ppm.

(3) Cadmium : When 5.0 g of Cellulose, Microcrystalline is tested by Atomic Absorption Spectrophotometry or Inductively Coupled Plasma Emission Spectroscopy, its content should not be more than 1.0 ppm.

(4) Mercury : When 0.1 g of Cellulose, Microcrystalline is tested by Mercury Test Method, its content should not be more than 1.0 ppm.

(5) Starch : When 2 drops of iodine TS are added to 30 mL of Test Solution in Identification (1), it should not become bluish violet ~ blue.

(6) pH : 5 g of Cellulose, Microcrystalline is well mixed for 20 minutes with 40 mL of freshly boiled and cooled water. It is then centrifuged. pH of the supernatant should be 5.5~7.0.

(7) Water Solubles : 5 g of Cellulose, Microcrystalline is added to 80 mL of water, which is shaken for 10 minutes. This is filtered through a No.42 Whatman filter paper or its equivalent into a beaker that make previously constant weight. The filtrate is evaporated, which is then dried for 1 hour at 105°C. The residue should not be more than 0.24%.

Loss on Drying When 1 g of Cellulose, Microcrystalline is dried for 3 hours at 105°C, the weight loss should not be more than 5%.

Residue on Ignition When Residue on Ignition is done with 2 g of Cellulose, Microcrystalline, the amount

of residue should not be more than 0.05%.

Assay 125 mg of Cellulose, Microcrystalline is precisely weighed and transferred into a 300 mL Erlenmeyer flask using 25 mL of water. 50 mL of 0.5 N potassium bichromate solution is well mixed and 100 mL of sulfuric acid is carefully added, which is then boiled. After cooling for 15 minutes at room temperature and further cooled in a water bath. The resulting solution is transferred into a 250 mL volumetric flask and filled with water. 50 mL of the resulting solution is titrated with 0.1 N ammonium ferrous sulfate solution using 2 ~ 3 drops of o-phenanthroline as an indicator, its consumption is S (mL) Separately, a blank test is carried out and the consumption of 0.1N ammonium ferrous sulfate solution is B (mL). The content of cellulose in the sample is calculated from the following equation.

$$\text{Content of cellulose(\%)} = \frac{(B-S) \times 338}{W}$$

W : Weight of sample as a dehydrated form (mg)

Cellulose, Powdered

INS No.: 460(ii)

CAS No.: 9004-34-6

Definition Cellulose, Powdered is cellulose obtained by hydrolyzing pulp. The major component is cellulose.

Compositional Specifications of Cellulose, Powdered

Content What Cellulose, Powdered is converted to a dehydrated form, contain 97.0% ~102.0% of carbohydrate, calculated as cellulose.

Description Cellulose, Powdered is white odorless powder.

Identification (1) 10 g of Cellulose, Powdered in 90 mL of water is boiled for 5 minutes. While hot, it is filtered through ashless filter paper. When 2 drops of iodine TS are added to the filtrate, the color does not change from yellow-red.

(2) 2 to 5 mg of Cellulose, Powdered is added to 20 mL of 0.1% solution of anthrone in 75% sulfuric acid and heated in a water bath. The solution turns blue-green within 5 minutes.

(3) 30 g of Cellulose, Powdered is mixed in 270 mL of water with a high speed stirrer at 8,000~8,500 rpm for 5 minutes. The mixture will be either a free-flowing suspension or heavy, lumpy suspension. In the latter case, precipitates are slightly formed and the suspension contains inhomogeneously dispersed air bubbles. If the sample mixture is not free-flowing suspension, 100 mL of the mixture is transferred into a 100 mL graduated cylinder, which is then allow it to settle for 1 hour. Solid phase settles at the bottom and a supernatant liquid appears above the layer of cellulose.

(4) When a few drops of sample mixture obtained from (3) are observed at 100 magnification with a microscope, fibers and fiber fragments are visible, regardless of the degree of fineness of the sample.

Purity (1) Arsenic : It should be no more than 2.0 ppm tested by Arsenic Limit Test.

(2) Lead : When 5.0 g of Cellulose, Powdered is tested by Atomic Absorption Spectrophotometry or Inductively Coupled Plasma Emission Spectroscopy, its content should not be more than 2.0 ppm.

(3) Cadmium : When 5.0 g of Cellulose, Powdered is tested by Atomic Absorption Spectrophotometry or Inductively Coupled Plasma Emission Spectroscopy, its content should not be more than 1.0 ppm.

(4) Mercury : When 0.1 g of Cellulose, Powdered is tested by Mercury Test Method, its content should not be more than 1.0 ppm.

(5) Chloride : Approximately 5 g of Cellulose, Powdered is accurately weighed and transferred into a 500 mL Erlenmeyer flask, where 250 mL of water is added. It is then refluxed for 1 hour and filtered. The filtered sample with 200 mL of water is refluxed for 30 minutes and then filtered. This filtrate is combined to the previous filtrate and hot water rinses, where 1 mL of nitric acid is added. After boiling the resultant mixture, 5 mL of 5% solution of silver nitrate is slowly added. After the precipitate has

coagulated, it is filtered through a glass filtering funnel. The precipitates are washed with diluted nitric acid (1→100) until free from silver nitrate and rinsed with water, dried at 130°C, and weighed. To obtain an corrected weight of the precipitate, a blank determination performed for correction. 1 mg of precipitate is equivalent to 0.247 mg of Cl. The content of Cl should not be more than 0.05%.

(6) pH : 10 g of Cellulose, Powdered is dissolved in 90 mL of water and allow to stand with occasional stirring for 1 hour. The pH of the supernatant liquid is measured with a glass electrode. It should be between 5.0 and 7.5.

(7) Water Solubles : 6 g of Cellulose, Powdered is mixed to 90 mL of recently boiled and cooled water and allowed to stand with occasional stirring for 10 minutes. It is then filtered. First 10 mL of filtrate is discarded and passed the filtrate through the same filter paper a second time, if necessary. 15 mL portion of the filtrate is evaporated to dryness. The residue is further dried at 105°C for 1 hour. The content should not be more than 1.5%.

Ash Approximately 3 g of Cellulose, Powdered is accurately weighed and heated until completely charred at 550 ± 50°C. It is then ignited at 800 ± 25°C until free from carbon. The amount of ash should not be more than 0.3%.

Loss on Drying 3 g of Cellulose, Powdered is dried at 105°C. The loss on drying should not be more than 7%.

Assay Approximately 125 mg of Cellulose, Powdered is accurately weighed and transferred into a 300 mL Erlenmeyer flask. The weighing boat is rinsed with 25 mL of water, which is added to the flask. 50 mL of 0.5 N potassium dichromate solution is added to the flask and 100 mL of sulfuric acid is carefully added. It is then heated to boiling, allowed the solution to stand at room temperature for 15 minutes, and cooled it in a water bath. Water is added to bring the total volume to 250 mL. 50 mL of the resultant solution is titrated with 0.1 N ferrous ammonium sulfate solution (indicator : 3 drops of o-phenanthroline TS). Separately, a blank test is performed, where the consumed amount of 0.1 N ferrous ammonium sulfate solution is B(mL). The normality (N) of 0.1 N ferrous ammonium sulfate solution is obtained by the following formula.

$$\text{Normality (N)} = 0.1 \times 50/B$$

The content of the cellulose in the sample is obtained by the following formula.

$$\text{Cellulose content(\%)} = 6.75(B-S) \times \frac{N}{2W}$$

S : Volume(mL) of 0.1 N ferrous ammonium sulfate solution used in the sample titration

W : Weight(g) of the sample taken, on the dried basis

Chitin

Definition Chitin is obtained by treating shells of crustacea with acids. Its component is *N*-Acetylglucosamine.

Compositional Specifications of Chitin

Description Chitin is white ~ pale yellow or red powder or scale with a slight characteristic scent.

Identification When 5 mL of anthrone solution and 1 mL of water are added to 0.2 g of Chitin, which is heated in a water bath, it becomes blue ~ green.

Purity (1) Arsenic : It should be no more than 4.0 ppm tested by Arsenic Limit Test.

(2) Lead : When 5.0 g of Chitin is tested by Atomic Absorption Spectrophotometry or Inductively Coupled Plasma Emission Spectroscopy, its content should not be more than 2.0 ppm.

Loss on Drying

When Chitin is dried for 4 hours at 105°C, the weight loss should not be more than 15%.

Residue on Ignition

Residue on Ignition of Chitin (converted to dried form) should not be more than 5%.

Chitosan

Definition Chitosan is obtained by alkali treating from chitin. Its component is polyglucosamine.

Compositional Specifications of Chitosan

Description This is white ~ pale yellow or red powder or scale shaped material having a slight characteristic odor.

Identification When 5 mL of anthrone solution and 1 mL of water are added to 0.2 g of Chitosan, which is heated in a water bath, it turns blue ~ green.

Purity (1) Arsenic : It should be no more than 4.0 ppm tested by Arsenic Limit Test.

(2) Lead : When 5.0 g of Chitosan is tested by Atomic Absorption Spectrophotometry or Inductively Coupled Plasma Emission Spectroscopy, its content should not be more than 10.0ppm

(3) Degree of Deacetylation : 0.5 g of dried Chitosan is precisely weighed and dissolved in 5 v/v% acetic acid to make 100 mL. 1 mL of this solution is diluted with 30 mL of water in a 200 mL Erlenmeyer flask. It is titrated with 0.0025 N polyvinyl potassium sulfate solution (indicator: 2 ~ 3 drops of 0.1% toluidine blue solution). The degree of deacetylation is obtained from the following equation. It should not be less than 70.0%.

$$\text{Degree of Deacetylation(\%)} = \frac{X/161}{X/161 + Y/203} \times 100$$

$$X = \frac{1}{400} \times \frac{1}{1,000} \times f \times 161 \times v$$

$$Y = 0.5 \times \frac{1}{100} - X$$

v : Consumed amount of 0.0025 N polyvinyl potassium sulfate solution (mL)

f : Normality factor of 0.0025N polyvinyl potassium sulfate solution

Loss on Drying When Chitosan is dried for 4 hours at 105°C, the weight loss should not be more than 15%.

Residue on Ignition When Residue on Ignition is done with Chitosan (on dried basis), the amount of residue should not be more than 5%.

Chitosanase

Definition Chitosanase is an enzyme obtained from cultures of *Aeromonas* genus, *Bacillus* genus, or *Trichoderma viride*. Diluent or stabilizer can be added for the purpose of activity adjustment and quality preservation.

Compositional Specifications of Chitosanase

Description Chitosanase is white ~ dark brown powder, particle, paste or colorless ~ dark brown liquid.

Identification When Chitosanase is proceeded as directed under Activity Test, it should have the activity as Chitosanase.

Purity (1) Arsenic : It should be no more than 4.0 ppm tested by Arsenic Limit Test.

(2) Lead : When 5.0 g of Chitosanase is tested by Atomic Absorption Spectrophotometry or Inductively Coupled Plasma Emission Spectroscopy, its content should not be more than 5.0 ppm.

(3) Coliform Group : When Chitosanase proceed as directed under Microbiological Methods for Coliform Group in General Testing Methods in 「Standards and Specifications for Foods」. It should contain 30 or less per 1 g of this product.

(4) Salmonella : When Chitosanase proceed as directed under Microbiological Methods for Salmonella in General Testing Methods in 「Standards and Specifications for Foods」. It should be negative (-).

(5) E. Coli : When Chitosanase is tested by Microbe Test Methods for E. Coli in General Test Method 「Standards and Specifications for Foods」, it should be negative (-).

Activity Test (activity)

- Analysis Principle : Activity test is based on hydrolysis of chitosan substrate (pH 5.0, 48°C). Glucosamine, a reducing sugar that is produced by hydrolysis, is reacted with alkaline ferricyanide solution and absorption of the reaction mixture is measured.
- Preparation of Test Solution : sample dissolve in 0.05 M acetate buffer solution so that the absorption difference between 1 mL of the final dilution and enzyme blank test solution is within 0.1 ~ 0.5 under the given test conditions.
- Test Procedure : 2 mL of substrate solution is placed in a test tube, where exactly 1 mL of Test Solution, which is previously isothermalized for 5 minutes in a 48°C water bath, is added, mixed by shaking, and set aside in the water bath. After exactly 5 minutes, the test tube is heated for 3 minutes in a boiling water bath to stop the enzyme reaction and cooled to room temperature. Separately, an enzyme blank test solution is prepared by using 1 mL of Test Solution which is previously deactivated by heating for 3 minutes in a water bath. Separately, 1.4 mL each of water is added to two test tubes. 0.1 mL of enzyme reaction solution and 0.1 mL of enzyme blank test solution is added to respective test tube. 2 mL of alkaline ferricyanide solution is added to each test tube, which is heated for 15 minutes in a boiling water bath and cooled to room temperature. Absorptions of enzyme Test Solution and enzyme blank test solution are measured at 420 nm with 1cm path length. Concentration of D-glucosamine ($\mu\text{mol/mL}$) is obtained from a standard curve.

Standard Curve

D-glucosamine hydrochloride 215.6 mg of pre-dried to a constant weight dissolve in water (total volume = 100 mL). Using this solution, glucosamine standard solutions are prepared so that 1 mL of each solution contains 2.0, 4.0, 6.0, 8.0, and 10.0 $\mu\text{mol/mL}$ of D-glucosamine, respectively. 1 mL of each standard solution and 2 mL of water are added to a test tube, which is boiled for 3 minutes in a boiling water bath and cooled to room temperature. The same procedure described below Separately, 1.4 mL each of water is added to two test tubes. in Test Procedure is followed. Separately, a reference solution is prepared using 1 mL of water instead of 1 mL of Standard Solution. Using this reference solution, absorptions of Standard Solutions are measured at 420 nm with 1cm path length. A calibration curve of absorption vs. concentration of glucosamine standard ($\mu\text{mol/mL}$) is prepared.

Enzyme activity is calculated by the following equation.

$$\text{CU/mL or g} = \frac{A}{5 \times W}$$

A : Concentration of D-glucosamine in Test Solution obtained from the standard curve ($\mu\text{mol/mL}$)

5 : Reaction time (minutes)

W : Amount of sample contained in 1 mL of Test Solution (mL)

Definition of Activity : 1 Chitosanase Unit(CU) corresponds to an amount of enzyme that frees reducing sugar (equivalent of 1 μmol of D-glucosamine) per minute under the test conditions above

Solutions

- 0.05 M Acetate Buffer Solution : 14.8 mL of 0.1 M acetic acid and 35.2 mL of 0.1 M sodium acetate solution are mixed and diluted to 100 mL with water. pH of this solution should be 5.0.
- Substrate Solution : 0.2 g of chitosan (Sigma-Aldrich Co. or its equivalent) is dispersed in 40 mL of water, which is then dissolved by adding 10 mL of 1.0 M acetic acid. pH of this solution is adjusted to 5.0 by adding 1.0 M sodium acetate solution. It is then diluted to 100 mL with 0.05 M acetate buffer solution. This solution is stored in a refrigerator.
- Alkaline Ferricyanide Solution : 0.5 g of potassium ferricyanide ($\text{K}_3\text{Fe}(\text{CN})_6$) dissolve in 1,000 mL of 0.5 M sodium carbonate solution. This solution is sealed and stored in a brown bottle.

Storage standard of Chitosanase

Chitosanase is strongly hygroscopic, hence should be stored in a hermetic container in a cold dark place.

Chlorine

Chemical Formula: Cl₂

INS No.: 925

Molecular Weight: 70.91

CAS No.: 7782-50-5

Compositional Specifications of Chlorine

Content Chlorine should contain not less than 99.5% of chlorine (Cl₂).

Description Chlorine is pale greenish yellow and irritative gas. It liquefies under certain pressure.

Identification Chlorine is passed through 10 mL of ice-chilled sodium hydroxide solution(4.3→100). The resulting solution shows the chloride reaction of Identification.

Purity

(1) Involatiles

(A) Apparatus



-A : Hard glass container with 190 mm diameter × 100 mm depth

-B : 150 mL graduated Erlenmeyer flask

-C : adaptor

-D : ground glass tube

-E₁, E₂ : U-shaped absorbent tube with 100 mm length (Absorbent tube is washed clean and dried, which is then filled with anhydrous magnesium perchlorate up to 20 mm of the tube. The tube is plugged with cotton. Stoppers are placed to isolate the tube from atmospheric air). Before connecting to the apparatus, the U tube is connected to the chlorine gas tube and the container valve is opened so that the flow rate is 2 ~ 3 bubbles per second at the outlet. is attached. After the valve is kept open for 1 hour, dry air is passed through for exactly 5 minutes at a flow rate of 4.5 L per minute. After plugging the inlet and outlet, the tube is kept for 10 minutes at normal temperature, which is then weighed for use. Chlorine gas is passed only when the drying agent is replaced and dry air is passed prior to water content test.

-F₁, F₂ : 2 l glass capturing bottle

-G : glass drying tower with 50 mm external diameter x 480 mm length (Bottom is filled with glass wool up to 40 mm, filled with anhydrous magnesium perchlorate by 190 mm, filled with glass wool by 20 mm, filled with anhydrous magnesium perchlorate by 190 mm, and finally filled with glass wool). At the top of the tower, a flow meter is installed so that air flux can be measured.

(B) Test Method : A container (equipped with a valve to control the outlet flux) is connected to the inlet of the adapter (C). Glass container (A) is filled with dry ice and 100 mL of trichloroethylene. The adapter (C) is connected to the Erlenmeyer flask (B), which is then kept immersed in (A) so that it is completely cooled. Gas outlet tube of the adapter is connected to the capturing bottle (F₁) that is filled with 1.5 L of water. This capturing bottle (F₁) is connected to another capturing bottle (F₂), which is filled with 1.5 L of 20% sodium hydroxide solution. When the apparatus is set up, the valve of the container is slowly opened so that the gas flows in. The container is slightly tilted so that liquid chlorine flows out slowly. When liquid chlorine fills 30 ~ 50 mL in the Erlenmeyer flask (B), the valve is closed. After a while, the Erlenmeyer flask (B) is disconnected from the glass container (A). Previously weighed Erlenmeyer flask (B) transfer into a glass container (A) and adapter (C) is attached. Precisely measured 150 mL of liquid chlorine is added to the Erlenmeyer flask(B). The inlet is closed by disassembling the connection tube. Gas outlet tube of the adapter (C) is disconnected from the capturing bottle (F₁). To this gas outlet tube, U-shaped absorbent tubes (E₁, E₂), which are previously weighed for water content test, are connected serially. The capturing bottle (F₁) is again connected to the absorbent tube (E₂) and glass container (A) is separated. Liquid chlorine in the Erlenmeyer flask (B) is evaporated at room temperature. When liquid chlorine in the Erlenmeyer flask(B) evaporates, a drying tower is attached to the inlet of the adapter (C) and dry air is supplied precisely for 5 minutes at a flow rate of 4.5 L/minute. The Erlenmeyer flask (B) is separated and covered with a small watch glass. After 10 minutes, the flask is wiped clean with filter paper and weighed. The content of involatiles should not be more than 0.015%.

$$\text{Involatiles(\%)} = \frac{a - b}{V \times 1.68} \times 100$$

a : Previously known weight of Erlenmeyer flask (B) (g) + weight of involatiles (g)

b : Previously known weight of Erlenmeyer flask (B) (g)

V : Volume of sample (mL)

1.68 : Weight of 1 mL liquid chlorine at -80°C (g)

(2) Arsenic : It should be no more than 4.0 ppm tested by Arsenic Limit Test.

(3) Lead : To 10 mL of Test Solution (A) in (2) Purity, add 0.5N nitric acid to make 25 mL, test solution. When the test solution is tested by Atomic Absorption Spectrophotometry or Inductively Coupled Plasma Emission Spectroscopy, its content should not be more than 2.0 ppm.

(4) Mercury: 2 mL of Test Solution (A) is tested for mercury following the Purity (5) for Sodium Hydroxide (not more than 1 ppm).

Water Content Inlets and outlets of the U shaped absorbent tubes (E_1 , E_2), which is set up for water content test of Involatiles in Purity (1), are closed. The tubes are then wiped cleanly with filter paper. After 10 minutes, they are weighed and water content is calculated using the following equation. The water content should not be more than 0.015%.

$$\text{Water content(\%)} = \frac{(E_1 - E_1') + (E_2 - E_2')}{V \times 1.68} \times 100$$

E_1 , E_2 : The weight of absorbent tube after sample is passed through (g)

E_1' , E_2' : The weight of absorbent tube before sample is passed through (g)

V : Weight of sample (mL)

1.68 : Weight of 1 mL liquid chlorine at -80°C (g)

Assay A Bunde burette is used for apparatus as shown below. An auxiliary valve is connected to the container valve. The auxiliary valve is then connected to E. Stopcocks B and C are then opened. Chlorine gas is introduced to A by slowly opening the auxiliary valve. Air is completely replaced by passing the gas for 10 ~ 15 minutes. After closing C and B, E is separated from the auxiliary valve and set-aside until it reaches room temperature. Then the pressure of A is equilibrated with the atmosphere by slightly opening the valve C. A bottle F is filled with 10% potassium iodide and then connected to E. Small amount of solution is passed through E and D by turning the stopcock B. Then the stopcock B is turned to add small amount of potassium iodide solution to A. B is then closed and chlorine gas is absorbed by shaking the burette. After the absorption is completed by repeating this procedure, it is cooled for 10 ~ 15 minutes. Liquid in A and F are adjusted to a same level. The volume of the gas in A is obtained and the chlorine content is calculated from the following equation.

$$\text{Chlorine Content(\%)} = 100 - V$$

V : Volume of the gas left in A (mL)

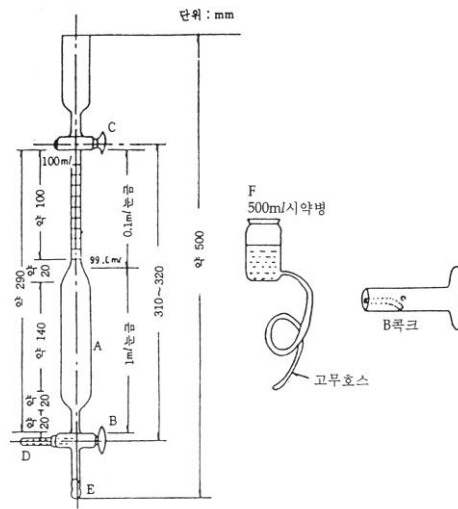

※Caution : Chlorine is very irritating gas. Care must be taken to avoid contacts with the respiratory organs and eyes. (draft room should be used for testing).

Chlorine Dioxide

Chemical Formula: ClO₂

Molecular Weight: 67.46

Synonyms: Chlorine (IV) oxide; Chlorine peroxide

INS No.: 926

CAS No.: 10049-04-4

Chlorophyll

INS No.: 140

Synonyms: Magnesium chlorophyll; Magnesium
phaeophytin

CAS No.: 1406-65-1

Definition Chlorophyll is a pigment obtained by extracting chlorella (*Chlorella pyrenoides* CHIK, etc.) of chlorella, spinach (*Spinacia oleracea* L.) of chenopodiaceae, comfrey (*Symphytum officinale* LEDEB) of boraginaceae, and Spirulina (*Spirulina platensis* NORD.), a blue-green algae (GEITLER, etc.) with ethyl alcohol or organic solvents such as acetone, isopropyl alcohol, methyl alcohol, and hexane. Its major pigment component is Chlorophylls. Dilutant, stabilizer, or solvent can be added for the purpose of color value adjustment and quality preservation.

Compositional Specifications of Chlorophyll

Content Color value ($E_{1cm}^{10\%}$) of Chlorophyll should be more than the indicated value.

Description Chlorophyll is green ~ dark green liquid or paste with a slight characteristic scent.

Identification (1) A solution of Chlorophyll in n-hexane (1→100) is green color and has maximum absorption bands near 415 nm, 425 nm and 660 nm. Weigh 1 g which is converted to 600 of color value from indicated value of Chlorophyll. It is dissolved in 100 mL of n-hexane and this solution shows green color. When mix and shake it with 0.5 mL of hydrochloric acid, the color of this solution is changed to yellow with green.

(2) Weigh 1 g which is converted to 600 of color value from indicated value of Chlorophyll. It is dissolved in 100 mL of ethanol and this solution shows a red fluorescence.

(3) A solution of Chlorophyll in n-hexane has maximum absorption bands near 410~430 nm and 660~670 nm.

(4) Weigh 1 g which is converted to 600 of color value from indicated value of Chlorophyll and dissolve in 30 mL of n-hexane. 2 μl of this solution drop-wise added on to a thin layer plate, which is prepared by using silica gel (activated by heating at 110°C for 1 hour) for thin layer chromatography. Using a mixture of n-hexane : acetone : tert-butylalcohol (10:1:1) as a developing solvent, each plate is developed up to 10 cm, and then dried in air. R_f value shows yellowish green color(chlorophyll b), green color(chlorophyll a) and gray color(feofitin) spots at near 0.3, 0.4 and 0.65. When these plates are observed under UV light (major wavelength at 366 nm) in a dark place, they show a red fluorescence. And R_f value shows yellow color(xanthophyll) and orange yellow color(β -carotene) spots at near 0.25 and 0.95. When these plates are observed under UV light (major wavelength at 366 nm) in a dark place, they don't show any fluorescence.

Purity (1) Arsenic : It should be no more than 4.0 ppm tested by Arsenic Limit Test.

- (2) Lead : When 5.0 g of Chlorophyll is tested by Atomic Absorption Spectrophotometry or Inductively Coupled Plasma Emission Spectroscopy, its content should not be more than 5.0 ppm.
- (3) Cadmium : When 5.0 g of Chlorophyll is tested by Atomic Absorption Spectrophotometry or Inductively Coupled Plasma Emission Spectroscopy, its content should not be more than 1.0 ppm.
- (4) Mercury : When Chlorophyll is tested by Mercury Limit Test, its content should not be more than 1.0ppm.

Acetone		Not more than 50ppm (individual or total if combined)
Isopropyl alcohol		
Methyl alcohol		
Hexane		

Methylene chloride Not more than 10ppm

- (5) Residual Solvents : When Chlorophyll is tested by Purity (4)(5) for Paprika Extract Pigments, the content of residual solvents should be

Assay (Color Value) Appropriate amount of Chlorophyll is precisely weighted so that the absorption is within 0.3 ~ 0.7 and dissolved in n-hexane so that the total volume is 100 mL (if it is water soluble, water is used). 5 mL of this solution is diluted to 100 mL with n-hexane (Test Solution). If necessary, the solution is centrifuged and the supernatant is used. Using n-cylohexane as a reference solution, absorption A is measured at the maximum absorption near 660 nm with 1cm path length. Color value is obtained using the following equation.

$$\text{Color Value} \left(\frac{E_{1\text{cm}}^{10\%}}{\text{g}} \right) = \frac{A \times 200}{\text{Weight of the sample(g)}}$$

Choline Bitartrate

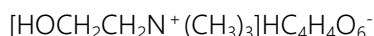

Chemical Formula: $\text{C}_9\text{H}_{19}\text{NO}_7$

Molecular Weight: 253.25

INS No.: 1001(v)

Synonyms: (2-Hydroxyethyl)trimethylammonium
bitartrate

CAS No.: 87-67-2

Compositional Specifications of Choline Bitartrate

Content Choline Bitartrate, when calculated on the dried basis(anhydrous), should contain not less than 98.0% of choline bitartrate ($\text{C}_9\text{H}_{19}\text{NO}_7$).

Description Choline Bitartrate is white hygroscopic crystalline powder with sour taste.

Identification Proceed as directed under Identification for [Choline Chloride].

Purity (1) Lead : When 5.0 g of Choline Bitartrate is tested by Atomic Absorption Spectrophotometry or Inductively Coupled Plasma Emission Spectroscopy, its content should not be more than 2 ppm.

(2) 1, 4-Dioxane : To 0.5 g of Choline Bitartrate and 0.1 g of defoamer(containing silicone), add 10 mL of water and diffuse with ultrasonic waves, test solution. Transfer this solution into 25 mL of frit sparger, hold the temperature of container at 50°C, and analyze with Purge and Trap and Gas chromatograph. Separately, to the solution, which 2.5µg of 1,4-Dioxane is contained in 10 mL of water, add 0.1 g of defoamer, standard solution. Analyze the standard solutin in the same manner as the sample. (not more than 5.0 ppm)

Operation Condition

Purge and Trap

Trap : Vorcarb 3000 or its equivalent

Purge time : 11 minutes

Desorption temperature and time : 250°C, 4 minutes

Cryo focus temperature : -150°C

Bake temperature and time : 260°C, 10 minutes

Gas chromatography

Column : HP-FFAP(60m × 0.32µm) or its equivalent

Detector : (Hydrogen) Flame Ionization Detector (FID)

Column Temperature : held at 70°C for 5 minutes and is raised to 180°C at a rate of 5°C per minute

Temperature at injection hole : 200°C

Detector Temperature : 250°C

Carrier gas and flow rate : Nitrogen, 0.9 m per minute

Water Content Choline Bitartrate is dried in a vacuum desiccator (phosphorous pentoxide) for 4 hours.

The water content should not be more than 0.1%.

Residue on Ignition When thermogravimetric analysis is done with 2 g of Choline Bitartrate, the amount of residue should not be more than 0.1%.

Assay Approximately 0.5 g of Choline Bitartrate is precisely weighed into a 250 mL Erlenmeyer flask. After adding 50 mL of glacial acetic acid, it is completely dissolved by heating in a water bath. After cooling, the solution is titrated with 0.1 N perchloric acid solution (Indicator : 2 drops of crystal violet solution in glacial acetic acid). The end point is where the color of the solution becomes green. Separately, perform a blank test in the same manner.

1 mL of 0.1 N perchloric acid solution = 25.36 mg $C_9H_{19}NO_7$

Choline Chloride

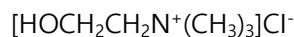

Chemical Formula: $\text{C}_5\text{H}_{14}\text{ClNO}$

Molecular Weight: 139.62

INS No.: 1001(iii)

Synonyms:

(2-Hydroxyethyl)trimethylammonium chloride

CAS No.: 67-48-1

Compositional Specifications of Choline Chloride

Content Choline Chloride, when calculated on the dried basis(anhydrous), should contain within a range of 98.0%~100.5% of choline chloride ($\text{C}_5\text{H}_{14}\text{ClNO}$).

Description Choline Chloride is colorless ~ white crystallite or crystalline powder with characteristic scent.

Identification (1) Dissolve 0.5 g of Choline Chloride in 2 mL of water, and add 3 mL of sodium hydroxide solution and heat. It generates a smell of trimethyl amine.

(2) When Dissolve 0.5 g of Choline Chloride in 2 mL of iodine solution, reddish brown precipitates are formed immediately. 5 mL of sodium hydroxide solution is added to dissolve the precipitates. Then the solution turns clear yellow. Upon heating, yellow precipitates are formed Producing a smell of iodoform.

(3) When to 1 mL of Choline Chloride solution (1→100), add 2 mL of potassium ferrocyanide solution (1→100) and 2 mL of cobalt chloride solution, it turns green immediately.

◦Cobalt Chloride Solution : 2 g of cobalt chloride (6 hydrated) is dissolved in 1mL of hydrochloric acid and sufficient water, which is diluted to 100 mL with water.

(4) Choline Chloride solution (1→20) responds to the test for Chloride in Identification.

Purity (1) Lead : When 5.0 g of Choline Chloride is tested by Atomic Absorption Spectrophotometry or Inductively Coupled Plasma Emission Spectroscopy, its content should not be more than 2.0ppm.

(2) 1,4-Dioxane : To 0.5 g of Choline Chloride and 0.1 g of defoamer(containing silicone), add 10 mL of water and diffuse with ultrasonic waves, test solution. Transfer this solution into 25 mL of frit sparger, hold the temperature of container at 50°C, and analyze with Purge and Trap and Gas chromatograph. Separately, to the solution, which 2.5µg of 1,4-Dioxane is contained in 10 mL of water, add 0.1 g of defoamer, standard solution. Analyze the standard solutin in the same manner as the sample (not more than 10 ppm).

Operation Condition

Purge and Trap

Trap : Vorcarb 3000 or its equivalent

Purge time : 11 minutes

Desorption temperature and time : 250°C, 4 minutes

Cryo focus temperature : -150°C

Bake temperature and time : 260°C, 10 minutes

Gas chromatography

Column : HP-FFAP(60m × 0.32µm) or its equivalent

Detector : (Hydrogen) Flame Ionization Detector (FID)

Column Temperature : held at 70°C for 5 minutes and is raised to 180°C at a rate of 5°C per minute

Temperature at injection hole : 200°C

Detector Temperature : 250°C

Carrier gas and flow rate : Nitrogen, 0.9 m per minute

Water Content Water content of Choline Chloride is determined by water determination (Karl-Fisher Method) and should not be more than 0.5%.

Residue on Ignition When thermogravimetric analysis is done with 4 g of Choline Chloride, the amount of residue should not be more than 0.05%.

Assay Approximately 0.3 g of Choline Chloride is precisely weighed and transferred into a 250 mL Erlenmeyer flask. 50 mL of glacial acetic acid is added to the flask, which is then heated in a water bath until the solid dissolves completely. After cooling, 10 mL of mercury acetate for nonaqueous titration and 2 drops of crystal violet glacial acetic acid solution are added to the solution, which is then titrated with 0.1 N perchloric acid solution. At the end point, the solution turns green. Separately, a blank test is carried out by the same procedure.

1 mL of 0.1 N perchloric acid solution = 13.96 mg C₅H₁₄ClNO

Chromic chloride

Chemical Formula: $\text{CrCl}_3 \cdot 6\text{H}_2\text{O}$

Molecular Weight: 266.45

Synonyms: Chromium(III) chloride

CAS No.: 10025-73-7

Compositional Specifications of Chromic chloride

Content Chromic chloride should contain within a range of 98.0 ~ 101.0% of Chromic chloride($\text{CrCl}_3 \cdot 6\text{H}_2\text{O}$).

Description Chromic chloride is purple or green crystalline solid.

Identification (1) To 5mL of the aqueous solution of chromic chloride (1→250), 1mL of 5N sodium hydroxide and 10 drops of 30% hydrogen peroxide are added, gently heated for about 2 minutes, yellow color develops.

(2) To 5 mL of the aqueous solution of chromic chloride (1→250), 5 drops of silver nitrate solution are added, then white precipitate is generated, which is not soluble to nitric acid.

Purity (1) Water-insoluble substances : 10 g of chromic chloride is precisely weighed, 100 mL of water is added, the solution is resolved in a water bath for 30 minutes, and the insoluble substances are filtered through a glass filter (IG4), The solution in a beaker, which is washed by hot water, is filtered through a glass filter, and the residue is washed until the color of the solution washed lastly. When the glass filter is dried for 2 hours at 105° , its content should not be more than 1 mg. (not more than 0.01%)

(2) Ammonium hydroxide soluble substances : 2 g of chromic chloride is added to 80 mL of water, heated, and 10 mL of ammonia water is added. It is occasionally shaken while warming up in a water bath for 30 minutes, cooled, water is added to 100 mL, mixed, and filtered. To 50 mL of filtrate, 0.5 mL of sulfuric acid is added, and evaporated to dryness in a water bath. It is then heat-treated until the weight becomes constant, the residue should not be more than 2 mg (not more than 0.20% as SO_4^{2-}).

(3) Sulfate : To 10 mL of chromic chloride solution (2→10), 1 mL of 3N hydrochloric acid is added, filtered, the filter paper is washed twice with 5 mL of water, and diluted with water to 40 mL, test solution. Separately, 1 g of chromic chloride is dissolved in 10 mL of water, filtered, and 0.1mL of 0.02N sulfuric acid is added, reference solution. To both solutions, 3 mL of barium chloride(12→100)is added, mixed well, and set aside whole night at the room temperature. When supernatant liquid is discarded, the solution, which is more than 2 times of test solution, is remained in reference solution. Both solutions are diluted with water to 25 mL, processed under ultrasonic waves, then the turbidity of test solution should not be more than that of reference solution (not more than 0.01%).

(4) Iron : 1 g of chromic chloride is added to 100 mL of water, dissolved, 10 mL of the solution is added to water to make 45 mL, and 2 mL of hydrochloric acid is added and mixed, test solution. 15 mL each of butyl alcohol is added to test solution and iron standard solution, and 15 mL of ammonium thiocyanate(30→100) are added, and mixed well. When the layer is separated, the color of the supernatant should not be deeper than the color of standard solution (not more than 0.01%).

Assay 0.4 g of chromic chloride is precisely weighed, dissolved in 100 mL of water, 5 mL of 5N sodium hydroxide is added and mixed. 4 mL of 30% hydrogen peroxide is slowly added, boiled for 5 minutes, slightly cooled, and 5 mL of sulfuric acid nickel solution(1→20) is added. It is boiled and cooled until oxygen is not generated, and 2N sulfuric acid is added until the color of the solution changes from yellow to orange. To this solution, 4 g of potassium iodide and 2 g of sodium hydrogen carbonate are dissolved in 100 mL of water and added. Then 6 mL of hydrochloric acid is added and mixed. Place the stopper on the flask, set it aside in a dark place for 10 minutes, and titrate the liberated iodine with 0.1N sodium thiosulfate (indicator : starch solution).

1 mL of 0.1N sodium thiosulfate = 8.882mg $\text{CrCl}_3 \cdot 6\text{H}_2\text{O}$

Cinnamaldehyde



Chemical Formula: C₉H₈O

Molecular Weight: 132.16

Synonyms: Cinnamic aldehyde

CAS No.: 104-55-2

Compositional Specifications of Cinnamaldehyde

Content Cinnamaldehyde should contain not less than 98.0% of cinnamaldehyde (C₉H₈O).

Description Cinnamaldehyde is a colorless to light yellow transparent liquid having a cinnamon-like odor.

Identification (1) When 1 drop of fluoroglucyn hydrochloric acid solution is added to 5 drops of Cinnamaldehyde, the solution turns red and precipitates are formed.

(2) When 4 drops of nitric acid are added to 4 drops of Cinnamaldehyde and cooled to 5°C or lower, white ~ pale yellow crystallites are formed.

Purity (1) Specific Gravity : Specific gravity of Cinnamaldehyde should be within a range of 1.051 ~ 1.056

(2) Refractive Index : Refractive Index n_D^{20} of Cinnamaldehyde should be within a range of 1.619 ~ 1.625

(3) Clarity and Color of Solution : When Cinnamaldehyde 1 mL is dissolved in 5 mL of 60% ethanol, the solution should be clear.

(4) Chlorinated Compounds : When Cinnamaldehyde is tested by Copper Mesh Test Method in Test Methods for Flavorings, it should be appropriate.

(5) Acid Value : Acid value of Cinnamaldehyde is tested by Acid Value in Flavoring Substance Test. It should not be more than 5.

Assay Approximately 1 g of Cinnamaldehyde is accurately weighed and tested by Method 1 under aldehydes and ketons content in Flavoring Substances Test. In this case, the mixture is set-aside for 15 minutes.

1 mL of 0.5 N alcoholic solution of potassium hydroxide = 66.08 mg C₉H₈O

Cinnamic Acid



Chemical Formula: $C_9H_8O_2$

Molecular Weight: 148.16

Synonyms: 3-Phenylacrylic acid

CAS No.: 621-82-9

Compositional Specifications of Cinnamic Acid

Content Cinnamic Acid, when calculated on the dried basis, should contain not less than 99.0% of cinnamic acid ($C_9H_8O_2$).

Description Cinnamic Acid occurs as a white crystalline powder having a characteristic odor.

Identification (1) To 0.5 g of Cinnamic Acid, add 1 mL of sulfuric acid, and dissolve while heating in a water bath. The color of the solution changes to a yellow-green color. Continue heating. The color changes to a dark red color.

(2) Dissolve 0.1 g of Cinnamic Acid in 2 mL of potassium hydroxide solution, add 5 mL of potassium permanganate solution, and warm in hot water. An odor of benzaldehyde is evolved.

Purity (1) Melting Point : Melting point of Cinnamic Acid should be within a range of 132 ~ 135°C

(2) Clarity and Color of Solution : When 1 g of Cinnamic Acid is dissolved in 7 mL of ethanol, the solution should be clear.

(3) Characteristics of Alkali Solution : When 0.2 g of Cinnamic Acid is dissolved in 2 mL of sodium carbonate solution and 8 mL of water, the solution should be clear.

(4) Chloride : When Cinnamic Acid is tested by Copper Mesh Test Method in Test Methods for Flavorings, it should be appropriate.

(5) Arsenic : It should be no more than 4.0 ppm tested by Arsenic Limit Test.

(6) Lead : When 5.0 g of Cinnamic Acid is tested by Atomic Absorption Spectrophotometry or Inductively Coupled Plasma Emission Spectroscopy, its content should not be more than 2.0 ppm.

Loss on Drying When Cinnamic Acid is dried for 4 hours in a vacuum desiccator (silica gel), the weight loss should not be more than 1%.

Residue on Ignition When thermogravimetric analysis is done with Cinnamic Acid, the residue should not be more than 0.05%.

Assay Dissolve about 0.2 g of Cinnamic Acid, previously dried and accurately weighed, in 10 mL of

neutralized alcohol and 10 mL of water and titrate with 0.1 N sodium hydroxide solution.(indicator : 3 drops of phenolphthalein solution).

1mL of 0.1 N sodium hydroxide solution = 14.816 mg $C_9H_8O_2$

Cinnamyl Acetate



Chemical Formula: $C_{11}H_{12}O_2$

Molecular Weight: 176.22

CAS No.: 103-54-8

Compositional Specifications of Cinnamyl Acetate

Content Cinnamyl Acetate should contain not less than 98.0% of cinnamyl acetate ($C_{12}H_{12}O_2$).

Description Cinnamyl Acetate is a colorless or slightly yellowish, transparent liquid having a characteristic odor.

Identification To 1 mL of Cinnamyl Acetate, add 5 mL of 10% alcoholic solution of potassium hydroxide. Equip with a reflux condenser, and heat in a water bath for 30 minutes. The characteristic odor disappears. Cool, and add 5 mL of water and 1.2 mL of diluted hydrochloric acid. The solution responds to the test for Acetate (C) in Identification.

Purity (1) Specific Gravity : Specific gravity of Cinnamyl Acetate should be within a range of 1.047 ~ 1.051.

(2) Refractive Index : Refractive Index n_D^{20} of Cinnamyl Acetate should be within a range of 1.539 ~ 1.543.

(3) Clarity and Color of Solution : When 1 mL of Cinnamyl Acetate is dissolved in 5 mL of 70% alcohol, the solution should be clear.

(4) Acid Value : Acid value of Cinnamyl Acetate is tested by Acid Value in Flavoring Substance Test. The content should not be more than 3.

Assay Accurately weigh about 1 g of Cinnamyl Acetate, and proceed as directed under Ester Content in Flavoring Substances Tests.

1 mL of 0.5 N alcoholic solution of potassium hydroxide = 88.11 mg of $C_{12}H_{12}O_2$

Cinnamyl Alcohol



Chemical Formula: $C_9H_{10}O$

Molecular Weight: 134.14

Synonyms: Cinnamic alcohol

CAS No.: 104-54-1

Compositional Specifications of Cinnamyl Alcohol

Content Cinnamyl Alcohol should contain not less than 98.0% of cinnamyl alcohol ($C_9H_{10}O$).

Description Cinnamyl Alcohol is a colorless to light yellow liquid or occurs as white to light yellow crystalline lumps, having a characteristic odor.

Identification To 3 drops or 0.2 g of Cinnamyl Alcohol, add 5 mL of potassium permanganate solution (1→20) and 1 mL of diluted sulfuric acid. An odor of cinnamaldehyde is evolved.

Purity (1) Solidification Temperature : Solidification temperature should not be less than 31°C.

(2) Clarity and Color of Solution : When 1 g of Cinnamyl Alcohol is dissolved in 1 mL of 70% ethanol by heating at 35°C, the solution should be clear.

(3) Acid Value : Acid value of Cinnamyl Alcohol is tested by Acid Value in Flavoring Substance Test. It should not be more than 1.

(4) Cinnamaldehyde : Approximately 5 g of Cinnamyl Alcohol is accurately added and tested by the Method 2 of Hydroxylamine Method in Content Measurement Methods for Aldehydes and Ketones. The content should not be more than 1.5%. In the procedure, the mixture is set-aside for 15 minutes.

Residue on Ignition When thermogravimetric analysis is done with Cinnamyl Alcohol, the residue should not be more than 0.03%.

Assay Approximately 0.5 g of Cinnamyl Alcohol is accurately weighed and tested by Alcohol Content Measurement Method 2 in Flavoring Substances Test.

1 mL of 0.5 N alcoholic solution of potassium hydroxide = 67.09 mg $C_9H_{10}O$

Citral



Chemical Formula: $C_{10}H_{16}O$

Molecular Weight: 152.24

Synonyms: Lemarome

CAS No.: 5392-40-5

Compositional Specifications of Citral

Content Citral should contain not less than 96.0% of citral ($C_{10}H_{16}O$).

Description Citral is a colorless to light yellow liquid having a lemon-like odor.

Identification To 1 mL of Citral, add 2 mL of sodium hydrogen sulfite solution and 2 drops of sodium carbonate solution, and shake. The mixture evolves heat and forms white crystalline lumps. Add 10 mL of sodium hydrogen sulfite solution, and heat in a water bath while shaking. The crystalline lumps dissolve, and the lemon-like odor disappears.

Purity (1) Specific Gravity : Specific gravity should be within a range of 0.885 ~ 0.891

(2) Refractive Index : Refractive Index n_D^{20} should be within a range of 1.486 ~ 1.490

(3) Clarity and Color of Solution : When 1 mL of Citral is dissolved in 10 mL of 60% alcohol, the solution should be clear.

(4) Acid Value : Acid value of Citral is tested by Acid Value in Flavoring Substance Test. It should not be more than 5.

Assay Accurately weigh about 1 g of Citral, and proceed as directed under Method 2 of Aldehyde and Ketone Content in Flavoring Substances Tests. In the procedure, allow the mixture to stand for 15 minutes.

1 mL of 0.5 N Hydrochloric acid = 76.12 mg of $C_{10}H_{16}O$

Citric Acid

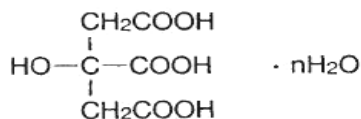

Chemical Formula: C₆H₈O₇

Molecular Weight: 192.13

INS No.: 330

CAS No.:

Synonyms: 2-Hydroxy-1,2,3-propane-tricarboxylic acid

77-92-9(anhydrous)

5949-29-1(1 hydrate)

Definition Citric Acid occurs as crystals (mono hydrated) called citric acid (crystal) or as anhydrous material called citric acid (anhydrous).

Compositional Specifications of Citric Acid

Content Citric Acid, when calculated on the anhydrous of dried basis, should contain not less than 99.5% of citric acid (C₆H₈O₇=192.13).

Description Citric Acid occurs as colorless, transparent crystals. granules. or lumps, or as a white powder. It is odorless and has a strong acid taste.

Identification (1) Citric Acid solution (1→10) is acidic.

(2) Citric Acid responds to the test for Citrate Salt in Identification.

Purity (1) Sulfate : When 0.5 g of Citric Acid is tested by Sulfate Limit Test, its content should not be more than the amount that corresponds to 0.5 mL of 0.01 N sulfuric acid.

(2) Oxalate : When 1 g of Citric Acid is dissolved in 10 mL of water, and added 2 mL of calcium chloride solution, it should not be turn turbid.

(3) Arsenic : It should be no more than 1.3 ppm tested by Arsenic Limit Test.

(4) Lead : When 5.0 g of Citric Acid is tested by Atomic Absorption Spectrophotometry or Inductively Coupled Plasma Emission Spectroscopy, its content should not be more than 0.5 ppm.

(5) Mercury : When citric acid is tested by Mercury Limit Test, its content should not be more than 1.0 ppm.

(6) Calcium : 1 g of Citric Acid is dissolved in 10 mL of water, which is neutralized with ammonia solution. Then, 1 mL of ammonium oxalate solution is added, it should not be turn turbid.

(7) Readily Carbonizable Substances : When 0.5 g of Citric Acid is dissolved in 5 mL of sulfuric acid by heating at about 90°C for 1 hour, the color of the solution should not be deeper than that of the color standard solution K.

(8) Polynuclear Aromatic Hydrocarbon : 25 g of Citric Acid is dissolved in 30 mL of water by heating at approximately 50°C. After cooling, the solution is extracted 3 times with 20 mL each of n-hexane (UV

absorption spectrophotometry grade). It is centrifuged at 2,500 ~ 3,000 rpm for approximately 10 minutes and concentrated to 1 ~ 2 mL by evaporating n-hexane out. After cooling, n-hexane (UV absorption spectrophotometry grade) is added to the concentrate to bring the total volume to 10 mL, Test Solution. Absorption of test solution is measured at 260 ~ 350 nm with 1 cm path length. The difference in absorbance (compared to reference solution) should not be more than 0.05 in this range. In this case, use the reference solution obtained by following method. To 30 mL of water, extract 20 mL of n-hexane (UV absorption spectrophotometry grade) 3 times repeatedly, and follow the same procedure as test solution.

(9) Isocitric Acid : 0.5 g of Citric Acid is heated at 105°C for 3 hours and cooled, which is dissolved in 10 mL of acetone, Test Solution. Using 0.005 mL of the test solution, it is tested by the Method 1 in Paper Chromatography. Only one spot should be observed. For the filter paper, a No.2 filter paper for chromatography is used. When the developing solvent front reaches approximately 25 cm, and stop developing and dry in air. Bromophenol blue solution is sprayed upon the paper. A reference solution is not used for this test. N-butyl alcohol, formic acid, and water (8:3:2) are mixed and set-aside. The supernatant of solution is used as a developing solvent.

Residue on Ignition When thermogravimetric analysis is done with 2 g of citric acid, the residue should not be more than 0.05%.

Water Content Water Content of Citric Acid is tested by the direct titration method in water content determination (Karl-Fischer Method). The water content should not be more than 0.5% for citric acid (anhydrous) and 8.8% for citric acid (crystal)

Assay Accurately weigh about 1.5 g of Citric Acid is dissolved in water and make to 250 mL, and 25 mL of which is then titrated with 0.1 N sodium hydroxide solution (indicator : 2 ~ 3 drops of phenolphthalein solution).

$$1 \text{ mL of } 0.1 \text{ N sodium hydroxide} = 6.404 \text{ mg } \text{C}_6\text{H}_8\text{O}_7$$

Citronellal



Chemical Formula: $C_{10}H_{18}O$

Molecular Weight: 154.25

Synonyms: 3,7-Dimethyl-6-octenal; Rhodinal

CAS No.: 106-23-0

Compositional Specifications of Citronellal

Content Citronellal should contain not less than 85.0% of citronellal ($C_{10}H_{18}O$).

Description Citronellal is a colorless, transparent liquid having a characteristic odor.

Identification To 1 mL of Citronellal, add 2 mL of sodium hydrogen sulfite solution and 2 drops of anhydrous sodium carbonate solution, and shake. The mixture evolves heat and forms white crystalline lumps. Add 10 mL of sodium hydrogen sulfite solution, and heat in a water bath while shaking. The crystalline lumps dissolve.

Purity (1) Specific Gravity : Specific gravity should be within a range of 0.850 ~ 0.860.

(2) Refractive Index : Refractive Index n_D^{20} should be within a range of 1.446 ~ 1.456.

(3) Clarity and Color of Solution : When 1 mL of Citronellal is dissolved in 5 mL of 70% alcohol, the solution should be clear.

(4) Acid Value : Acid value of Citronellal is tested by Acid Value in Flavoring Substance Test. It should not be more than 3.

Assay Accurately weigh about 1.1 g of Citronellal, and proceed as directed under Method 2 in Aldehyde and Ketone Content in Flavoring Substances Tests. In the procedure allow the mixture to stand for 1 hour.

1 mL of 0.5 N hydrochloric acid = 77.13 mg of $C_{10}H_{18}O$

Citronellol



Chemical Formula: $C_{10}H_{20}O$

Molecular Weight: 156.27

Synonyms: 3,7-Dimethyl-6-octen-1-ol

CAS No.: 106-22-9

Compositional Specifications of Citronellol

Content Citronellol should contain not less than 90.0% of citronellol ($C_{10}H_{20}O$).

Description Citronellol is a colorless, transparent liquid having a characteristic odor.

Identification To 1 mL of Citronellol, add 1 mL of anhydrous acetic acid and 1 drop of phosphoric acid, keep the solution at a lukewarm temperature for 10 minutes, add 1 mL of water, shake in warm water for 5 minutes, cool, and add sodium carbonate solution to make slightly alkaline. A characteristic odor is evolved.

Purity (1) Specific Gravity : Specific gravity should be within a range of 0.850 ~ 0.860.

(2) Refractive Index : Refractive Index n_D^{20} should be within a range of 1.454 ~ 1.462.

(3) Clarity and Color of Solution : When 2 mL of Citronellol is dissolved in 4 mL of 70% alcohol, the solution should be clear.

(4) Acid Value : Acid value of Citronellol is tested by Acid Value in Flavoring Substance Test. It should not be more than 1.

(5) Ester Value : Ester value about 5 g of Citronellol, accurately weighed, is tested by Ester Value in Flavoring Substance Test. It should not be more than 1.

(6) Aldehyde : Approximately 5 g of Citronellol is precisely weighed and tested by Hydroxylamine Method 2 of Aldehyde and Ketone Content Measurement in Flavoring Test. The volume of consumed 0.5 N hydrochloric acid should not be more than 1.3 mL.

Assay Proceed as directed under Method 1 in Alcohol Content in Flavoring Substances Tests, using about 1 g of acetylated oil.

Citronellyl Acetate

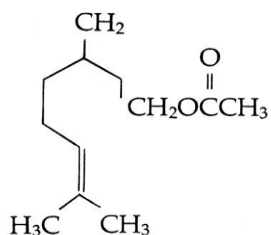

Chemical Formula: C₁₂H₂₂O₂

Molecular Weight: 198.30

CAS No.: 150-84-5

Compositional Specifications of Citronellyl Acetate

Content Citronellyl Acetate should contain not less than 92.0% of Citronellyl acetate (C₁₂H₂₂O₂).

Description Citronellyl Acetate is a colorless, transparent liquid having a characteristic odor.

Identification To 1 mL of Citronellyl Acetate, add 5 mL of 10% alcoholic solution of potassium hydroxide solution, and heat in a water bath for 10 minutes. The characteristic odor disappears, and an odor of citronellol is evolved. Cool, and add 2 mL of water and 2 mL of diluted hydrochloric acid. The solution responds to the test for Acetate (C) in Identification.

Purity (1) Specific Gravity : Specific gravity of Citronellyl Acetate should be within a range of 0.883 ~ 0.893.

(2) Refractive Index : Refractive Index n_D^{20} of Citronellyl Acetate should be within a range of 1.440 ~ 1.450.

(3) Clarity and Color of Solution : When 1 mL of Citronellyl Acetate is dissolved in 9 mL of 70% alcohol, the solution should be clear.

(4) Acid value : Acid value of Citronellyl Acetate is tested by Acid Value in Flavoring Substance Test. The content should not be more than 1.

Assay Accurately weigh about 1.4 g of Citronellyl Acetate, and proceed as directed under Ester Value and Ester Content in Flavoring Substances Tests.

1 mL of 0.5 N alcoholic solution of potassium hydroxide = 99.15 mg of C₁₂H₂₂O₂

Citronellyl Formate



Chemical Formula: $C_{11}H_{20}O_2$

Molecular Weight: 184.28

Synonyms:

3,7-dimethyl-6-octen-1-yl-methanoate

CAS No.: 105-85-1

Compositional Specifications of Citronellyl Formate

Content Citronellyl Formate should contain not less than 86.0% of citronellyl formate ($C_{11}H_{20}O_2$)

Description Citronellyl Formate is a colorless, transparent liquid having a characteristic odor.

Identification (1) To 1 mL of Citronellyl Formate, add 10 mL of 10% alcoholic solution of potassium hydroxide, and heat in a water bath for 5 minutes while shaking. The characteristic odor disappears, and an odor of citronellyl is evolved.

(2) Proceed as directed under Identification (2) in Geranyl Formate.

Purity (1) Specific Gravity : Specific gravity of Geranyl Formate should be within a range of 0.890 ~ 0.903

(2) Refractive Index : Refractive Index n_D^{20} of Geranyl Formate should be within a range of 1.443 ~ 1.449

(3) Clarity and Color of Solution : When 1 mL of the solution is dissolved in 3 mL of 80% ethanol, the solution should be clear.

(4) Acid Value : Acid value of Citronellyl Formate is tested by Acid Value in Flavoring Substance Test. It should not be more than 3. In this case, titrate while cooling in ice water until a light pink color persists for 10 seconds.

Assay Accurately weigh about 1 g of Citronellyl Formate and test Saponification Value by saponification value measuring method in Flavoring Substances Tests and Acid Value by Purity (4). Calculate the content by the following formula.

$$\text{Content (\%)} = \frac{\text{Saponification value} - \text{Acid value}}{561.1} \times 184.28$$

Cochineal Extract

INS No.: 120

CAS No.: 1343-78-8

Definition Dried bodies of *Dactylopius coccus costa* (*Coccus cacti*. Linnaeus), which is female *coccus cati* parasitic on cactus (*Nopalea coccinellifera*), is extracted with aqueous alcohol. Cochineal Extract is the concentrated solution obtained after removing the alcohol from an aqueous, aqueous alcoholic or alcoholic extract of cochineal. The major pigment component is carminic acid. Dilutant, stabilizer, or solvent can be added for the purpose of content adjustment and quality preservation.

Compositional Specifications of Cochineal Extract

Content Cochineal Extract should contain not less than 1.8% of carminic acid ($C_{22}H_{20}O_{13}$ = 492.39).

Description Cochineal Extract is red ~ dark reddish brown liquid, lump, powder, or paste having a slight characteristic odor.

Identification (1) Test Solution obtained in Content section shows a absorption maximum at about 495 nm.

(2) 1 g of Cochineal Extract is mixed with 50 mL of 0.1 N hydrochloric acid, which is filtered, if necessary. The filtrate is orange red in color. When it is alkalinized with sodium hydroxide solution, it produced violet ~ red.

Purity (1) Arsenic : It should be no more than 1.3 ppm tested by Arsenic Limit Test.

(2) Lead : When 5.0 g of Cochineal Extract is tested by Atomic Absorption Spectrophotometry or Inductively Coupled Plasma Emission Spectroscopy, its content should not be more than 2.0 ppm.

(3) Cadmium : When 5.0 g of Cochineal Extract is tested by Atomic Absorption Spectrophotometry or Inductively Coupled Plasma Emission Spectroscopy, its content should not be more than 1.0 ppm.

(4) Mercury : When 0.1 g of Cochineal Extract is tested by Mercury Test Method, its content should not be more than 1.0ppm.

(5) Protein : When 3 g of Cochineal Extract is precisely weighed, proceed as directed under Kjeldahl Method in Nitrogen Determination, multiply the content of nitrogen obtained from the test by nitrogen factor 6.25 to measure the content of protein, the amount should not be more than 2.2%.

(6) Methyl Alcohol : When Cochineal Extract is tested by Purity (5) for Paprika Extract Pigments, the content should not be more than 150ppm.

(7) Salmonella : Cochineal Extract is tested by Microbe Test Methods for Salmonella in General Test Methods, Food Code. It should be negative (-).

Assay About 800 mg of Cochineal Extract is precisely weighed and added with mixture of 2N hydrochloric acid and water(97:3), and made to volume 1,000 mL, Test Solution. Absorbance (A) of the Test Solution is measured using a mixture(97:3) of water and 2 N hydrochloric acid as the blank with 1cm cell at a

maximum absorption about 495 nm. The content (%) is calculated using the following equation. The amount of sample is adjusted so that the absorbance of the Test Solution is within the range 0.2 to 0.25.

$$\text{Content(\%)} = \frac{15A}{\text{weight of the sample(mg)}} \times \frac{100}{0.262}$$

(0.262 : absorbance of carminic acid solution (15 mg/l))

Copper Chlorophyll

Synonyms: Copper phaeophytin; CI natural green 3

INS No.: 141(i)

Compositional Specifications of Copper Chlorophyll

Description Copper Chlorophyll occurs as blue-black to green-black powder, flakes, lumps, or viscous substances, having a characteristic odor.

Identification (1) Proceed as directed under (B) of Identification (1) in Sodium 「Copper Chlorophyllin」.
(2) Dissolve 10 mg of Copper Chlorophyll in 50 mL of ether, add 2 mL of a solution of sodium hydroxide in methanol (1→100), and shake. Equip with a reflux condenser, and heat on a water bath for 30 minutes. Cool, perform extraction 35 times with 10 mL of water each time, combine the extracts, add phosphate buffer (pH 7.5) to make 200 mL, and measure the absorbance of this solution. The solution exhibits absorption maxima at wavelengths of 403 ~ 407 nm and 630 ~ 640 nm. Taking the absorbances at the absorption maxima as A_1 and A_2 , respectively, A_1/A_2 should not be more than 4.01.

Purity (1) Specific Absorbance : Accurately weigh about 0.1 g of Copper Chlorophyll, dissolve in 50 mL of ether, add 10 mL of a solution of sodium hydroxide in methanol (2→100), and shake. Equip with a reflux condenser, and heat on a water bath for 30 minutes. Cool, perform extraction four times with 20 mL of water each time, combine the extracts, and add water to make exactly 100 mL. Filter this solution, measure exactly 5.0 mL of the filtrate, add phosphate buffer (pH 7.5) to make exactly 100 mL. Quickly measure absorbance. When the absorbance at the maximum absorption band near 405 nm and its value is converted into that of a dried form, $E_{1cm}^{1\%} = 62.0$ or higher. For this procedure avoid direct sunlight, and use a light-resistant container.

(2) Inorganic Copper Salt : Weigh 1 g of Copper Chlorophyll, and dissolve in 60 mL of acetone. Procedure Proceed as directed under Purity (8) in 「Sodium Copper Chlorophyll」(Not more than 300 µg/g as Cu).

(3) Arsenic : It should be no more than 4.0 ppm tested by Arsenic Limit Test.

(4) Lead : When 5.0 g of Copper Chlorophyll is tested by Atomic Absorption Spectrophotometry or Inductively Coupled Plasma Emission Spectroscopy, its content should not be more than 5.0 ppm.

(5) Cadmium : When 5.0 g of Copper Chlorophyll is tested by Atomic Absorption Spectrophotometry or Inductively Coupled Plasma Emission Spectroscopy, its content should not be more than 1.0 ppm.

(6) Mercury : When Copper Chlorophyll is tested by Mercury Limit Test, its content should not be more than 1.0 ppm.

(8) Residual Solvent : When Copper Chlorophyll is tested by Purity (5) for 「Paprika Extract Pigments」,

Acetone

Methyl alcohol

Not more than 50 ppm(individual or total if combined)

Ethyl alcohol

Isopropyl alcohol

Hexane

Methylene Chloride Not more than 10 ppm

(8) Chlorophyllin Salt : Weigh 1 g of Copper Chlorophyll, dissolve in 30 mL of ether, add 20 mL of water, and shake. After standing, filter the water layer through a filter paper moistened with water. The filtrate should be colorless.

Loss on Drying When Copper Chlorophyll is dried for 2 hours at 105°C, the weight loss should not be more than 3%.

Copper Gluconate

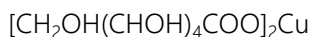

Chemical Formula: $\text{C}_{12}\text{H}_{22}\text{CuO}_{14}$

Molecular Weight: 453.84

CAS No.: 527-09-3

Compositional Specifications of Copper Gluconate

Content Copper Gluconate should contain within a range of 98.0 ~ 102.0% of copper gluconate ($\text{C}_{12}\text{H}_{22}\text{CuO}_{14}$).

Description Copper Gluconate occurs as a light blue powder.

Identification (1) Copper Gluconate solution (1→20) responds to the test for Cupric Salts in Identification.
(2) Proceed as directed under Identification (2) for 「Sodium Gluconate」.

Purity (1) Lead : When 5.0 g of Copper Gluconate is tested by Atomic Absorption Spectrophotometry or Inductively Coupled Plasma Emission Spectroscopy, its content should not be more than 5.0 ppm.
(2) Arsenic : It should be no more than 4.0 ppm tested by Arsenic Limit Test.
(3) Reducing Materials : Approximately 1 g of Sodium Gluconate is weighed and transferred into a 250 mL Erlenmeyer flask. 10 mL of water is added to dissolve the solid and 25 mL of alkaline copper citrate solution. A small beaker is placed on top of the flask, which is gently heated for precisely 5 minutes. It is then rapidly cooled to room temperature. To this solution, 25 mL of diluted acetic acid (1→10), 10 mL of 0.1 N iodine solution, 10 mL of dilute hydrochloric acid, and 3 mL of starch solution are added. The resulting solution is titrated with 0.1N sodium thiosulfate solution until the blue color disappears. The content of reduced materials should not be more than 1.0%.

$$\text{Content of reducing matter (as glucose)}(\%) = \frac{(V_1N_1 - V_2N_2) \times 27}{\text{weight of the sample}(\text{mg})} \times 100$$

V_1 : Consumed amount of 0.1 N iodine solution (mL)

N_1 : Normality of 0.1 N iodine solution

V_2 : Consumed amount of 0.1 N sodium thiosulfate solution (mL)

N_2 : Normality of 0.1 N sodium thiosulfate solution

27 : Experimental corresponding amount for D-glucose

Assay Accurately weigh about 1.5 g of Copper Gluconate, transfer into a 250 mL Erlenmeyer flask, dissolve in 100 mL of water, add 2 mL of acetic acid and 5 g of potassium iodide, shake well. Titrate this solution with 0.1 N sodium thiosulfate until the color of the solution becomes to a yellow color,

dissolve 2 g of ammonium thiocyanate, and titrate again until the color of the solution becomes to an opaque color. (Indicator : Starch solution)

1 mL of 0.1 N sodium thiosulfate = 45.38 mg of $C_{12}H_{22}CuO_{14}$

Cross-Linked Sodium Carboxymethyl Cellulose

INS: 468

Synonyms: Croscarmellose sodium; Cross- linked cellulose gum; Cross-linked sodium CMC

CAS No.: 74811-65-7

Compositional Specifications of Cross-Linked Sodium Carboxymethyl Cellulose

Description Cross-Linked Sodium Carboxymethyl Cellulose is a slightly hygroscopic, white to greyish-white, odourless powder.

Identification (1) Cross-Linked Sodium Carboxymethyl Cellulose is practically insoluble in acetone, in ethanol and in toluene.

(2) Add 1g of Cross-Linked Sodium Carboxymethyl Cellulose to 50 mL water and stir well to make a suspension. To 1mL of this suspension, add 1mL of water and 5 drops of freshly prepared solution of 1-naphthol in methanol(1→25) and gently add 2mL of sulfuric acid along a wall of the test tube. A red-purple colour develops at the interface.

(3) Add 1g of Cross-Linked Sodium Carboxymethyl Cellulose to 100mL of a solution of methylene blue(1→250,000), stir well and allow to stand. Blue cotton-like precipitates appear.

(4) The residue obtained from igniting 1 g of Sodium Carboxymethyl Cellulose at the temperature of 550-600°C for 3 hours responds to the test for Sodium salt.

Purity (1) pH : Add 1g of Cross-Linked Sodium Carboxymethyl Cellulose to 100mL water, and stir for 5 minutes. The pH of the supernatant liquid is between 5.0 and 7.0.

(2) Water-soluble substances : Weigh accurately 10g of Cross-Linked Sodium Carboxymethyl Cellulose, disperse in 800mL of water by stirring for 1 minute every 10 minutes during 30 minutes, and to allow to stand for 1 hour and centrifuge (if necessary). Filter by suction the solution and collect about 150mL of the filtrate. Heat to concentrate 100mL of this liquid avoiding to dryness, then dry the residue at 100-150°C. Weigh the mass of the residue accurately. Calculate the amount of the water soluble substance by the following formula. The amount should be not more than 10%.

$$\% \text{ water soluble substances (\%)} = \frac{M \times 800}{W}$$

M : Weight of the residue(g)

W : Weight of the sample(g)

(3) Degree of substitution : Weigh accurately 1g of Cross-Linked Sodium Carboxymethyl Cellulose, put

in a 500mL glass-stoppered conical flask and add 300mL of sodium chloride test solution. Add 25mL of 0.1M sodium hydroxide solution into the flask, stopper flask, and allow to stand for 5minute shaking occasionally. Add 5drops of m-cresol purple test solution, then add exactly 15mL of 0.1M hydrochloric acid using a buret, stopper the flask, and shake. If the color of the solution is purple, add 1mL portions of 0.1M hydrochloric acid using the buret until the solution becomes yellow, shaking after each addition. Titrate with 0.1M sodium hydroxide solution until the color changes from yellow to purple. Perform a blank determination in the same manner. Calculate the content of carboxymethyl groups(Sum of the degrees of substitution of acid-carboxymethyl group(A) and sodium-carboxymethyl group(S)) per anhydroglucose unit using the formula, the content on the dried basis should not less than 0.2 and not more than 1.5.

$$A = \frac{1150M}{7102 - 412M - 80C}$$

$$S = \frac{(162 + 58A)C}{7102 - 80C}$$

M : Amount(mmol)of sodium hydroxide required for neutralisation of 1g of sample, calculated on the dried basis

C : The value(%) obtained in Residue on ignition

m-cresol purple test solution : Dissolve 0.1g of m-cresol purple in minimum volume of alcohol and dilute to 100mL with water.

(4) Sodium chloride and Sodium glycolate : Sum of sodium chloride and sodium glycolate is not more than 0.5%, calculated on the dried basis.

(i) Sodium chloride : Weigh accurately 5g of Cross-Linked Sodium Carboxymethyl Cellulose, add 50mL of water and 5mL of 30% hydrogen peroxide, and heat on a water bath for 20 minutes with occasional stirring. After cooling, add 100mL of water and 10mL of nitric acid, and titrate with 0.05M silver nitrate solution(potentiometric titration). Perform a blank determination in the same manner.

$$1\text{mL of } 0.05\text{M silver nitrate solution} = 2.922\text{mg of NaCl}$$

(ii) Sodium glycolate : Weigh 0.5g of Cross-Linked Sodium Carboxymethyl Cellulose, add 2mL of acetic acid and 5mL of water, and stir for 15 minutes. Add gradually 50 mL of acetone with stirring, then add 1g of sodium chloride, stir for 3 minutes, and filter through a filter paper moistened with acetone. Wash the residue thoroughly with 30mL of acetone, combine the filtrate and washings, add acetone to make exactly 100mL. Allow to stand for 24 hours and use the clear supernatant as the test stock

solution. Separately, dissolve 0.100g of glycolic acid in water to make 200mL. Pipet 0.5mL, 1mL, 2mL, 3mL, and 4mL of this solution, add water to make them exactly 5mL, then add 5mL of acetic acid and acetone to make exactly 100mL, and designate them standard stock solution(1), standard stock solution(2), standard stock solution(3), standard stock solution(4), and standard stock solution(5), respectively. Pipet 2mL each of the test stock solution and the standard stock solutions(1), (2), (3), (4), and (5). Heat them in a water bath for 20 minutes to evaporate acetone. After cooling, add exactly 5mL of 2,7-dihydroxynaphthalene test solution, mix, then add 15mL of 2,7-dihydroxynaphthalene. Mix and cover the mouth of the vessel with aluminium foil. Heat in a water bath for 20minutes. After cooling, add sulfuric acid to make exactly 25mL, mix, and designate them test solution, standard solution(1), standard solution(2), standard solution(3), standard solution(4), and standard solution(5), respectively. Separately, add acetone to 10mL of mixture of water and acetic acid(1:1) to make exactly 100mL, and proceed with exactly 2mL of this solution in the same manner as described for the test solution. Use the solution as the blank solution. Using test solution, standard solutions(1), (2), (3), (4), and (5) as a reference, determine the absorbances, AT, AS1, AS2, AS3, AS4, and AS5 of the test solution, and the standard solutions (1), (2), (3), (4), and (5), respectively, at 540 nm using 1cm cells. Read the corresponding mg of glycolic acid in the 100mL test solution from the calibration curve. Then, calculate the sodium glycolate content from the following formula:

$$\% \text{ Sodium glycolate} = \frac{X \times 100 \times 1.2890}{\text{Weight of the sample(on the dried basis)}}$$

X : mg of glycolic acid read from the calibration curve

- (5) Arsenic : It should be no more than 4.0 ppm tested by Arsenic Limit Test.
- (6) Lead : When 5.0 g of Cross-Linked Sodium Carboxymethyl Cellulose is tested by Atomic Absorption Spectrophotometry or Inductively Coupled Plasma Emission Spectroscopy, its content should not be more than 2.0 ppm.
- (7) Cadmium : When 5.0 g of Cross-Linked Sodium Carboxymethyl Cellulose is tested by Atomic Absorption Spectrophotometry or Inductively Coupled Plasma Emission Spectroscopy, its content should not be more than 1.0 ppm.
- (8) Mercury : When Cross-Linked Sodium Carboxymethyl Cellulose is tested by Mercury Limit Test, its content should not be more than 1.0 ppm.

Loss on Drying When Cross-Linked Sodium Carboxymethyl Cellulose is dried at 105°C for 3 hours, the weight loss should not be more than 6.0%.

Residue on Ignition When thermogravimetric analysis is done with 2 g of Cross-Linked Sodium Carboxymethyl Cellulose, the amount of residue on the dry basis should be 14.0~28.0 %.

Crude Magnesium Chloride(Sea Water)

Definition Crude magnesium chloride (Sea Water and Salted Groundwater) is obtained by extracting and separating potassium chloride and sodium chloride from sea water, and its main ingredient is magnesium chloride. In the case of Salted Groundwater, it should be appropriate for the criteria for water quality of Salted Groundwater in 「Law for the Management of Drinking Water」(The Law of Ministry of Environment).

Compositional Specifications of Crude Magnesium Chloride (Sea Water)

Content The sample contains 12.0 ~ 30.0% as crude magnesium chloride ($\text{MgCl}_2=95.21$).

Description Crude magnesium chloride (Sea Water) is colorless~pale yellow liquid with bitter taste.

Identification (1) When sodium hydroxide solution is added to Crude Magnesium Chloride (Sea Water), white gel phase precipitate is formed. Iodine TS is added to some of this solution, the precipitate turns dark brown. Also, although excess sodium hydroxide TS is added to some of the residue in the solution, precipitate doesn't dissolve.

(2) Crude Magnesium Chloride (Sea Water) shows the reaction (A) for Chlorides in Identification Tests.

Purity (1) Sulfate : Accurately weighted 0.25 g of Crude Magnesium Chloride (Sea Water) and dissolve in water to make 100 mL. When 2 mL of this solution is tested for sulfates, the content should not be more than the amount that corresponds to 0.5 mL of 0.01 N sulfuric acid.

(2) Bromide : Accurately weigh 1.0 g of Crude Magnesium Chloride (Sea Water), and dissolve in water to make 500 mL. Take 10 mL of this solution, make 100 mL with water. Again, 2 mL of this solution is taken, 3 mL of water, 2 mL of diluted phenol red TS and 1 mL of chloramine T solution(1→10,000) are added, and immediately mixed. Then it is allow to stand for 2 minutes, 0.15 mL of 0.1N sodium thiosulfate is added, mixed, and water is added to make 10 mL, test solution. Separately, potassium bromide is dried at 110°C for 4 hours, 2.979g of the solid is accurately weighted, water is added to make 1,000 mL, again 2 mL of this solution is accurately taken, and water is added to make 1,000 mL. 5 mL of this solution is taken, 2 mL of diluted phenol red TS and 1 mL of chloramine T solution(1→10,000) are added, immediately shaken and mixed. It is proceeded in the same manner as the test solution, reference solution. Using water as a reference, absorbance of the test solution and reference solution is measured at 590 nm, then the absorbance of test solution should not be higher than that of reference solution.

Diluted phenol red TS

Solution 1 : To 0.033g of phenol red, 1.5 mL of sodium hydroxide solution(2→25) and water are added and dissolved to make 100 mL.

Solution 2 : To 0.025g of ammonium sulfate, 235 mL of water is added, dissolved, 105 mL of sodium hydroxide solution(2→25) and 135 mL of acetic acid(3→25) are added and mixed well.

10 mL of solution 1 and 190 mL of solution 2 are mixed well. If needed, sodium hydroxide

solution(2→25) or acetic acid (3→25) is added to adjust pH 4.7.

(3) Zinc: 4 g of Crude Magnesium Chloride (Sea Water) is accurately weighted, water is added to make 40mL, test solution. 30 mL of test solution is taken, 5 drops of acetic acid and 2 mL of potassium ferrocyanide solution(1→20) are added, shaken, mixed, and allow to stand for 10 minutes. The solution should not be more turbid than the following reference solution. To prepare reference solution, pipette 14mL of zinc standard solution, and add 10 mL of test solution and water to make 30mL. Add 5 drops of acetic acid and 2 mL of potassium ferrocyanide solution(1→20) to this solution, shake and mix, and allow to stand for 10 minutes. (not more than 70 ppm as Zinc)

Zinc standard solution : Accurately weigh 4.4g of zinc sulfate, dissolve with 1,000 mL water. Pipette 10 mL of this solution into a 1000 mL-volumetric flask with water to volume. 1mL of this solution contain 0.01 mg of zinc.

(4) Calcium : Accurately weigh 20 mL of test solution for assay, add water to make 100 mL. Add 0.2 mL of tartaric acid solution(1→5), then 10 mL of triethanol amine solution(3→10) and 10 mL of potassium hydroxide solution (1→10). Allow to stand for 5 minute, immediately titrate with 0.01 M EDTA determining endpoint indicator : 0.1 g of 2-oxy-1-(2'-oxy-4'-sulfo-1'-naphthylazo)-3-naphthoesan, and express the consumed volume as b (mL). At that time, the red-purple color of the solution completely disappears and the solution becomes blue. When the content of calcium calculate, it should not be more than 4.0% as calcium.

$$\text{Content of calcium(Ca)(\%)} = \frac{b \times 0.4008}{\text{Weight of sample(g)}}$$

(5) Sodium : 1.0 g of Crude Magnesium Chloride (Sea Water) is accurately weighted, water is added, and dissolved to make 1,000 mL. Again, 10 mL of this solution is taken and water is added to make 200 mL, test solution. Separately, sodium chloride is dried at 130°C for 2 hours, 2.542 g of the solid is accurately weighted, water is added to make 1,000 mL. 2 mL of this solution is accurately taken and water is added to make 1,000 mL, reference solution. When test solution and reference solution are tested by Flame Atomic Absorption Spectrophotometry under following operation condition, the absorbance of test solution should not be higher than that of reference solution (not more than 4.0% as sodium).

Operation Condition

Light source lamp : Hollow cathode sodium lamp

Wavelength : 589.0nm

Combustible support gas : air

Combustible gas : acetylene

(6) Potassium : Proceed the test by using test solution in Purity(5). Separately, potassium chloride is dried at 105°C for 2 hours, 1.907g of this solid is accurately weighted, and water is added to make 1,000 mL. 3 mL of this solution is taken, and water is added to make exactly 1,000 mL, reference solution. When test solution and reference solution are tested by Flame Atomic Absorption Spectrophotometry under following operation condition, the absorbance of test solution should not be higher than that of reference solution (not more than 6.0% as potassium).

Operating Conditions

Light source lamp : Hollow cathode potassium lamp

Wavelength : 766.5nm

Combustible support gas : air

Combustible gas : acetylene

(7) Arsenic : It should be no more than 4.0 ppm tested by Arsenic Limit Test.

(8) Lead : Crude Magnesium Chloride is tested by Purity (2) for Sodium Metaphosphate(not more than 4.0 ppm).

Assay Accurately weigh 2 g of Crude Magnesium Chloride (Sea Water) and add water to make 200mL, test solution. To 5 mL of this solution, 50 mL of water and 5 mL of ammonia-ammonium chloride buffer (pH 10.7), titrate with 0.01 M EDTA solution determining endpoint (indicator : 2 drops of Eriochrome black T solution), and measure the consumed volume as a (mL). At that time the red color of the solution becomes blue. Calculate the content under following equation with using the consumed volume b (mL) obtained by Purity(4).

$$\text{Content of magnesium chloride(MgCl}_2\text{) (\%)} = \frac{(a - 0.25b) \times 0.952 \times 200}{\text{Weight of sample(g)} \times 5 \times 1,000} \times 100$$

1 mL of 0.01M E.D.T.A solution = 0.952mg MgCl₂

Cupric Sulfate

Chemical Formula: $\text{CuSO}_4 \cdot 5\text{H}_2\text{O}$

Molecular Weight: 249.69

INS No.: 519

Synonyms: Copper sulfate

CAS No.: 7758-99-8

Compositional Specifications of Cupric Sulfate

Content Cupric Sulfate should contain within a range of 98.5 ~ 104.5% of cupric sulfate ($\text{CuSO}_4 \cdot 5\text{H}_2\text{O}$).

Description Cupric Sulfate occurs as a blue crystalline powder, powder or as deep blue crystals.

Identification Cupric Sulfate responds to the tests for Cupric Salt and Sulfate in Identification.

Purity (1) Clarity and Color of Solution : When 1 g of Cupric Sulfate is dissolved in 20 mL of water, the solution should be almost clear.

(2) Free Acid : Weigh 1 g of Cupric Sulfate, dissolve in 20 mL of water, and add 2 drops of methyl orange solution. A green color develops.

(3) Arsenic : It should be no more than 4.0 ppm tested by Arsenic Limit Test.

(4) Lead : When 5.0 g of Cupric Sulfate is tested by Atomic Absorption Spectrophotometry or Inductively Coupled Plasma Emission Spectroscopy, its content should not be more than 10 ppm.

(5) Alkali Metals and Alkali Earth Metals : Weigh 6 g of Cupric Sulfate, dissolve in 150 mL of water, add 3 mL of sulfuric acid, and pass through hydrogen sulfide while warming to about 70°C until the solution is saturated. Cool, add water to make 280 mL, and filter. To the filtrate, add water to make 300 mL. Measure 100 mL of this solution, evaporate to dryness on a sand bath, ignite at 450 ~ 550°C to constant weight, and weigh the residue. The amount of residue should not be more than 4 mg.

Assay Accurately weigh about 0.7 g of Cupric Sulfate, transfer into a flask with ground-glass stopper, dissolve in about 100 mL of water, add 2 mL of acetic acid and 5 g potassium iodide, immediately stopper tightly, and allow to stand in a dark place for 5 minutes. Titrate this solution with 0.1 N sodium thiosulfate until the color of the solution change to light yellow color, dissolve 2 g of ammonium thiocyanate, add 3 mL of starch solution, and titrate again with 0.1 N sodium thiosulfate until the color of the solution changes to an opaque color. Perform a blank test in the same manner.

1 mL of 0.1 N sodium thiosulfate = 24.97 mg of $\text{CuSO}_4 \cdot 5\text{H}_2\text{O}$

Curcumin

INS No.: 100(i), 100(ii)

CAS No.: 458-37-7

Synonyms: Turmeric oleoresin; Turmeric yellow

8024-37-1

Definition This is a pigment obtained by extraction(ethanol, oils or organic solvent(extraction solvents for spices and oleo resins) of tumeric i.e., the ground rhizomes of *Curcuma longa* Linné. The major pigment is curcumin ($C_{21}H_{20}O_6 = 368.37$). Dilutant, stabilizer, or solvent can be added for the purpose of color value adjustment and quality preservation.

Compositional Specifications of Turmeric Oleoresin (Curcumin)

Content Color value ($E_{1cm}^{10\%}$) of Turmeric Oleoresin should not be less than the indicated value.

Description Turmeric Oleoresin is yellow ~ dark reddish brown liquid, lump, powder, or paste with a slight characteristic odor.

Identification Turmeric Oleoresin is dissolved in ethyl alcohol (if it is water soluble, it is dissolved in small amount of water and then ethyl alcohol is added). The concentration is adjusted so that it has almost same tone of color as potassium bichromate solution (1→1,000) (Test Solution).

(1) Test Solution is characterized yellow color and a green fluorescence.

(2) Test Solution produced red when 2 mL of sulfuric acid is added to 5 mL of test solution and stirred.

(3) A piece of filter paper is dipped in Test Solution and dried. A few drops of hydrochloric acid, followed by a few drops of boric acid solution (1→100) are dropped onto the piece of filter paper. Upon drying by heating, it is developed cherry red. When a few drops of ammonia solution is added, it is changed blue.

Purity (1) Arsenic : It should be no more than 4.0 ppm tested by Arsenic Limit Test.

(2) Lead : When 5.0 g of Turmeric Oleoresin is tested by Atomic Absorption Spectrophotometry or Inductively Coupled Plasma Emission Spectroscopy, its content should not be more than 2.0 ppm.

(3) Residual Solvents : When Turmeric Oleoresin is tested by Purity (5) for 「Paprika Extract Pigments」, Methylene chloride, Trichloro ethylene Not more than 30ppm(single or the sum of both)

Acetone Not more than 30ppm

Isopropyl alcohol Not more than 30ppm

Methyl alcohol Not more than 50ppm

Hexane Not more than 25ppm

Assay Appropriate amount of Turmeric Oleoresin is precisely weighed so that the absorbance is within 0.3 ~ 0.7 and dissolved in ethyl alcohol to make 100 mL. 1 mL of this solution is diluted to 100 mL with ethyl alcohol (Test Solution). If necessary, the solution is centrifuged and the supernatant is used. Using

ethyl alcohol as a blank solution, absorbance A of the sample is measured at the maximum absorption at 425 nm in a 1cm cell. Color value is obtained using the following equation.

$$\text{Color Value} \left(\frac{E_{1\text{cm}}^{10\%}}{100} \right) = \frac{A \times 1,000}{\text{weight of the sample(g)}}$$

Curdlan

INS No.: 424

Synonyms: beta-1,3-Glucan

CAS No.: 54724-00-4

Definition Curdlan is obtained by separation and purification of polysaccharide produced from *Alcaligenes faecal* and *Agrobacterium*.

Compositional Specifications of Curdlan

Description Curdlan is white or nearly white powder.

Identification (1) When 10 mL of an aqueous suspension (1→50) of Curdlan is heated in a water bath, it forms a gel.

(2) 10 mL of sulfuric acid (2→5) is added to 10 mL of an aqueous suspension (1→50) of Curdlan, which is heated for 30 minutes in a water bath. After cooling, 1 mL of this suspension is diluted with 9 mL of water. While heating, it is neutralized with barium carbonate. When 2 mL of Fehling solution is added to 1 mL of the supernatant, which is boiled, red ~ dark red precipitates are formed.

Purity (1) Arsenic : It should be no more than 4.0 ppm tested by Arsenic Limit Test.

(2) Lead : When 5.0 g of Curdlan is tested by Atomic Absorption Spectrophotometry or Inductively Coupled Plasma Emission Spectroscopy, its content should not be more than 0.5 ppm.

(3) Nitrogen : When Curdlan is tested by Kjeldahl Nitrogen Test in nitrogen determination method, the amount should not be more than 0.3%.

(4) Total Viable Aerobic Count : When Curdlan is tested by Microbe Test Methods for Total Viable Aerobic Count (Number of General Germs) in General Test Method in 「Standards and Specifications for Foods」, it should not be more than 1,000 colonies per 1 g

(5) E. Coli : When Curdlan is tested by Microbe Test Methods for E. Coli in General Test Method 「Standards and Specifications for Foods」, it should be negative (-).

Residue on Ignition When Residue on Ignition is done with Curdlan, the amount of residue should not be more than 6.0%.

Loss on Drying When Curdlan is dried for 5 hours at 60°C under vacuum, the weight loss should not be more than 10.0%.

Cyclodextrin

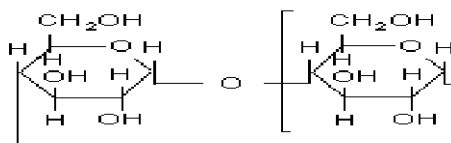

Chemical Formula:

α -cyclodextrin ($C_6H_{10}O_5$)₆

β -cyclodextrin ($C_6H_{10}O_5$)₇

γ -cyclodextrin ($C_6H_{10}O_5$)₈

Molecular Weight: 972.85

1134.99

1297.14

INS No.: 457, 459, 458

CAS No.: 10016-20-3

7585-39-9

17465-86-0

Definition (1) This is produced by the action of cyclodextrin producing enzyme on hydrolyzed starch. This is an cyclic oligosaccharide consisting of 6, 7, or 8 α -1,4 linked D-glucopyranosyl unit. There are α -cyclodextrin, β -cyclodextrin, and γ -cyclodextrin. Each of them is called α -cyclodextrin, β -cyclodextrin, and γ -cyclodextrin.

α -cyclodextrin : It is a cyclic oligosaccharide consisting of six D-glucose units. It is obtained by enzymetic treatment of starch

β -cyclodextrin : It is a cyclic oligosaccharide consisting of seven D-glucose units. It is obtained by enzymetic treatment of starch

γ -cyclodextrin : It is a cyclic oligosaccharide consisting of eight D-glucose units. It is obtained by enzymetic treatment of starch

Compositional Specifications of Cyclodextrin

Content When Cyclodextrin is dried and analyzed quantitatively, it should contain not less than 98.0% of each α -cyclodextrin($C_6H_{10}O_5$)₆, β -cyclodextrin($C_6H_{10}O_5$)₇, and γ -cyclodextrin ($C_6H_{10}O_5$)₈, respectively.

Description Cyclodextrin is odorless, white crystallite or crystalline powder having a slight sweet taste.

Identification 0.2 g of Cyclodextrin is dissolved in 1 mL of 0.1 N iodine solution by heating in a water bath. When it allowed to stand at room temperature, α -cyclodextrin, β -cyclodextrin, γ -cyclodextrin, maltosyl- α -cyclodextrin, maltosyl- β -cyclodextrin, maltosyl- γ -cyclodextrin forms bluish violet, yellowish brown, reddish brown, bluish violet, yellowish brown, and reddish brown precipitates are formed, respectively.

Purity (1) Clarity of Solution : 0.5 mg of sample is dissolved in 50 mL water, it should be colorless and clear.

- (2) Specific Rotation : Approximately 1 g of pre-dried sample is precisely weighed and dissolved in water so that the total volume becomes 100 mL. The optical rotation of the solution should be α -cyclodextrin $[\alpha]_D^{20} = +147.0 \sim +152.0^\circ$, β - cyclodextrin $[\alpha]_D^{20} = +160.0 \sim +164.4^\circ$, γ -cyclodextrin $[\alpha]_D^{20} = +173.0 \sim +178.0^\circ$
- (3) Chloride : When 0.5 g of Cyclodextrin is tested for chlorides, the amount should not be more than or equal to the chloride content of 0.25 mL of 0.01 N hydrochloric acid.
- (4) Arsenic : It should be no more than 1.0 ppm tested by Arsenic Limit Test.
- (5) Lead : When 5.0 g of Cyclodextrin is tested by Atomic Absorption Spectrophotometry or Inductively Coupled Plasma Emission Spectroscopy, its content should not be more than 1.0 ppm.
- (6) Residual Solvent : 0.25 g of Cyclodextrin is precisely weighed, 10 mL of water is added and diffused with ultrasonic waves for 10 minutes, test solution. This solution is transferred into 25 mL of frit sparger, and analyzed with Purge and Trap and Gas chromatograph. To 10 mL of water, 0.25 mL of mixed standard solution is added, analyzed with Purge and Trap and Gas chromatograph, then limited to β -cyclodextrin, the amount of toluene and trichloroethylene should not be more than 1.0 ppm, respectively.
- Mixed standard solution : 50 mg each of toluene and trichloroethylene is precisely weighed and dissolved in methanol to make 50 mL, 0.1 mL of this solution is taken again, and water is added to make 100 mL, mixed standard solution.(1 mL of this solution contains 1 μ g of toluene, and 1 μ g of trichloroethylene, respectively).

Operation Condition

Purge and Trap

Trap : Tenax TA or its equivalent

Purge time : 11 minutes

Desorption temperature and time : 250°C, 4 minutes

Cryo focus temperature : -150°C

Bake temperature and time : 260°C, 10 minutes

Gas chromatography

Column : DB-1(30m \times 0.32 μ m) or its equivalent

Detector : (Hydrogen) Flame Ionization Detector (FID)

Column Temperature : hold at 40°C for 3 minutes and is raised to 220°C at a rate of 40°C per minute

Detector Temperature : 250°C

Carrier gas and flow rate : Nitrogen or Helium

Loss on Drying When Cyclodextrin is dried for 4 hours at 105°C under a reduced pressure of 5 mmHg, the weight loss should not be more than 12%.

Residue on Ignition When residue on ignition is done with 1 g of Cyclodextrin, the amount of residue

should not be more than 0.1%.

Assay (1) After drying, approximately 0.1 g of Cyclodextrin is accurately weighed and dissolved in 10 mL of water (Test Solution). Separately, Standard for each of α -, β -, γ -cyclodextrin is dried. These standards are accurately weighed 0.1 g, and dissolved in 10mL of water, respectively (Standard Solution). 10 μ l each of Standard Solutions and Test Solution is injected into liquid chromatography under the following operation conditions. The content of cyclodextrin is calculated by the following formula.

$$\text{Content(\%)} = \frac{A_u \times W_s}{A_s \times W_u} \times 100$$

A_u : Peak area of Test Solution

A_s : Peak area of Standard Solution

W_s : Amount of standard taken (g)

W_u : Amount of sample taken(g)

Operation Conditions

-Detector : Differential refractometer (RI Detector)

-Column : Aminex HPX-42A (8 mm \times 300 mm) or its equivalent

-Column Temperature : a constant temperature at about 60 $^{\circ}$ C

-Mobile Phase : Water

-Flow Rate : 0.6~1.0 mL/min

Cyclodextrin Syrup

Definition Cyclodextrin Syrup is a starch hydrolysate by purifying and concentrating aqueous solution (containing cyclodextrin), which is prepared by treating starch latex with cyclodextrin producing enzyme. It contains sugars such as α -cyclodextrin, β -cyclodextrin, γ -cyclodextrin, glucose, and maltose, where 6, 7, or 8 molecules of glucose form a ring via α -1,4 glucoside bonding. Dried cyclodextrin syrup also falls within this category.

Compositional Specifications of Cyclodextrin Syrup

Content Dried Cyclodextrin Syrup should be more than the indicated content of cyclodextrin under Assay.

Description Cyclodextrin Syrup is colorless transparent viscous liquid or white powder. It is sweet but scentless. It tends to form white precipitates and turn turbid in cold places.

Identification (1) When 0.5 g of Cyclodextrin Syrup is dissolved in 1 mL of 0.1 N iodine solution by heating in a water bath and set aside at room temperature, yellowish brown precipitates are formed. (2) 0.5 g of Cyclodextrin Syrup is dissolved in 3 mL of water by heating in a water bath. When 1 mL of trichloroethylene is added to this solution and stirred vigorously, it turns white and turbid.

Purity (1) Clarity of Solution : 2 g of Cyclodextrin Syrup is dissolved in 50 mL of water by heating. The resulting should be colorless and clear (or better). (2) Arsenic : It should be no more than 1.0 ppm tested by Arsenic Limit Test. (3) Lead : When 5.0 g of Cyclodextrin Syrup is tested by Atomic Absorption Spectrophotometry or Inductively Coupled Plasma Emission Spectroscopy, its content should not be more than 1.0 ppm. (4) Chloride : Weight 0.5 g of Cyclodextrin Syrup for Chloride Limit Test. The content of chloride should be equal to or less than the amount that corresponds to 0.4 mL of 0.01 N hydrochloric acid.

Loss on Drying When Cyclodextrin Syrup is dried for 4 hours at 105°C under a reduced pressure less than 5 mmHg, the weight loss should not be more than 25%.

Residue on Ignition When thermogravimetric analysis is done with 1 g of Cyclodextrin Syrup, the amount of residue should not be more than 0.05%.

Assay Cyclodextrin Syrup (corresponding to 0.5 g of cyclodextrin) is precisely weighted and diluted to 50 mL with water. 20 mL of this solution is heated for 10 minutes in a water bath and cooled. 2 mL of glucoamylase (10 IU/mL) is added to the solution, which is then reacted for 1 hour in a 40°C water bath. The reaction mixture is heated for 10 minutes in a water bath and filtered. The filtrate is cooled to room temperature and diluted to 25 mL with water (Test Solution). Separately, α -, β -, γ -cyclodextrin standards are dried. 0.1 g each is weighted and dissolved in water to bring the total volume to 20 mL (Mixed Standard Solution). 10 μ each of Test Solution and Mixed Standard Solution is injected into a high speed liquid chromatography under the following operation conditions. Peak areas of α -, β -, γ -cyclodextrin are obtained for Test Solution and Mixed Standard Solution. The contents of three components are obtained by the following equation and the content of cyclodextrin is obtained from the sum of the three.

Content of cyclodextrin (CD) (%) = Content sum of α -CD + β -CD + γ -CD (%)

$$\text{Content of } \alpha\text{-CD}(\%) = \frac{\text{concentrate of } \alpha\text{-CD standard solution(ppm)} \times 50 \times 25}{\text{weight of the sample(g)} \times 20} \times \frac{\alpha\text{-CD peak area in test solution}}{\text{peak area of } \alpha\text{-CD mixed standard solution}} \times \frac{100}{10^6}$$

$$\text{Content of } \beta\text{-CD}(\%) = \frac{\text{concentrate of } \beta\text{-CD standard solution(ppm)} \times 50 \times 25}{\text{weight of the sample(g)} \times 20} \times \frac{\beta\text{-CD peak area in test solution}}{\text{peak area of } \beta\text{-CD mixed standard solution}} \times \frac{100}{10^6}$$

$$\text{Content of } \gamma\text{-CD}(\%) = \frac{\text{concentrate of } \gamma\text{-CD standard solution(ppm)} \times 50 \times 25}{\text{weight of the sample(g)} \times 20} \times \frac{\gamma\text{-CD peak area in test solution}}{\text{peak area of } \gamma\text{-CD mixed standard}} \times \frac{100}{10^6}$$

Operation Conditions

- Detector : Differential refractometer (RI Detector)
- Column : Aminex HPX-42A (8 mm × 300 mm) or its equivalent
- Column Temperature : A constant temperature near 80°C
- Mobile Phase : Water
- Flow Rate : 0.6~1.0 mL/min

L-Cysteine Monohydrochloride

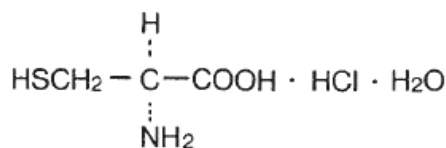

Chemical Formula: $\text{C}_3\text{H}_7\text{NO}_2\text{S} \cdot \text{HCl} \cdot \text{H}_2\text{O}$

INS No.: 920

Molecular Weight: 175.63

CAS No.: 7048-04-6

Compositional Specifications of L-Cysteine Monohydrochloride

Content L-Cystein Monohydrochloride, when calculated on the dried basis, should contain within a range of 98.0 ~ 102.0% of L-cysteine monohydrochloride ($\text{C}_3\text{H}_7\text{NO}_2\text{S} \cdot \text{HCl} = 157.62$).

Description L-Cystein Monohydrochloride occurs as colorless to white crystals or as a white crystalline powder, having a characteristic odor and taste.

Identification (1) To 5 mL of L-Cysteine Monohydrochloride solution (1→1,000), add 0.5 mL of pyridine and 1 mL of ninhydrin solution (1→100), and heat for 5 minutes. A purple to purple-brown color develops.

(2) To 10 mL of L-Cystein Monohydrochloride solution (1→1,000), add 2 mL of sodium hydroxide solution and 2 drops of sodium nitroprusside solution. A purple-red color develops.

(3) To 10 mL of L-Cysteine Monohydrochloride solution (1→50), add 1 mL of hydrogen peroxide, and heat in a water bath for 10 minutes. The solution respond to the test for Chloride Limit Test (2) in Identification.

Purity (1) Clarity and Color of Solution : When 1 g of L-Cystein Monohydrochloride is dissolved in 20 mL of water, the solution should be colorless and should not be more than clear.

(2) Specific Rotation : Approximately 4 g of L-Cystein Monohydrochloride is precisely weighed, which is dissolved in 1 N hydrochloric acid so that the total volume becomes 50 mL. When optical rotation of the solution is measured, it should be $[\alpha]_D^{20} = +5.0 \sim +8.0^\circ$

(3) Arsenic : It should be no more than 2.0 ppm tested by Arsenic Limit Test.

(4) Lead : When 5.0 g of L-Cystein Monohydrochloride is tested by Atomic Absorption Spectrophotometry or Inductively Coupled Plasma Emission Spectroscopy, its content should not be more than 5.0 ppm.

(5) Cystine : Weigh 100 mg of L-Cysteine Monohydrochloride, dissolve in 50 mL of N-ethylmaleimide solution (1→50), and allow to stand for 2 hours. Use this solution as the test solution. Measure 5 μl the test solution, perform Paper Chromatography using an n-butyl alcohol, glacial acetic acid, and water mixture (5:1:2) as the developing solvent. Only one spot should be observed. For the filter paper,

use a No. 2 filter paper for chromatography. Stop the development when the developing solvent front rises about 30 cm. Air-dry, then dry at 100°C for 20 minutes, spray with a solution of ninhydrin saturated n-butyl alcohol (1→500), and heat at 100°C for 5 minutes to develop a color. Observe under natural light. Reference solution is not used.

Loss on Drying L-Cystein Monohydrochloride is dried for 24 hours in a vacuum desiccator (silica gel) and the weight loss should be within a range of 8~12%.

Residue on Ignition When thermogravimetric analysis is done with L-Cystein Monohydrochloride 1 g in a quartz or porcelain crucible, the amount of residues should not be more than 0.1%.

Assay Dissolve 0.25 g of L-Cysteine Monohydrochloride, previously dried and accurately weighed, in 20 mL of water, and add 4 g of potassium iodide to dissolve in this solution. To this solution, add 5 mL of diluted hydrochloric acid and 25 mL of 0.1 N iodine, and allow to stand in ice water for 20 minutes in a dark place. Titrate the excess iodine with 0.1 N sodium thiosulfate solution (indicator: starch solution). Separately, perform a blank test by the same procedure.

0.1 N iodine 1 mL = 15.76 mg of $C_3H_7NO_2S.HCl$

L-Cystine

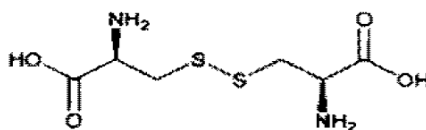

Chemical Formula: $C_6H_{12}N_2O_4S_2$

INS No.: 921

Molecular Weight: 240.30

CAS No.: 56-89-3

Compositional Specifications of L-Cystine

Content L-Cystine, when calculated on dried basis for 3 hours in a desiccator with phosphorous pentoxide, should contain within a range of 98.0~102.0% of L-Cystine ($C_6H_{12}N_2O_4S_2$).

Description L-Cystine is white crystal or crystalline powder having a characteristic odor. It is no taste or has a characteristic taste.

Identification (1) To 5 mL of L-Cysteine saturated solution, add 1 mL of ninhydrin solution(1→50), and heat for 3 minutes. A purple color develops.

(2) To 3mL of 2N hydrochloric acid (1→30), add 0.04 g of zinc powder and heat in a water bath for 10 minutes. If there is need to cool, do cooling and filtering it. Add 10 mL of sodium hydroxide solution(1→20) and shake it to mix. When 1 drop of sodium nitroprusside solution is added, a purple-red color develops.

Purity (1) Clarity and Color of Solution : When 1 g of L-Cystein is dissolved in 20 mL of 1N hydrochloric acid, the solution should be colorless and clear.

(2) Acidity, and Alkalinity : pH of L-Cystine saturated solution should be within a range of 5.0~6.5.

(3) Specific Rotation : 2 g of pre-dried L-Cystine is dissolved in 1 N hydrochloric acid, where the total volume of the solution is 100 mL. Optical rotation of this solution should be within a range of $[\alpha]_D^{20}$ = -215 ~ -225°.

(4) Chloride: When 0.07 g of L-Cystine is tested by Chloride Limit Test, its content should not be more than the amount that corresponds to 0.2 mL of 0.01 N hydrochloric acid (Not more than 0.1%).

(5) Arsenic : It should be no more than 4.0 ppm tested by Arsenic Limit Test.

(6) Lead : When 5.0 g of L-Cystine is tested by Atomic Absorption Spectrophotometry or Inductively Coupled Plasma Emission Spectroscopy, its content should not be more than 5.0 ppm.

Loss on Drying When L-Cystine is dried for 3 hours at 105°C, the weight loss should not be more than 0.2%.

Residue on Ignition When thermogravimetric analysis is done with 2 g of L-Cystine, the amount of residue should not be more than 0.1%.

Assay After drying L-Cysteine, weigh precisely 300 mg. It is tested by Kieldahl method of Nitrogen determination method to obtain amount of nitrgen(N). And L-Cysteine is obtained below formula.

$$\text{Amount of L-Cystine in the sample (\%)} = N \times 8.58$$

5'-Cytidylic acid

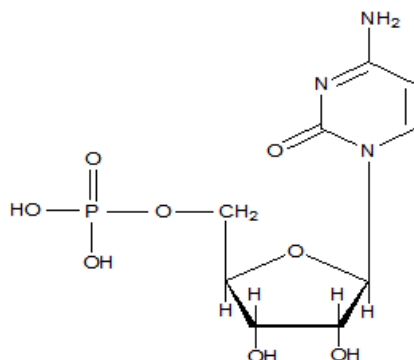

Chemical Formula: $C_9H_{14}N_3O_8P$

Molecular Weight: 323.20

CAS No.: 63-37-6

Definition 5'-Cytidylic acid is obtained by enzymatically hydrolyzing and separating hexane that is obtained by extracting yeast (*Candida utilis*, *Kluyveromyces fragilis*) with hot water under a presence of salts. Its component is 5'-cytidylic acid.

Compositional Specifications of 5'-Cytidylic acid

Content If 5'-Cytidylic acid is converted to a dehydrated form, it should contain 98.0~102.0% 5'-cytidylic acid ($C_9H_{14}N_3O_8P$).

Description 5'-Cytidylic acid is white crystalline powder.

Identification (1) 0.2 g of 5'-Cytidylic acid is precisely weighted and dissolved in 10 mL of 0.1 N sodium hydroxide solution, which is diluted to 200 mL with water. 2 mL of this solution is diluted to 100 mL with 0.01 N hydrochloric acid. The resulting solution has a maximum absorption band near 280 nm.

(2) 1 mL of hydrochloric acid and 1 mL of bromine solution are added to 3 mL aqueous solution of 5'-Cytidylic acid (3→10,000), which is then heated for 30 minutes. Bromine is removed in a flowing air. 0.2 mL of orcin solution in alcohol (1→10) is added to this solution. To the resulting solution, 3 mL of ammonium ferric sulfate-hydrochloric acid solution (1→1,000) is added and heated for 20 minutes in a water bath. The final solution turns green.

(3) 0.25 g of 5'-Cytidylic acid is precisely weighted and dissolved in 1 mL of sodium hydroxide solution (1→25), which is diluted to 5 mL of water. When 2 mL of magnesia solution is added to this solution, precipitates are not observed. To resulting solution, 7 mL of nitric acid is added and boiled for 10 minutes in a water bath. When the resulting solution is neutralized with sodium hydroxide solution (1→25), it shows the reaction of (B) Phosphate Salts in Identification.

Purity (1) Arsenic : It should be no more than 4.0 ppm tested by Arsenic Limit Test.

- (2) Lead : When 5.0 g of 5'-Cytidylic acid is tested by Atomic Absorption Spectrophotometry or Inductively Coupled Plasma Emission Spectroscopy, its content should not be more than 10.0 ppm.
- (3) Solution: 0.5g of 5'-Cytidylic acid is weighted and dissolved in 2mL of sodium hydroxide solution, which is diluted to 20mL with water. the solution is nearly colorless and clear.
- (4) Other nucleic acid hydrolysates: 0.1g of 5'-Cytidylic acid is weighted and dissolved in 0.5mL of sodium hydroxide solution, which is diluted to 20mL with water. When 1 $\mu\ell$ of the test solution is tested with the mixed solution of acetone-ammonia solution-n-propanol (2:5:6) by Thin Layer Chromatography, it should not show spots except for one original spot. Supporting material of thin layer plate must be used as dried one with silicagel(added fluorescent agent) for 1 hour at 110°C. When the solvent is developed up to 10cm from the base line, stop the developing. After drying with wind, the plates are observed under a UV light (about 250nm wavelength). The control solution is not used.
- (5) Absorption Ratio : 20 mg of 5'-Cytidylic acid is precisely weighted and dissolved in hydrochloric acid (1 \rightarrow 1,000) (total volume = 1,000 mL). Absorptions A_1 , A_2 , and A_3 are measured at 250 nm, 260 nm, and 280 nm are measured. A_1/A_2 and A_3/A_2 should be 0.40 ~ 0.52 and 1.85 ~ 2.20, respectively.

Loss on Drying When 5'-Cytidylic acid is dried for 4 hours at 120°C, the weight loss should not be more than 6.0%.

Assay 0.2 g of 5'-Cytidylic acid is precisely weighted and dissolved in 10 mL of 0.1 N sodium hydroxide solution, which is diluted to 200 mL with water. 2 mL of this solution is further diluted to 100 mL with 0.01 N hydrochloric acid (Test Solution). Absorption A of Test Solution is measured at 280 nm with 1cm path length using 0.01 N hydrochloric acid as a reference. The content of 5'-adenylic acid is obtained by the following equation.

$$\text{Content(\%)} = \frac{0.2}{\text{weight of the sample(g)}} \times \frac{127.2 \times A}{100 - \text{loss on drying(\%)}} \times 100$$

Dammar Gum

Synonyms: Dammar resin

CAS No.: 9000-16-2

Definition Dammar Gum is obtained by drying exudates of trees of *Agathis*, *Hopea*, or *Shorea* genus. It consists of polysaccharides and acidic and neutral terpenoid compounds.

Compositional Specifications of Dammar Gum

Description Dammar Gum is white, pale yellow ~ dark brown transparent or semitransparent granular or solid resin.

Identification 20 µl of 10% solution of Dammar Gum in chloroform is spotted on a pre-activated 0.2 mm silica gel (Merck F₂₅₄ or its equivalent) for Thin Layer Chromatography. It is then developed using a solution of ethyl ether and hexane (30 : 25). Sulfuric acid is sprayed on the plate, which is then dried for 3 minutes at 180°C. Two dark spots at R_f values of 0.8 and 0.7 are observed.

Purity (1) Lead : When 5.0 g of Dammar Gum is tested by Atomic Absorption Spectrophotometry or Inductively Coupled Plasma Emission Spectroscopy, its content should not be more than 2.0 ppm.

(2) Acid Value : Approximately 5 g of Dammar Gum Dissolve in 30 mL of toluene and 30 mL of neutralized ethyl alcohol. This is used as test solution. The test solution is proceeded as directed under Acid value in Fats Test. The Acid value of the solution should be 20~40.

(3) Iodine Value : Approximately 1 g of Dammar Gum is precisely weighted into a 500 mL Erlenmeyer flask with a stopper and 20 mL of glacial acetic acid/cyclohexane, 1:1, v/v is added to dissolve the material. After adding 25 mL of Weiss solution, a stopper is placed, shaken and let stand in the dark for 1 hour where the iodine value is <150 and for 2 hours where the iodine value is ≥150. 20 mL of potassium iodide solution and 100 mL of water (previously boiled and cooled) are added to the flask. Titrate the excess iodine with 0.1N sodium thiosulfate solution, adding the titrant gradually and shaking constantly until the yellow colour of the solution almost disappears. Add starch test solution, and continue the titration until the blue colour disappears entirely. Toward the end of the titration, stopper the container, shake it vigorously. Saperately, perform determination on blank in the same manner. The iodine Value should be 10 ~ 40. Separately, a blank test is carried out by the same procedure.

$$\text{Iodine Value} = \frac{(A - B) \times 1.269}{C}$$

A : Consumed amount of 0.1 N sodium thiosulfate solution in the blank test (mL)

B : Consumed amount of 0.1 N sodium thiosulfate solution in the test for sample (mL)

C : Amount of sample(g)

(4) Melting Point : Melting point should be in a temperature range of 90~95°C.

(5) Softening Point : Softening point should be 86~90°C.

(6) E. coli : Pasteurized saline solution is added to 25 g of Dammar Gum (total volume = 250 mL). It is tested by the (2) Allowed Limit Test in Microbiological Methods for E. coli in General Testing Methods in 「Standards and Specifications for Foods」. It should be negative.

(7) Salmonella : Pasteurized saline solution is added to 25 g of Dammar Gum (total volume = 250 mL). It is tested by the Microbiological Methods for Salmonella in General Testing Methods in 「Standards and Specifications for Foods」. It should be negative.

Ash When Dammar Gum tested by Ash and Acid-Insoluble Ash Limit, the amount of ash should not be more than 0.5%.

Loss on Drying When Dammar Gum is dried for 18 hours at 105°C, the weight loss should not be more than 6%.

5'-Deaminase

Definition 5'-Deaminase is an enzyme obtained from cultures of *Aspergillus melleus*. Dilutant or stabilizer can be added for the purpose of activity adjustment and quality preservation.

Compositional Specifications of 5'-Deaminase

Description 5'-Deaminase is white ~ dark brown power, granular, pasty substances or colorless ~ dark brown liquid.

Identification When 5'-Deaminase is proceeded as directed under Activity Test, it should have the activity as 5'-Deaminase.

Purity (1) Arsenic : It should be no more than 4.0 ppm tested by Arsenic Limit Test.

(2) Lead : When 5.0 g of 5'-Deaminase is tested by Atomic Absorption Spectrophotometry or Inductively Coupled Plasma Emission Spectroscopy, its content should not be more than 5.0 ppm.

(3) Coliform Group : 5'-Deaminase proceed as directed under Microbe Test Methods in Coliform Group in General Test Methods in 「Standards and Specifications for Foods」. It should contain not more than 30 colonies per 1 g of this product.

(4) Salmonella : When 5'-Deaminase is tested by Microbe Test Methods for Salmonella in General Test Method 「Standards and Specifications for Foods」, it should be negative (-).

(5) E. Coli : When 25 g of 5'-Deaminase is tested by Microbe Test Methods for E. Coli in General Test Method 「Standards and Specifications for Foods」, it should be negative (-).

Activity Test (activity)

Analysis principle : Activity test is based on measuring the absorbance of the mixture in the following manner: react the 5'-Deaminase with adenosine 5'-monophosphate disodium substrate to produce inosine 5'-monophosphate sodium, measure absorbance of the rest of adenosine 5'-monophosphate disodium and inosine 5'-monophosphate sodium at the most great difference of absorbance wavelength 265nm.

Preparation of Test Solution : When 5'-Deaminase is weighted, use water or phosphate buffer solution so that 1 $\mu\ell$ of the final diluent solution contains 5~30 5'-Deaminase unit.

Procedure : Take 3 mL of substrate solution into tube, keep it at $37\pm 0.5^\circ\text{C}$ precisely for 5 minutes. Then add precisely 1 mL of test solution and immediately shake it to mix. Keep this solution at $37\pm 0.5^\circ\text{C}$ precisely for 15 minutes. Then add 4 mL of diluent perchloric acid(1→30) and immediately shake it to mix. Take precisely 2 mL of this solution and add water to make to 100 mL. Using water as a reference solution, absorbance(A_T) is measured at wavelength 265 nm. Separately, take 3 mL of substrate solution and 4 mL of diluent perchloric acid(1→30) into tube and immediately shake it to mix. And then add 1 mL of test solution and immediately shake it to mix. Take precisely 2 mL of this solution and add water to make to 100 mL. Using water as a reference solution, absorbance(A_B) of blank enzyme test solution is measured at wavelength 265 nm.

Activity of an enzyme is calculated by the following equation.

$$5'\text{-Deaminase (units/g)} = (A_B - A_T) \times \frac{10}{0.001} \times \frac{8}{2} \times \frac{60}{15} \times \frac{1}{W}$$

A_B : Absorbance of blank enzyme test solution

A_T : Absorbance of test solution

10/0.001 : Unit Conversion Factor(When difference in absorption is 0.001, it corresponds to 10 unit)

W : Weight of sample in 1 mL of test solution(g)

Definition of Activity : 1 5'-Deaminase unit corresponds to the amount of enzyme which decreases 0.001 of difference in absorption for 60 minutes under the conditions above.

Reagent

Substrate solution : Dry adenosine 5'-monophosphate disodium in advance at 105°C for 4 hours. And calculate loss on drying. Weigh precisely 330.2 mg as the dried basis and dissolve it in about 25 mL of water. Adjust pH to 6.0 with 4N sodium hydroxide solution or 2N hydrochloric acid and add water to make to 100 mL. When using it, it is used as the mixture solution. The mixing ratio of this solution and 1/15M Phosphate buffer solution(pH 5.6) is 1:2.

1/15M phosphate buffer solution(pH 5.6) : Dissolve 9.07 g of potassium dihydrogen phosphate in water to make to 1,000 mL(A solution) and dissolve 9.46 g of anhydrate disodium hydrogen phosphate in water to make to 1,000 mL(B solution). The mixing ratio of A solution and B solution is 14:1. Adjust pH to 5.6.

Storage Standard of 5'-Deaminase

5'-Deaminase should be stored in a hermetic container in a cold dark place.

Decanal

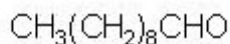

Chemical Formula: $\text{C}_{10}\text{H}_{20}\text{O}$

Molecular Weight: 156.27

Synonyms: Decyl aldehyde

CAS No.: 112-31-2

Compositional Specifications of Decanal

Content Decanal should contain not less than 92.0% of decanal ($\text{C}_{10}\text{H}_{20}\text{O}$).

Description Decanal occurs as transparent liquid of a colorless to light yellow. It has a characteristic odor.

Identification To 1 mL of Decanal, add 3 mL of sodium hydrogen sulfite solution, and shake. Immediately, the solution evolves and forms crystalline lumps.

Purity (1) Specific Gravity : Specific gravity of Decanal should be within a range of 0.823 ~ 0.832

(2) Refractive Index : Refractive Index n_D^{20} of Decanal should be within a range of 1.426 ~ 1.430

(3) Clarity and Color of Solution : When 2 mL of Decanal is dissolved in 2 mL of 80% ethanol, the solution should be clear.

(4) Acid Value : Acid value of Decanal is tested by Acid Value in Flavoring Substance Test. It should not be more than 10.

Assay Accurately weigh about 1 g of Decanal, and proceed as directed under Method 2 in Aldehyde and Ketone Content in Flavoring Substances Tests. In the procedure, allow the mixture to stand for 15 minutes before titrating.

1 mL of 0.5 N hydrochloric acid = 78.13 mg of $\text{C}_{10}\text{H}_{20}\text{O}$

Decanol

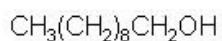

Chemical Formula: $\text{C}_{10}\text{H}_{22}\text{O}$

Molecular Weight: 158.28

Synonyms: Decyl alcohol

CAS No.: 112-30-1

Compositional Specifications of Decanol

Contents Decanol should contain not less than 98.0% of decanol ($\text{C}_{10}\text{H}_{22}\text{O}$).

Description Decanol is a colorless ~ pale yellow, transparent liquid having a characteristic odor.

Identification To 2 ~ 3 drops of Decanol, add 5 mL of potassium permanganate solution (1→20) and 1 mL of diluted sulfuric acid, and shake. An odor of Decyl aldehyde is evolved.

Purity (1) Solidification Temperature : Solidification Temperature of Decanol should not be less than 5°C.

(2) Specific Gravity : Specific gravity of Decanol should be within a range of 0.826 ~ 0.831.

(3) Refractive Index : Refractive Index n_D^{20} of Decanol should be within a range of 1.435 ~ 1.439.

(4) Clarity and Color of Solution : When 1mL of Decanol is dissolved in 3 mL of 60% ethanol, the solution should be clear.

(5) Acid Value: Acid value of Decanol is tested by Acid Value in Flavoring Substance Test. It should not be more than 1.

Assay Proceed as directed under Method 1 in Alcohol Content Measurement in Flavoring Substance Test. In this case, approximately 1 g of acetylated oil is used.

Dextran

Definition Dextran is obtained by separating from culture medium of gram positive bacteria (*Leuconostoc mesenteroides*, *Streptococcus bovis* ORLA-JENSEN) and its main ingredient is dextran.

Composition Specifications of Dextran

Description Dextran is a white ~ pale yellow powder or solid without smell.

Identification When 2 mL of anthrone is added to 1 mL of the aqueous solution (1→3000) of Dextran, greenish blue appears, which becomes slowly to dark blue. Again 1 mL of sulfuric acid (1→2) or 1 mL of acetic acid is added, and then the color does not change.

Purity (1) Arsenic : It should be no more than 4.0 ppm tested by Arsenic Limit Test.

(2) Lead : When 5.0 g of Dextran is tested by Atomic Absorption Spectrophotometry or Inductively Coupled Plasma Emission Spectroscopy, its content should not be more than 5.0 ppm.

(3) Total Viable Aerobic Count : When Dextran is tested by Microbe Test Methods for Total Viable Aerobic Count (Number of General Germs) in General Test Method in 「Standards and Specifications for Foods」, it should not be more than 5,000 per 1 g

(4) E. Coli : When 25 g of Dextran is tested by Microbe Test Methods for E. Coli in General Test Method 「Standards and Specifications for Foods」, it should be negative (-).

(5) Total nitrogen : When 0.5 g of Dextran is precisely weighed, proceed as directed under Kjeldahl Method in Nitrogen Determination, the amount should not be more than 1.0%.

Residue on Ignition When Dextran proceed as directed under Residue on Ignition, the amount should not be more than 2.0%.

Loss on Drying When Dextran is dried at 105°C for 5 hours, the weight loss of Dextran should not be more than 10.0%.

Dextranase

1, 6- α -D-glucan 6-glucanohydrolase

Definition Dextranase is an enzyme obtained from a culture of *Chaetomium gracile*. Dilutant or stabilizer can be added for the purpose of activity adjustment and quality preservation.

Compositional Specifications of Dextranase

Description Dextranase is white ~ dark brown powder, particle, paste or colorless ~ dark brown liquid.

Identification When Dextranase is proceeded as directed under Activity Test, it should have the activity as Dextranase.

Purity (1) Arsenic : It should be no more than 4.0 ppm tested by Arsenic Limit Test.

(2) Lead : When 5.0 g of Dextranase is tested by Atomic Absorption Spectrophotometry or Inductively Coupled Plasma Emission Spectroscopy, its content should not be more than 5.0 ppm.

(3) Coliform Group : When Dextranase proceed as directed under Microbiological Methods for Coliform Group in General Testing Methods in 「Standards and Specifications for Foods」, it should not contain more than 30 per 1 g of this product.

(4) Salmonella : When Dextranase proceed as directed under Microbiological Methods for Salmonella in General Testing Methods in 「Standards and Specifications for Foods」, it should be negative (-).

(5) E. Coli : When Dextranase is tested by Microbe Test Methods for E. Coli in General Test Method 「Standards and Specifications for Foods」, it should be negative (-).

Activity Test (activity) Analysis Principle : Activity test is based on hydrolysis of dextran substrate at pH 5.1, 40°C temperature.

◦Preparation of Test Solutions : An appropriate amount of sample is diluted with phosphate buffer solution adjusting pH 7.0 so that 1 mL contains 8~12 Unit.

◦Test Procedure : 2.0 mL of substrate solution placed in the test tube is isothermalized for 10 minutes in a 40 ± 1°C water bath. Exactly 1.0 mL of Test Solution is added to this substrate solution and mixed well by shaking. After exactly 10 minutes, 0.5 mL of 2 N sulfuric acid is added to the solution, which is set aside for 10 minutes at room temperature. 1 drop of phenolphthalein TS is added to the resulting solution, which is then neutralized with sodium hydroxide solution. It is then well mixed with 0.5 mL of water and 5 mL of alkaline copper solution. For enzyme blank test, 2.0 mL of substrate solution and 0.5 mL of 2 N sulfuric acid are well mixed, where 1.0 mL of Test Solution is added. The same procedure as the Test Solution is followed for enzyme blank test. Separately, 1.0 mL and 2.0 mL of glucose standard solution are diluted to 5.0mL with water, where 5 mL each of alkaline copper solution is added. For a blank test for glucose standard solution, a mixture of 5.0 mL each water and alkaline copper solution is prepared. All the test tubes are boiled for 20 minutes in a boiling water bath. Cool the solution, and isothermalize the tubes in a 40 ± 1°C water bath and set aside until precipitates are formed at the bottom of the tubes. 2.0 mL of potassium iodide solution and 10 mL of 2 N sulfuric acid are added to the test tubes. It is quickly titrated with 0.005 N sodium thiosulfate solution until the color of Iodine

disappears. After adding 1.0 mL of starch solution, it is again titrated by drop-wise adding 0.005 N sodium thiosulfate solution until the blue color disappears.

Enzyme activity is calculated by the following equation.

$$\text{Dextranase unit/g} = F \times (B - A) \times \frac{1}{\text{weight of the sample(g)}} \times 2.775 \times 10^3$$

B : Consumed amount of 0.005 N sodium thiosulfate for enzyme blank test (mL)

A : Consumed amount of 0.005 N sodium thiosulfate for the test (mL)

F : factor of reducing sugar

Linearity of the glucose standard solution is inspected as follows.

$$0.98 < \frac{2 \times (W - S_1)}{W - S_2} < 1.02$$

W : Consumed amount of 0.005 N sodium thiosulfate for blank test (mL)

S₁ : Consumed amount of 0.005 N sodium thiosulfate per 1.0mL of glucose standard solution (mL)

S₂ : Consumed amount of 0.005 N sodium thiosulfate per 2.0mL of glucose standard solution (mL)

If the measurement does not satisfy the above condition, it is discarded.

Definition of Activity : 1 Dextranase unit corresponds to an amount of enzyme that generates reducing sugar that corresponds to 1 μmo1 of glucose per minute under the above test conditions.

Solutions

- 0.1 M Acetate Buffer Solution : 0.1 M acetic acid is mixed with 0.1 M sodium acetate solution and pH is adjusted to 5.1.
- Phosphate Buffer Solution (pH 7.0) : 2.7 g of potassium phosphate, mono basic and 10.7 g of sodium phosphate, dibasic (12 hydrates) are dissolved in water (total volume = 500 mL). 100 mL of this solution is added with water to 1,000 mL.
- Potassium Iodide Solution : 2.5 g of potassium iodide is dissolve in water (total volume = 100 mL).
- Alkaline Copper Solution : 71 g of sodium phosphate, dibasic (12 hydrates) and 40 g of potassium sodium tartrate are dissolved in 650 mL of water, where 100 mL of sodium hydroxide solution is added. While stirring slowly, 80 mL of copper sulfate solution (10→100) and 180 g of anhydrous sodium sulfate are added and dissolved. 25 mL of potassium iodate solution (3.567→100) is added to the resulting

solution, which is diluted to 1,000 mL with water.

- 0.005 N sodium thiosulfate solution : 0.1 N sodium thiosulfate solution is diluted to twenty times a capacity with freshly boiled and cooled water.
- Substrate Solution : 2.5 g of dextran (Dextran T 2000, Pharmacia-Fine Chemical AB Upsala Sweden, or its equivalent) is precisely weighted and dissolved in 100 mL of 0.1 M acetate buffer solution.

Storage Standards of Dextranase

Dextranase is strongly hygroscopic. Store in a cold dark place and well-closed containers.

Diastase(Diastatic Power, DP)

Definition Diastase is an enzyme obtained from malt. Dilutant or stabilizer can be added for the purpose of activity adjustment and quality preservation.

Compositional Specifications of Diastase

Description Diastase is white ~ deep brown powder, particles, pastes or colorless ~ deep brown liquid.

Identification When Diastase is proceeded as directed under Activity Test, it should have the activity as Diastase.

Purity (1) Arsenic : It should be no more than 4.0 ppm tested by Arsenic Limit Test.

(2) Lead : When 5.0 g of Diastase is tested by Atomic Absorption Spectrophotometry or Inductively Coupled Plasma Emission Spectroscopy, its content should not be more than 5.0 ppm.

(3) Coliform Group : Diastase is tested by Microbe Test Methods for Coliform Group in General Test Methods in 「Standards and Specifications for Foods」. It should contain 30 colonies or less per 1 g of this product.

(4) Salmonella : Diastase is tested by Microbe Test Methods for Salmonella in General Test Methods in 「Standards and Specifications for Foods」. It should be negative (-).

(5) E. Coli : When Diastase is tested by Microbe Test Methods for E. Coli in General Test Method 「Standards and Specifications for Foods」, it should be negative (-).

Activity Test (Activity)

Analysis Principle : This test is to measure the activity of amylase in malt and other enzymes. Activity test is based on hydrolysis of starch substrate for 30 minutes at 20°C and pH 4.6. Reducing sugar obtained by hydrolysis is tested by the titration with alkaline ferricyanide.

Preparation of Test Solution

- Malt sample : 30 g of sample is finely ground with a mill. 25 g of the ground powder is accurately weighed into a 1,000 mL Erlenmeyer flask, which is leached in 500 mL of 0.5% sodium chloride solution for 2.5 hours at $20 \pm 0.2^\circ\text{C}$ while gently shaking in a 20 minute interval (note : The flask should not be turned up side down. The amount of sample left on the inner wall of the flask should be minimized.) It is then filtered through a Whatman No.1 filter paper or equivalent on a 32 cm diameter funnel. First 50 mL of the filtrate is added back to the funnel and filtered again. To prevent evaporation during filtering, a watchglass is placed on top of the funnel and other opening (necks and mouth of receiving container) is covered appropriately. Filtrate is collected exactly for 30 minutes. 20 mL of the filtrate is diluted to 100 mL with 0.5% sodium chloride solution (Test Solution).
- Other Enzymes : The final diluted solution is prepared so that it contains Diastatic power(DP) value 2~150°C per 10 mL.
- Test Procedure : 10 mL of Test Solution is accurately taken into a 250 mL volumetric flask, where 200 mL of substrate solution (isothermalized for 30 minutes at $20 \pm 0.2^\circ\text{C}$ prior to use) and time is recorded. The flask is cooled for 30 minutes in a water bath at 20°C. 20 mL of 0.5 N sodium hydroxide solution

and water are added to bring the volume to 250 mL. 5 mL of the resultant solution is taken into a 125 mL Erlenmeyer flask, added 10 mL of alkaline ferricyanide solution, and mixed. This is heated exactly for 20 minutes in a boiling water bath. After cooling to room temperature, 25 mL of A.P.Z. solution, 1 mL of potassium iodide solution, and 2 mL of starch TS are added to the flask, which is then titrated with 0.05 N sodium thiosulfate solution until the blue color disappears completely (consumed amount in mL of sodium thiosulfate solution, S). Separately, blank test solution is prepared in a 250 mL volumetric flask with 20 mL of 0.5 N sodium hydroxide solution, 10 mL of Test Solution, 200 mL substrate solution, and water (total volume 250 mL) by following the same procedure. The consumed amount in mL of sodium thiosulfate solution for blank test is B.

Activity of diastase as expressed as DP°C is obtained using the following equations.

$$\text{DP}^\circ\text{C}(\text{as a base material}) = (B-S) \times 23 \times \frac{F}{100}$$

$$\text{DP}^\circ\text{C}(\text{dried form}) = \text{DP}^\circ\text{C}(\text{as a base material}) \times \frac{100}{(100-M)}$$

23 : Conversion factor to a defined unit

M : Water Content (%)

F : Dilution Factor (Total Dilution/Weight of sample(g))

- Definition of Activity : 1 Diastase activity unit expressed as DP°C (degrees of diastatic power) corresponds to an amount of enzymes contained in 0.1 mL of 5% solution of Test Solution which produces sufficient amount of reducing sugar that can reduce 5 mL of Fehling solution when 100 mL of substrate is processed for 1 hour at 20°C.

Apparatus

Mill : Laboratory mill is used.

Solutions

- Acetate Buffer Solutions : 68 g of sodium acetate is dissolved in 500 mL of 1N acetic acid. Water is added to bring the total volume to 1,000 mL.
- Starch : A starch that is specified in α -amylase(non microbial) is used.
- Substrate Solution : 20 g of starch (as dried form) is dispersed in 50 mL of water, and added slowly to 750 mL of boiling water. It is then boiled for 2 minutes. After cooling, it is mixed with 20 mL of acetate buffer solution. The total volume is brought up to 1,000 mL with water.
- Acetic Acid-Potassium Chloride-Zinc Sulfate Solution (A.P.Z.) : 70 g of potassium chloride and 20 g of zinc sulfate ($\text{ZnSO}_4 \cdot 7\text{H}_2\text{O}$) are dissolved in 700 mL of water, where 200 mL of glacial acetic acid is added. The total

volume is brought up to 1,000 mL with water.

- 0.05 N alkaline ferricyanide solution : 16.5 g of potassium ferricyanide ($K_3Fe(CN)_6$) and 22 g of sodium carbonate are dissolved in 800 mL of water. Water is added to bring the total volume to 1,000 mL.
- Potassium iodide solution : 50 g of potassium iodide is dissolved in 50 mL of water and diluted to 100 mL, where 2 drops of 50% sodium hydroxide solution are added. This solution should be colorless

Storage Standard of Diastase

Diastase should be stored in a hermetic container in a cold dark place.

Diatomaceous Earth

Synonyms: Diatomite

CAS No.: 61790-53-2

Definition Diatomaceous Earth is silicon dioxide originated from diatom. There are three types, dried, calcined, and flux-calcined. These will be named as diatomaceous earth (dried), diatomaceous earth (calcined), and diatomaceous earth (flux-calcined). Calcined diatomaceous earth is calcined at 800~1,200°C. Flux-calcined diatomaceous earth is calcined at 800~1,200°C with a small amount of alkali carbonates. If flux-calcined diatomaceous earth is washed with acid, specifications for calcined form are applied (except for characteristics).

Compositional Specifications of Diatomaceous Earth

Description Dried material is milky white to pale gray powder, calcined material is reddish~pale brown powder, and flux-calcined material is white to pale reddish brown powder.

Identification (1) 0.2 g of Diatomaceous Earth is dissolved in 5 mL of hydrofluoric acid in a platinum crucible. When the solution is heated, almost all of it evaporates.

(2) When examined with 100x to 200x microscope, typical diatom shapes are observed.

Purity (1) Water Solubles substances and pH : 10 g of Diatomaceous Earth is added to 100 mL of water. It is then boiled for 2 hours in a water bath, supplementing water with occasionally shaking. After cooling, it is filtered with a suction-filtering apparatus that is equipped with a 47 mm diameter membrane filter (pore size 0.45 μm). If the filtrate is turbid, it is filtered again through the same filter. The residue on filter paper is washed with water and wash water is added to the previous filtrate. The total volume is make to 100 mL with water. Using a glass electrode, pH of the resulting filtrate is measured. pH should be 5.0~10.0 for dried or calcined material and 8.0~11.0 for flux-calcined material. 50 mL of the filtrate is evaporated to dryness and the residue is further dried for 2 hours at 105°C. The amount of water solubles should not be more than 15 mg, 10 mg, and 25 mg for dried, calcined, and flux-calcined material, respectively (should not be more than 0.3%, 0.2%, 0.5% for dried, calcined, and flux-calcined material, respectively).

(2) Hydrochloric acid soluble substances : 50 mL of diluted hydrochloric acid is added to 5 g of Diatomaceous Earth, which is shaken for 15 minutes at 50°C. It is then heated for 1 hour in a water bath, supplementing water with occasionally shaking. After cooling, it is filtered. The residue on filter paper is washed with water and wash water is added to the filtrate. The total volume is make to 100 mL with water and use the Solution A. 1 mL of diluted sulfuric acid (1→20) is added to 10 mL of Solution A, which is evaporated to dryness and further dried at 550°C until the weight becomes constant. The amount of residue should not be more than 15 mg (should not be more than 3%).

(3) Arsenic : It should be no more than 10.0 ppm tested by Arsenic Limit Test with 2 mL of A solution of Purity (2).

(4) Lead : When solution A as test solution in Purity (2) is tested by Atomic Absorption

Spectrophotometry or Inductively Coupled Plasma Emission Spectroscopy, its content should not be more than 10.0 ppm.

Loss on Ignition When Diatomaceous Earth is dried at 105°C for 2 hours and heat treated at 1,000°C for 30 minutes, the weight loss should not be more than 7.0% for dried material and should not be more than 2.0% for calcined, and flux-calcined material.

Hydrofluoric Acid Residue A platinum crucible is previously ignited for 30 minutes at 1,000°C. 0.2 g of Diatomaceous Earth is accurately weighed in a crucible, where 5 mL of hydrofluoric acid and 2 drops of diluted sulfuric acid (1→2) are added, which is evaporated to approximate dryness on a water bath. It is then heat treated for 1 hour at 550°C and gradually further heated to 1,000°C kept temperature for 30 minutes. It is then cooled in a desiccator and weighed accurately. The amount of residue should not be more than 50 mg (not more than 25%).

Dibenzoyl Thiamine



Chemical Formula: $C_{26}H_{26}O_4N_4S$

Molecular Weight: 490.59

CAS No.: 299-88-7

Compositional Specifications of Dibenzoyl Thiamine

Content Dibenzoyl Thiamine, when calculated on the dried basis, should contain not less than 97.0% of dibenzoyl thiamine ($C_{26}H_{26}N_4O_4S$).

Description Dibenzoyl Thiamine is a white crystalline powder without scent.

Identification (1) To 5 mg of Dibenzoyl Thiamine, add 1 mL of methanol, and dissolve while warming. Add 2 mL of water, 2 mL of cysteine hydrochloride solution (1→100), and 2 mL of phosphate buffer (pH 7), and shake and allow to stand for 30 minutes. Add 1 mL of freshly prepared potassium ferricyanide solution, 5 mL of 0.5 N sodium hydroxide solution, and 5 mL of n-butyl alcohol, shake vigorously for 2 minutes, and allow to stand to form two layers. Expose to ultraviolet light from above, and observe the top of the upper-layer solution from a direction perpendicular to the direction of irradiation. A blue-purple fluorescence is observed. This fluorescence disappears when the solution is made acidic, and reappears when it is made alkaline.

(2) To 30 mg of Dibenzoyl Thiamine, add 7 mL of diluted 0.1 N hydrochloric acid, and dissolve by heating in a water bath. Add 2 mL of mixture of hydroxylamine hydrochloride solution (3→20) · sodium hydroxide solution (3→20)(1:1), and shake for 1 minute. 0.8 mL of hydrochloric acid and 0.5 mL of ferric chloride solution is added, a purple color develops.

Purity (1) Melting Point : Melting point of Dibenzoyl Thiamine should be within a range of 163 ~ 174°C.

(2) Chloride : Dissolve 0.4 g of Dibenzoyl Thiamine in 20 mL of methanol, add 6 mL of diluted nitric acid, add water to make 50 mL, and add 1 mL of silver nitrate solution. The turbidity of this solution should be lower than that of a solution prepared by the following procedure. To 0.6 mL of 0.01 N hydrochloric acid, add 20 mL of methanol, 6 mL of diluted nitric acid and water to make 50 mL, where 1 mL of silver nitrate solution is added.

(3) Lead : When 5.0 g of Dibenzoyl Thiamine is tested by Atomic Absorption Spectrophotometry or Inductively Coupled Plasma Emission Spectroscopy, its content should not be more than 2.0 ppm.

Loss on Drying When Dibenzoyl Thiamine is dried for 2 hours at 105°C, the weight loss should not be more than 3%.

Residue on Ignition When thermogravimetric analysis is done with Dibenzoyl Thiamine, the residue should not be more than 0.2%.

Assay Accurately weigh about 0.4 g of Dibenzoyl Thiamine, previously dried, dissolve in 40 mL of methanol and 40 mL of 0.1N hydrochloric acid, and add water to make 1,000 mL. Take 5 mL of this solution, add 0.1 N hydrochloric acid to make 250 mL. Measure absorbance A of this solution at a wavelength of 237 nm. Separately, a blank test is carried out by the same procedure and absorbance A_0 is measured. The content is calculated by the following equation:

$$\text{Content(\%)} = \frac{A - A_0}{\text{weight of the sample(mg)}} \times \frac{400}{0.452} \times 100$$

Dibenzoyl Thiamine Hydrochloride

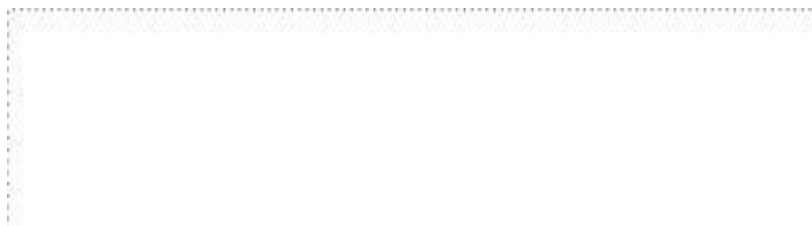

Chemical Formula: $C_{26}H_{26}O_4N_4S \cdot HCl \cdot 3H_2O$

Molecular Weight: 581.10

CAS No.: 35660-60-7

Compositional Specifications of Dibenzoyl Thiamine Hydrochloride

Content Dibenzoyl Thiamine Hydrochloride, when calculated on the dried basis, should contain not less than 97.0% of dibenzoyl thiamine hydrochloride ($C_{26}H_{26}O_4N_4S \cdot HCl = 527.06$).

Description Dibenzoyl Thiamine Hydrochloride occurs as a white crystalline powder. It is odorless.

Identification (1) Dissolve 0.1 g of Dibenzoyl Thiamine Hydrochloride in 10 mL of methanol, add 1 mL of dilute nitric acid and 1 mL of silver nitrate solution, white precipitate is produced.

(2) Proceed as directed under Identification in 「Dibenzoyl Thiamine」.

Purity (1) Clarity and Color of Solution : When 1 g of Dibenzoyl Thiamine Hydrochloride is dissolved in 10 mL of water by heating in a water bath, the solution should not be more than almost clear.

(2) Lead : When 5.0 g of Dibenzoyl Thiamine Hydrochloride is tested by Atomic Absorption Spectrophotometry or Inductively Coupled Plasma Emission Spectroscopy, its content should not be more than 2.0 ppm.

Loss on Drying When Dibenzoyl Thiamine Hydrochloride is dried for 24 hours in a vacuum desiccator (silica gel), the weight loss should not be more than 11%.

Residue on Ignition When thermogravimetric analysis is done with Dibenzoyl Thiamine Hydrochloride, the amount of residue should not be more than 0.2%.

Assay 0.4 g of Dibenzoyl Thiamine Hydrochloride, previously dried and accurately weigh, proceed as directed under Assay in 「Dibenzoyl Thiamine」.

$$\text{Content(\%)} = \frac{A - A_0}{\text{weight of the sample(mg)}} \times \frac{400}{0.421} \times 100$$

Diluted Benzoyl Peroxide

Chemical Formula: $C_{14}H_{10}O_4$

Molecular Weight: 242.23

INS No.: 928

Synonyms: Benzoyl superoxide

CAS No.: 94-36-0

Definition Diluted Benzoyl Peroxide is benzoyl peroxide ($C_{14}H_{10}O_4$) diluted with one or more of the following : Aluminum Potassium Sulfate, calcium salts of phosphate, Calcium Sulfate. Calcium Carbonate, Magnesium Carbonate, and starch.

Compositional Specifications of Diluted Benzoyl Peroxide

Content Diluted Benzoyl Peroxide should contain within a range of 19.0 ~ 22.0% of Benzoyl peroxide ($C_{14}H_{10}O_4=242.23$)

Description Diluted Benzoyl Peroxide occurs as a white powder.

Identification Transfer 0.2 g of Diluted Benzoyl Peroxide into test tube, add 7 mL of chloroform and mix by shaking and settled. White insoluble substances are observed. When 2 mL of 4,4'-diaminophenylamine solution is added, the solution and the insoluble substances turn bluish green.

Purity (1) Fineness : Transfer 5 g of Diluted Benzoyl Peroxide into a dried 53 μ standard sieve and sieved vigorously for 2 minutes, while occasionally tapping the bottom of the receiving container. Fine particles are settled for 1 minute and the residues on the screen is weighed. The amount of the residues should not be more than 1 g.

(2) Spread of Fire : 1 g of Diluted Benzoyl Peroxide is packed (3 mm height and 10 mm width) on a glass plate and ignited from one end. It should not be ignited all the way to the other end.

(3) Hydrochloric Acid Insoluble Substances : To 0.2 g of Diluted Benzoyl Peroxide, add 10 mL of dilute hydrochloric acid. It is well mixed by shaking, heated for approximately for 1 minute, and cooled. Approximately 8 mL of ether is added and shaken. When it is settled, both liquid layers should be clear. There should not be any definite floating matters in the interface.

(4) pH : To 3 g of Diluted Benzoyl Peroxide, add 30 mL of water and shaking for 3 minutes. It is then filtered and the pH of the filtrate is measured. The pH should be within a range of 6.0~9.0.

(5) Ammonium Salt : When 0.2 g of Diluted Benzoyl Peroxide is boiled in 3 mL of sodium hydroxide solution (2→5), the gas generated should not turn a red litmus paper wetted with water blue .

(6) Arsenic : It should be no more than 4.0 ppm tested by Arsenic Limit Test.

(7) Lead : When 5.0 g of Diluted Benzoyl Peroxide is tested by Atomic Absorption Spectrophotometry or Inductively Coupled Plasma Emission Spectroscopy, its content should not be more than 2.0 ppm.

(8) Barium : 2 g of Diluted Benzoyl Peroxide is mixed with 15 mL of dilute nitric acid by shaking, which is filtered. The residues are washed with water and the wash water is added to the filtrate. Water is added to the filtrate to bring the total volume to 40 mL. pH of the resulting solution is adjusted to

2.4~2.8 with ammonia solution, where water is added to bring the total volume to 50 mL. When 1 mL of dilute sulfuric acid is added to this solution and set aside for 10 minutes, it should not turn turbid.

Assay Transfer about 1 g of Diluted Benzoyl Peroxide, accurately weigh, into a flask with a ground-glass stopper, add 50 mL of chloroform-methanol mixture (1:1), and shake. Add 0.5 mL of a solution of citric acid in methanol (1→10) and 2 mL of potassium iodide solution (1→2), immediately stopper tightly, allow to stand in a dark place for 20 minutes while shaking occasionally, and titrate the liberated iodine with 0.1 N sodium thiosulfate (indicator : starch TS). Separately, perform a blank test in the same manner.

1 mL of 0.1 N sodium thiosulfate = 12.11 mg of $C_{14}H_{10}O_4$

Disodium 5'-Cytidylate



Chemical Formula: $C_9H_{12}N_3Na_2O_8P$

Molecular Weight: 367.16

CAS No.: 6757-06-8

Compositional Specifications of Disodium 5'-Cytidylate

Content When Disodium 5'-Cytidylate, when calculated on the dried basis, should contain within a range of 97.0 ~ 102.0% of disodium 5'-cytidylate ($C_9H_{12}N_3Na_2O_8P$).

Description Disodium 5'-Cytidylate occurs as colorless to white crystals or as a white crystalline powder, having a slight, characteristic taste.

Identification (1) Dissolve 20 mg of Disodium 5'-Cytidylate in 100 mL of 0.01N hydrochloric acid (1→1,000) and 0.01 N hydrochloric acid is added to 10 mL of this solution to make 100 mL. The solution exhibits an absorption maximum at a wavelength of 279 ± 2 nm.

(2) To 3 mL of Disodium 5'-Cytidylate solution (3→10,000), add 1 mL of hydrochloric acid and 1 mL of bromine solution, heat in a water bath for 30 minutes, remove the bromine by blowing with air, add 0.2 mL of a solution of orcinol in ethanol (1→10), then add 3 mL of a solution of ferric ammonium sulfate in diluted hydrochloric acid (1→1,000), and heat in a water bath for 20 minutes. A green color becomes.

(3) To 5 mL of Disodium 5'-Cytidylate solution (1→20), add 2 mL of magnesia solution. No precipitate is formed. Then, add 7 mL of nitric acid, boil for 10 minutes and neutralize with sodium hydroxide solution (1→25). The solution responds to the test for Phosphate (2).

(4) Disodium 5'-Cytidylate responds to test of Sodium Salts in Identification.

Purity (1) Clarity and Color of Solution : When 0.5 g of Disodium 5'-Cytidylate is dissolved in 10 mL of water, the solution should be colorless and almost clear.

(2) pH : pH of Disodium 5'-Cytidylate solution (1→20) should be within a range of 8.0 ~ 9.5 as determined by glass electrode method.

(3) Arsenic : It should be no more than 4.0 ppm tested by Arsenic Limit Test.

(4) Lead : Disodium 5'-Cytidylate is tested by Purity (2) for Sodium Metaphosphate (not more than 2.0

ppm).

(5) Absorption Ratio : Measure absorbances A1, A2, and A3 of 0.01N hydrochloric acid solution of Disodium 5'-Cytidylate(1→50,000) at wavelengths of 250 nm, 260 nm, and 280 nm, respectively. A1/A2 is 0.40 ~ 0.52, and A3/A2 is 1.85 ~ 2.20.

(6) Other decomposed substances of ribonucleic acids : Proceed as directed under Purity (6) for [5-Disodium Guanylate]

Water Content Water content of approximately 0.15 g of Disodium 5'-Cytidylate as determined by water content determination method should not be more than 26.0%. In this case, sample transfer into a dried titration flask, where 10 mL of Karl-Fisher methyl alcohol is added. A certain amount of Karl-Fisher solution is added so that there is an excess of approximately 10 mL. Then the flask is capped and shaken for 20 minutes. It is titrated with water-methyl alcohol standard solution. Separately, a blank test is carried out by following the same procedure.

Assay Accurately weigh about 500 mg of Disodium 5'-Cytidylate, and dissolve in 0.01 N hydrochloric acid to make exactly 1,000 mL. Measure 10 mL of this solution, and add 0.01 N hydrochloric acid to make exactly 250 mL. Use this solution as the test solution. With reference solution, 0.01N hydrochloric acid, measure absorbance A of the test solution at a wavelength of 280 nm, and calculate the content by the following formula

Content of disodium 5'-cytidylate (C₉H₁₂N₃Na₂O₈P) (%)

$$= \frac{500}{\text{weight of the sample(mg)}} \times \frac{144.6 \times A}{100 - \text{water content(\%)}} \times 100$$

Disodium Dihydrogen Pyrophosphate

Chemical Formula: $\text{Na}_2\text{H}_2\text{P}_2\text{O}_7$

Molecular Weight: 221.94

INS No.: 450(i)

Synonyms: Disodium dihydrogen diphosphate;

Disodium diphosphate; Sodium acid
pyrophosphate

CAS No.: 7758-16-9

Compositional Specifications of Disodium Dihydrogen Pyrophosphate

Content Disodium Dihydrogen Pyrophosphate, when calculated on the dried basis, should contain not less than 95.0% of disodium dihydrogen pyrophosphate ($\text{Na}_2\text{H}_2\text{P}_2\text{O}_7$).

Description Disodium Dihydrogen Pyrophosphate occurs as a white crystalline powder or granular.

Identification (1) To 10 mL of Disodium Dihydrogen Pyrophosphate solution (1→100), add 1 mL of silver nitrate solution. A white precipitate is formed.

(2) Disodium Dihydrogen Pyrophosphate responds to the test for Sodium Salt in Identification.

Purity (1) Water Insoluble Substances : 5 g of Disodium Dihydrogen Pyrophosphate, accurately weighed, dissolve in 100 mL of hot water. Insoluble substances are separated by a glass filter (1G4) and washed with 30 mL of hot water. The glass filter is dried for 2 hours at 105°C. The amount of insoluble substances should not be more than 1.0%.

(2) pH : pH of Disodium Dihydrogen Pyrophosphate solution (1→100) should be within a range of 3.7 ~ 5.0.

(3) Arsenic : It should be no more than 4.0 ppm tested by Arsenic Limit Test.

(4) Lead : Disodium Dihydrogen Pyrophosphate is tested by purity (2) for 「Sodium Metaphosphate」(not more than 4.0 ppm).

(5) Cadmium : Disodium Dihydrogen Pyrophosphate and is tested by purity (3) for 「Sodium Metaphosphate」(not more than 1.0 ppm).

(6) Mercury : When Disodium Dihydrogen Pyrophosphate is tested by Mercury Limit Test, its content should not be more than 1.0 ppm.

(7) Fluoride : 1 g of Disodium Dihydrogen Pyrophosphate, precisely weighed, ~~and~~ is tested by purity (8) for 「Calcium Citrate」(not more than 10 ppm).

Loss on Drying When Disodium Dihydrogen Pyrophosphate is dried for 4 hours at 110°C, the weight loss should not be more than 5%.

Assay 400 mg of Disodium Dihydrogen Pyrophosphate, previously dried for 4 hours at 105°C and accurately weighed, is dissolved in 100 mL of water. Its pH is adjusted 3.8, using a pH meter with hydrochloric acid. To this solution, 50 mL of zinc sulfate solution (1→8) [125 g of zinc sulfate (hepta

hydrated) is dissolved in water to have a total volume of 1,000 mL and its pH is adjusted to 3.8] is added. After 2 minutes, free acid is titrated with 0.1 N sodium hydroxide solution until pH becomes 3.8. Near the end point, the solution should be set-aside so that precipitated zinc hydroxide gets dissolved again.

1 mL of 0.1 N sodium hydroxide solution = 11.10 mg $\text{Na}_2\text{H}_2\text{P}_2\text{O}_7$

Disodium Ethylenediaminetetraacetate

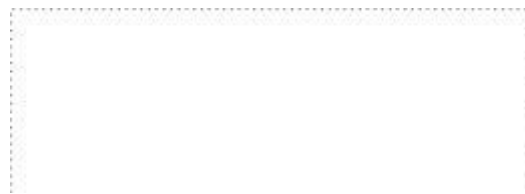

Chemical Formula: $C_{10}H_{14}N_2Na_2O_8 \cdot 2H_2O$

Molecular Weight: 372.24

INS No.: 386

Synonyms: Disodium edetate; Disodium EDTA

CAS No.: 139-33-3

Compositional Specifications of Disodium Ethylenediaminetetraacetate

Content Disodium Ethylenediaminetetraacetate should contain not less than 99.0% of disodium ethylenediaminetetraacetate ($C_{10}H_{14}N_2Na_2O_8 \cdot 2H_2O$).

Description Disodium Ethylenediaminetetraacetate occurs as a whitish crystalline powder. It is odorless.

Identification (1) Disodium Ethylenediaminetetraacetate solution (1→20) responds to the test for Sodium Salt (B) of (1) in Identification.

(2) To pink color solution which is prepared by adding 5 mL of water, 2 drops of ammonium thiocyanate solution, and 2 drops of ferric chloride solution to a test tube, add approximately 50 mg of Disodium Ethylenediaminetetraacetate. Its red color disappears.

Purity (1) pH : pH of Disodium Ethylenediaminetetraacetate solution(1→100) should be within a range of 4.3 ~ 4.7.

(2) Arsenic : It should be no more than 4.0 ppm tested by Arsenic Limit Test.

(3) Lead : When 5.0 g of Disodium Ethylenediaminetetraacetate is tested by Atomic Absorption Spectrophotometry or Inductively Coupled Plasma Emission Spectroscopy, its content should not be more than 2.0 ppm.

(4) Cyanide : Transfer 1 g of Disodium Ethylenediaminetetraacetate into a round-bottom flask, dissolve in 100 mL of water, add 10 mL of phosphoric acid, and distilled. Use a 100 mL mass flask containing 15 mL of 0.5 N sodium hydroxide solution as the receiver, immerse the end of the condenser in it, and distill until the total amount becomes 100 mL. Use this solution as the test solution. 2 mL of test solution transfer into a test tube with a ground glass stopper, which is neutralized with dilute acetic acid using 1 drop of phenolphthalein solution. 5 mL of phosphate buffer solution (pH 6.8) and 1 mL of chloramine solution (1→5) are added to the solution and the stopper is placed. Mix gently, and allow to stand for 2 ~ 3 minutes. Add 5 mL of pyridine.pyrazolone solution, mix thoroughly, and allow to stand at 20 ~ 30°C for 50 minutes. The color of the solution should not be deeper than that of the

reference solution. To prepare Reference solution, measure 1 mL of cyanide standard solution, add 15 mL of 0.5 N sodium hydroxide solution and water to make 100 mL. The same procedure is repeated with 2 mL of the resulting solution in a test tube with a ground glass stopper.

Assay Accurately weigh about 0.4 g of Disodium Ethylenediaminetetraacetate, dissolve in 20 mL of water, add 10 mL of ammonia.ammonium chloride buffer (pH 10.7), and titrate with 0.05 M zinc chloride (indicator : 2 drops of Eriochrome black T solution) until the blue color of the solution changes to red.

1 mL of 0.05 M Zinc Chloride = 18.612 mg of $C_{10}H_{14}N_2Na_2O_8 \cdot 2H_2O$

Disodium Glycyrrhizinate



Chemical Formula: $C_{42}H_{60}Na_2O_{16}$

Molecular Weight: 866.92

CAS No.: 71277-79-7

Compositional Specifications of Disodium Glycyrrhizinate

Content Disodium Glycyrrhizinate, when calculated on the dried basis(anhydrous), should contain within a range of 95.0 ~ 102.0% of disodium glycyrrhizinate ($C_{42}H_{60}Na_2O_{16}$).

Description Disodium Glycyrrhizinate occurs as a white ~ light yellow powder with an extremely sweet taste.

Identification (1) To 0.5 g of Disodium Glycyrrhizinate, add 10 mL of 1 N hydrochloric acid. It is boiled gently for 10 minutes and filtered. The residue on the filter paper is washed with water thoroughly and dried at 105°C for 1 hour. To 1 mL of a solution of the dried substance in alcoholic solution (1→1,000), add 0.5 mL of a dibutyl hydroxytoluene solution in ethanol (1→100) and 1 mL of sodium hydroxide solution (1→5), which is then heated for 30 minutes in a water bath while evaporating the ethanol. Reddish purple ~ purple flocculent substances are formed in the residual solution.

(2) To 1 mL of the filtrate in (1), add 10 mg of naphthoresorcin and 5 drops of hydrochloric acid, and boiled gently for 1 minute, and allowed to stand for 5 minutes, and immediately cooled. To this solution, add 3 mL of benzene and shake. The color of the benzene layer changes to reddish purple.

(3) The residue on ignition of Disodium Glycyrrhizinate responds to the test for—Sodium Salt in Identification.

Purity (1) Clarity and Color of Solution : Dissolve 0.5 g of Disodium Glycyrrhizinate in 5 mL of water, it should not be more than clear and its color should not be deeper than that of the color standard solution I.

(2) pH : pH of Disodium Glycyrrhizinate solution (1→20) should be within a range of 5.5 ~ 6.5.

(3) Chloride : To 0.5 g of Disodium Glycyrrhizinate, add 6 mL of diluted nitric acid (1→10) and 10 mL of

water, and boil gently for 10 minutes, and filter. Residues on the filter paper are washed twice with a small amount of water and the washing water is combined with the filtrate. If the filtrate is colored, 1 mL of hydrogen peroxide is added and heated in a water bath for 10 minutes. After cooling, the precipitate is filtered and washed twice with a small amount of water. The filtrate and wash water is combined and tested by Chloride Limit Test. The content of chloride should not be higher than the amount that corresponds to 0.2 mL of 0.01 N hydrochloric acid.

(4) Sulfate : To 0.5 g of Disodium Glycyrrhizinate, add 5 mL of diluted hydrochloric acid (1→4) and 10 mL of water, and boil gently for 10 minutes and filter. The residue on the filter paper is washed twice with a small amount of water and the wash water is combined with the filtrate. The filtrate is neutralized with ammonia solution. If the filtrate is colored, 1 mL of hydrogen peroxide is added and heated in a water bath for 10 minutes. It is then cooled and filtered if necessary. The residue on the filter paper is washed twice with a small amount of water and wash water is combined with the filtrate, Test Solution. When Test Solution is tested by Sulfate Limit Test, the content should not be higher than the amount that corresponds to 0.3 mL of 0.01 N sulfuric acid

(5) Arsenic : It should be no more than 4.0 ppm tested by Arsenic Limit Test.

(6) Lead : Disodium Glycyrrhizinate is tested by Purity (2) for 「Sodium Metaphosphate」(not more than 2 ppm).

Water Content Accurately weigh about 0.2 g of Disodium Glycyrrhizinate, and tested by the back titration method in water content determination (Karl-Fischer Method). The water content should not be more than 13%.

Residue on Ignition When thermogravimetric analysis is done with 1 g of Disodium Glycyrrhizinate, the amount of residue should be within a range of 15 ~ 18% (calculated on the anhydrous basis).

Assay Accurately weigh about 100 mg of Disodium Glycyrrhizinate, and dissolve in water to make 1,000 mL. Take 10 mL of this solution, add water to make 25 mL, Test Solution. Separately, 50 mg of nicotinamide standard, previously dried in a vacuum desiccator (sulfuric acid) for 4 hours, and dissolved in water to make 1,000 mL. Take 10 mL of this solution, add water to make 25 mL, standard reference solution. Absorbance A of the test solution is measured at a wavelength of 259 nm, using water as a reference. Absorbance A_s of the standard reference solution at a wavelength of 261 nm is measured using water as a reference. The content of disodium glycyrrhizinate is calculated by the following equation

$$\text{Content (\%)} = \frac{2A}{A_s \times 1.0928} \times \frac{\text{Amount of nicotinamide(mg)}}{\text{weight of the sample(mg) — water content(mg)}} \times 100$$

Disodium 5'-Guanylate

Sodium 5'-Guanylate

Sodium Guanylate



Chemical Formula: $C_{10}H_{12}O_8N_5PNa_2$

Molecular Weight: 407.20

INS No.: 627

Synonyms: Sodium 5'-Guanylate; Sodium Guanylate

CAS No.: 5550-12-9

Compositional Specifications of Disodium 5'-Guanylate

Content Disodium 5'-Guanylate, when calculated on the dried basis, should contain within a range of 97.0 ~ 102.0% of disodium 5'-guanylate ($C_{10}H_{12}O_8N_5PNa_2$).

Description Disodium 5'-Guanylate occurs as colorless to white crystals, white crystalline powder or powder, having a characteristic taste.

Identification (1) 20 mg of Disodium 5'-Guanylate is dissolved in 100 mL of 0.01 N hydrochloric acid, 10 mL of which is diluted to 100 mL with 0.01 N hydrochloric acid. The resulting solution shows a maximum absorption band at 256 ± 2 nm.

(2) To 3 mL of aqueous solution of Disodium 5'-Guanylate (3→10,000), add 0.2 mL of alcoholic solution of (1→10) and 3 mL of ammonium ferrous sulfate (1→1,000), which is heated for 10 minutes in a water bath. The solution turns green.

(3) When add 2 mL of magnesia solution to 5 mL of Disodium 5'-Guanylate solution (1→100), precipitates are not formed. To the resulting solution, 7 mL of nitric acid is added and boiled for 10 minutes. When this solution is neutralized with sodium hydroxide solution, it responds to the test for ϕ phosphate (B) in Identification.

(4) Disodium 5'-Guanylate responds to the test for ϕ Sodium Salt in Identification.

Purity (1) Clarity and Color of Solution : When 0.1 g of Disodium 5'-Guanylate is dissolved in 10 mL of water, the solution should be colorless and almost clear.

(2) pH : pH of Disodium 5'-Guanylate solution (1→20) should be within a range of 7.0~8.5 as determined by the glass electrode method.

(3) Arsenic : It should be no more than 4.0 ppm tested by Arsenic Limit Test.

- (4) Lead : When 5.0 g of Disodium 5'-Guanylate is tested by Atomic Absorption Spectrophotometry or Inductively Coupled Plasma Emission Spectroscopy, its content should not be more than 1.0 ppm.
- (5) Absorption Ratio : Absorption (A_1 , A_2 , and A_3) of Disodium 5'-Guanylate in 0.01 N solution of hydrochloric acid (1→50,000) is measured at wavelengths of 250 nm, 260 nm, and 280 nm. Absorption ratios, A_1/A_2 and A_3/A_2 are 0.95 ~ 1.03 and 0.63 ~ 0.71, respectively.
- (6) Other Decomposed Substances : When thin plate chromatography is carried out with 1 μ l of aqueous solution of Disodium 5'-Guanylate (1→200) using a mixture of acetone, ammonia solution, and n-propyl alcohol (2 : 5 : 6) as a developing solvent, only one spot should be observed. In this case, silica gel for thin layer chromatography (with phosphor) that is dried for 1 hour at 110°C is used as a support material of thin layer. It is developed until the solvent front reaches approximately 10 cm from the starting point. It is then dried in air and observed under UV light (wavelength : approximately 250 nm) in a dark place. Reference solution is not used.

Loss on Drying When Disodium 5'-Guanylate is dried for 4 hours at 120°C, the weight loss should not be more than 25%.

Assay Dissolve about 500 mg of Disodium 5'-Guanylate, accurately weighed, in 0.01 N hydrochloric acid (Total volume = 1,000 mL). 10 mL of this solution is diluted to 250 mL with 0.01 N hydrochloric acid as Test Solution. Using 0.01 N hydrochloric acid as a reference solution, absorption A is measured at 260 nm with a path length of 1 cm. The content of Disodium 5'-Guanylate is obtained by the following equation

$$\text{Content(\%)} = \frac{A}{289.8} \times \frac{250,000}{\text{Weight of sample(mg)}} \times \frac{100}{100 - \text{loss on drying(\%)}} \times 100$$

Disodium 5'-Inosinate



Chemical Formula: $C_{10}H_{11}O_8N_4PNa_2 \cdot nH_2O$

Molecular Weight: anhydrous 392.17

INS No.: 631

Synonyms: Sodium 5'-inosinate; Sodium inosinate

CAS No.: 4691-65-0

Compositional Specifications of Disodium 5'-Inosinate

Content Disodium 5'-Inosinate, when calculated on the anhydrous basis, should contain within a range of 97.0 ~ 102.0% of disodium 5'-inosinate ($C_{10}H_{11}O_8N_4PNa_2$)

Description Disodium 5'-Inosinate occurs as colorless to white crystals or as a white crystalline powder, having a characteristic taste.

Identification (1) Dissolve 20 mg of Disodium 5'-Inosinate in 100 mL of 0.01 N hydrochloric acid. The solution exhibits an absorption maximum at a wavelength of 250 ± 2 nm.

(2) To 3 mL of Disodium 5'-Inosinate solution (3→10,000), add 0.2 mL of a solution of orcinol in alcohol(1→10), then add 3 mL of a solution of ferric ammonium sulfate in hydrochloric acid (1→1,000), and heat in a water bath for 10 minutes. A green color develops.

(3) To 5 mL of Disodium 5'-Inosinate solution (1→20), add 2 mL of magnesia solution. No precipitate is formed. Then, add 7 mL of nitric acid, boil for 10 minutes. and neutralize with sodium hydroxide solution. The solution responds to the test for Phosphate (B) in Identification.

(4) Disodium 5'-Inosinate responds to the test for Sodium Salt in Identification.

Purity (1) Clarity and Color of Solution : 0.5 g of Disodium 5'-Inosinate is dissolved in 10 mL of water. This solution should be Colorless and should not be more than almost clear.

(2) pH : pH of Disodium 5'-Inosinate solution (1→20) should be within a range of 7.0 ~ 8.5.

(3) Arsenic : It should be no more than 4.0 ppm tested by Arsenic Limit Test.

(4) Lead : When 5.0 g of Disodium 5'-Inosinate is tested by Atomic Absorption Spectrophotometry or Inductively Coupled Plasma Emission Spectroscopy, its content should not be more than 1.0 ppm.

(5) Absorption Ratio : Disodium 5'-Inosinate is dissolved in 0.01 N hydrochloric acid (1→50,000). Measure absorbances A1, A2, and A3 of this solution at wavelengths of 250 nm, 260 nm, and 280 nm,

respectively. A1/A2 should be 1.55 ~ 1.65, and A3/A2 should be 0.20 ~ 0.30.

(6) Other Decomposed Substances of Nucleic Acid : Use Disodium 5'-Inosinate solution (0.1→20), as the test solution. Measure 1 μ l of the test solution, perform Thin-Layer Chromatography without a reference solution, using n-propanol- ammonia solution- acetone mixture (6:5:2) as the developing solvent. Only one spot is observed. For the thin-layer plate, use a plate prepared by applying silica gel for thin-layer chromatography (fluorescent material coated) dried at 110°C for 1 hour as the support. Stop the development when the solvent front rises about 10 cm above the original line, air-drying in a dark place, and observe under ultraviolet light (wavelength : about 250 nm). Reference solution is not used.

Water Content When approximately 500 mg of Disodium 5'-Inosinate is tested for water content, it should not be more than 28.5%. In this case, sample is transferred into a dried titration flask, where 10 mL of Karl-Fischer methyl alcohol is added. Additionally Karl-Fischer methyl alcohol is added to have excess of 10 mL. It is then mixed by shaking with a cap for 20 minutes. It is titrated with water-ethyl alcohol standard solution. Separately, a blank test is carried out. Perform a blank test in the same manner.

Assay Accurately weigh about 500 mg of Disodium 5'-Inosinate, dissolve in 0.01 N hydrochloric acid to make 1,000 mL. Take 10 mL of this solution, and add 0.01 N hydrochloric acid to make 250 mL. Use this solution as the test solution. Use 0.01 N hydrochloric acid as the reference solution. Measure absorbance A of the test solution at a wavelength of 250 nm with 1 cm path length, and calculate the content by the following formula:

$$\text{Content(\%)} = \frac{A}{310} \times \frac{250,000}{\text{weight of the sample(mg)}} \times \frac{100}{100 - \text{water content(\%)}} \times 100$$

Disodium 5'-Ribonucleotide

Synonyms: Sodium ribonucleotides

INS No.: 635

Definition Disodium 5'-Ribonucleotide is a mixture of disodium 5'-inosinate, disodium 5'-guanylate, disodium 5'-cytidylate, and disodium 5'-uridylylate or a mixture of disodium 5'-inosinate and disodium 5'-guanylate.

Compositional Specifications of Disodium 5'-Ribonucleotide

Content Disodium 5'-Ribonucleotide, when calculated on the dried basis (anhydrous), should contain within a range of 97.0 ~ 102.0% of disodium 5'-ribonucleotide, not less than 95.0% of the disodium 5'-ribonucleotide consists of disodium 5'-inosinate and disodium 5'-guanylate.

Description Disodium 5'-Ribonucleotide occurs as white to milky white crystals or powder. It is odorless and has a characteristic taste.

Identification (1) To 1 mL of Disodium 5'-Ribonucleotide solution (1→2.000), add 0.2 mL of a solution of orcinol in ethanol (1→10), then add 3 mL of a solution of ferric ammonium sulfate in hydrochloric acid (1→1.000), and heat in a water bath for 10 minutes. A green color develops.

(2) To 5 mL of Disodium 5'-Ribonucleotide solution (1→20), add 2 mL of magnesia solution. No precipitate is formed. Add 7 mL of nitric acid, boil for 10 minutes, and neutralize with sodium hydroxide solution. The solution respond to the test for Phosphate (B).

(3) To 1 mL of Disodium 5'-Ribonucleotide solution (1→1.000), add 2 mL of diluted hydrochloric acid and 0.1 g of zinc dust, heat in a water bath for 10 minutes, filter, and cool the filtrate in ice water. Add 1 mL of sodium nitrite solution (3→1.000), shake, and allow to stand for 10 minutes. Add 1 mL of ammonium sulfamate solution (1→200), shake well, and allow to stand for 5 minutes. Add 1 mL N-1-naphthylethylene diamine dihydrochloride (1→500), a reddish purple color develops.

(4) To 1 mL of Disodium 5'-Ribonucleotide solution (1→5,000), add 1 mL of diluted hydrochloric acid, heat in a water bath for 10 minutes and cool. Add 0.5 mL of Folin's solution and 2 mL of sodium carbonate saturated solution, a blue color develops.

(5) 0.5 g of Disodium 5'-Ribonucleotide dissolve in 10 mL of the solution, which of 50 mL of hydroxylamine hydrochloride solution (7→50) adjusted to pH 6.5 by adding sodium hydroxide solution, and heat for 2 hours in a water bath. Take 1 mL of the solution is evaporated to dryness in a water bath. The residue is dissolved in 10 mL of water, which is cooled in an ice bat. Add 2 mL of sulfanilic acid diluted with hydrochloric acid (1→100) and mix by shaking, where 1 mL of sodium nitrite solution (1→4) is drop-wise added and allowed to stand for 10 minutes. When 2 mL of sodium hydroxide solution (2→5) is added to the solution, it becomes to orange red color.

(6) Disodium 5'-Ribonucleotide solution (1→10) responds to the test for Sodium Salt in Identification.

Purity (1) pH : A solution of Disodium 5'-Ribonucleotide (1→20) is tested by a glass electrode method. It should be within a range of 7.0 ~ 8.5.

(2) Arsenic : It should be no more than 4.0 ppm tested by Arsenic Limit Test.

(3) Lead : When 5.0 g of Disodium 5'-Ribonucleotide is tested by Atomic Absorption Spectrophotometry or Inductively Coupled Plasma Emission Spectroscopy, its content should not be more than 1.0 ppm.

Water Content When 150 mg of Disodium 5'-Ribonucleotide, precisely weighed, is tested by the back titration method in water content determination (Karl-Fischer Method), the water content should not be more than 27%. However, titration is carried out by the following procedure. Disodium 5'-Ribonucleotide is transferred into dried titration flask, where 10 mL of methanol (for Karl-Fischer) is added and Karl-Fischer solution (approximately 10 mL excess) is added. It is sealed and stir-mixed for 20 minutes. It is titrated with water-methyl alcohol standard solution while stirring vigorously. Separately, a blank test is carried out.

Assay The content of disodium 5'-ribonucleotide and that of disodium 5'-inosinate ($C_{10}H_{11}N_4Na_2O_8P$) and disodium 5'-guanylate ($C_{10}H_{11}N_4Na_2O_8P$) calculate from the values for I, G, and P obtained in (1), (2), and (3) below by the following formulas

$$\text{Content of Disodium 5'-Ribonucleotide(\%)} = \frac{I + G + P}{100 - \text{water}(\%)} \times 100$$

$$\begin{aligned} \text{Content of Disodium 5'-Inosinate} & (\text{C}_{10}\text{H}_{11}\text{N}_4\text{Na}_2\text{O}_8\text{P}) \\ \text{and 5'-Disodium Guanylate} & (\text{C}_{10}\text{H}_{12}\text{N}_5\text{Na}_2\text{O}_8\text{P})(\%) \end{aligned} = \frac{I + G}{100 - \text{water}(\%)} \times 100$$

(1) Disodium 5'-Inosinate : Accurately weigh about 650 mg of Disodium 5'-Ribonucleotide, dissolve in water to make 500 mL, and this solution is referred to as A solution. To 1 mL of A solution, add 4 mL of 6 N hydrochloric acid and water to make 10 mL, heat in a water bath for 40 minutes, cool, add 0.4 g of zinc powder, allow to stand for 50 minutes while vigorously shaking occasionally, add water to make 20 mL, and filter. To 10 mL of the filtrate, add 1 mL of 6 N hydrochloric acid (1→2), add 1 mL of sodium nitrite solution (3→1,000) while cooling in ice, shake well, and allow to stand for 10 minutes. Add 1 mL of ammonium sulfamate solution (1→200), shake well, and allow to stand for 5 minutes. To this solution, add 1 mL of N-1-naphthylethylenediamine dihydrochloride solution (1→500), shake well, allow to stand for 15 minutes, and add water to make 20 mL. Use this solution as the test solution. Separately, prepare the reference solution in the same manner as the test solution, using 1 mL of water in place of the A solution, and measure the absorbance of the test solution at a wavelength of 515 nm using the reference solution. Separately, accurately weigh each 3 mg of disodium 5'-inosinate and 3 mg of disodium 5'-guanylate, dissolve in 100 mL of 0.01 N hydrochloric acid, reference solution use 0.01 N hydrochloric acid, and measure the absorbances of both solutions. Determine at a wavelength of 250 nm for disodium 5'-inosinate and a wavelength of 260 nm for disodium 5'-guanylate. Calculate the molecular extinction coefficients E_I and E_G from the absorbances obtained, and calculate the contents of disodium 5'-inosinate and disodium 5'-guanylate, respectively, by the following formulas

$$\text{Contents of disodium 5'-inosinate} \\ (\text{C}_{10}\text{H}_{11}\text{N}_4\text{Na}_2\text{O}_8\text{P})(\%) = \frac{E_I}{12,160} \times 100$$

$$\text{Contents of 5'-disodium guanylate} \\ (\text{C}_{10}\text{H}_{12}\text{N}_5\text{Na}_2\text{O}_8\text{P})(\%) = \frac{E_G}{11,800} \times 100$$

Based on the contents above, accurately weigh corresponding amount to about 50 mg of each, combine them, and dissolve in water to make 200 mL. This is referred to as B solution. Take 1 mL, 2 mL, and 3 mL of the B solution, add 4 mL of 6 N hydrochloric acid and water to make 10 mL each, and prepare the standard solution in the same manner as the sample solution. Using the same reference solution as in the case of the test solution, measure the absorbance of each solution at a wavelength of 515 nm, and prepare a calibration curve. From the calibration curve and the absorbance of the test solution, calculate the content I (%) of disodium 5'-inosinate in the test solution.

(2) Disodium 5'-Guanylate : To 1 mL of the A solution in Assay (1), add 4 mL of 2N hydrochloric acid and water to make 10 mL, heat in a water bath for 30 minutes, cool, add 2 mL of Folin's solution and 5 mL of sodium carbonate solution (4→5), allow to stand for 15 minutes, add water to make 50 mL, and centrifuge if necessary. Use the supernatant as the test solution.

Separately, prepare the reference solution in the same manner as the test solution using 1 mL of water in place of the sample solution, and determine the absorbance of the test solution at a wavelength of 750 nm using the reference solution. Take 1 mL, 2 mL, and 3 mL of the B solution in Assay (1), add 4 mL of 2 N hydrochloric acid and water to make 10 mL each, and prepare the standard solution, using these 3 solutions in the same manner as the A solution. Measure the respective absorbances at a wavelength of 750 nm, using the same reference solution as for the test solution, and prepare a calibration curve. From the calibration curve and absorbance of the test solution, calculate the content G (%) of disodium 5'-guanylate ($\text{C}_{10}\text{H}_{11}\text{N}_4\text{Na}_2\text{O}_8\text{P}$) in the test solution.

(3) Disodium 5'-Cytidylate and Disodium 5'-Uridylate : Accurately weigh about 1.5 g of Disodium 5-Ribonucleotide, add water to make exactly 50 mL, and this solution is referred to as C solution. To 1 mL of the sample solution, add 2 mL of hydrazine (hydrate), heat in a water bath for 1 hour, cool, add 1 N hydrochloric acid to make the solution slightly acidic, and add 0.01 N hydrochloric acid to make exactly 100 mL. Measure exactly 10 mL of this solution, add 0.01 N hydrochloric acid to make exactly 100 mL, and use this solution as the test solution. Prepare the reference solution in the same manner as the test solution, using 1 mL of water in place of the C solution, and determine absorbances A_{260} and A_{280} of the test solution at wavelengths of 260 nm and 280 nm, respectively.

To 1 mL of the sample solution, add 0.01 N hydrochloric acid to make 100 mL, and measure 10 mL of this solution, and add 0.01 N hydrochloric acid to make 100 mL. Determine absorbances A'_{260} and A'_{280} of this solution at wavelengths of 260 nm and 280 nm, respectively, and calculate the content P (%) of disodium 5'-cytidylate ($\text{C}_9\text{H}_{12}\text{N}_3\text{Na}_2\text{O}_8\text{P}$) and disodium 5'-uridylate ($\text{C}_9\text{H}_{11}\text{N}_2\text{O}_8\text{P}$) in the sample

by the following formula.

$$P(\%) = \frac{170.5 \times (A'_{260} - A_{260}) + 68.6 \times (A'_{280} - A_{280})}{\text{weight of the sample(g)}}$$

Disodium Succinate

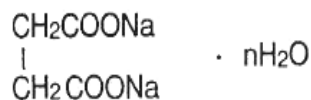

Chemical Formula: $\text{C}_4\text{H}_4\text{O}_4\text{Na}_2 \cdot 6\text{H}_2\text{O}$

Molecular Weight: 270.15

INS No.: 364(ii)

Synonyms: Butanedioic acid disodium salt

CAS No.: 150-90-3

Compositional Specifications of Disodium Succinate

Content Disodium Succinate, when calculated on the dried basis, should contain within a range of 98.0 ~ 101.0% of disodium succinate ($\text{C}_4\text{H}_4\text{O}_4\text{Na}_2 = 162.08$).

Description Disodium Succinate occurs as colorless to white crystals or as a white crystalline powder. It is odorless and has a characteristic taste.

Identification (1) Disodium Succinate responds to the test for Succinic Acid salt in Identification.

(2) Disodium Succinate responds to the test for Sodium Salt in Identification.

Purity (1) pH : pH of Disodium Succinate solution (1→20) should be within a range of 7.0 ~ 9.0.

(2) Sulfate : Weigh 1 g of Disodium Succinate, dissolve in 30 mL of water and neutralize with 1 % hydrochloric acid. Add 1 mL of dilute hydrochloric acid, Test Solution. The test Solution is tested by Sulfate Limit Test. Its content should not be more than the amount that corresponds to 0.4 mL of 0.01 N sulfuric acid.

(3) Arsenic : It should be no more than 4.0 ppm tested by Arsenic Limit Test.

(4) Lead : Disodium Succinate is tested by Purity (2) for 「Sodium Metaphosphate」(not more than 2.0 ppm).

(5) Readily Oxidizable Substances : Weigh 2 g of Disodium Succinate, dissolve in 20 mL of water and 30 mL of diluted sulfuric acid, add 4 mL of 0.1 N potassium permanganate, and keep 20°C. The color of the solution should not disappear within 3 minutes.

Loss on Drying When Disodium Succinate is dried for 2 hours at 120°C, the weigh loss should be within a range of 37.0 ~ 41.0%.

Assay Accurately weigh about 0.15 g of Disodium Succinate, previously dried, dissolve in 30 mL of acetic acid for nonaqueous titration, and titrate with 0.1 N perchloric acid (indicator : 1 mL of crystal violet-acetic acid solution) until the color of the solution changes from purple through blue to green. Separately, perform a blank test in the same manner.

1 mL of 0.1 N perchloric acid = 8.103 mg of $\text{C}_4\text{H}_4\text{Na}_2\text{O}_4$

Disodium DL-Tartrate

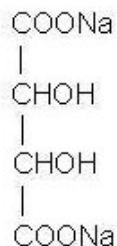

Chemical Formula: $\text{C}_4\text{H}_4\text{O}_6\text{Na}_2$

Molecular Weight: 194.06

CAS No.: 51307-92-7

Compositional Specifications of Disodium DL-Tartrate

Content Disodium DL-Tartrate, when calculated on the dried basis, should contain not less than 98.5% of disodium DL-tartrate ($\text{C}_4\text{H}_4\text{O}_6\text{Na}_2$).

Description Disodium DL-Tartrate occurs as colorless crystals or as a white crystalline powder.

Identification (1) Disodium DL-Tartrate solution (1→10) has no optical rotation.

(2) Proceed as directed under Identification for [L-Sodium Tartarate].

Purity (1) Clarity and Color of Solution, Acidity, and Alkalinity Sulfate : Proceed as directed under Purity (1), (3), (4) in [L-Sodium Tartarate].

(2) Readily oxidizable substances : Weigh 2.0 g of Disodium DL-Tartrate, dissolve in 20 mL of water and 30 mL of diluted sulfuric acid (1→20), and add 4.0 mL of 0.1 N potassium permanganate while keeping the temperature at 20°C. The pink color of the solution does not disappear within 3 minutes.

(3) Arsenic : It should be no more than 4.0 ppm tested by Arsenic Limit Test.

(4) Heavy Metals : 2 g of Disodium DL-Tartrate transfer into a quartz or porcelain crucible and carbonize by heating mildly. After cooling, add 2 mL of nitric acid and 5 drops of sulfuric acid, it is heated until white smoke disappears, which is then reduced to ash by further heating at 450~550°C. After cooling, 2 mL of hydrochloric acid is added, which is then evaporated to dryness in a water bath. 3 drops of hydrochloric acid and 10 mL of hot water are added to the resulting residue, which is then heated for 2 minutes. After cooling, 1 drop of phenolphthalein indicator solution is added, then ammonia solution is added until the color of the solution becomes pale red. The resulting solution is transferred into a Nestler cylinder by rinsing with water. 50 mL of test solution is prepared by adding 2 mL of diluted acetic acid (1→20) and water. When this solution tested by Heavy Metal Limit Test, the content should not be more than 20 ppm. Color standard solution is prepared by the following procedure. 2 mL of nitric acid, 5 drops of sulfuric acid, and 2 mL of hydrochloric acid are added and evaporated to dryness in a crucible that is made of the same material used for test solution preparation. 3 drops of hydrochloric acid are added to the residue, which is then transferred into another Nestler cylinder as described above. Finally, 2 mL of lead standard solution, 2 mL of diluted acetic acid (1→20), and add

water to make 50 mL.

Loss on Drying When Disodium DL-Tartrate is dried for 4 hours at 105°C, the loss should not be more than 0.5%.

Assay Proceed as directed under Assay in [L-Sodium Tartarate].

Disodium L-Tartrate

Disodium d-Tartrate

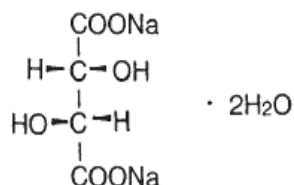

Chemical Formula: $\text{C}_4\text{H}_4\text{O}_6\text{Na}_2 \cdot 2\text{H}_2\text{O}$

Molecular Weight: 230.09

INS No.: 335(ii)

Synonyms: Disodium (+)-2,3-dihydroxybutanedioic acid

CAS No.: 6106-24-7

Compositional Specifications of Disodium L-Tartrate

Content Disodium L-Tartrate, when calculated on the dried basis, should contain not less than 99.0% of disodium L-tartrate ($\text{C}_4\text{H}_4\text{O}_6\text{Na}_2 = 194.06$).

Description Disodium L-Tartrate occurs as colorless crystals or as a white crystalline powder.

Identification (1) An aqueous solution (1→10) is dextrorotatory.

(2) Disodium L-Tartrate responds to the tests for Sodium Salt and Tartrate.

Purity (1) Clarity and Color of Solution : 1.0 g of Disodium L-Tartrate is dissolved in 20 mL of water. This solution should be almost clear.

(2) Specific rotation : Approximately 5 g of Disodium L-Tartrate is precisely weighed and dissolved in water to make 50 mL. Optical rotation of this solution is measured and it should be within a range of, $[\alpha]_D^{25} = +25.0 \sim +27.5^\circ$

(3) pH : pH of Disodium L-Tartrate solution (1→20) should be within a range of 7.0 ~ 9.0.

(4) Sulfate : When 1 g of Disodium L-Tartrate is tested by Sulfate Limit Test, its content should not be more than the amount that corresponds to 0.4 mL of 0.01 N sulfuric acid.

(5) Oxalate : 1.0 g of Disodium L-Tartrate dissolve in 10 mL of water and add 2 mL of calcium chloride solution (2→25). The solution should not turn turbid.

(6) Arsenic : It should be no more than 4.0 ppm tested by Arsenic Limit Test.

(7) Lead : When 5.0 g of Disodium L-Tartrate is tested by Atomic Absorption Spectrophotometry or Inductively Coupled Plasma Emission Spectroscopy, its content should not be more than 2.0 ppm.

(8) Mercury : When Disodium L-Tartrate is tested by Mercury Limit Test, its content should not be more than 1.0 ppm.

Loss on Drying When Disodium L-Tartrate is dried for 3 hours at 150°C, the weigh loss should be within a range of 14 ~ 17%.

Assay Accurately weigh about 0.2 g of Disodium L-Tartrate, previously dried, add 3 mL of formic acid, dissolve by warming, add 50 mL of glacial acetic acid for nonaqueous titration, and titrate with 0.1 N perchloric acid (indicator : 1 mL of crystal violet-glacial acetic acid solution). The end point is until the color of the solution changes from purple through blue to green. Perform a blank test in the same manner.

1 mL of 0.1 N perchloric acid = 9.703 mg of $C_4H_4O_6Na_2O_6$

Disodium 5'-Uridylate

Sodium 5'-Undylate



Chemical Formula: $C_9H_{11}N_2Na_2O_9P$

Molecular Weight: 368.15

CAS No.: 3387-36-8

Compositional Specifications of Disodium 5'-Uridylate

Content When Disodium 5'-Uridylate, when calculated on the dried basis, should contain within a range of 97.0 ~ 102.0% of disodium 5'-uridyate ($C_9H_{11}N_2Na_2O_9P$).

Description Disodium 5'-Uridylate occurs as colorless to white crystals or as a white crystalline powder, having a slight, characteristic taste.

Identification (1) Dissolve 20 mg of Disodium 5'-Uridylate in 100 mL of 0.01 N hydrochloric acid and 0.01 N hydrochloric is added to 10 mL of this solution to make 100 mL. The solution exhibits an absorption maximum at a wavelength of 262 ± 2 nm.

(2) To 3 mL of Disodium 5'-Uridylate solution (3→10,000), add 1 mL of hydrochloric acid and 1 mL of bromine solution, heat on a water bath for 30 minutes, remove the bromine by blowing with air, and add 0.2 mL of a solution of orcinol in ethanol (1→10). To this solution, add 3 mL of a solution of ferric ammonium sulfate in hydrochloric acid (1→1,000), and heat in a water bath for 20 minutes. A green color becomes.

(3) To 5 mL of Disodium 5'-Uridylate solution (1→20), add 2 mL of magnesia solution. No precipitate is formed. Then add 7 mL of nitric acid, boil for 10 minutes, and neutralize with sodium hydroxide solution (1→25). The solution responds to the test for Phosphate (2).

(4) Disodium 5'-Uridylate responds to test of Sodium Salt in Identification.

Purity (1) Clarity and Color of Solution : When 0.5 g of Disodium 5'-Uridylate dissolved in 10 mL of water, the solution should be Colorless and almost clear.

- (2) pH : pH of Disodium 5'-Uridylate solution (1→20) should be within a range of 7.0~8.5 as determined by glass electrode method.
- (3) Arsenic : It should be no more than 4.0 ppm tested by Arsenic Limit Test.
- (4) Lead : Disodium 5'-Uridylate is tested by Purity (2) for Sodium Metaphosphate(not more than 2.0 ppm).
- (5) Absorption Ratio : Weigh 20 mg of Disodium 5'-Uridylate, and dissolve in diluted hydrochloric acid (1→1,000) to make 1,000 mL. Measure absorbances A1, A2, and A3 of 0.01N hydrochloric acid solution of Disodium 5'-Cytidylate(1→50,000) at wavelengths of 250 nm, 260 nm, and 280 nm, respectively. A1/A2 is 0.7 ~ 0.78, and A3/A2 is 0.34 ~ 0.42.
- (6) Other decomposed substances of ribonucleic acids : Measure 1 $\mu\ell$ of the solution of Disodium 5'-Uridylate (0.1→10) as the test solution. Perform Thin-Layer Chromatography, using an ethanol ethylene glycol monomethyl ether-diluted hydrochloric acid (1→10) mixture (2:2:1) as the developing solvent. Only one spot is observed. For the thin layer plate, use microcrystalline cellulose for thin-layer chromatography dried at 60 ~ 80°C for 20 minutes as the support. Stop the development when the solvent front rises 10 cm above the original line, air-dry, and observe under ultraviolet light (about 250 nm wavelength) in a dark place. However, reference solution is not used.

Water Content Water content of approximately 0.15 g of Disodium 5'-Uridylate as determined by water content determination method (Karl-Fischer Method) should not be more than 26%. In this case, sample transfer into a dried titration flask, where 10 mL of Karl-Fisher methyl alcohol is added. A certain amount of Karl-Fisher solution is added so that there is an excess of approximately 10 mL. Then the flask is capped and shaken for 20 minutes. It is titrated with water-methyl alcohol standard solution. Separately, a blank test is carried out by following the same procedure.

Assay Accurately weigh about 500 mg of Disodium 5'-Uridylate, dissolve in 0.01 N hydrochloric acid to make 1,000 mL, measure 10 mL of this solution, and add 0.01 N hydrochloric acid to make 250 mL. Use this solution as the test solution. Measure absorbance A of the test solution at a wavelength of 260 nm, and calculate the content by the following formula:

Content of disodium 5'-uridyate ($C_9H_{11}N_2Na_2O_9P$)

$$= \frac{500}{\text{weight of the sample(mg)}} \times \frac{185.9 \times A}{100 - \text{water content(\%)}} \times 100$$

Dry Formed Vitamin A

Definition Dry Formed Vitamin A is powdered vitamin A oil.

Compositional Specifications of Dry Formed Vitamin A

Content Dry Formed Vitamin A should contain within a range of 90.0 ~ 120.0% of the indicated amount of vitamin A. 150 mg of vitamin A corresponds to 500,000 units of international standard.

Description Dry Formed Vitamin A occurs as a light yellow to light red-brown powder.

Identification Grind 0.5 g of Dry Formed Vitamin A in a mortar, add 10 mL of hot water, stir thoroughly to make milky emulsion, add 10 mL of ethanol to break emulsion, and transfer the mixture into a flask. Add 20 mL of hexane, shake well, and either allow to stand or centrifuge to separate into two layers. Take the hexane layer, wash with 20 mL of water by shaking well, separate the water layer, and evaporate the hexane layer to dryness under reduced pressure. To residue, add 1 mL of chloroform, and 5 mL of antimony trichloride solution. The color of the solution becomes to blue.

Purity (1) Decay : Dry Formed Vitamin A should not have unpleasant odor.

(2) Arsenic : It should be no more than 4.0 ppm tested by Arsenic Limit Test.

(3) Lead : When 5.0 g of Dry Formed Vitamin A is tested by Atomic Absorption Spectrophotometry or Inductively Coupled Plasma Emission Spectroscopy, its content should not be more than 2.0 ppm.

Loss on Drying When Dry Formed Vitamin A is dried for 4 hours in a vacuum desiccator, the weight loss should be not more than 5%.

Residue on Ignition When thermogravimetric analysis is done with 2 g of Dry Formed Vitamin A, the residue should be not more than 5%.

Assay Accurately weigh about 5 g of Dry Formed Vitamin A, add a small amount of hot water, stir thoroughly to milky emulsion, transfer into a flask, and proceed as directed under Assay in 「Vitamin A in Oil」.

Storage Standards of Dry Formed Vitamin A

Store in a light-shielded, hermetic container filled with nitrogen.

Enzymatically Decomposed Apple Extract

Definition Enzymatically Decomposed Apple Extract is obtained by the following process. Pulps are removed from juices of apples (*Malus pumila* MILLER) of rosaceae. The clear supernatant is enzymatically treated, which is then purified. The effective components are chlorogenic acid and catechins. Diluent, stabilizer, or solvents can be added for the purpose of content adjustment and quality preservation.

Compositional Specifications of Enzymatically Decomposed Apple Extract

Content Enzymatically Decomposed Apple Extract contains 90 ~ 130% of the indicated amount as chlorogenic acid and catechins.

Description This is a yellowish brown powder with a hint of apple scent.

Identification 10 g of Enzymatically Decomposed Apple Extract dissolve in 100 mL of water. When 2 drops of ferric chloride solution are added to 5 mL of this solution, it turns blackish blue. Upon settling, blackish blue precipitates are formed.

Purity (1) Arsenic : It should be no more than 4.0 ppm tested by Arsenic Limit Test.

(2) Lead : When 5.0 g of Enzymatically Decomposed Apple Extract is tested by Atomic Absorption Spectrophotometry or Inductively Coupled Plasma Emission Spectroscopy, its content should not be more than 2.0 ppm.

Assay Precisely 20 mg of Enzymatically Decomposed Apple Extract is mixed with a mixture of 0.2M phosphate buffer solution (pH 3.0) : methyl alcohol : water (2 : 3 : 15) (total volume = 25 mL). It is filtered through a 0.45 μ m Millipore filter (Test Solution). Separately, a mixed standard solution is prepared with a mixture of 0.2 M phosphate buffer solution (pH 3.0) : methyl alcohol : water (2 : 3 : 15) so that the final concentrations are epigallocatechin 360ppm, chlorogenic acid 55ppm, epicatechin 100ppm, epigallocatechin gallate 80ppm, and epicatechin gallate 70ppm. 20 μ l each of mixed standard solution and Test Solution is injected into liquid chromatography under the following Operation Conditions. The contents of chlorogenic acid and catechins are separately calculated by the following equations.

① chlorogenic acid

$$\text{content(\%)} = \frac{\text{concentrate of chlorogenic acid}}{\text{standard solution (ppm)}} \times \frac{S_a}{S_t} \times \frac{D}{W} \times \frac{100}{10^6}$$

S_a : Peak area of Test Solution

S_t : Peak area of Standard Solution

W : Weight of sample(g)

D : Dilution factor of Test Solution

② catechins : The content of catechins is a sum of the contents of epigallocatechin, epicatechin,

epigallocatechin gallate, and epicatechin gallate.

$$\text{Content(\%)} = \frac{\text{concentration of corresponding catechin standard solution(ppm)}}{\text{concentration of corresponding catechin standard solution(ppm)}} \times \frac{S_a}{S_t} \times \frac{D}{W} \times \frac{100}{10^6}$$

S_a : Peak area corresponding catechin in Test Solution

S_t : Peak area corresponding catechin in Standard Solution

W : Weight of sample(g)

D : Dilution factor of Test Solution

Operation Conditions

-Detector : UV detector, 280 nm

-Column : μ Bondapak C₁₈ (3.9 \times 300 mm, 10 μ m) or its equivalent

-Column Temperature : 40°C

-Mobile Phase : acetonitrile : acetic acid : methyl alcohol : water
(113 : 5 : 20 : 862)

-Flow Rate : 1 mL/min

• 0.2 M Phosphate Buffer Solution (pH 3.0) : 0.2 M potassium phosphate, monobasic solution and 0.2 M phosphoric acid are well mixed. Its pH is adjusted to 3.0.

Enzymatically Decomposed Lecithin

Definition Enzymatically Decomposed Lecithin is obtained by decomposing lecithin with enzyme. Its major components are rhizolecithin and phosphatidic acid.

Compositional Specifications of Enzymatically Decomposed Lecithin

Description Enzymatically Decomposed Lecithin is white ~ brown powder or granule, or pale yellow ~ dark brown viscous liquid with characteristic scent and taste.

Identification 1 g of Enzymatically Decomposed Lecithin is placed in a flask for decomposition. Add 5 g of powdered potassium sulfate, 0.5 g of copper sulfate, and 20 mL of sulfuric acid. The flask is tilted to 45°C angle and gently heated so that it doesn't bubble. Then the temperature is raised to boil until the solution becomes transparent blue. It is then heated for 1 ~ 2 hours and cooled and the same amount of water is added. 10 mL of ammonium molybdate (1→5) is added to 5 mL of the resulting solution. Upon heating yellow precipitates are formed.

Purity (1) Acid value : 2 g of Enzymatically Decomposed Lecithin is precisely weighted and dissolved in 50 mL of toluene. After adding 50 mL of alcohol previously neutralized with 0.1N potassium hydroxide solution while using phenolphthalein TS as indicator, heat until the sample is dissolved. This mixture is used as the test solution, and when it is proceeded as directed under Acid value in Fats Test, the tvalue of the solution should not be more than 45.

(2) Toluene Insoluble substances : Approximately 5 g of Enzymatically Decomposed Lecithin is precisely weighted and dissolved in 100 mL toluene. Insoluble substances are filtered through a glass filter (1G4) that is previously weighted. It is washed several times with 25 mL of toluene. The residue along with the filter is dried for 1 hour at 105°C and cooled in a desiccator and weighted. Or 5 g of Enzymatically Decomposed Lecithin is precisely weighted and dissolved in 100 mL of toluene in a Erlenmeyer flask. Transfer 50 mL of the solution into a centrifuge tube, which is then centrifuged for 15 minutes at 3,000 rpm. The supernatant is removed. The remaining 50 mL of the solution is centrifuged by the same method using the same tube. The inner wall of the flask is washed with 50 mL of toluene into the same tube, which is then centrifuged by the same method. The supernatant is discarded. This is repeated twice. The insoluble substances are dried in the tube for 2 hours at 105°C, cooled in a desiccator, and weighted. The content should not be more than 0.3%.

(3) Acetone Insoluble substances

Preparation of sample : If Enzymatically Decomposed Lecithin contains moisture, it is dehydrated and dried by heating at 80°C and evaporating under vacuum. It is then dissolved in toluene and the solution is filtered through a filter paper to remove impurities. Toluene from the filtrate is removed by evaporation under a reduced pressure in a round bottom flask. The residue is crude sample.

Test Procedure : 10 g of crude sample is precisely weighted into a 300 mL beaker, and then 200 mL of acetone saturated with phospholipid that is cooled in ice water is added. It is thoroughly mixed and set aside for 30 minutes. Acetone insoluble substances settle down at the bottom of the beaker

and the solution becomes clear. The supernatant is vacuum filtered with a glass filter, precisely weighted Acetone insoluble substances are washed three times with 30 mL of acetone saturated with phospholipid that is cooled in ice water. Acetone insoluble substances and wash acetone are transferred into a glass filter, which is then vacuum filtered. Acetone insoluble substances are dried for 1 hours under a reduced pressure. Or, 2.0 g of crude sample is precisely weighted into a 50 mL graduated centrifuge tube with a stopper (precisely weighted) and dissolved by heating in 5 mL of acetone saturated with phospholipid that is cooled in ice water. The tube is then cooled for 15 minutes in an ice bath (also a glass stirring rod is precisely weighted and cooled for 15 minutes in an ice bath). Then the tube is filled to 50 mL with acetone saturated with phospholipid, which is stirred thoroughly while hitting. It is cooled for 15 minutes in an ice bath and then stirred again. It is then centrifuged at 3,000 rpm for 15 minutes and the supernatant is discarded. This procedure is repeated twice. Acetone insoluble substances are dried along with the centrifuge tube for 2 hours at 105°C and cooled in a desiccator. The content of acetone insoluble substances is calculated by the following equation and it should not be less than 56%.

$$\text{Acetone insoluble substances(\%)} = \frac{\text{Insoluble substances(g)}}{\text{weight of the sample(g)}} \times 100$$

Solutions

- Acetone Saturated with Phospholipid : Acetone insoluble substances (phospholipid) are obtained by treating crude sample with acetone (as described above). 1 g of the insoluble substances is placed in a 1,000 mL flask with a stopper and dissolved in acetone (total volume = 1,000 mL). The solution is cooled in an ice bath while shaking occasionally. This acetone is saturated with phospholipid. The supernatant is filtered before use.

(4) Peroxide Value : 5 g of Enzymatically Decomposed Lecithin is precisely weighted into a 250 mL of Erlenmeyer flask with a stopper. It is then dissolved to a clear solution in 35 mL mixture of acetic acid and chloroform (3 : 2) by gently shaking. Clean nitrogen is passed through to replace air in the flask. 1 mL of potassium iodide solution is accurately added while nitrogen is passed through. A stopper is placed immediately and the flask is shaken for 1 minute. It is then set aside for 5 minutes in a dark place. 75 mL of water is added and shaken vigorously with a stopper. It is then titrated with 0.01 N sodium thiosulfate solution (indicator : starch solution). Peroxide value is obtained from the following equation. It should not be more than 10. Separately, a blank test is carried out for correction.

$$\text{Peroxide Value} = \frac{\text{Consumed amount of 0.01N sodium thiosulfate solution(mL)}}{\text{weight of the sample(g)}} \times 10$$

(5) Arsenic : It should be no more than 4.0 ppm tested by Arsenic Limit Test.

(6) Lead : When 5.0 g of Enzymatically Decomposed Lecithin is tested by Atomic Absorption Spectrophotometry or Inductively Coupled Plasma Emission Spectroscopy, its content should not be more than 2.0 ppm.

(7) Mercury : When Enzymatically Decomposed Lecithin is tested by Mercury Limit Test, its content should not be more than 1.0ppm.

Water Content Water content of Enzymatically Decomposed Lecithin is determined by direct titration method in water determination (Karl-Fisher Titration) and should not be more than 2.0%. However, chloroform : methyl alcohol mixture (4:1) is used instead of methyl alcohol for Karl-Fisher titration.

Enzymatically Modified Hesperidine

Definition Enzymatically Modified Hesperidine is obtained by adding glucose to hesperidine using α -glucosyltransferase. Its component is α -glucosylhesperidine.

Compositional Specifications of Enzymatically Modified Hesperidine

Content Dried the mixture form should contain no less than 27% of Enzymatically Modified Hesperidine as hesperetin glycoside and the mono form should contain no less than 70% of Enzymatically Modified Hesperidine as α -monoglucosylhesperidine.

Description Enzymatically Modified Hesperidine occurs as a light yellow ~ yellowish brown powder or crystalline powder with a slightly characteristic odor.

Identification (1) 5 mg of Enzymatically Modified Hesperidine dissolve in 10 mL of 50% ethyl alcohol. When 1 ~ 2 drops of ferric chloride solution (1→500) are added to this solution, it becomes brown in color.

(2) A solution of 10 mg of Enzymatically Modified Hesperidine in 500mL of water has a maximum absorption band in the wavelength range of 280-286nm.

(3) Approximately 0.5g of Enzymatically Modified Hesperidine is completely dissolved in 100mL of water. Use this solution as the test solution. Aside from that, approximately 0.2g of standard Hesperidine dissolve in 50 mL of sodium hydroxide solution (1→500). Prepare 40 mL of the standard solution through applying the mobile phase of the high performance liquid chromatography to 10 mL of the previous solution. When performed the high performance liquid chromatography for the test solution and the standard solution following the conditions listed below, peak of Enzymatically Modified Hesperidine should be at the location with earlier retention time compared to that of the Hesperidine, but it should display relatively similar UV absorption spectrum.

Operating Conditions

Detector: Photodiode array detector (Measured wavelength 280nm, 200-400nm)

Packing material: chemically bonded Octadecylsilane

Column: inner diameter 3.9-4.6mm, length 150-300mm

Column temperature: 40°C

Mobile phase: water : acetonitrile (4:1)

Flow rate: 0.5mL/min

Injection volume: 10ul

Purity (1) Arsenic: It should be no more than 2.0 ppm tested by Arsenic Limit Test.

(2) Lead : When 5.0 g of Enzymatically Modified Hesperidine is tested by Atomic Absorption Spectrophotometry or Inductively Coupled Plasma Emission Spectroscopy, its content should not be more than 10.0 ppm.

(3) Clarity and Color of Solution : When 0.5 g of Enzymatically Modified Hesperidine is dissolved in 100 mL of water, the solution should be clear.

Loss on Drying When 1.0 g of Enzymatically Modified Hesperidine is dried for 3 hours at 105°C, the weight loss should not be more than 6%.

Assay 1.0g of Enzymatically Modified Hesperidine is precisely weighted and dissolved in water to make 100 mL solution. 1 mL of this solution dissolve with 100 mL of distilled water and use this solution as the test solution. Aside from this, dry the standard Hesperidine compound in 135°C for 2 hours and then dissolve 1.0g of dried standard Hesperidine with 0.5N Sodium hydroxide solution and mark it up to 100mL. Dissolve and mark up 1.0mL of this solution to 100mL with water which is considered as the standard solution. Calculate the hesperetin glycoside (C) under the operation conditions shown below based on the high performance liquid chromatography through the sum of the monoglycosylhesperidine (A₁), diglycosylhesperidine (A₂), triglycosylhesperidine (A₃), tetraglycosylhesperidine (A₄), pentaglycosylhesperidine (A₅), and the quantity of hesperidine (B). However, calculate only the monoglycosylhesperidine (A₁) for the mono formation.

$$A_n = \frac{A_s \times a_t}{A_t \times a_s} \times F \times 100$$

$$B = \frac{B_s \times a_t}{A_t \times b_s} \times 100$$

$$C = A_1 + A_2 + A_3 + A_4 + A_5 + B$$

A_n: The specific quantity of glycosylhesperidine for selected from A1~A5 during the examination

A_s: Each specific glycosylhesperidine peak area of the test solution

A_t: The hesperidine peak area of the standard hesperidine solution

a_s: The amount (g) collected in respect to the examination

a_t: The collected amount of the standard (purity correction) hesperidine (g)

F: The coefficient for the hesperidine conversion = M/610, M: molar mass of each glycosylhesperidine type (M: 772 for monoglycosylhesperidine, 934 for diglycosylhesperidine, 1096 for triglycosylhesperidine, 1258 for tetraglycosylhesperidine, 1420 for pentaglycosylhesperidine)

B: The amount of hesperidine (%) during the examination

B_s: The hesperidine peak area of the test solution

b_s: The amount collected (g) in respect to the examination

C: The amount of hesperetin glycoside during the examination (%)

Operating Condition

Detector: UV (Measured wavelength 280nm)

Column: Capcell pack C₁₈ or its equivalent

Column temperature: 45°C

Mobile phase: Acetonitrile : water (20:80)

Flow rate: 0.5mL/min

Injection volume: 10 µl

Enzymatically Modified Rutin

Definition Enzymatically Modified Rutin is obtained after removing rhamnose from rutin by treating with partially hydrolyzing enzyme. Or it is obtained by treating rutin with transaminase followed by reacting with glucose. Its component is α -glycorutin.

Compositional Specifications of Enzymatically Modified Rutin

Content Dried Enzymatically Modified Rutin should contain no less than 60.0% of enzymatically modified rutin

Description Enzymatically Modified Rutin is yellow ~ yellowish brown powder with a slight characteristic scent.

Identification (1) 5 mg of Enzymatically Modified Rutin dissolve in 10 mL of ethyl alcohol. When 1 ~ 2 drops of ferric chloride solution (1→50) are added to this solution, it becomes brown in color.

(2) When 5 mL of sodium hydroxide solution (1→1,000) is added to 5 mg of Enzymatically Modified Rutin, the solution shows orange ~ yellow color.

(3) 5 mg of Enzymatically Modified Rutin dissolve in water, where 2 mL of hydrochloric acid and 0.05 g of magnesium powder are added. The color of the solution slowly changes to orange.

(4) 0.1 g of Enzymatically Modified Rutin dissolve in 100 mL of 1 N sulfuric acid. When this solution is boiled for 2 hours and cooled, yellow precipitates are formed..

(5) A solution of 0.01 g of Enzymatically Modified Rutin in 500 mL of 0.085% phosphoric acid solution has a maximum absorption band near 258 nm and 351 nm.

Purity (1) Arsenic : It should be no more than 2.0 ppm tested by Arsenic Limit Test.

(2) Lead : When 5.0 g of Enzymatically Modified Rutin is tested by Atomic Absorption Spectrophotometry or Inductively Coupled Plasma Emission Spectroscopy, its content should not be more than 10.0 ppm.

Assay Enzymatically Modified Rutin is precisely weighted and dissolved in 50 mL of water so that the measured absorption lies within a range of 0.3~0.7. If necessary, it is filtered through a glass filter, which is washed with water. The filtrate and wash water are combined so that the total volume is 100 mL. 1 mL of this solution is diluted to 100 mL with 0.085% phosphoric acid (Test Solution). Separately, rutin standard is dried for 2 hours at 135°C and approximately 0.2g of it is precisely weighted and dissolved in 80 mL of methyl alcohol by heating. Cool the solution, this solution is diluted to 100 mL with methyl alcohol. 1 mL of this solution is further diluted to 100 mL with 0.085% phosphoric acid (Standard Solution). Using 0.085% phosphoric acid as a reference, absorption near 351 nm is measured for Test (A1) and Standard (A2) Solutions. The content of enzymatically modified rutin (the amount converted as rutin) is obtained by the following equation. The amount converted as rutin is the content enzymatically modified rutin.

$$A = \frac{A_1 \times R}{A_2 \times S} \times 100$$

A : Content of enzymatically treated rutin (converted as rutin) (%)

A1 : Absorbance of Test Solution

A2 : Absorbance of Standard Solution

S : Amount of sample (mg)

R : Amount of rutin Standard (mg)

Enzymatically Modified Stevia

Synonyms: Glucosyl stevia

Definition Enzymatically Modified Stevia is obtained by addition of glucose to stevia extracts using α -glucosyltransferase. Its components are α -glucosylstevioside, etc.

Compositional Specifications of Enzymatically Modified Stevia

Content If Enzymatically Modified Stevia is converted to a dehydrated form, it should contain no less than 80.0 % of steviolglycoside and not more than 15.0 % of unreacted steviolglycoside.

Description Enzymatically Modified Stevia is white ~ pale yellow powder, flakes, or granule with a cool, sweet taste. It have a slight characteristic scent.

Identification (1) 1.2 g of Enzymatically Modified Stevia dissolve in 100 mL of water, where 100 mL of n-butyl alcohol is added and shaken. It is set aside to separate two phases. N-butyl alcohol phase is taken and filtered if necessary. 5 mL of anthrone solution is slowly added along the inner wall of a container with 5 mL of this solution. The boundary area becomes blue ~ green in color.

(2) 40 mL of sulfuric acid (1→5) is added to 2.4 g of Enzymatically Modified Stevia in a flask. A reflux condenser is attached to the flask, which is heated for 2 hours in a water bath. Cool the solution, it is extracted twice with 50 mL each of ether. The extracts are washed twice with water, dehydrated with anhydrous sodium sulfate, and evaporated to dryness. The residue dissolve in 10 mL of methyl alcohol, where 10 mL of water is added. Formed precipitates are filtered. These precipitates are washed with a small amount of 50% methyl alcohol and dried for 2 hours at 105°. The melting point of residue should be 226~230°.

(3) 2.4 g of Enzymatically Modified Stevia dissolve in 100 mL of water. The solution is halved. One portion is tested by (3) Assay for Unreacted Steviolglycoside in Assay and a group of peaks should be observed after the peak for Rebaudioside A. 500 GUN of glucoamylase per 1g of Enzymatically Modified Stevia is added to the other portion of the solution, which is reacted for 24 hours at 55°. It is then filtered through a 0.45 μ m Millipore filter and the filtrate is analyzed by Assay for Unreacted Steviolglycoside. The group of peaks observed after the peak of Rebaudioside A should almost disappear and the area for the group of peaks before the peak of Rebaudioside A should increase.

Purity (1) Arsenic : It should be no more than 2.0 ppm tested by Arsenic Limit Test.

(2) Lead : When 5.0 g of Enzymatically Modified Stevia is tested by Atomic Absorption Spectrophotometry or Inductively Coupled Plasma Emission Spectroscopy, its content should not be more than 1.0 ppm.

Loss on Drying When 1 g of Enzymatically Modified Stevia is dried for 4 hours at 105°C, the weight loss

should not be more than 6%.

Residue on Ignition When Residue on Ignition analysis is done with accurately weighted 1 g of Enzymatically Modified Stevia, the amount of Residue on Ignition should not be more than 1%.

Assay (1) Steviolglycoside : The content of steviolglycoside is a sum of ① steviol content and ② sugar content in glycoside.

① Assay for Steviol : Approximately 100 mg of Enzymatically Modified Stevia is precisely weighted into a 30 mL Erlenmeyer flask, where 10 mL of 20% sulfuric acid is added and a reflux condenser is attached. It is heated for 2 hours in a water bath and cooled in a running water. The solution transfer into a separatory funnel using 10 mL of water. The flask is again washed three times with 30 mL each of ether, which is added to the funnel. The funnel is well shaken and set aside. The aqueous layer is discarded and the ether phase is washed twice with 20 mL each of water. The aqueous layer is completely removed. The ether phase transfer into a separate flask. The funnel is washed twice with 10 mL each of ether, which is added to the flask. 15g of anhydrous sodium sulfate is added and mixed well by shaking. The ether phase is decanted into another flask. The remaining anhydrous sodium sulfate washed twice 10 mL each of ether, which is added to the flask. After evaporate the ether, the residue dissolve in 10 mL of ethyl acetate, where 3 mL of diazomethane ether solution is added and a cap is placed. It is then set aside for 20 minutes while stirring occasionally. 0.5 mL of acetic acid is well mixed with this solution, where 2 mL of an internal standard solution of squalene in n-butyl alcohol (12.5 mg/mL) (Test Solution). Separately, 50 mg of stevioside standard (previously dried for 2 hours at 105°C) is precisely weighted and treated by the same procedure as Test Solution (Standard Solution). Test and Standard Solutions are separately injected into gas chromatography under the following Operation Conditions. The content of steviol is calculated by the following equation.

$$\text{Steviol Content (\%)} = \frac{A}{A_s} \times \frac{\text{weight of stevioside standard(mg)}}{\text{weight of the sample on the anhydrous basis(mg)}} \times 100 \times K$$

A : Peak area ratio of iso-steviol methyl ester in Test Solution vs. squalene

A_s : Peak area ratio of iso-steviol methyl ester in Standard Solution vs. squalene

K : Conversion factor to steviol 318.46/804.88 = 0.3957

Operation Conditions

-Column : DB-17 (30 m × 0.25 μm × 0.25 mm) or its equivalent

-Detector : Flame Ionization Detector(FID)

-Temperature at injection hole : 260°C

-Column Temperature : 235°C

-Detector Temperature : 260°C

-Carrier Gas and Flow Rate : Nitrogen or helium, flow rate and column temperature are adjusted so that the peak of iso-steviol methyl ester appears in 7 ~ 15 minutes.

② Assay for Sugar in Glycoside

- Preparation of Test Solutions : Approximately 1.0 g of Enzymatically Modified Stevia is precisely weighted and dissolved in 50 mL of water. The solution transfer into a 2.5 cm (diameter) resin column that is made using 50 mL of adsorption resin (Amberlite XAD-7) for enzymatically modified stevia. It is then drained out for 1 minute at a rate of 3 mL/min or lower. The column is washed with 250 mL of water. Adsorbed matter is eluted for 1 minute using 250 mL of 50% ethyl alcohol or 90% methyl alcohol at a flow rate of 3 mL/min or lower. The eluted solution is concentrated and dried with a vacuum evaporator. The residue dissolve in water (total volume = 500 mL). 1 mL of this solution is diluted to 50 mL with water (Test Solution)
- Test Procedure : 2 mL of Test Solution is placed in a test tube with a stopper. While cooling in an ice bath, exactly 6 mL of anthrone solution is added to the test tube and well mixed with Test Solution by shaking. It is then heated for exactly 16 minutes in heating water bath and cooled in an ice bath. Absorption of this solution is measured at 620 nm using water as a reference. Concentration of glucose ($\mu\text{g/mL}$) in Test Solution is obtained from a glucose standard curve. Standard Solutions are prepared using glucose (dried for 2 hours at 105°) so that each 1 mL solution contains 10 μg , 30 μg , and 50 μg of glucose. Glucose Standard Curve prepared by following the same procedure as Test Solution with Standard Solutions. The content of sugar in steviolglycoside is obtained by the following equation.

$$\text{Amount of sugar in steviolglycoside(\%)} = \frac{b \times 0.9 \times 50 \times 500}{Y \times 1,000 \times 1,000} \times 100 = \frac{2.25b}{Y}$$

b : Glucose concentration in Test Solution from Standard Curve ($\mu\text{g/mL}$)

Y : Amount of sample as a dehydrated form (g)

(2) Assay for Unreacted Steviolglycoside : Approximately 50~100 mg of Enzymatically Modified Stevia which is previously dried for 2 hours at 105°C is precisely weighted and dissolved in water:acetonitrile(7:3) mixture to make 50 mL, test solution. Separately, Stevioside and Rebaudioside A standard are dried for 2 hours at 105°C . 50 mg of each standard dissolve in water:acetonitrile(7:3) mixture to make 50 mL, Standard Solutions. Test and Standard Solutions are separately injected into liquid chromatography under the following operation conditions and the total amount of steviolglycoside is calculated. Peak areas and the retention time of dulcoside A, rubusoside, rebaudioside A, rebaudioside B, rebaudioside C, rebaudioside D, rebaudioside F, steviolvioside and

stevioside in Test Solution are obtained. and compare them for the identification. The amount of the 8 components except rebaudioside A, and the amount of rebaudioside are obtained by the following formula. The sum of these amount is the amount of steviol glycoside.

$$X (\%) = \frac{W_s}{W} \times \frac{A_x \times f_x}{A_s} \times 100$$

$$\text{Rebaudioside A\%} = \frac{W_R}{W} \times \frac{A_x}{A_R} \times 100$$

X : Each steviol glycoside

W_s : Amount of Stevioside in standard solution (mg)

W_s : Amount of Ribaudioside A in standard solution (mg)

W : Amount of Sample in test solution (mg)

A_s : Peak area of stevioside in standard solution

A_R : Peak area of Rebaudioside A in standard solution

A_x : Peak area of X in test solution

f_x : Ratio of molecular weight of X to stevioside

(stevioside 1.00, rebaudioside A 1.20, rebaudioside B 1.00, rebaudioside C 1.18, rebaudioside D 1.40, Ribaudioside F 1.16, dulcoside A 0.98, rubusoside 0.80, steviolvioside 0.80)

Operation Conditions

-Detector : UV 210 nm

-Column : Capcell pak C18 MG II(4.6mm×250mm, 5μm) or its equivalent

-Column Temperature : 40°C

-Mobile Phase : Acetonitrile : 10 mM phosphoric acid buffer(pH 2.6) (32:68)

-Flow Rate : 1.0 mL/min

- The amount of Injection : 10 μL

Erythorbic Acid

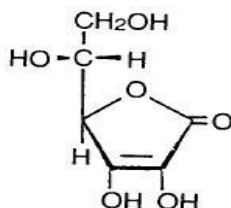

Chemical Formula: C₆H₈O₆

Molecular Weight: 176.13

INS No.: 315

Synonyms: D-Araboascorbic acid; Isoascorbic acid

CAS No.: 89-65-6

Compositional Specifications of Erythorbic Acid

Content Erythorbic Acid, when calculated on the dried basis, should contain not less than 99.0% of erythorbic acid (C₆H₈O₆).

Description Erythorbic Acid occurs as white to yellowish white crystals or crystalline powder. It is odorless and has an acid taste.

Identification (1) Dissolve 0.1 g of Erythorbic Acid in 100 mL of metaphosphoric acid solution (1→50).

To 5 mL of this solution, add drop wise iodine solution until a slightly yellow color develops. To the solution, add 1 drop of cupric sulfate solution (1→1,000) and 1 drop of pyrrole, and warm in a water bath at 50-60°C for 5 minutes. A blue to blue-green color develops.

(2) To 10 mL of Erythorbic Acid solution (1→100), add 1 mL of potassium permanganate solution. A pink color develops, and this color disappears immediately.

Purity (1) Specific Rotation : Approximately 1 g of Erythorbic Acid is accurately weighed, which is dissolved in freshly boiled and cooled water so that the total volume becomes 10 mL. Optical rotation of this solution should be within a range of $[\alpha]_D^{25} = -16.5 \sim -18.0^\circ$.

(2) Melting Point : Melting point of Erythorbic Acid should be within a range of 164 ~ 171°C.

(3) Arsenic : It should be no more than 4.0 ppm tested by Arsenic Limit Test.

(4) Lead : When 5.0 g of Erythorbic Acid is tested by Atomic Absorption Spectrophotometry or Inductively Coupled Plasma Emission Spectroscopy, its content should not be more than 2.0 ppm.

Loss on Drying When Erythorbic Acid is dried for 3 hours in a vacuum desiccator (silica gel), the weight loss should not be more than 0.4%.

Residue on Ignition When thermogravimetric analysis is done with Erythorbic Acid, the residues should not be more than 0.3%.

Assay Dissolve 0.4 g of Erythorbic Acid, previously dried and accurately weighed, in metaphosphoric acid solution (1→50) to make 100 mL, measure exactly 50 mL of this solution, and titrate with 0.1 N iodine

solution (indicator : starch solution).

1 mL of 0.1 N iodine solution = 8.806 mg of $C_6H_8O_6$

Erythritol

Erythrite

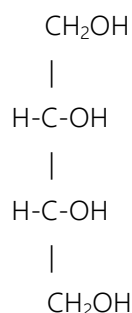

Chemical Formula: $\text{C}_4\text{H}_{10}\text{O}_4$

Molecular Weight: 122.12

Synonyms: Erythrite; Meso-erythritol

INS No.: 968

CAS No.: 149-32-6

Definition Erythritol is obtained by filtering, purifying, crystallizing, and washing the fermented liquid obtained from yeast such as *Moniliella pollinis*, *Trichosporonoides megachilensis* or *Candida lipolytica* (*Yarrowia lipolytica*). Its component is erythritol.

Compositional Specifications of Erythritol

Content Dried Erythritol should contain no less than 99.0% of erythritol ($\text{C}_4\text{H}_{10}\text{O}_4$).

Description Erythritol is scentless white crystalline powder with a sweet taste.

Identification (1) Erythritol is readily soluble in water, slightly soluble in alcohol, and insoluble in ether.

(2) Melting point should be in a temperature range of 119~123°C.

(3) When Erythritol is tested by Assay, the retention time of main peak of Test Solution is identical to that of erythritol standard solution.

Purity (1) Reducing Sugar (as glucose) : 500 mg of Erythritol is precisely weighted and dissolved in 2 mL of water and shaken, where 2 mL of Fehling solution is added. It is then heated to boil and cooled (Test Solution). Separately, 2 mL of Fehling solution is added to 2 mL of glucose solution (containing 0.75 mg of glucose per 1 mL), which is heated to boil and cooled (Standard Solution). When two solutions are compared, precipitates in Test Solution should be less than the reddish brown precipitates in Standard Solution (Not more than 0.3%).

(2) Ribitol and Glycerol : Erythritol is tested by Assay and the contents of ribitol and glycerol are obtained by the following equations. The sum of the contents should not be more than 0.1%. The relative retention times for erythritol, glycerol, and ribitol are 1.0, 1.10, and 0.93, respectively.

$$\text{Ribitol(\%)} = \frac{\text{peak area of ribitol}}{\text{peak area of erythritol}} \times 100$$

sum of peak area of erythritol, glycerol, glycerol and
ribitol

$$\text{Glycerol (\%)} = \frac{\text{peak area of glycerol}}{\text{sum of peak area of erythritol, glycerol, glycerol and ribitol}} \times 100$$

(3) Lead : When 5.0 g of Erythritol is tested by Atomic Absorption Spectrophotometry or Inductively Coupled Plasma Emission Spectroscopy, its content should not be more than 0.5 ppm.

Loss on Drying When Erythritol is dried for 4 hours at 105°C, the weight loss should not be more than 0.2%.

Residue on Ignition When Residue on Ignition analysis is done with accurately weighted 2 g of Erythritol, the amount of Residue on Ignition should not be more than 0.1%.

Assay Approximately 2 g of dried Erythritol is precisely weighted and dissolved in water (total volume = 50 mL) (Test Solution). Separately, 2 g of dried erythritol standard is precisely weighted and dissolved in water (total volume = 50 mL) (Standard Solution). 10 μl each of Test and Standard Solutions are injected into liquid chromatography under the following Operation Conditions and the content of erythritol is obtained by the following equation.

$$\text{content(\%)} = \frac{\text{Weight of the standard(g)}}{\text{Weight of the sample(g)}} \times \frac{\text{peak area of test solution}}{\text{peak area of standard solution}} \times 100$$

Operation Conditions

- Detector : RI detector
- Column : MCI-CKO8SH, Shodex KC811 or its equivalent
- Column Temperature : 60°C
- Mobile Phase : Water
- Flow Rate : 1.0 mL/min

Ester Gum

INS No.: 445

Synonyms: Glycerol ester of wood rosin

CAS No.: 8050-30-4

Definition Ester Gum is esters of rosin or derivatives of rosins, such as polymerizates.

Compositional Specifications of Ester Gum

Description Ester Gum occurs as light yellow to light brown glassy lumps, or as a clear, viscous liquid. It is odorless or has a slightly characteristic odor.

Identification (1) To 1 g of Ester Gum, add 5 mL of sodium hydroxide solution and 5 mL of water, and shake vigorously. Light yellow turbidity appears, and effervescence persists.

(2) To 0.1 g of Ester Gum, add 10 mL of acetic Anhydrous, dissolve it by heating in a water bath, cool, and add 1 drop of sulfuric acid. A reddish violet color develops.

Purity (1) Clarity and Color of Solution : Weigh 10 g of Ester Gum, add 10 mL of toluene, dissolve it by warming to 70 ~ 75°C, filter while warming, and allow to stand for 24 hours. It should be clear.

(2) Acid Value : 3 g of Ester Gum is precisely weighed and dissolved in 50 mL of a 2:1 mixture of toluene and alcohol (neutralized with 0.1 N alcoholic solution of potassium hydroxide using phenolphthalein solution as an indicator). The solution is titrated with 0.1 N alcoholic solution of potassium hydroxide. Acid value of Ester Gum is proceeded under Acid Value in Fats Test and it should not be more than 8.

(3) Arsenic : It should be no more than 4.0 ppm tested by Arsenic Limit Test.

(4) Lead : When 5.0 g of Ester Gum is tested by Atomic Absorption Spectrophotometry or Inductively Coupled Plasma Emission Spectroscopy, its content should not be more than 2.0 ppm.

(5) Cadmium : When 5.0 g of Ester Gum is tested by Atomic Absorption Spectrophotometry or Inductively Coupled Plasma Emission Spectroscopy, its content should not be more than 1.0 ppm.

(6) Mercury : When Ester Gum is tested by Mercury Limit Test, its content should not be more than 1.0 ppm.

Residue on Ignition When thermogravimetric analysis is done with 1 g of Ester Gum, the residues should not be more than 0.1%.

Ethyl Acetate



Chemical Formula: $\text{C}_4\text{H}_8\text{O}_2$

Molecular Weight: 88.11

Synonyms: Acetic acid ethyl ether; Ethyl ethanoate

CAS No.: 141-78-6

Compositional Specifications of Ethyl Acetate

Content Ethyl Acetate should contain not less than 99.0% of ethyl acetate ($\text{C}_4\text{H}_8\text{O}_2$).

Description Ethyl Acetate is a colorless, transparent liquid having a fruity odor.

Identification (1) To 1 mL of Ethyl Acetate, add 5 mL of sodium hydroxide solution (1→4), and heat in a water bath while shaking. The fruity odor disappears. Acidify this solution with diluted sulfuric acid, and heat again in a water bath while shaking. An odor of acetic acid is evolved.

(2) To 1 mL of Ethyl Acetate, add 25 mL of sodium hydroxide solution, heat in a water bath for 5 minutes. Cool, neutralize with diluted hydrochloric acid, and add 5 drops of ferric chloride solution. A deep red color develops.

Purity (1) Specific Gravity : Specific gravity of Ethyl Acetate should be within a range of 0.897 ~ 0.906.

(2) Refractive Index : Refractive Index n_D^{20} of Ethyl Acetate should be within a range of 1.370 ~ 1.375

(3) Acid value : Weigh 20 g of Ethyl Acetate, and proceed as directed under Acid Value in Flavoring Substances Tests. The content should not be more than 0.1.

Assay Transfer 10 mL of ethanol into a 100-mL flask, and Accurately weigh. Add about 1 g of Ethyl Acetate to the above flask, and Accurately weigh again. Add 40 mL of 0.5 N alcoholic solution of potassium hydroxide, exactly measured, equip with a reflux condenser, heat in a water bath at $80 \pm 2^\circ\text{C}$ for 20 minutes. Cool, and titrate the excess alkali with 0.5 N hydrochloric acid (indicator : 2 ~ 3 drops of phenolphthalein solution). Perform a blank test in the same manner.

1 mL of 0.5 N alcoholic solution of potassium hydroxide = 44.06 mg of $\text{C}_4\text{H}_8\text{O}_2$

Ethyl Acetoacetate

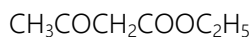

Chemical Formula: $\text{C}_6\text{H}_{10}\text{O}_3$

Molecular Weight: 130.14

Synonyms: Ethyl acetylacetate; Acetoacetic ester

CAS No.: 141-97-9

Compositional Specifications of Ethyl Acetoacetate

Content Ethyl Acetoacetate should contain not less than 97.5% of ethyl acetoacetate ($\text{C}_6\text{H}_{10}\text{O}_3$).

Description Ethyl Acetoacetate is a colorless, transparent liquid having a characteristic odor.

Identification (1) Dissolve 1 mL of Ethyl Acetoacetate in 3 mL of ethanol, and add 1 drop of ferric chloride solution. A purple-red color develops.

(2) To 0.5 mL of Ethyl Acetoacetate, add 5 mL of 10% alcoholic solution of potassium hydroxide, warm in hot water for 5 minutes, and cool. To the solution, add 10 mL of water and 2 mL of diluted hydrochloric acid. The solution responds to the test for Acetate (C) in Identification.

Purity (1) Specific Gravity : Specific gravity should be within a range of 1.022~1.027.

(2) Refractive Index : Refractive Index n_D^{20} should be within a range of 1.418~1.421.

(3) Clarity and Color of Solution : When 1 mL of Ethyl Acetoacetate is dissolved in 3 mL of 30% alcohol, the solution should be clear.

(4) Free Acid : Measure 15 mL of Ethyl Acetoacetate, add 15 mL of freshly boiled and cooled water, shake for 2 minutes, and allow to stand. Measure 10 mL of the water layer, and add 2 drops of phenolphthalein solution and 3.4 mL of 0.1 N potassium hydroxide. A pink color develops.

Assay Accurately weigh about 0.8 g of Ethyl Acetoacetate, and proceed as directed under Method 2 in Aldehyde and Ketone Content in Flavoring Substances Tests. In the procedure, allow the mixture to stand for 15 minutes.

0.5 N hydrochloric acid 1 mL = 65.07 mg of $\text{C}_6\text{H}_{10}\text{O}_3$

Ethyl Butyrate

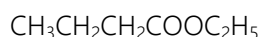

Chemical Formula: $\text{C}_6\text{H}_{12}\text{O}_2$

Molecular Weight: 116.16

Synonyms: Ethyl butanoate

CAS No.: 105-54-4

Compositional Specifications of Ethyl Butyrate

Content Ethyl Butyrate should contain not less than 98.0% of ethyl butyrate ($\text{C}_6\text{H}_{12}\text{O}_2$).

Description Ethyl Butyrate is a colorless to light yellow, transparent liquid having a fruity odor.

Identification To 1 mL of Ethyl Butyrate, add 5 mL of 10% alcoholic solution of potassium hydroxide. When this solution is shaken and heated in a water bath, its characteristic odor disappears. After cooling, this solution is acidified with dilute sulfuric acid, and an odor of butyric acid is generated.

Purity (1) Specific Gravity : Specific gravity of Ethyl Butyrate should be within a range of 0.870 ~ 0.877.
(2) Refractive Index : Refractive Index n_D^{20} of Ethyl Butyrate should be within a range of 1.391 ~ 1.394.
(3) Clarity and Color of Solution : When 1 mL of Ethyl Butyrate is dissolved in 3 mL of 60% ethanol, the solution should be clear.
(4) Acid Value : Acid value of Ethyl Butyrate is tested by Acid Value in Flavoring Substance Test. It should not be more than 1.

Assay Accurately weigh about 1 g of Ethyl Butyrate, and test by Ester Value in Flavoring Substances Test.

1 mL of 0.5 N alcoholic solution of potassium hydroxide = 58.08 mg $\text{C}_6\text{H}_{12}\text{O}_2$

Ethyl Cellulose

INS No.: 462

Synonyms: Modified cellulose; Ethyl ether of cellulose

CAS No.: 9004-57-3

Compositional Specifications of Ethyl Cellulose

Content Ethyl Cellulose, when calculated on the dried basis, should contain within a range of 44.0 ~ 50.0% of the ethoxyl functional ($-\text{OCH}_2\text{CH}_3$).

Description Ethyl Cellulose is a white to brown powder.

Identification (1) Ethyl Cellulose does not dissolved in propane-1,2-diol, and glycerol, but does dissolved in various ratios of organic solvents according to the content of ethoxyl functional. If the content of ethyl cellulose is not more than 46 ~ 48% of the ethoxyl functional, Ethyl Cellulose dissolves in aromatic hydrocarbon ethanol mixtures, methyl acetate, chloroform, or tetrahydrofuran. If the content is 46 ~ 48% or not less than of the ethoxyl functional, Ethyl Cellulose dissolves in ethanol, methanol, toluene, chloroform, or methyl acetate.

(2) If 5 g of Ethyl Cellulose is dissolved in 95 g of the toluene-ethanol mixture (80:20, W/W), the solution is clear and a pale yellow liquid is generated. If a small amount of this liquids taken and evaporated on a glass plate, a thick, infrangible, combustible, transparent film remains.

Purity (1) Arsenic : It should be no more than 4.0 ppm tested by Arsenic Limit Test.

(2) Lead: When 5.0 g of Ethyl Cellulose is tested by Atomic Absorption Spectrophotometry or Inductively Coupled Plasma Emission Spectroscopy, its content should not be more than 2.0 ppm.

(3) Cadmium : When 5.0 g of Ethyl Cellulose is tested by Atomic Absorption Spectrophotometry or Inductively Coupled Plasma Emission Spectroscopy, its content should not be more than 1.0 ppm.

(4) Mercury : When Ethyl Cellulose is tested by Mercury Limit Test, its content should not be more than 1.0 ppm.

(5) Viscosity : Those where the viscosity is marked to be not more than 10 cps are 80.0 ~ 120.0% of the marked amount, and those is marked to be not less than 10 cps are 90.0 ~ 110.0% of the marked amount. Ethyl cellulose that contains not more than 46 ~ 48% of the ethoxyl functional is prepared with the toluene-alcohol mixture (60:40, w/w) and ethyl cellulose that contain not less than 46 ~ 48% of the ethoxyl functional with the toluene-alcohol mixture (80:20, w/w) in the following test. 5.0 g of Ethyl cellulose is taken and dried previously at 105°C for 2 hours, and then the weight is measured. It is put with 95±5 g of a proper solvent in a bottle, which is shaken until it is completely dissolved. Its viscosity is measured at 25 ± 1°C.

Loss on Drying When Ethyl cellulose is dried at 105°C for 2 hours, the weight loss should not be more than 3%.

Residue on Ignition When 1 g of Ethyl cellulose is accurately weighed and strongly heated at 800 ± 25°C, the weight loss should not be more than 0.4%.

Assay About 50 mg of Ethyl cellulose is weighed and put in a 5 mL-vial equipped with a pressure tight septum closure, and 65 mg of adipic acid, 2.0 mL of the inner standard solution, and 2.0 mL of hydrogen iodide are added, the vial is stoppered, and its weight is then accurately measured. The bottle is shaken for 30 sec for mixing, and heated at 150°C for 20 minutes using a heater. Then the vials shaken for mixing again and heated for 40 minutes and cooled for 45 minutes, and the weight is again accurately measured. When the weight loss is not more than 10 mg, the supernatant is use the test solution. Separately, 65 mg of adipic acid, 2.0 mL of the inner standard solution, and 2.0 mL of hydrogen iodide are put in another pressure tight vial, which is then stoppered, and the weight is measured accurately. 15 µl of ethyl iodide is added and the weigh is measured again accurately. After the bottle is shaken for 30 sec, the supernatant is use the standard solution. 1 µl each of the test solutions and standard solutions is injected to gas chromatograph and the content of the ethoxyl functional is obtained using the following equation.

$$\text{content of the ethoxyl group (\%)} = \frac{Q_{Ta}}{Q_{Sa}} \times \frac{W_{Sa}}{\text{weight of the sample(mg)}} \times 28.89$$

W_{Sa} : Amount (mg) of ethyl iodide in the standard solution

Q_{Sa} : The ratio of the peak area of ethyl iodide to that of the inner standard material in the standard solution

Q_{Ta} : The ratio of the peak area of ethyl iodide to that of the inner standard material in the test solution

Operation Conditions

- Column : diatomaceous earth (Chromosorb WHP or its equivalent) for gas chromatography covered with 10% methyl silicon oil or its equivalent
- Detector : Thermal Conductivity Detector or Flame Ionization Detector
- Inlet Temperature : 200°C
- Column Temperature : 50°C
- Detector Temperature : 200°C
- Carrier Gas : Helium or nitrogen

• Inner Standard Solution : 0.25 g of toluene is weighed accurately and o-xylene is added to make 50 mL.

Ethyl Cinnamate



Chemical Formula: $C_{11}H_{12}O_2$

Molecular Weight: 176.21

Synonyms: Ethyl phenylacrylate

CAS No.: 103-36-6

Compositional Specifications of Ethyl Cinnamate

Content Ethyl Cinnamate should contain not less than 99.0% of ethyl cinnamate($C_{11}H_{12}O_2$).

Description Ethyl Cinnamate is a colorless to light yellow liquid having a characteristic odor.

Identification To 1 mL of Ethyl Cinnamate, add 10 mL of 10% alcoholic solution of sodium hydroxide, and proceed as directed under Identification in 「Methyl Cinnamate」.

Purity (1) Specific Gravity : Specific gravity of Ethyl Cinnamate should be within a range of 1.045 ~ 1.051

(2) Refractive Index : Refractive Index n_D^{20} of Ethyl Cinnamate should be within a range of 1.558 ~ 1.560

(3) Clarity and Color of Solution : When 1mL of Ethyl Cinnamate is dissolved in 5 mL of 70% ethanol, the solution should be clear.

(4) Acid Value : Acid value of Ethyl Cinnamate is tested by acid value in Flavoring Substance Test. It should not be more than 1.

Assay Accurately weigh 1 g of Ethyl Cinnamate tested by Ester Value and Ester Content in Flavoring Substances Test. In this case, 5 mL of water is added before heating.

1mL of 0.5 N alcoholic solution of potassium hydroxide = 88.11 mg $C_{11}H_{12}O_2$

Ethyl Decanoate

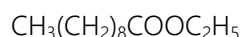

Chemical Formula: $\text{C}_{12}\text{H}_{24}\text{O}_2$

Molecular Weight: 200.32

Synonyms: Ethyl caprate

CAS No.: 110-38-3

Compositional Specifications of Ethyl Decanoate

Content Ethyl Decanoate should contain not less than 98.0% of ethyl decanoate ($\text{C}_{12}\text{H}_{24}\text{O}_2$).

Description Ethyl Decanoate is a colorless, transparent liquid having a characteristic scent.

Identification (1) To 1 mL of Ethyl Decanoate, add 5 mL of ethanolic 10% potassium hydroxide solution, equip with a reflux condenser, and heat in a water bath for 1 hour. The characteristic scent disappears. After cooling, the solution is acidified with diluted sulfuric acid and shaking in a warm water bath. A characteristic odor of decanoic acid is evolved.

(2) Dissolve 1 mL of Ethyl Decanoate in 1 mL of ethanol, add 0.4 g of hydrazine (hydrated), equip with a reflux condenser. and heat in a water bath for 3 hours. After cooling, collect the deposited crystalline lumps, wash with a small amount of ethanol, and recrystallize from ethanol. The melting point of Ethyl Decanoate should be approximately 98°C

Purity (1) Specific Gravity : Specific gravity of Ethyl Decanoate should be within a range of 0.863 ~ 0.868

(2) Refractive Index : Refractive Index n_D^{20} of Ethyl Decanoate should be within a range of 1.424 ~ 1.427

(3) Clarity and Color of Solution : When 1 mL of Ethyl Decanoate is dissolved in 4 mL of 80% ethanol, the solution should be clear.

(4) Acid Value : Acid value of Ethyl Decanoate is tested by Acid Value in Flavoring Substance Test. It should not be more than 1.

Assay Accurately weigh about 1 g of Ethyl Decanoate and proceed as directed under Ester Value and Ester Content in Flavoring Substance Test.

1 mL of 0.5 N alcoholic potassium hydroxide = 100.2 mg of $\text{C}_{12}\text{H}_{24}\text{O}_2$

Ethyl Heptanoate

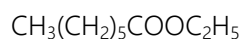

Chemical Formula: $\text{C}_9\text{H}_{18}\text{O}_2$

Molecular Weight: 158.24

Synonyms: Ethyl heptylate; Ethyl oenanthate

CAS No.: 106-30-9

Compositional Specifications of Ethyl Heptanoate

Content Ethyl Heptanoate contains no less than 98.0% of ethyl heptanoate ($\text{C}_9\text{H}_{18}\text{O}_2$).

Description Ethyl Heptanoate is a colorless to light yellow, transparent liquid having a wine-like odor.

Identification To 1 mL of Ethyl Heptanoate, add 5 mL of ethanolic 10% potassium hydroxide solution, and heat in a water bath while shaking. The wine-like odor disappears. Cool, and acidify with diluted sulfuric acid (1→20). An odor of heptanoic acid is evolved.

Purity (1) Specific Gravity : Specific gravity should be within a range of 0.869 ~ 0.874

(2) Refractive Index : Refractive Index n_D^{20} should be within a range of 1.411 ~ 1.416

(3) Clarity and Color of Solution : 1 mL of Ethyl Heptanoate dissolved in 5 mL of 70% v/v ethanol. This solution should be clear.

(4) Acid value : Acid value of Ethyl Heptanoate is tested by Acid Value in Flavoring Substance Test. It should not be more than 1.0.

Assay Accurately weigh about 0.8 g of Ethyl Heptanoate, and proceed as directed under Ester Value and Ester Content in Flavoring Substances Tests.

1 mL of 0.5 N alcoholic solution of potassium hydroxide = 79.12 mg of $\text{C}_9\text{H}_{18}\text{O}_2$

Ethyl Hexanoate

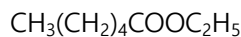

Chemical Formula: $\text{C}_8\text{H}_{16}\text{O}_2$

Molecular Weight: 144.21

Synonyms: Ethyl caproate; Capronic ether absolute

CAS No.: 123-66-0

Compositional Specifications of Ethyl Hexanoate

Content Ethyl Hexanoate should contain not less than 98.0% of ethyl hexanoate ($\text{C}_8\text{H}_{16}\text{O}_2$).

Description Ethyl Hexanoate is a colorless to light yellow, transparent liquid having a characteristic odor.

Identification To 1 mL of Ethyl Hexanoate, add 5 mL of 10% alcoholic potassium hydroxide solution, and heat in a water bath while shaking. The characteristic odor disappears. Cool, and acidify with diluted sulfuric acid. An odor of hexanoic acid is evolved.

Purity (1) Specific Gravity : Specific gravity of Ethyl Hexanoate should be within a range of 0.871 ~ 0.875.

(2) Refractive Index : Refractive Index n_D^{20} of Ethyl Hexanoate should be within a range of 1.406 ~ 1.409.

(3) Clarity and Color of Solution : When 1 mL of Ethyl Hexanoate is dissolved in 3 mL of 70% alcohol, the solution be clear.

(4) Acid value : Acid value of Ethyl Hexanoate is tested by Acid Value in Flavoring Substance Test. It should not be more than 1.

Assay Accurately weigh about 0.7 g of Ethyl Hexanoate, and proceed as directed under Ester Content in Flavoring Substances Tests.

1 mL of 0.5 N alcoholic solution of potassium hydroxide = 72.11 mg of $\text{C}_8\text{H}_{16}\text{O}_2$

Ethyl *p*-Hydroxybenzoate



Chemical Formula: C₉H₁₀O₃

Molecular Weight: 166.18

INS No.: 214

Synonyms: Ethyl *p*-oxybenzoate; Ethylparaben

CAS No.: 120-47-8

Compositional Specifications of Ethyl *p*-Hydroxybenzoate

Content Ethyl *p*-Hydroxybenzoate, when calculated on the dried basis, should contain not less than 99.0% of ethyl *p*-Hydroxybenzoate (C₉H₁₀O₃).

Description Ethyl *p*-Hydroxybenzoate occurs as colorless crystals or as a white crystalline powder. It is odorless.

Identification (1) To 0.5 g of Ethyl *p*-Hydroxybenzoate, add 10 mL of sodium hydroxide, boil about 30 minutes, evaporate to about 5 mL, and cool. Acidify this solution with diluted sulfuric acid and wash formed precipitates with water. Dry it for 1 hour at 105°C, and the melting point is 213 ~ 217°C.

(2) To 0.05 g of Ethyl *p*-Hydroxybenzoate, add 2 drops of acetic acid and 5 drops of sulfuric acid. After heating for 5 minutes, the solution generates a smell of ethyl acetate.

Purity (1) Melting Point : Melting point of Ethyl *p*-Hydroxybenzoate should be within a range of 115 ~ 118°C.

(2) Free Acids : To 0.75 g of Ethyl *p*-Hydroxybenzoate, add 15 mL of water and heat for 1 minutes in effervescent water bath and cool. The filtrate is acidic or neutral. To 10 mL of filtrate, 0.2 mL of 0.1N sodium hydroxide and 2 drops of methyl red solution are added. A yellow color develops.

(3) Sulfate : To 1 g of Ethyl *p*-Hydroxybenzoate, add 100 mL of hot water, mix by shaking, heat for 5 minutes and cool. Water is added to make 100 mL. To 40 mL of filtrate, 1 mL of diluted hydrochloric acid is added, test solution. When this test solution proceeds as directed under sulfate, its content should not be more than the amount that corresponds to 0.2 mL of 0.01 N sulfuric acid.

(4) Arsenic : It should be no more than 4.0 ppm tested by Arsenic Limit Test.

(5) Lead : When 5.0 g of Ethyl *p*-Hydroxybenzoate is tested by Atomic Absorption Spectrophotometry or Inductively Coupled Plasma Emission Spectroscopy, its content should not be more than 2.0 ppm.

(6) Mercury : When Ethyl *p*-Hydroxybenzoate is tested by Mercury Limit Test, its content should not be more than 1.0 ppm.

(7) *p*-Hydroxybenzoic Acid and Salicylic Acid : Accurately weigh 0.5g of Ethyl *p*-Hydroxybenzoate and dissolve in 30mL of ether and add 20 mL of Sodium hydrogen carbonate solution (1 in 100), shake and separate the water layer. Wash the water layer with two 20 mL portions of add 5 mL of dilute sulfuric acid and 30 mL of ether, and shake. Separate the ether layer, and shake with about 10 mL of

water. Filter the ether layer, and wash the vessel and the filter with a small amount of ether. Combine the washings and the filtrate, evaporate ether on a water bath, and dry the residue over sulfuric acid to constant weight. The weight of sulfuric acid to constant weight. The weight of the residue should not exceed 5mg. Dissolve any residue in 25mL of water, heat to 70°C, filter, and add a few drops of dilute ferric chloride TS. No violet to reddish violet colour should be produced.

Loss on Drying When Ethyl *p*-Hydroxybenzoate is dried for 2 hours at 80°C, the weight loss should not be more than 0.5%.

Residue on Ignition When thermogravimetric analysis is done with approximately 5 g of Ethyl *p*-Hydroxybenzoate, the amount of residues should not be more than 0.05%.

Assay To 2 g of Ethyl-*p*-Hydroxybenzoate, precisely weighed, add 40 mL of 1 N sodium hydroxide solution and boil for 30 minutes and cool. Titrate the excess alkali with 1 N sulfuric acid (indicator : 5 drops of bromthymol blue test solution). The color of end point is the color which appears by adding same indicator to buffer solution of pH 6.5. Separately, perform a blank test in the same manner.

1 mL of 1 N sodium hydroxide = 166.2 mg of $C_9H_{10}O_3$

Ethyl Isovalerate

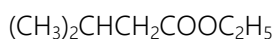

Chemical Formula: $\text{C}_7\text{H}_{14}\text{O}_2$

Molecular Weight: 130.19

Synonyms: Ethyl beta-methylbutyrate; Ethyl isopentanoate

CAS No.: 108-64-5

Compositional Specifications of Ethyl Isovalerate

Content Ethyl Isovalerate should contain not less than 98.0% of ethyl isovalerate ($\text{C}_7\text{H}_{14}\text{O}_2$).

Description Ethyl Isovalerate is a colorless to light yellow, transparent liquid having a characteristic odor.

Identification To 1 mL of Ethyl Isovalerate, add 5 mL of 10% alcoholic solution of potassium hydroxide, and heat in a water bath while shaking. The characteristic odor disappears. Cool, and acidify with diluted sulfuric acid. An odor of isovaleric acid is evolved.

Purity (1) Specific Gravity : Specific gravity of Ethyl Isovalerate should be within a range of 0.862 ~ 0.866.

(2) Refractive Index : Refractive Index n_D^{20} of Ethyl Isovalerate should be within a range of 1.395 ~ 1.399.

(3) Clarity and Color of Solution : When 2 mL of Ethyl Isovalerate is dissolved in 6 mL of 70% alcohol solution, it should be Clear.

(4) Acid Value : Acid value of Ethyl Isovalerate is tested by Acid Value in Flavoring Substance Test. It should not be more than 2.

Assay Accurately weigh 1.5 g of Ethyl Isovalerate, and proceed as directed under Ester value and Ester Content in Flavoring Substances Tests.

1 mL of 0.5 N ethanolic potassium hydroxide = 65.09 mg of $\text{C}_7\text{H}_{14}\text{O}_2$

Ethyl Octanoate

Ethyl Caprylate

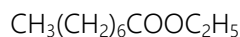

Chemical Formula: $\text{C}_{10}\text{H}_{20}\text{O}_2$

Molecular Weight: 172.27

Synonyms: Ethyl caprylate

CAS No.: 106-32-1

Compositional Specifications of Ethyl Octanoate

Content Ethyl Octanoate should contain not less than 98.0% of ethyl octanoate ($\text{C}_{10}\text{H}_{20}\text{O}_2$).

Description Ethyl Octanoate is a colorless or slightly yellowish, transparent liquid having a brandy-like odor.

Identification (1) To 1 mL of Ethyl Octanoate, add 5 mL of 10% alcoholic solution of potassium hydroxide, equip with a reflux condenser, and heat in a water bath for 30 minutes. The brandy-like odor disappears. Cool, and acidify with diluted sulfuric acid. An odor of octanoic acid is evolved.

(2) Dissolve 1 mL of Ethyl Octanoate in 1 mL of alcohol, add 0.4 g of hydrazine (hydrate), equip with a reflux condenser, and heat in a water bath for 3 hours. Cool, collect the deposited crystal lumps by filtration, wash with a small amount of alcohol, and recrystallize from alcohol. The melting point is 88°C.

Purity (1) Specific Gravity : Specific gravity of Ethyl Octanoate should be within a range of 0.865 ~ 0.869.

(2) Refractive Index : Refractive Index n_D^{20} of Ethyl Octanoate should be within a range of 1.417 ~ 1.419

(3) Clarity and Color of Solution : When 1 mL of Ethyl Octanoate is dissolved in 4 mL of 70% alcohol, the solution should be clear.

(4) Acid Value : Acid value of Ethyl Octanoate is tested by Acid Value in Flavoring Substance Test. It should not be more than 1.

Assay Accurately weigh about 1 g of Ethyl Octanoate, and proceed as directed under Ester Content in Flavoring Substances Tests.

1 mL of 0.5 N ethanolic potassium hydroxide = 86.13 mg of $\text{C}_{10}\text{H}_{20}\text{O}_2$

Ethyl Phenylacetate

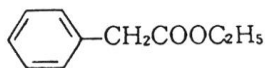

Chemical Formula: $C_{10}H_{12}O_2$

Molecular Weight: 164.20

Synonyms: Ethyl alpha-toluate

CAS No.: 101-97-3

Compositional Specifications of Ethyl Phenylacetate

Content Ethyl phenylacetate should contain not less than 98.0% of ethyl phenylacetate ($C_{10}H_{12}O_2$).

Description Ethyl phenylacetate is a colorless, transparent liquid having a characteristic odor.

Identification To 2 mL of Ethyl Phenylacetate, add 10 mL of 10% potassium hydroxide solution, equip with a reflux condenser, and boil gently for 1 hour. The characteristic odor disappears. Distill the solution, and remove about 4 mL of the initial distillate. Acidify the residual solution with diluted hydrochloric acid and cool. Crystals are deposited. Collect the crystals by filtration, wash with water, and recrystallize from boiling water. The melting point is approximately $76^{\circ}C$.

Purity (1) Specific Gravity : Specific gravity of Ethyl Phenylacetate should be within a range of 1.027 ~ 1.032.

(2) Refractive Index : Refractive Index n_D^{20} of Ethyl Phenylacetate should be within a range of 1.496 ~ 1.500.

(3) Clarity and Color of Solution : When 1 mL of Ethyl Phenylacetate is dissolved in 2 mL of 70% alcohol, the solution should be clear.

(4) Acid Value : Acid value of Ethyl Phenylacetate is proceeded as directed under Acid Value in Flavoring Substance Test. It should not be more than 1.

(5) Chlorinated Compounds : When Ethyl Phenylacetate is proceeded as directed under Copper Mesh Test Method in Halogenated Compounds for Flavoring, it should be appropriate.

Assay Accurately weigh about 1 g of Ethyl Phenylacetate, and proceed as directed under Ester Value and Ester Content in Flavoring Substances Tests.

1 mL of 0.5 N alcoholic solution of potassium hydroxide = 82.10 mg of $C_{10}H_{12}O_2$

Ethyl Propionate

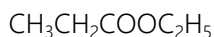

Chemical Formula: $\text{C}_5\text{H}_{10}\text{O}_2$

Molecular Weight: 102.13

Synonyms: Propionic ether

CAS No.: 105-37-3

Compositional Specifications of Ethyl Propionate

Content Ethyl Propionate should contain not less than 97.0% of ethyl propionate ($\text{C}_5\text{H}_{10}\text{O}_2$).

Description Ethyl Propionate is a colorless, transparent liquid having a characteristic odor.

Identification To 1 mL of Ethyl Propionate, add 5 mL of 10% ethanolic potassium hydroxide solution, and heat in hot water. The characteristic odor disappears. Cool, and acidify with diluted sulfuric acid. An odor of propionic acid is evolved.

Purity (1) Specific Gravity : Specific gravity of Ethyl Propionate should be within a range of 0.890 ~ 0.893.

(2) Refractive Index : Refractive Index n_D^{20} of Ethyl Propionate should be within a range of 1.383 ~ 1.385.

(3) Clarity and Color of Solution : 1 mL of Ethyl Propionate is dissolved in 3 mL of 50% ethanol. This solution should be Clear.

(4) Acid Value : Acid value of Ethyl Propionate is tested by Acid Value in Flavoring Substance Test. It should not be more than 2.

Assay Accurately weigh about 1 g of Ethyl Propionate, and proceed as directed under Ester Value and Ester Content in Flavoring Substances Tests.

1 mL of 0.5 N alcoholic solution of potassium hydroxide = 51.07 mg of $\text{C}_5\text{H}_{10}\text{O}_2$

Ethyl vanillin



Chemical Formula: $C_9H_{10}O_3$

Molecular Weight: 166.18

other names: Bourbonal; Ethyl portal

CAS No.: 121-32-4

Compositional Specifications of Ethyl vanillin

Content Ethyl vanillin should contain within a range of 98.0 ~ 101.0% of Ethyl vanillin($C_9H_{10}O_3$).

Description Ethyl vanillin occurs as white to light yellow, flaky crystals or crystalline powder, having a vanilla-like odor and taste.

Identification (1) To 0.1 g of Ethyl vanillin, add 1 mL of 25% hydrochloric acid, heat in a water bath for 5 minutes, cool, add 1 mL of hydrogen peroxide solution, shake well for 3 minutes, allow to stand until a precipitate is formed, add 2 mL of chloroform, and shake. The color of the chloroform layer changes to deep blue.

(2) Proceed as directed under Identification (2) in 「Vanillin」.

Purity (1) Melting Point : Melting point of Ethyl vanillin should be within a range of 76 ~ 78°C.

(2) Clarity and Color of Solution : When 1g of Ethyl vanillin is dissolved in 10 mL of 60% alcohol, the solution should be clear.

(3) Arsenic : It should be no more than 4.0 ppm tested by Arsenic Limit Test.

(4) Lead : When 5.0 g of Ethyl vanillin is tested by Atomic Absorption Spectrophotometry or Inductively Coupled Plasma Emission Spectroscopy, its content should not be more than 2.0 ppm.

Loss on Drying Ethyl vanillin is dried for 4 hours in a vacuum desiccator(silica gel) and the weight loss should not be more than 0.5%.

Residue on Ignition When thermogravimetric analysis is done with Ethyl vanillin, the residues should not be more than 0.05%.

Assay Accurately weigh about 1 g of Ethyl vanillin, and proceed as directed under Method 2 in Aldehyde and Ketone Content in Flavoring Substances Tests. In the procedure, allow the mixture to stand for 15 minutes.

1 mL of 0.5 N hydrochloric acid = 83.09 mg of $C_9H_{10}O_3$

Eucalyptol



Chemical Formula: $C_{10}H_{18}O$

Molecular Weight: 154.25

Other names: 1,8-Cineol

CAS No.: 470-82-6

Compositional Specifications of Eucalyptol

Content Eucalyptol should contain not less than 85.0% 1,8-cineol ($C_{10}H_{18}O$).

Description Eucalyptol is transparent colorless ~ pale yellow liquid with characteristic scent and refreshing taste.

Identification To 3 g of Eucalyptol, add melted 2 g of o-cresol by heating and mix by shaking. Then it turns into crystalline lump, which melts upon heating in a water bath.

Purity (1) Specific Gravity: Specific gravity of Eucalyptol should be within a range of 0.921~0.924.

(2) Optical Rotation : Optical rotation of Eucalyptol should be within a range of $[\alpha]_D^{25} = -0.5 \sim +0.5^\circ$.

(3) Refractive Index : Refractive Index, n_D^{20} of Eucalyptol should be within a range of 1.455~1.460.

(4) Clarity and Color of Solution : Dissolve 1 mL of Eucalyptol in 5 mL of 60% alcohol. This solution should be clear.

(5) Resorcin : 1 mL of Eucalyptol is well mixed with 5 mL of water and 1 drop of a mixture (1 mL of mercury (II) nitrate and 3 mL of water). While shaking, the mixture is heated for 2 minutes in a water bath. After cooling, 1 drop of dilute sulfuric acid and 1 drop of sodium nitrite solution are added, which is then heated again for 2 hours in a water bath. The aqueous layer should not turn yellow ~ yellowish brown.

(6) Phenanthrene : 2.5 mL of Eucalyptol is added to 5 mL of hexane. To this solution, 10 mL of sodium nitrite solution (1→20) is added and then 5 mL of glacial acetic acid is slowly added. Solution should not show crystallization within 10 minutes.

Assay 3 g of Eucalyptol and 2.1 g of heat-melted o-cresol are added into a test tube (A) with approximately 15 mm diameter and 80 ~ 160 mm length. A thermometer (B) is fixed with a cork stopper so that the mercury filling is slightly lower than the center of the liquid. While stirring the liquid with the thermometer, a temperature where crystallites start to form. A is heated so that the content is completely melted. A is transferred to a bottle (D) with a cork stopper (C) and slowly cooled. When

crystallites start to form again or the first recorded temperature is reached, the thermometer is vigorously rubbed against the inner wall of the tube, which lowers the temperature slightly. Then the temperature becomes constant, the temperature is recorded. This procedure is repeated and the highest temperature is taken and the content of eucalyptol is calculated from the table below.

Content of Eucalyptol (%)



온도	0.0	0.1	0.2	0.3	0.4	0.5	0.6	0.7	0.8	0.9
47	80.0	80.2	80.4	80.6	80.8	81.1	81.3	81.5	81.7	81.9
48	82.1	82.3	82.5	82.7	82.9	83.2	83.4	83.6	83.8	84.0
49	84.2	84.4	84.6	84.8	85.0	85.3	85.5	85.7	85.9	86.0
50	86.3	86.6	86.8	87.1	87.3	87.6	87.8	88.1	88.3	88.6
51	88.8	89.1	89.3	89.6	89.8	90.1	90.3	90.6	90.8	91.1
52	91.3	91.6	91.8	92.1	92.3	92.6	92.8	93.1	93.3	93.6
53	93.8	94.1	94.3	94.6	94.8	95.1	95.3	95.6	95.8	96.1
54	96.3	96.6	96.9	97.2	97.5	97.8	98.1	98.4	98.7	99.0
55	99.3	99.7	100.0							

Eugenol



Chemical Formula: $C_{10}H_{12}O_2$

Molecular Weight: 164.20

Other names: 4-Allylguaiacol

CAS No.: 97-53-0

Compositional Specifications of Eugenol

Content Eugenol should contain not less than 100.0% of eugenol ($C_{10}H_{12}O_2$).

Description Eugenol is a colorless to light yellow-brown, transparent liquid having a characteristic odor.

Identification (1) 5 drops of Eugenol is dissolved in 10 mL of water. When 3 drops of ferrous chloride solution are added to this solution, bluish green color appears.

(2) To 0.5 g of Eugenol, add 0.1 g of picric acid, 1 mL of acetone, and 9 mL of petroleum ether and heated until crystals dissolve, the solution becomes orange yellow.

Purity (1) Specific Gravity : Specific gravity of Eugenol should be within a range of 1.064 ~ 1.070.

(2) Refractive Index : Refractive Index n_D^{20} of Eugenol should be within a range of 1.540 ~ 1.542.

(3) Clarity and Color of Solution : When 2 mL of Eugenol is dissolved in 4 mL of 70% alcohol, the solution should be clear.

Assay Proceed as directed under Phenol Content in Flavoring Substances Tests. Instead of allowing to stand for 30 minutes, heat in a water bath for 30 minutes, and allow to cool to room temperature.

Exo-maltotetrahydrolase (G4 Producing Enzyme)

1,4- α -D-Glucan Maltotetrahydrolase

Definition Exomaltotetrahydrolase is an enzyme obtained from a culture of *Pseudomonas stutzeri*. Dilutant or stabilizer can be added for the purpose of activity adjustment and quality preservation.

Compositional Specifications of Exomaltotetrahydrolase (G4 Producing Enzyme)

Description Exomaltotetrahydrolase is white ~ dark brown powder, particle, paste or colorless ~ dark brown liquid.

Identification When Exomaltotetrahydrolase is proceeded as directed under Activity Test, it should have the activity as Exomaltotetrahydrolase.

Purity (1) Arsenic : It should be no more than 4.0 ppm tested by Arsenic Limit Test.

(2) Lead : When 5.0 g of Exomaltotetrahydrolase is tested by Atomic Absorption Spectrophotometry or Inductively Coupled Plasma Emission Spectroscopy, its content should not be more than 5.0 ppm.

(3) Coliform Group : When Exomaltotetrahydrolase proceed as directed under Microbiological Methods for Coliform Group in General Testing Methods in 「Standards and Specifications for Foods」, it should not contain more than 30 per 1 g of this product.

(4) Salmonella : When Exomaltotetrahydrolase proceed as directed under Microbiological Methods for Salmonella in General Testing Methods in 「Standards and Specifications for Foods」, it should be negative (-).

(5) E. Coli : When Exomaltotetrahydrolase is tested by Microbe Test Methods for E. Coli in General Test Method 「Standards and Specifications for Foods」, it should be negative (-).

Activity Test (activity)

◦Preparation of Test Solution : sample is diluted with calcium chloride acetic acid buffer solution (pH 6.0) so that 1 mL of the solution contains 0.5~0.9 Unit.

◦Test Procedure : 0.5 mL of substrate solution and 0.4 mL of calcium chloride acetic acid buffer solution (pH 6.0) are placed in a 25 mL volumetric flask, which is isothermalized for 15 minutes in a $40 \pm 0.1^\circ\text{C}$ water bath. Exactly 0.1 mL of Test Solution is added to the solution, mixed well by shaking, and set aside in a water bath. After exactly 15 minutes, 2 mL of alkaline copper solution is added to the solution, which is sealed and heated for exactly 20 minutes in a boiling water bath. Cool the solution immediately. 2 mL of arsenic-ammonium molybdate solution is added to this solution and well mixed until red precipitates of copper suboxide are completely dissolved. After setting aside for 20 minutes at room temperature, water is added to bring the total volume to 25 mL. Using water as a reference, the absorption (A_s) is measured at 520 nm with 1cm path length. Separately, perform a blank test by adding 0.5 mL of substrate solution, 0.4 mL of calcium chloride acetate buffer solution (pH 6.0), 2 mL of alkaline copper solution, and 0.1 mL of Test Solution and well mixing. Its absorption (A_B) is measured following the same procedure as the Test Solution.

Standard Curve

Glucose is dried for 6 hours at 105°C. 1.0 g of dried glucose is precisely weighted and dissolved in water (total volume = 100 mL). 1.0 mL, 2.0 mL, 3.0 mL, and 4.0 mL each of this solution is diluted to 100 mL with water. 1 mL of the each resulting solution contains 100 µg, 200 µg, 300 µg, and 400 µg of glucose. 1 mL of each glucose standard solution is placed in a 25 mL volumetric flask, where 2 mL of alkaline copper solution is added and well mixed. It is sealed, heated in a boiling water bath for exactly 20 minutes, and cooled immediately. 2 mL of arsenic-ammonium molybdate solution is added and well mixed until red precipitates of copper suboxide are completely dissolved. After setting aside for 20 minutes at room temperature, water is added to bring the total volume to 25 mL. Using water as a reference instead of the standard solution, the absorption of each standard solution is measured at 520 nm with 1cm path length. A standard curve of absorption versus the amount of glucose (µg) is prepared.

Enzyme activity is calculated by the following equation.

$$\text{(G4 Producing Enzyme) unit/g} = \{(A_s - A_B)\} \times F \times \frac{1}{15} \times \frac{1.0}{0.1} \times \frac{1}{180} \times \frac{N}{W}$$

F : Amount of glucose (µg) when the difference in absorption is 1.0 (obtained from the standard curve).

15 : Reaction time (minutes)

180 : Molecular weight of glucose

N : Dilution factor of test solution

W : Weight of sample(g)

Definition of Activity : 1G4 producing enzyme unit is an amount of enzyme that produces reducing sugar that corresponds to 1 µmol of glucose per minute under the conditions above.

Solutions

- Substrate Solution : 1.0 g of soluble starch (Lintner) is dispersed in 50 mL of water, where 50 mL of boiling water is slowly added while stirring. It is then boiled for 1 ~ 2 minutes. After cooling water is added to bring the total volume to 100 mL.
- Alkaline Copper Solution : 24.0 g of anhydrous sodium carbonate and 12.0 g of potassium sodium tartrate are dissolved in 200 mL of water. Separately, 18.0 g of sodium carbonate and 150 mL of water are added to a solution of 4.0 g copper sulfate in 50 mL of water and dissolved by heating. Cool the solution, and this solution is mixed with the previous solution. The total volume is brought up to 1,000 mL with water. The resulting solution is boiled for 10 minutes, which is set aside for 1 week and filtered through a glass filter.

- Arsenic · Ammonium Molybdate Solution : 3 g of sodium arsenate, dibasic (7 hydrate) is dissolved in 25 mL of water. 25 g of ammonium molybdate (4 hydrate) is dissolved in 450 mL of water, where 21 mL of sulfuric acid is added. Sodium arsenate, dibasic solution is slowly added to ammonium molybdate solution while stirring. It is set aside for 24 hours at 37°C. It is stored in a brown bottle.
- Calcium Chloride Acetate Buffer Solution (pH 6.0) : Prepare 0.1 M acetic acid and 0.1 M sodium acetate solution contained separately 5 mM calcium chloride. These two solutions are adjusted pH 6.0.

Storage Standards of Exomaltotetrahydrolase (G4 Producing Enzyme)

Exomaltotetrahydrolase is strongly hygroscopic. Store in a cold dark place and well-closed containers.

Ferric Ammonium Citrate

INS No.: 381

Synonyms: Ammonium iron citrate

CAS No.: 1185-57-5

Compositional Specifications of Ferric Ammonium Citrate

Content Ferric Ammonium Citrate should contain within a range of 14.5 ~ 21.0% of iron (Fe= 55.85).

Description Ferric Ammonium Citrate occurs as green, red-brown, deep red, brown, or brownish yellow, transparent flaky crystals. powder, granules, or lumps. it is odorless or has a slight odor of ammonia and a weak iron taste.

Identification (1) To 5 mL of ferric ammonium citrate solution (1→10), add 5 mL of sodium hydroxide solution, and heat. An odor of ammonia is evolved, and a red-brown precipitate is formed.

(2) To Ferric Ammonium Citrate solution (1→100), add an ammonia solution. A black color develops, and no precipitate is formed.

(3) To 5 mL of Ferric Ammonium Citrate solution (1→100), add 0.3 mL of potassium permanganate solution and 4 mL of mercury II sulfate solution, and boil. A white precipitate is formed.

(4) To 10 mL of Ferric Ammonium Citrate solution (1→10), add 4 mL of potassium hydroxide solution, and heat, and filter. Take 4 mL of filtrate, add acetic acid to make it slightly acidic, and cool. 2 mL of calcium chloride solution is added to the resulting solution, and boil. A white crystalline precipitate is slowly formed.

Purity (1) Sulfate : 0.4 g of Ferric Ammonium Citrate is dissolved in 50 mL of water, and make to 100 mL with water. 10 mL of this solution is boiled with 1 mL of dilute hydrochloric acid (1→4) and 0.1 g of hydroxylamine hydrochloride for 1 min. After cooling, the solution make to 50 mL with water, Test Solution. This Test Solution is tested by Sulfate Limit Test. Separately, a color standard solution is prepared by adding 1 mL of hydrochloric acid (1→4) and water to 0.4 mL of 0.01 N sulfuric acid, and make to 50 mL with water.

(2) Arsenic : It should be no more than 4.0 ppm tested by Arsenic Limit Test.

(3) Lead : When 5.0 g of Ferric Ammonium Citrate is tested by Atomic Absorption Spectrophotometry or Inductively Coupled Plasma Emission Spectroscopy, its content should not be more than 2.0 ppm.

(4) Mercury : When Ferric Ammonium Citrate is tested by Mercury Limit Test, its content should not be more than 1.0 ppm.

(5) Ferric Citrate : When add 1 drop of potassium ferrocyanide solution to 10 mL of Ferric Ammonium Citrate solution (1→ no blue precipitate is formed).

Assay Accurately weigh about 1 g of Ferric Ammonium Citrate, transfer into a flask with a ground-glass stopper, dissolve in 25 mL of water, and add 5 mL of hydrochloric acid and 4 g of potassium iodide.

The flask with a ground-glass stopper is placed on the flask, which is set-aside for 15 minutes in a dark place. 100 mL of water is added to the solution and the free iodine is titrated with 0.1 N sodium thiosulfate (indicator : starch solution). Separately, a blank test is carried out by the same procedure.

1 mL of 0.1 N potassium thiosulfate = 5.585 mg of Fe

Ferric Chloride

Chemical Formula: $\text{FeCl}_3 \cdot 6\text{H}_2\text{O}$

Molecular Weight: 270.30

CAS No.: 7705-08-0

Compositional Specifications of Ferric Chloride

Content Ferric Chloride should contain within a range of 98.5 ~ 102.0% of Ferric Chloride ($\text{FeCl}_3 \cdot 6\text{H}_2\text{O}$).

Description Ferric Chloride occurs as yellowish brown crystals or lumps with hygroscopic properties.

Identification Ferric Chloride responds to the tests by Chloride Limit Test and Ferric salts.

Purity (1) Clarity and Color of Solution: 1 g of Ferric Chloride is dissolved with 10 mL of hydrochloric acid (1→100) through heating. The turbidity of resulting solution should show slightly low level of turbid or better.

(2) Free acid: 2 g of Ferric Chloride is dissolve with 5 mL of water. There is no sign of vapor when glass rod dipped with ammonia is brought near to this solution.

(3) Nitrate: 5 g of Ferric Chloride is dissolve in 25 mL of water and heated to boil. Then 25 mL of ammonia is added. After cooling, mark this mixture to 100 mL with water and filter. Consider the filtrate as the test solution. Add 5mL of water, 0.1 mL of Indigocarmine, and 10mL of sulfuric acid to 5 mL of test solution. The solution should remain blue more than 5 minutes.

(4) Sulfate: Add 3mL of anhydrous sodium carbonate solution (1→8) to 20mL of test solution (3) and evaporate to dryness in the steam bath. Heat the content with a low flame of burner until there is no sign of the white vapor. After cooling, add 10mL of water and 3mL of hydrochloric acid (1→4) to the content and evaporate to dryness it in the steam bath. Dissolve the content with 0.3mL of hydrochloric acid (1->4) and water. Make 50mL of solution with water and tested by Sulfate Limit Test. Its content should not be more than the amount that corresponds to 0.4 mL of 0.01 N sulfuric acid.

(5) Lead : 1.0 g of Ferric Chloride is weighed and transferred into 50 mL flask. Add 10 mL of 9 N hydrochloric acid, 10 mL of water, 20 mL of ascorbic acid-sodium iodide solution and 5 mL of trioctyl phosphine oxide solution and shake it to mix for 30 seconds. Add keep it to separate the layer and again add water so that organic layer reaches to neck part of flask. After shaking to mix it, keep it to separate the layer. This organic solvent layer is used as test solution. Separately, take 10 mL of lead standard solution and make it precisely to 100 mL. Take 2 mL of this solution and transfer into 50 mL flask. And operate under condition as test solution method, this solution is used as reference solution. When it is tested by Atomic Absorption Spectrophotometry or Inductively Coupled Plasma Emission Spectroscopy, absorbance(luminous intensity) of test solution should not be more than absorbance(luminous intensity) of reference solution.(not be more than 2.0 ppm.)

Ascorbic acid-sodium iodide solution : 10 g of ascorbic acid and 19.3 g sodium iodide are dissolved

in water to make to 100 mL.

Trioctyl phosphine oxide solution : 5 g of trioctyl phosphine oxide is dissolved in methyl isobutyl ketone to make to 100 mL.

(6) Zinc: 20 mL of the test solution prepared in (3) above is neutralized by hydrochloric acid and then make 30mL with water. Add 3 mL of diluted hydrochloric acid and 0.2 mL of potassium ferrocyanide (1→10), and allow to stand for 15 minutes. The solution should not be more turbid than the following reference solution. To prepare reference solution, measure 3mL of zinc standard solution, and add water to make 30mL. Add 3mL of diluted hydrochloric acid and 0.2 mL of potassium ferrocyanide (1→10) to this solution, and allow to stand 15 minutes. (not more than 30 ppm as Zinc)

(7) Arsenic: It should be no more than 4.0 ppm tested by Arsenic Limit Test.

(8) Free chloride: 2g of Ferric Chloride is dissolved in 5 mL of water. After heating, the filter paper treated with the starch iodide zinc solution should not turn blue.

Assay 0.6 g of Ferric Chloride is precisely weighed and transferred into a flask with a ground-glass stopper along with 50 mL of water as a solvent. 3 mL of hydrochloric acid and 3g of potassium iodide are added. The stopper is placed on the flask, which is set-aside for 15 minutes in a dark place. Then the contents are titrated with 0.1N sodium thiosulfate solution (indicator: starch solution). Separately, a blank test is carried out by the same procedure.

1 mL of 0.1 N sodium thiosulfate = 27.030mg $\text{FeCl}_3 \cdot 6\text{H}_2\text{O}$

Ferric Citrate

Chemical Formula: $\text{FeC}_6\text{H}_5\text{O}_7 \cdot x\text{H}_2\text{O}$

Molecular Weight: 244.95(anhydrous)

Compositional Specifications of Ferric Citrate

Content Ferric Citrate should contain within a range of 16.5 ~ 18.5 % of iron (Fe = 55.85).

Description Ferric Citrate occurs as transparent reddish crystalline platelets or as brown powder.

Identification Ferric Citrate responds to the test for Citrate (A) and Ferric Salt in Identification.

Purity (1) Clarity and Color of Solution : When 1 g of Ferric Citrate is dissolved in 20 mL of water by heating in a water bath, the solution should be almost clear.

(2) Ammonium Salt : When 1 g of Ferric Citrate is boiled in 10 mL of water and 5 mL of calcium hydroxide solution, it should not generate an odor of ammonia.

(3) Sulfate : 0.4 g of Ferric Citrate is dissolved in 50 mL of water, and make to 100 mL with water. 10 mL of this solution is boiled with 1 mL of dilute hydrochloric acid (1→4) and 0.1 g of hydroxylamine hydrochloride for 1 min. After cooling, the solution make to 50 mL with water, Test Solution. This Test Solution is tested by Sulfate Limit Test. Separately, a color standard solution is prepared by adding 1 mL of hydrochloric acid (1→4) and water to 0.4 mL of 0.01 N sulfuric acid, and make to 50 mL with water.

(4) Arsenic : It should be no more than 4.0 ppm tested by Arsenic Limit Test.

(5) Lead : When 5.0 g of Ferric Citrate is tested by Atomic Absorption Spectrophotometry or Inductively Coupled Plasma Emission Spectroscopy, its content should not be more than 2.0 ppm.

Assay Transfer about 1 g of Ferric Citrate accurately weighed into a flask with a ground-glass stopper, and 5 mL of hydrochloric acid and 30 mL of water are added. It is dissolved by heating. After cooling, 4 g of potassium iodide is added. The flask with a ground-glass stopper is placed on the flask, which is set-aside for 15 minutes in a dark place. 100 mL of water is added to the solution and the free iodine is titrated with 0.1 N sodium thiosulfate (indicator: starch solution). Separately, a blank test is carried out by the same procedure.

1 mL of 0.1 N sodium thiosulfate = 5.585 mg of Fe

Ferric Phosphate

Chemical Formula: $\text{FePO}_4 \cdot n\text{H}_2\text{O}$

Molecular Weight: anhydrous 150.82

CAS No.: 10045-86-0

Compositional Specifications of Ferric Phosphate

Content Ferric Phosphate should contain within a range of 26.0~32.0% of iron(Fe).

Description Ferric Phosphate is pale yellow powder and odorless.

Identification 1 g of Ferric Phosphate is dissolved in 5 mL of diluted hydrochloric acid (1→2). Upon adding excess sodium hydroxide solution, reddish brown precipitates are formed. This is then heated and filtered to separate iron. The filtrate is acidified with hydrochloric acid and cooled, where the same volume of magnesia solution is added. When slight excess amount of ammonia solution is added to the resulting solution, white precipitates are formed. The precipitates are washed with water. Upon adding a few drops of silver nitrate solution, the precipitates turn yellowish green.

Purity (1) Arsenic : It should be no more than 4.0 ppm tested by Arsenic Limit Test.

(2) Lead : 1.0 g of Ferric Phosphate is weighed and transferred into 50 mL flask. Add 10 mL of 9 N hydrochloric acid, 10 mL of water, 20 mL of ascorbic acid-sodium iodide solution and 5 mL of trioctyl phosphine oxide solution and shake it to mix for 30 seconds. Add keep it to separate the layer and again add water so that organic layer reaches to neck part of flask. After shaking to mix it, keep it to separate the layer. This organic solvent layer is used as test solution. Separately, take 10 mL of lead standard solution and make it precisely to 100 mL. Take 2 mL of this solution and transfer into 50 mL flask. And operate under condition as test solution method, this solution is used as reference solution. When it is tested by Atomic Absorption Spectrophotometry or Inductively Coupled Plasma Emission Spectroscopy, absorbance(luminous intensity) of test solution should not be more than absorbance(luminous intensity) of reference solution.(not be more than 2.0 ppm.)

Ascorbic acid-sodium iodide solution : 10 g of ascorbic acid and 19.3 g sodium iodide are dissolved in water to make to 100 mL.

Trioctyl phosphine oxide solution : 5 g of trioctyl phosphine oxide is dissolved in methyl isobutyl ketone to make to 100 mL.

(3) Mercury : Proceed as directed under Purity (4) in [Reduced Iron]. 3 mL of mercury standard solution (for Reduced Iron) is tested by the same procedure as the test solution. (Not more than 3 ppm)

Loss on Ignition When thermogravimetric analysis is done at 800°C for 1 hour, weight loss should not be more than 32.5%.

Assay 3.5 g of Ferric Phosphate is dissolved in 75 mL of diluted hydrochloric acid (1→2), which is then boiled for 5 minutes. After cooling, the solution is diluted to 100 mL with diluted hydrochloric acid

(1→2). This is again boiled for 5 minutes. While stirring, stannous chloride solution is drop-wise added to the resulting solution until iron is reduced and yellow color disappears. 2 drops of stannous chloride solution and approximately 50 mL of water are added. After cooling to room temperature, and add 15 mL of saturated mercury chloride solution and then stirring vigorously. This solution allow to stand for 5 minutes and 15 mL of a mixture of sulfuric acid and phosphoric acid (75 mL of sulfuric acid is slowly added to 300 mL of water. After cooling, 75 mL of phosphoric acid and water to make 500 mL). After adding 0.5 mL of barium diphenylamine sulfonate solution, the solution is titrated with 0.1 N potassium bichromate solution until it turns reddish purple.

1 mL of 0.1 N Potassium bichromate = 5.585 mg Fe

Ferric Pyrophosphate

Chemical Formula: $\text{Fe}_4(\text{P}_2\text{O}_7)_3 \cdot n\text{H}_2\text{O}$

Molecular Weight: 745.22(anhydrous로서)

Synonyms: Iron pyrophosphate

CAS No.: 10058-44-3

Compositional Specifications of Ferric Pyrophosphate

Content Ferric Pyrophosphate should contain within a range of 24.0 ~ 26.0% of iron(Fe).

Description Ferric Pyrophosphate occurs as a yellow to yellow-brown powder. It is odorless.

Identification When an excess amount of sodium hydroxide solution is added to a solution 0.5 g of Ferric Pyrophosphate in 5 mL of dilute hydrochloric acid (1→2), reddish brown precipitates are formed. After settling for several minutes, it is filtered. The first filtrate is discarded. 1 drop of bromine phenol blue solution is added to 5 mL of clear solution. It is then titrated with 1 N hydrochloric acid until it becomes green. When 10 mL of zinc sulfate solution (1→8) is added to the resulting solution and its pH is adjusted to 3.8, white precipitates are formed.

Purity (1) Arsenic : It should be no more than 4.0 ppm tested by Arsenic Limit Test.

(2) Lead : 1.0 g of Ferric Pyrophosphate is weighed and transferred into 50 mL flask. Add 10 mL of 9 N hydrochloric acid, 10 mL of water, 20 mL of ascorbic acid-sodium iodide solution and 5 mL of trioctyl phosphine oxide solution and shake it to mix for 30 seconds. Add keep it to separate the layer and again add water so that organic layer reaches to neck part of flask. After shaking to mix it, keep it to separate the layer. This organic solvent layer is used as test solution. Separately, take 10 mL of lead standard solution and make it precisely to 100 mL. Take 2 mL of this solution and transfer into 50 mL flask. And operate under condition as test solution method, this solution is used as reference solution. When it is tested by Atomic Absorption Spectrophotometry or Inductively Coupled Plasma Emission Spectroscopy, absorbance(luminous intensity) of test solution should not be more than absorbance(luminous intensity) of reference solution.(not be more than 2.0 ppm.)

Ascorbic acid-sodium iodide solution : 10 g of ascorbic acid and 19.3 g sodium iodide are dissolved in water to make to 100 mL.

Trioctyl phosphine oxide solution : 5 g of trioctyl phosphine oxide is dissolved in methyl isobutyl ketone to make to 100 mL.

(3) Mercury : Proceed as directed under Purity (4) in [Reducing Iron]. In this case, 3 mL of iron standard solution (for reducing iron) is used and the same procedure is Test Solution is followed (Not more than 3 ppm).

Loss on Ignition When Ferric Pyrophosphate is heat treated for 1 hour at 800°C, the weight loss should not be more than 20.0%.

Assay 3.5 g of Ferric Pyrophosphate is precisely weighed and dissolved in 75 mL of dilute hydrochloric acid (1→2), which is then boiled for 5 minutes. After cooling, dilute hydrochloric acid (1→2) is added to bring the total volume to 100 mL. And then 100 mL of dilute hydrochloric acid (1→2) is added 25 mL of resulting solution. This solution is again boiled for 5 minutes. While boiling and stirring, stannous chloride solution is drop-wise added until iron is reduced and yellow color disappears. 2 more drops of stannous chloride solution are added to the solution, where approximately 50 mL of water is added. It is then cooled to room temperature. 15 mL of saturated solution of mercury chloride is added while stirring vigorously. After setting aside for 5 minutes, add 15 mL of sulfuric acid · phosphoric acid mixture, which is prepared by slowly adding 75 mL of sulfuric acid to 300 mL of water and cooled. 75 mL of phosphoric acid is added, where water is added to bring the total volume to 500 mL. After adding 0.5 mL of barium diphenylaminsulfonate solution, it is titrated with 0.1 N potassium bichromate solution until it turns reddish violet.

1 mL of 0.1 N potassium bichromate solution = 5.585 mg of Fe

Ferrous Fumarate

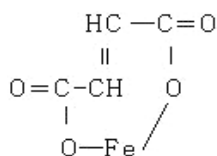

Chemical Formula: $\text{C}_4\text{H}_2\text{FeO}_4$

Molecular Weight: 169.90

Synonyms: Iron(II) fumarate

CAS No.: 141-01-5

Content Specifications of Ferrous Fumarate

Content Ferrous Fumarate should contain within a range of 97.0~101.0% of ferrous fumarate ($\text{C}_4\text{H}_2\text{FeO}_4$).

Description Ferrous Fumarate is scentless, and a orange red ~ reddish brown powder.

Identification (1) To 1.5 g of Ferrous Fumarate, add 25 mL of hydrochloric acid(1→2) and water to make 50 mL, and heat to dissolve the solid. After cooling, the solution is filtered through a glass filter. The precipitates are washed with diluted hydrochloric acid (3→100) and dried at 105°C. The filtrate is used in Identification (2). 40 mg of the dried precipitate is dissolved in 3 mL of water and 7 mL of 1 N sodium hydroxide solution. The solution is stirred until the solid is completely dissolved. Diluted hydrochloric acid is added to the solution until it turns acidic as determined with litmus paper. 1 g of p-nitrobenzyl bromide and 10 mL of alcohol are added to the solution, which is then refluxed for 2 hours. After cooling, it is filtered and the precipitates are washed with twice with small amount of alcohol and water mixture (2:1) and again twice with small amount of water. It is recrystallized in hot alcohol and dried at 105°C. The melting point should be approximately 152°C. (2) Test solution above (1) responds to the test for Ferric Salt in Identification.

Purity (1) Arsenic : It should be no more than 4.0 ppm tested by Arsenic Limit Test.

(2) Ferrous : 2 g of Ferrous Fumarate is transferred into a 250 mL Erlenmeyer flask with a stopper and 25 mL of water and 4 mL of hydrochloric acid are added to the flask, which is heated on a hot plate until the solid material dissolves completely. A stopper is placed and the flask is set-aside to be cooled to room temperature. 3 g of potassium iodide is added and the stopper is placed. The flask is set-aside for 5 minutes in a dark place. After adding 75 mL of water to the solution, which is then titrated with 0.1 N sodium thiosulfate solution using starch solution as an indicator. The consumption of sodium thiosulfate solution should not be more than 7.16 mL.

(3) Lead : 1.0 g of Ferrous Fumarate is weighed and transferred into 50 mL flask. Add 10 mL of 9 N hydrochloric acid, 10 mL of water, 20 mL of ascorbic acid-sodium iodide solution and 5 mL of trioctyl phosphine oxide solution and shake it to mix for 30 seconds. Keep it to separate the layer and again add water so that organic layer reaches to neck part of flask. After shaking to mix it, keep it to separate the layer. This organic solvent layer is used as test solution. Separately, take 10 mL of lead standard

solution and make it precisely to 100 mL. Take 2 mL of this solution and transfer into 50 mL flask. And operate under condition as test solution method, this solution is used as reference solution. When it is tested by Atomic Absorption Spectrophotometry or Inductively Coupled Plasma Emission Spectroscopy, absorbance(luminous intensity) of test solution should not be more than absorbance(luminous intensity) of reference solution.(not more than 2.0 ppm.)

Ascorbic acid-sodium iodide solution : 10 g of ascorbic acid and 19.3 g sodium iodide are dissolved in water to make to 100 mL.

Trioctyl phosphine oxide solution : 5 g of trioctyl phosphine oxide is dissolved in methyl isobutyl ketone to make to 100 mL.

(4) Mercury : When Ferrous Fumarate is tested according to Mercury Test, its content should not be more than 3.0 ppm.

(5) Sulfate: Transfer 1 g of Ferrous Fumarate into a 250 mL beaker and add water to make 100 mL, and heat in a water bath. Hydrochloric acid (approximately 2 mL) is added until the solid is completely dissolved. Filter the solution ~~filter~~ if necessary and add water to make 100 mL. After the solution is heated to boil, 10 mL of barium chloride solution is added, which is then heated for 2 hours in a water bath and set-aside over night. The precipitates are filtered and washed with hot water. The filter paper along with the precipitates is transferred into a crucible with a known weight and reduced to ash at 600°C. The crucible is then weighed. The amount of sulfate salts (as SO₄) should not be more than 0.2%. 1 mg of the residue corresponds to 0.412 mg of SO₄.

Loss on Drying When Ferrous Fumarate is dried for 16 hours at 105°C, the loss should not be more than 1%.

Assay Approximately 500 mg of Ferrous Fumarate is accurately weighed into a 500 mL Erlenmeyer flask and 25 mL of diluted hydrochloric acid (2→5) is added, which is heated to boil. A solution of 5.6 g stannous chloride in 50 mL of diluted hydrochloride solution (3→10) is added. When yellow color appears, 2 mL more is added. After cooling to room temperature, 8 mL of mercury chloride solution is added and the solution is set-aside for 5 minutes. 200 mL of water and 25 mL of diluted sulfuric acid (1→2), 4 mL phosphoric acid are added (Test Solution). After adding o-phenanthroline solution, the Test Solution is titrated with 0.1 N cerium II sulfate.

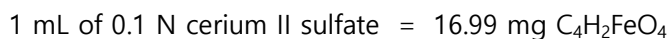

Ferrous Gluconate

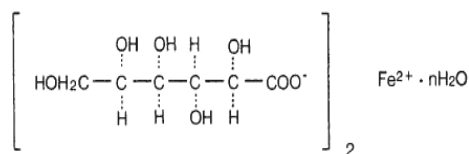

Chemical Formula: $\text{C}_{12}\text{H}_{22}\text{FeO}_{14} \cdot 2\text{H}_2\text{O}$

Molecular Weight: 482.18

INS No.: 579

Synonyms: Iron(II) gluconate

CAS No.: 299-29-6

Compositional Specifications of Ferrous Gluconate

Content Ferrous Gluconate, when calculated on the dried basis, should contain not less than 95.0% of anhydrous ferrous gluconate ($\text{C}_{12}\text{H}_{22}\text{FeO}_{14}$).

Description Ferrous Gluconate occurs as yellow-gray to green-yellow powder or granules, having a slight, characteristic odor.

Identification (1) To 5 mL of warm Ferrous Gluconate solution (1→10), add 0.7 mL of glacial acetic acid and 1 mL of freshly distilled phenylhydrazine. It is heated in a water bath for 30 minutes and cooled. When the inner wall is rubbed with a glass rod, crystals are precipitated. These crystals are collected and dissolved in 10 mL of hot water, where activated carbon is added. After mixing by shaking, it is filtered. After cooling, the inner wall is rubbed with a glass rod to precipitate crystals. The melting point of the dried crystals should be within a range of 192~202°C.

(2) Ferrous Gluconate solution (1→20) responds to the test for Ferrous Salt in Identification.

Purity (1) Arsenic : It should be no more than 4.0 ppm tested by Arsenic Limit Test.

(2) Ferric : 5 g of Ferrous Gluconate is transferred into a 250-mL Erlen Meyer flask with a stopper, where 100 mL of water and 10 mL of hydrochloric acid are added. 3 g of potassium iodide is added to the solution and the stopper is placed on the flask, which is then set aside for 5 minutes in a dark place. It is then titrated with 0.1N sodium thiosulfate solution using starch solution as an indicator. The consumption of the solution should not be more than 18 mL (not more than 2.0% as Fe^{3+}).

(3) Lead : When 5.0 g of Ferrous Gluconate is tested by Atomic Absorption Spectrophotometry or Inductively Coupled Plasma Emission Spectroscopy, its content should not be more than 2.0 ppm.

(4) Cadmium : When 5.0 g of Ferrous Gluconate is tested by Atomic Absorption Spectrophotometry or Inductively Coupled Plasma Emission Spectroscopy, its content should not be more than 1.0 ppm.

(5) Mercury : When Ferrous Gluconate is tested by Mercury Limit Test, its content should not be more than 1.0 ppm.

(6) Oxalate : Weigh 1 g of Ferrous Gluconate, dissolve in 10 mL of water and 2 mL of hydrochloric acid, transfer into a separating funnel, and perform extraction twice with 50 mL and 20 mL of ether. Combine the extracts. add 10 mL of water, evaporate the ether on a water bath, and add 1 drop of 36% acetic

acid and 1 mL of calcium acetate solution (1→20). No turbidity appears within 5 minutes.

(7) Reducing Sugar : Weigh 0.5 g of Ferrous Gluconate, add 10 mL of water, dissolve by warming, add 1 mL of ammonia solution, pass hydrogen sulfide through the solution, allow to stand for 30 minutes, and filter. Wash the residue on the filter paper twice with 5 mL of water each time, combine the filtrate and the washings, neutralize with hydrochloric acid, and add 2 mL of diluted hydrochloric acid. Concentrate the solution to about 10 mL. cool, add 5 mL of anhydrous sodium carbonate solution and 20 mL of water, filter, and add water to the filtrate to make 100 mL. To 5 mL of this solution, add 2 mL of Fehling solution, and boil for 1 minute. A yellow to red precipitate should not be formed immediately.

Loss on Drying When Ferrous Gluconate is dried for 4 hours at 105°C, the weight loss should be within a range of 6.5 ~ 10%.

Assay Accurately weigh about 1.5 g of Ferrous Gluconate, previously dried. dissolve in 75 mL of water and 15 mL of diluted sulfuric acid. and add 250 mg of zinc dust. Allow to stand for 20 minutes, filter through a Gooch crucible with thin layer previously prepared of zinc dust, wash the residue with 10 mL of diluted sulfuric acid and then with 10 mL of water, combine the filtrate and the washings, add 2 drops of o-phenanthroline solution, and titrate immediately with 0.1 N ceric sulfate. Separately, perform a blank test in the same manner.

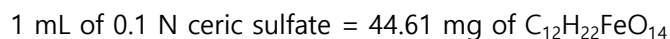

Ferrous Lactate

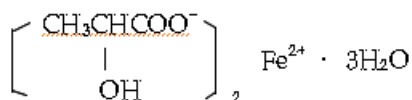

Chemical Formula: C₆H₁₀O₆Fe·3H₂O

Molecular Weight: 288.04

INS No.: 585

Synonyms: Iron(II) lactate; Iron(II) 2-hydroxypropanoate

CAS No.: 5905-52-2

Compositional Specifications of Ferrous Lactate

Content Ferrous Lactate should contain within a range of 15.5~20.0% of iron (Fe = 55.85).

Description Ferrous Lactate is greenish white ~ yellow crystalline powder or lump with characteristic scent and slightly sweet taste of iron

Identification (1) 0.5 g of Ferrous Lactate is heat-treated for 1 hour at 450~550°C. The resulting residue is dissolved in 3 mL of diluted hydrochloric acid (1→2). This solution responds to test of ferric salt in Identification.

(2) Ferrous Lactate responds to test of Lactate Salt in Identification.

Purity (1) Clarity and Color of Solution : When of 1 g of Ferrous Lactate is dissolved in 20 mL of water by heating in a water bath, the solution almost clear.

(2) Chloride : When 0.1 g of Ferrous Lactate is tested by Chloride Limit Test, Its content should not be more than the amount that corresponds to 0.2 mL of 0.01 N hydrochloric acid.

(3) Sulfate : 0.2 g of Ferrous Lactate is dissolved in 5 mL of water. The total volume is brought up to 10 mL with water. 2 mL of this solution is tested by Sulfate Limit Test salt. The amount of sulfate salt should correspond to 0.4 mL of 0.01 N sulfuric acid

(4) Arsenic : It should be no more than 4.0 ppm tested by Arsenic Limit Test.

(5) Lead : When 5.0 g of Ferrous Lactate is tested by Atomic Absorption Spectrophotometry or Inductively Coupled Plasma Emission Spectroscopy, its content should not be more than 1.0 ppm.

(6) Cadmium : When 5.0 g of Ferrous Lactate is tested by Atomic Absorption Spectrophotometry or Inductively Coupled Plasma Emission Spectroscopy, its content should not be more than 1.0 ppm.

(7) Mercury : When Ferrous Lactate is tested by Mercury Limit Test, its content should not be more than 1.0 ppm.

(8) Ferric Iron: 5 g of Ferrous Lactate, accurately weighed, transfer into a 250 mL glaze stoppered flask, dissolve in 100 mL of water and 10mL of hydrochloric acid. Add 3 g of potassium iodide, shake well, and allow to stand in the dark for 5 min. Titrate liberated iodine with 0.1N sodium thiosulfate, using

starch TS as the indicator, then the content should not be more than 0.6%.

1 mL of 0.1 N Sodium thiosulfate solution = 5.585 mg Fe(III)

(9) Readily Carbonizable Substances and Butyrate : 0.5 g powder of Ferrous Lactate is mixed with 1 mL of sulfuric acid, it should not be colored immediately and should not generate the odor of fatty acid.

Loss on Drying When Ferrous Lactate is dried using vacuum (approx. 700 mmHg) at 100°C, the weight loss should not be more than 18%.

Assay Approximately 1 g of Ferrous Lactate is precisely weighed and carbonized by slowly heating. 1 mL of nitric acid is added and evaporated to dryness, where care must be taken to prevent splashing. After further heat treatment, 10 mL of diluted hydrochloric acid (1→2) to the residue and the mixture is boiled until insoluble substances almost disappear. To this solution, 20 mL of water is added and then filtered. Insoluble residue is rinsed with water and the rinse water is added to the filtrate. The total volume of the filtrate is then brought up to 100 mL by adding water. 25 mL of the resulting solution is transferred into a flask with a stopper. After adding 2 g potassium iodide to the flask, The flask is sealed and set-aside for 15 minutes at a dark place. 100 mL of water is added and free iodine is titrated with 0.1 N sodium thiosulfate (indicator: starch solution). A blank test is done following the same procedure.

1 mL of 0.1 N sodium thiosulfate = 5.585 mg Fe

Ferrous Sulfate

Chemical Formula: FeSO_4

Molecular Weight: 151.91

CAS No.:

7782-63-0(crystal)

7720-78-7(dry)

Definition Ferrous Sulfate occurs as crystals (heptahydrate) called Ferrous Sulfate (crystal) and a dried substance (hydrated to sesquihydrate) called Ferrous Sulfate (dried).

Compositional Specifications of Ferrous Sulfate

Content Ferrous Sulfate (crystal) should contain within a range of 99.5 ~ 104.5% of ferrous sulfate heptahydrate ($\text{FeSO}_4 \cdot 7\text{H}_2\text{O} = 278.02$) and Ferrous Sulfate (dried) should contain within a range of 86.0 ~ 89.0% of ferrous sulfate ($\text{FeSO}_4 = 151.91$).

Description Ferrous Sulfate (crystal) occurs as whitish green crystals or crystalline powder. Ferrous Sulfate (dried) occurs as a gray ~ white powder.

Identification Ferrous Sulfate solution (1→100) responds to the tests for Ferrous Salt and Sulfate in Identification.

Purity (1) pH : pH of a solution of 1 g of Ferrous Sulfate (crystal) in 10 mL of water should be not less than 3.7.

(2) Arsenic : It should be no more than 4.0 ppm tested by Arsenic Limit Test.

(3) Lead : Accurately weigh 1.0 g of Ferrous Sulfate and transfer into a 50 mL flask, where 10 mL of 9N hydrochloric acid, 10 mL of water, 20 mL of ascorbic acid -sodium iodide solution, and 5 mL of trioctylphosphineoxid solution are added. Shake and mix it for 30 seconds, allow it to stand, and separate the layer. Again add water to set organic layer to the neck of the flask. Shake, mix, and set aside to separate the layer. The organic solvent layer is used as test solution. Separately, accurately measure 10 mL of lead standard solution to 100 mL, Accurately measure 2 mL of this solution into a 50 mL flask, and proceed in the same manner as test solution. When the test solution and reference solution are tested by Atomic Absorption Spectrophotometry or Inductively Coupled Plasma Emission Spectroscopy, its content should not be more than 2.0 ppm.

Ascorbic acid -sodium iodide solution: 10 g of ascorbic acid and 19.3g of sodium iodide solution are dissolved in water to make 100 mL.

Trioctylphosphineoxid solution : 5g of trioctylphosphineoxid is dissolved in methyl isobutyl ketone to make 100 mL.

(4) Mercury : When Ferrous Sulfate is tested by Mercury Limit Test, its content should not be more than 1.0 ppm.

Assay Accurately weigh about 0.5 g of Ferrous Sulfate, dissolve in a mixture of 25 mL of diluted sulfuric

acid (1→25) and 25 mL of freshly boiled and cooled water, and titrate with 0.1 N potassium permanganate.

- Ferrous Sulfate(crystal): 1 mL of 0.1N potassium permanganate = 27.802 mg of $\text{FeSO}_4 \cdot 7\text{H}_2\text{O}$
- Ferrous Sulfate(dried): 1 mL of 0.1N potassium permanganate = 15.191 mg of FeSO_4

Ferulic Acid

Chemical Formula: $C_{10}H_{10}O_4$

Molecular Weight: 194.18

CAS No.: 1135-24-6

Definition Ferulic acid is obtained by the following procedure. Rice bran oil from rice (*Oryza sativa* LINNE) of gramineae is fractioned with hydrated ethyl alcohol and hexane at room temperature. γ -Oryzanol, which is obtained from the fraction of ethyl alcohol, is hydrolyzed with hot sulfuric acid and purified. Its major component is ferulic acid.

Compositional Specifications of Ferulic Acid

Content If Ferulic acid is converted to a dehydrated form, it should contain not less than 98.0% ferulic acid ($C_{10}H_{10}O_4 = 194.18$).

Description Ferulic acid is white ~ pale yellowish brown crystalline powder with slight characteristic or no scent.

Identification (1) A solution of Ferulic acid in ethyl alcohol (1→100,000) has maximum absorption bands at 234~238 nm and 320~324 nm.

(2) When 0.01 g of Ferulic acid dissolve in 10 mL of 10% alcoholic solution of potassium hydroxide by heating, it becomes yellow in color.

(3) 0.01 g of Ferulic acid dissolve in 2 mL of acetone. When 0.1 mL of a solution of ferric chloride in ethyl alcohol (1→50) is added to this solution, it becomes reddish brown in color.

Purity (1) Arsenic : It should be no more than 4.0 ppm tested by Arsenic Limit Test.

(2) Lead : When 5.0 g of Ferulic acid is tested by Atomic Absorption Spectrophotometry or Inductively Coupled Plasma Emission Spectroscopy, its content should not be more than 2.0 ppm.

Loss on Drying When 1 g of Ferulic acid is dried for 3 hours at 105°C, the weight loss weight should not be more than 0.5%.

Residue on Ignition When Residue on Ignition analysis is done with accurately weighted 5 g of Ferulic acid, the amount of Residue on Ignition should not be more than 0.1%.

Assay Approximately 0.5 g of Ferulic acid is precisely weighted and dissolved in 50 mL of 50 v/v% ethyl alcohol solution by heating in a water bath. Cool the solution, it is titrated with 0.1 N sodium hydroxide solution. Separately, a blank test is carried out by the same method.

0.1 N sodium hydroxide solution 1 mL = 19.418 mg $C_{10}H_{10}O_4$

Folic Acid

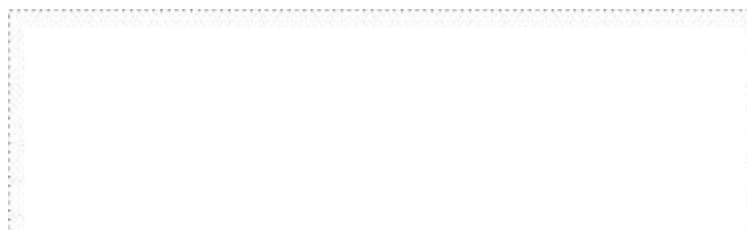

Chemical Formula: $C_{19}H_{19}O_6N_7$

Molecular Weight: 441.40

Synonyms: Pteroylglutamic acid; N-[4-[[[2-Amino-1,4-dihydro-4-oxo-6-pteridiny] methyl]amino]benzoyl]-L-glutamic acid

CAS No.: 59-30-3

Compositional Specifications of Folic Acid

Content Folic Acid should contain within a range of 98.0% ~ 102.0% of folic acid ($C_{19}H_{19}O_6N_7$).

Description Folic Acid occurs as a yellow to orange-yellow crystalline powder. It is odorless.

Identification Dissolve 1.5 mg of Folic Acid in sodium hydroxide solution (1→250) to make 100 mL. The solution exhibits absorption maxima at wave-lengths of 255 ~ 257 nm, 281 ~ 285 nm, and 361 ~ 369 nm.

Purity (1) Free Amine : Accurately weigh about 0.05 g of p-Aminobenzoylglutamic Acid Reference Standard, previously dried for 4 hours under reduced pressure in a desiccator(silica-gel), dissolve in alcohol(2→5) to make 100 mL. Take 5 mL of this solution, add water to make 1,000 mL. Take 4 mL of the solution and 5mL water and designate the solutions obtained through the ways to prepare test solution from B solution of each assay as S' solution and D solution. As setting D solution for the control solution, measure the absorption ratio of S' solution at 550 nm wavelength, obtaining the number as As' . Calculate the amount of free amine by the following formula from As' and Ac obtained in the Assay. It should is not be more than 1%.

Amount of free amine (%) =

$$\frac{Ac}{As'} \times \frac{\text{Weight of p-aminobenzoylglutamic acid reference standard(g)}}{\text{weight of the sample(g)}} \times \frac{100 - \text{Water content of the sample(\%)}}{100}$$

(2) Lead : When 5.0 g of Folic Acid is tested by Atomic Absorption Spectrophotometry or Inductively Coupled Plasma Emission Spectroscopy, its content should not be more than 2.0 ppm.

Water Content Folic Acid is tested by the back titration method in water content determination (Karl-

Fischer Method). The water content should not be more than 8.5%.

Residue on Ignition Residue on ignition of Folic Acid should not be more than 0.5%.

Assay 0.1 g of Folic Acid is precisely weighed and dissolved in 0.1 N sodium hydroxide solution to make 200 mL by well shaking. Take 25 mL of this solution add 20 mL of dilute hydrochloric acid and water to make 100 mL, Solution A. Take 60 mL of Solution A add 0.5 g of zinc powder, which is set-aside for 20 minutes while shaking occasionally. It is then filtered through a dry filter. Approximately 10 mL of the first filtrate is discarded. 10 mL of the remaining filtrate is diluted to 100 mL with water, Solution B. Take 5 mL of Solution B, add 1 mL of dilute hydrochloric acid and 1 mL of sodium nitrite solution (1→1,000) and mix well and set-aside for 2 minutes. 1 mL of ammonium sulfamate (1→200) is mixed well and set-aside for 2 minutes. To this solution, 1 mL of N-(1-naphthyl)-N-diethyl-ethylenediamine oxalate solution (1→1,000) is added, mixed, and set-aside for 10 minutes. This solution is diluted to 20 mL with water, Test Solution. Solution C is prepared using Solution A by following the same procedure to prepare Test Solution using Solution B. Standard Solution is prepared with approximately 0.1 g (precisely weighed) of folic acid standard by following the same procedure as sample. Separately, 5 mL of water is treated by the same procedure as the sample, Reference Solution. Absorption at 550 nm is measured for Test Solution, Solution C, and Standard Solution using Reference Solution as a reference, A, Ac, and As. The content of folic acid is calculated from the following equation. However, water contents in folic acid standard and sample are measured by the specified method.

$$\text{Content(\%)} = \frac{\text{Weight of Folic acid standard (g)}}{\text{A} - 0.1\text{Ac}} \times \frac{100 - \text{Water content of Folic acid standard(\%)}}{100} \times \frac{100}{\text{Weight of sample(g)}} \times \frac{100}{100 - \text{Water content of sample(\%)}}$$

Food Blue No.1



Chemical Formula: $C_{37}H_{31}O_9N_2S_3Na_2$

Molecular Weight: 792.88

INS No.: 133

Synonyms: Brilliant blue FCF; CI food blue 2

CAS No.: 3844-45-9

Definition Food Blue No. 1 consists mainly of disodium 2-[bis[4-[N-ethyl-N-(3-sulfonatophenylmethyl)amino]phenyl]methyl]benzenesulfonate

Compositional Specifications of Food Blue No.1

Content Food Blue No.1 should contain not less than 85.0% of disodium 3-[N-ethyl-N-4-[[4-[N-ethyl-N-(3-sulfonatebenzyl)amino]phenyl](2-sulfonatephenyl)methylene]-2,5-cyclohexadienylyden]ammoniomethyl]benzene sulfonate ($C_{37}H_{31}O_9N_2S_3Na_2$).

Description Food Blue No.1 occurs as blue ~ purple powder or granules. It is odorless. and has a metallic luster.

Identification (1) When 50 mg of Food Blue No.1 dissolved in 100 mL of water, the solution becomes blue color.

(2) When 0.1 g of Food Blue No.1 dissolved in 200 mL of 0.02 N ammonium acetate solution. To 1 mL of this solution, add 0.02 N ammonium acetate solution to make 100 mL. The solution exhibits absorption maximum at a wavelength of 630 ± 2 nm.

(3) To 5 mL of Food Blue No. 1 solution (1→1,000), add 1 mL of hydrochloric acid. The color of the solution becomes dark yellow ~ green color.

(4) When 1 mL of sodium hydroxide solution (1→10) is added to 5 mL of Food Blue No.1 solution (1→1,000), precipitate is not formed and color does not change.

(5) When 1 g of Food Blue No.1 dissolved in 10 mL of sulfuric acid, the solution becomes a dark orange color. When 5 mL of water is added to 2 ~ 3 drops of this solution, it becomes green color.

Purity (1) Water-insoluble substances : When Food Blue No.1 is proceeded as directed under Water-insoluble substance in Coloring matter Test, the content should not be more than 0.2%

(2) Chloride and sulfate : When Food Blue No.1 is proceeded as directed under Chloride and sulfate in Coloring matter Test, the total content should not be more than 4%.

(3) Arsenic : It should be no more than 4.0 ppm tested by Arsenic Limit Test.

(4) Chrome : When Food Blue No.1 is tested by Heavy Metals (2) in Coloring Matter Tests, its content

should not be more than 50 ppm.

(5) Mangan : When Food Blue No.1 is tested by Heavy Metals (4) in Coloring Matter Tests, its content should not be more than 50 ppm.

(6) Lead : When 5.0 g of Food Blue No.1 is tested by Atomic Absorption Spectrophotometry or Inductively Coupled Plasma Emission Spectroscopy, its content should not be more than 2.0 ppm.

(7) Cadmium : When 5.0 g of Food Blue No.1 is tested by Atomic Absorption Spectrophotometry or Inductively Coupled Plasma Emission Spectroscopy, its content should not be more than 1.0 ppm.

(8) Mercury : When Food Blue No.1 is tested by Mercury Limit Test, its content should not be more than 1.0 ppm.

(9) Unsulfonated Primary Aromatic Amines : When G. Unsulfonated Primary Aromatic Amines in Coloring Matter Tests is done, the content should not be more than 0.01% as Aniline.

(10) Other Coloring Matters : Proceed as directed under Purity (9) in 「Food Green No. 3」.

Loss on Drying When Food Blue No.1 is dried for 6 hours at 135°C, the weight loss should not be more than 10%.

Assay Accurately weigh about 4.8 g of Food Blue No. 1, and dissolve it in water to make exactly 250 mL. Measure exactly 50 mL of this solution, and use it as the test solution. Proceed as directed under Titanium Trichloride Method (B) of Assay in Coloring matter Tests.

1 mL of 0.1 N titanium trichloride = 39.64 mg of $C_{37}H_{34}O_9N_2S_3Na_2$

Food Blue No.1 Aluminium Lake

Synonyms: Brilliant blue FCF aluminium lake

Definition Food Blue No. 1 Aluminum Lake is prepared by reacting an aluminum salt solution with alkali, making the reaction product adsorb Food Blue No. 1, filtering, drying, and crushing.

Compositional Specifications of Food Blue No. 1 Aluminum Lake

Content Food Blue No.1 Aluminum Lake should contain not less than 10.0% of 3-[N-ethyl-N- [4-[[4-[N-ethyl-N-(3-sulfobenzyl)amino]phenyl](2-sulfophenyl)methylene]-2,5-cyclohexadienylidene]ammoniomethyl]benzene sulfonic acid ($C_{37}H_{36}O_9N_2S_3=748.90$).

Description Food Blue No.1 Aluminum Lake occurs as a fine blue powder. It is odorless.

Identification (1) To 0.1 g of Food Blue No. 1 Aluminum Lake, add 5 mL of diluted sulfuric acid, shake well and add 0.02 N ammonium acetate solution to make 200 mL. If the solution is not clear, it is centrifuged. Measure 1 ~ 10 mL of this solution so that the absorbance to be measured will be within a range of 0.2 ~ 0.7, and add ammonium acetate solution to make 100 mL. The solution exhibits absorption maximum at a wavelength of 630 ± 2 nm.

(2) To 0.1 g of Food Blue No.1 Aluminum Lake, add 5 mL of diluted hydrochloric acid and heat in a water bath for about 5 minutes while shaking occasionally. It dissolves almost clearly, and becomes a green to dark green color. Cool. and neutralize with ammonia solution. A blue color becomes and a gelatinous precipitate of the same color is formed.

(3) To 0.1 g of Food Blue No.1 Aluminum Lake, add 5 mL of sodium hydroxide solution (1→10). and heat in a water bath for about 5 minutes while shaking occasionally. It dissolves almost clearly, and becomes a red purple color. After cooling, it is neutralized with diluted hydrochloric acid. A blue to red purple color occurs, and a gelatinous precipitate of the same color is formed.

(4) To 0.1 g of Food Blue No.1 Aluminum Lake, add 5 mL of sulfuric acid, and heat in a water bath for about 5 minutes while shaking occasionally. A dark yellow to dark gray-brown color occurs. After cooling, add 2 ~ 3 drops of the supernatant to 5 mL of water. A blue to blue-green color occurs.

(5) To 0.1% of Food Blue No.1 Aluminum Lake, add 10 mL of diluted hydrochloric acid, heat in a water bath until most of it dissolves, add 0.5 g of active carbon, shake well, and filter. The colorless filtrate is neutralized with sodium hydroxide solution (1→10). The solution responds to the test for Aluminum Salt in Identification.

Purity (1) Hydrochloric Acid and Ammonia Insolubles Substances : When Food Blue No.1 Aluminum Lake is proceeded as directed under Hydrochloric Acid and Ammonia Insolubles Substances in Coloring Matter Aluminum Lake Test, the content should not be more than 0.5%.

(2) Arsenic : It should be no more than 4.0 ppm tested by Arsenic Limit Test.

(3) Lead : When 5.0 g of Food Blue No.1 Aluminum Lake is tested by Atomic Absorption Spectrophotometry or Inductively Coupled Plasma Emission Spectroscopy, its content should not be more than 5.0 ppm.

(4) Barium : When Food Blue No.1 Aluminum Lake is proceeded as directed under Barium in Coloring matter Aluminum Lake Test, it should be appropriate (not more than 500 ppm as Ba).

(5) Other Coloring matters : Proceed as directed under Purity (5) in 「Food Green No.3 Aluminum Lake」.

Loss on Drying When Food Blue No.1 is dried for 6 hours at 135°C, the weight loss should not be more than 30%.

Assay Accurately weigh Food Blue No.1 Aluminum Lake so that the volume of consumed 0.1 N titanium trichloride will be about 20 mL, and proceed as directed under Assay (2) in Coloring Matter Aluminum Lake Test.

1 mL of 0.1 N titanium trichloride solution = 37.44 mg $C_{37}H_{36}O_9N_2S_3$

Food Blue No.2



Chemical Formula: $C_{16}H_8O_8N_2S_2Na_2$

Molecular Weight: 466.37

INS No.: 132

Synonyms: Indigocarmine; Indigotine; CI food
blue 1

CAS No.: 860-22-0

Definition Food Blue No.2 consists principally of the disodium salt of 3,3'-dioxo-2,2'-biindolylidene-5,5'-disulfonic acid.

Compositional Specifications of Food Blue No. 2

Content Food Blue No.2 should not be less than 85.0 % of the disodium salt of 3,3'-dioxo-2,2'-biindolylidene-5,5'-disulfonic acid ($C_{16}H_8O_8N_2S_2Na_2$).

Description Food Blue No.2 occurs as dark purple-blue to dark purple-brown powder or granules. It is odorless.

Identification (1) When 50 mg of Food Blue No.2 is dissolved in 10 mL of water, the solution becomes purple-blue in color.

(2) 0.1 g of Food Blue No.2 is dissolved in 100 mL of 0.02 N ammonium acetate solution. To 1 mL of this solution, add 0.02 N ammonium acetate solution to make 100 mL. The solution exhibits absorption maximum at a wave-length of 612 ± 2 nm.

(3) To 5 mL of Food Blue No.2 solution (1→1,000), add 1 mL of sodium hydroxide solution (1→10). The color of the solution changes to yellow-green.

(4) When 0.1 g of Food Blue No.2 is dissolved in 10 mL of sulfuric acid, the solution becomes deep purple in color. Add 2 to 3 drops of this solution to 5 mL of water, the solution becomes purple-blue in color.

Purity (1) Water-insoluble substances : When Food Blue No.2 is proceeded as directed under Water-insoluble substance in Coloring matter Test, the content should not be more than 0.2%.

(2) Chloride and sulfate : When Food Blue No.2 is proceeded as directed under Chloride and sulfate in Coloring matter Test, the total content should not be more than 7%.

(3) Arsenic : It should be no more than 4.0 ppm tested by Arsenic Limit Test.

(4) Iron : When Food Blue No.2 is proceeded as directed under Heavy Metals (3) in Coloring matter Test, its content should not be more than 500 ppm.

(5) Lead : When 5.0 g of Food Blue No.2 is tested by Atomic Absorption Spectrophotometry or Inductively Coupled Plasma Emission Spectroscopy, its content should not be more than 2.0 ppm.

- (6) Cadmium : When 5.0 g of Food Blue No.2 is tested by Atomic Absorption Spectrophotometry or Inductively Coupled Plasma Emission Spectroscopy, its content should not be more than 1.0 ppm.
- (7) Mercury : When Food Blue No.2 is tested by Mercury Limit Test, its content should not be more than 1.0 ppm.
- (8) Unsulfonated Primary Aromatic Amines : When G. Unsulfonated Primary Aromatic Amines in Coloring Matter Tests is done, the content should not be more than 0.01% as Aniline.
- (9) Other Coloring Matters : Proceed as directed under Purity (9) in 「Food Green No. 3」. In this case, 0.1 g of sample is dissolved in water to make 100 mL solution.

Loss on Drying When Food Blue No.2 is dried for 6 hours at 135°C, the weight loss should not be more than 10%.

Assay Accurately weigh about 2.7 g of Food Blue No.2, and dissolve it in water to make exactly 500 mL. Measure exactly 100 mL of this solution, and use it as the test solution. Proceed as directed under Titanium Trichloride Method (B) of Assay in Coloring Matter Tests.

1 mL of 0.1 N titanium trichloride = 23.32 mg of $C_{16}H_8O_8N_2S_2Na_2$

Food Blue No.2 Aluminium Lake

Synonyms: Indigocarmine aluminium lake

Definition Food Blue No.2 Aluminum Lake is prepared by reacting an aluminum salt solution with alkali, making the reaction product adsorb Food Blue No.2, filtering, drying, and crushing.

Compositional Specifications of Food Blue No.2 Aluminum Lake

Content Food Blue No.2 Aluminum Lake should not be less than 10.0% of 3, 3'-dioxo-2,2'-biindolinylidene-5,5'-disulfonic acid ($C_{16}H_{10}N_2O_8S_2 = 422.40$).

Description Food Blue No.2 Aluminum Lake occurs as a fine purplish-blue powder. It is odorless.

Identification (1) To 0.1 g of Food Blue No.2 Aluminum Lake, add 5 mL of diluted sulfuric acid, where 0.02 N ammonium acetate solution is added to make the total volume to 100 mL. When this solution is not clear, it is centrifuged. 1 ~ 10 mL of this solution is diluted to 100 mL with 0.02 N ammonium acetate solution so that the absorbance to be measured will be within a range of 0.2 ~ 0.7. This solution exhibits absorption maximum at a wavelength of 612 ± 2 nm.

(2) To 0.1 g of Food Blue No.2 Aluminum Lake, add 5 mL of sodium hydroxide solution (1→10). While shaking occasionally, it is heated for 5 minutes in a water bath. The solution becomes almost clear and becomes yellowish brown color. After cooling, the solution is neutralized with diluted hydrochloric acid, it becomes blue purple ~ light green color and gelatinous precipitate of the same color is formed.

(3) To 0.1g of Food Blue No.2 Aluminum Lake, add 5 mL of sulfuric acid. While shaking occasionally, it is heated for 5 minutes in a water bath. The solution becomes deep blue ~ purple color. After cooling, 2 ~ 3 drops of the supernatant are added to 5 mL of water. This solution becomes blue ~ purple.

(4) To 0.1 g of Food Blue No.2 Aluminum Lake, add 10 mL of dilute hydrochloric acid, which is heated in a water bath. Most of the solid material is dissolved. 0.5 g of activated carbon is added and well mixed, which is then filtered. The colorless filtrate is neutralized with sodium hydroxide solution (1→10). It responds to the test for ϕ aluminum salt in Identification.

Purity (1) Hydrochloric Acid and Ammonia Insolubles Substances : When Food Blue No.2 Aluminum Lake is proceeded as directed under Hydrochloric Acid and Ammonia Insolubles Substances in Coloring Matter Aluminum Lake Test, the content should not be more than 0.5%.

(2) Arsenic : It should be no more than 4.0 ppm tested by Arsenic Limit Test.

(3) Iron : When Food Blue No.2 Aluminum Lake is proceeded as directed under Heavy Metals (3) in Coloring matter Test, the content should not be more than 250 ppm.

(4) Lead : When 5.0 g of Food Blue No.2 Aluminum Lake is tested by Atomic Absorption Spectrophotometry or Inductively Coupled Plasma Emission Spectroscopy, its content should not be more than 5.0 ppm.

(5) Barium : When Food Blue No.2 Aluminum Lake is proceeded as directed under Barium in Coloring matter Aluminum Lake Test, it should be appropriate (not more than 500 ppm as Ba).

(6) Other Coloring Matters : Proceed as directed under Purity (5) in 「Food Green No.3 Aluminum Lake」. In this case, an amount of sample is used so that it contains 0.1 g as Color acid. Take a sample of Food Blue No. 2 Aluminum Lake to contain 0.1 g as color acid and use acetic acid(1→3) instead of acetic acid(1→20)

Loss on Drying When Food Blue No.2 Aluminum Lake is dried for 6 hours at 135°C, the weight loss should not be more than 30%.

Assay Accurately weigh Food Blue No.2 Aluminum Lake so that the volume of consumed 0.1 N titanium trichloride will be about 20 mL, and proceed as directed under Assay (2) in Coloring Matter Aluminum Lake Test.

1 mL of 0.1 N titanium trichloride = 21.12 mg of $C_{16}H_{10}O_8N_2S_2$

Food Green No.3



Chemical Formula: $C_{37}H_{34}O_{10}N_2S_3Na_2$

Molecular Weight: 808.88

INS No.: 143

Synonyms: Fast green FCF; CI food green 3

CAS No.: 2353-45-9

Definition Food Green No.3 consists principally of disodium 2-[bis[4-[N-ethyl-N-(3-sulfonatophenylmethyl)amino]phenyl]methyl]-5-hydroxybenzenesulfonate

Compositional Specifications of Food Green No.3

Content Food Green No.3 should contain not less than 85.0% of disodium 3-[bis[4-N-ethyl-N-(4-[[4-[N-ethyl-N(3-sulfonatophenyl)phenyl](4-hydroxy-2-sulfonatophenyl) methylene]-2,5-cyclohexadienylidene]ammonio-methyl]benzenesulfonate ($C_{37}H_{34}O_{10}N_2S_3Na_2$).

Description Food Green No.3 occurs as dark green powder or granules. It is odorless and has a metallic luster.

Identification (1) Dissolve 50 mg of Food Green No.3 in 100 mL of water. This solution is bluish green in color.

(2) 0.1 g of Food Green No.3 is dissolved in 200 mL of 0.02 N ammonium acetate solution. When 1 mL of this solution is diluted to 100 mL with 0.02 N ammonium acetate solution, it shows a maximum absorption band at 628 ± 2 nm.

(3) When 1 mL of hydrochloric acid is added to 5 mL of an aqueous solution (1→1,000) of Food Green No.3, the color of the solution changes to brown.

(4) When 1 mL of sodium hydroxide solution (1→10) is added to 5 mL of an aqueous solution (1→1,000) of Food Green No.3, the color of the solution changes to bluish purple.

(5) When 0.1 g of Food Green No.3 is dissolved in 10 mL of sulfuric acid, it shows an orange color. When 2 ~ 3 drops of this solution are added to 5 mL of water, the color becomes green.

Purity (1) Water Insoluble Matter : When Food Green No.3 proceeds as directed under water insoluble matter in the Coloring Matter Test, the content should not be more than 0.2%.

(2) Chlorides and Sulfates : When Food Green No.3 proceed as directed under Chlorides and Sulfates in the Coloring Matter Test, the total content should not be more than 5%.

(3) Arsenic : It should be no more than 4.0 ppm tested by Arsenic Limit Test.

- (4) Chrome : When Food Green No.3 is tested by Heavy Metal Limit Test (2) in Coloring Matter Tests, its content should not be more than 50 ppm.
- (5) Mangan : When Food Green No.3 is tested by Heavy Metals (4) in Coloring Matter Tests, its content should not be more than 50 ppm.
- (6) Lead : When 5.0 g of Food Green No.3 is tested by Atomic Absorption Spectrophotometry or Inductively Coupled Plasma Emission Spectroscopy, its content should not be more than 2.0 ppm.
- (7) Mercury : When Food Green No.3 is tested by Mercury Limit Test, its content should not be more than 1.0 ppm.
- (8) Unsulfonated Primary Aromatic Amines : When G. Unsulfonated Primary Aromatic Amines in Coloring Matter Tests is done, the content should not be more than 0.01% as Aniline.
- (9) Other coloring matters : 0.1 g of Food Green No.3 is dissolved in water to make 200 mL. 0.002 mL of this solution is used as a Test Solution. A mixture of n-butyl alcohol, anhydrous alcohol, and 1% ammonia solution (6:2:3) is used as a developing solution. When the test solution is tested by Method 1 in Paper Chromatography, there should be only one spot. In this case, No.2 filter paper for chromatography is used and developing is stopped when the developing solvent front reaches approximately 15 cm. It is blow dried and observed under a natural light with a white background from the top. A reference solution is not used.

Loss on Drying Food Green No.3 is dried for 6 hours at 135°C and the weight loss should not be more than 10%.

Assay Accurately weigh about 4.7 g of Food Green No. 3, and dissolve in water to make exactly 250 mL. Measure exactly 50 mL of this solution, use it as the test solution, and proceed as directed under Titanium Trichloride Method (B) of Assay in Coloring Matter Tests.

$$1 \text{ mL of } 0.1 \text{ N titanium trichloride} = 40.44 \text{ mg of } \text{C}_{37}\text{H}_{34}\text{O}_{10}\text{N}_2\text{S}_3\text{Na}_2$$

Food Green No.3 Aluminium Lake

Synonyms: Fast green FCF aluminium lake

Definition Food Green No. 3 Aluminum Lake is prepared by reacting an aluminum salt solution with alkali, making the reaction product adsorb Food Green No. 3, filtering, drying, and crushing.

Compositional Specifications of Food Green No.3 Aluminum Lake

Content Food Green No.3 Aluminum Lake should contain not less than 10.0% of 3-[N-ethyl-N-[4-[[4[N-ethyl-N-(3-sulfobenzil)amino]phenyl]]-(4-hydroxy-2-sulfophenyl)methylene]-2,5-cyclohexanedianiliden] ammoniomethyl] benzenesulfonic acid ($C_{37}H_{36}O_{10}N_2S_3 = 764.90$).

Description Food Green No. 3 Aluminum Lake occurs as a fine, dark green-blue powder. It is odorless.

Identification (1) To 0.1 g of Food Green No. 3 Aluminum Lake, add 5 mL of dilute sulfuric acid, where 0.02 N ammonium acetate solution is added to bring the total volume to 200 mL. When this solution is not clear, it is centrifuged. 1 ~ 10 mL of this solution is diluted to 100 mL with 0.02 N ammonium acetate solution so that the measured absorbance falls in a range of 0.2 ~ 0.7. This solution has a maximum absorption band at 626 ± 2 nm.

(2) To 0.1 g of Food Green No.3 Aluminum Lake, add 5 mL of dilute hydrochloric acid. While shaking occasionally, it is heated for 5 minutes in a water bath. The solid dissolves completely and the solution becomes clear and dark green. After cooling, when the solution is neutralized with ammonia solution, it becomes bluish green and gel-like precipitates with same color are produced.

(3) To 0.1 g of Food Green No.3 Aluminum Lake, add 5 mL of sodium hydroxide solution (1→10). While shaking occasionally, it is heated for 5 minutes in a water bath. The solid dissolves completely and the solution becomes clear and reddish violet. After cooling, when the solution is neutralized with dilute hydrochloric acid, it becomes bluish green and gel-like precipitates with same color are produced.

(4) To 0.1 g of Food Green No. 3 Aluminum Lake, add 5 mL of sulfuric acid. While shaking occasionally, it is heated for 5 minutes in a water bath. The solution becomes dark orange in color. After cooling, 2 ~ 3 drops of the supernatant are added to 5 mL of water. This solution turns green.

(5) To 0.1 g of Food Green No.3 Aluminum Lake add 10 mL of dilute hydrochloric acid, which is heated in a water bath. Most of the solid material is dissolved. 0.5 g of activated carbon is added and well mixed, which is then filtered. The colorless filtrate is neutralized with sodium hydroxide solution (1→10). It responds to test of aluminum salt in Identification.

Purity (1) Hydrochloric Acid and Ammonia Insoluble Substances : When Food Green No.3 Aluminum Lake is tested for Hydrochloric acid and ammonia insoluble substances in Coloring Matter Aluminum Lake Test, its content should not be more than 0.5%.

(2) Arsenic : It should be no more than 4.0 ppm tested by Arsenic Limit Test.

- (3) Lead : When 5.0 g of Food Green No.3 Aluminum Lake is tested by Atomic Absorption Spectrophotometry or Inductively Coupled Plasma Emission Spectroscopy, its content should not be more than 5.0 ppm.
- (4) Barium : When Food Green No.3 Aluminum Lake is tested by the procedure in Barium Test for [Aluminum Lake], it should be appropriate (not more than 500 ppm as Ba).
- (5) Other Coloring Matters : 60 mL of dilute acetic acid (1→20) is added to an amount of Food Green No. 3 Aluminum Lake containing 50 mg as a coloring acid. It is heated to boil and cooled. To this solution, acetone is added to bring the total volume to 100 mL. 0.002 mL of the supernatant is used as Test Solution. Using a mixture of n-butyl alcohol, anhydrous alcohol, and 1% ammonia solution (6:2:3) as a developing solvent. When the Test Solution is tested by Method 1 in Paper Chromatography, there should be only one spot. In this case, No. 2 filter paper for chromatography is used and developing is stopped when the developing solvent front reaches approximately 15 cm. It is blow dried and observed under a natural light with a white background from the top. A reference solution is not used.

Loss on Drying Food Green No.3 Aluminum Lake is dried for 6 hours at 135°C and the weight loss should not be more than 30%.

Assay Accurately weigh Food Green No. 3 Aluminum Lake, so that the volume of consumed 0.1N titanium trichloride is approximately 20 mL, and proceed as directed under H. Assay (2) in the Coloring Aluminum Lake Matter Test.



Food Red No.102

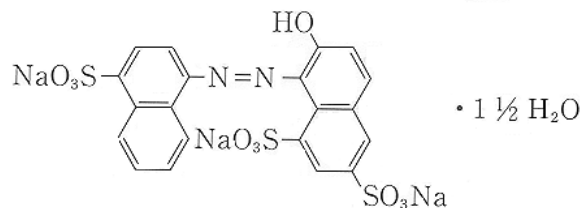

Chemical Formula: C₂₀H₁₁N₂Na₃O₁₀S₃ · 1½H₂O

Molecular Weight: 631.51

INS No.: 124

Synonyms: New cocchine; Ponceau 4R

CAS No.: 2611-82-7

Compositional Specifications of Food Red No.102

Content Food Red No.102 should contain not less than 85.0% of the trisodium salt of 7-hydroxy -8-(4-sulfonaphthylazo)-1,3-naphthalenedisulfonic acid, sesquihydrate (C₂₀H₁₁N₂Na₃O₁₀S₃ · 1½H₂O).

Description Food Red No.102 occurs as red to dark red powder or granules. It is odorless.

Identification (1) A solution of 0.1 g of Food Red No.102 in 100 mL of water is red in color.

(2) A solution of 0.1 g of Food Red No.102 in 10 mL of sulfuric acid is reddish violet. When 2 ~ 3 drops of this solution is added to 5 mL of water, a yellow ~ red color develops.

(3) 0.1 g of Food Red No.102 is dissolved in 100 mL solution of ammonium acetate (3→2,000). When 1 mL of this solution is diluted to 100 mL with ammonium acetate solution (3→2,000), it shows a maximum absorption band at 508 ± 2 nm.

Purity (1) Water-insoluble substances : When Food Red No.102 proceed as directed under Water Insoluble Substances in the Coloring Matter Test, the content should not be more than 0.2%.

(2) Chloride and Sulfate : When Food Red NO.102 proceed as directed under Chlorides and Sulfates in the Coloring Matter Test, the total content should not be more than 8.0%.

(3) Arsenic : It should be no more than 4.0 ppm tested by Arsenic Limit Test.

(4) Lead : When 5.0 g of Food Red No.102 is tested by Atomic Absorption Spectrophotometry or Inductively Coupled Plasma Emission Spectroscopy, its content should not be more than 2.0 ppm.

(5) Cadmium : When 5.0 g of Food Red No.102 is tested by Atomic Absorption Spectrophotometry or Inductively Coupled Plasma Emission Spectroscopy, its content should not be more than 1.0 ppm.

(6) Mercury : When Food Red No.102 is tested by Mercury Limit Test, its content should not be more than 1.0 ppm.

(7) Other coloring matters : Proceed as directed under Purity (9) in Food Green No.3.

(8) Unreacted Raw Material and Reaction Intermediate : To 100 mg of Food Red No.102 is dissolved in ammonium acetate solution (1.54→1000) to make 100 mL as the Test Solution. Separately, 10 mg each of 4-aminobenzenesulfonic acid, 7-hydroxy-1,3-naphthalenedisulfonic acid disodium salt, 3-hydroxy-2,7-naphthalene-disulfonic acid disodium salt, 6-hydroxy-2-naphthalenedisulfonic acid monosodium salt, 6,6'-oxybis[2-naphthalenesulfonic acid disodium salt], and disodium salt of 4,4'-(Diaz amino)-dibenzensulfonic acid (each was dried for 24 hours in a vacuum desiccator) is dissolved in ammonium acetate solution (1.54→1000) to make 100 mL of Standard Solution, respectively. By following the procedure in F. Unreacted Raw Material and Reaction Intermediate in Coloring Matter Tests under the following operation conditions, the contents of 4-amino-1-naphthalenesulfonic acid monosodium salt, 7-hydroxy-1,3-naphthalenedisulfonic acid disodium salt, 3-hydroxy-2,7-naphthalenedisulfonic acid disodium salt, 6-hydroxy-2-naphthalenesulfonic acid monosodium salt, and 7-hydroxy-1,3,6-naphthalenetrisulfonic acid trisodium salt should not be more than 0.5%.

Operation Conditions

-Detector: Visible Absorption Detector (wave length 238 nm)

-Carrier Phase : A - Ammonium acetate solution (1.54→1000)

B - Acetonitrile

-After keeping Solution A for 5 minutes,

Solution A : Solution B(100:0) → Solution A: Solution B (70:30) 50 minutes

(9) Unulfonated Primary Aromatic Amines : When Food Red No.102 is tested by following the procedure in G. Unulfonated Primary Aromatic Amines in Coloring Matter Tests, the content should not be more than 0.01%.

Loss on Drying When Food Red No.102 is dried for 6 hours at 135°C, the weight loss should not be more than 10.0%.

Assay Accurately weigh about 1.7 g of Food Red No.102, and dissolve in water to make 250 mL. Measure exactly 50 mL of this solution, use it as the test solution, and proceed as directed under Titanium Trichloride Method (A) of Assay in Coloring Matter Tests.

1 mL of 0.1 N titanium trichloride = 15.788 mg of $C_{20}H_{11}N_2Na_3O_{10}S_3 \cdot 1\frac{1}{2}H_2O$

Food Red No.2



Chemical Formula: $C_{20}H_{11}O_{10}N_2S_3Na_3$

Molecular Weight: 604.50

INS No.: 123

Synonyms: Amaranth; CI Food Red 9

CAS No.: 915-67-3

Definition Food Red No. 2 is obtained by coupling diazotized 4-amino-1-naphthalenesulfonic acid with 3-hydroxy-2,7-naphthalenedisulfonic acid, salting out, and refining. It consists principally of the trisodium salt of 3-hydroxy-4-(4-sulfonaphthylazo)-2,7-naphthalenedisulfonic acid.

Compositional Specifications of Food Red No. 2

Content Food Red No. 2 should contain not less than 85.0% of trisodium-2-hydroxyazonaphthalene-3,4',6-sulfonate ($C_{20}H_{11}O_{10}N_2S_3Na_3 = 604.50$).

Description Food Red No.2 occurs as reddish brown to dark reddish brown powder or granule. It is odorless.

Identification (1) When 0.1 g of Food Red No.2 is dissolved in 100 mL of water, the solution becomes purplish red color.

(2) When 0.1 g of Food Red No.2 is dissolved in 100 mL of 0.02 N ammonium acetate solution. 1 mL of this solution is diluted to 100 mL with 0.02 N ammonium acetate solution. The resulting solution exhibits absorption maximum at a wavelength of 520 ± 2 nm.

(3) When 0.1 g of Food Red No. 2 is dissolved in 10 mL of sulfuric acid, the solution becomes red color. When 5 mL of water is added to 2 ~ 3 drops of this solution, it becomes purplish red color.

Purity (1) Water Insoluble Substances : When Food Red No.2 proceed as directed under Water Insoluble Substances in the Coloring Matter Test, the content should not be more than 0.2%.

(2) Chlorides and Sulfates : When Food Red No.2 proceed as directed under Chlorides and Sulfates in the Coloring Matter Test, the total content should not be more than 5%.

(3) Arsenic : It should be no more than 4.0 ppm tested by Arsenic Limit Test.

(4) Lead : When 5.0 g of Food Red No.2 is tested by Atomic Absorption Spectrophotometry or Inductively Coupled Plasma Emission Spectroscopy, its content should not be more than 2.0 ppm.

(5) Cadmium : When 5.0 g of Food Red No.2 is tested by Atomic Absorption Spectrophotometry or Inductively Coupled Plasma Emission Spectroscopy, its content should not be more than 1.0 ppm.

(6) Mercury : When Food Red No.2 is tested by Mercury Limit Test, its content should not be more than 1.0 ppm.

(7) Unsulfonated Primary Aromatic Amines : When G. Unsulfonated Primary Aromatic Amines in Coloring Matter Tests is done, the content should not be more than 0.01% as Aniline.

(8) Other Coloring Matters : Proceed as directed under Purity (9) in 「Food Green No.3」. In this case, 0.1 g of sample is dissolved in water to make 100 mL solution.

Loss on Drying When Food Red No.2 is dried for 6 hours at 135°C, the weight loss should not be more than 10%.

Assay Accurately weigh about 1.7 g of Food Red No.2, and dissolve in water to make 250 mL solution. Measured exactly 50 mL of the solution, and proceed as directed under Assay (A) Titanium Trichloride in the Coloring Matter Test.

1 mL of 0.1 N titanium trichloride solution = 15.11 mg $C_{20}H_{11}O_{10}N_2S_3Na_3$

Food Red No.2 Aluminium Lake

Synonyms: Amaranth aluminium lake

Definition Food Red No. 2 Aluminum Lake is prepared by reacting an aluminum salt solution with alkali, making the reaction product adsorb Food Red No. 2, filtering, drying, and crushing.

Compositional Specifications of Food Red No.2 Aluminum Lake

Content Food Red No.2 Aluminum Lake should contain not less than 10.0% of 2-hydroxyazonaphthalene-3,4',6-trisulfonic acid ($C_{20}H_{14}O_{10} N_2S_3 = 538.54$).

Description Food Red No.2 Aluminum Lake occurs as a fine, purplish red powder. It is odorless.

Identification (1) To 0.1 g of Food Red No.2 Aluminum Lake, add 5 mL of diluted sulfuric acid, where 0.02 N ammonium acetate solution is added to make the total volume to 100 mL. When this solution is not clear, it is centrifuged. 1 ~ 10 mL of this solution is diluted to 100 mL with 0.02 N ammonium acetate solution so that the absorbance to be measured will be within a range of 0.2 to 0.7. This solution has a maximum absorption band at 520 ± 2 nm.

(2) To 0.1 g of Food Red No.2 Aluminum Lake, add 5 mL of hydrochloric acid. While shaking occasionally, it is heated for 5 minutes in a water bath. The solution becomes violet color. After cooling, 2 ~ 3 drops of supernatant are added to 5 mL of water, then it becomes purplish red color.

(3) To 0.1 g of Food Red No.2 Aluminum Lake, add 10 mL of diluted hydrochloric acid, which is heated in a water bath. Most of the solid material is dissolved. 0.5 g of activated carbon is added and well mixed, which is then filtered. The colorless filtrate is neutralized with sodium hydroxide solution (1 → 10). It responds to the test for aluminum salt in Identification.

Purity (1) Hydrochloric Acid and Ammonia Insoluble Substances : When Food Red No.2 Aluminum Lake is proceeded as directed under Hydrochloric Acid and Ammonia Insoluble Substances in the Coloring Matter Aluminum Lake, the content should not be more than 0.5%.

(2) Arsenic : It should be no more than 4.0 ppm tested by Arsenic Limit Test.

(3) Lead : When 5.0 g of Food Red No.2 Aluminum Lake is tested by Atomic Absorption Spectrophotometry or Inductively Coupled Plasma Emission Spectroscopy, its content should not be more than 5.0 ppm.

(4) Barium : When Food Red No.2 Aluminum Lake is proceeded as directed under Barium Test in Coloring Matter Aluminum Lake, it should be appropriate (not more than 500 ppm as Ba).

(5) Other coloring matters : Proceed as directed under Purity (6) in 「Food Green No. 3 Aluminum Lake」. In this case, sample is taken so that it contains 0.1 g of color acid.

Loss on Drying When Food Red No.2 Aluminum Lake is dried for 6 hours at 135°C, the weight loss

should not be more than 30%.

Assay Accurately weigh of Food Red No.2 Aluminum Lake so that the volume of consumed 0.1 N titanium trichloride will be about 20 mL, and proceed as directed under Assay (1) in the Coloring Matter Aluminum Lake Tests.

1 mL of 0.1 N titanium trichloride = 13.46 mg of $C_{20}H_{14}O_{10}N_2S_3$

Food Red No.3



Chemical Formula: $C_{20}H_6O_5I_4Na_2 \cdot H_2O$

Molecular Weight: 897.91

INS No.: 127

Synonyms: Erythrosine; CI food red 14

CAS No.: 16423-68-0

Definition Food Red No. 3 consists principally of the disodium salt of 2',4',5',7'-tetraiodofluorocene mono hydrate.

Compositional Specifications of Food Red No.3

Content Food Red No.3 should contain not less than 85.0% of the disodium salt of 2',4',5',7'-tetraiodofluorocene mono hydrate ($C_{20}H_6O_5I_4Na_2 \cdot H_2O$).

Description Food Red No.3 occurs as red to brown powder or granules. It is odorless.

Identification (1) When 0.1 g of Food Red No.3 is dissolved in 100 mL of water, it becomes bluish red color.

(2) 0.1 g of Food Red No.3 is dissolved in 500 mL of 0.02 N ammonium acetate solution, 3 mL of which is diluted to 200 mL with 0.02 N ammonium acetate solution. The resulting solution exhibits absorption maximum at a wavelength of 526 ± 2 nm.

(3) When 1 mL of hydrochloric acid is added to 5 mL of Food Red No.3 solution (1→1,000), precipitates are formed.

(4) When 0.1 g of Food Red No.3 is dissolved in 10 mL of sulfuric acid, it becomes yellowish brown color. When 2~3 drops of this solution is added to 5 mL of water, orange red precipitates are formed.

Purity (1) Water-Insoluble Substances : When Food Red No.3 is proceeded as directed under Water-Insoluble Substance in the Coloring Matter Test, the content should not be more than 0.2%.

(2) pH : pH of Food Red No.3 solution (1→100) should be within a range of 6.5~10.0.

(3) Chloride and sulfate : When Food Red No.3 is proceeded as directed under Chloride and sulfate in the Coloring Matter Test, the total content should not be more than 2%.

(4) Arsenic : It should be no more than 4.0 ppm tested by Arsenic Limit Test.

(5) Zinc : When Food Red No.3 is proceeded as directed under Heavy Metals (1) in the Coloring Matter Test, the content should not be more than 50 ppm. In this case, 10 mL of test solution and blank test solution are taken.

- (6) Lead : When 5.0 g of Food Red No.3 is tested by Atomic Absorption Spectrophotometry or Inductively Coupled Plasma Emission Spectroscopy, its content should not be more than 2.0 ppm.
- (7) Cadmium : When 5.0 g of Food Red No.3 is tested by Atomic Absorption Spectrophotometry or Inductively Coupled Plasma Emission Spectroscopy, its content should not be more than 1.0 ppm.
- (8) Mercury : When Food Red No.3 is tested by Mercury Limit Test, its content should not be more than 1.0 ppm.
- (9) Other Coloring Matters : Proceed as directed under Purity (9) in 「Food Green No.3」. In this case, a 1:1 mixture of 25% alcohol and 5% ammonia solution is used as a developing solvent.

Loss on Drying Food Red No.3 is dried for 6 hours at 135°C and the weight loss should not be more than 12%.

Assay Accurately weigh about 1 g of Food Red No.3, and dissolve it in water to make exactly 100 mL. Measure exactly 50 mL of this solution, use it as the test solution, and proceed as directed under (2) Weight Method in the Assay in the Coloring Matter Tests.

$$\text{Content of Food Red No.3} = \frac{\text{Weight of the precipitate(g)} \times 2.148}{\text{weight of the sample(g)}} \times 100$$

Food Red No.40

Allura Red



Chemical Formula: $C_{18}H_{14}O_8N_2S_2Na_2$

Molecular Weight: 496.43

INS No.: 129

Synonyms: Allura red; CI food red 17

CAS No.: 25956-17-6

Definition Food Red No.40 is obtained by coupling diazotized 4-amino-5-methoxy-2-methylbenzenesulfonic acid with 6-hydroxy-2-naphthalenesulfonic acid, salting out, and refining. It consists principally of the disodium salt of 6-hydroxy-5-(2-methoxy-5-methyl-4-sulfophenylazo)-2-naphthalenesulfonic acid.

Compositional Specifications of Food Red No.40

Content Food Red No.40 should contain not less than 85.0% of the disodium salt of 6-hydroxy-5-(2-methoxy-5-methyl-4-sulfophenyl)azo-2-naphthalenesulfonic acid ($C_{18}H_{14}O_8N_2S_2Na_2$)

Description Food Red No.40 occurs as dark red power or granules. It is odorless.

Identification (1) When 0.1 g of Food Red No.40 is dissolved in 100 mL of water, the resulting solution becomes red color.

(2) 0.1 g of Food Red No.40 is dissolved in 100 mL of 0.02 N ammonium acetate solution, 1 mL of which is diluted to 100 mL with 0.02 N ammonium acetate solution. The resulting solution exhibits absorption maximum at a wavelength of 497~501 nm.

(3) When 0.1 g of Food Red No.40 is dissolved in 10 mL of sulfuric acid, it becomes reddish violet color. When 2~3 drops of this solution are added to 5 mL of water, it becomes red color.

Purity (1) Water Insoluble : When Food Red No.40 is proceeded as directed under Water-Insoluble Substance in the Coloring Matter Test, the content should not be more than 0.2%

(2) Chloride and Sulfate : When Food Red No.40 is proceeded as directed under Chloride and Sulfate in the Coloring Matter Test, the content should not be more than 5.0% as total amount

(3) Arsenic : It should be no more than 4.0 ppm tested by Arsenic Limit Test.

(4) Lead : When 5.0 g of Food Red No.40 is tested by Atomic Absorption Spectrophotometry or Inductively Coupled Plasma Emission Spectroscopy, its content should not be more than 2.0 ppm.

(5) Cadmium : When 5.0 g of Food Red No.40 is tested by Atomic Absorption Spectrophotometry or Inductively Coupled Plasma Emission Spectroscopy, its content should not be more than 1.0 ppm.

(6) Mercury : When Food Red No.40 is tested by Mercury Limit Test, its content should not be more

than 1.0 ppm.

- (7) Lower Sulfonated Subsidiary Colors : 10.0 mg of Food Red No.40 is dissolved in ammonium acetate solution (7.7→1000) to make 100 mL as the Test Solution. Separately, cresidine sulfonic acid azo β-naphthol color [4-(2-Hydroxy-1-naphthylazo)-5-methoxy-2-methyl-4-benzenesulfonic acid monosodium salt] and cresidine azo Schaeffer's salt color [6-Hydroxy-5-(2-methoxy-5-methylphenylazo)-2-naphthalenesulfonate monosodium salt] are dried for 24 hours in a vacuum desiccator. 10 mg each of these colors is dissolved in ammonium acetate solution (7.7→1,000) to make exactly 100 mL as the standard stock solution. Using these solutions, when the content of each colors (cresidine sulfonic acid azo β-naphthol colors and cresidine azo Schaeffer's salt colors) in the Test Solution is proceeded as directed under E. Subsidiary Colors in the Tar Coloring Matter Test, the content sum of two should not be more than 1.0 %.
- (8) Higher Sulfonated Subsidiary Colors : Use 20 µl of the Test Solution in (7) Purity as the Test Solution. Separately, cresidine sulfonic acid azo G colors [7-Hydroxy-8-(2-methoxy-5-methyl-4-sulfonatephenylazo)-1,3-naphthalene- disulfonic acid trisodium salt] and cresidine sulfonic acid azo R color [3-Hydroxy-4-(2-methoxy-5-methyl-4-sulfonatephenylazo)-2,7-naphthalenedisulfonic acid trisodium salt] are dried for 24 hours in a vacuum desiccator. 10 mg each of these colors is dissolved in ammonium acetate solution (7.7→1,000) to make exactly 100 mL as the standard stock solution. Using these solutions, when the content of each colors (cresidine sulfonic acid azo G and R colors) in Test Solution is proceeded as directed under E. Subsidiary Colors in the Tar Coloring Matter Test, the content sum of two should not be more than 1.0 %.
- (9) Disodium salt 6-hydroxy(2-naphthalenesulfonate) : Use 20 µl of Test Solution in (7) Purity as the Test Solution. Separately, Disodium 6-hydroxy(2-naphthalene- sulfonate) is dried for 24 hours in a vacuum desiccator. 10.0 mg of dried material is dissolved in ammonium acetate solution (7.7→1,000) to make 100 mL as the standard stock solution. Using this solution, when the content of Disodium 6-hydroxy(2-naphthalenesulfonate) in Test Solution is proceeded as directed under F. Unreacted Raw Material and Reaction Intermediate in the Tar Coloring Matter, the content should not be more than 0.3%.
- (10) 4-Amino-5-methoxy-2-methylbenzene sulfonic acid : Use 20 µl of Test Solution in (7) Purity as the Test Solution. Separately, 10.0 mg of 4-Amino-5-methoxy-2-methylbenzenesulfonic acid is dried for 24 hours in a vacuum desiccator. 100 mg of dried material is dissolved in ammonium acetate solution (7.7→1,000) to make 100 mL as the standard stock solution. Using this solution, when the content of 4-Amino-5-methoxy-2- methylbenzenesulfonic acid in Test Solution is proceeded as directed under F. Unreacted Raw Material and Reaction Intermediate in the Tar Coloring Matter Test, the content should not be more than 0.2%.
- (11) Disodium salt 6,6'-oxybis(2-naphthalenesulfonate) : Use 20 µl of Test Solution in (7) Purity as the Test Solution. Separately, Disodium 6,6'-oxybis(2-naphthalene- sulfonate) is dried for 24 hours in a vacuum desiccator. 10.0 mg of dried material is dissolved in ammonium acetate solution (7.7→1,000) to make 100 mL as the standard solution. Using this solution, when the content of Disodium 6,6'-

oxybis(2-naphthalenesulfonate) in Test Solution is proceeded as directed under F. Unreacted Raw Material and Reaction Intermediate in the Tar Coloring Matter, the content should not be more than 1.0%.

(12) Unulfonated Primary Aromatic Amines : When Food Red No.4 is proceeded as directed under G. Unulfonated Primary Aromatic Amines in Coloring Matter Test, the content should not be more than 0.01 % as aniline

Loss on Drying When Food Red No.40 is dried for 6 hours at 135°C, the weight loss should not be more than 10 %.

Assay Accurately weigh about 1.7 g of Food Red No. 40, and dissolve it in water to make exactly 250 mL. Measure 50 mL of this solution to use as the test solution, and proceed as directed under Titanium Trichloride Method (A) of Assay in Coloring Matter Tests.

1 mL of 0.1 N Titanium trichloride = 12.41 mg $C_{18}H_{14}O_8N_2S_2Na_2$

Food Red No.40 Aluminium Lake

Synonyms: Allura red AC aluminium lake

Definition Food Red No.40 Aluminum Lake is prepared by reacting an aluminum salt solution with alkali, making the reaction product adsorb food Red No.40, filtering, drying, and crushing.

Compositional Specifications of Food Red No.40 Aluminum Lake

Content Food Red No.40 Aluminum Lake should contain not less than 10.0 % of 6-hydroxy-5-(2-methoxy-5-methyl-4-sulfophenylazo)-2-naphthalenesulfonic acid ($C_{18}H_{16}N_2O_8S_2$).

Description Food Red No.40 Aluminum Lake occurs as an orange red fine powder. It is odorless.

Identification (1) To 0.1 g of Food Red No.40 Aluminum Lake, add 5 mL of sulfuric acid. While shaking occasionally, it is heated for 5 minutes in a water bath. The solution becomes dark reddish violet color. After cooling, 2 ~ 3 drops of the supernatant are added to 5 mL of water. This solution becomes red color.

(2) To 0.1 g of Food Red No.40 Aluminum Lake, add 5 mL of diluted sulfuric acid. Where 0.02 N ammonium acetate solution is added to make the total volume to 100 mL. When this solution is not clear, it is centrifuged. 1 ~ 10 mL of this solution is diluted to 100 mL with 0.02 N ammonium acetate solution so that the absorbance to be measured will be within a range of 0.2 to 0.7. This solution exhibits absorption maximum at a wavelength of 497 ~ 501 nm.

(3) To 0.1 g of Food Red No.40 Aluminum Lake, add 10 mL of diluted hydrochloric acid, heat in a water bath until most of it dissolves, add 0.5 g of active carbon, shake well. and filter. The colorless filtrate neutralize with sodium hydroxide solution (1→10). The solution responds to the test for Aluminum Salt in Identification.

Purity (1) Hydrochloric Acid and Ammonia Insoluble Substances : When Food Red No.40 Aluminum Lake is proceeded as directed under Hydrochloric acid-and ammonia-insoluble substances in the Coloring Matter Aluminum Lake Test, the content should not be more than 0.5%.

(2) Arsenic : It should be no more than 4.0 ppm tested by Arsenic Limit Test.

(3) Lead : When 5.0 g of Food Red No.40 Aluminum Lake is tested by Atomic Absorption Spectrophotometry or Inductively Coupled Plasma Emission Spectroscopy, its content should not be more than 5.0 ppm.

(4) Barium : When Food Red No.40 Aluminum Lake is proceeded as directed under Barium in the Coloring Matter Aluminum Lake Test, it should be appropriate (not more than 500 ppm as Ba).

(5) Lower Sulfonated Subsidiary Colors : 0.1 g of Food Red No 40 Aluminum Lake is dissolved in 5 mL diluted sulfuric acid, where ammonium acetate solution (7.7→1000) is added to make 100 mL as the

- Test Solution. If the solution is not clear, it is centrifuged. It is proceeded as directed under Purity (7) in 「Food Red No. 40」, and the content should not be more than 1.0% (based on 85.0% content).
- (6) Higher Sulfonated Subsidiary Colors : Use 20 μ l of the test solution in (5) as the Test Solution. Proceed as directed under Purity (8) in 「Food Red No.40」, and the content should not be more than 1.0% (based on 85.0% content).
- (7) Sodium Salt of 6-Hydroxy-2-Naphthalenesulfonic Acid : Use 20 μ l of the test solution in (5) as the Test Solution. Proceed as directed under Purity (9) in 「Food Red No. 40」, and the content should not be more than 0.3% (based on 85.0% content).
- (8) 4-Amino-5-methoxy-2-methylbenzenesulfonic acid : Use 20 μ l of the test solution in (5) as the Test Solution. It is tested by the procedure in Purity (10) in 「Food Red No.40」, and the content should not be more than 0.2% (based on 85.0 % content).
- (9) Disodium salt of 6,6'-oxybis(2-naphthalenesulfonic acid) : Use 20 μ l of the test solution in (5) as the Test Solution. It is tested by the procedure in Purity (11) in 「Food Red No.40」, and the content should not be more than 1.0% (based on 85.0% content).
- (10) Unsulfonated primary aromatic amines : Weigh 5.0 g of Food Red No.40 Aluminum Lake, add 70 mL of chloroform, set-aside for 1 hour while shaking occasionally. Filter through a dried filter paper (5C) for quantitative analysis and place the filtrate into a 200 mL round bottom flask. Wash three times the residue with 10 mL of chloroform each, combine the filtrate with the washings, and add 5 mL of sulfuric acid (0.15 \rightarrow 1,000). Proceed as directed under Purity (12) in 「Food Red No.40」, and the content should not be more than 0.01% as aniline (based on 85.0% content).

Loss on Drying

When Food Red No.40 Aluminum Lake is dried for 6 hours at 135°C, the weight loss should not be more than 30%

Assay

Accurately weigh Food Red No.40 Aluminum Lake so that the volume of consumed 0.1 N titanium trichloride will be about 20 mL, and proceed as directed under Assay (1) in the Coloring Matter Aluminum Lake Tests.

$$1 \text{ mL of } 0.1 \text{ N titanium trichloride} = 12.411 \text{ mg } \text{C}_{18}\text{H}_{14}\text{O}_8\text{N}_2\text{S}_2\text{Na}_2$$

Food Starch Modified

Synonyms: Modified food starch

INS No.: 1404, 1410 1412, 1413,
1414, 1420, 1422, 1440,
1442, 1450

Definition Food Starch Modified is a modification of starch, which derived from various grains and rootstocks. Physical characteristics of starch are modified by chemical modification (reaction between hydroxyl group in starch and reactant) or by gelatinization. In this category, Oxidized Starch, Acetylated Distarch Adipate, Acetylated Distarch Phosphate, Starch Sodium Octenyl Succinate, Distarch Phosphate, Monostarch Phosphate, Phosphated Distarch Phosphate, Starch Acetate, Hydroxypropyl Distarch Phosphate, and Hydroxypropyl Starch are included. Reaction of formation for each material is as follows.

Oxidized Starch	Oxidation reaction by sodium hypochlorite
AcetylatedDistarch Adipate	Esterification reaction by anhydrousadipic acid and anhydrous acetic acid
Acetylated Distarch Phosphate	Esterification reaction by phosphorous trichloride or sodium trimetaphosphate and anhydrous acetic acid or vinyl acetate
Starch Sodium Octenyl Succinate	Esterification by anhydrous octenyl succinate
Distarch Phosphate	Esterification reaction by phosphorous oxychloride or sodium metaphosphate, tribasic
Monostarch Phosphate	Starch phosphate and distarch phosphate reaction
Phosphated Distarch Phosphate	Esterification reaction by sodium tripolyphosphate and sodium trimetaphosphate
Starch Acetate	Esterification reaction by anhydrous acetic acid or vinyl acetate
Hydroxypropyl Distarch Phosphate	Esterification reaction by phosphorous trichloride or sodium trimetaphosphate or propylene oxide

Compositional Specifications of Food Starch Modified

Description Food Starch Modified is white or almost white powder or granule. Gelatinized form is crumb, amorphous powder, or coarse granule without scent and flavor.

Identification (1) 1 g of Food Starch Modified is suspended in 20 mL of water. Upon adding a few drops of iodine solution, the suspension turns dark blue ~ red.

(2) 2.5 g of Modified Food Starch is transferred into a flask and then mixed with 10 mL of 3% hydrochloric acid and 70 mL of water by shaking. This is then heated for 3 hours in a water bath equipped with a cooling apparatus. When 0.5 mL of this liquid (after cooling) is added to 5 mL of Fehling solution, significant amount of red precipitates are formed.

(3) 50 mg of Food Starch Modified is suspended in 25 mL of 1% methylene blue solution by stirring occasionally. Excess supernatant is discarded and the starch is washed with water. When this is observed with optical microscope, it is colored (for oxidized starch only).

(4) 10 g of Food Starch Modified is suspended in 25 mL of water and 20 mL of 0.4 N sodium hydroxide solution 20 mL is added. After shaking for 1 hour, it is then filtered and the filtrate is evaporated at 110°C in a drier. The residue is dissolved in a few drops of water, which is then transferred into a test tube. Calcium hydroxide is added to the test tube, which is then heated. Acetone vapor evolves upon heating. This vapor turns a filter paper, which is wetted with saturated o-nitrobenzaldehyde solution, blue. When a drop of diluted hydrochloric acid (1→10) is dropped on the paper, yellow color of o-nitrobenzaldehyde saturated solution disappears, which makes the blue color more distinctive. (This is applicable only for acetylated distarch adipate, acetylated distarch phosphate, and starch acetate)

Saturated o-Nitrobenzaldehyde solution : o-Nitrobenzaldehyde is dissolved in 2 N sodium hydroxide solution to saturation. This is prepared freshly before use.

(5) Infrared absorption spectrum of Food Starch Modified is obtained using Infrared Spectrophotometry (1) Potassium Bromide Disk Method. Absorption band for ester group is located approximately at 1720 cm^{-1} . Detection limit is approximately 0.5% for acetyl, adipyl, and succinyl groups (This is applicable only for acetylated distarch adipate, acetylated distarch phosphate, starch sodium octenyl succinate, and starch acetate).

Purity (1) Arsenic : It should be no more than 4.0 ppm tested by Arsenic Limit Test.

(2) Lead : When 5.0 g of Food Starch Modified is tested by Atomic Absorption Spectrophotometry or Inductively Coupled Plasma Emission Spectroscopy, its content should not be more than 2.0 ppm.

(3) Sulfur Dioxide : 30 g of Modified Food Starch is tested according to Purity (7) for 「Caramel」. The content of sulfur dioxide is obtained by titrating with 0.01 N sodium hydroxide solution using the following equation. The content should not be more than 50 ppm.

$$\text{Content of Sulfur Dioxide(ppm)} = \frac{(S - B) \times 32.02 \times 10}{\text{weight of the sample(g)}}$$

(4) Adipic Group : When Modified Food Starch is tested for adipic group according the following test method, the amount of adipic group should not be more than 0.135% (This applies only for acetylated starch adipate).

Total Adipate Salt : 1 g of Modified Food Starch is precisely weighed into a 250 mL Erlenmeyer flask and 50 mL of water and 1 mL of 0.1% glutaric acid are added, which is then shaken so that the starch is well dispersed. 50 mL of 4 N sodium hydroxide solution is added to this suspension, which is shaken for 5 minutes. 20 mL of 12 N hydrochloric acid is carefully added and the resulting mixture is cooled and then transferred into a 250 mL separatory funnel with a stop cock. 100 mL of ethyl acetate is extracted three times. The solvent layer is collected into a Erlenmeyer flask, where 20 g of anhydrous sodium sulfate transfer into advance. This is then shaken periodically for 10 minutes, which is then filtered through a Whatman No.1 filter paper. The Erlenmeyer flask and the residue are washed twice with 50 mL of ethyl acetate. The resultant is vacuum dried (50 mmHg) as quickly as possible at a temperature of 40°C or lower. This needs to be carried out quickly since ethyl acetate may be hydrolyzed. Hydrolyzed ethyl acetate may affect the analysis of the adipate. After it is completely dried, 2 mL of pyridine and 1 mL of N,N-bis-trimethyl-silyl-trifluoro acetamide are added and stopper is placed. The mixture is slowly shaken so that the content is completely wetted and settled for 1 hour. This liquid is transferred into a small vial and 4 µl of it is injected into a gas chromatography.

Free Adipate : 5.0 g of Food Starch Modified is precisely weighed into a 250 mL Erlenmeyer flask. 100 mL of water and 1.0 mL of 0.1% glutaric acid solution are added and the resultant is transferred into a 250 mL separatory funnel with a stop cock. The rest of the procedure is the same as in Total Adipate Salt. The content of total acetate salt or free adipate is calculated from the following equation.

$$\text{Content of total adipate or free adipate(\%)} = \frac{A}{\text{weight of the sample(g)} \times 10}$$

A : The amount of adipate in test solution(mg) obtained from standard calibration curve

The content of adipate(\%) = Content of total adipate(\%) - Content of free adipate(\%)

Standard Calibration Curve : Each 1.0 g of corn starch is transferred 4 Erlenmeyer flasks and 0.1% of 1 mL glutaric acid are added to each flask, respectively. 0.25, 0.5, 0.75, and 1.0 mL of adipic acid standard solution are added to each flask, respectively. Each flask is sufficiently shaken so that the starch is well dispersed. The rest of the procedure is the same as in Total Adipate Salt. The areas of the peaks for adipic acid and glutaric acid are measured. A standard reference curve is obtained for the ratio of area (area of adipic acid peak / area of glutaric acid peak) vs. the amount of adipic acid (mg).

The standard solution of adipic acid : 1.00 g of adipic acid is dissolved in 900 mL of warm water. After cooling, the total volume is brought up to 1,000 mL by adding water.

Operation Conditions

- Column : A stainless tube with inner diameter of 1.83 mm and length of 2 m
- Column Filler : 80~100 Mesh Chromosorb GAW-DMCS coated with 5% OV-17 or its equivalent
- Detector : Hydrogen Flame Ionization Detector (FID)
- Temperature at injection hole : 280°C
- Column Temperature : 140°C
- Detector Temperature : 250°C
- Carrier gas and flow rate : Nitrogen, 30 mL per minute

(5) Acetyl Group : 5 g of Food Starch Modified is precisely weighed into a 200 mL Erlenmeyer flask and dispersed with 50 mL of water. Using phenolphthalein solution as an indicator, the suspension is titrated with 0.1 N sodium hydroxide solution until pale red color persists. After adding 25 mL of 0.45 N sodium hydroxide solution, a stopper is placed and the flask is shaken for 30 minutes at a temperature of 30°C or lower. The stopper and the flask are rinsed with water. Excess alkali inside the flask is titrated with 0.2 N hydrochloric acid until the pale red color disappears. The amount of 0.2 N hydrochloric acid consumed is S. A blank test is carried out with 25 mL of 0.45 N sodium hydroxide solution, where the amount of 0.2 N hydrochloric acid consumed is B. The amount of acetyl group is calculated from the following equation and it should not be more than 2.5% (This only applies to acetylated distarch adipate, acetylated distarch phosphate, and starch acetate).

$$\text{Content of acetyl group(\%)} = \frac{(B-S) \times F \times 0.0086}{\text{weight of the sample(g)}} \times 100$$

(6) Degree of Substitution of Starch Sodium Octenyl Succinate : 5 g of Food Starch Modified is transferred into a 150 mL beaker and thoroughly wetted with a few mL of isopropyl alcohol. Beaker wall is washed down with 25 mL of 2.5 N solution of hydrochloric acid in isopropyl alcohol. It is well mixed for 30 minutes. It is then mixed for 10 minutes with additional 100 mL of 90% isopropyl alcohol. The suspension is filtered through a Buchner funnel. 1 mL of 1% silver nitrate solution is added to the filtrate. The residue is washed with 90% isopropyl alcohol until turbidity or precipitates do not persist over 1 minute. The residue is transferred into a 600 mL beaker and water is added to bring the total volume to 300 mL, which is then heated for 10 minutes in a water bath while stirring. While still hot, it is titrated with 0.1 N sodium hydroxide solution using phenolphthalein as an indicator. The degree of substitution is calculated using the following equation and it should not be more than 0.02 (This is applicable only for starch sodium octenyl succinate).

$$\text{Degree of Substitution(DS)} = \frac{0.162A}{1 - 0.210A}$$

A : Milli-equivalent of sodium hydroxide required for 1 g of starch sodium octenyl succinate

$$A = \frac{0.1N \text{ sodium hydroxide solution consumed(mL)} \times 0.1}{\text{weight of the sample(g)}}$$

(7) Phosphate (as phosphorous) : 10 g of dried material as obtained from the procedure below is transferred into a silica crucible. It is thoroughly wetted with 10 mL of zinc acetate solution, which is then evaporated to dryness on a hot plate and carbonized by further heat treatment. It is then reduced to ash at 550°C. Ash is wetted with 15 mL of water and the crucible wall is rinsed with 5 mL nitric acid. The crucible is heated to boil and then cooled. The content is transferred to a 200 mL flask. The crucible is rinsed with 20 mL of water three times and the rinse water is added to the flask. V (mL) of this solution, which should not be more than 1.5 mg of phosphorus, is taken into a 100 mL flask. 50 mL of water is added to a 100 mL flask for a blank test. To each flask, 10 mL of diluted nitric acid, 10 mL of ammonium vanadate solution, and 10 mL of ammonium molybdate are added sequentially and respectively. After mixing thoroughly, water is added to bring the volume to 100 mL and the resulting solution is settled for 10 minutes. Using the blank test solution as a reference, optical absorption is measured at 460nm with a 1 cm path length. The amount of phosphorus (%) is calculated using the following equation using the content of phosphorus a (mg/100mL) from a standard calibration curve. Specifications are as follows.

Monostarch Phosphate	Not more than 0.5%(Potato and wheat starch)	Not more than 0.04%(Others)
Distarch Phosphate	Not more than 0.14%(")	Not more than 0.04%(")
Phosphated Distarch Phosphate	Not more than 0.5%(")	Not more than 0.4%(")
Acetylated Distarch Phosphate	Not more than 0.14%(")	Not more than 0.04%(")
Hydroxypropyl Distarch Phosphate	Not more than 0.14%(")	Not more than 0.04%(")

$$\text{Content of Phosphorus(\%)} = \frac{a \times 200 \times 100}{\text{weight of dried material(mg)} \times V} \times \frac{S}{W}$$

Sample Preparation Procedure : 200 mL mixture of methyl alcohol and water (7:3) is added to 20~25 g(W) of Food Starch Modified and stirred mechanically for 15 minutes. This is vacuum filtered through a glass or Buchner funnel with a medium disc (10~15 μm). Precipitates are rinsed with 200 mL of methyl alcohol and water mixture. Precipitates are dispersed again. Filtering and rinsing process is repeated. The resulting precipitates are dried at a temperature 50°C or lower. This is ground to 20 mesh or finer, which is then vacuum dried for 5 hours at 120°C and 100 mmHg or below. The weight of dried material (S) is obtained. (This procedure is for the starch that is insoluble in cold water. For gelatinized or other water soluble starch, it is prepared as 1 ~ 2% aqueous paste. This transfer into a cellophane tube and dialyzed for 30 ~ 40 hours while replacing water. Starch is precipitated by stir-mixing in acetone with a 4 times volume of dialyzed paste. This is vacuum filtered through a glass or Buchner funnel with a medium disc (10~15 μm) and rinsed with ethyl alcohol. The amount of dried material is obtained following the procedure for insoluble starch as described above.)

Standard Calibration Curve : 5, 10, and 15 mL of phosphorus standard solution is added to each of three 100 mL volumetric flasks. To each flask and a blank 100 mL volumetric flask, 10 mL of diluted nitric acid, 10 mL of ammonium vanadate solution, and 10 mL of ammonium molybdate are added sequentially and respectively. After mixing thoroughly, water is added to bring the volume to 100 mL and the resulting solution is settled for 10 minutes. Using the blank test solution as a reference, optical absorption is measured at 460 nm with a 1 cm path length. Standard calibration curve is prepared with absorption vs. phosphorus concentration (mg/100mL).

Solutions

- Ammonium Molybdate Solution (5%) : Ammonium molybdate (4 hydrate) is dissolved in 900 mL of warm water. After cooling, additional water is added to bring the total volume to 1000 mL.
 - Ammonium Vanadate Solution (0.25%) : 2.5 g of ammonium meta vanadate is dissolved in 600 mL of boiling water. The solution is then cooled to 60~70°C and 20 mL of nitric acid is added. After cooling to normal temperature, water is added to bring the total volume to 1,000 mL.
 - Zinc Acetate Solution (10%) : 120 g of zinc acetate (2 hydrate) is added in 880 mL of water. Prior to use, the solution is filtered through a Whatman No.2 V filter paper or its equivalent.
 - Diluted Nitric Acid (29%) : 300 mL of nitric acid (specific gravity 1.42) is added to 600 mL of water.
 - Phosphorus Standard Solution : 438.7 mg of mono potassium phosphate is dissolved in water and the total volume is brought up to 1,000 mL. (100 μg P/mL).
- (8) Vinyl Acetate : 30 g of Food Starch Modified is weighed and transferred into a 100 mL flask. The flask is tightly sealed with a septum. This solution and a standard solution are kept in a 70°C water bath for 30 minutes. 2.0 mL of gas is extracted using gas-tight syringe from head-space of each flask and injected into gas chromatography. The content of vinyl acetate is calculated using the following equation and should not be more than 0.1 ppm. (This is applicable only for acetylated distarch phosphate).

$$\text{The content of vinyl acetate(ppm)} = 150 \times \frac{A}{S} \times \frac{1}{\text{weight of the sample(g)}}$$

A : Peak area of test solution

S : Peak area of standard solution

150 : Amount of vinyl acetate in standard solution (μg)

Preparation of Standard Solution : Water is added to 150 mg of vinyl acetate to bring the total volume to 100 mL. Water is added to 1 mL of this solution so that the total volume becomes 10 mL (0.15 mg/mL). 1 mL of the resulting solution is added to 30 g of unmodified starch from the same raw material. Then the container is tightly sealed with a septum.

Operation Conditions

- Column : A glass tube with inner diameter of 2 mm and length of 2 m
- Column Filler : Porapak Q or its equivalent
- Detector : Hydrogen Flame Ionization Detector (FID)
- Temperature at injection hole: 200°C
- Column Temperature : 150°C
- Detector Temperature : 200°C
- Carrier gas and flow rate : Nitrogen, 20 mL per minute

(9) Carboxyl Group : Food Starch Modified is sieved through 20 mesh or finer screen. 0.25 meq (milliequivalent number) of Food Starch Modified (5 g for weakly oxidized, 0.15 g for strongly oxidized) is precisely weighed into a beaker. 25 mL of 0.1 N hydrochloric acid added and stirred occasionally for 30 minutes. This is vacuum filtered through a glass wool filter paper with a medium pore size (10~20 μm). 1 mL of 1% silver nitrate solution is added to 5 mL of the filtrate. It is then washed with water (generally 300 mL) until turbidity or precipitates do not persist for 1 minutes. The residue is transferred into a beaker and heated in a water bath until it is gelatinized. It is further heated for 15 minutes to ensure that gelatinization is complete. While hot, it is titrated with sodium hydroxide solution using phenolphthalein solution as an indicator. The amount of 0.1 N sodium hydroxide solution is S. A blank test is carried out with the same amount of sample. 10 mL of water is added and stirred in 5 minute interval for 30 minutes, which is then vacuum filtered. It is then rinsed with 200 mL of water. The residue is processed further following the same procedure and the consumed amount of sodium hydroxide is obtained. The content of carboxyl group is obtained using the following equation and it should not be more than 1.1% (it is applicable only for oxidized starch).

$$\text{Carboxyl Group(\%)} = \frac{(S - B) \times 0.0045 \times 100}{\text{weight of the sample(g)}}$$

For potato starch, the amount of Phosphate is subtracted using the amount of phosphorus (P in %).

$$\frac{2 \times 45.02 \times P}{30.97} = 2.907 \times P$$

(10) Propylenechlorohydrine : 50 g of Modified Food Starch is precisely weighed and transferred into a pressurizing bottle. 125 mL of 2 N sulfuric acid is added and stopper is placed. After mixing by shaking, it is heated for 10 minutes in a water bath. It is then shaken again and heated for 15 minutes. After cooling, it is neutralized to pH 7 with 25% sodium hydroxide solution, which is then filtered through Whatman No.1 filter paper. The filter paper and the bottle is rinsed with 25 mL of water, which is added to the filtrate. 30 g of anhydrous sodium sulfate is completely dissolved in the filtrate using a magnetic stir plate. The solution is transferred to a 500 mL separatory funnel with a stop cock. The container is rinsed with 25 mL of water and the rinse water is added to the funnel. This is then extracted with 50 mL of ether for five times for 5 minutes. Extracts are concentrated to 8 mL using a Kuderna-Danish concentrator in a 50~55°C water bath. Column tube is filled with 10 g of florisil PR (60 ~ 100 mesh), which is previously heat-treated for 16 hours at 130°C, and 1g of anhydrous sodium sulfate is placed on top. The column is wetted with 25 mL of ether. The concentrate is transferred into the column and 25 mL of ether is passed through the column three times. Collected solution is concentrated to 5 mL (test solution). Separately, standard solutions are prepared as follows. 50 g of unmodified corn starch transfer into 5 pressurizing bottles and 125 mL of 2N sulfuric acid is added to each bottle. To each bottle, 0, 0.5, 1, 2, and 5 mL of propylene chlorohydrine standard solution is added, respectively. Each is processed following the same procedure as the test solution. Concentrations (as starch) of these standard solutions correspond to 0, 0.5, 1, 2, 5 mg/kg(ppm). 2µl of both test and standard solutions are injected into gas chromatography and chromatograms (2 peaks per each) are obtained. Standard calibration curve is obtained from the peak area (sum of two different materials) against the concentration (ppm) of the standard solution. The content of propylene chlorohydrine is obtained from the curve and it should not be more than 1 ppm(this is applicable only for hydroxypropyl starch and hydroxypropyl distarch phosphate).

Operation Conditions

- Column : A 3 m × 3.2 mm stainless
- Column Filler : 80~100 Mesh Gas chrom 2 coated with 10% carbowax 20 M or it sequivalent
- Detector : Hydrogen Flame Ionization Detector (FID)
- Temperature at injection hole : 210°C
- Column Temperature : 110°C
- Detector Temperature : 240°C
- Carrier gas and flow rate : Helium, 25 mL per minute

Solution

• Propylenechlorohydrine solution : 50 mg of propylenechlorohydrine (2-chloro-1-propanol which contains 25% of 1-chloro-2-propanol) is precisely weighed and water is added to bring the volume to 100mL. 10mL of this solution is transferred into a measuring flask and then water is added up to 100mL (1mL of this solution contains 50 µg of mixed chlorohydrine).

(11) Hydroxypropyl Group : 50~100 mg of Food Starch Modified is precisely weighed and transferred into a 100 mL volumetric flask and 25 mL of 1 N sulfuric acid is added. As a blank test, unmodified starch, that is derived from the same raw material as the modified starch, is treated exactly the same as above. These two flasks are heat-treated until the contents become solutions in a boiling water bath. After cooling, water is added to bring the volume to 100 mL. Test solution is further diluted, if necessary, so that the amount of hydroxypropyl group should not be more than 4 mg. 1 mL of each solution is transferred into a 25 mL graduated test tube, which is then immersed in cold water. 8 mL of sulfuric acid is added to each test tube and stopper is placed, which is then well mixed and heated for 3 minutes in a boiling water bath. Test tubes are immediately chilled in an ice bath. When the solution is cold, 0.6 mL of ninhydrine solution is added to each test tube and well shaken. Both tubes are set-aside for 100 minutes in a 25°C water bath. Sulfuric acid is added to each tube to bring the total volume to 25 mL. Each tube is turned upside down a few times (but it is not to be shaken). Absorption is immediately measured at 590 nm with 1 cm path length using a blank test solution as a reference. The content of hydroxypropyl group is calculated from the following equation and should not be more than 7.0% (this is applicable only for hydroxypropyl starch and hydroxypropyl distarch phosphate). Test solution is measured in 5 minutes after it is transferred into a cell. Separately, 1 mL of each propylene glycol standard solution (10, 20, 30, 40, and 50 µg/mL) is added to 25 mL graduated test tube and a standard calibration curve is obtained following the same procedure as above.

$$\text{Content of hydroxy propyl group(\%)} = \frac{C \times 0.7763 \times 10 \times D}{\text{weight of the sample(mg)}}$$

C : Amount of propylene glycol obtained from standard calibration curve (µg/mL)

D : Dilution factor

• Inhydrine Solution : 3 g of ninhydrine is dissolved in 100 mL of 5% sodiumbisulfite solution.

Food Yellow No.4

Tartrazine

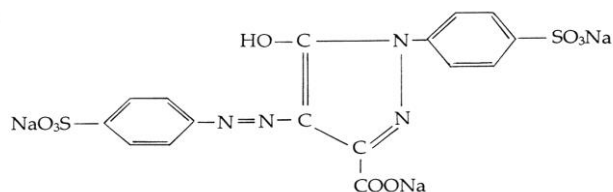

Chemical Formula: $C_{16}H_9O_9N_4S_2Na_3$

Molecular Weight: 534.38

INS No.: 102

Synonyms: Tartrazine; CI food yellow 4

CAS No.: 1934-21-0

Definition Food Yellow No.4 is obtained by coupling diazotized 4-aminobenzenesulfonic acid with 5-hydroxy-1-(4-sulfophenyl)-3-pyrazolecarboxylic acid, followed by salting out, and refining. It consists essentially of the trisodium salt of 5-hydroxy-1-(4-sulfophenyl)-4-(4-sulfophenylazo)-3-pyrazolecarboxylic acid

Compositional Specifications of Food Yellow No.4

Content Food Yellow No.4 should contain not less than 85.0% of the trisodium salt of 3-carboxy-5-hydroxy-1-(4-sulfonatephenyl)-1H-pyrazol-4-azo-4'-(benzene sulfonate) ($C_{16}H_9O_9N_4S_2Na_3$).

Description Food Yellow No.4 occurs as orange-yellow to orange powder or granules. It is odorless.

Identification (1) When 0.1 g of Food Yellow No.4 is dissolved in 100 mL of water, the solution becomes yellow color.

(2) 0.1 g of Food Yellow No.4 is dissolved in 100 mL of 0.02 N ammonium acetate solution. To 1 mL of this solution, add 0.02 N ammonium acetate solution to make 100 mL. The resulting solution exhibits absorption maximum at a wavelength of 428 ± 2 nm.

(3) To 0.1 g of Food Yellow No.4, add 10 mL of sulfuric acid. The solution becomes yellow color. When add 2 ~ 3 drops of this solution to 5 mL of water, this solution becomes yellow color.

Purity (1) Water-Insoluble Substances : When Food Yellow No.4 is proceeded as directed under Water-insoluble substance in Coloring matter Test, the content should not be more than 0.2%.

(2) Chloride and sulfate : When Food Yellow No.4 is proceeded as directed under Chloride and sulfate in Coloring matter Test, the total content should not be more than 6%.

(3) Arsenic : It should be no more than 4.0 ppm tested by Arsenic Limit Test.

(4) Lead : When 5.0 g of Food Blue No.4 is tested by Atomic Absorption Spectrophotometry or Inductively Coupled Plasma Emission Spectroscopy, its content should not be more than 2.0 ppm.

(5) Cadmium : When 5.0 g of Food Blue No.4 is tested by Atomic Absorption Spectrophotometry or Inductively Coupled Plasma Emission Spectroscopy, its content should not be more than 1.0 ppm.

(6) Mercury : When Food Blue No.4 is tested by Mercury Limit Test, its content should not be more than 1.0 ppm.

(7) Unsulfonated Primary Aromatic Amines : When G. Unsulfonated Primary Aromatic Amines in Coloring Matter Tests is done, the content should not be more than 0.01% as Aniline.

(8) Other Coloring Matters : Proceed as directed under Purity (9) in 「Food Green No.3」. In this case, 0.1 g of the sample is dissolved in water to make 100 mL solution.

Loss on Drying When Food Yellow No.4 is dried for 6 hours at 135°C, the weight loss should not be more than 10%.

Assay Accurately weigh about 1.5 g of Food Yellow No.4, and dissolve it in water to make exactly 250 mL. Measure exactly 50 mL of this solution, use it as the test solution, and proceed as directed under Titanium Trichloride Method (C) of Assay in Coloring Matter Tests.

1 mL of 0.1 N titanium trichloride = 13.36 mg of $C_{16}H_9O_9N_4S_2Na_3$

Food Yellow No.4 Aluminium Lake

Synonyms: Tartrazine aluminium lake

Definition Food Yellow No.4 Aluminum Lake is prepared by reacting an aluminum salt solution with alkali, making the reaction product adsorb Food Yellow No.4, filtering, drying, and crushing.

Compositional Specifications of Food Yellow No.4 Aluminum Lake

Content Food Yellow No.4 Aluminum Lake should contain not less than 10.0% of 3-carboxyl-5-hydroxyl-1-(4-sulfophenyl)1H-pyrazol-4-azo-(4'-benzenesulfonate)

($C_{16}H_{12}O_9N_4S_2 = 468.42$).

Description Food Yellow No.4 Aluminum Lake occurs as a fine yellow powder. It is odorless.

Identification (1) To 0.1 g of Food Yellow No.4 Aluminum Lake, add 5 mL of diluted sulfuric acid, where 0.02 N ammonium acetate solution is added to make the total volume to 100 mL. When this solution is not clear, it is centrifuged. 1 ~ 10 mL of this solution is diluted to 100 mL with 0.02 N ammonium acetate solution so that the absorbance to be measured will be within a range of 0.2 ~ 0.7. This solution exhibits absorption maximum at a wavelength of 428 ± 2 nm.

(2) To 0.1 g of Food Yellow No.4 Aluminum Lake, add 5 mL of sulfuric acid. While shaking occasionally, it is heated for 5 minutes in a water bath, and it becomes yellow. After cooling, 2 ~ 3 drops of supernatant are added to 5 mL of water. This solution becomes yellow.

(3) To 0.1 g of Food Yellow No.4 Aluminum Lake is dissolved in 10 mL diluted hydrochloric acid, which is heated in a water bath. Most of the solid material is dissolved. 0.5 g of activated carbon is added and well mixed, which is then filtered. The colorless filtrate is neutralized with sodium hydroxide solution (1→10). It responds to test of aluminum salt in Identification.

Purity (1) Hydrochloric Acid and Ammonia Insoluble Substances: When Food Yellow No.4 Aluminum Lake is proceeded as directed under Hydrochloric Acid and Ammonia Insoluble Substances in Coloring Matter Aluminum Lake Test, the content should not be more than 0.5%

(2) Arsenic : It should be no more than 4.0 ppm tested by Arsenic Limit Test.

(3) Lead : When 5.0 g of Food Yellow No.4 Aluminum Lake is tested by Atomic Absorption Spectrophotometry or Inductively Coupled Plasma Emission Spectroscopy, its content should not be more than 5.0 ppm.

(4) Barium : When Food Yellow No.4 Aluminum Lake is proceeded as directed under Barium in Coloring Matter Aluminum Lake Test, it should be appropriate (not more than 500 ppm as Ba).

(5) Other coloring matters : Proceed as directed under Purity (5) in 「Food Green No.3」. In this case, an amount of sample is used so that it contains 0.1 g as color acid.

Loss on Drying When Food Yellow No.4 Aluminum Lake is dried for 6 hours at 135°C, the weight loss should not be more than 30%.

Assay Accurately weigh Food Yellow No.4 Aluminum Lake so that the volume of consumed 0.1N titanium trichloride will be about 20 mL, and proceed as directed under Assay (3) in Coloring Matter Aluminum Lake Test.

1 mL of 0.1 N titanium trichloride solution = 11.71 mg $C_{16}H_{12}O_9N_4S_2$

Food Yellow No.5

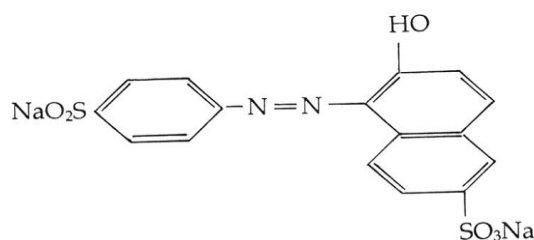

Chemical Formula: $\text{C}_{16}\text{H}_{10}\text{O}_7\text{N}_2\text{S}_2\text{Na}_2$

Molecular Weight: 452.39

INS No.: 110

Synonyms: Sunset yellow FCF; CI food yellow 3

CAS No.: 2783-94-0

Definition Food Yellow No. 5 is obtained by coupling diazotized 4-aminobenzene sulfonic acid with 6-hydroxy-2-naphthalenesulfonic acid, salting out, and refining. It consists principally of the disodium salt of 6-hydroxy-5-(4-sulfophenylazo)-2-naphthalene sulfonic acid.

Compositional Specifications of Food Yellow No. 5

Content Food Yellow No.5 should contain not less than 85.0% of the disodium salt of 2-(hydroxy-6-sulfonatenaphthalene)-1-azo-(4'-benzene sulfonate)($\text{C}_{16}\text{H}_{10}\text{O}_7\text{N}_2\text{S}_2\text{Na}_2$).

Description Food Yellow No.5 occurs as orange-red powder or granules. It is odorless.

Identification (1) When 0.1 g of Food Yellow No.5 is dissolved in 100 mL of water, the solution becomes orange color.

(2) 0.1 g of Food Yellow No.5 is dissolved in 100 mL of 0.02 N ammonium acetate solution. To 1 mL of the solution, add 0.02 N ammonium acetate solution to make 100 mL. The solution exhibits absorption maximum at a wave-length of 483 ± 2 nm.

(3) When 0.1 g of Food Yellow No.5 is dissolved in 10 mL of sulfuric acid. the solution becomes orange red color. When 2 ~ 3 drops of the solution is added to 5 mL of water, it becomes orange yellow color.

Purity (1) Water-Insoluble Substances : When Food Yellow No.5 is proceeded as directed under Water-insoluble substance in Coloring matter Test, the content should not be more than 0.2%.

(2) Chloride and Sulfate : When Food Yellow No.5 is proceeded as directed under Chloride and sulfate in Coloring matter Test, the total content should not be more than 5%.

(3) Arsenic : It should be no more than 4.0 ppm tested by Arsenic Limit Test.

(4) Lead : When 5.0 g of Food Yellow No.5 is tested by Atomic Absorption Spectrophotometry or Inductively Coupled Plasma Emission Spectroscopy, its content should not be more than 2.0 ppm.

(5) Cadmium : When 5.0 g of Food Yellow No.5 is tested by Atomic Absorption Spectrophotometry or

Inductively Coupled Plasma Emission Spectroscopy, its content should not be more than 1.0 ppm.

(6) Mercury : When Food Yellow No.5 is tested by Mercury Limit Test, its content should not be more than 1.0 ppm.

(7) Sudan I(1-phenylazo -2-naphthol) : Accurately weigh 0.2 g of Food Yellow No.5 and transfer it into a 10 mL volumetric flask. Dissolve it in 4 mL of water, add 5 mL of methanol mix and cool. Then water is added to make 10 mL, Test Solution. the test solution is filtered by 0.2 μ m membrane filter made by polytetrafluoro ethylene (PTFE) and liquid chromatography is carried by following operation condition. Separately, filter sudan standard solution with 0.2 μ m membrane filter made by PTFE. And then inject the solution of standard and sample into liquid chromatograph respectively, and prepare a calibration curve. Peak areas or heights acquired from test solution is substituted to the calibration curve and the content of sudan I is determined. This value should not be more than 1.0 ppm.

Operation Condition

-Detector : UV 485 nm

-Column packing materials : 5 μ m octadecyl silyl silicagel for liquid chromatography

-Column Tube : Stainless steel tube with 2.1 mm inner diameter, 15 cm length

-Mobile Phase : Solution A : 20 mM ammonium acetate solution

Solution B : methanol

Solution A : Solution B(50:50) 5 minutes \rightarrow Solution A : Solution B(0:100) 5 min \rightarrow

Solution A : Solution B(0:100) 5 minutes

-Flow Rate : 0.25 mL/min

-Standard solution : Accurately weigh Standard Sudan I and dissolve it in methanol to make 10 ppm. Each 20, 50, 100, 150, 200 and 250 μ l of this solution is transferred into 10 mL volumetric flask, and dissolved in 5 mL of methanol. Then water is added to make 10 mL, respectively. (1 mL of this solution contains 0.02, 0.05, 0.10, 0.15, and 0.20 μ g of Sudan I, respectively.)

(8) Subsidiary Colors : 100.0 mg of Food Yellow No.5 is weighed and dissolved in ammonium acetate solution (1.54 \rightarrow 1000, pH 8.0) to make 100 mL as the Test Solution. Separately, sulfonic acid azo G salt color (1,3-naphthalenedisulfonic acid, 7-hydroxy-8-[4-sulfophenyl] azo, trisodium salt), sulfonic acid azo R salt color (2,7-naphthaleindisulfonic acid, 3-hydroxy-4-[4-sulfophenyl]azo, trisodium salt), sulfonic acid azo-naphthol color, (benzenesulfonic acid, 4-[4-hydroxy-1-naphthalenyl]azo), monosodium salt), and aniline azo Schaeffer's salt color (2-naphthalenesulfonic acid, 6-hydroxy-5(phenylazo), monosodium salt) was dried for 24 hours in a vacuum desiccator. 10 mg each of dried material is dissolved in ammonium acetate solution (1.54 \rightarrow 1000, pH 8.0) to make 100 mL as Standard Solution. Using this solution, when the content of sulfonic acid azo G salt color, sulfonic acid azo R salt color, sulfonic acid azo-naphthol color, and aniline azo Schaeffer's salt color in Test solution is proceeded as directed under Subsidiary Colors in the Tar Coloring Matter test, the content should not be more than 5.0% as total amount. The content sum of colors (except sulfonic acid azo R salt color) should not be more than 2.0%.

Operation Conditions

-Detector : Visible Absorption Detector (wave length 482 nm)

-Mobile Phase: A : Ammonium acetate solution (1.54→1000)

B : Acetonitrile

Solution A : Solution B (100:0) → Solution A : Solution B (60:40) 50 minutes

(9) Unreacted Raw Material and Reaction Intermediate : 100 mg of Food Yellow No. 5 is dissolved in ammonium acetate solution (1.54→1000, pH 8.0) to make precisely 100 mL. This solution is used as the Test Solution. Separately, 4-amino-benzene-sulfonic acid, 7-hydroxy-1,3-naphthalenedisulfonic acid disodium salt, 3-hydroxy-2,7-naphthalene-disulfonic acid disodium salt, 6-hydroxy-2-naphthalenedisulfonic acid monosodium salt, 6,6'-oxybis[2-naphthalenesulfonic acid], and disodium salt of 4,4'-(Diazo amino)-dibenzensulfonic acid was dried for 24 hours in a vacuum desiccator. 10.0 mg each of dried material is dissolved in ammonium acetate solution (1.54→1,000) to make 100 mL as Standard Solution. Using this solution, when the content of 4-aminobenzenesulfonic acid, 7-hydroxy-1,3-naphthalenedisulfonic acid disodium salt, 3-hydroxy-2,7-naphthalene-disulfonic acid disodium salt, 6-hydroxy-2-naphthalenesulfonic acid monosodium salt, 6,6'-oxybis[2-naphthalenesulfonic acid disodium salt], and disodium salt of 4,4'-(diazoamino)dibenzensulfonic acid in Test solution is proceeded as directed under Unreacted Raw Material and Reaction Intermediate in the Coloring Matter Tests, the content should not be more than 0.5% as total mount.

Operation Conditions

-Detector: Visible Absorption Detector (wave length 232 nm, but 358 nm for disodium salt of 4,4'-(diazoamino)-dibenzensulfonic acid)

-Mobile Phase: A : Ammonium acetate solution (1.54→1000)

B : Acetonitrile

Solution A : Solution B (100:0) → Solution A: Solution B (60:40) 50 minutes

(10) Unsulfonated Primary Aromatic Amines : When Food Yellow No.5 is proceeded as directed under Unsulfonated Primary Aromatic Amines in Coloring matter Test , the content should not be more than 0.01% as aniline.

Loss on Drying When Food Yellow No.5 is dried for 6 hours at 135°C, the weight loss should not be more than 10%.

Assay Accurately weigh about 1.3 g of Food Yellow No.5, and dissolve it in water to make exactly 250 mL. Measure exactly 50 mL of this solution, use it as the test solution, and proceed as directed under Titanium Trichloride Method (A) of Assay in Coloring matter Test.

1 mL of 0.1 N titanium trichloride = 11.31 mg of $C_{16}H_{10}O_7N_2S_2Na_2$

Food Yellow No.5 Aluminium Lake

Synonyms: Sunset yellow FCF aluminium lake

Definition Food Yellow No. 5 Aluminum Lake is prepared by reacting an aluminum salt solution with alkali, making the reaction product adsorb Food Yellow No. 5, filtering, drying, and crushing.

Compositional Specifications of Food Yellow No.5 Aluminum Lake

Content Food Yellow No.5 Aluminum Lake should contain not less than 10.0% of 2-hydroxy- 6-sulfo naphthalene-1-azo-(4'-benzene sulfonic acid) ($C_{16}H_{12}N_2O_7S_2 = 408.41$).

Description Food Yellow No.5 Aluminum Lake occurs as a fine, orange-yellow powder. It is odorless.

Identification (1) To 0.1 g of Food Yellow No.5 Aluminum Lake, add 5 mL of diluted sulfuric acid, where 0.02 N ammonium acetate solution is added to make 100 mL. When this solution is not clear, it is centrifuged. 1 ~ 10 mL of this solution is diluted to 100 mL with 0.02 N ammonium acetate solution so that the absorbance to be measured will be within a range of 0.2 to 0.7. The resulting solution exhibits absorption maximum at a wavelength of 482 ± 2 nm.

(2) To 0.1 g of Food Yellow No.5 Aluminum Lake, add 5 mL of sulfuric acid. While shaking occasionally, it is heated for 5 minutes in a water bath. The solution becomes orange red color. After cooling, 2 ~ 3 drops of the supernatant are added to 5 mL of water. This solution becomes orange yellow.

(3) To 0.1 g of Food Yellow No.5 Aluminum Lake, add 10 mL of diluted hydrochloric acid, which is heated in a water bath. Most of the solid material is dissolved. 0.5 g of activated carbon is added and well mixed, which is then filtered. The colorless filtrate is neutralized with sodium hydroxide solution (1→10). It responds to the test for aluminum salt in Identification.

Purity (1) Hydrochloric Acid and Ammonia Insolubles Substances: When Yellow No.5 Aluminum Lake is proceeded as directed under Hydrochloric Acid and Ammonia Insolubles Substances in Coloring Matter Aluminum Lake Test, the content should not be more than 0.5%.

(2) Arsenic : It should be no more than 4.0 ppm tested by Arsenic Limit Test.

(3) Lead : When 5.0 g of Yellow No.5 Aluminum Lake is tested by Atomic Absorption Spectrophotometry or Inductively Coupled Plasma Emission Spectroscopy, its content should not be more than 5.0 ppm.

(4) Barium : When Yellow No.5 Aluminum Lake is proceeded as directed under Barium in Coloring Matter Aluminum Lake Test, it should be appropriate (not more than 500 ppm as Ba).

(5) Other color matters : Proceed as directed under Purity (5) in 「Food Green No.3 Aluminum Lake」. In this case, an amount of sample is used so that it contains 0.1 g as color acid.

Loss on Drying When Yellow No.5 Aluminum Lake is dried for 6 hours at 135°C, the weight loss should not be more than 30%.

Assay Accurately weigh Food Yellow No.5 Aluminum Lake so that the volume of consumed 0.1 N titanium trichloride will be about 20 mL, and proceed as directed under Assay (1) in Coloring Matter Aluminum Lake Test.

1 mL of 0.1 N titanium trichloride = 10.21 mg of $C_{16}H_{12}O_7N_2S_2$

Formic Acid

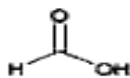

Chemical Formula: CH₂O₂

Molecular Weight: 46.03

Synonyms: Methanoic acid

INS No.: 236

CAS No.: 64-18-6

Compositional Specifications of Formic Acid

Content Formic Acid should not contain less than 85.0% of formic acid (CH₂O₂).

Description Formic Acid is colorless corrosive liquid with characteristic pungent smell.

Identification To 5 mL of Formic Acid, add 2 mL of mercury chloride solution and heat. White crystalline precipitates of mercurous chloride are formed.

Purity (1) Acetic Acid : To 1 mL (approximately 1.2 g) of Formic Acid, add water and to make 100 mL. Take 50 mL of this solution, transfer into a 250 mL distillation flask, and add 5 g of yellow mercury(II) oxide. A reflux condenser is attached and the mixture is boiled for 2 hours while stirring. After cooling, the mixture is filtered and the residue is washed with 25 mL of water. Wash water is added to the filtrate, which is then titrated with 0.02 N sodium hydroxide solution using phenolphthalein solution as an indicator. The consumed amount of sodium hydroxide solution should not be more than 2.0 mL.

(2) Dilution Test : When 1 unit of Formic Acid is diluted with 3 units of water, it should not become turbid within 1 hour.

(3) Sulfate: To 2.4 g of Formic Acid, add 10 mg of sodium carbonate, and evaporate to dryness on water bath. The residue is tested by Sulfate Limit Test Salts. The amount of sulfates should be equal to or less than the amount that corresponds to 0.2 mL of 0.01 N sulfuric acid.

(4) Lead : When 5.0 g of Formic Acid is tested by Atomic Absorption Spectrophotometry or Inductively Coupled Plasma Emission Spectroscopy, its content should not be more than 2.0 ppm.

Assay 15 mL of water is added to a Erlenmeyer flask with a stopper, which is weighed. 1.5 mL of Formic Acid is added to the flask, which is then weighed again. This solution is diluted to 50 mL with water. The resulting solution is titrated with 15 mL of water 1 N sodium hydroxide solution (indicator : phenolphthalein solution).

1 mL of 1 N sodium hydroxide solution = 46.03 mg CH₂O₂

Fumaric Acid



Chemical Formula: C₄H₄O₄

Molecular Weight: 116.07

INS No.: 297

Synonyms: (*E*)-Butenedioic acid; trans-1,2-Ethylenedicarboxylic acid

CAS No.: 110-17-8

Compositional Specifications of Fumaric Acid

Content Fumaric Acid should contain not less than 99.0% of fumaric acid (C₄H₄O₄).

Description Fumaric Acid occurs as a white crystalline powder. It is odorless and has a characteristic acid taste.

Identification (1) Heat Fumaric Acid. It sublimes.

(2) Place 50 mg of Fumaric Acid into a test tube, add 2 ~ 3 mg of resorcinol and 1 mL of sulfuric acid. shake, heat at 120 ~ 130°C for 5 hours, cool, and add water to make 5 mL. While cooling this solution, add drop wise sodium hydroxide solution (2→5) to make it alkaline, and add water to make 10 mL. A green-blue fluorescence appears under ultraviolet light.

(3) To 0.5 g of Fumaric Acid, add 10 mL of water, dissolve by boiling, and add 2 ~ 3 drops of bromine solution while hot. The color of the solution disappears.

(4) Dry Fumaric Acid at 105°C for 3 hours. The melting point is 287 ~ 302°C.

Purity (1) Clarity and Color of Solution : 0.5 g of Fumaric Acid is dissolved in 10 mL of sodium hydroxide solution. This solution should colorless and clear.

(2) Sulfate : Weigh 1 g of Fumaric Acid, add 30 mL of water, shake, add 1 drop of phenolphthalein solution, add drop wise ammonia solution until the color of the solution changes to a slightly pink color, and add 1 mL of dilute hydrochloric acid, Test Solution. When the test solution is tested by Sulfate Limit Test, its content should not be more than the amount corresponding to 0.2 mL of 0.01N sulphuric acid.

(3) Arsenic : It should be no more than 4.0 ppm tested by Arsenic Limit Test.

(4) Lead : When 5.0 g of Fumaric Acid is tested by Atomic Absorption Spectrophotometry or Inductively Coupled Plasma Emission Spectroscopy, its content should not be more than 2.0 ppm.

(5) Mercury : When Fumaric Acid is tested by Mercury Limit Test, its content should not be more than 1.0 ppm.

Residue on Ignition When thermogravimetric analysis is done with Fumaric Acid, the residue should not be more than 0.05%.

Assay Accurately weigh about 1 g of Fumaric Acid, and dissolve in water to make exactly 250 mL.

Measure exactly 25 mL of this solution, and titrate with 0.1 N sodium hydroxide (indicator : 2 drops of phenolphthalein solution).

1 mL of 0.1 N sodium hydroxide = 5.804 mg of $C_4H_4O_4$

Furcelleran

Synonyms: Danish agar

CAS No.: 9000-21-9

Definition Furcelleran is obtained by extracting leaves of *Furcellaria fastigata* HUD. (a red algae) with water or alkaline aqueous solution, and then precipitating of alcohol(ethanol, methanol, isopropyl alcohol), precipitating of potassium or freezing. Main component of Furcelleran is a polysaccharide.

Compositional Specifications of Furcelleran

Description Furcellerane is scentless white ~ pale yellow powder with a slightly salty taste.

Identification (1) 4 g of Furcelleran is stirred in 200 mL of water in approximately 80°C water bath until a viscous liquid is obtained. When this viscous liquid is set aside and cooled to room temperature, it forms a gel.

(2) 0.1 g of Furcelleran is dissolved in 20 mL water. To this solution, 3 mL of barium chloride solution and 5 mL of hydrochloric acid (1→4) are added to form precipitates, which is then filtered. When the filtrate is boiled for 5 minutes, white crystalline precipitates are formed.

Purity (1) Sulfate(SO₄) : Furcelleran is dried for 5 hours at 105°C. Approximately 1 g of the dried material is precisely weighted into a 100 mL round bottom flask, and 50 mL of diluted hydrochloric acid (1→4) is added. A reflux condenser is attached, and heated for 1 hour. 25 mL of hydrogen peroxide is added to the flask, which is then heated again for approximately 5 hours. If necessary, the decomposed solution is filtered. Transfer the filtrate into a beaker. While the filtrate is boiling, 10 mL of barium chloride solution is slowly added to the beaker, which is heated for 2 hours in a water bath. Cool the solution. It is filtered through a quantitative filter paper (5 type C). The residue is washed with warm water until the wash water doesn't show the reaction of chlorides. The residue is dried along with the filter paper, which is then heat treated in a porcelain crucible until the weight becomes constant. The remaining residue is weighted as barium sulfate (B). The content of sulfate (SO₄) is calculated by the following equation. It should be 8.0 ~ 40.0%

$$\text{Content of Sulfate (SO}_2\text{) (\%)(\%)} = \frac{B \times 0.4116}{A} \times 100$$

(2) Arsenic : It should be no more than 4.0 ppm tested by Arsenic Limit Test.

(3) Lead : When 5.0 g of Furcelleran is tested by Atomic Absorption Spectrophotometry or Inductively Coupled Plasma Emission Spectroscopy, its content should not be more than 5.0 ppm.

(4) Residual solvent : 2 g of Furcelleran is precisely weighed into a 300 mL round bottom distilling flask,

200 mL of water is added, boiling chips and 1 mL of silicone resin are added and mixed well. A fractionating column is connected to flask, 4 mL of internal standard solution is precisely weighed and added to it. While adjusting the heat so that the foam does not enter the column, distill the solution at the rate of 2~3 mL per 1 minute until the milky liquid becomes about 90 mL, and water is added to make 100 mL, test solution. However, tert-butyl alcohol (1→1,000) is used as internal standard solution. Separately, 0.5 g each of methyl alcohol and isopropyl alcohol is precisely measured and water is added to 500 mL. Again 2 mL of this solution and 4 mL of internal standard solution is weighed, water is added to make 100 mL, mixed standard solution. 2µl of test solution and mixed standard solution is taken respectively, and injected to gas chromatograph with the following operation condition. Then, Ratio of methyl alcohol and isopropyl alcohol peak area against tert-butyl alcohol peak area, Q_{T1} , Q_{T2} and Q_{S1} , Q_{S2} , is measured respectively, and measure the content of methyl alcohol and isopropyl alcohol under following equation, it should be not more than 0.1% as individual or sum if used together.

$$\text{Content of methyl alcohol(\%)} = \frac{\text{Weight of methyl alcohol(g)}}{\text{Weight of sample(g)}} \times \frac{Q_{T1}}{Q_{S1}} \times \frac{2 \times 100}{500 \times 100} \times 100$$

$$\text{Content of Isopropyl alcohol(\%)} = \frac{\text{Weight of isopropyl alcohol(g)}}{\text{Weight of sample(g)}} \times \frac{Q_{T2}}{Q_{S2}} \times \frac{2 \times 100}{500 \times 100} \times 100$$

Q_{T1} : Ratio of methyl alcohol peak area against tert-butyl alcohol peak area in Test Solution

Q_{T2} : Ratio of isopropyl alcohol peak area against tert-butyl alcohol peak area in Test Solution

Q_{S1} : Ratio of methyl alcohol peak area against tert-butyl alcohol peak area in mixed standard Solution

Q_{S2} : Ratio of isopropyl alcohol peak area against tert-butyl alcohol peak area in mixed standard Solution

Column : PLOT Q or its equivalent

Detector : Hydrogen Flame Ionization Detector (FID)

Injection Port Temperature : 200°C

Column Temperature : 120°C

Detector Temperature : 300°C

Carrier gas : Nitrogen or Helium

Loss on Drying When Furcelleran is dried for 5 hours at 105°C, the weight loss should not be more than 12%.

Ash When Furcelleran is tested by Ash and Acid-Insoluble Ash Limit, it should not be more than 40%.

α-Galactosidase

Definition α-Galactosidase is the enzyme, which is obtained from the culture of *Aspergillus niger*. Diluent or stabilizer can be added for the purpose of activity adjustment and quality preservation.

Compositional Specifications of α-Galactosidase

Description Tannase is a white ~ pale yellow powder.

Identification When α-Galactosidase is proceeded as directed under Activity Test, it should have the activity as α-Galactosidase.

Purity (1) Arsenic : It should be no more than 4.0 ppm tested by Arsenic Limit Test.

(2) Lead : When 5.0 g of α-Galactosidase is tested by Atomic Absorption Spectrophotometry or Inductively Coupled Plasma Emission Spectroscopy, its content should not be more than 5.0 ppm.

(3) Coliform Group: α-Galactosidase is tested by Microbiological Method for (Coliform Group) in General Testing Methods in 「Standards and Specifications for Foods」. It should contain not more than 30 per 1g of this product.

(4) Salmonella : α-Galactosidase is tested by Microbiological Method for [Salmonella] in General Testing Methods in 「Standards and Specifications for Foods」. It should be negative(-).

(5) E. Coli : When α-Galactosidase is tested by Microbe Test Methods for E. Coli in General Test Method 「Standards and Specifications for Foods」, it should be negative (-).

Activity Test (activity) Analysis Principle : The activity test is based on the hydrolysis of p-nitrophenyl-α-D-galactopyranoside substrate for 15minutes at the temperature of 37°C, and pH 5.5.

Enzyme Test Solution : Sample dissolve in water, and 1mL of final diluent solution should be contained 0.001 ~ 0.003 galactosidase unit to prepare Test Solution.

Test Procedure : 2.0 mL of substrate solution is added to a 20 × 150mm test tube and isothermalized for 15 minutes in a 37 ± 0.2°C water bath. In the same condition with Substrate Solution, 1.0 mL of Enzyme Test Solution is precisely added to the test tube, and mixed well. After 15minutes, 5.0 mL of sodium boric acid buffer(pH 9.7) is added in each test tube, and mixed in each test tube. Control is water. Measure the absorbance(A_S) at 405 nm. Separately, for Enzyme blank test, 1 mL of Enzyme Test Solution is taken. Add 5 mL of sodium boric acid buffer, and mix. 2 mL of Substrate Solution is placed in each test tube, and mixed, and conducted the same procedure as Enzyme Test solution by measuring absorbance(A_B) at 405nm. The activity of the enzyme is calculated following the formula.

$$\alpha\text{-Galactosidase(Gal U/g)} = \frac{(A_S - A_B) \times F}{\epsilon \times T \times M}$$

A_S : Absorbance of Test Solution

A_B : Absorbance of Control Solution

F : Dilution factor of Test Solution

T : Reaction Time(min)

M : Weight of sample(g) contained 1mL of Test Solution.

ϵ : Absorbance coefficient measured with standard 4-nitrophenol solution

Definition of Activity : 1 α -Galactosidase unit corresponds to the amount of enzyme, which isolated from 1 μ mol of p-nitrophenol per minutes under the above test conditions

Solutions

Acetic acid buffer solution(pH 5.5)

A Solution : 11.55mL of glacial acetic acid dissolve in 1,000mL water.

B Solution : 16.4g of sodium acetate dissolve in 1,000mL water.

7.5mL of A Solution and 42.5mL of B Solution are mixed, and adjusted to pH 5.5 by using A Solution and B Solution. Add water to make 1,000mL volume.

Substrate solution : 0.0383g of p-nitrophenyl- α -galactopyranoside is mixed to Acetic acid buffer solution, and is diluted to make 100mL volume.

Sodium boric acid buffer solution : 47.63g of Sodium boric acid dissolve in warm water, and cooled into room temperature. Add 20mL of 4N sodium hydroxide. After adjusting until pH 9.7 by using 4N sodium hydroxide, the solution is diluted to 2,000mL.

4-nitrophenol Standard Stock Solution : 4-nitrophenol is dried advance. 68.83mg of 4-nitrophenol is precisely weighted, and dissolved in water to make 1,000mL. 1mL of this solution should contain 0.5 μ mol of nitrophenol.

Standard 4-nitrophenol Solution : Pipet 4mL, 8mL and 16mL of 4-nitrophenol Standard Stock Solution into each test tube, and add water to make 50mL volume. The content of 4-nitrophenol in th diluted solution should be contained each 0.04, 0.08 and 0.16 μ mol per 1mL. After each solution is grouped with five test tubes, and 2.0mL of Substrate Solution is placed in each five test tubes. 1mL of Standard 4-nitrophenol Solution is added in each four test tubes, and 1.0mL of water is added to each fifth test tube instead of Standard 4-nitrophenol Solution. 5.0mL of Sodium boric acid buffer solution is added into each test tube, and mixed. Control solution is water. Absorbance is measured by 1cm of the liquid layer at 405nm, and the curve based on the amount of 4-nitrophenol is prepared. The average absorbance coefficient of Standard 4-nitrophenol Solution is calculated to divide the absorbance of each diluted solution into the concentrate of 4-nitrophenol(μ mol/mL)

$$\varepsilon = A_N/C$$

A_N : The absorbance of Standard 4-nitrophenol Solution

C : The concentrate of 4-nitrophenol

The value of absorbance coefficient should be obtained as an approximation value, 18.3.

Stotage standard of α -Galactosidase

α -Galactosidase should be stored in a hermetic container in a cold dark place.

Gallic Acid

Definition Gallic Acid is obtained by hydrolyzing tannin that is extracted from gallnut of lacquer tree (*Rhus javanica* L.) of anacardiaceae or gall of fagaceae (*Quercus infectoria* ol IV) with water, ethyl alcohol, or organic solvents. Its component is gallic acid.

Compositional Specifications of Gallic Acid

Description Gallic Acid is scentless white ~ whitish yellow needle-shaped crystalline powder with an astringent and a slight acidic taste.

Identification 20 mL of water is added to 1 g of Gallic Acid, which is mixed by shaking for 1 minute and filtered. When 2 ~ 3 drops of ferric chloride solution (1→10) are added to the filtrate, bluish black precipitates are formed.

Purity (1) Clarity of Solution : A solution of 1 g of Gallic Acid in 20 mL of water should be pale yellow and almost clear (or better).

(2) Tannin Acid : 20 mL of water is added to 1 g of Gallic Acid, which is mixed by shaking and filtered. When 5 ~ 6 drops of 1% warm gelatin solution, it should not turn turbid.

(3) Arsenic : It should be no more than 4.0 ppm tested by Arsenic Limit Test.

(4) Lead : When 5.0 g of Gallic Acid is tested by Atomic Absorption Spectrophotometry or Inductively Coupled Plasma Emission Spectroscopy, its content should not be more than 2.0 ppm.

Loss on Drying When Gallic Acid is dried for 2 hours at 105°C, the weight loss should not be more than 10%.

Residue on Ignition

Residue on Ignition of Gallic Acid should not be more than 0.1%.

Garden Balsam Extract

Definition Garden Balsam Extract is obtained by extracting root cortex of garden balsam (*Impatiens balsamina* LINNE) of Balsaminaceae with hydrated ethyl alcohol at room temperature. Its major component is quercetin.

Compositional Specifications of Garden Balsam Extract

Content Garden Balsam Extract should contain more than the indicated amount of quercetin ($C_{15}H_{10}O_7$).

Description Garden Balsam Extract is yellowish brown liquid with characteristic scent and slightly bitter taste.

Identification 5 mg of Garden Balsam Extract dissolve in 10 mL of 50% alcohol (Test Solution). Separately, 5 mg of quercetin standard dissolve in 10 mL of 50% alcohol (Standard Solution). Spot aliquots 2 μ l of each solution to a thin layer plate by using silica gel (with phosphor) for thin layer chromatography. Using a mixture of n-butyl alcohol : water : acetic acid (7 : 2 : 1) as a developing solvent, each plate is developed and dried in air. When these plates are observed under UV light, the spot for Test Solution should have the same color tone and position as the spot for Standard Solution.

Purity (1) Arsenic : It should be no more than 4.0 ppm tested by Arsenic Limit Test.

(2) Lead : When 5.0 g of Garden Balsam Extract is tested by Atomic Absorption Spectrophotometry or Inductively Coupled Plasma Emission Spectroscopy, its content should not be more than 2.0 ppm.

Residue on Ignition when Residue on Ignition analysis is done with accurately weighted 1 g of Garden Balsam Extract, the amount of Residue on Ignition should not be more than 1.0%.

Assay Approximately 0.4 g of Garden Balsam Extract is precisely weighted and dissolved in methyl alcohol (total volume = 50 mL), which is filtered through a 0.5 μ m Millipore filter (Test Solution). Separately, 50 mg of quercetin standard is precisely weighted and dissolved in methyl alcohol (total volume = 50 mL), which is filtered through a 0.5 μ m Millipore filter (Standard Solution). 10 μ l each of Test and Standard Solutions is injected into a high-performance liquid chromatography under the following Operation Conditions. The content of quercetin is obtained by the following equation.

$$\text{Content(\%)} = \frac{\text{Weight of the standard(mg)}}{\text{weight of the sample(mg)}} \times \frac{\text{peak area of test solution}}{\text{peak area of standard solution}} \times 100$$

Operation Conditions

-Detector : UV 375 nm

-Column : μ -Bondapak C_{18} (3.9 mm \times 300 mm) or its equivalent

-Column Temperature : room temperature

-Mobile Phase : methyl alcohol : water : acetic acid (15:3:1)

-Flow Rate : 1.0 mL/min

Gardenia Blue

INS No.: 165

Definition Gardenia Blue is a pigment obtained by enzyme treating (with β -glucosidase, an enzyme used for food) on a mixture of hydrolyzed matter and decomposed protein from iridoid glycoside contained in fruit extract of gardeniae (*Gardenia augusta* Merrill or *Gardenia jasminoides* Ellis) of rubiaceae. Dilutant, stabilizer, or solvent can be added for the purpose of color value adjustment and quality preservation.

Compositional Specifications of Gardenia Blue

Content Color value ($E_{1cm}^{10\%}$) of Gardenia Blue should be higher than the indicated value.

Description Gardenia Blue is deep blue liquid, lump, powder, or paste having a slight characteristic odor.

Identification (1) Test Solution obtained in Color Value section shows blue color and a absorption maximum at about 595 nm.

(2) The colour of test solution is blue. When Test Solution in (1) is alkalinized with a few drops of 1N sodium hydroxide solution, its color almost doesn't change.

(3) When Test Solution in (1) is acidified with a few drops of 1N hydrochloric acid, where 1 ~ 3 drops of sodium hypochlorite (effective chlorine should not be less than 4%), the solution decolorizes rapidly.

Purity (1) Arsenic : It should be no more than 4.0 ppm tested by Arsenic Limit Test.

(2) Lead : When 5.0 g of Gardenia Blue is tested by Atomic Absorption Spectrophotometry or Inductively Coupled Plasma Emission Spectroscopy, its content should not be more than 10.0 ppm.

(3) Residual Solvent : When Gardenia Blue is tested by Purity (5) for 「Paprika Extract Pigments」, residual methanol should not be more than 0.1% (based on the product whose color value is 40).

Assay (Color Value)

Appropriate amount of Gardenia Blue is precisely weighed so that the absorbance is within 0.3 ~ 0.7 and dissolved in citric acid dibasic sodium phosphate buffer solution with pH 6.0 so that the total volume is 100 mL. 1 mL of this solution is diluted to 100 mL with citric acid dibasic sodium phosphate buffer solution with pH 6.0 (Test Solution). If necessary, the solution is centrifuged and the supernatant is used. Using citric acid-dibasic sodium phosphate buffer solution with pH 6.0 as a reference solution, absorbance A is measured at 595 nm with 1 cm cell. Color value is obtained using the following equation.

$$\text{Color value } (E_{1cm}^{10\%}) = \frac{A \times 1,000}{\text{weight of the sample(g)}}$$

◦ Citric acid-dibasic sodium phosphate buffer solution (pH 6.0)

Solution 1 : 0.1 M citric acid solution : 1 L of solution containing 21.01 g of citric acid ($C_6H_8O_7 \cdot H_2O$).

Solution 2 : 0.2 M dibasic sodium phosphate solution : 1 L of solution containing 71.63 g of dibasic sodium

phosphate ($\text{Na}_2\text{HPO}_4 \cdot 12\text{H}_2\text{O}$).

Solution 1 and Solution 2 are mixed well (73.7:126.3) and its pH is adjusted to 6.0.

Gardenia Red

Definition Gardenia Red is a pigment obtained by enzyme treating (with β -glucosidase, an enzyme used for food) on a mixture of hydrolyzed matter and decomposed protein from iridoid glycoside contained in fruit extract of gardeniae (*Gardenia augusta* Merrill or *Gardenia jasminoides* Ellis) of rubiaceae. Dilutant, stabilizer, or solvent can be added for the purpose of color value adjustment and quality preservation.

Compositional Specifications of Gardenia Red

Content Color value ($E_{1cm}^{10\%}$) of Gardenia Red should be higher than the indicated value.

Description Gardenia Red is dark reddish violet liquid, lump, powder or paste having a slight characteristic odor.

Identification (1) Test Solution obtained in Color Value section shows reddish violet color and a absorbance maximum at about 535 nm.

(2) When pH of Test Solution in (1) is adjusted to 2.5 or less with dilute hydrochloric acid, its color almost doesn't change.

(3) When pH of Test Solution in (1) is adjusted to 2.0 or less with dilute hydrochloric acid, where 3 drops of sodium hypochlorite (effective chlorine should not be less than 4%), the solution decolorizes rapidly but doesn't form precipitates.

Purity (1) Arsenic : It should be no more than 4.0 ppm tested by Arsenic Limit Test.

(2) Lead : When 5.0 g of Gardenia Red is tested by Atomic Absorption Spectrophotometry or Inductively Coupled Plasma Emission Spectroscopy, its content should not be more than 8.0 ppm.

Assay (Color Value) Appropriate amount of Gardenia Red is precisely weighed so that the absorbance is within 0.3 ~ 0.7 and dissolved in citric acid-dibasic sodium phosphate buffer solution with pH 4.0 so that the total volume is 100 mL. 1 mL of this solution is diluted to 100 mL with citric acid-dibasic sodium phosphate buffer solution with pH of 4.0 (Test Solution). If necessary, the solution is centrifuged and the supernatant is used. Using citric acid-dibasic sodium phosphate buffer solution with pH 4.0 as a reference solution, absorbance A is measured at 535 nm wavelength with 1cm cell. Color value is obtained using the following equation.

$$\text{Color Value}(\overset{10\%}{E}_{1cm}) = \frac{A \times 1,000}{\text{weight of the sample(g)}}$$

◦ Citric acid-dibasic sodium phosphate buffer solution (pH 4.0)

Solution 1 : 0.1M citric acid solution : 1ℓ of solution containing 21.01 g of citric acid ($C_6H_8O_7 \cdot H_2O$).

Solution 2 : 0.2M dibasic sodium phosphate solution : 1ℓ of solution containing 71.63 g of dibasic sodium phosphate ($Na_2HPO_4 \cdot 12H_2O$).

Solution 1 and Solution 2 are mixed well (123:77) and its pH is adjusted to 4.0.

Gardenia Yellow

INS No.: 164

Definition Gardenia Yellow is a pigment obtained by extracting and hydrolyzing fruit of gardeniae (*Gardenia augusta* Merrill or *Gardenia jasminoides* Ellis) of rubiaceae. Major pigments are crocin and crocetin of carotinoids. Dilutant, stabilizer, or solvent can be added for the purpose of color value adjustment and quality preservation.

Compositional Specifications of Gardenia Yellow

Content Color value ($E_{1cm}^{10\%}$) of Gardenia Yellow should be higher than the indicated value.

Description Gardenia Yellow is yellow ~ orange yellowish red liquid, lump, powder or paste having a slight characteristic odor.

Identification (1) Test Solution obtained in Color Value section shows yellow color and a absorption maximum at about 440 nm or 420 nm.

(2) When 5 mL of sulfuric acid is added to 0.5 g of Gardenia Yellow (if necessary, evaporated to dryness by heating in a water bath and then cooled prior to use), it shows blue color, which changes to violet and then brown.

Purity (1) Arsenic : It should be no more than 4.0 ppm tested by Arsenic Limit Test.

(2) Lead : When 5.0 g of Gardenia Yellow is tested by Atomic Absorption Spectrophotometry or Inductively Coupled Plasma Emission Spectroscopy, its content should not be more than 10.0 ppm.

Assay (Color Value) Appropriate amount of Gardenia Yellow is precisely weighed so that the absorbance is within 0.3 ~ 0.7 and dissolved in 50 v/v% alcohol (total volume 100 mL). 1 mL of this solution is diluted to 100 mL with 50 v/v% alcohol (Test Solution). If necessary, the solution is centrifuged and the supernatant is used. Using 50v/v% alcohol as a blank solution, absorbance A is measured at the absorption maximum at about 440 nm or 420 nm with 1cm cell. Color value is obtained using the following equation.

$$\text{Color value } (E_{1cm}^{10\%}) = \frac{A \times 1,000}{\text{weight of the sample(g)}}$$

Gelatin

INS No.: 428

Synonyms: Edible gelatin

CAS No.: 9000-70-8

Definition Gelatin is the product obtained from partial hydrolysis of collagen, the chief protein component of the bones and skins of animal. If it is prepared by treating collagen with acid processing, isoelectric point exhibited pH 7.0~9.0. If it is prepared by treating collagen with alkali processing, isoelectric point exhibited pH 4.6~5.2. If it is a mixture treated by both acid and alkali as well as Gelatin is produced by modification of the above mentioned process may exhibit isoelectric points outside of the stated ranges.

Compositional Specifications of Gelatin

Description Gelatin is pale yellow~brown plate, piece, or rough or fine powder.

Identification (1) When chromium trioxide solution or picric acid solution is added to 5 mL of aqueous solution (1→100) of Gelatin, precipitates are formed.

(2) When tannic acid solution is added to 5 mL of aqueous solution (1→5,000) of Gelatin, it becomes turbid.

Purity (1) Other odor and Insoluble substances : A hot solution (1→40) of Gelatin should not generate unpleasant odor. The 2 cm liquid layer of this solution should be colorless and transparent. Even if it is turbid, it should not be deeper than the color of 50 mL of solution that is prepared by mixing 0.3 mL hydrochloric acid and 1 mL nitric acid adding 1 mL of 0.1 N silver nitrate solution and water, and allow to stand for 5 minutes.

(2) Sulfites : 20 g of Gelatin is dissolved in 150 mL of boiling water in a round bottom flask. 5 mL of phosphoric acid and 1 g of sodium bicarbonate are added and a condenser is attached. 50 mL of 0.1 N iodine solution is added to a collecting container. The end of the condenser is immersed in the iodine solution. It is then distilled and approximately 50 mL of distillate is collected. The distillate is acidified with 2 ~ 3 drops of hydrochloric acid. 2 mL of barium chloride solution is added to the distillate, which is then heated until it becomes colorless. The precipitates of barium sulfate are filtered and washed with water. After heat treatment, the remaining residue should not be more than 3 mg. Separately, a blank test is carried out by the same procedure.

(3) Arsenic : It should be no more than 1.0 ppm tested by Arsenic Limit Test.

(4) Chromium : 5 g of gelatin is placed in decomposition flask. 50 mL of water and 10 mL of nitric acid are added and mixed to the flask and the solution in the flask is allowed to stand. The solution is mildly heated and it is cooled after stopping vigorous reaction. Then, 5 mL of sulfuric acid is added to the solution and the solution is mildly heated again. Add 2 ~ 3 mL of nitric acid to it when the

content of the solution appears dark brown color. Heat continually it until the content of the solution appear light yellow ~ colorless, which means to finish the decomposition of the solution. After cooling the decomposition solution, add water to the solution and make up 50 mL as a test solution. Make blank test solution to the same procedure. Separately, take 20 mL of chrome standard stock solution(1000 ppm) and make up to 200 mL with 0.2 % of nitric acid solution. Then take again 20 mL in this solution and make up to 200 mL with 0.2 % of nitric acid solution. The concentration of this diluted solution is 10 $\mu\text{g}/\text{mL}$ (10 ppm). Take each of 1 mL and 5 mL from the diluted solution and each taken solution is made up to 10 mL with 0.2 % of nitric acid solution(1, 5, 10ppm). The amount of test solution and each of standard solution should not be more than 10 ppm when testing according to the saltless process of automatic absorption spectrophotometry.

- (5) Lead : When 5.0 g of Gelatin is tested by Atomic Absorption Spectrophotometry or Inductively Coupled Plasma Emission Spectroscopy, its content should not be more than 1.5 ppm.
- (6) Total Viable Aerobic Count : When Gelatin is tested by Microbe Test Methods for Total Viable Aerobic Count (Number of General Germs) in General Test Method in 「Standards and Specifications for Foods」, it should not be more than 1,000 colonies per 1 g
- (7) Salmonella : Gelatin is tested by Microbe Test Methods for Salmonella in General Test Methods in 「Standards and Specifications for Foods」. It should be negative (-).
- (8) E. Coli : When Gelatin is tested by Microbe Test Methods for E. Coli in General Test Method 「Standards and Specifications for Foods」 it should be negative (-).

Residue on Ignition When Residue on Ignition analysis is done with 1 g of Gelatin, the amount of residue should not be more than 2%.

Gellan Gum

INS No.: 418

CAS No.: 71010-52-1

Definition Gellan Gum is a high molecular weight polysaccharide gum produced by pure culture and fermentation of a carbohydrates by *Pseudomonas elodea*, purified by recovery with isopropyl alcohol, dried, and milled. Heteropolysaccharide is principally composed of rhamnose, gluconic acid, and glucose (1:1:2). It can also contain acyl (glyceryl and acetyl) group as an O-glycosidically linked ester.

Compositional Specifications of Gellan Gum

Content Gellan Gum (on a dried basis) contains 3.3~6.8% of carbon dioxide (CO₂).

Description Gellan Gum is off-white powder.

Identification (1) 1 g of Gellan Gum is hydrated with 99 mL of water (1% solution). It is stirred for about 2 hours using a magnetic stirrer. Small amount of supernatant is drawn into a wide mouth pipette and transferred into a 10% calcium chloride solution. A tough worm-like gel will be formed immediately.

(2) 0.5 g of sodium chloride is added to 1% solution obtained in (1), which is heated to 80°C with stirring, and hold at 80°C for 1 minute. The solution is allowed to cool to room temperature. A firm gel is formed.

Purity (1) Arsenic : It should be no more than 4.0 ppm tested by Arsenic Limit Test.

(2) Lead : When 5.0 g of Gellan Gum is tested by Atomic Absorption Spectrophotometry or Inductively Coupled Plasma Emission Spectroscopy, its content should not be more than 2.0 ppm.

(3) Cadmium : When 5.0 g of Gellan Gum is tested by Atomic Absorption Spectrophotometry or Inductively Coupled Plasma Emission Spectroscopy, its content should not be more than 1.0 ppm.

(4) Mercury : When 0.1 g of Gellan Gum is tested by Mercury Test Method, its content should not be more than 1.0ppm.

(5) Isopropyl alcohol : 5 g of Gellan Gum is precisely weighed into a 1,000 mL single neck round bottom distilling flask with 24/40 ground joint, where 1 mL of anti foaming agent (Dow-Corning G 10 or its equivalent) and 200 mL of water are added. It is then stirred for 1 hour. A 400 mL reflux condenser, distilling head, and a collector are attached. Approximately 95 mL of distillate is collected (care must be taken so that bubbles does not enter into the collector. 4 mL of internal standard solution is added to the collected distillate, where water is added to bring the total volume to 100 mL, test solution. Test Solution and mixed standard solution are analyzed with gas chromatography and the amount of isopropyl alcohol is obtained by the following equation. The content should not be more than 750ppm. The response factor (f) is calculated by the area ratio(A_{IPA}/A_{TDA}) between peak areas of isopropyl alcohol and tert-butyl alcohol in the mixed standard solution.

$$\text{Content of isopropyl alcohol(ppm)} = \frac{A_{\text{IPA}} \times 4,000}{f \times A_{\text{TBA}} \times \text{weight of the sample(g)}}$$

aIPA : peak area of isopropyl alcohol in Test Solution

aTBA : peak area of tert-butyl alcohol in Test Solution

Operation Conditions

- Column : A stainless steel tube 3.2mm x 1.8m
- Column Filler : 80 ~ 100 Porapak QS (or its equivalent)
- Detector : (Hydrogen) Flame Ionization Detector (FID)
- Injection port temperature : 200°C
- Column Temperature : 165°C
- Detector Temperature : 200°C
- Carrier gas and flow rate : Nitrogen, Flow rate is controlled so that the retention time of isopropyl alcohol and tert-butyl alcohol is about 2 minutes and 3 minutes, respectively.

Solutions

- Mixed Standard Solution : 4 mL each of IPA standard solution and TBA standard solution is pipetted into a flask, and diluted to 100 mL with water. 1 mL of this solution contains approximately 40 µg each of isopropyl alcohol and tert-butyl alcohol per mL.
- IPA Standard Solution : Approximately 500 mg of isopropyl alcohol (chromatographic quality) is precisely weighed and diluted to 50 mL with water. 10 mL of this solution is further diluted to 100 mL with water.
- TBA Standard Solution : Approximately 500 mg of tert-butyl alcohol (chromatographic quality) is precisely weighed and diluted to 50 mL with water. 10 mL of this solution is further diluted to 100 mL with water.

(6) Nitrogen : When Gellan Gum is tested by Kjeldahl Nitrogen Test in nitrogen determination method, the amount should be not more than 3.0%.

(7) Total Viable Aerobic Count : When Gellan Gum is tested by Microbe Test Methods for Total Viable Aerobic Count (Number of General Germs) in General Test Method in 「Standards and Specifications for Foods」, it should not be more than 10,000 cfu per 1 g

(8) E. Coli : When Gellan Gum is tested by Microbe Test Methods for E. Coli in General Test Method 「Standards and Specifications for Foods」, it should be negative (-).

(9) Salmonella : When Gellan Gum is tested by Microbe Test Methods for Salmonella in General Test Method 「Standards and Specifications for Foods」, it should be negative (-).

(10) Number of Fungi : When Gellan Gum is tested by Microbe Test Methods for Number of Fungi in General Test Method in 「Standards and Specifications for Foods」, it should not be more than 400

cfu per 1 g

Loss on Drying When Gellan Gum is dried for 2 hours and 30 minutes at 105°C, the weight loss should not be more than 15%.

Ash 3 g of Gellan Gum is precisely weighed and dried for 4 hours at 105°C. It is then reduced ash at 650°C until the carbon is completely removed. The amount of remaining ash should not be more than 4 ~ 12%.

Assay Approximately 1.2 g of Gellan Gum is precisely weighed and analyzed by Assay of 「Xantan Gum」.

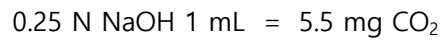

Geraniol



Chemical Formula: $C_{10}H_{18}O$

Molecular Weight: 154.25

Synonyms: 2,6-Dimethyl-2,6-octadien-8-ol

CAS No.: 106-24-1

Compositional Specifications of Geraniol

Content Geraniol should contain not less than 88.0% of geraniol ($C_{10}H_{18}O$).

Description Geraniol is a colorless to light yellow, transparent liquid having a characteristic odor.

Identification To 1 mL of Geraniol, add 1 mL of acetic acid, anhydrous and 1 drop of phosphoric acid, keep at a slightly warm temperature for 10 minutes, add 1 mL of water, shake in hot water for 5 minutes, cool, and make slightly alkaline with anhydrous sodium carbonate solution. An odor of geranyl acetate is evolved.

Purity (1) Specific Gravity : Specific gravity of Geraniol should be within a range of 0.870 ~ 0.885

(2) Refractive Index : Refractive Index n_D^{20} of Geraniol should be within a range of 1.469 ~ 1.478.

(3) Clarity and Color of Solution : When 1 mL of the solution is dissolved in 3 mL of 70% ethanol, the solution should be clear.

(4) Acid Value : Acid value of Geraniol is tested by Acid Value in Flavoring Substance Test. It should not be more than 1.

(5) Ester Value : Accurately weigh about 5 g Geraniol is tested by Ester Value and in Flavoring Substance Test. It should not be more than 3.

(6) Aldehyde : Accurately weigh about 5 g of Geraniol, and proceed as directed under Method 2 in aldehyde and ketone content in Flavoring Substances Tests. In the procedure, allow the mixture to stand for 15 minutes before titrating. The volume of consumed 0.5 N hydrochloric acid is not more than 0.65 mL.

Assay Proceed as directed under Method 1 in alcohol content in Flavoring Substances Tests, using 1 g of acetylated oil.

Geranyl Acetate



Chemical Formula: $C_{12}H_{20}O_2$

Molecular Weight: 196.29

Synonyms: Geraniol acetate

CAS No.: 105-87-3

Compositional Specifications of Geranyl Acetate

Content Geranyl Acetate should contain not less than 90.0% of geranyl acetate ($C_{12}H_{20}O_2$).

Description Geranyl Acetate is a colorless to light yellow, transparent liquid with a characteristic odor.

Identification To 1 mL of Geranyl Acetate, add 5 mL of 10% alcoholic solution of potassium solution, and heat in a water bath. The characteristic odor disappears, and an odor of geraniol is evolved. Cool, and add 2 mL of diluted hydrochloric acid and 2 mL of water. The solution responds to the test for Acetate (C) in Identification.

Purity (1) Specific Gravity : Specific gravity of Geranyl Acetate should be within a range of 0.900 ~ 0.914

(2) Refractive Index : Refractive Index n_D^{20} of Geranyl Acetate should be within a range of 1.458 ~ 1.464

(3) Clarity and Color of Solution : When 1 mL of Geranyl Acetate is dissolved in 8 mL of 70% alcohol, the solution should be clear.

(4) Acid Value : Acid value of Geranyl Acetate is tested by Acid Value in Flavoring Substance Test. The content should not be more than 1.

Assay Accurately weigh about 1 g of Geranyl Acetate, and proceed as directed under Ester Value and Ester Content in Flavoring Substances Tests.

1 mL of 0.5 N alcoholic solution of potassium hydroxide = 98.15 mg of $C_{12}H_{20}O_2$

Geranyl Formate



Chemical Formula: $C_{11}H_{18}O_2$

Molecular Weight: 182.26

Synonyms: Geranyl methanoate

CAS No.: 105-86-2

Compositional Specifications of Geranyl Formate

Content Geranyl Formate should contain not less than 85.0% of Geranyl Formate ($C_{11}H_{18}O_2$).

Description Geranyl Formate is a colorless or slightly yellowish, transparent liquid having a characteristic odor.

Identification (1) To 1 mL of Geranyl Formate, add 10 mL of 10% alcoholic solution of potassium hydroxide, and heat in a water bath for 5 minutes while shaking. The characteristic odor disappears, and an odor of geraniol is evolved.

(2) To 1 mL of Geranyl Formate, add 10 mL of sodium hydroxide solution, heat in a water bath for 5 minutes while shaking, and allow to stand. To 1 mL of the solution of the lower layer, add 1.5 mL of diluted hydrochloric acid, and add 20 mg of magnesium dust divided into several portions. After effervescence ceases, add 3 mL of diluted sulfuric acid (3→5) and 10 mg of chromotropic acid, shake and warm in a hot water for 10 minutes. A pink-purple color develops.

Purity (1) Specific Gravity : Specific gravity of Geranyl Formate should be within a range of 0.906 ~ 0.920

(2) Refractive Index : Refractive Index n_D^{20} of Geranyl Formate should be within a range of 1.457 ~ 1.466

(3) Clarity and Color of Solution : When 1 mL of Geranyl Formate is dissolved in 3 mL of 80% ethanol, the solution should be clear.

(4) Acid Value : Acid value of Geranyl Formate is tested by Acid Value in Flavoring Substance Test. It should not be more than 3. In this case, titrate while cooling in ice water, and continue the titration until a light pink color persists for 10 seconds.

Assay Accurately weigh about 1 g of Geranyl Formate, and test Saponification Value by saponification value measuring method in Flavoring Substances Tests and Acid Value by Purity (4). Calculate the content by the following formula:

$$\text{Content(\%)} = \frac{\text{Saponification value} - \text{Acid value}}{561.1} \times 182.26$$

Gibberellic Acid

Chemical Formula: C₁₉H₂₂O₆

Molecular Weight: 346.37

CAS No.: 77-06-5

Definition *Gibberella fujikuroi* is cultured, which is then filtered. The filtrate is concentrated under a reduced pressure. The concentrate is extracted and crystallized. Gibberellic Acid is obtained by purifying the crystallized precipitates.

Compositional Specifications of Gibberellic Acid

Content Gibberellic Acid should contain not less than 90.0% of gibberellic acid (C₁₉H₂₂O₆ = 346.37).

Description Gibberellic Acid is odorless white ~ pale yellow crystalline powder.

Identification A solution that dissolved in 2 mL of sulfuric acid a few milligrams of Gibberellic Acid is red color with green fluorescence.

Purity (1) Specific Rotation : Approximately 5 g of Gibberellic Acid is precisely weighed and dissolved in alcohol to make 50 mL. (This solution should not be heated during preparation.) The polarity of this solution should be $[\alpha]_D^{20} = +75.0 \sim +90.0^\circ$

(2) Arsenic : It should be no more than 4.0 ppm tested by Arsenic Limit Test.

(3) Lead : When 5.0 g of Gibberellic Acid is tested by Atomic Absorption Spectrophotometry or Inductively Coupled Plasma Emission Spectroscopy, its content should not be more than 5.0 ppm.

Loss on Drying When Gibberellic Acid is dried at 100°C for 7 hours in vacuum of 20 mmHg, the weight loss should not be more than 3%.

Assay Approximately 40 mg is precisely weighed and dissolved in methyl alcohol (total volume = 50 mL). 10 mL of this solution is diluted to 100 mL with methyl alcohol (Test Solution). Separately, 25 mg of gibberellic acid standard is precisely weighed and dissolved in methyl alcohol (total volume = 50 mL). 10 mL of this solution is diluted to 50 mL with methyl alcohol (Standard Solution). Each of 5 mL Test Solution, 4 mL and 5 mL portions of the Standard Solution is separately added into 3 test tubes. The test tubes are evaporated to dryness and further dried at 90°C for 10 minutes. The tubes are allowed to cool to room temperature. The residue in each test tube is dissolved in 10 mL each of diluted sulfuric acid (8→10), which is then heated for 10 minutes in a water bath and cooled for 5 minutes in 10°C water bath. Absorbance of each solution is determined at 535 nm with 1 cm cells using dilute sulfuric acid as the blank. The content is measured using the following equation (Note the absorbance of the two solutions prepared from the 4 mL and 5 mL aliquots of the Standard Solution and use the nearest one to the solution prepared with the Sample solution, for the calculation).

$$\text{Content(\%)} = 500 \times C \times \frac{V}{5} \times \frac{A_u}{A_s} \times \frac{100}{\text{weight of the sample(mg)}}$$

C : Concentration of the Standard Solution (mg/mL)

V : Amount of Standard Solution used

A_u : Absorbance of the Sample Solution

A_s : Absorbance of Standard Solution used

Potassium Aluminium Silicate-Based Pearlescent Pigments

Synonyms: Mica-based pearlescent pigments

INS No.: 176(i), 176(ii), 176(iii)

Definition It has type 1, type 2 and type 3. Definitions of each type are as follows.

Type 1 of Potassium Aluminium Silicate-Based Pearlescent Pigments: It is manufactured by calcinating at high temperature after a pigmentating titanium dioxide to potassium aluminium silicate or mica. It is composed of potassium aluminium silicate or mica that are coated with titanium dioxide, and it is a colour that has pearly white. The pearly white varies depending on the size of the particles and the thickness of titanium dioxide applied to the potassium aluminium silicate or mica. There shall be no particles less than 100 nm, and average particle size is generally between 3~82 μm .

Type 2 of Potassium Aluminium Silicate-Based Pearlescent Pigments : It is manufactured by calcinating at high temperature after a pigmentating iron oxide to potassium aluminium silicate or mica. It is composed of potassium aluminium silicate or mica that are coated with iron oxide, and it is a colour that has pearly white. The pearly white varies depending on the size of the particles and the thickness of iron oxide applied to the potassium aluminium silicate or mica. There shall be no particles less than 100 nm, and average particle size is generally between 18~25 μm .

Type 3 of Potassium Aluminium Silicate-Based Pearlescent Pigments : It is manufactured by calcinating at high temperature after a pigmentating both titanium dioxide and iron oxide to potassium aluminium silicate or mica. It is composed of potassium aluminium silicate or mica that are coated with both titanium dioxide and iron oxide, and it is a colour that has pearly white. The pearly white varies depending on the size of the particles and the thickness of both titanium dioxide and iron oxide applied to the potassium aluminium silicate or mica. There shall be no particles less than 100 nm, and average particle size is generally between 7~25 μm .

Content Specifications of Potassium Aluminium Silicate-Based Pearlescent Pigments

Content Type 1 has 10~61% of titanium oxide and 39~90% of potassium aluminium silicate or mica. Type 2 has 32~55% of iron oxide and 45~68% of potassium aluminium silicate or mica. Type 3 has 33~52% of titanium oxide, 2~12% of iron oxide and 36~65% of potassium aluminium silicate or mica.

Description Potassium Aluminium Silicate-Based Pearlescent Pigments is pearly white powder.

Identification (1) Solubility : It is not soluble in water.

(2) Titanium shall be identified in type 1, iron shall be identified in type 2, and both titanium and iron shall be identified in type 3, when tested by Atomic Absorption Spectrophotometry or Inductively Coupled Plasma Emission Spectroscopy.

Purity Impurities dissolved in 0.5N hydrochloric acid : weigh approximate 20 g of this additive precisely and put it into 250 mL flask. Add 100 mL of 0.5N hydrochloric acid. After attaching a reflux cooler,

heat it for 30 minutes. After colling the soltion, filter it with a 0.1µm membrane filter, and wash the residues on the filter with a hot 0.5N hydrochloric acid twice. Then add it with the rest. Add 0.5 hydrochloric acid to it and make it to 200 mL as a test solution. Mercury is tested by the Mercury test method, and Arsenic, lead, cadmium, antimony, barium, chromoium, cooper, nickel and zinc are tested by the inductive coupling plasma luminous intensity method.

Arsenic : It should be no more than 3.0 ppm.

Lead : It should be no more than 4.0 ppm.

Cadmium : It should be no more than 1.0 ppm.

Mercury : It should be no more than 1.0 ppm.

Antimony : It should be no more than 3.0 ppm.

Barium : It should be no more than 25.0 ppm.

Chromoium : It should be no more than 100.0 ppm.

Cooper : It should be no more than 25.0 ppm.

Nickel : It should be no more than 50.0 ppm.

Zinc : It should be no more than 25.0 ppm.

Loss on Drying When Potassium Aluminium Silicate-Based Pearlescent Pigments is dried for 2 hours at 105°C, the weight loss should not be more than 0.5 %.

Assay Weigh approximate 0.5 g of this additive precisely, and put it in a platinum or nickel crucible. Add 5 g of potassium hydroxide and 2 g of boric acid. And completely dissolve it using a torch burner and cool it to room temperature. Move to 250 mL PTFE beaker, add 150 mL of hot distilled water and stir to dissolve. wash crucible with a small amount of hot water and put the rest into the beaker. Add 50 mL of hydrochloric acid. After moving it to the 250 mL mass flask, wash the beaker three times with hot water and move the rest to the mass flask and make it as 250 mL. Dilute it with 2% hydrochloric acid solution and use it as test solution. inject the test solution into an inductive coupling plasma photometer and apply titanium line wavelength (334.94nm), iron line wavelength (259.940nm) and aluminum line wavelength (396.152nm). Each concentration of titanium, iron and aluminum(µg/mL) is calculated from each standard curve. Calculate the content(%) of iron oxide and mica according to the following formula:

$$\text{the content of titanium dioxide (TiO}_2\text{, \%)} = \frac{1.668 \times C_{\text{Ti}} \times 250 \times \text{DF}}{W \times 10^6} \times 100$$

$$\text{the content of iron oxide (Fe}_2\text{O}_3\text{, \%)} = \frac{1.43 \times C_{\text{Fe}} \times 250 \times \text{DF}}{W \times 10^6} \times 100$$

$$\text{the content of mica(\%)} = \frac{4.92 \times C_{\text{Al}} \times 250 \times \text{DF}}{W \times 10^6} \times 100$$

C_{Ti} : Concentration of titanium in the test solution($\mu\text{g/mL}$)

C_{Fe} : Concentration of iron in the test solution($\mu\text{g/mL}$)

C_{Al} : Concentration of aluminium in the test solution($\mu\text{g/mL}$)

DF : Diluted drainage of the test solution

W : Weight of sample(g)

Glacial Acetic Acid

Chemical Formula: CH₃COOH

Molecular Weight: 60.05

INS No.: 260

Synonyms: Ethanoic acid

CAS No.: 64-19-7

Content Specifications of Glacial Acetic Acid

Content Glacial Acetic Acid should contain not less than 99.0% of acetic acid (C₂H₄O₂).

Description Glacial Acetic Acid is colorless transparent liquid or crystalline lump with characteristic irritating odor.

Identification (1) Glacial Acetic Acid solution (1→3) is strongly acidic.

(2) Glacial Acetic Acid solution (1→3) responds to the test for acetate salts in Identification.

Purity (1) Solidification Temperature : Solidification temperature of Glacial Acetic Acid should not be less than 14.5°C.

(2) Arsenic : It should be no more than 1.3 ppm tested by Arsenic Limit Test.

(3) Lead : When 5.0 g of Glacial Acetic Acid is tested by Atomic Absorption Spectrophotometry or Inductively Coupled Plasma Emission Spectroscopy, its content should not be more than 0.5 ppm.

(4) Mercury : When Glacial Acetic Acid is tested by Mercury Limit Test, its content should not be more than 1.0 ppm.

(5) Readily Oxidized Matters : 2 g of Glacial Acetic Acid is dissolved in 10 mL of water, where 0.1 mL of 0.1 N potassium permanganate solution is added. The color of the solution should not disappear within 30 minutes

(6) Residue on Evaporation : 10 g of Glacial Acetic Acid is evaporated and then dried for 2 hours at 100°C. The residue should not be more than 1 mg.

Assay Accurately weigh about 1 g of Glacial Acetic Acid and dissolve in 40 mL of water, which is titrated with 1 N sodium hydroxide solution (indicator : 2 drops of phenolphthalein solution).

1 mL of 1 N sodium hydroxide solution = 60.05 mg C₂H₄O₂

β-Glucanase

Definition β-Glucanase is an enzyme obtained from the culture of *Aspergillus niger* and its variety, *Bacillus subtilis* and its variety, *Humicola insolens* and its variety, and *Trichoderma reesei*, *Talaromyces emersonii* and its variety. Dilutant or stabilizer can be added for the purpose of activity adjustment and quality preservation.

Compositional Specifications of β-Glucanase

Description β-Glucanase is white to dark brown powder, particles, pastes or colorless to dark brown liquid.

Identification When β-Glucanase is proceeded as directed under Activity Test, it should have the activity as β-Glucanase.

Purity (1) Arsenic : It should be no more than 4.0 ppm tested by Arsenic Limit Test.

(2) Lead : When 5.0 g of β-Glucanase is tested by Atomic Absorption Spectrophotometry or Inductively Coupled Plasma Emission Spectroscopy, its content should not be more than 5.0 ppm.

(3) Coliform Group : When β-Glucanase is proceeded as directed under Microbe Test Methods for Coliform Group in General Test Methods in 「Standards and Specifications for Foods」, it should contain not more than 30 colonies per 1 g of this product.

(4) Salmonella : When β-Glucanase is proceeded as directed under Microbe Test Methods for Salmonella in General Test Methods in 「Standards and Specifications for Foods」, it should be negative(-).

(5) E. Coli : When β-Glucanase is tested by Microbe Test Methods for E. Coli in General Test Method 「Standards and Specifications for Foods」it should be negative (-).

Activity Test (Activity)

Analysis Principle : Activity test is based on hydrolysis of Lichenin substrate for 15 minutes at pH 6.5, temperature 40°C. The increase in reducing power due to generated reducing matters is measured by Neocuproine method.

◦Preparation of Test Solution : The final diluted solution is prepared so that it contains 0.01~0.02 β-Glucanase units per 1 mL. Sample is taken into a volumetric flask, dissolved and filled with phosphate buffer solution.

◦Procedure : 2 mL each of substrate solution is added into four 25 mL volumetric flasks, which are then isothermalized in a water bath at 40°C for 10 ~ 15 minutes. 1 mL of phosphate buffer solution are added to test tube 1, 1 mL of glucose standard solution are added to test tube 2 (glucose standard), 4 mL of neocuproine solution A and 1 mL of Test Solution are added to test tube 3 (enzyme blank test), 1 mL of Test Solution added to test tube 4 (enzyme test), and 3 mL of phosphate buffer solution are added to test tube 5 (phosphate buffer solution blank test). Test tubes are isothermalized at 40°C for exactly 15 minutes. 4 mL each of neocuproine solution A is added to test tubes 1, 2, 4, and 5. After adding 4 mL each of neocuproine solution B to all test tubes, a glass stopper is placed on each tube (rubber stopper should not be used). It is then colorized by heating vigorously in a water bath. After cooling to room

temperature, water is added to make the total volume to 25 mL. Using either parafilm or appropriate stopper, the content of each tube is mixed well by turning upside down a few times. Using phosphate buffer solution for blank test of test tube 5 as a reference solution, absorbance of each solution is measured at 450 nm with 1cm path length. Enzyme activity is obtained from the following equation.

$$\text{BGU} = \frac{(A_4 - A_3) \times 36 \times 10^6 \times F}{(A_2 - A_1) \times 180 \times 15 \times S}$$

A4 : Absorbance of enzyme test solution (test tube 4)

A3 : Absorbance of enzyme blank test solution (test tube 3)

A2 : Absorbance of glucose standard solution (test tube 2)

A1 : Absorbance of substrate blank test solution (test tube 1)

F : Dilution factor of test solution

S : Weight of sample(μg)

36 : Content of glucose (μg) in glucose standard solution

10^6 : Conversion factor from μg to g

180 : Weight of $1\mu\text{mol}$ of glucose

15 : Reaction time (minutes)

- Definition of Activity : 1 β -Glucanase unit (BGU) corresponds to the amount of enzymes which produce 1 μmol of glucose per 1 minute as reducing sugar, under the test conditions described above.

Solutions

Phosphate Buffer Solution : 13.6 g of potassium phosphate, monobasic is added in 1,900 mL of water. pH is adjusted to 6.5 ± 0.05 with 70% sodium hydroxide solution. The total volume of the solution is make to 2,000 mL with water.

Neocuproine Solution A : 40 g of anhydrous sodium carbonate, 16 g of glycine, and 450 mg of copper sulfate (5 hydrate) are dissolved in approximately 600 mL of water. The total volume is make to 1,000 mL with water.

Neocuproine Solution B : 600 mg of neocuproine hydrochloride is dissolved in 400 mL of water and the total volume is make to 500 mL. If the solution becomes yellow, it is discarded.

Substrate Solution : 150 mg of Lichenin is ground into fine powder using a mortar and pestle, which is dissolved in 50 mL of water at approximately 85°C . When it is dissolved completely (it takes 20 ~ 30 minutes), 90 mg of sodium borohydride is added. It is then heated at boiling point for 1 hour. 15 g of Amberlite MB-20 or equivalent ion exchange resin is added, which is then stirred continuously for 30 minutes. It is vacuum-filtered through Whatman No.1 filter or equivalent using a Buchner funnel, which is then washed with 20 mL of water. 680 mg of potassium phosphate, monobasic is added to the filtrate, which is then filtered through a $0.22\ \mu\text{m}$ Millipore filtration apparatus (or

equivalent). The filtration apparatus is washed with 10 mL of water. pH of the filtrate is adjusted to 6.5 ± 0.05 with 1N sodium hydroxide solution or 1N hydrochloric acid. The total volume is then made to 100 mL with water. The solution should be kept at $2\sim 4^{\circ}\text{C}$ and used within 3 days.

Glucose Standard Solution : 36.0 mg of anhydrous glucose is dissolved in 50 mL of phosphate buffer solution. The total volume is made to 1,000 mL with water.

Storage Standard of β -Glucanase

β -Glucanase should be stored in a hermetic container in a cold dark place.

Glucoamylase

Amyloglucosidase

Definition Glucoamylase is an enzyme obtained from a culture of *Aspergillus niger* and its variety, *Aspergillus oryzae* and its variety, *Rhizopus oryzae* and its variety, and *Aspergillus niger* inserted gene of glucoamylase. Dilutant or stabilizer can be added for the purpose of activity adjustment and quality preservation.

Compositional Specifications of Glucoamylase

Description Glucoamylase. is white to dark brown power, particles, pastes or colorless to dark brown liquid.

Identification When Glucoamylase is proceeded as directed under Activity Test, it should have the activity as glucoamylase

Purity (1) Arsenic : It should be no more than 4.0 ppm tested by Arsenic Limit Test.

(2) Lead : When 5.0 g of Glucoamylase is tested by Atomic Absorption Spectrophotometry or Inductively Coupled Plasma Emission Spectroscopy, its content should not be more than 5.0 ppm.

(3) Coliform Group : Glucoamylase is proceeded as directed under Microbe Test Methods in Coliform Group in General Test Methods in 「Standards and Specifications for Foods」. It should contain not more than 30 colonies per 1 g of this product.

(4) Salmonella : Glucoamylase is proceeded as directed under Microbe Test Methods for Salmonella in General Test Methods in 「Standards and Specifications for Foods」. It should be negative (-).

(5) E. Coli : When Glucoamylase is tested by Microbe Test Methods for E. Coli in General Test Method 「Standards and Specifications for Foods」, it should be negative (-).

Activity Test (activity)

Analysis Principle : Activity test is carried out under a fixed set of conditions at time, temperature, pH, and concentration and is measured as a reducing sugar generated by decomposition of hydrolyzed solution of corn starch.

◦ **Preparation of Test Solution** : Test Method described below is based on the use of sample that contains 0.1 ~ 0.2 units of activity of glucoamylase. This corresponds to an amount that produces 0.2 ~ 0.4 g of reducing sugar under the same test conditions. The most appropriate results can be achieved within this range. Liquid, solid, and liquid extract sample are prepared by the following table, where indicated amounts should be used.

Liquid Sample

Enzyme in sample (unit/mL)	Dilution Factor (mL)	Amount (mL)	Dilution Factor(F)
Not more than 0.05	-	5.0	0.2
0.06 ~ 0.1	-	2.0	0.5

0.11 ~ 0.25	-	0.80	1.25
0.3 ~ 0.5	-	0.40	2.5
0.6 ~ 1.0	-	0.20	5
1.1 ~ 2.0	-	0.10	10
2.1 ~ 4.0	5.0→100	1.00	20
4.1 ~ 5.0	4.0→100	1.00	25
5.1 ~ 7.0	3.0→100	1.00	33.3
7.1 ~ 10.0	2.0→100	1.00	50

Solid Sample and Liquid Extracts

Enzyme in sample (unit/mL)	Weight(g) [※]	Diluted to (mL)	Amount (mL)
Not more than 4	10	1,000	5.0
5 ~ 10	4	1,000	5.0
11 ~ 25	1.6	1,000	5.0
26 ~ 50	1.4	1,000	3.0
51 ~ 75	1.25	1,000	2.0
76 ~ 100	1.00	1,000	2.0
101 ~ 150	1.25	1,000	1.0
151 ~ 200	1.00	1,000	1.0
201 ~ 250	1.50	2,000	1.0
251 ~ 300	1.00	2,000	1.0

※ Sample is accurately weighed and transferred into a 1,000 mL volumetric flask and water is filled up to 2/3. It is then allow to stand for 30 minutes at room temperature, while the flask is vigorously shaken at least 5 times. The flask is then filled with water. The solution is filtered through a Whatman No.12 or equivalent, use the Test Solution. Indicated amount is taken for the test.

Procedure

① Generation of Reducing Sugar : 50 mL of hydrolyzed starch solution and 5 mL of acetate buffer solution are added into a 100 mL volumetric flask, Test Solution. As a reference, water is taken into a volumetric flask and the same procedure is followed. These flasks are allow to stand for 10 minutes in

water bath at 60°C. (Note : For enzymes generated from *Aspergillus oryzae* and *Rhizopus oryzae*, it is carried out at 55°C). Indicated amount of Test Solution is taken into a flask for Test Solution and it is timed simultaneously. (When multiple sample are tested, there can be an interval in sampling time considering the time taken for neutralizing the solution after 120 minute reaction time). The content is mixed completely by shaking and allow to stand for 120 minutes in a water bath. After 115 ~ 118 minutes of reaction time, 3 drops of phenolphthalein TS are added. The flask is removed from water bath when the reaction time reaches exactly 120 minutes. It is then quickly neutralized with 2% sodium hydroxide solution (approximately 3 ~ 7 mL) using a quick drawing burette. It is then cooled to room temperature in running water. The total volume is make to 10 mL with water. 10 mL each of this solution and reference solution is taken and tested for reducing sugar as follows

② Test for Reducing Sugar (Schoorl Method)

(Note : This test method is appropriate for measuring reducing sugar from protein free soluble substances. Sample with considerable amount of proteins are tested after treating with protein precipitating agent.). 10 mL each of Fehling solution A, B is taken into a 250 mL Erlenmeyer flask, where exactly 10 mL of the solution obtained from reducing sugar generation above. A reference solution is treated as same. (Note : When multiple sample are tested, Test Solution is taken into a series of flasks, diluted to 30 mL with water, and Fehling solution A is added. Fehling solution B is added just before heating). The total volume is make to 50 mL with water, which is mixed by gently shaking. Two glass balls are added and a small funnel is placed on top of the flask as a cover. It is then brought to boil within 3 minutes and heated for 2 more minutes. It is then quickly cooled in a ice bath or running water. The funnel is washed with small amount of water. 10 mL of 30% potassium iodide solution and 10 mL of 28% sulfuric acid are added to the solution, which is quickly titrated with 0.1 N sodium thiosulfate solution until the color of iodine disappears. 1 mL of starch TS is added to the resultant solution, which is titrated by drop-wise adding 0.1 N sodium thiosulfate solution until the blue color disappears. The consumed amount (mL) of 0.1N sodium thiosulfate for Test Solution is S, while the consumption for the reference solution is C. Blank test for reagent is carried out twice with 30 mL of water instead of sample. The average amount of consumption mL is B. Using the titrant difference between B and S (in mL), Ts is obtained. (Subtract S from B and indicate the sample in mL consuming 0.1 N Sodium Thiosulfate to obtain the titration difference, taking it as Ts) Using the titrant difference between B and C (in mL), titrant difference of reference is obtained, Tc.

(Note : Refer to the following Table).

Conversion Table for Reducing Sugar Content using titrant difference

Titrant Difference (mL)	Content of reducing sugar (as glucose) (mg)									
	0.0	0.1	0.2	0.3	0.4	0.5	0.6	0.7	0.8	0.9
0.0	0.0	0.3	0.7	1.0	1.3	1.6	1.9	2.2	2.5	2.8
1.0	3.2	3.5	3.8	4.1	4.4	4.7	5.0	5.3	5.6	5.9
2.0	6.4	6.6	6.9	7.2	7.5	7.8	8.1	8.5	8.8	9.1
3.0	9.4	9.8	10.1	10.4	10.7	11.0	11.4	11.7	12.0	12.3
4.0	12.6	13.0	13.3	13.6	14.0	14.3	14.6	15.0	15.3	15.6
5.0	15.9	16.3	16.6	16.9	17.2	17.6	17.9	18.2	18.5	18.9
6.0	19.2	19.5	19.8	20.1	20.5	20.8	21.1	21.4	21.8	22.1
7.0	22.4	22.7	23.0	23.3	23.7	24.0	24.3	24.6	24.9	25.2
8.0	25.6	25.9	26.2	26.6	26.9	27.3	27.6	28.0	28.3	28.6
9.0	28.9	29.3	29.3	30.0	30.3	30.6	31.0	31.3	31.6	31.9
10.0	32.3	32.7	33.0	33.3	33.7	34.0	34.3	34.6	35.0	35.3
11.0	35.7	36.0	36.3	36.7	37.0	37.3	37.6	38.0	38.3	38.7
12.0	39.0	39.3	39.6	40.0	40.3	40.6	41.0	41.3	41.7	42.0
13.0	42.4	42.8	43.1	43.4	43.7	44.1	44.4	44.8	45.2	45.5
14.0	45.8	46.2	46.5	46.9	47.2	47.6	47.3	48.3	48.6	48.9
15.0	49.3	49.6	49.9	50.3	50.7	51.1	51.4	51.7	52.1	52.4
16.0	52.8	53.2	53.2	53.9	54.2	54.5	54.9	55.3	55.6	56.0
17.0	56.3	56.7	57.0	57.3	57.7	58.1	58.4	58.8	59.1	59.5
18.0	59.8	60.1	60.5	60.9	61.2	61.5	61.9	62.3	62.6	63.0
19.0	63.3	63.6	64.0	64.3	64.7	65.0	65.4	65.8	66.1	66.5
20.0	66.9	67.2	67.6	68.0	68.4	68.8	69.1	69.5	69.9	70.3
21.0	70.7	71.7	71.5	71.9	72.2	72.6	73.0	73.4	73.7	74.1
22.0	74.5	74.9	75.3	75.7	76.1	76.5	76.9	77.3	77.7	78.1
23.0	78.5	78.9	79.3	79.7	80.1	80.35	80.9	81.3	81.7	82.1
24.0	82.6	83.0	83.4	83.8	84.2	84.6	85.0	85.4	85.8	86.2

25.0	86.6	87.0	87.4	87.8	88.2	88.6	89.0	89.4	89.8	90.2
26.0	90.7	91.1	91.5	91.9	92.3	92.7	93.1	93.5	93.9	94.3
27.0	94.8									

② Use of this table is based on the assumption that two test results are identical under the same test conditions. The risk of error can be avoided by standardization of careful repetition using known pure glucose (5 samples of 10 ~ 70 mg range). The calibration curve (reducing sugar content mg vs. titrant difference) is a slightly bent straight line. If a standardization curve is adopted, it is not necessary to obtain standardization for the sodium thiosulfate solution. By using 0.065 N sodium thiosulfate solution, titration value for a blank test is increased to 44 ~ 45 mL, thus more accurate result can be obtained.

③ Reducing Sugar Content : By referring to the conversion table (titrant difference to reducing sugar content), reducing sugar content (mg) corresponding to titrant difference (Ts) of sample is obtained, W_s . By the same method, reducing sugar content (mg) corresponding to titrant difference (Ts) of reference is obtained, W_c . The total reducing sugar (glucose) content generated by the Test Solution used is obtained by the following equation.

$$D_s/g = \frac{W_s \times 100}{1,000 \times 10}$$

The total reducing sugar (glucose) content generated by the reference solution is obtained by the following equation.

$$D_c/g = \frac{W_c \times 100}{1,000 \times 10}$$

Calculation of activity of liquid enzyme : Activity of analyzed liquid enzyme is obtained by the following equation.

	F : Dilution factor									
적정 차 (mL)	0.0	0.1	0.2	0.3	0.4	0.5	0.6	0.7	0.8	0.9
환원당량(포도당으로) (mg)										

0.0	0.0	0.3	0.7	1.0	1.3	1.6	1.9	2.2	2.5	2.8
1.0	3.2	3.5	3.8	4.1	4.4	4.7	5.0	5.3	5.6	5.9
2.0	6.4	6.6	6.9	7.2	7.5	7.8	8.1	8.5	8.8	9.1
3.0	9.4	9.8	10.1	10.4	10.7	11.0	11.4	11.7	12.0	12.3
4.0	12.6	13.0	13.3	13.6	14.0	14.3	14.6	15.0	15.3	15.6
5.0	15.9	16.3	16.6	16.9	17.2	17.6	17.9	18.2	18.5	18.9
6.0	19.2	19.5	19.8	20.1	20.5	20.8	21.1	21.4	21.8	22.1
7.0	22.4	22.7	23.0	23.3	23.7	24.0	24.3	24.6	24.9	25.2
8.0	25.6	25.9	26.2	26.6	26.9	27.3	27.6	28.0	28.3	28.6
9.0	28.9	29.3	29.6	30.0	30.3	30.6	31.0	31.3	31.6	31.9
10.0	32.3	32.7	33.0	33.3	33.7	34.0	34.3	34.6	35.0	35.3
11.0	35.7	36.0	36.3	36.7	37.0	37.3	37.6	38.0	38.3	38.7
12.0	39.0	39.3	39.6	40.0	40.3	40.6	41.0	41.3	41.7	42.0
13.0	42.4	42.8	43.1	43.4	43.7	44.1	44.4	44.8	45.2	45.5
14.0	45.8	46.2	46.5	46.9	47.2	47.6	47.3	48.3	48.6	48.9
15.0	49.3	49.6	49.9	50.3	50.7	51.1	51.4	51.7	52.1	52.4
16.0	52.8	53.2	53.5	53.9	54.2	54.5	54.9	55.3	55.6	56.0
17.0	56.3	56.7	57.0	57.3	57.7	58.1	58.4	58.8	59.1	59.5
18.0	59.8	60.1	60.5	60.9	61.2	61.5	61.9	62.3	62.6	63.0
19.0	63.3	63.6	64.0	64.3	64.7	65.0	65.4	65.8	66.1	66.5
20.0	66.9	67.2	67.6	68.0	68.4	68.8	69.1	69.5	69.9	70.3
21.0	70.7	71.1	71.5	71.9	72.2	72.6	73.0	73.4	73.7	74.1
22.0	74.5	74.9	75.3	75.7	76.1	76.5	76.9	77.3	77.7	78.1
23.0	78.5	78.9	79.3	79.7	80.1	80.5	80.9	81.3	81.7	82.1
24.0	82.6	83.0	83.4	83.8	84.2	84.6	85.0	85.4	85.8	86.2
25.0	86.6	87.0	87.4	87.8	88.2	88.6	89.0	89.4	89.8	90.2
26.0	90.7	91.1	91.5	91.9	92.3	92.7	93.1	93.5	93.9	94.3
27.0	94.8									

③ Use of this table is based on the assumption that two test results are identical under the same test conditions. The risk of error can be avoided by standardization of careful repetition using known pure glucose (5 samples of 10 ~ 70 mg range). The calibration curve (reducing sugar content mg vs. titrant difference) is a slightly bent straight line. If a standardization curve is adopted, it is not necessary to obtain standardization for the sodium thiosulfate solution. By using 0.065 N sodium thiosulfate solution, titration value for a blank test is increased to 44 ~ 45 mL, thus more accurate result can be obtained.

$$\text{activity(units/mL)} = \frac{(D_s - D_c) \times F}{c \times 2h}$$

Calculation of activity of solid and liquid extract enzyme : Activity of analyzed solid, liquid extract enzyme is obtained by the following equation.

$$\text{activity(units/g)} = \frac{(D_s - D_c) \times V}{(G \times A \times 2h)}$$

V : Total volume of dilution (mL)

A : Amount of Test Solution used for the test (mL)

(Should refer to the table for Solid sample and Liquid Extracts in Preparation of Test Solution)

G : Weight of sample (g)

Definition of Activity : 1 Glucoamylase unit(GAU) corresponds to the amount of enzyme which produces 1g of glucose as reducing sugar in 1 hour under the test conditions above.

Solutions

Hydrolyzed Starch Solution (4%) : An amount of solidified corn syrup with 15 ~ 20 dextrose equivalent, DE, which corresponds to 40 g of dried form, is dissolved in water and the volume is make to 1,000 mL. This solution is freshly prepared before use.

Acetate Buffer Solution : 60 g of glacial acetic acid is diluted to 1,000 mL with water. pH of this solution is adjusted to 4.2 with sodium acetate solution, which is 136 g of sodium acetate (NaC₂H₃O₂·3H₂O) is dissolved in water and the total volume is make to 1,000 mL with water. (For enzymes produced by *Aspergillus oryzae* and *Rhizopus oryzae*, pH is adjusted to 5.0)

Fehling solution A : 34.66 g of copper sulfite (CuSO₄·5H₂O) is dissolved in water, and the total volume

is make to 500 mL. This solution is stored in a small container with a cap.

Fehling solution B : 173 g of potassium sodium tartrate ($\text{KNaC}_4\text{H}_4\text{O}_6 \cdot 4\text{H}_2\text{O}$) is dissolved in water, where 50 g of sodium hydroxide is added and the total volume is make to 500 mL with water. This solution is stored in a small container with a cap. Same amount of solution A and B are mixed for use. The theoretical titrant consumption for blank test is 27.8 mL, but 27.5 ~ 29.5 mL is appropriate.

Storage Standard of Glucoamylase

Glucoamylase should be stored in a hermetic container in a cold dark place.

Glucomannan

Synonyms: Konjac glucomannan

INS No.: 425

Definition Glucomannan is a polysaccharide (that is purified with isopropyl alcohol and crushed) contained in root stems of dendrobium and Konjac (*Amorphophallus konja*). It is a mixture that consists of glucose and mannose.

Compositional Specifications of Glucomannan

Content Glucomannan (converted to a dried form) should contain not less than 90% of glucomannan.

Description Glucomannan is white ~ pale yellow powder

Identification (1) 6 g of Glucomannan is added to a 500 mL beaker. It is wetted with 10 mL of isopropyl alcohol. While stirring immediately, 200 mL of water is added. When it is set aside for 1 hour, it swells and becomes viscous solution.

(2) When 200 mL of 5% calcium hydroxide solution is added to viscous solution in (1), which is well mixed and then set aside, a gel is formed.

Purity (1) Arsenic : It should be no more than 4.0 ppm tested by Arsenic Limit Test.

(2) Lead : When 5.0 g of Glucomannan is tested by Atomic Absorption Spectrophotometry or Inductively Coupled Plasma Emission Spectroscopy, its content should not be more than 2.0 ppm.

(3) Isopropyl alcohol : 5 g of Glucomannan is precisely weighted into a 1,000 mL single neck round bottom flask with 24/40 ground joint, where 1 mL of anti foaming agent (Dow Corning G-10 or its equivalent) and 200 mL of water are added. It is then stirred for 1 hour. A 400 mL reflux condenser, distilling head, and a collector are attached. Approximately 95 mL of distillate is collected (care must be taken so that bubbles are not introduced into the collector). 4 mL of internal standard solution is added to the collected distillate, where water is added to bring the total volume to 100 mL (Test Solution). Test Solution and mixed standard solution are analyzed with gas chromatography and the amount of isopropyl alcohol is obtained by the following equation. The content should not be more than 500ppm. The reaction factor (f) is obtained by the ratio (A_{IPA} / A_{TBA}) of peak areas of isopropyl alcohol to *tert*-butyl alcohol in the mixed standard solution.

$$\text{Content of isopropyl alcohol (ppm)} = \frac{A_{IPA} \times 4,000}{f \times A_{TBA} \times \text{Weight of sample(g)}}$$

A_{IPA} : Peak area of isopropyl alcohol in Test Solution

A_{TBA} : Peak area of *tert*-butyl alcohol in Test Solution

Operation Conditions

-Column : A stainless steel tube 3.2 mm × 1.8 m

-Column Filler : Porapak QS of 80 ~ 100 mesh (or its equivalent)

-Detector : Flame Ionization Detector (FID)

- Temperature at injection hole : 200°C
- Column Temperature : 165°C
- Detector Temperature : 200°C
- Carrier gas and flow rate : Nitrogen, Flow rate is controlled so that isopropyl alcohol and tert-butyl alcohol is detected in 2 minutes and 3 minutes, respectively.

Solutions

- Mixed Standard Solution : A mixture of 4 mL IPA standard solution and 4 mL TBA standard solution is diluted to 100 mL with water. 1 mL of this solution contains 40µg each of isopropyl alcohol and tert butyl alcohol.
- IPA Standard Solution : Approximately 500 mg of isopropyl alcohol (chromatography grade) is precisely weighted and diluted to 50 mL with water. 10 mL of this solution is further diluted to 100 mL with water.
- TBA Standard Solution : Approximately 500 mg of *tert*-butyl alcohol (chromatography grade) is precisely weighted and diluted to 50 mL with water. 10 mL of this solution is further diluted to 100 mL with water.

(4) Viscosity : Viscosity of 1% aqueous solution of Glucomannan is measured by 2. Rotational Type Viscosity Measurement in Viscosity Measurement. It should be 500 cps or higher.

(5) Salmonella : When Glucomannan proceed as directed under Microbiological Methods for Salmonella in General Testing Methods in 「Standards and Specifications for Foods」, it should be negative (-).

(6) E. coli : When Glucomannan proceed as directed under Microbiological Methods for E. coli in General Testing Methods in 「Standards and Specifications for Foods」, it should be negative (-).

Loss on Drying When Glucomannan is dried for 3 hours at 105°C, the weight loss should not be more than 15%.

Ash When Glucomannan is tested for ash content, it should not be more than 4%.

Assay Same amount (0.5~1.0 g) each of Glucomannan (remove fat with ether if necessary) is placed separately in two 400 mL beakers. 50 mL each of phosphate buffer solution (pH 6.0) is added. Check the pH of the solution, and pH is adjusted to 6.0 ± 0.2 , if necessary. 0.1 mL of Termamyl solution is added to each beaker, which is covered with aluminum foil and heated for 30 minutes in a boiling water bath (shaken every 5 minutes). Using a thermometer, the temperature inside the beaker is maintained at 85~100°C for 15 minutes. Cool, and 10 mL of 0.275 N sodium hydroxide solution is added to each beaker and pH is adjusted to 7.5 ± 0.2 . 5 mg of protease (or 0.1 mL solution containing 50 mg of protease in 1 mL water) is added to the resulting solution. It is covered with aluminum foil and isothermalized for 30 minutes at 60°C while shaking continuously. Cool the solution, and pH is adjusted to 4.0~4.6 with 10 mL of 0.325 M hydrochloric acid and 0.3 mL of amylo glucosidase is added, which is then covered with aluminum foil and isothermalized for 30 minutes at 60°C while mixing by shaking.

280 mL of 95% alcohol (heated to 60°C) is added to the beaker and well mixed by shaking. It is then set aside for 1 hour at normal temperature to settle down glucomannan. A glass filter containing cellite (previously weighted) is wetted with 78% alcohol so that cellite is evenly distributed. It is vacuum filtered to evenly distribute the cellite. Test Solution (treated with enzyme) is then vacuum filtered through the glass filter. The residue is washed 3 times with 20 mL each of 78% alcohol, twice with 20 mL each of 95% alcohol, and twice with 10 mL each of acetone, in sequence. If a film is formed, it is broken with a reagent spoon to facilitate the filtration. Filtering time can be shortened if filtration is stopped occasionally. The filter is dried over night at $105 \pm 5^\circ\text{C}$, cooled in a desiccator, and weighted. The weight of the residue is obtained by subtracting the weight of glass filter. From the residue of one glass filter, the amount of proteins is obtained (Protein Factor : 6.25). The residue from another glass filter is ashed by heating for 5 hours at 525°C and ash content is obtained. Separately, a blank test is carried without sample. The content of glucomannan is obtained by the following equation.

$$\text{Blank Test Value B(mg)} = \text{Average weight of residue for blank test (mg)} - P_B - A_B$$

P_B : Amount of proteins for blank test (mg)

A_B : Amount of ash for blank test (mg)

$$\text{Content (\%)} = \frac{\text{Average weight of residue for blank test (mg)} - P - A - B}{\text{Average weight of sample (mg)}} \times 100$$

P : Weight of proteins (mg)

A : Weight of ash (mg)

B : Blank test value (mg)

Reagents and Solutions

- Phosphate Buffer Solution (pH 6.0) : 1.4 g of sodium phosphate, dibasic (anhydrous) and 9.68 g of sodium phosphate, monobasic (1 hydrate) are dissolved in 700 mL of water, which is diluted to 1,000 mL with water.
- 0.275 N sodium hydroxide solution : 11 g of sodium hydroxide is dissolved in 700 mL of water, which is diluted to 1,000 mL with water.
- 0.325 M hydrochloric acid : 325 mL of 0.1 M hydrochloric acid is diluted to 1,000 mL with water.
- Termamyl (thermostable- α -amylase) solution : No.120 L, Novo (refrigerated for storage)
- Protease : No.P - 3910, Sigma (refrigerated for storage)
- Amylo glucosidase : No. A - 9913, Sigma (refrigerated for storage)
- Cellite C - 211(Fischer) : washed with acid solution

Gluconic Acid

Gluconic Acid Solution

Synonyms: D-Gluconic acid; Dextransic acid

INS No.: 574

Definition Gluconic Acid is gluconic acid and glucono- δ -lactone solution.

Compositional Specifications of Gluconic Acid

Content Gluconic Acid should contain within a range of the equivalent of 50.0 ~ 52.0% of Gluconic Acid ($C_6H_{12}O_7 = 196.16$).

Description Gluconic Acid is a colorless to light yellow, clear syrupy liquid. It is odorless or has a slight odor, and has an acid taste.

Identification (1) When 1 drop of ferric chloride solution is added to 1 mL of Gluconic Acid solution (1 \rightarrow 25), a deep yellow color becomes.

(2) 4 mL of water is added to 1 mL of Gluconic Acid and proceed as directed under Identification (3) in 「Glucono- δ -Lactone」.

Purity (1) Chloride : 0.5 g of Gluconic Acid proceed as directed under Chloride Limit Test. It should not be more than amount that corresponds to 0.5 mL of 0.01 N hydrochloric acid.

(2) Sulfate : 1 g of Gluconic Acid proceed as directed under Sulfate Limit Test. It should not be more than amount that corresponds to 0.5 mL of 0.01 N hydrochloric acid.

(3) Arsenic : It should be no more than 4.0 ppm tested by Arsenic Limit Test.

(4) Lead : When 5.0 g of Gluconic Acid is tested by Atomic Absorption Spectrophotometry or Inductively Coupled Plasma Emission Spectroscopy, its content should not be more than 5.0 ppm.

(5) Mercury : When Gluconic Acid is tested by Mercury Limit Test, its content should not be more than 1.0 ppm.

(6) Sucrose or Reducing Sugar : To 1 g of Gluconic acid, add 10 mL of water and 2 mL of dilute hydrochloric acid and heat for 2 minutes. After cooling, 5 mL of sodium carbonate solution is added to the resulting solution, and cooled. which is then heated for 1 minutes in a water bath and cooled, immediately, orange yellow~red precipitates should not be formed.

Residue on Ignition When thermogravimetric analysis is done with 5 g of Gluconic Acid, the residue should not be more than 0.10%.

Assay Accurately weigh about 1 g of Gluconic Acid, add 30 mL of water and 40 mL of 0.1 N sodium hydroxide, shake, allow to stand for 20 minutes, and titrate the excess alkali with 0.1 N sulfuric acid (indicator : 3 drops of phenolphthalein solution). Separately, a blank test is carried out by the same procedure.

1 mL of 0.1 N sodium hydroxide = 19.616 mg of $C_6H_{12}O_7$

Glucono- δ -Lactone

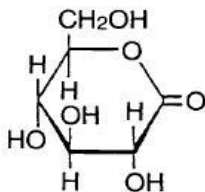

Chemical Formula: C₆H₁₀O₆

Molecular Weight: 178.15

INS No.: 575

Synonyms: Gluconolactone; GDL; D-Gluconic acid
delta-lactone

CAS No.: 90-80-2

Compositional Specifications of Glucono- δ -Lactone

Content Glucono- δ -Lactone, when calculated on the dried basis, should contain not less than 99.0% of glucono- δ -lactone (C₆H₁₀O₆).

Description Glucono- δ -Lactone occurs as white crystals or crystalline powder. It is odorless or has a slight odor. It has a sweet taste at first and changes to a slight acid taste.

Identification (1) The solution of Glucono- δ -Lactone (1 \rightarrow 50) is acidic.

(2) To 1 mL of Glucono- δ -Lactone solution (1 \rightarrow 10), add 1 drop of ferric chloride solution, the solution appears a deep yellow color.

(3) To 5 mL of Glucono- δ -Lactone solution (1 \rightarrow 10), add 0.7 mL of glacial acetic acid and 1 mL of freshly distilled phenylhydrazine, and heat in a water bath for 30 minutes and cool. When the inner wall is rubbed with a glass rod, crystals are precipitated. These crystals are collected and dissolved in 10 mL of hot water, where activated carbon is added. After mixing by shaking, it is filtered. After cooling, the inner wall is rubbed with a glass rod to precipitate crystals. The melting point of crystals, previously dried, should be within a range of 196~202°C (decomposition).

(4) 2.5 g of Glucono- δ -Lactone is dissolved in 25 mL of water. When optical rotation is immediately measured, it should be $[\alpha]_D^{20} = +60 \sim +67^\circ\text{C}$.

Purity (1) Clarity and Color of Solution : When 1 g of Glucono- δ -Lactone is dissolved in 10 mL of water, the solution should be colorless and not be more than almost clear.

(2) Chloride : When 0.5 g of Glucono- δ -Lactone is tested by Chloride Limit Test, its content should not be more than the amount that corresponds to 0.5 mL of 0.01 N hydrochloric acid.

(3) Sulfate : When 1 g of Glucono- δ -Lactone is tested by Sulfate Limit Test, its content should not be more than the amount that corresponds to 0.5 mL of 0.01 N sulfuric acid.

(4) Arsenic : It should be no more than 4.0 ppm tested by Arsenic Limit Test.

(5) Lead : When 5.0 g of Glucono- δ -Lactone is tested by Atomic Absorption Spectrophotometry or Inductively Coupled Plasma Emission Spectroscopy, its content should not be more than 2.0 ppm.

(6) Sucrose or Reducing Sugar : To 0.5 g of Glucono- δ -Lactone, add 10 mL of water and 2 mL of dilute hydrochloric acid, and boil for 2 minutes. After cooling, 5 mL of sodium carbonate solution is added, which is set-aside for 4 minutes. The solution is diluted to 20 mL with water, 5 mL of which is mixed with 2 mL of Fehling solution, which is boiled for 1 minute. An orange-yellow ~ red precipitate should not be formed immediately.

Loss on Drying When Glucono- δ -Lactone is dried for 2 hours at 105°C, the weight loss should not be more than 1%.

Residue on Ignition When thermogravimetric analysis is done with Glucono- δ -Lactone, the residue should not be more than 0.1%.

Assay Accurately weigh about 0.3 g of Glucono- δ -Lactone, precisely dried, and dissolve in 30 mL of 0.1 N sodium hydroxide solution. After the solution is set-aside for 20 minutes, the excess alkali is titrated with 0.1N sulfuric acid (indicator : 3 drops of phenolphthalein solution).

1 mL of 0.1 N sodium hydroxide solution = 17.82 mg of $C_6H_{10}O_6$

Glucosamine

Definition Glucosamine is obtained by one of the following processes. Chitin or chitosan are extracted from shells of crustacea (crabs, shrimps, etc.) or bones of mollusca (squid, cuttle fish, etc). Chitin or chitosan is hydrolyzed with hydrochloric acid. Or it Dissolve in hydrochloric acid then hydrolyzed with chitosanase. Hydrolyzed material is separated and purified.

Compositional Specifications of Glucosamine

Content Glucosamine should contain no less than 80.0% of glucosamine ($C_6H_{13}NO_5 = 179.17$).

Description Glucosamine is white powder.

Identification When 0.2 g of Glucosamine in a mixture of 5 mL of anthrone solution and 1 mL of water is heated in a water bath, it shows blue ~ green in color.

Purity (1) Arsenic : It should be no more than 4.0 ppm tested by Arsenic Limit Test.

(2) Lead : When 5.0 g of Glucosamine is tested by Atomic Absorption Spectrophotometry or Inductively Coupled Plasma Emission Spectroscopy, its content should not be more than 10.0 ppm.

(3) Clarity and Color of Solution : When 1 g of Glucosamine is dissolved in 20 mL of water, the solution should be clear.

(4) Acidity : pH of aqueous solution (10→100) of Glucosamine should be 3.0~5.0.

(5) Chloride : 0.1 g of Glucosamine is dissolved in 50 mL of methanol. Add 5 drops of potassium chromate solution(1→20) and the end point is the point where the color turns from yellow to reddish brown. When it is titrated by 0.1 N silver nitrate solution, the content which is calculated on the dried basis should be 16~18%.

1 mL of 0.1 N silver nitrate solution = 3.545mg Cl

(6) Total Viable Aerobic Count : When Glucosamine is tested by Microbe Test Methods for Total Viable Aerobic Count (Number of General Germs) in General Test Method in 「Standards and Specifications for Foods」, it should not be more than 300 per 1 g

(7) Coliform Group : When Glucosamine proceed as directed under Microbe Test Methods for Coliform Group in General Test Methods in 「Standards and Specifications for Foods」, it should be negative(-).

Loss on Drying When Glucosaminee is dried for 4 hours at 105°C, the weight loss should not be more than 1.0%.

Residue on Ignition Residue on Ignition should not be more than 1.0%.

pH pH of aqueous solution (1→100) should be 4.0~7.0 (measured by glass electrode).

Coliform Group Glucosamine is tested by Microbiological Methods for Coliform Group in General Testing Methods in 「Standards and Specifications for Foods」. It should be negative.

Assay 0.02 g of Glucosamine is precisely weighted and dissolved in 20 mL of water. It is then diluted to 100 mL with water (Test Solution). 1 mL of Test Solution transfer into a test tube with a stopper, where 2 mL of acetyl acetone is added. It is mixed and heated for 1 hour at 96°C. It is cooled in running water. 20 mL of 96% alcohol is added to this solution, where 2 mL of p-Dimethylaminobenzaldehyde is added

and mixed. The resulting solution is set aside for 1 hour at room temperature. Absorption (AT) at 535 nm is measured. Separately, a Standard Solution is prepared by dissolving D-glucosamine standard in water so that it contains 100~500 $\mu\text{g}/\text{mL}$. Absorption (AS) of 1 mL of Standard Solution is measured by the same procedure as Test Solution.

$$\text{Contents (\%)} = \frac{C \times 100}{\text{Weight of the sample(g)}} \times \frac{A_T}{A_S} \times \frac{100}{10^6}$$

C : Concentration of Standard Solution as glucosamine ($\mu\text{g}/\text{mL}$)

Solutions

- Acetyl acetone solution : 1.5 mL of acetyl acetone (purified by distillation, boiling point : 138~140°C) is mixed with 1.2 N sodium carbonate solution (total volume = 50 mL).
- ρ -Dimethylaminobenzaldehyde solution : 1.6 g of ρ -Dimethylaminobenzaldehyde dissolve in 30 mL of hydrochloric acid, where 30 mL of 96% alcohol is added.

α -Glucosidase

Definition α -Glucosidase is an enzyme obtained from cultures of *Aspergillus niger*. Dilutant or stabilizer can be added for the purpose of activity adjustment and quality preservation. α -Glucosidase cleaves the α -D-glycosidic bond between maltose or oligosaccharide and at the same time produce non-fermentable sugars by transfer reaction.

Compositional Specifications of α -Glucosidase

Description α -Glucosidase is white ~ dark brown power, granular, pasty substances or colorless ~ dark brown liquid.

Identification When α -Glucosidase is proceeded as directed under Activity Test, it should have the activity as α -Glucosidase.

Purity (1) Arsenic : It should be no more than 4.0 ppm tested by Arsenic Limit Test.

(2) Lead : When 5.0 g of α -Glucosidase is tested by Atomic Absorption Spectrophotometry or Inductively Coupled Plasma Emission Spectroscopy, its content should not be more than 5.0 ppm.

(3) Coliform Group : α -Glucosidase proceed as directed under Microbe Test Methods in Coliform Group in General Test Methods in 「Standards and Specifications for Foods」. It should contain not more than 30 colonies per 1 g of this product.

(4) Salmonella : When α -Glucosidase is tested by Microbe Test Methods for Salmonella in General Test Method 「Standards and Specifications for Foods」, it should be negative (-).

(5) E. Coli : When 25 g of α -Glucosidase is tested by Microbe Test Methods for E. Coli in General Test Method 「Standards and Specifications for Foods」, it should be negative (-).

Activity Test (activity)

Analysis principle : 4-Nitrophenyl- α -D-glucopyranoside substrate to produce p-nitrophenol by treating with α -Glucosidase at 40°C. Activity test is based on measuring absorbance of p-nitrophenol.

Preparation of Test Solution : Take the sample and add water to 10 mL of 1N diluted acetic acid •sodium acetate buffer solution(pH 5.0) to make to 1,000mL. Make the final diluent solution with using 1N diluted acetic acid •sodium acetate buffer solution to 0.5 mL. Test Solution is prepared so that the absorbance to be measured will be within a range of 0.25 ~ 0.95 under the following test method. The solution is prepared before use.

Procedure : Take 2 mL of substrate solution into tube, keep it at 40 \pm 0.5°C precisely for 5 minutes. Then add 0.5 mL of test solution and shake it to mix. Keep this solution at the constant temperature 40 \pm 0.5°C precisely for 15 minutes. Add 0.5 mL of 10% sodium carbonate solution to this solution and mix it. Cool it in ice bath for 5 minutes and keep it in running water until measure the absorbance. Using water as a reference solution, absorbance(A₁) is measured at wavelength 420 nm. Separately, take 0.5 mL of test solution for blank enzyme test into tube. After adding 0.5 mL of 10% sodium carbonate solution to this solution, mix it. Then add 2 mL of substrate solution and cool it in ice bath for 5 minutes and keep it in running water until measure the absorbance. Using water as a reference solution, absorbance(A₂) of

blank enzyme test solution is measured at wavelength 420 nm.

Activity of an enzyme is calculated by the following equation.

$$\alpha\text{-Glucosidase(units/g)} = (A_1 - A_2) \times F \times \frac{3}{0.5} \times \frac{1}{10} \times \frac{1}{W}$$

A_1 : Absorbance of enzyme reaction solution

A_2 : Absorbance of blank enzyme test solution

F : Amount of p-nitrophenol(When difference in absorption is 1.0 from standard curve)

10 : Reaction time(min)

W : Weight of sample in 1 mL of test solution(g)

Preparation of standard curve : Weigh 0.1391 g of p-nitrophenol and dissolve it in p-nitrophenol diluent solution, make to volume to 500 mL. Take precisely 0.5 mL, 1 mL, 1.5 mL, 2 mL, 2.5 mL of this solution. Then add p-nitrophenol diluent solution to each solution to make to 100 mL. This solution is used as each standard solution. 1 mL of each solution contains p-nitrophenol of 0.01, 0.02, 0.03, 0.04 and 0.05 $\mu\text{mol/mL}$. Using water as a reference solution, absorbance is measured at wavelength 420 nm. The concentration of p-nitrophenol($\mu\text{mol/mL}$) is plotted along the X axis and the absorbance is plotted along the Y axis. Prepare standard curve of enzyme activity.

Definition of Activity : 1 α -Glucosidase unit corresponds to the amount of enzyme which separates 1 μmol of p-nitrophenol from the substrate under the conditions above.

Reagent

Substrate solution : Dissolve 0.113 g of 4-Nitrophenyl- α -D-glucopyranoside in 35 mL of water. And add 5 mL of 1N acetic acid •sodium acetate buffer solution(pH 5.0) to this solution. Then add water to make to 50 mL. The solution is prepared before use.

1N acetic acid •sodium acetate buffer solution(pH 5.0) : After mixing 600 mL of 1N sodium acetate solution and 300mL of 1N acetic acid, adjust pH to 5.0 with 1N acetic acid.

p-nitrophenol diluent solution : Add water to 82 mL of 1N acetic acid •sodium acetate buffer solution(pH 5.0) to make to 1,000mL. Then add 200 mL of 10% sodium carbonate solution to this solution. The solution is prepared before use.

Storage Standard of α -Glucosidase

α -Glucosidase should be stored in a hermetic container in a cold dark place.

Glucose Isomerase

Definition Glucose Isomerase is an enzyme obtained from a culture of *Actinoplanes missouriensis*, *Bacillus coagulans*, *Microbacterium arborescens*, *Streptomyces olivaceus*, *Streptomyces olivochromogenes*, *Streptomyces rubiginosus*, *Streptomyces murinus*. Dilutant or stabilizer can be added for the purpose of activity adjustment and quality preservation.

Compositional Specifications of Glucose Isomerase

Description Glucose Isomerase is white ~ dark brown power, particles, pastes or colorless ~ dark brown liquid.

Identification When Glucose Isomerase is proceeded as directed under Activity Test, it should have the activity as Glucose Isomerase..

Purity (1) Arsenic : It should be no more than 4.0 ppm tested by Arsenic Limit Test.

(2) Lead : When 5.0 g of Glucose Isomerase is tested by Atomic Absorption Spectrophotometry or Inductively Coupled Plasma Emission Spectroscopy, its content should not be more than 5.0 ppm.

(3) Coliform Group : When Glucose Isomerase is proceeded as directed under Microbe Test Methods for Coliform Group in General Test Methods in 「Standards and Specifications for Foods」, it should contain not more than 30 colonies per 1 g of this product.

(4) Salmonella : When Glucose Isomerase is proceeded as directed under Microbe Test Methods for Salmonella in General Test Methods in 「Standards and Specifications for Foods」, it should be negative (-).

(5) E. Coli : When Glucose Isomerase is tested by Microbe Test Methods for E. Coli in General Test Method 「Standards and Specifications for Foods」, it should be negative (-).

Activity Test (activity)

Analysis Principle : Activity test is based on measuring conversion rate from glucose to fructose in a layered reactor. Test Procedure can be explained as initial velocity analysis method. Notable conditions are 45% w/w glucose extract, pH of inlet 7.0~8.5 at room temperature, 60°C temperature, and magnesium concentration of 4×10^{-3} M.

• **Preparation of Test Solution** : Sample is accurately weighed (g or mL) and transferred into a vacuum flask so that it contains 2,000~8,000 Glucose isomerase unit (GlcU), where 200 mL of substrate solution are added and mixed for 15 seconds. The mixture is stirred in a 5 minute interval for 40 minutes. It is then degassed for 30 minutes in vacuum. In case where the sample is liquid, it is adsorbed on resin prior to use as follows. Strongly alkaline anion exchange resin (IRA 90) is washed with water for 4 hours and pH is adjusted to 7.0 ~ 9.0. This is taken 80 mL, packed into a glass column, and added again 50 mL of water to the column. Sample, corresponding to 10,000 GlcU, accurately weighed, and added. Finally, the column is washed with 10 mL of water. The flow rate is adjusted to 2 mL/minute before the sample is added. Once the sample is added, the effluent is re-entered into the top of the column and it is circulated for 8 hours at room temperature so that the sample is adsorbed on the resin. 40 mL of sample

adsorbed on the resin is into a vacuum flask and proceed as directed under the rest of the procedure described here.

- Test Procedure : Based on the activity estimate of a sample, a substrate flow rate is adjusted to 0.2 ~ 0.3 per 1 fractional transformation. Fractional transformation is obtained from the value of specific rotation on the initial substrate and the effluent as the following equations. Once the exact flow rate is determined, the column is run for 1 full day (at least for 16 hours) and pH of the substrate solution is monitored. If necessary, flow rate is adjusted. Flow rate is measured and the effluent is collected, which is covered and allow to stand for 30 minutes at room temperature. Fractional transformation from glucose to fructose is obtained from the following equation. If the transformation is not more than 0.2 or not less than 0.3, the flow rate is adjusted so that it falls within this range .In case where flow rate needs to be adjusted, the column is re-equilibrated for 2 hours or more, the additional effluent is collected and fractional transformation is obtained. The flow rate is measured and the effluent is allowed to stand for 30 minutes with a cover and fractional transformation is obtained.
- Specific Rotation : Optical rotations for the effluent and the initial substrate are measured at 25°C, and specific rotations are calculated from the following equation.

$$[\alpha] = \frac{100a}{l_{pd}}$$

a : Observed optical rotation

l : Length of sample tube (dm)

p : Concentration of Test Solution (g/100g solution)

d : Specific gravity of the solution at 25°C

Fractional conversion : Fractional conversion X is calculated from the following equation.

$$X = \frac{(\alpha_E - \alpha_S)}{(\alpha_F - \alpha_S)}$$

α_E : Specific Rotation of the column effluent

α_S : Specific Rotation of glucose substrate

α_F : Specific Rotation of fructose (in this case, -94.54)

Activity of enzyme is obtained from the following equation.

$$\text{GlcU/g or mL} = \frac{FS}{W} \times X_E \times \ln\left[\frac{X_E}{X_E - X}\right]$$

- F : Flow rate (mL/min)
S : Concentration of glucose ($\mu\text{mol/mL}$)
X : Fractional conversion
XE : Fractional conversion at equilibrium or 0.51
W : amount of sample(g, mL)

Definition of Activity : Activity of an enzyme is expressed as Glucose isomerase unit (GlcU, c indicates Column Treatment Test Method). 1 GlcU corresponds to the amount of enzyme that isomerizes glucose into fructose under the above conditions at a lowest ratio of 1 μmol per minute.

Apparatus : Column apparatus is depicted as below. A coarse glass filter is attached to the bottom and warm water is circulated by a circulation pump through a double tube (2.5cm inner diameter x 40cm length) that is connected to a water bath at 60°C. An peristaltic pump with an inverter (maximum flow rate of 800 mL/h) is attached to the column. An inner diameter of the tube, that is connected to the peristaltic pump should be adjustable the flow rate as 60 to 150 mL/h. The connector of outlet of column is connected to a collection container. (Note : all the connecting parts should be made of glass or chemically inert plastic.)

Preparation of Column

Test Solution is transferred to the column using magnesium sulfate solution. The solution is allowed to stand so that enzymes are settled down, upon which a porous plate is placed. Air adsorbed on the plate should be removed. The top of the plate is filled with cotton ball to a thickness of 1 ~ 2 cm. This acts as a filter that removes bubbles generated from glucose substrate and keeps the solution temperature constant. The tube, that is connected to the peristaltic pump with an inverter, is connected to the column inlet and sealed connector to prevent to let air in. The connector to the pump inlet is inserted into the substrate solution. The flow rate is adjusted to at least 80 mL per hour with a pump. This is maintained for 1 hour at room temperature.

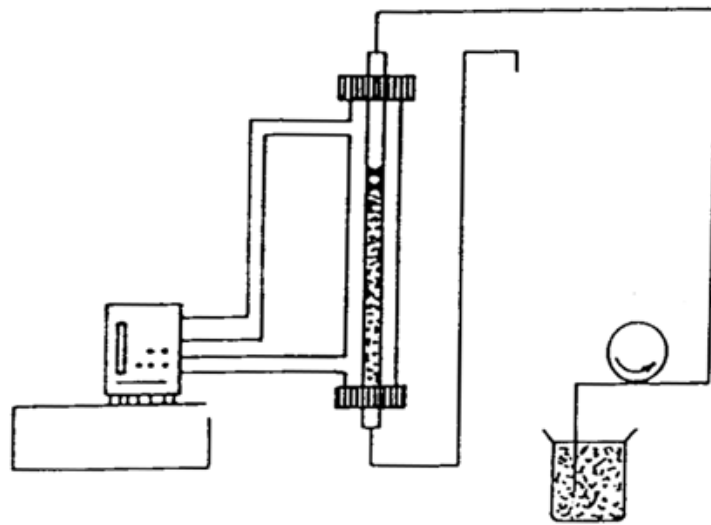

Column apparatus for analysis of glucose isomerizing enzyme

Solution

- Substrate Solution : 539 g of glucose and 1.0 g of magnesium sulfate ($\text{MgSO}_4 \cdot 7\text{H}_2\text{O}$) are dissolved in 700 mL of water ($50\sim 60^\circ\text{C}$). This solution is cooled to room temperature and the pH is adjusted to $7.0\sim 8.5$. The total volume is made to 1,000 mL with water, which is degassed under a reduced pressure for 30 minutes.
- Magnesium Sulfate Solution : 1 g of magnesium sulfate is dissolved in water and pH is adjusted to $7.5\sim 8.0$ with 1 N sodium hydroxide solution. The total volume is brought up to 1,000 mL with water.

Storage Standard of Glucose Isomerase

Glucose Isomerase should be stored in a hermetic container in a cold dark place.

Glucose Oxidase

Definition Glucose oxidase is an enzyme obtained from a culture of *Aspergillus niger*, *Penicillium chrysogenum* and its variety, respectively. Dilutant or stabilizer can be added for the purpose of activity adjustment and quality preservation.

Compositional Specifications of Glucose Oxidase

Description Glucose oxidase is white to dark brown power, particles and pastes or colorless to dark brown liquid.

Identification When Glucose oxidase is proceeded as directed under Activity Test, it should have the activity as Glucose oxidase.

Purity (1) Arsenic : It should be no more than 4.0 ppm tested by Arsenic Limit Test.

(2) Lead : When 5.0 g of Glucose Oxidase is tested by Atomic Absorption Spectrophotometry or Inductively Coupled Plasma Emission Spectroscopy, its content should not be more than 5.0 ppm.

(3) Coliform Group : When Glucose oxidase is proceeded as directed under Microbe Test Methods for Coliform Group in General Test Methods in 「Standards and Specifications for Foods」, it should contain not more than 30 colonies per 1 g of this product.

(4) Salmonella : When Glucose oxidase is proceeded as directed under Microbe Test Methods for Salmonella in General Test Methods in 「Standards and Specifications for Foods」. it should be negative (-).

(5) E. Coli : When Glucose oxidase is tested by Microbe Test Methods for E. Coli in General Test Method 「Standards and Specifications for Foods」. it should be negative (-).

Activity Test (activity)

Analysis Principle : Activity test is based on titration of gluconic acid which is produced under the presence of excess amount of substrate and air.

◦ Preparation of Test Solution : Sample is diluted with chloride acetate buffer solution (pH 5.1), so that 1 mL of the solution contains 5 ~ 7 GOTU.

◦ Test Procedure : 25 mL of substrate solution is added in a 32 × 200 mm test tube and isothermalized for 20 minutes in a water bath at $35 \pm 1^\circ\text{C}$. 3 mL of Test Solution is added and mixed by shaking. A glass sparger, previously control air flow of 700 ~ 750 mL per minute, is inserted into the test tube. If excess bubbles are generated, 3 drops of octadecanol solution are added. Glass sparger is removed exactly after 15 minutes and washed with water, which is added into the test tube. 10 mL of 0.1 N sodium hydroxide solution and 3 drops of phenolphthalein TS are added immediately, which is then stirred with a magnetic stir bar. It is then titrated 0.05 N hydrochloric acid. The consumption of hydrochloric acid (mL) for test solution is S. Separately, a blank test is carried out with 25 mL of chloride acetate buffer solution (pH 5.1) instead of substrate solution and the consumption of hydrochloric acid (mL) is B. Activity of the enzyme is obtained by the following equation.

$$\text{GOTU/g} = \frac{(\text{B} - \text{S}) \times \text{N} \times 180 \times \text{F}}{3 \times \text{W}}$$

N : Normality of 0.05 N hydrochloric acid

F : Dilution factor

W : Weight of sample contained in 1 mL of Test Solution (g)

180 : Molecular weight of glucose

3 : Conversion factor to a defined unit

Definition of Activity : 1 Glucose oxidase titrimetric unit(GOTU) corresponds to the amount of enzyme which oxidizes 3 mg of glucose to gluconic acid under the test condition above.

Solutions

- Phenolphthalein TS : 2 g of phenolphthalein is dissolved in 100 mL of methyl alcohol.
- Octadecanol Solution : Saturated octadecanol solution in methyl alcohol.
- Chloride-acetate buffer solution (pH 5.1) : 2.92 g sodium chloride and 4.1 g sodium acetate are dissolved in 900 mL of water. pH of the solution is adjusted to 5.1 with diluted acetic acid or sodium hydroxide solution. The total volume is make to 1,000 mL with water
- Substrate Solution : 30 g of glucose (anhydrous) is dissolved in chloride-acetate buffer solution (pH 5.1) so that the total volume is 1,000 mL.

Storage Standard of Glucose Oxidase

Glucose Oxidase should be stored in a hermetic container in a cold dark place.

L-Glutamic Acid

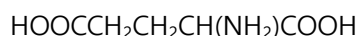

Chemical Formula: $\text{C}_5\text{H}_9\text{NO}_4$

Molecular Weight: 147.13

INS No.: 620

Synonyms: Glutamic acid; L- α -Aminoglutaric acid

CAS No.: 56-86-0

Compositional Specifications of L-Glutamic Acid

Content L-Glutamic Acid, when calculated on the dried basis(anhydrous), should contain not less than 99.0% of L-glutamic acid ($\text{C}_5\text{H}_9\text{NO}_4$).

Description L-Glutamic Acid occurs as colorless to white crystals or white crystalline powder having a slightly characteristic taste and acid taste.

Identification (1) Dissolve 0.15 g of L-Glutamic Acid in a mixture of 4 mL of water and 1 mL of sodium hydroxide solution, and add 1 mL of ninhydrine solution (0.2→100). and 0.1 g of sodium acetate. When it is heated for 10 minutes in a water bath, the solution becomes dark bluish violet.

(2) 1 g of L-Glutamic Acid is suspended in 9 mL of water. When 5.6 mL of 1 N hydrochloric acid or 6.8 mL of 1 N sodium hydroxide solution is added, it is completely dissolved.

Purity (1) Specific Rotation : 10 g of L-Glutamic Acid, precisely dried and accurately weighed, is dissolved in 2 N hydrochloric acid to make 100 mL and its optical rotation should be within a range of $[\alpha]_D^{25} = +31.5 \sim +32.2^\circ$.

(2) Lead : When 5.0 g of L-Glutamic Acid is tested by Atomic Absorption Spectrophotometry or Inductively Coupled Plasma Emission Spectroscopy, its content should not be more than 1.0 ppm.

(3) Arsenic : It should be no more than 4.0 ppm tested by Arsenic Limit Test.

(4) Pyrrolidone Carboxylic Acid : Dissolve 1g of L-Glutamic Acid in 100 mL of water, test solution. Separately, 1 g of pyrrolidone carboxylic acid dissolve in water, reference solution. Drop $1\mu\text{l}$ of test solution and reference solution on Thin Layer Plate prepared by using silica gel for thin-layer chromatography and develop about 10cm by using n-butanol: glacial acetic acid : water mixture (2:1:1) as developing solvent. Thin Layer Plate is dried at 80°C for 30 minutes . Spray color developing solution to it and heat it for at 80°C for 10 minutes. Pyrrolidone carboxylic acid spot in test solution should not be observed at the same position as reference solution.

Color Developing solution : To 1g of Ninhydrin and 3mL of acetic acid, n-butanol is added to bring the total volume to 100 mL.

Loss on Drying When L-Glutamic Acid is dried for 3 hours at 80° , the weight loss should not be more than 0.2%.

Residue on Ignition When thermogravimetric analysis is done with L-Glutamic Acid, the residue should

not be more than 0.2%.

Assay Proceed as directed under Assay in 「L-Sodium Glutamate」.

1 mL of 0.1 N perchloric acid = 14.71 mg of $C_5H_9NO_4$

Glutaminase

Definition Glutaminase is the enzyme, which is obtained from the culture of *Bacillus subtilis*, *Bacillus amyloliquefaciens*, *Aspergillus* sp and *Candida* sp. Diluent or stabilizer can be added for the purpose of activity adjustment and quality preservation.

Compositional Specifications of Glutaminase

Description Tannase is a white ~ pale yellow powder.

Identification When Glutaminase is proceeded as directed under Activity Test, it should have the activity as Glutaminase.

Purity (1) Arsenic : It should be no more than 4.0 ppm tested by Arsenic Limit Test.

(2) Lead : When 5.0 g of Glutaminase is tested by Atomic Absorption Spectrophotometry or Inductively Coupled Plasma Emission Spectroscopy, its content should not be more than 5.0 ppm.

(3) Coliform Group: Glutaminase is tested by Microbiological Method for [Coliform Group] in General Testing Methods in 「Standards and Specifications for Foods」. It should contain not more than 30 per 1g of this product.

(4) Salmonella : Glutaminase is tested by Microbiological Method for [Salmonella] in General Testing Methods in 「Standards and Specifications for Foods」. It should be negative(-).

(5) E. Coli : When Glutaminase is tested by Microbe Test Methods for E. Coli in General Test Method 「Standards and Specifications for Foods」, it should be negative (-).

Activity Test (activity) Analysis Principle : The activity test is based on the hydrolysis of L- γ -glutamyl-p-nitroanilide substrate for 10minutes at 37°C(pH 6.0). Produced p-nitroaniline is measured by the Absorbance Test.

Preparation of Test Solution : Sample dissolve in diluted solution. Following below method, Test Solution should be prepared in order that the difference of Absorbance(As -Ab) is 0.3 ~ 1.0.

Standard Curve : Add 0.0414g of p-nitroaniline, 6g of acetic acid and 10mL of 1M acetate..sodium acetate buffer solution. Make up 100mL with water. 3 μ mol of p-Nitroaniline per 1mL should be contained in the solution. Dilute to contain 0.025, 0.05, 0.075, 0.1 and 0.125 μ mol by using 1.1M acetate.sodium acetate buffer solution. Control Solution is 1.1M acetate.sodium acetate buffer solution. The absorbance is measured with 1cm of its liquid layer at 410nm. The concentrate of p-Nitroaniline(F, μ mol/mL) is calculated by the difference 1.000.

Test Procedure : 4 mL of substrate solution is added to a 25 × 150mm test tube(for enzyme test) and isothermalized for 5 minutes in a 37 ± 0.2°C water bath. 0.5mL of Test Solution is promptly taken in the test tube, and shaken. Set aside again the water bath. After 10minutes, the reaction of the enzyme is stopped by 0.5mL of 10M acetic acid. 0.5mL of 10M acetic acid is added in the test tube for Enzyme Blank Test. Shake and add 0.5mL of Test Solution. Stir and isothermalize for 10minutes in the water bath. Control Solution is Enzyme Blank Test Solution and the absorbance is measured with 1cm of its liquid layer at 410nm. The enzyme activity is calculated following the formula.

$$\text{Glutaminase(GSU/g)} = (\text{As}-\text{Ab}) \times \text{F} \times \text{D}$$

F : The concentrate of p-nitroaniline($\mu\text{mol/mL}$), as the difference of absorbance obtained from Standard curve is 1.000

D : The dilution factor of sample

Definition of Activity : 1 Glutaminase unit corresponds to the amount of enzyme, which isolated from $1\mu\text{mol}$ of p-nitrophenol per minutes under the above test conditions

Solution

Substrate Solution : 0.0285g of L- γ -glutamyl-p-nitroanilide is weighted and dissolved in 0.2mL of 2N hydrochloric acid. Add approximately 70mL of water. 10mL of 1M acetate .sodium acetate buffer solution(pH 6.0) and 0.2mL of 2N sodium hydroxide are added in the solution. Make up 100mL with water. This solution is prepared freshly before use.

2N hydrochloric acid : 16.7 mL of hydrochloric acid dissolve with water to make up 100mL.

2N sodium hydroxide : 8g of sodium hydroxide dissolve with water to make up 100mL.

1M acetic acid : 60g of acetic acid dissolve in water to make 1,000 mL volume

1M sodium acetate solution : 136g of sodium acetate(three hydrous) dissolve in water to make 1,000 mL volume

1M acetate .sodium acetate buffer solution(pH 6.0) : 1M acetate is added in 1M sodium acetate. Adjust to pH 6.0

1M acetate .sodium acetate buffer solution : 60g of acetate and 100mL of 1M acetate .sodium acetate buffer solution(pH 6.0) are added in water to make 1,000 mL volume.

10% TRITON X-100 solution : 10g of TRITON X-100 is added in 70mL of water. dissolve to heat. Cool the solution, add water to make 100mL volume.

Diluted solution : 5.84g of sodium chloride dissolve in water. Add 100mL of 1M acetate .sodium acetate buffer solution(pH 6.0) and 1mL of 10% TRITON X-100 solution. Make 1000mL volume with water.

Stotage standard of Glutaminase

Glutaminase should be stored in a hermetic container in a cold dark place.

L-Glutamine

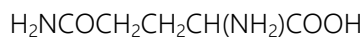

Chemical Formula: $\text{C}_5\text{H}_{10}\text{N}_2\text{O}_3$

Molecular Weight: 146.15

CAS No.: 56-85-9

Compositional Specifications of L-Glutamine

Content L-glutamine, when calculated on the dried basis, should contain within a range of 98.5 ~ 101.5% L-glutamine ($\text{C}_5\text{H}_{10}\text{N}_2\text{O}_3$).

Description L-glutamine is scentless white crystallite or crystalline powder with a slight sweet taste.

Identification 1 mL of ninhydrine standard solution is added to 5 mL aqueous solution of L-glutamine (1→1,000). Upon heating for 3 minutes in a water bath, this solution turns violet.

Purity (1) Specific Rotation : 4 g of pre-dried material is precisely weighed and dissolved in water (total volume 100 mL). The polarity of this solution should be within a range of $[\alpha]_D^{20} = +6.3 \sim +7.3^\circ$

(2) Lead : When 5.0 g of L-Glutamine is tested by Atomic Absorption Spectrophotometry or Inductively Coupled Plasma Emission Spectroscopy, its content should not be more than 5 ppm.

(3) Arsenic : It should be no more than 4.0 ppm tested by Arsenic Limit Test.

(4) Chloride: When 0.07 g of L-Glutamine is tested by Chloride Limit Test, its content should not be more than the amount that corresponds to 0.2 mL of 0.01 N hydrochloric acid.(Not be more than 0.1%)

Loss on Drying When L-glutamine is dried for 3 hours at 105°C, the loss should not be more than 0.3%.

Residue on Ignition Residue after ignition should not be more than 0.1%.

Assay Accurately weighed about 0.5 g of L-glutamine, and proceed as directed under Assay of [L-Sodium Glutamate].

1 mL of 0.1 N perchloric acid solution = 14.62 mg $\text{C}_5\text{H}_{10}\text{N}_2\text{O}_3$

Glycerin

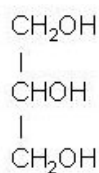

Chemical Formula: $\text{C}_3\text{H}_8\text{O}_3$

Molecular Weight: 92.09

INS No.: 422

Synonyms: Glycerol; Glycerine

CAS No.: 56-81-5

Compositional Specifications of Glycerin

Content Glycerin, when calculated on the anhydrous basis, should contain not less than 99.0% of glycerin ($\text{C}_3\text{H}_8\text{O}_3$).

Description Glycerin is a colorless and odorless liquid with sweet flavor.

Identification To 2 ~ 3 drops of Glycerin, add 0.5 g of potassium hydrogen sulfate and heating, pungent odor of acrolein is generated.

Purity (1) Chloride : When 3.5 g of Glycerin tested by Chloride Limit Test, the content should not be more than the amount that corresponds to 0.1 mL of 0.01 N hydrochloric acid.

(2) Arsenic : It should be no more than 4.0 ppm tested by Arsenic Limit Test.

(3) Lead : When 5.0 g of Glycerin is tested by Atomic Absorption Spectrophotometry or Inductively Coupled Plasma Emission Spectroscopy, its content should not be more than 2.0 ppm.

(4) Cadmium : When 5.0 g of Glycerin is tested by Atomic Absorption Spectrophotometry or Inductively Coupled Plasma Emission Spectroscopy, its content should not be more than 1.0 ppm.

(5) Mercury : When Glycerin is tested by Mercury Limit Test, its content should not be more than 1.0 ppm.

Water Content Water content of Glycerin proceed as directed under Water Determination (Karl-Fisher Titration) and should not be more than 5.0%.

Residue on Ignition To 10 g of Glycerin, add 1 ~ 2 drops of sulfuric acid and slowly ignited by heating. The residue proceed as directed under Thermogravimetric Analysis, its content should not be more than 0.01%

Assay To 0.5 g of Glycerin, quickly and accurately weighed, add water to make 500 mL. Take 50 mL of this solution, add about 200 mL of water. Then, the pH of this solution is adjusted to 7.9 ± 0.1 using dilute sulfuric acid (3→1,000) or dilute sodium hydroxide (1→250). Add 50 mL of sodium periodate solution for glycerin and mix, which is then kept with a watch glass cover in a dark place for 30 minutes.

Then 10 mL of 1:1 mixture of ethylene glycol and water is added and stir-mixed, which is again kept in a dark place for 20 minutes. Add 5 mL of sodium formate solution (1→15) and titrate with 0.1 N sodium hydroxide solution until reaches pH of 7.9 ± 0.2 . A blank test is done separately. Water used in this test is to be freshly boiled and cooled prior to use.

1 mL of 0.1 N Sodium Hydroxide Solution = 9.209 mg $C_3H_8O_3$

Glycerin Esters of Fatty Acids

Chemical Formula:

Synonyms: Glycerin fatty acid esters; Mono- and di- glycerides of fatty acids; Acetic and fatty acid esters of glycerol; Lactic and fatty acid esters of glycerol; Citric and fatty acid esters of glycerol; Diacetyltartaric and fatty acid esters of glycerol; Polyglycerol esters of fatty acids; Polyglycerol esters of interesterified ricinoleic acid; Succinylated monoglycerides

INS No.: 471, 472a, 472b, 472c,
472e, 475, 476, 472g

Definition Glycerin Esters of Fatty Acids are esters of fatty acids and glycerin or polyglycerin and their derivatives. Glycerin Esters of Fatty Acids include glycerin fatty acid ester, glycerin acetic acid fatty acid ester, glycerin lactic acid fatty acid ester, glycerin citric acid fatty acid ester, glycerin succinic acid fatty acid ester, glycerin diacetyl tartaric acid fatty acid ester, glycerin acetic acid ester, polyglycerin fatty acid ester, and polyglycerin condensed ricinoleic acid ester.

Content Specifications of Glycerin Esters of Fatty Acids

Description Glycerin Esters of Fatty Acids occur as colorless to brown powders, flakes, coarse powders, or granular or waxy lumps, or are a colorless to brown semi-fluids or liquids. They are odorless or have a characteristic odor.

Identification (1) To approximately 5 g of Glycerin Ester of Fatty Acid (in case of glycerol acetic acid ester, 1.5 g), add 50 mL of ethanolic potassium hydroxide solution, equip with a reflux condenser, heat in a water bath for 1 hour, and evaporate the ethanol to an almost dry state. Then, add 50 mL of diluted hydrochloric acid (1→9), shake well, and separate the produced fatty acid by extracting three times with 40 mL of petroleum ether.methyl ethyl ketone mixture (7 : 1) each time. Stir the water layer well, add sodium hydroxide solution (1→9) until it is almost neutral, and concentrate under reduced pressure in a water bath. Add 20 mL of methanol at about 40°C, shake well, cool, filter, and evaporate the methanol of the filtrate in a water bath. Perform Thin-Layer Chromatography on 5µl of the test solution, using a solution (1→10) of the residue dissolved in methanol as the test solution. methanol glycerin mixture (9:1) as the reference solution, and, n-butanol.methanol.chloroform mixture (5:3:2) as the developing solvent. In cases of glycerin esters, a white spot is observed at the same position as the reference solution and in cases of polyglycerin ester, a white spot or a white band-shaped spot is observed at a position not above that of the reference solution. For the thin layer plate. use silica gel for thin-layer chromatography dried at 110°C for 1 hour as the support. Stop the development when the solvent front rises 15 cm above the original line. Air-dry, heat at 110°C for 10 minutes to remove

the solvent, cool, spray the thymol.sulfuric acid solution, and heat at 110°C for 20 minutes to develop the color.

- (2) Except in the case of glycerin acetic acid ester : Combine the petroleum ether-methyl ethyl ketone layers obtained by separation in (1) above, and evaporate the solvent. An oily substance or a white to yellow-white solid remains. When add 5 mL of ether to 0.1 g of the residue and shake, it is dissolves.
- (3) Except in the cases of glycerin fatty acid ester and polyglycerin ester : Add 50 mL of water to 5 mL of the test solution of (1) above, and shake. in cases of glycerin acetic acid fatty acid ester and glycerin acetic acid ester, the solution responds to the test for Acetate; in the case of glycerin lactic acid fatty acid ester, to that for Lactate; in the case of glycerin citric acid fatty acid ester, to that for Citrate (B); in the case of glycerin succinic acid fatty acid ester, to that for Succinate; and in the case of glycerin diacetyl tartaric acid fatty acid ester, to those for Acetate and Tartrate, respectively.
- (4) In case of polyglycerin condensed ricinoleic acid ester: Combine the petroleum ether-methyl ethyl ketone layers obtained by separation in (1) above. Wash this solution twice with 50 mL of water each time, dehydrate with anhydrous sodium sulfate, filter, and remove the solvent by warming under reduced pressure. When accurately weigh about 1 g of the residue, put this into a 200mL round bottom-type flask and proceed as directed under Hydroxyl Value in Fats and Related Substances, the hydroxyl value is 150 ~ 170. For measuring acid value, use about 0.5 g of the residue.

Purity (1) Acid Value : Dissolve about 6 g of Glycerin Esters of Fatty acid, accurately weighed, in a mixture of ethanol and ester (1:1) and proceed as directed under Acid Value in Fats and Related substances Tests. Glycerin fatty acid ester, Glycerin acetic acid fatty acid ester, Glycerin lactic acid fatty acid ester, Glycerin acetic acid ester should not be more than 6.0, Polyglycerin fatty acid ester, Polyglycerin condensed ricinoleic acid ester should not be more than 12, Glycerol citric acid fatty acid ester should not be more than 100, Glycerin succinic acid fatty acid ester, Glycerin diacetyl tartaric acid ester should not be more than 60 ~ 120.

- (2) Arsenic : It should be no more than 4.0 ppm tested by Arsenic Limit Test.
- (3) Lead : When 5.0 g of Glycerin Esters of Fatty acid is tested by Atomic Absorption Spectrophotometry or Inductively Coupled Plasma Emission Spectroscopy, its content should not be more than 2.0 ppm.
- (4) Cadmium : When 5.0 g of Glycerin Esters of Fatty acid is tested by Atomic Absorption Spectrophotometry or Inductively Coupled Plasma Emission Spectroscopy, its content should not be more than 1.0 ppm.
- (5) Mercury : When Glycerin Esters of Fatty acid is tested by Mercury Limit Test, its content should not be more than 1.0 ppm.
- (6) Polyoxyethylene : Weigh 1 g of Glycerin Esters of Fatty Acids, transfer into a 200 mL flask, add 25 mL of ethanolic potassium hydroxide solution, equip with a ground reflux condenser, and boil on a water bath for 1 hour while shaking occasionally. Evaporate the ethanol on a water bath or under reduced pressure until it becomes almost dry, add 20 mL of diluted sulfuric acid (3→100), shake well while

warming, add 15 mL of ammonium thiocyanate cobalt nitrate solution, shake well, add 10 mL of chloroform, shake again, and allow to stand. The color of the chloroform layer does not change to blue.

Residue on Ignition When 1 g of Glycerin Esters of Fatty Acids, accurately weighed, is tested by thermogravimetric analysis at $800 \pm 25^\circ\text{C}$, the amount of residue should not be more than 0.5%.

Glycine

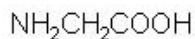

Chemical Formula: $\text{C}_2\text{H}_5\text{O}_2\text{N}$

Molecular Weight: 75.07

INS No.: 640

Synonyms: Aminoacetic acid

CAS No.: 56-40-6

Compositional Specifications of Glycine

Content Glycine, when calculated on the dried basis, contains 98.5 ~ 101.5% of glycine ($\text{C}_2\text{H}_5\text{O}_2\text{N}$).

Description Glycine occurs as white crystals or crystalline powder, having a sweet taste.

Identification (1) To 5 mL of solution of Glycine (1→10), add 5 drops of dilute hydrochloric acid and 1 mL of sodium nitrite solution, colorless gas is generated.

(2) Take 5 drops of the resulting solution above (1), transfer into small test tube and boil for a while and evaporate to dryness in a drying oven at 120°C and cool. To dried residues, add 5 ~ 6 drops of chromotropic acid, which is then heated for 10 minutes in a water bath. The solution shows a deep violet color.

(3) To 5 mL of Monosodium L-Glutamate solution (1→1,000), add 1 mL of ninhydrin solution (1→1,000), and heat for 3 minutes. A purple color develops.

Purity (1) Clarity and Color of Solution : When dissolve 1 g of Glycine in 10 mL of water, it should be colorless and clear.

(2) pH : pH of Glycine solution (1→10) is within a range of 5.5 ~ 7.0.

(3) Chloride : When 0.5 g of Glycine is tested by Chloride Limit Test, the content should not be more than the amount that corresponds to 0.3 mL of 0.01N hydrochloric acid.

(4) Arsenic : It should be no more than 4.0 ppm tested by Arsenic Limit Test.

(5) Lead : When 5.0 g of Glycine is tested by Atomic Absorption Spectrophotometry or Inductively Coupled Plasma Emission Spectroscopy, its content should not be more than 5.0 ppm.

(6) Mercury : When Glycine is tested by Mercury Limit Test, its content should not be more than 1.0 ppm.

Loss on Drying When Glycine is dried for 3 hours at 105°C, the weight loss should not be more than 0.2%.

Residue on Ignition 1 g of Glycine proceed as directed under Residues on ignition, it should not be more than 0.1%.

Assay Accurately weigh about 0.15 g of Glycine and dissolve in 3 mL of formic acid. Add 50 mL of glacial acetic acid, and titrated with 0.1 N perchloric acid (indicator : 0.5 mL of α -naphtholbenzein solution).

The end point is where the solution changes its color from brown to green. Separately, a blank test is carried out by the same method.

1 mL of 0.1 N perchloric acid = 7.507 mg of $C_2H_5O_2N$

β-Glycosidase

Definition β-Glycosidase is the enzyme, which is obtained from the culture of *Penicillium multicolor*. Diluent or stabilizer can be added for the purpose of activity adjustment and quality preservation.

Compositional Specifications of β-Glycosidase

Description Tannase is a white ~ pale yellow powder.

Identification When β-Glycosidase is proceeded as directed under Activity Test, it should have the activity as β-Glycosidase.

Purity (1) Arsenic : It should be no more than 4.0 ppm tested by Arsenic Limit Test.

(2) Lead : When 5.0 g of β-Glycosidase is tested by Atomic Absorption Spectrophotometry or Inductively Coupled Plasma Emission Spectroscopy, its content should not be more than 5.0 ppm.

(3) Coliform Group: β-Glycosidase is tested by Microbiological Method for [Coliform Group] in General Testing Methods in 「Standards and Specifications for Foods」. It should contain not more than 30 per 1g of this product.

(4) Salmonella : β-Glycosidase is tested by Microbiological Method for [Salmonella] in General Testing Methods in 「Standards and Specifications for Foods」. It should be negative(-).

(5) E. Coli : When β-Glycosidase is tested by Microbe Test Methods for E. Coli in General Test Method 「Standards and Specifications for Foods」, it should be negative (-).

Activity Test (activity) Analysis Principle: The activity test is based on the hydrolysis of 4-Nitrophenyl-primeveroside substrate for 10minutes at 40°C(pH 5.5).

Preparation of Test Solution : Sample dissolve in 20mM of acetic acid buffer solution. Following below method, Test Solution should be prepared in order that the range of absorbance is 0.3 ~ 0.7.

Test Procedure : 2.0 mL of substrate solution is added to a 25 × 150mm test tube(for enzyme test) and isothermalized for 5 minutes in a 40°C water bath. 0.45mL of Test Solution is added in the test tube, and shaken. Isothermalize again for 10 minutes in a 40°C water bath, and add 2.5mL of 0.5M sodium carbonate. Separately, 2mL of Substrate Solution is added in the test tube for Enzyme Blank Test, and isothermalized for 5 minutes in a 40°C water bath. Add 2.5mL of 0.5M sodium carbonate. Cover with appropriate stopper. Up side down several times and shake. Add 0.45mL of Test Solution and isothermalize again for 10 minutes in a 40°C water bath. Control Solution is Enzyme Blank Test Solution and the absorbance is measured with 1cm of its liquid layer at 412nm. The enzyme activity is calculated following the formula.

$$\beta\text{-Glycosidase(U/g)} = \frac{(S_A - B_A) \times V}{f \times 10} \times \frac{1}{w}$$

S_A : Absorbance of Enzyme Test Solution

B_A : Absorbance of Enzyme Blank Test Solution

V : The amount of final reaction solution(mL)

f : Absorbance coefficient measured with standard 4-nitrophenol solution

t: Reaction time(minutes)

w : Weight of sample(g) contained final reaction solution

Definition of Activity : 1 β -Glycosidase unit corresponds to the amount of enzyme, which isolated from 1 μ mol of p-nitrophenol per minute under the above test conditions

Solutions

20mM acetic acid solution : 1.6g of sodium acetic acid(anhydrous) dissolve in water to make 1,000 mL volume

20mM acetic acid solution : 1.2 g of actic acid solution dissolvee in water to make 1,000 mL volume

20mM acetic acid buffer solution(pH 5.5) : Stir continually 20mM acetic acid solution and add 20mM acetic acid solution to adjust to pH 5.5

20mM substrate solution: 43.34mg of 4-Nitrophenyl-primeveroside(MW=433.4) dissolve in 20mM acetic acid buffer solution, and make 50mL volume.

0.5M sodium carbonate solution : 5.3g of sodium carbonate dissolve and made up 100mL.

Standard 4-Nitrophenol solution : 4-nitrophenol is dried advance. 139.0 mg of 4-nitrophenol is precisely weighted, and dissolved in 20mM acetic acid buffer solution to make 100mL. 1mL of this solution should contain 100 μ mol of nitrophenol. Dilute with 20mM acetic acid buffer solution to contain each 40, 80, 120, 160 and 200 μ mol per 1mL of this solution. 8 mL of 4-Nitrophenol solution of each concentrate is added to each test tube(five test tubes). Isothermalize for 5 minutes in a 40°C water bath. Add 10mL of 0.5M sodium carbonate solution, and mix. Water is used as reference solution. Absorbance is measured by 1cm of the liquid layer at 412nm, and the curve based on the amount of p-nitrophenol is prepared. the curve should be passed zero point and straight line. The average absorbance coefficient(f) of diluted solution is calculated to divide the absorbance of each diluted solution into the concentrate of p-nitrophenol(μ mol/mL), and the absorbance is measured.

Stotage standard of β -Glycosidase

β -Glycosidase should be stored in a hermetic container in a cold dark place.

Gold Leaf

INS No.: 175

Synonyms: Pigment metal 3; Aurum

CAS No.: 7440-57-5

Definition Gold Leaf is a thin sheet of gold.

Compositional Specifications of Gold Leaf

Content Gold Leaf should contain no less than 94.4% of gold (Au).

Description Gold Leaf is yellow extremely thin and soft sheet.

Identification (1) Gold Leaf is insoluble in hydrochloric acid, nitric acid, and sulfuric acid but soluble in aqua Regia.

(2) 0.01 g of Gold Leaf dissolve in 5 mL mixed solution of nitric acid : hydrochloric acid : water (1 : 4 : 5) by heating. Cool the solution, 2 mL of hydrochloric acid is added to this solution, which is then concentrated by heating in a water bath. This process is repeated 4 times to remove nitric acid. 20 mL of water is added to the resulting residue, where sodium hydroxide solution is added to adjust the acidity to slightly acid. When 1 mL of 5-(p-dimethylamino- benzylidene)rhodanine solution in ethyl alcohol (1→3,000) to the resulting solution, it shows reddish violet in color.

Purity (1) Arsenic : It should be no more than 5.0 ppm tested by Arsenic Limit Test.

(2) Copper : Weight 0.2 g of Gold Leaf and add aqua regia to dissolve Gold Leaf by heating. If the precipitate of silver chloride are produced, add hydrochloric acid until the precipitate is completely dissolved. After cooling, add hydrochloric acid to make 10 mL (Test solution). When the test solution is carried by Atomic Absorption Spectrophotometry or Inductively Coupled Plasma Emission Spectroscopy, its content should not be more than 50 ppm.

Aqua regia : Mix hydrochloric acid and nitric acid in the proportion of 3:1. Prepare Aqua regia when using it.

Assay 20 mL of dilute nitric acid (1→2) is added to precisely weighted 0.5 g of Gold Leaf, which is heated for 10 minutes at 50°C or lower. It is then thermally decomposed with 30 mL of aqua Regina, where water is added to bring the total volume to exactly 100 mL. 3 mL of the resulting solution is diluted to 200 mL with water. 5 mL of this solution is further diluted to 100 mL (Test Solution). Separately, 5 mL of gold standard solution (1 mL = 1,000 µg Au) for atomic absorption spectrophotometer is diluted to 50 mL with water. 2, 4, 6, 8, and 10 mL each of this solution is further diluted to 100 mL with water (Standard Solutions). Test Solution and each Standard Solution are analyzed with atomic absorption spectrophotometer by the following Operation Conditions. The content of gold is obtained from a calibration curve prepared from Standard Solutions.

Operation Conditions

- Gas : flammable gas : acetylene or hydrogen
Retarding gas : air
- Lamp : Gold, hollow cathode lamp
- Wavelength : 242.8 nm

Grape Juice Color

Definition Grape Juice Color is a pigment obtained after removing precipitates from juice extracts of grapes (*Vitis labrusca* Linné or *Vitis vinifera* Linné) of vitaceae. Its major pigment component is malvidin-3-glycoside. Dilutant, stabilizer, or solvent can be added for the purpose of color value adjustment and quality preservation.

Compositional Specifications of Grape Juice Color

Content Color value ($E_{1cm}^{10\%}$) of Grape Juice Color should not be less than the labelled value.

Description Grape Juice Color is dark red liquid, paste, powder, or paste with a slight characteristic scent.

Identification (1) A solution of Grape Juice Color in citrate buffer solution (pH 3.0, 1→100) is red in color and has a maximum absorption band near 525 nm.

(2) When the solution in (1) is alkalinized with sodium hydroxide solution (1→25), its color changes to dark green.

Purity (1) Arsenic : It should be no more than 4.0 ppm tested by Arsenic Limit Test.

(2) Lead : When 5.0 g of Grape Juice Color is tested by Atomic Absorption Spectrophotometry or Inductively Coupled Plasma Emission Spectroscopy, its content should not be more than 10.0 ppm.

Assay Appropriate amount of Grape Juice Color is precisely weighted so that the absorption is within 0.3 ~ 0.7 and dissolved in citric acid buffer solution (pH 3.0) so that the total volume is 100 mL (Test Solution). If necessary, the solution is centrifuged and the supernatant is used. Using citric acid buffer solution (pH 3.0) as a reference solution, absorption A is measured at the maximum absorption near 525 nm with 1cm path length. Color value is obtained using the following equation.

$$\text{Color Value} (E_{1cm}^{10\%}) = \frac{A \times 10}{\text{Weight of the sample(g)}}$$

• Citric acid buffer solution (pH 3.0)

Solution 1 : 1 l of solution containing 121g of citric acid ($C_6H_8O_7 \cdot H_2O$).

Solution 2 : 1 l of solution containing 71.6 g of dibasic sodium phosphate ($Na_2HPO_4 \cdot 12H_2O$).

Solution 1 and Solution 2 are mixed well (159 : 41) and its pH is adjusted to 3.0.

Grape Skin Extract

Synonyms: Grape skin color; Enociana

INS No.: 163(ii)

Definition Grape Skin Extract is a pigment obtained from skins of grapes (*Vitis labrusca* Linné or *Vitis vinifera* Linné) of vitaceae by water extracting. Its major pigment component is anthocyanin. Dilutant, stabilizer, or solvent can be added for the purpose of color value adjustment and quality preservation.

Compositional Specifications of Grape Skin Extract

Content Color value ($E_{1cm}^{10\%}$) of Grape Skin Extract should not be less than the labelled value.

Description Grape Skin Extract is red ~ dark purple liquid, lump, powder, or paste having a characteristic odor.

Identification (1) Test Solution obtained in Color Value section shows red color and a maximum absorption is at about 525 nm.

(2) When Test Solution in (1) is alkalinized with sodium hydroxide solution, the color of the solution becomes dark green.

Purity (1) Arsenic : It should not be more than 4.0 ppm tested by Arsenic Limit Test.

(2) Lead : When 5.0 g of Grape Skin Extract is tested by Atomic Absorption Spectrophotometry or Inductively Coupled Plasma Emission Spectroscopy, its content should not be more than 2.0 ppm.

(3) Sulfur Dioxide : Approximately 1 g of Grape Skin Extract is precisely weighed into a distillation flask with the Wagner Tube as shown in the figure below. It is then refluxed in 100 mL of water and 25 mL of phosphoric acid (2→7). 25 mL of lead acetate solution (1→50) is placed in the collector. The condenser is arranged so that its lower end is immersed in the lead acetate solution. It is distilled until the liquid in the flask reaches about 100 mL. The end of the condenser is washed with a little amount of water. Washings is added to the distillate, where 5 mL of hydrochloric acid and 1 mL of starch solution. It is then titrated with 0.01 N iodine solution. The content of sulfur dioxide should not be more than 0.005% of 1 Color value ($E_{1cm}^{10\%}$). Separately, a blank test is carried out.

0.01 N iodine solution 1 mL = 0.3203 mg SO₂

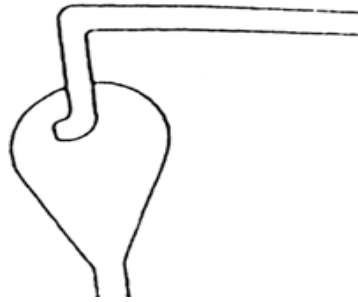

Wagner Tube

Assay (Color Value) An adequate amount of Grape Skin Extract so that the measured absorbance is between 0.3 and 0.7 is accurately weighed and added pH 3.0 citric acid-dibasic sodium phosphate buffer solution to make up a 100 mL solution. 1 mL of this solution is diluted to 100 mL with pH 3.0 citric acid-dibasic sodium phosphate buffer solution, the Test Solution. If necessary, the solution is centrifuged and the supernatant is used. Using pH 3.0 citric acid-dibasic sodium phosphate buffer solution as the blank, absorption A is measured at the wavelength of maximum absorption around 525 nm with 1cm cell. Color value is obtained using the following equation.

$$\text{Color Value} \left(\frac{E_{1\text{cm}}^{10\%}}{\text{cm}} \right) = \frac{A \times 10}{\text{weight of the sample(g)}}$$

◦ Citric acid-dibasic sodium phosphate buffer solution (pH 3.0)

Solution 1 : 0.1 M citric acid solution : 1ℓ of solution containing 21.01 g of citric acid ($\text{C}_6\text{H}_8\text{O}_7 \cdot \text{H}_2\text{O}$).

Solution 2 : 0.2 M dibasic sodium phosphate solution : 1ℓ of solution containing 71.63 g of dibasic sodium phosphate ($\text{Na}_2\text{HPO}_4 \cdot 12\text{H}_2\text{O}$).

Solution 1 and Solution 2 are mixed well (159:41) and its pH is adjusted to 3.0.

Grape Seed Extract

Definition Grape Seed Extract is obtained from the seeds of the grapes (*Vitis labrusca* LINNE, *Vitis vinifera* LINNE) of vitaceae. Its major component is proanthocyanidin.

Compositional Specifications of Grape Seed Extract

Content Grape Seed Extract contains 90 ~ 130% of the labelled as proanthocyanidin.

Description Grape Seed Extract is yellow ~ dark brown powder with slight characteristic scent and slightly bitter taste.

Identification (1) 0.01 g of Grape Seed Extract dissolve in 10 mL of ethyl alcohol solution (10→100). When 1 ~ 2 drops of ferric chloride solution are added to this solution, it shows deep green ~ greenish brown color.

(2) 0.1 g of Grape Seed Extract dissolve in 10 mL of ethyl alcohol solution (10→100). When 1 mL of hydrochloric acid is added to this solution and heated in a water bath, it becomes red in color.

Purity (1) Arsenic : It should not be more than 4.0 ppm tested by Arsenic Limit Test.

(2) Lead : When 5.0 g of Grape Seed Extract is tested by Atomic Absorption Spectrophotometry or Inductively Coupled Plasma Emission Spectroscopy, its content should not be more than 10.0 ppm.

(3) E.coli : When Grape Seed Extract is tested by Microbe Test Methods for E.coli in General Test Method of「Standards and Specifications for Foods」, it should be negative (-).

Loss on Drying When 3 g of Grape Seed Extract is precisely weighted and dried for 3 hours at 105 °C, the weight loss should not be more than 10 %.

Assay Grape Seed Extract is precisely weighted (so that the concentration of proanthocyanidin is 10~50 mg) and dissolved in methyl alcohol (total volume = 100 mL, Test Solution). 0.5 mL of Test Solution is placed in a brown test tube, where 3.0 mL of vanillin solution in methanol (4→100) is added. It is stirred for 10 seconds. After adding exactly 1.5 mL of hydrochloric acid, it is capped immediately and set aside for 15 minutes at 18~22°C. Using water as a reference, absorption at 500 nm is measured. The content of (+) catechin equivalent is obtained from a standard curve. This is the content of proanthocyanidin. To correct for anthocyanidin present in the sample, the same procedure as Test Solution is followed with 3 mL of methanol instead of vanillin solution in methanol. Absorption is measured at 500 nm using water as a reference. This absorption value is subtracted from that of Test Solution. The content of (+) catechin equivalent in test solution is obtained from a standard curve. This is the content of proanthocyanidin.

Standard Curve : Methyl alcohol is added to precisely weighted 100 mg of (+) catechin standard (total volume = 100 mL). 1, 2, 3, 5 mL of this solution is diluted to 10 mL with methyl alcohol (Standard Solutions). 0.5 mL each of Standard Solution is placed in a brown test tube, where 3.0 mL of vanillin solution in methanol (4→100) is added. It is stirred for 10 seconds. After adding exactly 1.5 mL of

hydrochloric acid, it is capped immediately and set aside for 15 minutes at 18~22°C. Using water as a reference, absorption of each Standard Solution at 500nm is measured. A standard curve of absorption vs. concentration of Standard Solution (mg/mL) is prepared. Separately, a blank test is carried out by following the same procedure as Test Solution with 0.5 mL of water instead of catechin standard solution. The content of proanthocyanidin is obtained by the following equation.

$$\text{Content(\%)} = \frac{A}{\text{Weight of the sample(mg)}} \times \frac{\text{dilution rate}}{\text{rate}} \times 100$$

A : Amount of (+) catechin equivalent in Test Solution obtained from the standard curve (mg)

Guar Gum

INS No.: 412

Synonyms: Gum cyamopsis; Guar flour

CAS No.: 9000-30-0

Definition Guar gum is obtained by crushing endosperms of guar (*Cyamopsis tetragonolobus* TAUB.) seed of leguminosae or extracting by warm water, hot water, isopropyl alcohol. The major component is polysaccharides.

Compositional Specifications of Guar Gum

Description Guar gum is white ~ pale yellowish brown powder or particles. It is almost odorless or has a slight odor.

Identification (1) 2 g of Guar gum is placed in a 400 mL beaker and wetted completely with 4 mL isopropyl alcohol. While stirring vigorously, 200 mL of water is added and homogenized. It becomes milky white viscous liquid.

(2) When 100 mL of Test Solution in Identification (1) is boiled for 10 minutes in a water bath and cooled, the viscosity does not increase.

(3) When small amount of borax is added to 100 mL of Test Solution in Identification (1), it forms gel.

Purity (1) Arsenic : It should be no more than 4.0 ppm tested by Arsenic Limit Test.

(2) Lead : When 5.0 g of Guar gum is tested by Atomic Absorption Spectrophotometry or Inductively Coupled Plasma Emission Spectroscopy, its content should not be more than 2.0 ppm.

(3) Cadmium : When 5.0 g of Guar gum is tested by Atomic Absorption Spectrophotometry or Inductively Coupled Plasma Emission Spectroscopy, its content should not be more than 1.0 ppm.

(4) Mercury : When 0.1 g of Guar gum is tested by Mercury Test Method, its content should not be more than 1.0ppm.

(5) Starch : 0.1 g of Guar gum is dissolved in 10 mL of water by boiling for 1 minute, which is then cooled. When 2 drops of iodine solution are added, it should not show blue.

(6) Isopropyl alcohol : 0.2 g of Guar gum is accurately weighed and transferred into a 300 mL round bottom flask, 200 mL of water is added, boiling chips and 1 mL of silicone resin are added and mixed well. Distillation column is connected to this, 4 mL of internal standard solution is accurately weighed and added to a 100 mL flask. While caring for the bubbles not to overflow, distill the solution at the rate of 2~3 mL per 1 minute until the milky liquid becomes about 90 mL, and water is added to make 100 mL, test solution. However, tert-butyl alcohol (1→1,000) is used as internal standard solution. Separately, 0.5 g of isopropyl alcohol is accurately weighed and water is added to make 500 mL, 2 mL of this solution and 4 mL of internal standard solution is weighed again, water is added to make 100

mL, standard solution. 2µl of test solution and standard solution is taken respectively, and injected to gas chromatograph with the following operation condition. Then, ratio of isopropyl alcohol peak against tert-butyl alcohol peak in test Solution and standard solution, QT and QS, is calculated separately, and the content of isopropyl alcohol is calculated by following formula, the content should not be more than 1.0%.

$$\text{Content of Isopropyl alcohol(\%)} = \frac{\text{Weight of isopropyl alcohol(g)}}{\text{Weight of sample(g)}} \times \frac{Q_T}{Q_S} \times \frac{2 \times 100}{500 \times 100} \times 100$$

QT : Ratio of isopropyl alcohol peak against tert-butyl alcohol peak in Test Solution

QS : Ratio of isopropyl alcohol peak against tert-butyl alcohol peak in standard solution

Operation Conditions

Column : PLOT Q or equivalent

Detector : Hydrogen Flame Ionization Detector (FID)

Injection temperature : 200°C

Column Temperature : 120°C

Detector temperature : 300°C

Carrier gas : Nitrogen or Helium

- (7) Borates : 1 g of Guar Gum is accurately weighed and water is added to make 100 mL (Gel should not be formed). When 10 mL of diluted hydrochloric acid is added and mixed and 1 drop of this solution is added to turmeric paper(Advantec 07810074 or its equivalent), it should not turn reddish brown.
- (8) Total Viable Aerobic Count : When Guar Gum is tested by Microbe Test Methods for Total Viable Aerobic Count (Number of General Germs) in General Test Method in 「Standards and Specifications for Foods」, it should not be more than 5,000 CPU per 1 g
- (9) E. Coli : When Guar Gum is tested by Microbe Test Methods for E. Coli in General Test Method 「Standards and Specifications for Foods」, it should be negative (-).
- (10) Salmonella : When Guar Gum is tested by Microbe Test Methods for Salmonella in General Test Method 「Standards and Specifications for Foods」, it should be negative (-).
- (11) Number of Fungi : When Guar Gum is tested by Microbe Test Methods for Number of Fungi in General Test Method in 「Standards and Specifications for Foods」, it should not be more than 500 CFU per 1 g

Acid Insoluble substances 1.5 g of Guar gum is accurately weighed and dissolved it in a beaker containing 150 mL of water and 1.5 mL sulfuric acid, which is covered with a watch glass and heated for 6 hours in a water bath. Occasionally, it is stirred with a glass rod and water is added to supplement the

loss. After heating is complete, it is filtered through a glass filter with constant weight, containing 500 mg of appropriate filtering aid, accurately weighed. The residue is washed thoroughly with hot water and dried for 3 hours at 105°C. The weight of the filtering aid is subtracted from the weight of the residue, which should not be more than 7.0%.

Total Ash When 3 g of Guar gum is accurately weighed and reduced to ash at 600°C, the content should not be more than 1.5%.

Loss on Drying When 3 g of Guar gum is dried for 5 hours at 105°C, the weight loss should not be more than 15%.

Protein When Guar gum is proceeded as directed under Kjeldahl Method in Nitrogen Determination, the amount should not be more than 10%. (Protein Factor : 6.25).

Gum Ghatti

INS No.: 419

Synonyms: Indian gum; Ghatti gum

CAS No.: 9000-28-6

Definition Gum Ghatti is a polysaccharide obtained by drying sap that is leached from stems of *Anogeissus latifolia* WALL. or plants of the same genus.

Compositional Specifications of Gum Ghatti

Description Gum Ghatti is powder or granule with gray ~ reddish gray, or pale brown ~ dark brown amorphous solid. Gum Ghatti is almost scentless.

Identification (1) When 1 g of Gum Ghatti is dissolved in 5 mL of water, it becomes a viscous liquid.
(2) To 5 mL of the filtrate which aqueous solution of Gum Ghatt (1→100) is filtered with diatomite, 0.2 mL of diluted alkaline lead acetate solution(1→5) is added, then precipitate is not formed or slight precipitate is formed. When 0.5 mL of ammonia solution is added to this solution, opaque wool shaped precipitate is formed.
(3) The filtrate which aqueous solution of Gum Ghatt(1→50) is filtered with diatomite is levorotatory.

Purity (1) Arsenic : It should be no more than 4.0 ppm tested by Arsenic Limit Test.
(2) Lead : When 5.0 g of Gum Ghatti is tested by Atomic Absorption Spectrophotometry or Inductively Coupled Plasma Emission Spectroscopy, its content should not be more than 2.0 ppm.
(3) Acid Insoluble Ash : When Gum Ghatti proceed as directed under Ash and Acid-Insoluble Ash Limit, the content should not be more than 1.75 %.
(4) Salmonella : When Gum Ghatti proceed as directed under Microbiological Methods for Salmonella in General Testing Methods in 「Standards and Specifications for Foods」, it should be negative (-).
(5) E. coli : When Gum Ghatti proceed as directed under Microbiological Methods for E. coli in General Testing Methods in 「Standards and Specifications for Foods」, it should be negative (-).

Loss on Drying When Gum Ghatti is dried for 5 hours at 105°C, the weight loss should not be more than 14%.

Ash When Gum Ghatti is tested for ash content, it should not be more than 6%

Heme Iron

Definition Heme Iron is obtained by separating hemoglobin enzymatically. Its component is Heme iron.

Compositional Specifications of Heme Iron

Content Dried Heme Iron contains 9.0~27.0% of protoheme ($C_{34}H_{32}FeN_4O_4 = 616.48$) and 1.0~2.6% of iron ($Fe = 55.85$).

Description Heme Iron is blackish brown powder or granule. It can be scentless or have a slight characteristic scent.

Identification (1) 100 mg of Heme Iron is dissolved in 500 mL of pyridine sodium hydroxide solution. When 15 mg of sodium hyposulfite is added to 5 mL of this solution, it becomes red.

(2) 10 mg of Heme Iron is added to a 100 mL flask for decomposition, where 5 mL of nitric acid is added. When it is heat treated, it becomes yellow. Cool and alkalinize it with ammonia water. The color becomes orange yellow.

Purity (1) Arsenic : It should be no more than 4.0 ppm tested by Arsenic Limit Test.

(2) Lead : When 5.0 g of Heme Iron is tested by Atomic Absorption Spectrophotometry or Inductively Coupled Plasma Emission Spectroscopy, its content should not be more than 2.0 ppm.

Loss on Drying When Heme Iron is dried for 3 hours at 105°C, the weight loss should not be more than 6%.

Residue on Ignition When thermogravimetric analysis is done with precisely weighted 2 g of Heme Iron, the amount of Residue on Ignition should not be more than 8%.

Assay (1) Protoheme : 100 mg of Heme Iron is precisely weighted into a 250 mL flask and dissolved in pyridine sodium hydroxide solution so that the total volume is exactly 250 mL (Test Solution). 1 mL of Test Solution is accurately sodium hyposulfite transferred into a test tube, where 2 mL of pyridine sodium hydroxide solution is added and 3 mg of sodium hyposulfite is added immediately. Absorption of the resulting solution is measured at 557 nm using pyridine sodium hydroxide solution as a reference. Separately, 1 mL of each hematin Standard Solution is added to a test tube, where 2 mL of pyridine sodium hydroxide solution is added and 3 mg of sodium hyposulfite is added immediately. Absorption of each solution is measured by following the same procedure as Test Solution and a calibration curve is prepared. The content of protoheme is obtained from the calibration curve and the absorption of Test Solution.

(2) Iron : 20~50 mg of this additive is precisely weighted into a 100 mL flask for decomposition, where 5 ~ 10 mL of nitric acid is added. It is gently heated until the evolution brown nitrogen oxide gas subsides. Cool the flask to room temperature, add 2 mL of perchloric acid to the flask, which is heated gently and then strongly until the solution becomes colorless and white smoke subsides. Cool and transfer the reaction mixture into a flask(Recovery). The flask for decomposition is washed with water, which is added to this flask. pH of the solution is adjusted to 3 ~ 8 with ammonia solution. Dilute the resulting solution to exactly 100 mL with water (Test Solution). 10 mL of Test Solution is added to a 100 mL flask and

diluted to approximately 50 mL with water. To this solution, 1 mL of hydroxylamine hydrochloride solution (1→4), 5 mL of o-phenanthroline solution in hydrochloric acid (0.12→100), and 20 mL of acetate buffer solution (pH 4.2) are added. The total volume is brought up to 100 mL with water. Set it aside for 1 hour at room temperature, measure absorption at 510nm. Separately, 0.5, 1, 5, 10, 20 mL each of iron standard solution is placed in 100 mL flask, where 3 mL hydrochloric acid (1→4) and water are added to bring the total volume to approximately 50 mL. The same procedure as Test Solution is followed with these standard solutions. Absorption is measured to prepare a calibration curve. The content of iron is obtained from the calibration curve and the absorption of the Test Solution.

Solutions

- Pyridine Sodium Hydroxide Solution : 100 mL of pyridine and 30 mL of 1 N sodium hydroxide solution are mixed and the total volume is brought up to exactly 300 mL with water.
- Acetate Buffer Solution (pH 4.2) : 250 g of ammonium acetate is dissolved in 120 mL of water and 700 mL of acetic acid. The solution is diluted with water to 1,000 mL.
- Hematin Standard Solution : Hematin is dried for 3 hours at 100°C. 100 mg is precisely weighed and dissolved in pyridine sodium hydroxide solution so that the total volume is exactly 100 mL (hematin standard solution, undiluted). 1, 5, 10, and 20 mL each of undiluted standard solution is diluted to 100 mL with pyridine sodium hydroxide solution. It is further diluted so that 1 mL of the final dilution contains 1, 5, 10, and 20 µg of hematin (Hematin Standard Solution).
- Iron Standard Solution (for heme iron) : 7.0213 g of ferrous ammonium sulfate ($\text{Fe}(\text{NH}_4)_2(\text{SO}_4)_2 \cdot 6\text{H}_2\text{O}$) is precisely weighed and dissolved in a small amount of water. 3 mL of dilute hydrochloric acid (1→4) and water are added to bring the total volume to exactly 1,000 mL (Iron Standard Solution). From this solution, 10 mL is taken and made 100 mL by adding water. This is the standard solution (1 mL of this solution contains 100 µg of Fe).

Hemicellulase

Definition Hemicellulase is an enzyme obtained from cultures of *Aspergillus niger* and its variety. Diluent or stabilizer can be added for the purpose of activity adjustment and quality preservation.

Compositional Specifications of Hemicellulase

Description Hemicellulase is white ~ dark brown powder, particle, paste or colorless ~ dark brown liquid.

Identification When Hemicellulase is proceeded as directed under Activity Test, it should have the activity as Hemicellulase.

Purity (1) Arsenic : It should be no more than 4.0 ppm tested by Arsenic Limit Test.

(2) Lead : When 5.0 g of Hemicellulase is tested by Atomic Absorption Spectrophotometry or Inductively Coupled Plasma Emission Spectroscopy, its content should not be more than 5.0 ppm.

(3) Coliform Group : When Hemicellulase proceed as directed under Microbiological Methods for Coliform Group in General Testing Methods in 「Standards and Specifications for Foods」, it should not contain more than 30 per 1 g of this product.

(4) Salmonella : When Hemicellulase proceed as directed under Microbiological Methods for Salmonella in General Testing Methods in 「Standards and Specifications for Foods」, it should be negative (-).

(5) E. Coli : When Hemicellulase is tested by Microbe Test Methods for E. Coli in General Test Method 「Standards and Specifications for Foods」, it should be negative (-).

Activity Test (Activity)

- Application and Principle : Activity test is based on enzymatic hydrolysis of Glycosidic bonding within locust bean gum substrate at pH 4.5, 40°C temperature. The decrease in viscosity of the substrate is measured by a viscometer with its scale corrected.
- Preparation of Test Solution : Test Solution is prepared by dilution so that 1 mL of the final solution shows variation in relative fluidity of 0.18 ~ 0.22 under the conditions below in 5 minutes. Certain amount of sample is ground in a glass mortar and water is added. It is diluted in a suitable volumetric flask. Filter the solution through a Whatman No.1 filter paper or its equivalent prior to use.
- Test Procedure : A viscometer (scale is previously corrected) is cleanly washed in water with sufficient detergent. It is then set up vertically in a glass water bath at $40 \pm 0.1^\circ\text{C}$. 20 mL of substrate solution and 4 mL of acetate buffer solution are added into a 50 mL Erlenmeyer flask with a stopper. Prepare 2 for enzyme test and 1 for substrate blank test per sample. An enzyme test flask is plugged with a stopper and isothermalized for 15 minutes in a water bath, where accurately 1 mL of Test Solution is added and well mixed measuring the time. Immediately, 10 mL of the mixed solution is added to the big branch of the viscometer. Approximately in 2 minutes, the reaction mixture is sucked in through the thin branch of the viscometer up to the upper scale using a rubber bulb. Time taken to reach the upper scale is measured in minutes (T_R). Again time taken to reach the lower scale (starting from the upper scale) is measured in seconds (T_T). By repeating the same procedure, T_R and T_T are measured again. This is

repeated 4 times. Separately, a mixture of 20 mL substrate solution, 4 mL acetate buffer solution and 1 mL water is added to the big branch of the viscometer. The time taken to reach the lower scale from the upper scale is measured five times and an average value is obtained T_S (seconds). A blank water test is carried out with 10 mL of water that is isothermalized at $40 \pm 0.1^\circ\text{C}$ by following the same procedure. An average value of 5 measurements is obtained, T_W (seconds). Using the following equation, relative fluidity and T_N values are obtained for each of 4 measurements of effluent time (T_T) and reaction time (T_R).

$$F_R = \frac{T_S - T_W}{T_T - T_W}$$

$$T_N = \frac{1}{2} \left(\frac{T_T}{60} \text{ sec/m} + \frac{T_R}{2} \right) = 1 \text{ } T_R$$

F_R : Relative fluidity for each reaction time

T_S : Average effluent time for blank substrate test (seconds)

T_W : Average effluent time for blank water test (seconds)

T_T : Effluent time for enzyme reaction solution (seconds)

T_R : Reaction time (minutes) (time taken from "adding the Test Solution" to "before the measurement of effluent time (T_T)")

T_N : Reaction time (T_R) (minutes) + one half of effluent time for Test Solution (T_T) (minutes)

$$\text{HCU/g} = \frac{1,000(F_{R10} - F_{R5})}{W}$$

A standard curve is prepared using the 4 relative fluidity (F_R) values for the 4 reaction times (T_N). This should be a straight line. The slope corresponds to the change in relative fluidity per minute and is proportional to the amount of enzyme. The optimum slope of a series of measurements is a better basis for the enzyme activity than a single value of relative fluidity. F_R values at 10 and 5 minutes are measured from the standard curve. The difference in fluidity should be 0.18 ~ 0.22. The enzyme activity is obtained from the following equation.

F_{R10} : Relative fluidity at reaction time of 10 minutes

F_{R5} : Relative fluidity at reaction time of 5 minutes

1,000 : Conversion activity (g to mg)

W : Weight of sample in 1 mL of Test Solution (mg)

Definition of Activity : 1 hemicellulase unit (HCU) is the activity which generate a change of 1 in relative fluidity for 5 minutes under the above test conditions within a locust bean gum substrate.

Apparatus

- Viscometer : Cannon Fenske Type Viscometer with size 100 corrected scale or its equivalent.
- Glass water bath : Isothermal glass water bath at $40 \pm 0.1^\circ\text{C}$ or its equivalent.

Agents and Solutions

- Acetate Buffer Solution (pH 4.5) : pH of 400 mL of 0.2 N acetic acid is adjusted to 4.5 ± 0.05 by adding 0.2 N of sodium acetate solution while stirring continuously.
- Locust Bean Gum : Quality of powdered locust bean gum varies with substrate lots. Therefore, when a different lot is used, its quality should be checked. If each viscosity difference is more than $\pm 5\%$, it cannot be used for the same test.
- Substrate Solution : 12.5 mL of 0.2 N hydrochloric acid and 250 mL of warm water ($70 \sim 75^\circ\text{C}$) are added in a mixing container and the mixer is set at a low speed. 2 g of dried locust bean gum is carefully added so that it does not splash, and scatter in the container slowly. Using a rubber police, container wall is scraped down with warm water. The container is then covered and the solution is mixed for 5 minutes at a high speed. It is then transferred into a 1,000 mL beaker and cooled to normal temperature. pH of the solution is adjusted to 6.0 with 0.2 N sodium hydroxide solution. Transfer the resulting solution into a 1,000 mL volumetric flask and diluted to 1,000 mL with water. It is filtered through a gauze before use.

Storage Standards of Hemicellulase

Hemicellulase is strongly hygroscopic. Store in a cold dark place and well-closed containers.

Hesperidin

Definition Hesperidin is obtained by purifying the extracts of peels, juices, or seeds of tangerine (*Citrus paradisi* MACF.) of rutaceae with water, ethyl alcohol or organic solvents. Its component is hesperidin.

Compositional Specifications of Hesperidin

Content When Hesperidin is dried, it should contain no less than 95.0% of hesperidin ($C_{28}H_{34}O_{15}$ = 610.57).

Description Hesperidin is almost scentless and tasteless white ~ pale yellow crystallite or crystalline powder.

Identification (1) When Hesperidin is dissolved in sodium hydroxide solution (1→20) or heated anhydrous sodium carbonate solution (1→100), it is orange yellow ~ reddish yellow in color.

(2) 5 mL of ethyl alcohol and 1 mL of sodium hydroxide solution (1→20) are added to 0.1 g of Hesperidin. When the mixture is boiled for 2 ~ 3 minutes and cooled, the filtrate is yellow in color.

(3) 5 mL of ethyl alcohol is added to 0.1 g of Hesperidin, which is heated, cooled, and filtered. When 1 mL of hydrochloric acid and 0.01g of magnesium powder are added to 4 mL of the filtrate, the liquid shows red in color.

(4) 10 mL of hydrochloric acid (1→9) is added to 0.1 g of Hesperidin, which is boiled for 5 minutes. Cool the solution, it is filtered. The filtrate is neutralized with sodium hydroxide solution (1→4). When 3 mL of Fehling solution is added to the resulting solution, red precipitates are formed.

Purity (1) Clarity of Solution : A solution of 1 g of Hesperidin in 10 mL of sodium hydroxide solution (4.3→100) should be orange yellow ~ yellowish brown and almost clear (or less).

(2) Arsenic : It should be no more than 4.0 ppm tested by Arsenic Limit Test.

(3) Lead : When 5.0 g of Hesperidin is tested by Atomic Absorption Spectrophotometry or Inductively Coupled Plasma Emission Spectroscopy, its content should not be more than 10.0 ppm.

Loss on Drying When 1 g of Hesperidin is dried for 3 hours at 105°C, the weight loss should not be more than 5%.

Residue on Ignition When thermogravimetric analysis is done with 1 g of Hesperidin, the amount of residue should not be more than 0.3%.

Assay After drying for 3 hours at 105°C, 50 mg of Hesperidin is precisely weighted and dissolved in 0.01 N sodium hydroxide solution (total volume = 100 mL). 2 mL of this solution is diluted to 50 mL with 0.01 N potassium hydroxide solution (Test Solution). Absorption A of the Test Solution is measured at 286 nm and the content (%) of Hesperidin is obtained from the following equation.

$$\text{Content of hesperidin } (C_{28}H_{34}O_{15})(\%) = \frac{A}{251.7} \times \frac{25,000}{\text{Weight of the sample(mg)}} \times 100$$

Hexane

Chemical Formula: C₆H₁₄

Molecular Weight: 86.18

Synonyms: Mixed paraffinic hydrocarbons

CAS No.: 110-54-3

Definition Hexane is obtained near the boiling point of n-hexane, which is petroleum ingredient, by distillation.

Compositional Specifications of Hexane

Description Hexane is colorless, transparent, volatile liquid with a characteristic scent.

Purity (1) Specific Gravity : Specific gravity of Hexane should be 0.665~0.687.

(2) Refractive Index : Refractive Index n_D^{20} of Hexane should be 1.374~1.386.

(3) Sulfur Compounds : 5 mL of Hexane and 5 mL of silver nitrate ammonia solution are well mixed by shaking. When the mixture heated for 5 minutes at 60°C in protected from light, it should not becomes brown.

(4) Readily carbonizable substances : 5 mL of Hexane is mixed with 5 mL of 94.5~95.5% sulfuric acid by shaking vigorously in a Nestler tube. The color of the sulfuric acid phase should not be deeper than that of the color standard solution B.

(5) Benzene : 50 mL of Hexane is mixed with 50 mL of internal standard solution, and use it as the Test Solution. Separately, 50 mL of benzene standard solution is mixed with 50 mL of internal standard solution, and use it as the Standard Solution. When these solutions are analyzed with gas chromatography, H/Hs should not be greater than H'/Hs', where H, Hs, H', and Hs' are indicated peak heights of Test Solution, internal standard (mixed with Test Solution), Standard Solution, and internal standard (mixed with Standard Solution), respectively. Internal standard solution is prepared by diluting 0.5 mL of methyl isobutyl ketone to 100 mL with n-hexane (UV absorption spectrum measurement grade). Benzene standard solution is prepared by diluting 0.05 mL to 100 mL with n-hexane (UV absorption spectrum measurement grade).

Operation Conditions

-Column : A glass or stainless tube with inner diameter of 3 ~ 4 mm and length of 2 ~ 3 m

-Column Filler : 177~250 μ porous support material. It is treated with chloroform solution that contains polyethylene glycol 6,000 of 10% in weight of the support material. After removing chloroform, it is dried for use

-Column Temperature : a constant temperature in a range of 50 ~ 70°C

-Detector : Flame Ionization Detector (FID)

-Carrier gas and flow rate : Nitrogen, Flow rate is adjusted so that benzene is detected in approximately

5 minutes.

- (6) Distillation Test : When Hexane proceed as directed under Method 2 in Boiling Point and Amount of Distillate, 95% or more should be extracted at 64~70°C.
- (7) Residue on Evaporation : 150 mL of Hexane is carefully evaporated by heating in a water bath. When the residue is dried for 30 minutes at 105°C, it's amount should not be more than 2 mg.
- (8) Lead : When 5.0 g of Hexane is tested by Atomic Absorption Spectrophotometry or Inductively Coupled Plasma Emission Spectroscopy, its content should not be more than 1.0 ppm.
- (9) Polycyclic aromatic hydrocarbons : 25 mL of Polycyclic aromatic hydrocarbons is taken and transferred into a 125 mL separatory funnel. Add 25 mL of n-hexane and well mixed by shaking. 5 mL of dimethyl sulfoxide is added to the solution, which is mixed by shaking vigorously for 1 minute and settled until the phase is separated. Transfer the lower phase into a separatory funnel, where 2 mL of n-hexane is added, shaken vigorously for 2 minutes, and settled until the phase is separated. The lower phase is taken and used it as test solution. 5 mL of dimethyl sulfoxide and 25 mL of hexane are weighted, respectively. Shake and mix for 1 minutes, set aside, and the low phase is used as blank test solution. Absorption of the Test Solution is measured in a wavelength range of 260 ~ 420nm. Separately, 7.0 mg of naphthalene is accurately weighted. Dissolve in 1,000 mL of isooctane, then this solution is blank test solution. Absorption of the reference Solution is measured at 275nm wavelength. When the absorption of test solution is measured at a wavelength range of 260 ~ 420nm, the absorption should not exceed 1/3 of absorption of reference solution measured at 275 nm wavelength.

Hibiscus Color

Definition Hibiscus Color is a pigment obtained by extracting flowers of rose of Sharon (*Hibiscus sabdariffa* Linné) of malvaceae with water. Its major pigment component is delphinidin-3-sambubioside. Dilutant, stabilizer, or solvent can be added for the purpose of color value adjustment and quality preservation.

Compositional Specifications of Hibiscus Color

Content Color value ($E_{1cm}^{10\%}$) of Hibiscus Color should be more than the indicated value.

Description Hibiscus Color is dark red liquid, powder or paste with a slight characteristic scent.

Identification (1) A solution (1→100) of Hibiscus Color in citric acid buffer solution (pH 3.0) is red in color and has a maximum absorption band near 520 nm.

(2) When the solution in (1) is alkalinized with sodium hydroxide solution (1→25), its color becomes dark green.

Purity (1) Arsenic : It should be no more than 4.0 ppm tested by Arsenic Limit Test.

(2) Lead : When 5.0 g of Hibiscus Color is tested by Atomic Absorption Spectrophotometry or Inductively Coupled Plasma Emission Spectroscopy, its content should not be more than 10.0 ppm.

Assay (Color Value) Appropriate amount of Hibiscus Color is precisely weighted so that the absorption is within 0.3 ~ 0.7 and dissolved citrate buffer solution with pH 3.0 so that the total volume is 100 mL (Test Solution). If necessary, the solution is centrifuged and the supernatant is used. Using citrate buffer solution with pH 3.0 as a reference solution, absorption A is measured at 520 nm wavelength with 1cm path length. Color value is obtained using the following equation.

$$\text{Color Value } (E_{1cm}^{10\%}) = \frac{A \times 10}{\text{weight of the sample(g)}}$$

• Citrate buffer solution (pH 3.0)

Solution 1 : 1ℓ of solution containing 121 g of citric acid ($C_6H_8O_7 \cdot H_2O$).

Solution 2 : 1ℓ of solution containing 71.6 g of dibasic sodium phosphate ($Na_2HPO_4 \cdot 12H_2O$).

Solution 1 and Solution 2 are mixed well (159:41) and its pH is adjusted to 3.0.

L-Histidine



Chemical Formula: $C_6H_9N_3O_2$

Molecular Weight: 155.16

CAS No.: 71-00-1

Compositional Specifications of L-Histidine

Content L-Histidine, when calculated on the dried basis, should contain within a range of 98.5~101.5% of L-histidine ($C_6H_9N_3O_2$).

Description L-Histidine is scentless white crystallite or crystalline powder with a slightly bitter taste.

Identification When 2 mL of bromine solution is added to 5 mL of an aqueous solution (1→100) of L-Histidine, the color of the solution turns yellow. Upon heating gently, the solution becomes colorless then reddish brown. Finally, dark gray precipitates are formed.

Purity (1) Specific Rotation : 11 g of pre-dried material is precisely weighed and dissolved in 6 N hydrochloric acid so that the total volume becomes 100 mL. The polarity of this solution should be within a range of $[\alpha]_D^{20} = +12.0 \sim +14.0^\circ$

(2) Lead : When 5.0 g of L-Histidine is tested by Atomic Absorption Spectrophotometry or Inductively Coupled Plasma Emission Spectroscopy, its content should not be more than 5 ppm.

(3) Arsenic : It should be no more than 4.0 ppm tested by Arsenic Limit Test.

(4) Chloride: When 0.07 g of L-Histidine is tested by Chloride Limit Test, its content should not be more than the amount that corresponds to 0.2 mL of 0.01 N hydrochloric acid.(Not be more than 0.1%)

Loss on Drying When L-Histidine is dried for 3 hours at 105°C, the loss should not be more than 0.2%.

Residue on Ignition Residue on ignition of L-Histidine should not be more than 0.2%.

Assay Dissolve about 0.15 g of L-histidine, previously dried and accurately weighed in 3 mL of formic acid and 50 mL of glacial acetic acid. This solution is titrated with 0.1 N perchloric acid solution (indicator : 2 drops of crystal violet solution in glacial acetic acid). At the end point, the color of the solution turns from purple to blue. Separately, a blank experiment is done following the same procedure.

1 mL of 0.1 N perchloric acid solution = 15.52 mg $C_6H_{13}NO_2$

L-Histidine Monohydrochloride



Chemical Formula: $C_6H_9O_2N_3 \cdot HCl \cdot H_2O$

Molecular Weight: 209.64

CAS No.: 5934-29-2

Compositional Specifications of L-Histidine Monohydrochloride

Content L-Histidine Monohydrochloride, when calculated on the dried basis, should contain within a range of 98.0 ~ 101.0% of L-histidine monohydrochloride ($C_6H_9O_2N_3 \cdot HCl \cdot H_2O$).

Description L-Histidine Monohydrochloride occurs as white crystals or crystalline powder. It is odorless and has a bitter and slightly acid taste.

Identification (1) Make L-Histidine Monohydrochloride solution (1→10) alkaline with sodium hydroxide solution(1→4). The solution is levorotatory. Acidify with hydrochloric acid. It turns dextrorotatory.

(2) To 5 mL of L-Histidine Monohydrochloride solution (1→1,000), add 1 mL of ninhydrin solution (1→1,000), and heat for 3 minutes. A purple color develops.

(3) L-Histidine Monohydrochloride responds to the test by Chloride Limit Test (2) in Identification.

(4) To 5 mL of L-Histidine Monohydrochloride solution (1→100), add 2 mL of bromine solution. The color of the solution changes to yellow. Heat gently. The solution becomes colorless, then changes to red-brown in color, and finally a blackish precipitate is formed.

Purity (1) Clarity and Color of Solution : When 1 g of L-Histidine Monohydrochloride is dissolved in 10 mL of water, the solution should be colorless and should not be more than almost clear.

(2) pH : pH of L-Histidine Monohydrochloride solution (1→10) should be within a range of 3.5 ~ 4.5.

(3) Specific Rotation : Approximately 5.5 g, previously dried for 3 hours at 98 ~ 100°C and precisely weighed, is dissolved in 6 N hydrochloric acid to make 50 mL. Optical rotation of this solution should be within a range of $[\alpha]_D^{20} = +8.5 \sim +10.5^\circ$.

(4) Arsenic : It should be no more than 4.0 ppm tested by Arsenic Limit Test.

(5) Lead : When 5.0 g of L-Histidine Monohydrochloride is tested by Atomic Absorption Spectrophotometry or Inductively Coupled Plasma Emission Spectroscopy, its content should not be more than 5.0 ppm.

Loss on Drying When L-Histidine Monohydrochloride is dried for 3 hours at 98 ~ 100°C, the weight loss should not be more than 0.3%.

Residue on Ignition When thermogravimetric analysis is done with L-Histidine Monohydrochloride, the

residue should not be more than 0.1%.

Assay Accurately weigh about 0.2 g of L-Histidine Monohydrochloride, previously dried, and test by Assay for 「L-lysine Monohydrochloride」.

1 mL of 0.1 N perchloric acid = 10.48 mg of $C_6H_9O_2N_3.HCl.H_2O$

Hyaluronic Acid

Definition Hyaluronic Acid is obtained by culturing and refining a cockscomb or *Streptococcus zooepidemicus*, its component is Hyaluronic acid which has bonding structure of N- acetylglucosamine and D-glucuronic acid.

Compositional Specifications of Hyaluronic Acid

Content When hyaluronic acid is converted to a dehydrated form, it contains more than 90 % of hyaluronic acid.

Description Hyaluronic acid is hygroscopic white~pale yellow powder or granules with slightly characteristic odor.

Identification (1) 0.1 g of hyaluronic acid dissolve in 100 mL of water, 10 mL of the solution is accurately taken into a test tube, and 2~3 drops of cetylpyridinium chloride solution(1→20) are added, then white suspension or precipitates are formed.

(2) 0.1 g of hyaluronic acid dissolve in 100 mL of water, 1 mL of the solution is accurately taken into a test tube, and 6 mL of sulfuric acid is added. It is heated in a water bath for 10 minutes, cooled, 0.2 mL of carbazole-ethanol TS is added, and allow to stand, the solution becomes red~reddish violet.

Purity (1) Acidity : 100 mL of water is added to 0.1 g of hyaluronic acid, shaken well and dissolved, then the pH of the solution should be 2.5 ~ 3.5.

(2) Arsenic : It should be no more than 2.0 ppm tested by Arsenic Limit Test.

(3) Lead : When 5.0 g of hyaluronic acid is tested by Atomic Absorption Spectrophotometry or Inductively Coupled Plasma Emission Spectroscopy, its content should not be more than 2.0 ppm.

(4) Other acidic mucopolysaccharides : 20 mg of hyaluronic acid is taken, 20 mL of 1N hydrochloric acid is added, and boiled for 30 minutes in a water bath and cooled. 5 mL of this solution is pipetted, 1.0 mL of 1N barium chloride solution is added, and allow to stand for 15 minutes, then the turbidity should increase not more than reference solution. Here, 1 mL of water is added and used as reference solution instead of 1N barium chloride solution.

(5) Total Viable Aerobic Count : When Hyaluronic acid is tested by Microbe Test Methods for Total Viable Aerobic Count (Number of General Germs) in General Test Method in 「Standards and Specifications for Foods」, it should not be more than 1,000 per 1 g.

(6) E. Coli : When 25 g of Hyaluronic acid is tested by Microbe Test Methods for *E. Coli* in General Test Method 「Standards and Specifications for Foods」, it should be negative (-).

Loss on Drying When 1 g of hyaluronic acid is dried for 4 hours at 105°C, the weight loss should not be more than 10%.

Residue on Ignition When Residue on Ignition analysis is done with accurately weighted 1 g of hyaluronic acid, the content of residue should not be more than 5%.

Assay 0.1 g of hyaluronic acid precisely dried, is accurately weighted, sodium chloride TS is added, shaken well for 3 hours, and mixed to make exactly 100 mL. 5 mL of this solution is accurately taken and sodium

chloride TS is added to make exactly 100 mL, test solution. Separately, about 0.1 g of glucuronolactone is accurately weighted, sodium chloride TS is added, and dissolved to make exactly 100 mL. 3 mL of this solution is taken, sodium chloride TS is added to make exactly 100 mL, glucuronolactone standard solution. Pipette 5 mL of borax.sulfuric acid solution(0.95→100) into the test tube with stopper and cool down iced water, 1 mL each of test solution and glucuronolactone standard solution is added, maintain the temperature of these solutions become not more than room temperature, first slowly shaken and mixed, and next, vigorously shaken and mixed. Then it is boiled in a boiling water bath for 10 minutes, immediately cool down with ice water to room temperature, 0.2 mL of carbazole-ethanol solution(0.125→100) is added, shaken well and mixed. Again, it is boiled in a boiling water bath for 15 minutes and immediately cool down with ice water to room temperature. The solution, which is prepared with 1 mL of sodium chloride solution in the same manner above, is used as reference solution. The absorbance AT and AS of test solution and glucuronolactone standard solution at a 530nm wavelength determine and calculate the content of hyaluronic acid with following equation.

$$\text{Content(\%)} = \frac{\text{Content of glucuronolactone(mg)} \times A_T}{\text{Weight of sample(mg)} \times A_S} \times \frac{3}{5} \times 2.148 \times 100$$

$$2.148 = \frac{\text{Molecular weight of hyaluronic acid 1 unit (378.3)}}{\text{Molecular weight of glucuronolactone (176.12)}}$$

A_T : Absorbance of test solution

A_S : Absorbance of glucuronolactone standard solution

3/5 : dilution factor

Hydrochloric Acid

Chemical Formula: HCl

Molecular Weight: 36.46

INS No.: 507

Synonyms: Muriatic acid; Hydrogen chloride

CAS No.: 7647-01-0

Compositional Specifications of Hydrochloric Acid

Content Hydrochloric Acid should contain within a range of 90.0 ~ 120.0% of the declared content of hydrogen chloride (HCl = 36.46).

Description Hydrochloric Acid is a colorless to light yellow liquid having a pungent odor.

Identification (1) Hydrochloric Acid solution (1→100) is strongly acidic.

(2) Hydrochloric Acid responds to test of Chloride in Identification.

Purity (1) Sulfate : To 1 mL of Hydrochloric Acid, add water to make 100 mL. Take 5 mL of this solution, add 20 mL of water, and neutralize with ammonia solution. This solution is tested by Sulfate Limit Test. The amount should be not more than the amount corresponding to 0.5 mL of 0.01 N sulfuric acid.

(2) Arsenic : It should be no more than 2.0 ppm tested by Arsenic Limit Test.

(3) Lead : Accurately weigh 5.0 g of Hydrochloric Acid and add water to make 25 mL, test solution. When the test solution is tested by Atomic Absorption Spectrophotometry or Inductively Coupled Plasma Emission Spectroscopy, its content should not be more than 1.0 ppm.

(4) Mercury : When Hydrochloric Acid is tested by Mercury Limit Test, its content should not be more than 1.0 ppm.

(5) Iron : When 5.0 g of Hydrochloric Acid is precisely weighed and water is added to make 25 mL, test solution. When the test solution is tested by Atomic Absorption Spectrophotometry or Inductively Coupled Plasma Emission Spectroscopy, its content should not be more than 5.0 ppm.

(6) Oxidizing substances : Transfer 1 mL of Hydrochloric Acid into a 30 mL test tube, dilute to 20 mL with freshly boiled and cooled water, and add 1 mL of potassium iodide solution and 1 mL of starch solution. Stopper the test tube and mix thoroughly, test solution. The intensity of any blue colour developed does not exceed that produced in a control prepared similarly but containing 1 mL of 0.001N iodide (instead of potassium iodide solution) and 1 mL of reagent grade concentrated hydrochloric acid (instead of sample) (Not more than 30 ppm as chlorine).

(7) Reducing substances : Transfer 1 mL of Hydrochloric Acid into a 30 mL test tube, dilute to 20 mL with freshly boiled and cooled water, and add 1 mL of potassium iodide solution, 1 mL of starch solution and 2 mL of 0.001N iodide solution. Stopper the test tube and mix thoroughly. The blue colour produced is not discharged by 1 mL of the sample. (Not more than 70 ppm as sulfur dioxide).

(8) Residue on Evaporation : Transfer 10 g of Hydrochloric Acid into a tared glass dish, evaporate to dryness on a steam bath, dry at 105°C for 30 min, cool in a desiccator and weigh. The weight of the residue does not exceed 50 mg (not more than 0.5%).

Residue on Ignition To 100 g of Hydrochloric Acid, add 1 drop of sulfuric acid, and evaporate to dryness in a water bath. It is then heat treated until the weight becomes constant. The amount of residue should not be more than 0.02%.

Assay Transfer 20 mL of water into a flask with a ground-glass stopper, accurately weigh, add about 3 mL of Hydrochloric Acid, and accurately weigh again. Add 25 mL of water, and titrate with 1 N sodium hydroxide (indicator : 3 ~ 5 drops of bromothymol blue solution).

1 mL of 1 N sodium hydroxide = 36.46 mg of HCl

Hydrogen

Chemical Formula: H₂

INS No.: 949

Molecular Weight: 2.00

CAS No.: 1333-74-0

Compositional Specifications of Hydrogen

Content Hydrogen contains no less than 99.9 % (V/V) of indicated activity as hydrogen (H₂)

Description Hydrogen is a colorless, tasteless and scentless gas.

Purity (1) Oxygen : Oxygen analysis of electric chemical type (Galvanic cell) which has the range of detector, 0 ~ 100 μℓ/mL is used in this test. The amount of oxygen in hydrogen gas should be less than 50 ppm when hydrogen gas is passed by operating the oxygen analysis (Galvanic cell).

(2) Carbon monoxide (CO), carbon dioxide (CO₂) and methane (CH₄) : Carbon monoxide (CO), carbon dioxide (CO₂) and methane (CH₄) are purged by using nitrogen gas. The injection amount for appropriate height of the standard gases is adjusted at the chromatograph which is obtained by inserting standard gases (CO, CO₂ and CH₄) verified correct concentration value. Next, standard gases (CO, CO₂ and CH₄) and sample are inserted into gas chromatograph. Then, each peak area should be less than 50 ppm when the peak areas of the sample and standard gases are compared each other.

Operation Condition

Column : Porapak Q or its equivalent

Detector : Flame Ionization Detector (FID)

Thermal Conductivity Detector (TCD)

The amount of injection : Loop injection (1 ~ 2 mL)

Temperature of injection inlet : 120°C

Temperature of detector : 250°C

Temperature of column : Held at 35°C for 3 minutes and temperature is raised to 250°C at a rate of 35°C per minute.

Temperature of methanizer : 375°C

Carrier gas and flow rate : helium of more than 99.9995% and 25 ~ 30 mL per minute

Assay The content of hydrogen gas is calculated by one point standard quantity of the peak area (or height) obtained from chromatogram by inserting sample and standard gas verified (99.9% and more than) to gas chromatograph with the following operation condition.

Operating Condition

Column : Molecular sieve or its equivalent

Detector : Thermal Conductivity Detector(TCD)

The amount of injection : Loop injection (1 ~ 2 mL)

Temperature of injection inlet : 120°C

Temperature of detector : 250°C

Temperature of column : Temperature is raised from 50°C to 250°C at a rate of 50°Cper minute.

Carrier gas and flow rate : Argon and nitrogen and 25 ~ 30 mL per minute

Hydrogen Peroxide

Chemical Formula: H_2O_2

Molecular Weight: 34.01

Synonyms: Dihydrogen dioxide

CAS No.: 7722-84-1

Compositional Specifications of Hydrogen Peroxide

Content Hydrogen Peroxide should contain 30.0%~50.0% of hydrogen peroxide ($\text{H}_2\text{O}_2= 34.01$).

Description Hydrogen Peroxide is a colorless, clear liquid. It is odorless or has a slight odor.

Identification (1) Hydrogen Peroxide is acidic.

(2) When 5 mL of dilute sulfuric acid and 1 mL of potassium permanganate solution are added to Hydrogen Peroxide solution (1→10), bubbles are formed and the color of the solution disappears.

(3) Hydrogen Peroxide responds to the test for peroxide in Identification.

Purity (1) Free Acid : 3 mL of Hydrogen Peroxide is diluted to 50 mL with freshly boiled and cooled water. When 1 mL of 0.02 N sodium hydroxide solution and 3 drops of phenolphthalein solution are added, the solution should turn red.

(2) Arsenic : It should be no more than 4.0 ppm tested by Arsenic Limit Test.

(3) Lead : To 5.0 g of Hydrogen Peroxide, add 10 mL of water. Add this solution in small portions to a beaker in a water bath. Gently heat this solution until bubbling stops. Then, the test solution, 25 mL of 0.5 N nitric acid solution, is tested by Atomic Absorption Spectrophotometry or Inductively Coupled Plasma Emission Spectroscopy and its content should not be more than 4.0 ppm.

(4) Tin : To 5.0 g of Hydrogen Peroxide, add 10 mL of water. Add this solution in small portions to a beaker in a water bath. Gently heat the solution until bubbling stops. Then the volume of the solution becomes 25 mL with 1 N hydrochloric acid. Use this as test solution. When the test solution is tested by Atomic Absorption Spectrophotometry or Inductively Coupled Plasma Emission Spectroscopy and its content should not be more than 10 ppm.

(5) Iron : To 5.0 g of Hydrogen Peroxide, add 10 mL of water. This solution is added in small portions to a beaker in a water bath. It is gently heated until bubbling subsides. Then the test solution, 0.5 N nitric acid make to 25 mL, is tested by Atomic Absorption Spectrophotometry or Inductively Coupled Plasma Emission Spectroscopy and its content should not be more than 0.5 ppm.

(6) Residue on Evaporation : Accurately weigh 50 g of Hydrogen Peroxide is added in small portions to a platinum crucible. It is gently heated and evaporated to dryness in a water bath and cooled. The residues are dried for 1 hour at 105°C and the amount should not be more than 3 mg.

(7) Phosphate : To 8 mL of Hydrogen Peroxide, add 10 mL of water and 3 mL of hydrochloric acid. It is then evaporated to dryness by gently heating in a water bath. Approximately 30 mL of warm water is added to dissolve the residues, which is then cooled. Water is added to the solution to bring the total

volume to 50 mL, Test Solution. 5 mL of Test Solution is transferred into a Nestler tube, where 4 mL of dilute sulfuric acid (1→6) and 1 mL of ammonium molybdate solution (1→20) are added. It is then well mixed by shaking and set-aside for 3 minutes, where 1 mL of 1-amino-2-naphthol-4- sulfonate solution is added. It is heated for 30 minutes in a water bath at 60°C and cooled in running water. The resulting blue color should not be deeper than that of the solution prepared by the same procedure with 5 mL of Phosphate standard solution.

Assay Dissolve about 1 g of Hydrogen Peroxide, accurately weigh, in water make to 250 mL. 25 mL of the solution is mixed with 10 mL of dilute sulfuric acid. It is then titrated with 0.1 N potassium permanganate solution.

1 mL of 0.1 N potassium permanganate solution = 1.701 mg H₂O₂

Trisodium Citrate

Sodium Citrate

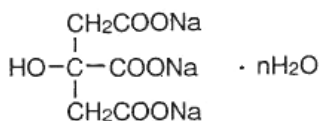

Chemical Formula: $\text{C}_6\text{H}_5\text{Na}_3\text{O}_7 \cdot n\text{H}_2\text{O}$ (n = 0, 2, 5)

Molecular Weight: 5hydrates 348.15

2hydrates 294.10

anhydrous 258.07

INS No.: 331(iii)

CAS No.: 68-04-2(anhydrous)

Synonyms: Tribasic sodium citrate; Sodium citrate

6132-04-

3(2hydrates)

Definition Trisodium citrate occurs as crystals (dihydrate, pentahydrate) called trisodium citrate (crystal) and as anhydrous material called trisodium citrate (anhydrous).

Compositional Specifications of Trisodium Citrate

Content Trisodium Citrate, when calculated on the dried basis, should contain within a range of 99.0 ~ 101.0% of trisodium citrate ($\text{C}_6\text{H}_5\text{Na}_3\text{O}_7 = 258.07$).

Description Trisodium Citrate occurs as colorless crystals or as white powder. It is odorless and has a fresh, salty taste.

Identification (1) Trisodium Citrate responds to the test for Citrate and Sodium Salt in Identification.

Purity (1) Clarity and Color of Solution : When Trisodium Citrate 1 g is dissolved in 20 mL of water, the solution should be colorless and almost clear.

(2) pH : pH of Trisodium Citrate solution (1→20) should be within a range of 7.6 ~ 9.0

(3) Sulfate : When 1 g of Trisodium Citrate is tested by Sulfate Limit Test in Identification, its content should not be more than the amount that corresponds to 0.5 mL of 0.01 N sulfuric acid.

(4) Arsenic : It should be no more than 1.3 ppm tested by Arsenic Limit Test.

(5) Lead : When 5.0 g of Trisodium Citrate is tested by Atomic Absorption Spectrophotometry or Inductively Coupled Plasma Emission Spectroscopy, its content should not be more than 1.0 ppm.

(6) Mercury : When Trisodium Citrate is tested by Mercury Limit Test, its content should not be more than 1.0 ppm.

Loss on Drying When Trisodium Citrate is dried at 180°C for 4 hours, the weight loss should be 30.3 % or less for pentahydrate, 13.5 % or less for dihydrate, and 1.0% or less for anhydrous form.

Assay Dissolve 0.2 g trisodium Citrate, previously dried at 180°C for 2 hours and accurately weighed, in

30 mL of glacial acetic acid (for non-aqueous titration) by heating. After cooling, the solution is titrated with 0.1 N perchloric acid (indicator : 1 mL of crystal violet-acetic acid solution). The end point is where the violet color of the solution changes to blue and then green. Separately, a blank test is carried out by the same procedure.

1 mL of 0.1 N perchloric acid = 8.602 mg of $C_6H_5O_7Na_3$

Hydroxycitronellal



Chemical Formula: $C_{10}H_{20}O_2$

Molecular Weight: 172.27

CAS No.: 107-75-5

Compositional Specifications of Hydroxycitronellal

Content Hydroxycitronellal should contain not less than 95.0% of hydroxycitronellal ($C_{10}H_{20}O_2$).

Description Hydroxycitronellal is a colorless to light yellow, transparent liquid having a characteristic odor.

Identification To 1 mL of Hydroxycitronellal, add 5 mL of sodium hydrogen sulfite solution, and shake. It evolves heat and dissolves. After cooling, it becomes crystalline lumps.

Purity (1) Specific Gravity : Specific gravity of Hydroxycitronellal should be within a range of 0.918 ~ 0.923.

(2) Refractive Index : Refractive Index n_D^{20} of Hydroxycitronellal should be within a range of 1.447 ~ 1.450.

(3) Clarity and Color of Solution : When 1 mL of Hydroxycitronellal is dissolved in 1 mL of 50% alcohol, the solution should be clear.

(4) Acid Value : Acid value of Hydroxycitronellal is tested by Acid Value in Flavoring Substance Test. It should not be more than 5.

Assay Accurately weigh about 1 g of Hydroxycitronellal and proceed as directed under Method 2 in Aldehyde and Ketone Content in Flavoring Substances Tests. In the procedure, allow the mixture to stand for 1 hour.

1 mL of 0.5 N hydrochloric acid = 86.13 mg of $C_{10}H_{20}O_2$

Hydroxycitronellal Dimethylacetal



Chemical Formula: $C_{12}H_{26}O_3$

Molecular Weight: 218.34

CAS No.: 107-75-5

Compositional Specifications of Hydroxycitronellal Dimethylacetal

Content Hydroxycitronellal Dimethylacetal should contain not less than 95.0% of hydroxycitronellal dimethylacetal ($C_{12}H_{26}O_3$).

Description Hydroxycitronellal Dimethylacetal is a colorless or slightly yellowish, transparent liquid having a characteristic odor.

Identification To 1 mL of Hydroxycitronellal Dimethylacetal, add 1 mL of alcohol and 1 mL of 0.5 N sulfuric acid, and heat in a water bath for about 3 minutes while shaking. An odor of hydroxycitronellal is evolved.

Purity (1) Specific Gravity : Specific gravity of Hydroxycitronellal Dimethylacetal should be within a range of 0.925 ~ 0.930.

(2) Refractive Index : Refractive Index n_D^{20} of Hydroxycitronellal Dimethylacetal should be within a range of 1.441 ~ 1.444.

(3) Clarity and Color of Solution : When 1 mL of Hydroxycitronellal Dimethylacetal is dissolved in 2 mL of 50% alcohol, the solution should be clear.

(4) Acid Value : Acid value of Hydroxycitronellal Dimethylacetal is tested by Acid Value in Flavoring Substance Test. It should not be more than 1.

(5) Hydroxycitronellal : Accurately weigh about 5 g of Hydroxycitronellal Dimethylacetal, and proceed as directed under Method 2 in Aldehyde and Ketone Content in Flavoring Substances Tests. The volume of consumed 0.5 N hydrochloric acid per 1 g of the sample should not be more than 3 %. In the procedure, allow the mixture to stand for 1 hour.

Assay Accurately weigh about 1.5 g of Hydroxycitronellal Dimethylacetal and proceed as directed under Method 1 in Aldehyde and Ketone Content in favoring Substances Tests. In the procedure, boil the mixture for 5 minutes. Calculate the content by the following formula:

$$\text{Content (\%)} = \frac{(a - b) \times 109.17}{\quad} \times 100$$

1,000

- a : Volume (mL) of consumed 0.5 N alcoholic solution of potassium hydroxide per 1 g of the sample,
b : Volume (mL) of consumed 0.5N hydrochloric acid per 1 g of the sample obtained in Purity (5).

Hydroxypropyl cellulose

INS No.: 463

Synonyms: Cellulose hydroxypropyl ether

CAS No.: 9004-64-2

Compositional Specifications of Hydroxypropyl cellulose

Content Hydroxypropyl cellulose, when calculated on the dried basis, should contain not more than 80.5% of hydroxypropoxyl group ($-\text{OC}_3\text{H}_6\text{OH}$).

Description Hydroxypropyl cellulose is scentless white ~ yellowish fibrous powder or granule.

Identification (1) When Hydroxypropyl cellulose solution (1→1000) is shaken vigorously, it generates layer of foams.

(2) When 5 mL of Hydroxypropyl cellulose solution (1→200) is added to 5 mL of 5% copper sulfate or aluminum sulfate solution, it should not be form precipitates.

Purity (1) pH : pH of Hydroxypropyl cellulose solution (1→100) should be within a range of 5.0~8.0.

(2) Propylenechlorohydrine : When it is tested by Purify (2) in 「Hydroxypropylmethylcellulose」, the content should not be more than 0.1 ppm.

(3) Lead : Accurately weigh about 5 g of Hydroxypropyl cellulose and transfer into a platinum or quartz crucible. Add minute amounts of sulfuric acid and wet, slowly heat the solution and pre-ash at the temperature as low as possible. Again add 1 mL of sulfuric acid, slowly heat, ignite until it is ashed at 450 ~ 550°C. After completing ashing, add minute amounts of nitric acid(1→150) to the residue, and dissolved. Add Nitric acid(1→150) again to make 10 mL, test solution. When 5 g of the test solution is tested by Atomic Absorption Spectrophotometry or Inductively Coupled Plasma Emission Spectroscopy, its content should not be more than 2.0 ppm.

Loss on Drying When Hydroxypropyl cellulose is dried for 4 hours at 105°C, the weight loss should not be more than 10.0%.

Residue on Ignition Residue on ignition of Hydroxypropyl cellulose should not be more than 0.5%.

Assay About 0.065 g of Hydroxypropyl cellulose, previously dried and accurately weighed, is transferred into a 5 mL-vial equipped with a pressure tight septum closure, and 0.065 g of adipic acid, 2.0 mL of the inner standard solution, and 2.0 mL of hydrogen iodide are added, the vial is stoppered, and its weight is then accurately measured. However, Octane.o-xylene solution(1→25) is used as the inner standard solution. The bottle is shaken for 30 sec for mixing, and heated at 150°C for 30 minutes while shaking and mixing every 5 minute. Then the vial is heated for 30 minutes, cooled and the weight is again accurately measured. When the weight loss is not more than 0.01 g, the supernatant is used as the test solution. Separately, 0.065 g of adipic acid, 2.0 mL of the inner standard solution, and 2.0 mL of hydrogen iodide are put in another pressure tight vial, which is then stoppered, and the weight is

measured accurately. 50 μl of isopropyl iodide is added and the weigh is measured again accurately. After the bottle is shaken for 30 sec, the supernatant is used as the standard solution. 1 μl each of the test solutions and standard solutions is injected to gas chromatograph and the content(%) of the hydroxypropoxyl group is obtained using the following equation.

$$\text{the content(\% of the hydroxypropoxyl group (\%))} = \frac{Q_t}{Q_s} \times \frac{W_s}{\text{Weight of sample(g)}} \times 44.17$$

W_s : Amount (mg) of isopropyl iodide in the standard solution(g)

Q_t : The ratio of the peak area of isopropyl iodide to that of octane in the standard solution

Q_s : The ratio of the peak area of isopropyl iodide to that of octane in the test solution

Pressure tight vial : 5 mL of internal pressure bottle with stopper made of glass. Inner part of the bottom is cone shaped, 20 mm external diameter, 50mm height and the capacity to 30 mm is 2 mL. thermal resistance resin, fluoroplastic are used for a stopper and inner stopper, respectively. However, when heating before use, check if the content does not leak.

Heater : Metal aluminum block with 60 ~ 80mm height, having a hole with a diameter of 20.6mm, 32mm height. Heater be used which the inner temperature of block should be controlled at the range of 1°C.

Operation Condition

Capillary Column : DB-5 or its equivalent

Detector : Hydrogen Flame Ionization Detector (FID)

Column Temperature : 100°C

Carrier gas : Helium

Flow rate : Adjust to make the peak of octane appear about after 10 minutes

Selection of Column : 1 μl of standard solution is weighed and operated under following operation condition, it is spilled in order of isopropyl iodide, octane. The column that each peak is completely separated should be used.

Hydroxypropylmethylcellulose

INS No.: 464

CAS No.: 9004-65-3

Compositional Specifications of Hydroxypropylmethylcellulose

Content Hydroxypropylmethylcellulose, when calculated on the dried basis, should contain within a range of 19.0 ~ 30.0% methoxyl group ($-\text{OCH}_3$: 31.04) and 3.0~12.0% hydroxypropoxyl group ($-\text{OCH}_2\text{CHOHCH}_2$: 75.09).

Description Hydroxypropylmethylcellulose is scentless white ~ yellow fibrous powder or granule.

Identification (1) When an aqueous solution (0.1→100) of Hydroxypropylmethylcellulose is shaken vigorously, it generates layer of foams.

(2) When 5 mL of an aqueous solution (0.5→100) of Hydroxypropylmethyl cellulose is added to 5 mL of 5% copper sulfate or aluminum sulfate solution, it should not be form precipitates.

Purity (1) pH : Approximately 1 g of Hydroxypropylmethylcellulose is dissolved in water so that volume to make 100 mL. It should be within a range of 5.0~8.0.

(2) Propylenechlorohydrine : Weigh 1g of the sample into a centrifue tube and record weight to the nearest 0.18. Quantitatively add 5.0mL diethyl ether to the sample and sonicates for 10minutes. Centrifuge the smaple to separate the mixture. Remove a portion of the diethyl ether extract for CTC analysis. Separately, accurately weigh 0.1 g of propylene chlorohydrin(Aldrich 292087, the mixture of 70% 1-Chloro-2- propanol and 25% 2-Chloro-1- propanol), bring to a final volume of 100mL with diethyl ether. Perform serial dilutions (in diethyl ether) of stack standard to achieve a working calibration rane of 6-25 ng /mL. Inject 1 μ l of both test and standard solutions into gas chromatography with following operation condition. Standard calibration curve is obtained from the peak area against the concentration (ng/mL) of the each standard solution. Measure peak area of Propylenechlorohydrine in test solution, calculate the content of Propylenechlorohydrine from prepared calibration curve, and its content should not be more than 0.1 ppm.

Operation Condition

Capillary Column : DB-WAX(30m×0.53mm, 1 μ m) or its equivalent

Detector : Electron Capture Detector(ECD)

Temperature at injection hole : 200°C

Column Temperature : held at 35°C for 7 minutes, raised to 200°C at a rate of 8°C per minute and held at 200°C for 5 minutes.

Detector Temperature : 230°C

Carrier gas : Nitrogen or helium

Flow rate : Adjust retention time about 11.7 minutes for 1-chloro-2-propanol, and about 12.5 minutes for 2-chloro-1-propanol

(3) Lead : When 5.0 g of Hydroxypropylmethylcellulose is tested by Atomic Absorption Spectrophotometry or Inductively Coupled Plasma Emission Spectroscopy, its content should not be more than 2.0 ppm.

(4) Cadmium : When 5.0 g of Hydroxypropylmethylcellulose is tested by Atomic Absorption Spectrophotometry or Inductively Coupled Plasma Emission Spectroscopy, its content should not be more than 1.0 ppm.

(5) Mercury : When Hydroxypropylmethylcellulose is tested by Mercury Limit Test, its content should not be more than 1.0 ppm.

Loss on Drying When Hydroxypropylmethylcellulose is dried for 3 hours at 105°C, the loss should not be more than 10%.

Residue on Ignition Residue after ignition should not be more than 1.5% when viscosity is 50 cps or higher and not more than 3.0% when viscosity is 50 cps or less. Viscosity is measured according to Purity (1) of「Methylcellulose」.

Assay Approximately 65 mg of Hydroxypropylmethylcellulose is precisely weighed into a bottle for decomposition (5 mL glass bottle that has a stopper with pressure lining). 65 mg of adipic acid, 2.0 mL of internal standard solution, and 2.0 mL of hydroiodic acid (must be handled carefully) are added to the bottle and a stopper is placed, which is precisely weighed. The bottle is shaken for 30 seconds, heated for 20 minutes at 150°C, carefully shaken, and heated for 40 minutes again. After cooling for 45 minutes, the weight is precisely weighed. If the weight loss is less than 10 mg, the supernatant is used as Test Solution. Separately, 65 mg of adipic acid, 2.0 mL of internal standard solution, and 2 mL of hydroiodic acid are added to a bottle for decomposition. After placing a stopper, it is weighed precisely. 15 µl of isopropyl iodide is added and weighed precisely. Using the same procedure, 45 µl of methyl iodide is added and weighed. After shaking the bottle for 30 seconds, the supernatant is used as Standard Solution. 1µl of each solution is injected into a gas chromatography and the contents (%) of methoxyl group and hydroxypropoxyl group are obtained using the following equation.

$$\text{Content of methoxyl group(\%)} = \frac{Q_{Ta}}{Q_{Sa}} \times \frac{W_{Sa}}{\text{weight of the sample(mg)}} \times 21.86$$

$$\text{Content of hydroxypropoxyl group(\%)} = \frac{Q_{Tb}}{Q_{Sb}} \times \frac{W_{Sb}}{\text{weight of the sample(mg)}} \times 44.17$$

W_{Sa} : The amount of methyl iodide in Standard Solution (mg)

W_{Sb} : The amount of isopropyl iodide in Standard Solution (mg)

Q_{Sa} , Q_{Sb} : Peak area ratios of methyl iodide and isopropyl iodide vs. internal standard in Standard Solution

Q_{Ta} , Q_{Tb} : Peak area ratios of methyl iodide and isopropyl iodide vs. internal standard in Test Solution

Operation Conditions

- Column : Diatomite for gas chromatography (Chromosorb WHP or its equivalent) coated with 10% methyl silicone oil or its equivalent
- Detector : Thermal Conductivity Detector (TCD) or (Hydrogen) Flame Ionization Detector (FID)
- Temperature at injection hole: 200°C
- Column Temperature : 50°C
- Detector Temperature : 200°C
- Carrier gas : Nitrogen or Helium
- Retention Time : In the order of methyl iodide, isopropyl iodide, and toluene
- Internal Standard Solution : 0.25 g of toluene is precisely weighed and dissolved in o-xylene (total volume 50 mL)

Hypochlorous Acid Water

Definition Hypochlorous Acid Water is obtained by electrolysis of hydrochloric acid or saline solution and main ingredient is Hypochlorous Acid. Strongly acidic hypochlorous acid water (aqueous solution obtained from both poles by electrolyzing sodium chloride (not more than 0.2%) in an electrolytic bath with septum composed of anode and cathode, which are separated by septum), moderately acidic hypochlorous acid water (aqueous solution obtained from both poles by electrolyzing an valid concentration of sodium chloride in an electrolytic bath with septum composed of anode and cathode, which are separated by septum or solution that collect under the anodes added solution that collect under the cathode) and slightly acidic hypochlorous acid water (aqueous solution, which is adjusted with valid concentration after adding sodium chloride to the hypochlorous acid water, in an aseptate electrolytic bath without septum) are included in this material.

Compositional Specifications of Hypochlorous Acid Water

Content When Hypochlorous Acid Water is quantified, strongly acidic Hypochlorous Acid Water should contain 20~60 ppm of active chlorine, moderately acidic Hypochlorous Acid Water should contain 10~60 ppm of active chlorine and slightly acidic Hypochlorous Acid Water should contain 10~80 ppm of active chlorine.

Description Hypochlorous Acid Water is colorless, odorless or with slight odor of chlorine.

Identification (1) To 5 mL of Hypochlorous Acid Water, 1 mL of sodium hydroxide(1→2,500) and 0.2 mL of potassium iodide are added, then yellow color develops. When 0.5 mL of starch solution is added to this solution, blue color develops.

(2) To 5 mL of Hypochlorous Acid Water, 0.1 mL of potassium permanganate solution(1→300) and 1 mL of sulfuric acid(1→20) is added, then red violet color doesn't fade.

(3) To 90 mL of Hypochlorous Acid Water, 100 mL of sodium hydroxide(1→5) is added, then the solution exhibits an absorption maximum at a wavelength of 290~294 nm.

Purity (1) pH : When pH is determined by glass electrode method, not more than 2.7 for strongly acidic Hypochlorous Acid Water, 2.7~5.0 for moderately acidic Hypochlorous Acid Water and 5.0~6.5 for slightly acidic Hypochlorous Acid Water.

(2) Residue on Evaporation : When 20.0g of Hypochlorous Acid Water is dried for 2 hours at 110°C after water is evaporated, the residue should not be more than 0.25%.

Assay 200 g of Hypochlorous Acid Water is precisely weighed, 2 g of potassium iodide and 10 mL of acetic acid(1→4) are added, immediately place with a stopper, and set aside in a dark place for 15 minutes. Titrate the liberated iodine with 0.01 M sodium thiosulfate (indicator : starch solution). Separately, a blank experiment is done in the same manner.

1 mL of 0.01M sodium thiosulfate solution = 0.35453mg Cl

Inositol

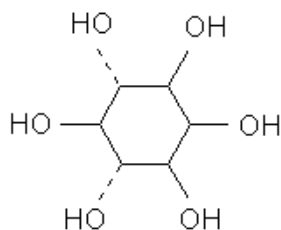

Chemical Formula: $C_6H_{12}O_6$

Molecular Weight: 180.16

Synonyms: 1,2,3,5/4,6-Cyclohexanehexol; meso-Inositol

CAS No.: 87-89-8

Definition Inositol is obtained from decomposition of phytic acid or by separating nectar or molasses of beet (*Beta vulgaris* LINNE var. *rapa* DUMORTIER) of chenopodiaceae. Its major component is inositol.

Compositional Specifications of Inositol

Content After drying, Inositol should contain not less than 97.0% of inositol ($C_6H_{12}O_6$).

Description Inositol is fine, white crystal or crystalline powder with odorless and sweet taste.

Identification (1) 6 mL of nitric acid is added to 1 mL of aqueous solution (1→50), which is then evaporated to dryness in a water bath. The residues are dissolved in 1 mL of water, where 0.5 mL of strontium acetate solution (1→10) is added. When this solution is again evaporated to dryness in a water bath, the resultant residue shows red color.

(2) Melting point of hexaacetyl inositol obtained in Assay is 212~216°C.

Purity (1) Melting Point : Melting point should be in a temperature range of 224~227°C.

(2) Chlorides : When 2 g of Inositol is tested for chlorides, the content should not be more than the amount that corresponds to 0.3 mL of 0.01 N hydrochloric acid.

(3) Sulfates : When 4 g of Inositol is tested for sulfates, the content should not be more than the amount that corresponds to 0.5 mL of 0.01 N sulfuric acid.

(4) Calcium : 1 g of Inositol is dissolved in 10 mL of water and 1 mL of ammonium hydroxide solution is added. The resultant solution remains clear for at least 1 minute.

(5) Arsenic : It should be no more than 2.0 ppm tested by Arsenic Limit Test.

(6) Lead : When 5.0 g of Inositol is tested by Atomic Absorption Spectrophotometry or Inductively Coupled Plasma Emission Spectroscopy, its content should not be more than 4.0 ppm.

Loss on Drying When Inositol is dried for 4 hours at 105°C, the weight loss should not be more than 0.5%.

Residue on Ignition After drying at 105°C for 4 hours, it is tested by Residue on Ignition, the amount of

residue should not be more than 0.1%.

Assay Inositol is dried for 4 hours at 105°C. Approximately 0.2 g of Inositol is precisely weighed into a 250 mL beaker, where a mixture of 1 mL dilute sulfuric acid and 50 mL anhydrous acetic acid is added. The beaker is covered with a watch glass and heated for 20 minutes in a water bath. It is then chilled in a ice bath. 100 mL of water is added to the beaker, which is boiled for 20 minutes. After cooling, the solution is transferred into a separatory funnel. The beaker is washed with a small amount of water, which is added to the funnel. The beaker is washed with six successive 30 mL, 25 mL, 20 mL, 15 mL, 10 mL, and 5 mL of chloroform, then extracted, combined all chloroform extracts, and washed with 10 mL of water. The extract is then filtered through a pledget of cotton, which is washed with 10 mL of chloroform. The filtrate and the washings are combined and evaporated to dryness in a water bath. The residue is dried of 4 hours at 105°C. After cooling, the residue is weighed to obtain the amount of hexaacetyl inositol ($C_{18}H_{24}O_{12}$). The content of inositol is calculated by the following equation.

$$\text{Weight of Inositol } (C_6H_{12}O_6) \text{ (mg)} = \text{Weight of Hexaacetyl Inositol } (C_{18}H_{24}O_{12}) \text{ (mg)} \times 0.4167$$

Invertase

β -Fructofuranosidase

Definition Invertase is an enzyme obtained from the culture of *Aspergillus aculeatus* and its variety, *Aspergillus awamori* and its variety, *Aspergillus niger* and its variety, *Arthrobacter genus*, *Bacillus genus*, *Kluyveromyces lactis* and its variety, *Saccharomyces cerevisiae* and its variety. Dilutant or stabilizer can be added for the purpose of activity adjustment and quality preservation.

Compositional Specifications of Invertase

Description Invertase is white ~ deep brown powder, particle, paste or colorless ~ deep brown liquid.

Identification When Invertase is proceeded as directed under Activity Test, it should have the activity as Invertase.

Purity (1) Arsenic : It should be no more than 4.0 ppm tested by Arsenic Limit Test.

(2) Lead : When 5.0 g of Invertase is tested by Atomic Absorption Spectrophotometry or Inductively Coupled Plasma Emission Spectroscopy, its content should not be more than 5.0 ppm.

(3) Cadmium : When 5.0 g of Invertase is tested by Atomic Absorption Spectrophotometry or Inductively Coupled Plasma Emission Spectroscopy, its content should not be more than 0.5 ppm.

(4) Coliform Group : Invertase is tested by Microbe Test Methods for Coliform Group in General Test Methods in 「Standards and Specifications for Foods」. It should contain 30 colonies or less per 1g of this product.

(5) Salmonella : Invertase is tested by Microbe Test Methods for Salmonella in General Test Methods in 「Standards and Specifications for Foods」. It should be negative (-).

(6) Total Viable Aerobic Count : When Invertase is tested by Microbe Test Methods for Total Viable Aerobic Count (Number of General Germs) in General Test Method in 「Standards and Specifications for Foods」, it should not be more than 50,000 colonies per 1 g.

(7) E. Coli : When Invertase is tested by Microbe Test Methods for E. Coli in General Test Method 「Standards and Specifications for Foods」, it should be negative (-).

Activity Test (Activity)

- Analysis Principle : Activity test is based on hydrolysis of sucrose (30 minutes, pH 4.5, 20°C). The degree of hydrolysis is measured by optical rotation of the solution using a polarimeter.
- Preparation of Test Solution : The test solution is prepared to obtain the 10 mL of final diluted solution for which the measured specific rotation using 2 dm cell will fall within 0~+20. When the sample is solid, it is ground in a mortar adding 5 times or more amount of water. This is transferred into a volumetric flask, which is then diluted to a proper concentration. Liquid sample is directly diluted with water.
- Test Procedure : 100 mL of substrate solution is placed in a 100~110 mL flask and equilibrated at 20 ± 0.1°C for 15 minutes in a water bath. Precisely 10 mL of Test Solution is added to the flask, which is

turned upside down 5 ~ 6 times to ensure thorough mix and allowed to stand for 30 minutes in a water bath. If there are significant amount of insoluble substances, the flask is shaken every 10 minutes and mixed. When the time is up, approximately 2 g of sodium carbonate (1 hydrate) is added and dissolved by shaking. If the solution is not alkaline, sodium carbonate is added to alkalize the solution. 5 mL of this solution is transferred into a 100 mL volumetric flask, where 6 drops of neutral lead acetate solution are added and water is added to bring the total volume to 100 mL. 3 g of filtering aid such as cellulose type agglomeration agent is added to the solution, which is then filtered through Whatman No.1 filter paper. First 3 mL of filtrate is discarded. The filtrate should be completely clear. A blank test is carried out with 100 mL of water containing 10 mL of Test Solution by processing as the same as the enzyme digesting solution. Polarimeter tube is washed 3 times with the Test Solution and filled with Test Solution. It is then set up in the polarimeter and a thermometer (10~30°C range with 0.1°C scale) is inserted. It is then allowed to be equilibrated at 20°C. Each of solution is measured 5 times and measured value is averaged. The complete sample value is obtained by subtracting black value from sample value. Polarimeter tube should be used Path length of 2dm. If 1 dm path length is used, it should be corrected. A standard curve is prepared by using the values of activity and specific rotation (in Ventzke degree : °Ventzke).

(note : specific rotation = °Ventzke × 0.346).

Activity	Polarization Reading
0.960	0
0.735	+5
0.570	+10
0.420	+15
0.300	+20
0.190	+25
0.090	+30

Activity (A) of Test Solution is obtained from standard curve by interpolation. When the Test Solution is measured at 20°C or higher, 0.004 is subtracted from the activity per 1°C. When the Test Solution is measured at 20°C or lower, 0.004 is added to the activity per 1°C.

The activity of the enzyme is calculated using the following equation.

$$IA, \text{ units/g} = A \times 2 \times \frac{1,000}{W}$$

2 : dilution factor

1,000 : conversion factor (mg to g)

W : Weight of sample in 10 mL of Test Solution (mg)

Definition of activity : 1 invertase unit corresponds to the amount of enzyme that hydrolyzes 77% of sucrose used in the above test conditions.

Solutions

- Phosphate Buffer Solutions : 115 g of sodium phosphate, monobasic ($\text{NaH}_2\text{PO}_4 \cdot \text{H}_2\text{O}$) is dissolved in water and make 500 mL.
- Substrate Solution : 100 g of sucrose is dissolved in 300 mL of water, where 20 mL of phosphate buffer solution is added. The total volume of the solution is brought up to 1,000 mL with water.
- Neutral Lead Acetate Solution : 31 g of lead acetate ($\text{C}_4\text{H}_6\text{PbO}_4 \cdot 3\text{H}_2\text{O}$) is dissolved in 50 mL of water. pH of the solution is adjusted to 7.0 with sodium hydroxide solution and the total volume is brought up to 80 mL with water. The solution is filtered through a Whatman No.1 filter paper or its equivalent. The filtrate is stored in a container with a stopper.

Storage Standard of Invertase

Invertase should be stored sealing tightly in a cold dark place.

Ion Exchange Resins

Definition Ion Exchange Resins occur as granules, powders, and suspensions called Ion Exchange Resin (granule), Ion Exchange Resin (powder), and Ion Exchange Resin (suspension), respectively.

A. Content Specifications of Ion Exchange Resins (Granular Form)

Description Ion Exchange Resin (granule) occurs as a black, brown, light red-brown, or white, spherical mass, or granular substance. It is almost odorless.

Identification (1) Cation Exchange Resin : Make a resin column pouring 5 mL of Ion Exchange Resin (granule) with water into a glass tube for chromatography (internal diameter: about 1 cm). Flow 25 mL of diluted hydrochloric acid (1→10) at a rate of about 5 mL per minute. and wash by flowing 100 mL of water at the same rate. Flow 25 mL of potassium hydroxide solution (1→15) at the same rate, and wash again by flowing 75 mL of water at the same rate. To 5 mL of the last washings, add 2 mL of diluted acetic acid (1→20), and add 3 drops of sodium cobalt nitrite solution. No yellow turbidity appears. Transfer 2 mL of the resin of the resin column into a test tube, add 5 mL of diluted hydrochloric acid (1→9), shake well for 5 minutes, and filter. Wash the resin on the filter paper with water, and combine the filtrate and the washings to make about 5 mL. Add 4 mL of sodium hydroxide solution (1→25) to the solution, shake, add 2 mL of diluted acetic acid (1→20), and add 3 drops of sodium cobalt nitrite solution. A yellow precipitate is formed.

(2) Anion Exchange Resin : Make a resin column pouring 5 mL of Ion Exchange Resin (granule) with water into a glass tube for chromatography (internal diameter : about 1 cm). Flow 25 mL of diluted hydrochloric acid (1→10) at a rate of about 5 mL per minute, and wash by flowing 100 mL of water at the same rate. To 5 mL of the last washings, add 1 mL of diluted nitric acid (1→9), and add 3 drops of silver nitrate solution (1→50). No white turbidity appears. Transfer 1 mL of the resin of the resin column into a test tube, add 3 mL of sodium hydroxide solution (1→25), shake well for 5 minutes, and filter. Wash the resin on the filter paper with water, and combine the filtrate and the washings to make about 5 mL. Add 3 mL of diluted nitric acid (1→9) to the solution, and add 3 drops of silver nitrate solution (1→50). A white precipitate is formed.

Purity Prepare the sample of the cation exchange resin or the anion exchange resin by ① or ② as appropriate, given below, immerse thoroughly in water, and blot the adhering water with a filter paper, and use as sample.

① Cation Exchange Resin : Measure 25 mL of Ion Exchange Resin (granule), transfer into a glass tube for chromatography (internal diameter : about 3 cm), flow 1,000 mL of 10% hydrochloric acid at a rate of 15 ~ 20 mL per minute, and wash by flowing water at the same rate. Measure 10 mL of the washings, and perform the test by Chloride Limit Test. Wash with water until the amount is not more than the amount corresponding to 0.3 mL of 0.01 N hydrochloric acid and then prepared the sample (H form).

② Anion Exchange Resin : Measure 25 mL of Ion Exchange Resin (granule), transfer into a glass tube for chromatography (internal diameter : about 3 cm), flow 1,000 mL of 4% sodium hydroxide solution at a rate of 15 ~ 20 mL per minute, and wash by flowing water at the same rate. Wash with water until the washings become neutral with phenolphthalein solution. and then prepare the sample (OH form)

(1) Solids : Weigh 10 g of Ion Exchange Resins. In the case of the cation exchange resin, dry at 100°C for 12 hours, and weigh again; in the case of the anion exchange resin, dry at 40°C for 12 hours in a vacuum desiccator at 30 mmHg, and weigh again. The amount of residue should not be less than 2.5 mg.

(2) Water-Soluble Substances : Weigh 10 g of Ion Exchange Resins, transfer into a cylindrical filter (internal diameter : 28 mm, length : 100 mm), suspend in 1,000 mL of water, and extract for 5 hours while shaking occasionally. Measure 50 mL of the extract, evaporate carefully, and dry at 110°C for 3 hours. Weigh the amount of the residue should not be more than 2.5 mg. Perform a blank test in the same manner.

(3) Arsenic : It should be no more than 4.0 ppm tested by Arsenic Limit Test.

(4) Lead : When 5.0 g of Ion Exchange Resins is tested by Atomic Absorption Spectrophotometry or Inductively Coupled Plasma Emission Spectroscopy, its content should not be more than 2.0 ppm.

Total Ion Exchange Capacity

① Cation Exchange Resin : Accurately weigh about 5 g of Ion Exchange Resins prepared in Purity. Add 500 mL of 0.2 N sodium hydroxide, exactly measured, and allow to stand for 12 hours while shaking occasionally. Measure exactly 10 mL of the supernatant, and titrate with 0.1 N sulfuric acid (indicator : 3 drops of methyl orange solution). Perform a blank test in the same manner, and calculate the total ion exchange capacity by the following formula : Not less than 1.0 milliequivalent/g.

Total ion exchange capacity =

$$\frac{\text{Volume of 0.1N sulfuric acid consumed in the blank test(mL)} - \text{Volume of 0.1N sulfuric acid consumed in this test(mL)}}{\text{weight of the sample(g)} \times \frac{\text{Solid(\%)}}{100}} \times 5(\text{milliequivalen/g})$$

② Anion Exchange Resin : Accurately weigh about 5 g of sample A prepared in Purity. Add 500 mL of 0.2 N hydrochloric acid, exactly measured, and allow to stand for 12 hours while shaking occasionally. Measure exactly 10 mL of the supernatant, and titrate with 0.1 N sodium hydroxide (indicator: 3 drops of phenolphthalein solution). Perform a blank test in the same manner, and calculate the total ion exchange capacity by he following formula : Not less than 1.0 milliequivalent/g.

Total ion exchange capacity =

$$\frac{\text{Volume of 0.1N sodium hydroxide consumed in the blank test (mL)} - \text{Volume of 0.1N sodium hydroxide consumed in this test (mL)}}{\text{weight of the sample (g)} \times \frac{\text{Solid (\%)}}{100}} \times 5 (\text{milliequivalen/g})$$

B. Content Specifications of Ion Exchange Resins (Powder Form)

Description Ion Exchange Resin (powder) occurs as a black, brown, light brown, or white, powder. It is almost odorless.

Identification (1) Cation Exchange Resin : Make a layer of resin, pouring 2 g of Ion Exchange Resin (powder) with water into a pressure filter with membrane filter (internal Diameter: about 7.5 cm, pore size : 1 μm). Flow 25 mL of diluted hydrochloric acid (1 \rightarrow 9) at a rate of about 5 mL per minute. and wash by flowing 100 mL of water at the same rate. Flow 25 mL of potassium hydroxide solution (1 \rightarrow 15) at the same rate, and wash again by flowing 75 mL of water at the same rate. To 5 mL of the last washings, add 2 mL of diluted acetic acid (1 \rightarrow 20), and add 3 drops of sodium cobalt nitrite solution. Not yellow turbidity appears. Transfer 0.5 g of the resin of the pressure filter into a test tube, add 5 mL of diluted hydrochloric acid (1 \rightarrow 9), shake well for 5 minutes, and filter. Wash the resin on the filter paper with water, and combine the filtrate and the washings to make about 5 mL. Add 4 mL of sodium hydroxide solution (1 \rightarrow 25) to the solution, shake, add 2 mL of diluted acetic acid (1 \rightarrow 20), and add 3 drops of sodium cobalt nitrite solution. A yellow precipitate is formed.

(2) Anion Exchange Resin : Make a layer of resin, pouring 2 g of Ion Exchange Resin (powder) with water into a pressure filter with membrane filter (internal Diameter : about 7.5 cm, pore size : 1 μm). Flow 25 mL of diluted hydrochloric acid (1 \rightarrow 9) at a rate of about 5 mL per minute, and wash by flowing 100 mL of water at the same rate. To 5 mL of the last washings, add 1 mL of diluted nitric acid (1 \rightarrow 9), and add 3 drops of silver nitrate solution (1 \rightarrow 50). Not white turbidity appears. Transfer 0.5 g of the resin of the resin column into a test tube, add 3 mL of sodium hydroxide solution (1 \rightarrow 25), shake well for 5 minutes, and filter. Wash the resin on the filter paper with water, and combine the filtrate and the washings to make about 5 mL. Add 3 mL of diluted nitric acid (1 \rightarrow 9) to the solution, and add 3 drops of silver nitrate solution (1 \rightarrow 50). A white precipitate is formed.

Purity Prepare the sample of the cation exchange resin or the anion exchange resin by ① or ② as appropriate, given below, immerse thoroughly in water, and blot the adhering water with a filter paper, and use as sample.

① Cation Exchange Resin : Make a layer of resin, add 10 g of Ion Exchange Resin (powder) into a

vaccum filter with membrane filter (internal diameter : about 7.5 cm, pore size : 1 μm), flow 1,000 mL of diluted hydrochloric acid (1→10) at a rate of 15 ~ 20 mL per minute, and wash by flowing water at the same rate. Measure 10 mL of the washings, and perform the test by Chloride Limit Test. Wash with water until the amount is not more than the amount corresponding to 0.3 mL of 0.01 N hydrochloric acid, and then prepared the sample (H form)

② Anion Exchange Resin : Make a layer of resin, add 10 g of Ion Exchange Resin (powder) into a vaccum filter with membrane filter (internal diameter : about 7.5 cm, pore size : 1 μm), flow 1,000 mL of sodium hydroxide solution (1→25) at a rate of 15~20 mL per minute, and wash by flowing water at the same rate. Wash with water until the washings become neutral with phenolphthalein solution, and then prepare the sample (OH form).

(1) Solids : Proceed as directed under Purity (1) in 「Ion exchange Resin (Granule)」.

(2) Water Solubles : 10 g of Ion Exchange Resin (powder) is suspended in 1,000 mL of water. It is then extracted for 5 hours while stirring occasionally. The suspension is pressure filtered through a 7.5 cm membrane filter (1 μm pore size). 50 mL of the filtrate is carefully evaporated and further dried for 3 hours at 110°C. The residue should not be more than 2.5 mg.

(3) Arsenic : Proceed as directed under Purity (3) in 「Ion exchange Resin (Granule)」.

(4) Lead : When 5.0 g of Ion exchange Resin (Granule) is tested by Atomic Absorption Spectrophotometry or Inductively Coupled Plasma Emission Spectroscopy, its content should not be more than 2.0 ppm.

Total Ion Exchange Capacity

① Cation Exchange Resin : Accurately weigh about 5 g of sample prepared in Purity. Add 500 mL of 0.2 N sodium hydroxide, exactly measured, and allow to stand for 12 hours while shaking occasionally. The suspension is pressure-filtered through a 7.5 cm membrane filter (1 μm pore size). Measure exactly 10 mL of the supernatant, and titrate with 0.1 N sulfuric acid (indicator : 3 drops of methyl orange solution). Perform a blank test in the same manner, and calculate the total ion exchange capacity by the following formula : Not less than 1.0 milliequivalent/g.

Total ion exchange capacity =

$$\frac{\text{Volume of 0.1N sulfuric acid consumed in the blank test(mL)} - \text{Volume of 0.1N sulfuric acid consumed in this test(mL)}}{\text{weight of the sample(g)} \times \frac{\text{Solid(\%)}}{100}} \times 5(\text{milliequivalen/g})$$

② Anion Exchange Resin : Accurately weigh about 5 g of sample prepared in Purity. Add 500 mL of 0.2 N hydrochloric acid, exactly measured, and allow to stand for 12 hours while shaking occasionally. The suspension is pressure-filtered through a 7.5 cm membrane filter (1 μm pore size). Measure exactly 10

mL of the supernatant, and titrate with 0.1 N sodium hydroxide (indicator : 3 drops of phenolphthalein solution). Separately, a blank test is carried out by the same procedure and total ion exchange capacity is obtained by the following equation. It should not be less than 1.0 milliequivalent/g.

Total ion exchange capacity =

$$\frac{\text{Volume of 0.1N sodium hydroxide consumed in the blank test(mL)} - \text{Volume of 0.1N sodium hydroxide consumed in this test(mL)}}{\text{weight of the sample(g)} \times \frac{\text{Solid(\%)}}{100}} \times 5(\text{milliequivalen/g})$$

C. Content Specifications of Ion Exchange Resins (Suspension)

Description Ion Exchange Resins (Suspension) is brown, pale reddish brown, or white suspension. It is almost odorless.

Identification (1) Cation Exchange Resin : 0.5 mL of Ion Exchange Resins (Suspension) is mixed with 5 mL of water and 1 mL of strongly acidic cation exchange resin, which is reacted for 1 hour while shaking. It is filtered through gauze. 0.3 g of sodium chloride is added and mixed for 3 minutes, where 1 drop of methyl red solution is added. The liquid turns red.

(2) Anion Exchange Resin : 0.5 mL of Ion Exchange Resins (Suspension) is mixed with 5 mL of water and 1 mL of strongly alkaline anion exchange resin, which is reacted for 1 hour while shaking. It is filtered through gauze. 0.3 g of sodium chloride is added and mixed for 3 minutes, where 1 drop of phenolphthalein solution is added. The liquid turns pink.

Purity (1) Solids : 1 g of Ion Exchange Resins (Suspension) is precisely weighed and dried for 5 hours at 105°C and weighed. It should not be less than 40 mg.

(2) Water Solubles : 100 mL of Ion Exchange Resins (Suspension) is pressure-filtered through a 7.5 cm membrane filter (1 µm pore size). 10 mL of the filtrate is carefully evaporated and then dried for 3 hours at 105°C. The residue should not be more than 50 mg.

(3) Arsenic : It should be no more than 4.0 ppm tested by Arsenic Limit Test.

(4) Lead : When 5.0 g of Ion Exchange Resin (Suspension) is tested by Atomic Absorption Spectrophotometry or Inductively Coupled Plasma Emission Spectroscopy, its content should not be more than 2.0 ppm.

Total Ion Exchange Capacity

① Cation Exchange Resin : An equivalent amount of 0.2 g of solid is precisely weighed and eluded through a chromatography glass tube (inner diameter : 1cm) at a flow rate of approximately 2 mL per minute. This glass tube is filled with 10 mL of strongly acidic cation exchange resin. Again,

approximately 80 mL of water is eluded at a flow rate of approximately 15 ~ 20 mL per minute. The effluent and rinse water are combined, where approximately 1 g of sodium chloride is added. It is then titrated with 0.1 N sodium hydroxide solution using a pH meter until the pH of the solution becomes 7.0. Separately, a blank test is carried out and the total ion exchange capacity is obtained by the following equation. It should not be less than 1.0 milliequivalent/g.

Total ion exchange capacity =

$$\frac{\text{Volume of 0.1N sodium hydroxide consumed in the blank test(mL)} - \text{Volume of 0.1N sodium hydroxide consumed in this test(mL)}}{\text{weight of the sample(g)} \times \frac{\text{Solid(\%)}}{100}} \times 5(\text{milliequivalen/g})$$

② Anion Exchange Resin : An equivalent amount of 0.2 g of solid is precisely weighed and eluded through a chromatography glass tube (inner diameter : 1cm) at a flow rate of approximately 2 mL per minute. This glass tube is filled 10 mL of strongly alkaline anion exchange resin. Again, approximately 80 mL of water is eluded at a flow rate of approximately 15 ~ 20 mL per minute. The effluent and rinse water are combined, where approximately 1 g of sodium chloride is added. It is then titrated with 0.1 N hydrochloric acid using a pH meter until the pH of the solution becomes 7.0. Separately, a blank test is carried out and the total ion exchange capacity is obtained by the following equation. It should not be less than 1.0 milliequivalent/g.

Total ion exchange capacity =

$$\frac{\text{Volume of 0.1N hydrochloric acid consumed in the blank test(mL)} - \text{Volume of 0.1N hydrochloric acid consumed in this test(mL)}}{\text{weight of the sample(g)} \times \frac{\text{Solid(\%)}}{100}} \times 5(\text{milliequivalen/g})$$

α -Ionone

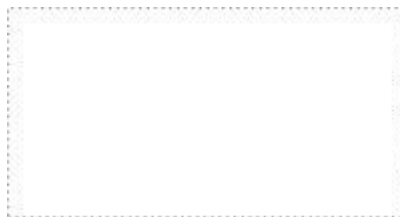

Chemical Formula: $C_{13}H_{20}O$

Molecular Weight: 192.30

이명: 4-(2,6,6-Trimethyl-2-cyclohexenyl)- 3-
butene-2-one

CAS No.: 127-41-3

Compositional Specifications of α -Ionone

Content α -Ionone should contain not less than 90.0% of α -Ionone ($C_{13}H_{20}O$).

Description α -Ionone is a colorless to light yellow transparent liquid having a characteristic odor.

Identification (1) To 1 drop of α -Ionone, add 1 mL of water, shake well, add 2 drops of sodium nitroprusside solution, add 2 drops of sodium hydroxide solution (3 \rightarrow 10), and shake. An orange-red color develops. Add 5 drops of acetic acid (1 \rightarrow 3). A light purple color develops.

(2) To 1 ~ 2 drops of α -Ionone, add 2 mL of hydrochloric acid, and shake. The color of the solution becomes to a yellow color. Add 3 drops of chloral hydrate solution (1 \rightarrow 20), and heat in a water bath. A red-purple color develops.

Purity (1) Specific Gravity : Specific gravity of α -Ionone should be within a range of 0.927 ~ 0.933.

(2) Refractive Index : Refractive Index n_D^{20} of α -Ionone should be within a range of 1.497 ~ 1.502.

(3) Clarity and Color of Solution : When 1g of α -Ionone is dissolved in 10 mL of 60% ethanol, it should be clear.

Residues on Ignition When thermogravimetric analysis is done with α -Ionone, the amount of residues should not be more than 0.05%.

Assay Accurately weigh about 1.3 g of α -Ionone, and proceed as directed under hydroxyl amine Method 2 in Aldehyde and Ketone Content in Flavoring Substances Tests. In the procedure, boil the mixture for 1 hour.

1 mL of 0.5 N hydrochloric acid = 96.15 mg $C_{13}H_{20}O$

β-Ionone



Chemical Formula: C₁₃H₂₀O

Molecular Weight: 192.30

이명: 4-(2,6,6-Trimethyl-1-cyclohexenyl)- 3-
butene-2one

CAS No.: 14901-07-6

Compositional Specifications of β-Ionone

Content β-Ionone should contain not less than 90.0% of β-ionone (C₁₃H₂₀O).

Description β-Ionone is colorless ~ pale yellow transparent liquid with a characteristic scent.

Identification (1) To 1 drop of β-Ionone, add 1 mL of water shake well, add 2 drops of sodium nitroprusside solution, add 2 drops of sodium hydroxide solution (3→10), and shake. A orange-red color develops. Add 5 drops of acetic acid. The color of the solution becomes light purple.

(2) To 1 ~ 2 drops of β-Ionone, add 2 mL of hydrochloric acid shake well, color becomes yellow, add 3 drops of hydrated chroral solution (1→20), heat in a water bath, color becomes reddish purple.

Purity (1) Specific Gravity : Specific gravity of β-Ionone should be within a range of 0.940~0.947.

(2) Refractive Index : Refractive Index n_D^{20} β-Ionone of should be within a range of 1.517~1.522.

(3) Clarity and Color of Solution : When 1 mL of β-Ionone is dissolved in 4 mL of 70% alcohol, it should be clear.

Residue on Ignition When thermogravimetric analysis is done with β-Ionone, the amount of residues should not be more than 0.05%.

Assay Approximately 1.3 g of β-Ionone is tested by the procedure in Hydroxylamine Method 2 in Aldehyde and Ketone Content Measurement for Flavorings. In this case, it is heated for 1 hour.

$$1 \text{ mL of } 0.5 \text{ N hydrochloric acid} = 96.15 \text{ mg C}_{13}\text{H}_{20}\text{O}$$

Iron Sesquioxide

Chemical Formula: Fe₂O₃

Molecular Weight: 159.69

INS No.: 172(ii)

Synonyms: Iron oxide red

CAS No.: 1309-37-1

Compositional Specifications of Iron Sesquioxide

Content Iron Sesquioxide should contain not less than 98.0% of iron sesquioxide (Fe₂O₃).

Description Iron Sesquioxide occurs as a red to yellow-brown powder.

Identification To 1 g of Iron Sesquioxide, add 3 mL of diluted hydrochloric acid (1→2), and dissolve by heating. The solution responds to the test for Ferric Salt in Identification.

Purity (1) Water Soluble Substances : To 5 g of Iron Sesquioxide, add 200 mL of water, and boil for 5 minutes. After cooling, add water to make 250 mL, and filter. Discard 50 mL of the initial filtrate, measure exactly 100 mL of the subsequent filtrate, and evaporate to dryness on a water bath. Dry the residue at 105 ~ 110°C for 2 hours. The content should not be more than 15 mg.

(2) Arsenic : It should be no more than 2.0 ppm tested by Arsenic Limit Test.

(3) Lead : 0.2 g of Iron Sesquioxide is weighed and transferred into 50 mL flask. Add 10 mL of 9 N hydrochloric acid, 10 mL of water, which is then dissolved by heating and cooled. Add 20 mL of ascorbic acid-sodium iodide solution and 5 mL of trioctyl phosphine oxide solution, and shake it to mix for 30 seconds. Keep it to separate the layer and add water again so that organic layer reaches to neck part of flask. After shaking to mix it, keep it to separate the layer. This organic solvent layer is used as test solution. Separately, take 10 mL of lead standard solution and make it precisely to 100 mL. Accurately take 2 mL of this solution, transfer into 50 mL flask, and operate under condition as test solution method. This solution is used as reference solution. When the test solution and reference solution are tested by Atomic Absorption Spectrophotometry or Inductively Coupled Plasma Emission Spectroscopy, the contents should not be more than 10 ppm.

Ascorbic acid-sodium iodide solution : 10 g of ascorbic acid and 19.3 g sodium iodide are dissolved in water to make to 100 mL.

Trioctyl phosphine oxide solution : 5 g of trioctyl phosphine oxide is dissolved in methyl isobutyl ketone to make to 100 mL.

(4) Cadmium : When Iron Sesquioxide is tested by Atomic Absorption Spectrophotometry or Inductively Coupled Plasma Emission Spectroscopy, its content should not be more than 1.0 ppm.

(5) Mercury : When Iron Sesquioxide is tested by Mercury Limit Test, its content should not be more than 1.0 ppm.

Assay Accurately weigh about 1 g of Iron Sesquioxide, add 30 mL of hydrochloric acid, heat until the insoluble substance becomes almost white, and add water to make about 50 mL. Filter the solution,

and wash the residue on the filter paper with about 50 mL of water. Combine the filtrate and the washings, and add water to make exactly 250 mL. Measure exactly 25 mL of this solution, and evaporate to about 10 mL. Add 5% stannous chloride solution while heating until the solution becomes colorless, add 1 ~ 2 drops of 5% stannous chloride solution, and cool rapidly. Add 10 mL of mercuric chloride saturated solution all at once, add 25 ~ 30 mL of manganese sulfate solution and about 100 mL of water, and titrate with 0.1 N potassium permanganate. Perform a blank test in the same manner, and make any necessary correction.

1 mL of 0.1 N potassium permanganate = 7.985 mg of Fe_2O_3

Iron, Electrolytic

Compositional Specifications of Electrolytic Iron

Content Electrolytic Iron should contain not less than 97.0% of Iron (Fe).

Description Electrolytic Iron is grayish black powder without gloss.

Identification A solution of Electrolytic Iron in dilute sulfuric acid responds to test of ferrous salt in Identification.

Purity (1) Acid Insoluble Substances : When Electrolytic Iron is tested according to Purity (1) for [Reduced Iron], the amount should not be more than 2 mg.

(2) Arsenic : It should be no more than 4.0 ppm tested by Arsenic Limit Test.

(3) Lead : 1.0 g of Electrolytic Iron is weighed and transferred into 50 mL flask. Add 10 mL of 9 N hydrochloric acid, 10 mL of water, 20 mL of ascorbic acid-sodium iodide solution and 5 mL of trioctyl phosphine oxide solution and shake it to mix for 30 seconds. Add keep it to separate the layer and again add water so that organic layer reaches to neck part of flask. After shaking to mix it, keep it to separate the layer. This organic solvent layer is used as test solution. Separately, take 10 mL of lead standard solution and make it precisely to 100 mL. Take 2 mL of this solution and transfer into 50 mL flask. And operate under condition as test solution method, this solution is used as reference solution. When it is tested by Atomic Absorption Spectrophotometry or Inductively Coupled Plasma Emission Spectroscopy, absorbance(luminous intensity) of test solution should not be more than absorbance(luminous intensity) of reference solution.(not be more than 2.0 ppm.)

Ascorbic acid-sodium iodide solution : 10 g of ascorbic acid and 19.3 g sodium iodide are dissolved in water to make to 100 mL.

Trioctyl phosphine oxide solution : 5 g of trioctyl phosphine oxide is dissolved in methyl isobutyl ketone to make to 100 mL.

(4) Mercury : Proceed as directed under Purity (4) in [Reduced Iron]. 2 mL of mercury standard solution(for reduced iron) is taken and processed by the same procedure as the test sample (Not more than 2 ppm).

Assay Proceed as directed under Assay in [Reduced Iron].

Iron, Reduced

[Content Specifications of Reduced Iron

Content Iron, Reduced should contain not less than 96.0% of Iron (Fe).

Description Iron, Reduced is scentless black gray powder without gloss.

Identification A solution of Iron, Reduced in dilute sulfuric acid responds to the test for ferrous reaction in Identification.

Purity (1) Acid Insoluble Substances : 1 g of Iron, Reduced is dissolved in 25 mL of dilute sulfuric acid, which is heated until the evolution of hydrogen gas stops. It is then filtered and the residue is washed with water until the reaction of sulfate salts stops. The residue is heated at 105°C until the weight becomes constant. The amount of the residue should not be more than 12.5 mg.

(2) Arsenic : It should be no more than 8.0 ppm tested by Arsenic Limit Test.

(3) Lead : 1.0 g of Iron, Reduced is weighed and transferred into 50 mL flask. Add 10 mL of 9 N hydrochloric acid, 10 mL of water, 20 mL of ascorbic acid-sodium iodide solution and 5 mL of trioctyl phosphine oxide solution and shake it to mix for 30 seconds. Keep it to separate the layer and again add water so that organic layer reaches to neck part of flask. After shaking to mix it, keep it to separate the layer. This organic solvent layer is used as test solution. Separately, take 10 mL of lead standard solution and make it precisely to 100 mL. Take 2 mL of this solution and transfer into 50 mL flask. And operate under condition as test solution method, this solution is used as reference solution. When it is tested by Atomic Absorption Spectrophotometry or Inductively Coupled Plasma Emission Spectroscopy, absorbance(luminous intensity) of test solution should not be more than absorbance(luminous intensity) of reference solution.(not be more than 10 ppm.)

Ascorbic acid-sodium iodide solution : 10 g of ascorbic acid and 19.3 g sodium iodide are dissolved in water to make to 100 mL.

Trioctyl phosphine oxide solution : 5 g of trioctyl phosphine oxide is dissolved in methyl isobutyl ketone to make to 100 mL.

(4) Mercury : 1 g of Iron, Reduced is dissolved in 30 mL of dilute sulfuric acid and 1mL of potassium permanganate solution (3→50) is added (Test Solution). Hydroxylamine hydrochloride solution (1→5) is added until the purple color of potassium permanganate in the Test Solution disappears and manganese dioxide precipitates disappear. Then water is added to bring the total volume to 100 mL (Test Solution). When the test solution is tested by Hydride Generation-Atomic Absorption Spectrophotometry, its content should not be more than 5.0 ppm.

Assay Approximately 0.2 g of Iron, Reduced, precisely weighed, is transferred into a 300 mL Erlenmeyer flask, and 50 mL of diluted sulfuric acid is added. A Bunsen valve stopper is placed and iron is completely dissolved by heating in a water bath. After cooling, 50 mL of water (freshly boiled and cooled) and 2 drops of o-phenanthroline solution are added, which is then titrated with 0.1 N cerium II sulfate solution until pale blue color appears. Separately, a blank test is carried out following the same procedure.

1 mL of 0.1 N cerium II sulfate = 5.585 mg Fe

Isoamyl Acetate

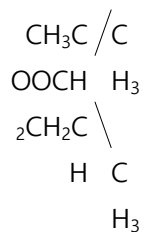

Chemical

Formula:

$\text{C}_7\text{H}_{14}\text{O}_2$

Molecular

Weight: 130.19

Synonyms:

Isopent

yl

acetate

CAS No.:

; β -

123-92-2

Methyl

butyl

acetate

Compositional Specifications of Isoamyl Acetate

Content Isoamyl Acetate should contain not less than 95.0% of isoamyl acetate ($\text{C}_7\text{H}_{14}\text{O}_2$).

Description Isoamyl Acetate is a colorless, transparent liquid having a characteristic odor.

Identification To 1 mL of Isoamyl Acetate, add 5 mL of 10% alcoholic solution of potassium hydroxide and heat in a water bath while shaking. The characteristic odor disappears, and an odor of isoamyl alcohol is evolved. Cool, and add 10 mL of water and 0.5 mL of diluted hydrochloric acid. The solution responds to the test for Acetate (C) in Identification.

Purity (1) Specific Gravity : Specific gravity of Isoamyl Acetate should be within a range of 0.868 ~ 0.878.
(2) Refractive Index : Refractive Index n_D^{20} of Isoamyl Acetate should be within a range of 1.400 ~ 1.404.
(3) Clarity and Color of Solution : When 1 mL of Isoamyl Acetate is dissolved in 3 mL of 60% alcohol, the solution should be clear.
(4) Acid value : Acid value of Isoamyl Acetate is tested by Acid Value in Flavoring Substance Test. The content should not be more than 1.

Assay Accurately weigh about 0.5 g of Isoamyl Acetate, and proceed as directed under Ester Content in

Flavoring Substances Tests.

1 mL of 0.5 N alcoholic solution of potassium hydroxide = 65.09 mg of $C_7H_{14}O_2$

Isoamyl Butyrate

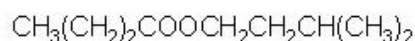

Chemical Formula: $\text{C}_9\text{H}_{18}\text{O}_2$

Molecular Weight: 158.24

Synonyms: 3-Methylbutyl butyrate

CAS No.: 106-27-4

Compositional Specifications of Isoamyl Butyrate

Content Isoamyl Butyrate should contain not less than 98.0% of isoamyl butyrate ($\text{C}_9\text{H}_{18}\text{O}_2$).

Description Isoamyl Butyrate is a colorless to light yellow, transparent liquid having a fruity odor.

Identification To 1 mL of Isoamyl Butyrate, add 5 mL of 10% alcoholic solution of potassium hydroxide. When this solution is shaken and heated in a water bath, its characteristic odor disappears. After cooling, this solution is acidified with dilute sulfuric acid, and an odor of butyric acid is generated.

Purity (1) Specific Gravity : Specific gravity of Isoamyl Butyrate should be within a range of 0.860 ~ 0.864

(2) Refractive Index : Refractive Index n_D^{20} of Isoamyl Butyrate should be within a range of 1.409 ~ 1.414

(3) Clarity and Color of Solution : When 1 mL of Isoamyl Butyrate is dissolved in 4 mL of 70% ethanol, the solution should be clear.

(4) Acid Value : Acid value of Isoamyl Butyrate is tested by Acid Value in Flavoring Substance Test. It should not be more than 1.

Assay Accurately weigh about 0.8 g of Isoamyl Butyrate, and test by Ester Value in Flavoring Substances Test.

1 mL of 0.5 N alcoholic potassium hydroxide = 79.12 mg of $\text{C}_9\text{H}_{18}\text{O}_2$

Isoamyl Formate

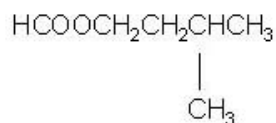

Chemical Formula: C₆H₁₂O₂

Molecular Weight: 116.16

Synonyms: 3-methylbutyl formate

CAS No.: 110-45-2

Compositional Specifications of Isoamyl Formate

Content Isoamyl Formate should contain not less than 92.0% of isoamyl formate (C₆H₁₂O₂).

Description Isoamyl Formate is a colorless, transparent liquid having a characteristic odor.

Identification (1) To 1 mL of Isoamyl Formate, add 10 mL of sodium hydroxide solution, and heat in a water bath for 5 minutes while shaking. The characteristic odor disappears, and the oil phase of the upper layer is evolved an odor of isoamyl alcohol.

(2) To 1 mL of the solution the lower layer obtained in (1) above, add 1.5 mL of diluted hydrochloric acid. and add 20 mg of magnesium dust divided into several portions. After effervescence ceases, add 3 mL of diluted sulfuric acid (3→5) and 10 mg of chromotropic acid, shake, and warm in hot water for 10 minutes. A red-purple color develops.

Purity (1) Specific Gravity : Specific gravity of Isoamyl Formate should be within a range of 0.878 ~ 0.885

(2) Refractive Index : Refractive Index n_D^{20} of Isoamyl Formate should be within a range of 1.396 ~ 1.400

(3) Clarity and Color of Solution : When 1 mL of the solution is dissolved in 4 mL of 70% ethanol, The solution should be clear.

(4) Acid Value : Acid value of Isoamyl Formate is tested by Acid Value in Flavoring Substance Test. It should not be more than 1. In this case, titrate in ice water while cooling, and continue until the light pink color persists for 10 seconds.

Assay Accurately weigh about 1 g of Isoamyl Formate, and test Saponification Value by saponification value measuring method in Flavoring Substances Tests and Acid Value by Purity (4). Calculate the content by the following formula :

$$\text{Content(\%)} = \frac{\text{Saponification value} - \text{Acid value}}{561.1} \times 116.16$$

Isoamyl Isovalerate

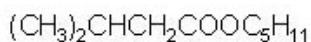

Chemical Formula: $\text{C}_{10}\text{H}_{20}\text{O}_2$

Molecular Weight: 172.27

Synonyms: 3-Methylbutyl 3-methylbutyrate

CAS No.: 659-70-1

Compositional Specifications of Isoamyl Isovalerate

Content Isoamyl Isovalerate should contain not less than 98.0% of isoamyl isovalerate ($\text{C}_{10}\text{H}_{20}\text{O}_2$).

Description Isoamyl Isovalerate is a colorless to light yellow, transparent liquid, It has a chractersitic odor.

Identification To 1 mL of Isoamyl Isovalerate, add 5 mL of 10% alcoholic potassium hydroxide solution, and heat in a water bath while shaking. The characteristic odor disappears, and an odor of isoamyl alcohol is evolved. After cooling, acidify with diluted sulfuric acid. An odor of isovaleric acid is evolved.

Purity (1) Specific Gravity : Specific Gravity of Isoamyl Isovalerate should be within a range of 0.851 ~ 0.857.

(2) Refractive Index : Refractive Index n_D^{20} of Isoamyl Isovalerate should be within a range of 1.411 ~ 1.414.

(3) Clarity and Color of Solution : When 1 mL of Isoamyl Isovalerate is dissolved in 8 mL of 70% alcohol solution, it should be clear.

(4) Acid value : Acid value of Isoamyl Isovalerate is tested by Acid Value in Flavoring Substance Test. It should not be more than 2.

Assay Accurately weigh about 1.5 g of Isoamyl Isovalerate and proceed as directed under Ester Content in Flavoring Substances Tests.

1 mL of 0.5 N ethanolic potassium hydroxide = 86.13 mg of $\text{C}_{10}\text{H}_{20}\text{O}_2$.

Isoamyl Propionate

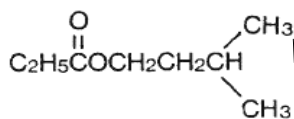

Chemical Formula: C₈H₁₆O₂

Molecular Weight: 144.22

Synonyms: 3-Methylbutyl propionate; Isopentyl propionate; Isoamyl propanoate

CAS No.: 105-68-0

Compositional Specifications of Isoamyl Propionate

Content Isoamyl Propionate should contain not less than 98.0% of isoamyl propionate (C₈H₁₆O₂).

Description Isoamyl Propionate is a colorless to light yellow, transparent liquid having a characteristic odor.

Identification To 1 mL of Isoamyl Propionate, add 5 mL of ethanolic 10% potassium hydroxide solution, and heat in a water bath while shaking. The characteristic odor disappears, and an odor of isoamyl alcohol is evolved. Cool, and acidify with diluted sulfuric acid. An odor of propionic acid is evolved.

Purity (1) Specific Gravity : Specific gravity of Isoamyl Propionate should be within a range of 0.868 ~ 0.872.

(2) Refractive Index : Refractive Index n_D^{20} of Isoamyl Propionate should be within a range of 1.404 ~ 1.408.

(3) Clarity and Color of Solution : 1 mL of Isoamyl Propionate is dissolved in 4 mL of 70% ethanol. This solution should be Clear.

(4) Acid value : Acid value of Isoamyl Propionate is tested by Acid Value in Flavoring Substance Test. It should not be more than 1.

Assay Accurately weigh about 0.7 g of Isoamyl Propionate, and proceed as directed under Ester Content in Flavoring Substances Tests.

1 mL of 0.5 N alcoholic solution of potassium hydroxide = 72.11 mg of C₈H₁₆O₂

Isobutyl Phenylacetate



Chemical Formula: C₁₂H₁₆O₂

Molecular Weight: 192.23

Synonyms: Isobutyl alpha-toluate

CAS No.: 102-13-6

Compositional Specifications of Isobutyl Phenylacetate

Content Isobutyl phenylacetate should contain not less than 98.0% of isobutyl phenylacetate (C₁₂H₁₆O₂).

Description Isobutyl phenylacetate is a colorless, transparent liquid having a characteristic odor.

Identification (1) To 2 mL of Isobutyl Phenylacetate, add 10 mL of 10% alcoholic solution of potassium hydroxide, equip with a reflux condenser, and boil gently in a water bath for 1 hour. Add 10 mL of water, distill, and take about 1.5 mL of the initial distillate. The solution is clear, and an odor of isobutanol is generated.

(2) Acidify the residual solution in (1) with diluted hydrochloric acid. Crystals are deposited. Collect the crystals by filtration, wash with water, and recrystallize from boiling water. The melting point is 76°C.

Purity (1) Specific Gravity : Specific gravity of Isobutyl Phenylacetate should be within a range of 0.984 ~ 0.988.

(2) Refractive Index : Refractive Index n_D^{20} of Isobutyl Phenylacetate should be within a range of 1.486 ~ 1.488.

(3) Clarity and Color of Solution : When 1 mL of Isobutyl Phenylacetate is dissolved in 3 mL of 80% alcohol, the solution should be clear.

(4) Acid Value : Acid value of Isobutyl Phenylacetate is proceeded as directed under Acid Value in Flavoring Substance Test. It should not be more than 1.

(5) Chlorinated Compounds : When Isobutyl Phenylacetate is proceeded as directed under Copper Mesh Test Method in Halogenated Compounds for Flavoring, it should be appropriate.

Assay Accurately weigh about 1.5 g of Isobutyl Phenylacetate and proceed as directed under Ester Content in Flavoring Substances Tests.

1 mL of 0.5 N alcoholic solution of potassium hydroxide = 96.13 mg of C₁₂H₁₆O₂

Isoeugenol



Chemical Formula: $C_{10}H_{12}O_2$

Molecular Weight: 164.20

Other names: 2-Methoxy-4-propylphenol

CAS No.: 97-54-1

Compositional Specifications of Isoeugenol

Content Isoeugenol should contain not less than 99.0% of isoeugenol ($C_{10}H_{12}O_2$).

Description Isoeugenol is a colorless to light yellow-brown, transparent liquid having a characteristic odor.

Identification (1) 5 drops of Isoeugenol is dissolved in 10 mL of alcohol. When 3 drops of ferrous chloride solution are added to this solution, a green color appears.

(2) To 0.5 g of Isoeugenol, add 0.1 g of picric acid, 1 mL of acetone, and 9 mL of petroleum ether. When it is heated in a water bath until crystals dissolve, the solution becomes reddish brown.

Purity (1) Specific Gravity : Specific gravity of Isoeugenol should be within a range of 1.079 ~ 1.08.

(2) Refractive Index : Refractive Index n_D^{20} of Isoeugenol should be within a range of 1.572 ~ 1.577.

(3) Clarity and Color of Solution : When 1 mL of Isoeugenol is dissolved in 5 mL of 50% alcohol, it should be clear.

Assay Proceed as directed under Phenol Content in Flavoring Substances Tests. Instead of allowing to stand for 30 minutes, heat in a water bath for 30 minutes, and allow to cool to room temperature.

L-Isoleucine

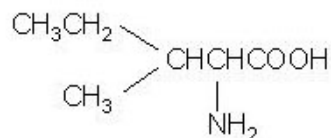

Chemical Formula: C₆H₁₃O₂N

Molecular Weight: 131.17

Synonyms: L-2-Amino-3-methylvaleric acid

CAS No.: 73-32-5

Compositional Specifications of L-Isoleucine

Content L-Isoleucine, when calculated on the dried basis, should contain within a range of 98.0 ~ 102.0% of L-isoleucine (C₆H₁₃NO₂).

Description L-Isoleucine occurs as white crystals or as a crystalline powder. It is odorless and has a lightly bitter taste.

Identification (1) A solution of L-Isoleucine in 6 N hydrochloric acid (1→25) is dextrorotatory (D-form).
(2) To 5 mL of L-Isoleucine solution (1→1,000), add 1 mL of ninhydrin solution, and heat for 3 minutes. The color becomes reddish purple ~ bluish purple.

Purity (1) Clarity and Color of Solution : 0.5 g of L-Isoleucine is dissolved in 20 mL of water. It is colorless and should not be more than almost clear.

(2) pH : pH of L-Isoleucine solution(1→100), measured should be within a range of 5.5 ~ 7.0.

(3) Specific Rotation : Dissolve 2 g of L-Isoleucine, precisely weighed and accurately dried, in 50 mL of 6 N hydrochloric acid. Optical rotation of this solution should be within a range of $[\alpha]_D^{20} = +39.5 \sim +41.5^\circ$.

(4) Arsenic : It should be no more than 4.0 ppm tested by Arsenic Limit Test.

(5) Lead : When 5.0 g of L-Isoleucine is tested by Atomic Absorption Spectrophotometry or Inductively Coupled Plasma Emission Spectroscopy, its content should not be more than 5.0 ppm.

(6) Chloride : When 0.5 g of L-Isoleucine is tested by Chloride Limit Test, its content should not be more than the amount that corresponds to 0.3 mL of 0.01 N hydrochloric acid.

Loss on Drying When L-Isoleucine is dried for 3 hours at 105°C, the weight loss should not be more than 0.3%.

Residue on Ignition Residue on ignition of L-Isoleucine should not be more than 0.1%.

Assay Approximately 0.3 g of L-Isoleucine is dissolved in 50 mL of glacial acetic acid by heating. After cooling, the solution is titrated with 0.1 N perchloric acid solution (indicator : 10 drops of α -naphtholbenzein solution). End point is where the brown color of the solution changes to green.

1 mL of 0.1 N perchloric acid = 13.12 mg of $C_6H_{13}NO_2$

Isomalt

Hydrogenated palatinose : Isomaltitol

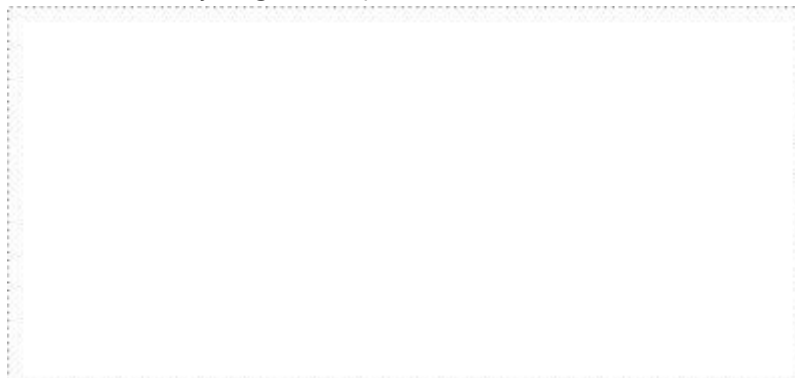

Chemical Formula: GPS $C_{12}H_{24}O_{11}$

GPM $C_{12}H_{24}O_{11} \cdot 2H_2O$

Molecular Weight: GPS 344.32

GPM 380.32

INS No.: 953

Synonyms: Hydrogenated palatinose; Isomaltitol

CAS No.: 64519-82-0

Compositional Specifications of Isomalt

Content Isomalt should contain not less than 98.0% as anhydrous isomalt. The sum of contents (α -D-Glucopyranosyl-1,6-D-Sorbitol (GPS, $C_{12}H_{24}O_{11}$) and α -D-Glucopyranosyl-1,1-D-Mannitol 2 hydrate[GPM, $C_{12}H_{24}O_{11} \cdot 2H_2O$]) should not be less than 86.0%.

Description Isomalt is slightly hygroscopic scentless white crystallite with sweet taste.

Identification (1) Isomalt is soluble in water but insoluble in alcohol.

(2) 500 mg of Isomalt is dissolved in 100 mL of water to make the test solution. 0.3 μ l of test solution and 0.3 μ l of the reference solution are tested using thin layer chromatography. However, in the thin layer, silica gel is used as the carrier. When the elution solution reaches about 10 cm up, elution is stopped and the layer is dried with wind and then chromagen 1 is sprayed on the layer. To dry, the layer transfer into air for 15 mins and again chromagen 2 is sprayed for comparative observation, spots should appear almost in the same locations, colors, and sizes as in the reference solution.

• Reference solution : 500 mg of sorbitol, mannitol, lactitol, maltitol, -D-glucopyranosil-1,1-D-mannitol ($2H_2O$), and -D-glucopyranosil-1,6- sorbitol are respectively dissolved in 100 mL of water.

• Developing solvent

① Isopropanol : n-Butanol : Boric Acid (2.5 \rightarrow 100) : Acetic Acid : Propionic Acid (50 : 30 : 20 : 2 : 16)

② Ethylacetate : Pyridin : Water : Acetic Acid : Propionic Acid

(50 : 50 : 10 : 5 : 5)

• Chromagen

① 0.1% sodium metaperiodate

② Ethyl Alcohol: Sulfuric Acid: Anisaldehyde: Acetic Acid (90: 5: 1: 1)

- Purity** (1) Reducing Material : Transfer 7 g (converted to a dehydrated form) of Isomalt transfer into a 400 mL beaker, add 35 mL of water and shake. 50 mL of Fehling solution is added and the beaker is covered with a watch glass. The mixture is heated so that it boils within 4 minutes. After boiling exactly for 2 minutes, precipitated cupric oxide (Cu_2O) is filtered through a glass filter. Precipitates are sequentially rinsed with hot water, alcohol, and ether. It is then dried for 30 minutes at 100°C . Cupric oxide on the filter is again washed thoroughly with 10 mL of hot water, 10 mL of alcohol, and 10 mL of ether. After drying for 1 hour at 100°C , the weight of cupric oxide should not be more than 50 mg.
- (2) D-Mannitol : 10 g of Isomalt is precisely weighed and quantitatively tested for D-mannitol. The amount of D-mannitol should not be more than 3.0 %. Standard solution is prepared by dissolving precisely weighed 50 mg of standard D-mannitol in water to make 100 mL.
- (3) D-Sorbitol : 10 g of Isomalt is precisely weighed and quantitatively tested for D-mannitol. The amount of D-mannitol should not be more than 6.0%. Standard solution is prepared by dissolving precisely weighed 50 mg of standard D-sorbitol in water to make 100 mL.
- (4) Arsenic : It should be no more than 4.0 ppm tested by Arsenic Limit Test.
- (5) Lead : When 5.0 g of Isomalt is tested by Atomic Absorption Spectrophotometry or Inductively Coupled Plasma Emission Spectroscopy, its content should not be more than 1.0 ppm.
- (6) Nickel : 10 g of Isomalt is weighed and transferred into a flask for decomposition. 50 ~ 70 mL of water and 30 mL of nitric acid are added to the flask and set-aside. It is then gently heated until the violent reaction is completed. After cooling the flask, 10 mL of sulfuric acid is added and the flask is gently heated again. When the content darkens, 2 ~ 3 mL of nitric acid is added at a time while continuously heating. The decomposition is complete when the content is pale yellow ~ colorless. After cooling the liquid, 30 mL of water and 15 mL of saturated ammonium hydroxide solution are added to the flask, which is then heated until white smoke of sulfuric acid is generated. This is then cooled and water is added to bring the total volume to 100 mL. Use this solution as the test solution. 10 mL of test solution is transferred into an extraction bottle. At the same time, a blank test is carried out with the Test Solution. Separately, 1 mL of nickel standard solution (2 ppm) transfer into an extraction bottle and a blank test is carried out with this Standard Solution. 10 mL of 25% ammonium citrate solution and 2 drops bromothymol blue solution are added to each Test Solution and Standard Solution. The resulting solution is titrated with ammonium solution until the color of the solution turn green from yellow. Then 10 mL of 40% ammonium sulfate solution and water is added to bring the total volume to 100 mL. 10 mL of sodium diethyldithiocarbamate solution is added, shaken vigorously, and set-aside for few minutes. 10 mL of methyl isobutylketone is added to this Test Solution as well

as its blank test solution, standard solution, and its blank test solution, respectively. Each is shaken vigorously. After settling, ethyl isobutyl ketone layer is separated out from each bottle and analyzed with atomic absorption spectrometry or inductively coupled plasma method. The absorption (or peak height) of Test Solution should not be higher than that of the Standard Solution (not more than 2 ppm).

Water Content Isomalt is well ground with a mortar and a pestle, which is then sieved. It is then analyzed for water content (Karl-Fisher Method). The content of water should not be more than 7%.

Residue on Ignition When thermogravimetric analysis is done with precisely weighed 5 g of Isomalt, the amount of residue should not be more than 0.05%.

Assay 1 g of Isomalt is dissolved in 100 mL water. Use this solution as the test solution. Separately, 100 mL solution each containing 0.8 g of GMP standard and 0.883 g of GPS standard is prepared, respectively (Standard Solution). 25 µl of each Standard Solution and Test Solution is injected into liquid chromatography equipment following the operation conditions below. The contents of GMP and GPS are calculated using the following equations.

$$\text{GPM}(\%) = \frac{\text{Peak area of test solution}}{\text{Peak area of standard solution}} \times \frac{\text{weight of the standard(GPM)}}{\text{weight of the sample(g)}} \times 100$$

$$\text{GPS}(\%) = \frac{\text{Peak area of test solution}}{\text{Peak area of standard solution}} \times \frac{\text{weight of the standard(GPS)}}{\text{weight of the sample(g)}} \times 100$$

Operation Conditions

- Detector : Differential refractometer (RI Detector)
- Column : Aminex HPX 87C or its equivalent, 7.8mm × 300 mm stainless steel tube
- Column Temperature : 60°C
- Mobile Phase : Water
- Flow Rate : 0.6 mL/min

Isopropyl Alcohol

2-Propanol

Isopropanol

Chemical Formula: C₃H₈O

Molecular Weight: 60.10

Synonyms: 2-Propanol; Isopropanol

CAS No.: 67-63-0

Compositional Specifications of Isopropyl Alcohol

Content Isopropyl Alcohol should contain not less than 99.7% of isopropyl alcohol (C₃H₈O).

Description Isopropyl Alcohol is colorless transparent flammable liquid with a characteristic scent and slightly bitter taste.

Identification 3 mL of water and 1 mL of mercury (II) sulfate solution are added to 2 mL of Isopropyl Alcohol. When the solution is warmed, white ~ yellow precipitates are formed.

Purity (1) Solubility : 10 mL of Isopropyl Alcohol is mixed with 40 mL of water. This solution should be as clear as the same amount of water after 1 hour.

(2) Acid Value (as acetic acid) : 2 drops of phenolphthalein is added to 100 mL of water, where 0.01 N sodium hydroxide solution is added until pale red color persists for 30 seconds. Then 50 mL (approximately 39 g) of Isopropyl Alcohol is added and mixed with the above solution. The resulting solution is titrated with 0.01 N sodium hydroxide solution until pale red color reappears. The consumption of 0.01 N sodium hydroxide solution should not be more than 0.7 mL.

(3) Lead : When 5.0 g of Isopropyl Alcohol is tested by Atomic Absorption Spectrophotometry or Inductively Coupled Plasma Emission Spectroscopy, its content should not be more than 1 ppm.

(4) Distillation Range : When Isopropyl Alcohol is tested for boiling point and amount of distillate, 95%(v/v) or more should be extracted at 81.3~83.3°C.

(5) Residue on Evaporations : 125 mL (approximately 100 g) of Isopropyl Alcohol is dried in a water bath and is further dried for 30 minutes at 105°C. The weight of the residue after cooling should not be more than 10 ppm.

(6) Matters that reduce permanganates : 50 mL of Isopropyl Alcohol transfer into a 50 mL cylinder with a stopper. After adding 0.25 mL of 0.1 N potassium permanganate solution, it is set aside for 10 minutes. Pale red color should not disappear completely.

(7) Specific Gravity : Specific gravity of Isopropyl Alcohol should be within a range of 0.784~0.788

(8) Refractive Index : Refractive Index n_D^{20} of Isopropyl Alcohol should be within a range of 1.374~1.380

Water Content Water content of Isopropyl Alcohol is determined by water determination (Karl-Fisher Method) and should not be more than 0.2%.

Assay Approximately 500 mg of Isopropyl Alcohol is precisely weighed and 50 mL of water is added. 10 mL of this solution is diluted to 100 mL with water (Test Stock Solution). Separately, 500 mg of isopropyl alcohol standard is precisely weighed and diluted as the Test Solution (Standard Stock Solution). 4 mL each of Test Stock Solution and Standard Stock Solution is taken into 100 mL volumetric flask. 4 mL of internal standard solution (Approximately 500 mg of tert-butyl alcohol is precisely weighed and water is added to bring the total volume to 50 mL. 10 mL of this solution is further diluted to 100 mL with water.) is added to each flask. Then the volume of each flask is brought up to 100 mL with water (Test Solution and Standard Solution). 1 μl of each Test Solution and Standard Solution is injected into gas chromatography, and the content (%) of isopropyl alcohol is obtained from the following equation.

$$\text{Content of isopropyl alcohol(\%)} = \frac{W_s \times R_u}{W_u \times R_s} \times 100$$

W_s : Weight of isopropyl alcohol standard (mg)

W_u : Weight of sample (mg)

R_u : Ratio of isopropyl alcohol peak against tert-butyl alcohol peak in Test Solution

R_s : Ratio of isopropyl alcohol peak against tert-butyl alcohol peak in Standard Solution

Operation Conditions

- Column : A glass or stainless tube with inner diameter of 2 mm and length of 2 m
- Column Filler : Chromosorb W-HP coated with 3% OV - 225
- Detector : Hydrogen Flame Ionization Detector (FID)
- Temperature at injection hole: 250°C
- Column Temperature : 200°C
- Detector Temperature : 250°C
- Carrier gas and flow rate : Nitrogen, 30 mL per minute

Itaconic Acid

Compositional Specifications of Itaconic Acid

Content Itaconic Acid, when calculated on the dried basis, should contain not less than 98.0% of itaconic acid ($C_5H_6O_4 = 130.10$).

Description Itaconic Acid is scentless colorless transparent crystal, granule, lump, or white crystalline powder or powder. It has an acidic taste.

Identification (1) Itaconic Acid solution (1→20) is acidic.

(2) To 0.05 g of Itaconic Acid add 0.01 N of sulfuric acid to make 100 mL. Separately, 100 mL of Standard Solution is prepared by adding 0.05 g of itaconic acid in 0.01 N of sulfuric acid. Liquid chromatography is carried out with both solutions under the following operation conditions. Retention time of the main peak of Test Solution should be identical to that of Standard Solution.

Operation Conditions

-Detector : UV absorption photometer (measured at wavelength 210 nm) -Column Filler : Sulfonated polystyrene gel with 6 μ m particle diameter

-Column Tube : Stainless steel tube (SUS316) with 8 mm inner diameter, 30 cm length

-Column Temperature : 60°C

-Mobile Phase : 0.01 N Sulfuric acid

-Flow Rate : 1 mL/min

-Amount of solution injected : 20 μ l

Purity (1) Chloride : 0.5 g of Itaconic Acid is tested by Chloride Limit Test. The content should not be more than the amount that correspond to 0.1 mL of 0.01 N hydrochloric acid.

(2) Sulfate : 0.5 g of Itaconic Acid is dissolved in 30 mL of water and 2 mL of dilute hydrochloric acid by boiling for 1 minute. After cooling, the solution is tested by Sulfate Limit Test. The content should not be more than amount that correspond to 0.1 mL of 0.01 N hydrochloric acid.

(3) Arsenic : It should be no more than 4.0 ppm tested by Arsenic Limit Test.

(4) Lead : When 5.0 g of Itaconic Acid is tested by Atomic Absorption Spectrophotometry or Inductively Coupled Plasma Emission Spectroscopy, its content should not be more than 2.0 ppm.

Loss on Drying When 2 g of Itaconic Acid is dried for 2 hours at 100°C, the loss should not be more than 0.5%.

Residue on Ignition When thermogravimetric analysis is done with 2 g of Itaconic Acid, the amount of residue should not be more than 0.1%.

Assay 2 g of Itaconic Acid, precisely weighed, add water to make 250 mL. Take 25 mL of this solution and titrate with 0.1 N sodium hydroxide solution (indicator : 2 ~ 3 drops of phenolphthalein).

1 mL of 0.1 N sodium hydroxide solution = 6.505 mg $C_5H_6O_4$

Kaoliang Color

Definition Kaoliang Color is obtained by extracting kaoliang grains of rice family (*Sorghum nervosum* BESS.) with water or ethyl alcohol. Major colorant is apigenin and luteolinidine. Dilutant, stabilizer, or solvent can be added for the purpose of color value adjustment and quality preservation.

Compositional Specifications of Kaoliang Color

Content Color value of Kaoliang Color ($E_{1cm}^{10\%}$) should be more than the indicated value.

Description Kaoliang Color is brown liquid, lump, powder, or paste with a slight characteristic scent.

Identification (1) Test Solution obtained in Color Value of Kaoliang Color shows yellowish brown ~ reddish brown color. Visible absorption spectrum shows a gentle descending slope from short wavelength to long wavelength.

(2) When Test Solution in Identification (1) is acidified with hydrochloric acid, brown precipitates are formed.

(3) When ferric chloride TS is added to Test Solution in Identification (1), milky white precipitates are formed.

Purity (1) Arsenic : It should be no more than 4.0 ppm tested by Arsenic Limit Test.

(2) Lead : When 5.0 g of Persimmon Color is tested by Atomic Absorption Spectrophotometry or Inductively Coupled Plasma Emission Spectroscopy, its content should not be more than 10.0 ppm.

Assay(Color value) Appropriate amount of Kaoliang Color is accurately weighed so that the absorbance to be measured will be within a range of 0.3 ~ 0.7 and dissolved in 30 mL of sodium carbonate solution (1→100). Citric acid-dibasic sodium phosphate buffer solution with pH 7.0 is added so that the total volume is to make 100 mL. Take 1 mL of this solution, add citric acid-dibasic sodium phosphate buffer solution with pH 7.0, and make to volume 100 mL and this is used as the Test Solution. If necessary, the solution is centrifuged and the supernatant is used. Using citric acid-dibasic sodium phosphate buffer solution with pH 7.0 as a reference solution, absorption A is measured at 500 nm wavelength with 1cm path length. Color value is obtained using the following equation.

$$\text{Color Value}(\overset{10\%}{E}_{1cm}) = \frac{A \times 1,000}{\text{weight of the sample(g)}}$$

Citric acid-dibasic sodium phosphate buffer solution (pH 7.0)

•Solution 1 : 0.1 M citric acid solution : 1L of solution containing 21.01 g of citric acid ($C_6H_8O_7 \cdot H_2O$).

•Solution 2 : 0.2 M dibasic sodium phosphate solution : 1 L of solution containing 71.63 g of dibasic sodium phosphate ($Na_2HPO_4 \cdot 12H_2O$).

Solution 1 and Solution 2 are mixed well (35:165) and its pH is adjusted to 7.0.

Kaolin

INS No.: 559

CAS No.: 1332-58-7

Definition Kaolin is obtained from kaolin and its major constituent is hydrated aluminum silicate.

Compositional Specifications of Kaolin

Description Kaolin is white or milky white powder.

Identification (1) 0.2 g of Kaolin is mixed with 0.5 g of mixture(1:1) of anhydrous sodium carbonate and anhydrous potassium carbonate. It is then heated until it melts completely in a platinum or nickel crucible. After cooling, 5 mL of water is added and allow to stand for 3 minutes. The bottom of the crucible is gently heated and then the solidified matter is transferred into a beaker together with water. Hydrochloric acid is slowly added until foaming stops. After adding 10 mL more of hydrochloric acid, it is evaporated to dryness in a water bath. 200 mL of water is added to the residue, which is boiled and filtered. Gel phase residue is transferred into a platinum crucible. When 5 mL of hydrofluoric acid is added, it is dissolved. Upon heating, it almost completely evaporated.

(2) The filtrate obtained by (1) responds to all tests for Aluminum Salt in the Identification.

(3) 5 mL of water is added to 8 g of Kaolin, and mix well. It becomes plastic.

Purity (1) Water Solubles and pH : 10 g of Kaolin is added to 100 mL of water. It is then boiled for 30 minutes while supplementing water for the loss. After cooling, water is added to bring the total volume to 100 mL, which is filtered using a glass filter (3G4). pH of the filtrate should be 6.0~8.0. 50 mL of the filtrate is evaporated to dryness, which is then dried for 1 hour at 105°C. The resultant residue should not be more than 15 mg.

(2) Acid Solubles : 20 mL of diluted sulfuric acid (1→15) is added to 1 g of Kaolin, is mixed with shaking for 15 minutes, which is then filtered. 10 mL of the filtrate is evaporated to dryness and is ignited to constant weight. The residue should not be more than 10 mg .

(3) Arsenic : It should be no more than 4.0 ppm tested by Arsenic Limit Test.

(4) Lead : When 5.0 g of Kaolin is tested by Atomic Absorption Spectrophotometry or Inductively Coupled Plasma Emission Spectroscopy, its content should not be more than 10.0 ppm.

(5) Foreign matter : 5 g of Kaolin is mixed in 300 mL of water by stirring, which is allowed to stand for 30 seconds. Most of the solution containing the fine particles is discarded by decantation the container. When the portion remaining at the bottom of the container is pressed using a glass rod with a flat end, there is no audible sound produced by the sand.

Loss on Ignition When the Loss on Ignition analysis is done, the weight loss should not be more than 15%.

Karaya Gum

Sterculia Gum

INS No.: 416

Synonyms: *Sterculia* gum; Katilo; Kaday; Kullo;
Kuterra

CAS No.: 9000-36-6

Definition Karaya Gum is obtained by drying gummy secretion of *Sterculia urens Roxburgh*, *Sterculia* (Fam. *Sterculiaceae*) and its variety, *Cochlospermum Gossypium A. P. De Condolle*, or *Cochlospermum Kunth* (Fam. *Bixaceae*). It is a polysaccharide consisting mainly of galactose, rhamnose, and galacturonic acid.

Compositional Specifications of Karaya Gum

Description Karaya Gum is orange yellow ~ pale reddish brown lump or gray ~ pale reddish brown gray powder having a little odor of acetic acid.

Identification (1) When 2 g powder of Karaya Gum is mixed well with 50 mL of water, it becomes gluey and weakly acidic.

(2) When 0.4 g powder of Karaya Gum is mixed well with 10 mL of 60% alcohol, it swells.

(3) 1 g of Karaya Gum is added to 20 mL of water. Homogeneous mucilage is obtained by heating. After adding 5 mL of hydrochloric acid is added to the glue, it is boiled for 5 minutes. The resulting liquid becomes permanent pale red ~ pale reddish brown.

Purity (1) Arsenic : It should be no more than 4.0 ppm tested by Arsenic Limit Test.

(2) Lead : When 5.0 g of Karaya Gum is tested by Atomic Absorption Spectrophotometry or Inductively Coupled Plasma Emission Spectroscopy, its content should not be more than 2.0 ppm.

(3) Cadmium : When 5.0 g of Karaya Gum is tested by Atomic Absorption Spectrophotometry or Inductively Coupled Plasma Emission Spectroscopy, its content should not be more than 1.0 ppm.

(4) Mercury : When 0.1 g of Karaya Gum is tested by Mercury Test Method, its content should not be more than 1.0ppm.

(5) Acid Insoluble Ash : 3 g of Karaya Gum is carbonized at 550~600°C and reduced to ash by further heating. The resulting ash are boiled for 5 minutes in 25 mL of dilute hydrochloric acid, which is filtered through an ashless filter paper. The residue on the filter paper is washed with a small amount of hot water. It is then carbonized to ash along with the filter paper in a crucible (previously weighed). The content of ash should not be more than 1%.

(6) Insoluble matter : 5 g of Karaya Gum is precisely weighed into a 250 mL Erlenmeyer flask, where a 1:1 mixture of dilute hydrochloric acid and water. It is covered with a watch glass and boiled until the liquid is no longer viscous. The resulting liquid is filtered through a glass filter (previously weighed), which is washed with hot water until the washings are free from acid(pH paper). It is then heated at 105°C and weighed. The content of residues should not be more than 3%.

(7) Starch : 0.1 g of Karaya Gum is dissolved in 100 mL of water by boiling, which is then cooled. When 2 ~ 3 drops of iodine solution are added, it should produced turn blue.

(8) Other Gums : Karaya Gum swells in 60% alcohol.

(9) Volatile Acidity : 1g of Karaya Gum is precisely weighed into a flask, 100 mL of freshly boiled and cooled water and 5 mL of phosphoric acid are added, and allowed to stand for several times until the gum is completely swollen. Under a reflux condenser, boil for 2 hours, steam-distilled until 800 mL of distillate. Use 20 mL of this solution as an indicator, titrate with 0.1N sodium hydroxide, the amount required for neutralizing should not less than 0.42 mL. (not less than 10% as acetic acid). Separately, perform a blank test.

(10) E. Coli : When Karaya Gum is tested by Microbe Test Methods for E. Coli in General Test Method 「Standards and Specifications for Foods」, it should be negative (-).

(11) Salmonella : When Karaya Gum is tested by Microbe Test Methods for Salmonella in General Test Method 「Standards and Specifications for Foods」, it should be negative (-).

Loss on Drying Powder of Karaya Gum is sieved through a No.40 mesh screen. 3 g of sieved powder is dried for 5 hours at 105°C. The weight loss on drying should not be more than 20%.

Viscosity 4 g of Karaya Gum, fine powder, is placed in a container for stirrer. 10 mL of alcohol is added to wet the powder uniformly. After adding 390 mL of water, it is stirred for 7 minutes at 1,000 rpm. The suspension is transferred into a 500 mL bottle and maintained for 12 hours in a water bath at 25°C. Viscosity is measured using LVF Brookfield viscometer with an appropriate set of conditions such as spindle, rpm, factor, etc. The viscosity should be higher than the indicated value or fall within the indicated range of values.

Koji

Definition There are mold bran(nuruk), granular koji, coenzyme, and purified enzyme. mold bran(nuruk) contains enzymes produced by naturally breeding fungus, yeast, and other microbes of *Aspergillus* genus and *Rhizopus* genus in food-grade raw grains. Granular koji contains enzymes produced by breeding fungus of *Aspergillus* genus and *Rhizopus* genus on steamed food-grade grains. Coenzymes are obtained from cultures of enzyme (germs, which produces 'saccharifying enzyme') in steamed or pasteurized material that contains food-grade cortex or starch. Purified enzyme is purified enzyme (by separation) obtained by culturing in solid or liquid culture medium used edible carbohydrate. Dilutant or stabilizer can be added for the purpose of activity adjustment and quality preservation.

Compositional Specifications of Koji

Content When Koji is analyzed quantitatively, as saccharogenic power(SP), nuruk, granular koji, coenzyme, liquid phase purified enzyme (liquid), and purified enzyme (powder) contains 300 SP, 60 SP, 600 SP, 10,000 SP, 15,000 SP, respectively.

Description Koji is yellow ~ yellowish gray or white ~ pale yellow ~ brown liquid, lump, or powder with a slight characteristic scent.

Purity (1) Arsenic : It should be no more than 4.0 ppm tested by Arsenic Limit Test.

(2) Lead : When 5.0 g of Koji is tested by Atomic Absorption Spectrophotometry or Inductively Coupled Plasma Emission Spectroscopy, its content should not be more than 2.0 ppm.

(3) Various Germs (*Penicillium* Genus) : 0.15~0.2 g of Koji is placed in a pre-pasteurized culture medium (55 mL of water, 0.025 g of potassium phosphate, monobasic, and 1 g of dextrin are added in a 300 mL Erlenmeyer flask, which is then plugged with cotton and pasteurized for 20 minutes under 15 psi) and cultured for 5 days at 30°C in a thermostat. When it is observed with a microscope, it should be negative for various germs (*penicillium* genus). For the confirm on *Penicillium* genus, after culturing for 5 days in a 30°C in a thermostat, if *Penicillia* are observed, it is positive. If *Penicillia* are not observed, it cultured for another 24 hours. If *Penicillia* are observed, it is positive. If not, it is negative. (In the case, this applies to granular koji only.)

~~(4) Acid value : 20 g of Koji is leached in 100 mL of water for 3 hours at 30°C, which is then filtered. 2 ~ 3 drops of mixed indicator are added to 10 mL of the filtrate, which is titrated with 0.1 N sodium hydroxide solution until the solution becomes from pink to pale blue. Acid value is calculated by the following equation and should be more than 5.0. (In the case, this applies to granular koji only).~~

$$\text{Acid value} = a \times f$$

~~a : Consumption of 0.1 N sodium hydroxide solution (mL)~~

~~f : Factor of 0.1 N sodium hydroxide solution~~

~~Mixed indicator : 0.2 g of bromothymol blue and 0.1g of neutral red are dissolved in 300 mL of alcohol.~~

Loss on Drying When 10 g of Koji is dried for 4 hours at 105°C, the weight loss should not be more than 12% for nuruk, should not be more than 30% for granular koji, should not be more than 10% for coenzyme, and should not be more than 8% for purified enzyme (not applicable for liquid phase).

Assay (Saccharogenic Power)

Analysis Principle : This test method is based on measuring the amount of reducing sugar produced by decomposition of soluble starch under a set of conditions of time, temperature, pH, and concentration.

Preparation of Test Solution

- Nuruk, granular koji, coenzyme : Test Solution is prepared so that 1 mL of the final dilution contains 1~2SP. Sample is accurately weighed into a Erlenmeyer flask (for nuruk, it is ground to 80~100mesh before weighing), which is isothermalized at 30°C. 200 mL of 1% sodium chloride solution is added to the flask, which is leached for 3 hours at 30°C while stirring gently in a 20 minute interval. It is then filtered and used as Test Solution.
- Purified enzyme : Test Solution is prepared so that 1 mL of the final dilution contains 1~2 SP.

Test Procedure

- ① Production of Reducing Sugar : 50 mL of substrate solution and 30 mL of acetate buffer solution(pH 5.0) are placed in a 100 mL volumetric flask, which is allow to stand for 10 minutes in a 55°C water bath. 10 mL of Test Solution is added to this solution and it is timed. The content is well mixed by shaking and it is allow to stand in the water bath. After exactly 60 minutes, the reaction is stopped by adding 10 mL of 0.5 N sodium hydroxide solution. It is then cooled to room temperature in running water. Water is added to make the total volume to 100 mL. 10 mL each of this solution and the reference is tested for the amount of reducing sugar. Reference solution is prepared by following the same procedure as Test Solution with 10 mL of water instead of 10 mL of Test Solution.
- ② Measurement of Reducing Sugar : 10 mL of fehling solution is added to a 250 mL Erlenmeyer flask, where 40 mL of water, 10 mL of the above solution obtained by production of reducing sugar, and 10 mL of glucose standard solution are added. The mixture is mixed with shaking gently. It is then boiled for 1 minute. While continuously boiling, it is titrated with glucose standard solution. If the blue color of copper sulfate almost disappears, 4 ~ 5 drops of methylene blue TS are added and the titration is continued. The end point is where the color of methylene blue disappears and the consumed amount of glucose standard solution is S (mL). Separately, a blank test is carried out with 10 mL of Fehling solution, 40 mL of water, 10 mL of reference solution, and 10 mL of glucose standard solution. The consumed amount (mL) of glucose standard solution is B (approximately 25 mL is consumed for a blank test).
- ③ Calculation of Saccharogenic Power

$$SP = \frac{(B-S) \times 2}{\quad}$$

$$W \times 1$$

2 : Factor of 20/10, which comes from the concentration of glucose standard solution (2 mg/mL) and used amount of standard solution (10 mL).

W : Weight of sample contained in 10 mL of Test Solution (g)

1 : Reaction time (hour)

Definition of Saccharogenic Power : 1 Saccharogenic power(SP) corresponds to production of 10 mg of glucose by 1 g of an enzyme in 1 hour under the test conditions above.

Solution

- 0.2 M Acetate Buffer Solution (pH 5.0) : 0.2 M sodium acetate solution is added to 0.2 M acetic acid with stirring continuously, where pH is adjusted to 5.0 ± 0.05 .
- Starch : Soluble starch (Lintner) or equivalent is used.
- Substrate Solution : 10 g of starch (as dried form) is dispersed in 100 mL of cold water, where 300 mL of boiling water is slowly added. It is then boiled for 1 ~ 2 minutes with stirring. After cooling, it is then transferred into a 500 mL volumetric flask, which is then filled with water to make 500 mL.
- Glucose Standard Solution : 2.0 g of glucose (anhydrous) is accurately weighed and dissolved in water, to make total volume 1,000 mL.
- Methylene Blue Solution : 1 g of methylene blue is dissolved in water to make total volume 100 mL.

Lac Color

Definition Lac Color is extracted by water from the resinoid secreted by larvae of coccidium (Laccifer lacca KERR, Coccidae). The major component of this color is laccaic acid and anthraquinones. Dilutant, stabilizer, or solvent can be added for the purpose of color value adjustment and quality preservation.

Compositional Specifications of Lac Color

Content Color value ($E_{1cm}^{10\%}$) of Lac Color should not be less than the indicated value.

Description Lac Color is red ~ dark reddish brown liquid, lump, powder or paste with a slight characteristic scent.

Identification (1) Test Solution obtained in Color Value section for Lac Color is reddish violet. It has a maximum absorption near 490 nm.

(2) When adding 1 mL of hydrochloric acid to 10 mL of Test Solution in (1), it changes orange ~ orange red.

Purity (1) Arsenic : It should be no more than 4.0 ppm tested by Arsenic Limit Test.

(2) Lead : When 5.0 g of Lac Color is tested by Atomic Absorption Spectrophotometry or Inductively Coupled Plasma Emission Spectroscopy, its content should not be more than 8.0 ppm.

Assay (Color Value) Appropriate amount of Lac Color is accurately weighed so that the absorbance is within 0.3 ~ 0.7 and dissolved in 20 mL of sodium carbonate solution (1→200). Water is added so that the total volume is 100 mL. 1 mL of this solution is diluted to 100 mL with 0.1 N hydrochloric acid, Test Solution. If necessary, the solution is centrifuged and the supernatant is used. Using 0.1 N hydrochloric acid as a reference solution, absorbance A of the test solution is measured at the maximum absorption wavelength near 490 nm with 1 cm path length. Color value is obtained using the following equation.

$$\text{Color Value}(\mathit{E}_{1\text{cm}}^{10\%}) = \frac{A \times 1,000}{\text{weight of the sample(g)}}$$

Lactase

β-Galactosidase

Definition Lactase is an enzyme obtained from a culture of *Aspergillus niger* and its variety, *Aspergillus oryzae* and its variety, *Bacillus circulans*, *Saccharomyces* genus, and *Bacillus licheniformis* where the lactase gene of *Bifidobacterium bifidum* is inserted. Dilutant or stabilizer, and etc can be added for the purpose of activity adjustment and quality preservation and etc.

Compositional Specifications of Lactase

Description Lactase is white ~ deep brown power, particles, pastes or colorless ~ deep brown liquid.

Identification When Lactase is proceeded as directed under Activity Test, it should have the activity as Lactase.

Purity (1) Arsenic : It should be no more than 4.0 ppm tested by Arsenic Limit Test.

(2) Lead : When 5.0 g of Lactase is tested by Atomic Absorption Spectrophotometry or Inductively Coupled Plasma Emission Spectroscopy, its content should not be more than 5.0 ppm.

(3) Coliform Group : Lactase is tested by Microbe Test Methods for Coliform Group in General Test Methods in 「Standards and Specifications for Foods」. It should contain 30 colonies or less per 1 g of this product.

(4) Salmonella : Lactase is tested by Microbe Test Methods for Salmonella in General Test Methods in 「Standards and Specifications for Foods」. It should be negative (-).

(5) E. Coli : When Lactase is tested by Microbe Test Methods for E. Coli in General Test Method 「Standards and Specifications for Foods」, it should be negative (-).

Activity Test (activity)

Analysis Principle : Activity test is based on hydrolysis of o-Nitrophenyl-β-D-Galactopyranoside (ONPG) substrate for 15 minutes at 37°C and specified pH (4.5 for *Aspergillus niger* and its variety, *Aspergillus oryzae* and its variety, 6.0 for *Bacillus circulans*, 6.5 for *Saccharomyces* genus).

• **Preparation of Test Solution** : A Test Solution is prepared so that 1 mL contains 0.15~0.65 lactase unit. Sample is accurately weighed into a mortar, added an appropriate buffer solution, and ground, which is then transferred to a volumetric flask and filled with a buffer solution.

Test Procedure : 4 mL of substrate solution is placed in a 20×150 mm test tube with a stopper, which is then isothermalized in a water bath at 37 ± 0.1°C. 1 mL of Test Solution is mixed by shaking. After exactly 15 minutes, 1 mL of the mixed solution is added to a test tube with 1 mL of 10% sodium carbonate solution, which is then diluted to 10 mL with water. Separately, a reference solution is prepared by following the same procedure with 1 mL of water. Absorbance at 420 nm is measured with 1 cm of path length. Activity of enzyme is calculated by the following equation.

$$\text{LacU/g} = \frac{A \times 5 \times 10}{\text{---}}$$

$$\epsilon \times 15 \times W$$

- A : Average absorbance of Test Solution
5 : Amount of enzyme reaction mixture (mL)
10 : Final amount of diluted enzyme reaction mixture solution (mL)
 ϵ : Extinction coefficient measured with standard o-nitrophenol solution
15 : Time for isothermalization (minute)
W : Amount of sample contained in 1 mL of Test Solution (g)

Definition of Activity : 1 Lactase unit (LacU) is an amount of enzyme that extricates 1 μ mol of o-nitrophenol per 1 minute under the above conditions.

Test Solution

- Acetate Buffer Solution (for *Aspergillus niger* and its variety, *Aspergillus oryzae* and its variety) : 800 mL of water is added to 50 mL of 2 N acetic acid and pH is adjusted to 4.5 ± 0.05 with 2 N sodium hydroxide solution (pH 6.0 ± 0.05 for *Bacillus circulans*). Then the solution is diluted to 1,000 mL with water.
- P-E-M Buffer Solution (for *Saccharomyces* genus) : 27.2 g of monobasic potassium phosphate, 37.2 mg of EDTA (2 hydrate), and 20.3 mg of magnesium chloride ($MgCl \cdot 6H_2O$) are dissolved in 800 mL of water. pH is adjusted to 6.5 ± 0.05 with 2 N sodium hydroxide solution. Then the solution is diluted to 1,000 mL with water
- Standard o-Nitrophenol Solution : 139.0 mg of o-Nitrophenol is dissolved in 10 mL of 95% alcohol in a 1,000 mL volumetric flask, which is then filled with water to mark. 2, 4, 6, 8, 10, 12 and 14 mL each of this solution is placed in a 100 mL volumetric flask, which is then filled with 1% sodium carbonate solution. 1 mL of each diluted solution contains 0.02, 0.04, 0.06, 0.08, 0.10, 0.12, and 0.14 μ mol of o-nitrophenol, respectively. Using water as a reference solution, absorption at 420 nm with 1cm path length is measured and a calibration curve of absorption vs. μ mol/mL of o-nitrophenol is obtained. Calibration curve is a straight line through zero point. Extinction coefficient obtained that absorbance of each diluted solution divided o-nitrophenol μ mol/mL. Extinction coefficient (ϵ) should be approximately 4.65
- Substrate Solution for *Saccharomyces* : 250.0 mg of o-Nitrophenyl- β -D- galactopyranoside is dissolved in approximately 75 mL of PEM buffer solution in a 100 mL volumetric flask, which is then filled to 100 mL.

Storage Standard of Lactase

Lactase should be stored in a hermetic container in a cold dark place.

Lactic Acid

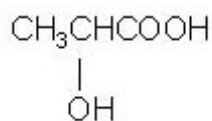

Chemical Formula: $\text{C}_3\text{H}_6\text{O}_3$

Molecular Weight: 90.08

INS No.: 270

Synonyms: 2-Hydroxypropanoic acid

CAS No.: 50-21-5

Definition Lactic Acid is a mixture of lactic acid and anhydrous lactic acid.

Compositional Specifications of Lactic Acid

Content Lactic Acid should contain not less than the 40.0% of lactic acid ($\text{C}_3\text{H}_6\text{O}_3 = 90.08$) and 95 ~ 105% of the indicate content.

Description Lactic Acid occurs as a white to light yellow solid or is a colorless to light yellow, clear syrupy liquid. It is odorless or has a slight or no unpleasant odor. It has an acid taste.

Identification (1) Lactic Acid solution (1→10) is acidic.

(2) Lactic Acid responds to the test for Lactate in identification.

Purity (1) Clarity and Color of Solution : Concentrate the Lactic Acid to 80% concentration. Take 10 g of the solution, add 12 mL of ether, and mix. The solution is clear, or passes the following test. Filter the solution mixed with ether through a glass filter (1G3), wash the residue three times with 10 mL of ether each time, then once with 10 mL of acetone, dry the residue together with the filter under reduced pressure at 50°C for 14 hours. The amount of the residue is not more than 0.07 g.

(2) Citric Acid, Oxalic Acid, Tartaric Acid, and Phosphoric Acid : When Lactic Acid (corresponding to 0.8 g of Lactic Acid) is dissolved in 10 mL of water, where 40 mL of potassium hydroxide solution is added and boiled for 2 minutes, it should not turn turbid

(3) Sulfate : When Lactic Acid (correspond in to 0.8 g of Lactic Acid) is tested by Sulfate Limit Test, its content should not be more than the amount that corresponds to 0.2 mL of 0.01 N sulfuric acid.

(4) Cyanide : Weigh Lactic Acid (corresponding to 0.8 g of Lactic Acid), and dissolve in water to make 100 mL. Take 10 mL of this solution. transfer into a Nestler tube, add 1 drop of phenolphthalein solution, and add sodium hydroxide solution (1→10) until the color of the solution changes to pink. Add 1.5 mL of sodium hydroxide solution (1→10) and water to make 20 mL, and heat in a water bath for 10 minutes. Cool, neutralize with diluted acetic acid (1→20), and after the pink color of the solution disappears, add 1 drop. Add 10 mL of phosphate buffer (pH 6.8) and 0.25 mL of chloroamine T, stopper tightly, shake gently, allow to stand for 3 ~ 5 minutes, add 15 mL of pyridine-pyrazolone solution and water to make 50 mL, and allow to stand at about 25°C for 30 minutes. The color of the solution does not change to blue.

- (5) Arsenic : It should be no more than 4.0 ppm tested by Arsenic Limit Test.
- (6) Lead : When 5.0 g of Lactic Acid is tested by Atomic Absorption Spectrophotometry or Inductively Coupled Plasma Emission Spectroscopy, its content should not be more than 2.0 ppm.
- (7) Mercury : When Lactic Acid is tested by Mercury Limit Test, its content should not be more than 1.0 ppm.
- (8) Iron : Lactic Acid (corresponding to 0.8 g of lactic acid) transfer into a Nestler Tube, and dissolve in 6 mL of dilute nitric acid (1→10) and 10 mL of water, add water to make 25 mL. Use this solution as the test Solution. 50 mg of ammonium persulfate and 5 mL of ammonium thiocyanate solution (2→25) are added to Test Solution. The resulting color should not be deeper than that of a solution prepared by treating 1 mL of iron standard solution by the same procedure as the Test Solution.
- (9) Chlorides : Accurately weigh a portion of sample equivalent to about 5 g of lactic acid, dissolve in 50mL of water, and neutralize to litmus with sodium hydroxide solution. (1 in 4). Add 2 mL of potassium chromate TS and titrate with 0.1N silver nitrate to the first appearance of a red tinge, its content should not be more than 0.2%.

1 mL of 0.1N silver nitrate solution = 3.545mg Cl

- (10) Readily Carbonizable Substances : Weigh Lactic Acid (corresponding to 2 g of lactic acid) adjust to 15°C, gradually superimpose on top of 5 mL sulfuric acid pre-adjusted to 15°C, and keep at 15°C. Even if a band is formed at the interface within 15 minutes, its color should not change to dark gray.
- (11) Volatile Fatty Acid : Lactic Acid (corresponding to 2 g of lactic acid), where water is added to bring the volume to 5 mL, if necessary, is heated in a water bath, it should not generate an odor of lactic acid.
- (12) Methanol : To Lactic Acid (corresponding to 4 g of lactic acid), add 8 mL of water and 5 g of calcium carbonate, distill the solution, take about 5 mL of the initial distillate, and add water to make 100 mL. Use this solution as the test solution. Measure 1.0 mL of the test solution, add 0.1 mL of phosphoric acid (1→20) and 0.2 mL of potassium permanganate solution (1→300), allow to stand for 10 minutes, add 0.4 mL of anhydrous sodium sulfite solution (1→5) and 3 mL of sulfuric acid, then add 0.2 mL of chromotropic acid solution. The color of the solution is not darker than that of the following reference solution. Measure 1.0 mL of methanol. add water to make 100 mL, measure 1.0 mL of this solution, and add water to make 100 mL. Use this solution as the solution.

Residue on Ignition When thermogravimetric analysis is done with Lactic Acid, the residues should not be more than 0.1%.

Assay Accurately weigh 3 g of Lactic Acid, add 40 mL of 1 N sodium hydroxide solution, heat in a water bath for 10 minutes, and titrate the excess alkali with 1 N sulfuric acid while hot (indicator : 1 ~ 2 drops of phenolphthalein solution). Perform a blank test in the same manner.

1 mL of 1 N sodium hydroxide = 90.08 mg of $C_3H_6O_3$

Lactitol

Lactit

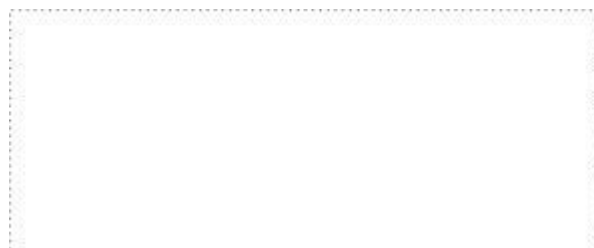

Chemical Formula: $C_{12}H_{24}O_{11}$

Molecular Weight: 344.32

Synonyms: Lactit; Lactobiosit

INS No.: 966

CAS No.: 585-86-4

Compositional Specifications of Lactitol

Content Lactitol, when calculated on the dried basis(anhydrous), should contain within a range of 95.0~102.0% of lactitol ($C_{12}H_{24}O_{11}$).

Description Lactitol occurs as crystalline powder or colorless liquid. It is odorless and has a sweet taste.

Identification (1) Lactitol is readily soluble in water.

(2) When Lactitol is quantitatively analyzed, it shows the peaks at the identical positions as the lactitol standards.

Purity (1) Specific Rotation : Approximately 10 g of Lactitol is precisely weighed and dissolved in water so that the total volume becomes 100 mL. When Optical rotation of this solution is measured and converted to a dehydrated form, it should be within a range of $[\alpha]_D^{25} = +13\sim+15^\circ$.

(2) Chloride : When 10 g (amount that is converted to dehydrated form) of Lactitol is tested by Chloride Limit Test, the content should not be more than the amount that corresponds to 3.0 mL of 0.01 N hydrochloric acid.

(3) Sulfate : When 10 g (amount that is converted to dehydrated form) of Lactitol is tested by Sulfate Limit Test, the content should not be more than the amount that corresponds to 4.0 mL of 0.01 N sulfuric acid.

(4) Arsenic : It should be no more than 2.6 ppm tested by Arsenic Limit Test.

(5) Lead : When 5.0 g of Lactitol is tested by Atomic Absorption Spectrophotometry or Inductively Coupled Plasma Emission Spectroscopy, its content should not be more than 1.0 ppm.

(6) Nickel : When 10 g (amount that is converted to dehydrated form) of Lactitol is tested according to Purity (6) for 「D-Maltitol」, the content should not be more than 2 ppm.

(7) Reduced Sugars : 15 g of Lactitol (amount that is converted to dehydrated form) is dissolved in 25

mL of water in an Erlenmeyer flask. Then 25 mL of copper solution is added. The solution is heated so that it boils within 2 minutes. It is then boiled for exactly 10 minutes and cooled immediately in running water. After 5 minutes, 3 g of potassium iodide is added and the solution is acidified by 20 mL of 25% hydrochloric acid. The flask is shaken until bubbling stops. Remaining bubbles are removed by adding 2 ~ 3 drops of ether. 1 mL of starch solution is added to the above solution, which is then titrated with 0.1 N sodium thiosulfate solution. The consumed amount (mL) of 0.1 N sodium thiosulfate solution is S. Separately, a blank test is carried out with 25 mL of copper solution and 25 mL of water following the same procedure. The consumed amount (mL) of 0.1 N sodium thiosulfate solution is B. Using the difference in consumption (B-S), a reduction equivalent as lactic acid can be obtained from the following table. It should not be more than 0.2%.

0.1 N sodium thiosulfate solution (mL)	Lactic Acid (mg)
1	3.6
2	7.3
3	11.0
4	14.7
5	18.4
6	22.1
7	25.8
8	29.5
9	33.2
10	37.0
11	40.8
12	44.6
13	48.4
14	52.2
15	56.0
16	59.9
17	63.8
18	67.7
19	71.7
20	75.7
21	79.8
22	83.9

• Copper Solution : 338 g of sodium carbonate (10 hydrated) is dissolved in 300 ~ 400 mL of warm water. Then a solution of 50 g of citric acid in 500 mL water is added. Again a solution of 25 g of iron free cupric sulfate (5 hydrate) in 100 mL water is added. Water is added to bring the total volume to 1l. This solution is set-aside for 2 ~ 3 days and the clear supernatant is collected for use by tilting the container. The solution is sealed and stored.

(8) Other polyvalence alcohols : 40 g of Lactitol is precisely weighed and quantitatively analyzed. The content of polyvalence alcohols (as converted to dehydrated form) should not be more than 2.5%. The content of by-products in sample such as galactitol, mannitol, sorbitol, ribitol, erythritol, and other poly alcohols is obtained as follows. The areas of peaks from lactitol to sorbitol are added up and the content is calculated as lactitol.

$$\text{Content of other polyvalence alcohols(\%)} = \frac{W_s \times R_u}{W_u \times R_s} \times 100$$

W_s : Amount of lactitol standard (g)

W_u : Amount of sample(g)

R_u : Sum of peak areas of polyvalence alcohols in Test Solution

R_s : Peak area of lactitol in Standard Solution

Water Content Water content of Lactitol is determined by water determination (Karl-Fisher Method) and should not be more than 10.5% for crystalline powder, not more than 31 % for liquid form.

Residue on Ignition When thermogravimetric analysis is done with precisely weighed 2 g of Lactitol (amount that is converted dehydrated form), the amount of residue should not be more than 0.1%.

Assay 40 g of Lactitol, precisely weighed, is dissolved in water to make 100 mL (Test Solution). Separately, 40 g of lactitol standard, 400 mg each of sorbitol standard, and mannitol standard are precisely weighed and dissolved in water. The total volume is brought up to 100 mL with water (Standard Solution). 10 μ l of each Test Solution and Standard Solution is injected into liquid chromatography using the following operation conditions. The content (%) of lactitol is calculated by the following equation. The order of peak detection on the chromatogram is lactitol, ribitol, erythritol, mannitol, galactitol, and sorbitol.

$$\text{Content of lactitol(\%)} = \frac{\text{weight of the standard(g)}}{\text{weight of the}} \times \frac{\text{lactitol peak area of test solution}}{\text{lactitol peak area of standard}} \times 100$$

sample(g)

solution

Operation Conditions

- Detector : Differential refractometer (RI Detector)
- Column : Aminex HPX 87C (calcium form) or its equivalent
- Column Temperature : 85°C
- Mobile Phase : Water
- Flow Rate : 0.6 mL/min

Lactoferrin Concentrates

Definition This is obtained by concentrating milk that is previously defatted and purified by separation.

The major component is lactoferrin.

Compositional Specifications of Lactoferrin Concentrates

Content Lactoferrin Concentrates should contain not less than 90.0% of lactoferrin.

Description Lactoferrin Concentrates is pale orange red ~ pale reddish brown powder and scentless.

Identification When Lactoferrin Concentrates is quantitatively analyzed, a lactoferrin peak is observed at 280 nm.

Purity (1) Arsenic : It should be no more than 2.0 ppm tested by Arsenic Limit Test.

(2) Lead : When 5.0 g of Lactoferrin Concentrates is tested by Atomic Absorption Spectrophotometry or Inductively Coupled Plasma Emission Spectroscopy, its content should not be more than 2.0 ppm.

(3) pH : pH of Lactoferrin Concentrates solution (2→100) should be 5.2~7.2.

(4) Coliform Group : Lactoferrin Concentrates is tested by Microbe Test Methods for Coliform Group in General Test Methods in 「Standards and Specifications for Foods」. It should contain 30 or less per 1 g of this product.

Residue on Ignition When Residue on Ignition analysis is done with 1 g of Lactoferrin Concentrates, the amount of residue should not be more than 1.3%.

Assay Approximately 20 mg of Lactoferrin Concentrates is accurately weighed and dissolved in 0.5 M of sodium chloride solution and to make volume 10 mL. The solution is filtered through a 0.45 μm Millipore filter, Test Solution. Separately, a Standard Solution is prepared with 20 mg of lactoferrin standard following the same procedure. 20 μl each of Standard Solution and Test Solution is injected into liquid chromatograph and the content of lactoferrin is obtained from the following equation.

$$\text{Content(\%)} = \frac{A_u \times W_s}{A_s \times W_u} \times 100$$

A_u : Peak area of test solution

A_s : Peak area of standard solution

W_s : Amount of standard material (mg)

W_u : Amount of sample (mg)

Operation Conditions

-Detector : UV 280 nm

- Column : Ashaipak C4P 50(4.6 mm × 150 mm) or equivalent
- Column Temperature : Room temperature
- Mobile Phase : Solution A : Solution B (30 : 70)
 - Solution A : acetonitrile : 0.5M sodium chloride solution (1 : 9)
 - Solution B : acetonitrile : 0.5M sodium chloride solution (5 : 5)
 - Solutions A, B contains 0.03% of Trifluoroacetic acid.
- Flow rate : 0.8 mL/min

Lauric Acid

Decanoic acid

Chemical Formula: $C_{12}H_{24}O_2$

Molecular Weight: 200.32

INS No.: 570

Synonyms: Dodecanoic acid

CAS No.: 143-07-7

Definition Lauric Acid is a solid fatty acid obtained from coconut oil and other vegetable oils. Its major component is lauric acid ($C_{12}H_{24}O_2$).

Compositional Specifications of Lauric Acid

Description Lauric Acid is white ~ pale yellow crystalline solid or powder.

Purity (1) Acid Value : When 0.5 g of Lauric Acid is precisely weighted, and proceeded as directed under Acid value in Fats Test, the Acid value should be 252~287.

(2) Solidification point : Solidification point of Lauric Acid should be 26.0~44.0.

(3) Lead :When 5.0 g of Lauric Acid is tested by Atomic Absorption Spectrophotometry or Inductively Coupled Plasma Emission Spectroscopy, its content should not be more than 1.0 ppm.

(4) Arsenic : It should be no more than 4.0 ppm tested by Arsenic Limit Test.

(5) Mercury : When Lauric Acid is tested by Mercury Limit Test, its content should not be more than 1.0ppm.

(6) Iodine Value : Approximately 8.3 g of Lauric Acid is precisely weighted into a 500 mL Erlenmeyer flask with a stopper which contains 20 mL of 1 : 1 mixture of glacial acetic acid : cyclohexane and 25 mL of Weiss solution. A stopper is placed on the flask which is vigorously shaken and set aside for 1 hour in a dark place. 20 mL of potassium iodide solution and 100 mL of water(previously boiled and cooled) are added to the flask. The excess iodine is titrated with 0.1 N sodium thiosulfate solution. 0.1 N sodium thiosulfate solution is added drop wise until yellow color disappears. Starch solution is added and the titration is continued until the blue color disappears completely. Near the end point, the flask is vigorously shaken with a stopper. Separately, a blank test is carried out by the same procedure. Iodine value is obtained by the following equation and it should not be more than 3.0.

$$\text{Iodine Value} = \frac{(B-S) \times 1.269}{\text{weight of the sample(g)}}$$

B : Consumed amount of 0.1 N sodium thiosulfate solution in the blank test (mL)

S : Consumed amount of 0.1 N sodium thiosulfate solution in the test for sample (mL)

- (7) Saponification Value : 3 g of Lauric Acid is precisely weighted into a 250 mL flask, where 50 mL of 0.5 N alcoholic solution of potassium hydroxide is added. This solution is used as test solution. When test solution is proceeded as directed under Acid value in Fats Test, the Acid value should be 253~287.
- (8) Unsaponifiable matter : 5 g of Lauric Acid is precisely weighted into a 250 mL flask, where 2g of potassium hydroxide and 40 mL of alcohol are added and gently refluxed for 1 hour with a reflux condenser. The solution transfer into a separatory funnel (3.5 cm diameter x 30 cm length with 40 mL, 80 mL, and 130 mL scale marks) with a stopcock. The flask is washed with sufficient amount of alcohol, which is added to the funnel (total volume = 40 mL). The flask is washed with warm and cold water, which is added to the funnel (total volume = 80 mL). Finally, the flask is washed with a few mL of petroleum ether, which is added to the funnel. Cool the solution, 50 mL of petroleum ether is added to the funnel. The funnel is shaken vigorously for 1 minute and then settled to separate two phases completely. The supernatant ether layer is collected in a 500 mL separatory funnel with a stopcock. The aqueous layer is again extracted 6 times with 50 mL each of ether. These extracts are added to the first extract. The combined extracts are washed with 25 mL of 10% alcohol. This procedure is repeated until the aqueous layer doesn't get colorized by phenolphthalein TS. When this is accomplished, aqueous phase is discarded and the ether extract transfer into a pre-weighted beaker. With 10 mL of ether, the funnel is washed, which is added to the beaker. Ether layer is evaporated to dryness in a water bath, which is then dried at 100°C for 30 minutes until the weight becomes constant. Then the residue is cooled in a desiccator and weighted. The residue dissolve in 50 mL of warm alcohol (neutralized with sodium hydroxide using phenolphthalein as an indicator). The resulting solution is titrated with 0.02 N sodium hydroxide solution until a pale red color persists. The amount of oleic acid is obtained by multiplying the consumed amount of sodium hydroxide solution with 5.659(mg). The exact amount of unsaponifiables is obtained by subtracting the amount of fatty acid (as oleic acid) from the amount of residues. The content of unsaponifiable matter is calculated by the following equation and it should not be more than 0.3%.

$$\text{Unsaponifiable matter(\%)} = \frac{\text{content of residue(mg)} - \text{content as oleic acid(mg)}}{\text{weight of the sample(g)}} \times \frac{100}{1,000}$$

Water Content Water content of Lauric Acid is determined by water determination (Karl-Fisher Titration) and should not be more than 0.2%

Residue on Ignition When Residue on Ignition analysis is done with accurately weighted 10 g of Lauric Acid, the amount of residue should not be more than 0.1%.

Laver Color

Definition Laver Color is a pigment obtained by extracting fronds of laver (*Porphyra tenera* KJELLM.) of bangiaceae (a red algae) with water or faintly acidic aqueous solution at room temperature. Its major pigment component is phycoerythrin. Diluent or stabilizer can be added for the purpose of activity adjustment and quality preservation.

Compositional Specifications of Laver Color

Content Color value ($E_{1cm}^{10\%}$) of Laver Color should be more than the indicated value.

Description Laver Color is orange ~ red paste or liquid with a characteristic scent.

Identification (1) A solution of Laver Color in citric acid buffer solution with pH 6.0 (1→100) is pink ~ red in color.

(2) When 4.0 g of ammonium sulfate is dissolved in 10 mL of the solution in (1) and set aside, red precipitates are formed.

(3) A solution of Laver Color in citric acid buffer solution with pH 6.0 has maximum absorption bands near 565 nm, 540 nm, and 490 nm.

Purity (1) Arsenic : It should be no more than 4.0 ppm tested by Arsenic Limit Test.

(2) Lead : When 5.0 g of Laver Color is tested by Atomic Absorption Spectrophotometry or Inductively Coupled Plasma Emission Spectroscopy, its content should not be more than 10.0 ppm.

Assay(color value) Appropriate amount of Laver Color is precisely weighted so that the absorption is within 0.3 ~ 0.7 and dissolved in citric acid buffer solution (pH 6.0) so that the total volume is 100 mL (Test Solution). If necessary, the solution is centrifuged and the supernatant is used. Using citric acid buffer solution (pH 6.0) as a reference solution, absorption A is measured at the maximum absorption near 565 nm with 1 cm path length. Color value is obtained using the following equation.

$$\text{Color Value}(E_{1cm}^{10\%}) = \frac{A \times 10}{\text{weight of the sample(g)}}$$

• Citric acid-dibasic sodium phosphate buffer solution (pH 6.0)

Solution 1 : 0.1 M citric acid solution : 1L of solution containing 21.01 g of citric acid ($C_6H_8O_7 \cdot H_2O$).

Solution 2 : 0.2 M dibasic sodium phosphate solution : 1L of solution containing 71.63 g of dibasic sodium phosphate ($Na_2HPO_4 \cdot 12H_2O$).

Solution 1 and Solution 2 are mixed well (73.7:126.3) and its pH is adjusted to 6.0.

Lecithin

INS No.: 322(i)

Synonyms: Phosphatides; Phospholipids

CAS No.: 8002-43-5

Definition Lecithin is prepared from oil seeds or yolk of egg. Its major component is phospholipid.

Compositional Specifications of Lecithin

Description Lecithin is transparent or semi transparent pale yellow ~ dark brown viscous liquid, semi-solid, lump, powder or granule with slight characteristic scent and taste.

Identification (1) 1 g of Lecithin is dissolved in 5 mL of petroleum ether. Upon adding 15 mL of acetone, white ~ pale yellow precipitates are formed.

(2) 1 g of Lecithin is placed in a flask for decomposition, where 5 g of powdered potassium sulfate, 0.5 g of copper sulfate, and 20 mL of sulfuric acid are added. The flask is sloped to 45°C angle and gently heated so that it doesn't bubble. Then the temperature is raised to boil until the solution becomes transparent blue. It is then heated for 1 ~ 2 hours and cooled and the same amount of water is added. 10 mL of ammonium molybdate (1→5) is added to 5 mL of the resultant solution. Upon heating yellow precipitates are formed.

(3) 5 mL of diluted hydrochloric acid (1→2) is added to 0.5 g of Lecithin, which is then heated for 2 hours in a water bath and filtered, Test Solution. 0.01 mL of Test Solution is tested by Method 1 in Paper Chromatography using a mixed solution of n butyl alcohol, acetic acid, and water (4 : 1 : 2) as a developing solution. An orange red spot corresponds to the spot obtained from the control solution is observed. For the filter paper, No.2 filter paper for chromatography is used. Development is stopped when the developing solvent rises about 25 cm, which is then dried in air. Colour is developed by spraying Dragendorf TS and observed in daylight. 0.01 mL of the reference solution is prepared by dissolving 0.1 g of choline chloride in water (total volume 20 mL).

Purity (1) Acid Value : About 2 g of Lecithin is accurately weighed and dissolved in 50 mL of petroleum ether. Then add 50 mL of alcohol, Test Solution. When it tested as Acid Value in Oil and Fat Test, the value should not be more than 36.

(2) Toluene Insoluble matter : About 10 g of Lecithin is accurately weighed and dissolved in 100 mL toluene by shaking in a 250 mL Erlenmeyer flask. Insoluble matter are filtered through a crucible type G3 glass filter (pore size 16 ~ 40 μm), previously weighed, and washed with 25 mL of toluene several times. It is then dried for 1 hour at 105°C and cooled in a desiccator and weighed. The content should not be more than 0.3%.

(3) Acetone Soluble Substances : Approximately 2 g of Lecithin is accurately weighed into a 50 mL graduated centrifuge tube with a stopper, where 3 mL of petroleum ether and 15 mL of acetone. It is then well mixed by stirring and placed in an ice bath for 15 minutes. 50 mL of acetone, previously chilled to 0~5°C, is added to the solution, which is well mixed by stirring and placed in an ice bath

for 15 minutes. It is then centrifuged for 10 minutes to 3,000rpm by the following procedure. The supernatant is taken into a previously weighed flask. Again, 0 ~ 5°C acetone is added to make 50mL, and cooled in an ice bath while stirring and mixing. It is then centrifuged under the following manner. The supernatant is transferred into a flask and distilled. The residue is dried for 1 hour at 105°C. The amount of the residue should not be more than 40%.

- (4) Peroxide Value : 5 g of Lecithin is accurately weighed into a 250 mL of Erlenmeyer flask with a stopper. It is then dissolved to a clear solution in 35 mL of a 3 : 2 mixture of glacial acetic acid and chloroform. Clean nitrogen is passed through to replace air in the flask. 1 mL of potassium iodide TS is added while nitrogen is bubbled through. A stopper is placed immediately and the flask is shaken for 1 minute. It is then allow to stand for 5 minutes in a dark place. 75 mL of water is added and shaken vigorously with a stopper. It is then titrated with 0.01 N sodium thiosulfate solution (indicator : starch TS). Peroxide value is obtained from the following equation. It should not be more than 10. Separately, a blank test is carried out for correction.

$$\text{Peroxide Value} = \frac{\text{consumed amount of 0.01N sodium thiosulfate solution (mL)}}{\text{weight of sample (g)}} \times 10$$

- (5) Arsenic : It should be no more than 4.0 ppm tested by Arsenic Limit Test.

- (6) Lead : When 5.0 g of Lecithin is tested by Atomic Absorption Spectrophotometry or Inductively Coupled Plasma Emission Spectroscopy, its content should not be more than 2.0 ppm.

- (7) Mercury : When 0.1 g of Lecithin is accurately weighed and tested by Mercury Test Method, its content should not be more than 1.0ppm.

Loss on Drying When Lecithin is dried for 1 hours at 105°C, the weight loss should not be more than 2.0%.

L-Leucine

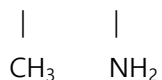
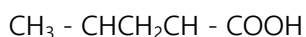

Chemical Formula: $\text{C}_6\text{H}_{13}\text{NO}_2$

Molecular Weight: 131.17

INS No.: 641

Synonyms: L-2-Amino-4methylvaleric acid

CAS No.: 61-90-5

Compositional Specifications of L-Leucine

Content L-Leucine should contain within a range of 98.5 ~ 101.5% L-leusine ($\text{C}_6\text{H}_{13}\text{NO}_2$) after dried.

Description L-Leucine occurs as white crystals or crystalline powder. It is odorless or has a characteristic odor and has a slightly bitter taste.

Identification L-Leucine sublimes at 150°C.

Purity (1) Specific Rotation : 4 g of L-Leucine is precisely weighed and dissolved in 6 N hydrochloric acid. The total volume is brought up to 100 mL. Optical rotation of this solution is measured. When it is converted into a dehydrated form, it should be within a range of $[\alpha]_D^{20} = +14.5 \sim +16.5^\circ$

(2) Lead : When 5.0 g of L-Leucine is tested by Atomic Absorption Spectrophotometry or Inductively Coupled Plasma Emission Spectroscopy, its content should not be more than 5.0 ppm.

(3) Arsenic : It should be no more than 4.0 ppm tested by Arsenic Limit Test.

Loss on Drying When L-Leucine is dried for 3 hours at 105°C, the weight loss should not be more than 0.2%.

Residue on Ignition Residue on ignition of L-Leusine should not be more than 0.1%.

Assay Dissolve 0.4 g of L-Leusine, precisely dried and accurately weighed, in 3 mL of formic acid and 50 mL of glacial acetic acid. This solution is titrated with 0.1 N perchloric acid solution (indicator : 2 drops of crystal violet buffered in glacial acetic acid). At the end point, the solution turns bluish green. Separately, a blank experiment is done following the same procedure.

1 mL of 0.1 N perchloric acid solution = 13.12 mg $\text{C}_6\text{H}_{13}\text{NO}_2$

Licorice Extract

Definition Licorice Extract is an extract from the roots and root stocks of licorice of leguminosae (*Glycyrrhiza inflata* BATALIN, *Glycyrrhiza uralensis* FISCHER, *Glycyrrhiza glabra* LINNE) or the same genus, which is extracted with hot water or is extracted and purified with alkalic solution in room or slightly tepid temperature. Its major component is glycyrrhizinic acid. Licorice Extract includes purified licorice, and crude licorice.

Compositional Specifications of Licorice Extract

Content Purified Licorice should contain more than 50.0% and crude licorice less than 50.0% as glycyrrhizinic acid, respectively.

Description Purified licorice is white ~yellow crystal or powder and crude licorice is yellow ~ brown powder, thin platelet, granule, lump, liquid, or paste.

Identification 5~10 mg of Licorice Extract is dissolved in 10 mL of 50% alcohol, Test Solution. Separately, 5 mg of glycyrrhizinic acid standard is dissolved in 10 mL of 50% alcohol, Standard Solution. Each of the solution is proceeded as directed under thin layer chromatography. 2 μ l of each solution drop-wise is added on to a thin layer plate, which is prepared by using silica gel (with phosphor) for thin layer chromatography. Using a mixture of n-butyl alcohol : water : acetic acid (7:2:1) as a developing solvent, each plate is developed up to 10 cm, and then dried in air. When these plates are observed under UV light (major wavelength at 254 nm), one of the spots for test solution should have the same color tone and Rf against the dark violet spot for standard solution (glycyrrhizinic acid).

Purity (1) Arsenic : It should be no more than 4.0 ppm tested by Arsenic Limit Test.

(2) Lead : When 5.0 g of Licorice Extract is tested by Atomic Absorption Spectrophotometry or Inductively Coupled Plasma Emission Spectroscopy, its content should not be more than 2.0 ppm.

Residue on Ignition 1 g of Licorice Extract is dried in a water bath, if necessary. When Residue on Ignition analysis is done, the amount of residue should not be more than 15.0%.

Assay Licorice Extract which corresponds to approximately 20 mg as glycyrrhizinic acid is accurately weighed, dissolved in 50% alcohol, and the total volume is make to 100 mL, Test Solution. Separately, 20 mg of glycyrrhizinic acid standard is accurately weighed, dissolved in 50% alcohol, and the total volume is make to 100 mL, Standard Solution. 20 μ l of each solution is injected into liquid chromatography as the following operation conditions. The content of licorice extract is obtained from the following equation.

$$\text{Content(\%)} = \frac{\text{TG} \times W_s}{\text{SG} \times W} \times 100$$

SG : Peak area of standard solution

TG : Peak area of test solution

Ws : Weight of standard (mg) (converted into a anhydrous form)

W : Weight of sample (mg) (converted into an anhydrous form)

Operation Conditions

-Detector : UV 254 nm

-Column : μ -Bondapak C18 (inner diameter 4~6 mm, length 15~30 cm) or its equivalent

-Column Temperature : 40°C

-Mobile Phase : 2% acetic acid : acetonitrile (20 : 11)

-Flow Rate : It is adjusted so that the retention time of glycyrrhizinic acid is approximately 10 minutes.

Linalool



Chemical Formula: $C_{10}H_{18}O$

Molecular Weight: 154.25

Synonyms: Linalol; Licareol

CAS No.: 78-70-6

Compositional Specifications of Linalool

Content Linalool should contain not less than 92.0% of linalool ($C_{10}H_{18}O$).

Description Linalool is a colorless, transparent liquid having a characteristic odor.

Identification To 1 mL of Linalool, add 1 mL of anhydrous acetic acid and 1 drop of phosphoric acid, keep at a slight warm temperature for 10 minutes, add 1 mL of water, shake in warm water for 5 minutes, cool, and add sodium carbonate solution to weakly alkalize the solution. An odor of sodium acetate is evolved.

Purity (1) Specific Gravity : Specific gravity of Linalool should be within a range of 0.858 ~ 0.867.

(2) Refractive Index : Refractive Index n_D^{20} of Linalool should be within a range of 1.461 ~ 1.465

(3) Clarity and Color of Solution : When 1 mL of Linalool is dissolved in 4 mL of 60% ethanol, the solution should be clear.

(4) Chlorides : When Linalool is tested by Copper Mesh Test Method in Halogenated Compounds for Flavoring substance test, it should be appropriate.

(5) Acid Value : Acid value of Linalool is tested by Acid Value in Flavoring Substance Test. It should not be more than 1.

(6) Ester Value : When about 5 g of Linalool, precisely weighed, is tested by Ester Value in Flavoring Substance Test. It should not be more than 2.

Assay Transfer 10 mL of Linalool into a flask, allow to stand in ice for 10 minutes, add 20 mL of dimethylaniline, and shake well. Add 10 mL of acetyl chloride (for linalool Assay) and 5 mL of anhydrous acetic acid. With a air condenser, shake well, allow to stand in cold water for 5 minutes, and allow to stand for 30 minutes at room temperature. Heat in a water bath at 50°C for 4 hours, cool, transfer the contents to a separatory funnel, and wash 3 times with 75 mL of ice water each time. Wash the oily layer with 25 mL of dilute sulfuric acid. Add sodium hydroxide solution to alkalize the washings until it does not become turbid. Wash with 10 mL of sodium carbonate solution until washing become

alkaline. Wash with 25 mL of sodium chloride solution until the washings become neutral. Oily phase is transferred into a dried flask. Add 2 g of anhydrous sodium sulfate, shake and allow to stay for 30 minutes, and filter. Take 1 g of filtrate, precisely weighed, test by Ester Value in Flavoring Substances Test. Separately, a blank test is carried out by the same method.

$$\text{Content(\%)} = \frac{(a - b) \times 77.12}{[s - (a - b) \times 0.02102] \times 1,000} \times 100$$

a : Consumed amount of 0.5 N hydrochloric acid in blank test (mL)

b : Consumed amount of 0.5 N hydrochloric acid of the Test Solution (mL)

s : Amount of filtrate used (g)

Linalyl Acetate



Chemical Formula: $C_{12}H_{20}O_2$

Molecular Weight: 196.29

Synonyms: Bergamol; Licareol acetate

CAS No.: 115-95-7

Compositional Specifications of Linalyl Acetate

Content Linalyl Acetate should contain not less than 90.0% of linalyl acetate ($C_{12}H_{20}O_2$).

Description Linalyl Acetate is a colorless to light yellow, transparent liquid having a characteristic odor.

Identification To 1 mL of Linalyl Acetate, add 5 mL of 10% alcoholic solution of potassium hydroxide solution, and heat in a water bath. The characteristic odor disappears, and an odor of linalool is evolved. Cool, and add 12 mL of water and 2 mL of diluted hydrochloric acid (1→3). The solution responds to the test for Acetate (3) in Identification.

Purity (1) Specific Gravity : Specific gravity of Linalyl Acetate should be within a range of 0.895 ~ 0.914
(2) Refractive Index : Refractive Index n_D^{20} of Linalyl Acetate should be within a range of 1.449 ~ 1.457
(3) Clarity and Color of Solution : When 1 mL of Linalyl Acetate is dissolved in 5 mL of 70% alcohol, the solution should be clear.
(4) Acid Value : Acid value of Linalyl Acetate is tested by Acid Value in Flavoring Substance Test. The content should not be more than 1.

Assay Accurately weigh about 1 g of Linalyl Acetate, and proceed as directed under Ester Value and Ester Content in Flavoring Substances Tests.

1 mL of 0.5 N alcoholic solution of potassium hydroxide = 98.14 mg of $C_{12}H_{20}O_2$

Lipase

Definition Lipase is an enzyme obtained from a culture of *Aspergillus niger* and its variety, *Aspergillus oryzae* and its variety, *Candida rugosa*, *Rhizopus oryzae*, and *Aspergillus oryzae* where the lipase gene of *Rhizomucor miehei*, *Aspergillus niger* where the lipase gene of *Thermomyces lanuginosus*, *Aspergillus oryzae* where the lipase gene of *Fusarium oxysporum*, *Aspergillus oryzae* where the lipase gene of *Thermomyces lanuginosus*, *Aspergillus niger* where the lipase gene of *Candida antarctica* is inserted, and animal pancreas tissue or forestomach of animal. Dilutant or stabilizer can be added for the purpose of activity adjustment and quality preservation.

Compositional Specifications of Lipase

Description Lipase is white ~ dark brown power, granule, paste or colorless ~ dark brown liquid.

Identification When Lipase is proceeded as directed under Activity Test, it should have the activity as Lipase.

Purity (1) Arsenic : It should be no more than 4.0 ppm tested by Arsenic Limit Test.

(2) Lead : When 5.0 g of Lipase is tested by Atomic Absorption Spectrophotometry or Inductively Coupled Plasma Emission Spectroscopy, its content should not be more than 5.0 ppm.

(3) Coliform Group : Lipase is tested by Microbe Test Methods for Coliform Group in General Test Methods 「Standards and Specifications for Foods」. It should contain 30 or less per 1 g of this product.

(4) Salmonella : Lipase is tested by Microbe Test Methods for Salmonella in General Test Methods 「Standards and Specifications for Foods」. It should be negative (-).

(5) E. Coli : When Lipase is tested by Microbe Test Methods for E. Coli in General Test Method 「Standards and Specifications for Foods」, it should be negative (-).

Activity Test (activity)

•Analysis Principle : Activity test is based on measuring the ratio of increasing hydrolysis rate of Tributyrin by potentiometric titration.

•Preparation of Test Solution : Sample is diluted with glycine so that 1 mL of the solution contains 2,000~5,000 Lipase units. The resultant solution is further diluted with water so that 1 mL of the resulting Test Solution contains 0.5~1.5 Lipase units.

Test Procedure : The burette of the titrator is filled with 0.05 N sodium hydroxide solution and the scale mark is adjusted. Temperature and pH are set to 30°C and 7.0, respectively. 15.0 mL of substrate emulsifying solution is transferred into a reaction vessel of the titrator and a magnetic stir bar is placed. The reaction vessel is attached to the titrator and 1.0 mL of Test Solution is added. Then the titrator is switched on. The reaction is maintained while adjusting the pH at 7.0 with 0.05 N sodium hydroxide solution. A calibration curve is prepared vs. the consumed amount of 0.05 N sodium hydroxide solution per minute.

(Note : Reaction rate shown in the recorder for 5 minutes should be a straight line.)

Activity of the enzyme is obtained by the following equation.

$$\text{LU/g} = \frac{R \times N \times 1,000}{W}$$

R : Consumed amount of titrant per minute in the straight line region (mL/min)

N : Normality of sodium hydroxide solution

1,000 : Conversion factor from mol to μmol

W : Weight of sample in 1 mL of Test Solution (g)

Definition of Activity : 1 Lipase unit (LU) corresponds to the amount of enzyme which separates 1 μmol of butyric acid per minute from the substrate under the conditions above.

Solutions

- Emulsifying Solution : 17.9 g of sodium chloride and 0.41 g of mono potassium phosphate are added in 400 mL of water, where 540 mL of glycerol is added. 6.0 g of gum Arabic (Sigma, or its equivalent) is added to the above solution, which is then shaken vigorously until it dissolves. Water is added to bring the total volume to 1,000 mL.
- Glycine Buffer Solution (0.1 M) : 7.5 g of glycine and 3.8 g of sodium hydroxide are dissolved in 900 mL of water. After adjusting the pH to 10.8, water is added to bring the total volume to 1,000 mL.
- Substrate Emulsifying Solution : 15.9 mL of Tributyrin (Sigma, or equivalent) placed in a homogenizer, where 50 mL of emulsifier and 235 mL of water are added. It is then homogenized for 15 minutes at a high speed. Solutions are isothermalized at 30°C for at least 15 minutes in a water bath prior to use. This solution should be used within 4 hours.

Storage Standard of Lipase

Lipase should be stored in a hermetic container in a cold dark place.

Liquid Paraffin

INS No.: 905a

Synonyms: Food grade mineral oil; White mineral oil

CAS No.: 8012-95-1

Definition Liquid Paraffin is a mixture of hydrocarbons derived from petroleum.

Compositional Specifications of Liquid Paraffin

Description Liquid Paraffin is colorless, clear, and viscous liquid having almost no fluorescence. It is odorless and tasteless.

Identification (1) Liquid Paraffin is placed in a porcelain dish. When ignited, it burns with a bright flame, which generates a characteristic odor of paraffin vapor.

(2) Approximately 0.5 g of Liquid Paraffin is mixed with the same amount of sulfur. When the mixture is heated, an odor of hydrogen sulfide is generated.

Purity (1) Free acid and free alkali : Approximately 10 mL of hot water and 1 drop of phenolphthalein are added to 10 mL of Liquid Paraffin. When the mixture is vigorously shaken, it should not develop red. When 0.2 mL of 0.02N sodium hydroxide solution is added and mixed by shaking, it should develop red.

(2) Arsenic : It should be no more than 4.0 ppm tested by Arsenic Limit Test.

(3) Lead : When 5.0 g of Liquid Paraffin is tested by Atomic Absorption Spectrophotometry or Inductively Coupled Plasma Emission Spectroscopy, its content should not be more than 1.0 ppm.

(4) Polynuclear aromatic hydrocarbons : 25 mL of Liquid Paraffin is precisely taken in a 25 mL measuring cylinder and transferred into a 100 mL separatory funnel, where 25 mL of n-hexane is added and well mixed by shaking. 5 mL of dimethyl sulfoxide is added to the solution, which is mixed by shaking vigorously for 2 minutes and settled for 15 minutes. The lower layer is transferred into a 50 mL separating funnel, where 2 mL of n-hexane is added, shaken vigorously for 2 minutes, and settled for 2 minutes. The lower layer is transferred into a centrifuge tube with a stopper and centrifuged at 2,500 ~ 3,000 rpm for about 10 minutes. The clear supernatant is transferred into a cell with a tight stopper (Test Solution). Separately, 25 mL of n-hexane is taken into a 50 mL separating funnel, where 5 mL of dimethyl sulfoxide is added, mixed by shaking vigorously for 2 minutes and settled for 2 minutes. The lower phase is centrifuged in a 10 mL centrifuge tube with a stopper at 2,500 ~ 3,000 rpm for 10 minutes. The clear supernatant is transferred into a cell with a tight stopper (Reference Solution). Absorption of the Test Solution is immediately measured with 1cm path length using the Reference Solution as a reference. The absorbance should not exceed 0.1 in at a wavelength range of 260 ~ 350 nm. N-hexane and dimethyl sulfoxide should be for UV absorption spectrophotometry.

(5) Readily Carbonizable Substances : 5 mL of Liquid Paraffin is taken into a Nestler tube, where 5 mL of

94.5~94.9% sulfuric acid. It is then heated for 2 minutes in a water bath. It is immediately taken out of the water bath and shaken (up and down) vigorously for 5 seconds. When this procedure is repeated 4 times, the color of the fluidal paraffin layer does not change color. The color of the layer of sulfuric acid should not be deeper than that of a solution that is prepared by mixing 3 mL of ferric chloride color standard solution, 1.5 mL of cobalt I chloride color standard solution, and 0.5 mL of copper sulfate color standard solution in a Nestler tube by shaking.

Locust Bean Gum

Carob Bean Gum

INS No.: 410

Synonyms: Carob bean gum; Algaroba gum

CAS No.: 9000-40-2

Definition Locust Bean Gum is obtained by crushing endosperm of legumes and locust bean (Ceratonia). Crushed endosperms are dissolved in hot water and filtered. By adding isopropyl alcohol, precipitates are formed. Major component is polysaccharide.

Compositional Specifications of Locust Bean Gum

Description Locust Bean Gum is white ~ pale yellowish brown powder or granule. It is odorless or has a characteristic odor.

Identification (1) 2 g of Locust Bean Gum is placed into a 400 mL beaker. It is then wetted with 4 mL of isopropyl alcohol. 200 mL of cold water is added with vigorously stirring. When the solution is homogenized by stirring continuously, it becomes white sticky solution.

(2) 100 mL of Test Solution in (1) is placed into a 400 mL beaker. When it is boiled for 10 minutes in a water bath, the viscosity increases significantly.

Purity (1) Arsenic : It should be no more than 4.0 ppm tested by Arsenic Limit Test.

(2) Lead : When 5.0 g of Locust Bean Gum is tested by Atomic Absorption Spectrophotometry or Inductively Coupled Plasma Emission Spectroscopy, its content should not be more than 2.0 ppm.

(3) Cadmium : When 5.0 g of Locust Bean Gum is tested by Atomic Absorption Spectrophotometry or Inductively Coupled Plasma Emission Spectroscopy, its content should not be more than 1.0 ppm.

(4) Mercury : When 0.1 g of Locust Bean Gum proceeded by Mercury Test Method, its content should not be more than 1.0ppm.

(5) Starch : 1 g of Locust Bean Gum is dissolved in 10 mL of water and is boiled, which is then cooled. When 2 drops of iodine TS are added, it should not turn blue.

(6) Isopropyl alcohol : 0.2 g of Locust Bean Gum is accurately weighed into a 300 mL round bottom flask, 200 mL of water is added, boiling chips and 1 mL of silicone resin are added and mixed well. Distillation column is connected to this, 4 mL of internal standard solution is taken into a 100 mL flask. While caring for the bubbles not to overflow, distill the solution at the rate of 2~3 mL per 1 minute until the milky liquid becomes about 90 mL, and water is added to make 100 mL, Test Solution. However, tert-butyl alcohol (1→1,000) is used as internal standard solution. Separately, 0.5 g of isopropyl alcohol is accurately weighed and water is added to make 500 mL, 2 mL of this solution and 4 mL of internal standard solution is taken again, water is added to make 100 mL, Standard Solution. 2 μ l of each of test solution and standard solution is taken respectively, and injected to gas

chromatograph with the following operation condition. Then, ratio of isopropyl alcohol peak against tert-butyl alcohol peak in test Solution and standard solution, Q_T and Q_S , is calculated separately, and the content of isopropyl alcohol is calculated by following formula, the content should not be more than 1.0%.

$$\text{Content of Isopropyl alcohol(\%)} = \frac{\text{Weight of isopropyl alcohol(g)}}{\text{Weight of sample(g)}} \times \frac{Q_T}{Q_S} \times \frac{2 \times 100}{500 \times 100} \times 100$$

Q_T : Ratio of isopropyl alcohol peak against tert-butyl alcohol peak in Test Solution

Q_S : Ratio of isopropyl alcohol peak against tert-butyl alcohol peak in standard solution

Operation Conditions

Column : PLOT Q or equivalent

Detector : Hydrogen Flame Ionization Detector (FID)

Injection Temperature : 200°C

Column Temperature : 120°C

Detector temperature : 300°C

Carrier gas : Nitrogen or Helium

(7) Total Viable Aerobic Count : When Locust Bean Gum is tested by Microbe Test Methods for Total Viable Aerobic Count (Number of General Germs) in General Test Method in 「Standards and Specifications for Foods」, it should not be more than 5,000 per 1 g.

(8) E. Coli : When Locust Bean Gum is tested by Microbe Test Methods for E. Coli in General Test Method 「Standards and Specifications for Foods」, it should be negative (-).

(9) Salmonella : When Locust Bean Gum is tested by Microbe Test Methods for Salmonella in General Test Method 「Standards and Specifications for Foods」, it should be negative (-).

(10) Number of Fungi : When Locust Bean Gum is tested by Microbe Test Methods for Number of Fungi in General Test Method in 「Standards and Specifications for Foods」, it should not be more than 500 per 1 g

Ash When it is tested for ash, the content should not be more than 1.2%.

Loss on Drying 3 g of Locust Bean Gum is dried for 5 hours at 105°C. The weight loss should not be more than 15%.

Protein When Locust Bean Gum is tested by Kjeldahl Method in Nitrogen Determination, the amount should not be more than 8%. (Protein Factor : 6.25).

Acid Insoluble substances 1.5 g of Locust Bean Gum is accurately weighed and dissolved in 150 mL of water and 1.5 mL sulfuric acid into a beaker, which is covered with a watch glass and heated for 6 hours in a water bath. Beaker wall is washed with water so that the residue doesn't remain on the wall. After

heating is complete, it is filtered through a glass filter (Glass filter is accurately weighed. 500 mg of appropriate filtering aid is added to the filter, which is then heated until the weight becomes constant.). The residue is washed thoroughly with hot water and dried for 3 hours at 105°C. The weight of the filtering aid is subtracted from the weight of the residue, which should not be more than 5%.

L-Lysine

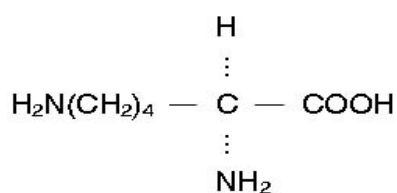

Chemical Formula: $\text{C}_6\text{H}_{14}\text{N}_2\text{O}_2$

Molecular Weight: 146.19

CAS No.: 56-87-1

Compositional Specifications of L-Lysine

Content L-Lysine, when calculated on the dried basis(anhydrous), should contain within a range of 97.0~103.0% of L-lysine ($\text{C}_6\text{H}_{14}\text{N}_2\text{O}_2$).

Description L-Lysine is white crystallite or crystalline powder with characteristic scent and taste.

Identification (1) 1 mL of ninhydrine solution (1→50) is added to 5 mL aqueous solution of L-Lysine (1→1,000). Upon heating for 3 minutes in a water bath, this solution turns reddish violet.

(2) L-Lysine solution is alkaline.

Purity (1) Clarity and Color of Solution : A solution of 1.0 g of L-Lysine in 40 mL of 1 N hydrochloric acid should be colorless and almost clear (or better).

(2) Specific Rotation : Precisely weighed 2 g of L-Lysine is dissolved in 6 N hydrochloric acid, where the total volume of the solution is 100 mL. Optical rotation of the solution is measured. When it is translated to dried material, specific rotation $[\alpha]_D^{20} = +23.3 \sim +29.3^\circ$

(3) Chlorides : When 0.07 g of L-Lysine is tested by Chloride Limit Test, the detected amount should not be more than the amount that corresponds to 0.2 mL of 0.01 N hydrochloric acid.

(4) Arsenic : It should be no more than 4.0 ppm tested by Arsenic Limit Test.

(5) Lead : When 5.0 g of L-Lysine is tested by Atomic Absorption Spectrophotometry or Inductively Coupled Plasma Emission Spectroscopy, its content should not be more than 5.0 ppm.

Water Content Water content in precisely weighed 0.2 g of L-Lysine is determined by back titration method in water determination (Karl-Fisher Titration) and should not be more than 8.0%.

Residue on Ignition When thermogravimetric analysis is done, the amount of residue should not be more than 0.2%.

Assay Approximately 0.2 g is precisely weighed and dissolved in 3 mL of formic acid, where 50 mL of glacial acetic acid (for non-aqueous titration) is added. This solution is titrated with 0.1 N perchloric acid solution (indicator : 1 mL of crystal violet buffered in glacial acetic acid). At the end point, the solution turns from violet to blue, then to green. Separately, a blank experiment is done following the

same procedure.

1 mL of 0.1 N perchloric acid solution = 7.310 mg $C_6H_{14}N_2O_2$

L-Lysine Monohydrochloride

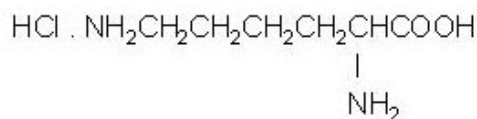

Chemical Formula: $\text{C}_6\text{H}_{14}\text{O}_2\text{N}_2 \cdot \text{HCl}$

Molecular Weight: 182.65

CAS No.: 657-27-2

Compositional Specifications of L-Lysine Monohydrochloride

Content L-Lysine Monohydrochloride, when calculated on the dried basis, should contain not less than 98.0% of L-lysine monohydrochloride ($\text{C}_6\text{H}_{14}\text{O}_2\text{N}_2 \cdot \text{HCl}$).

Description L-Lysine Monohydrochloride occurs as a white powder. It is odorless or has a light, characteristic odor and taste.

Identification (1) To 5 mL of a solution of L-Lysine Monohydrochloride (1→100), add 1 mL of ninhydrin solution, and heat for 3 minutes. The color of this solution becomes reddish purple.

(2) L-Lysine Monohydrochloride responds to the test for chloride in Identification.

Purity (1) Clarity and Color of Solution : When 0.5 g of L-Lysine Monohydrochloride is dissolved in 10 mL of water, the solution should be colorless and should not more than almost clear.

(2) Specific Rotation : Accurately weigh about 4 g of L-Lysine Monohydrochloride, precisely dried, and dissolve in 6N hydrochloric acid to make 50 mL. Optical rotation of this solution is measured and it should be $[\alpha]_D^{20} = +19.0 \sim +21.5^\circ$.

(3) Arsenic : It should be no more than 4.0 ppm tested by Arsenic Limit Test.

(4) Lead : When 5.0 g of L-Lysine Monohydrochloride is tested by Atomic Absorption Spectrophotometry or Inductively Coupled Plasma Emission Spectroscopy, its content should not be more than 5.0 ppm.

Loss on Drying When L-Lysine Monohydrochloride is dried for 3 hours at 105°C, the weight loss should not be more than 1%.

Residue on Ignition When thermogravimetric analysis is done with L-Lysine Monohydrochloride, the residue should not be more than 0.2%.

Assay Dissolve about 0.2 g of L-Lysine Monohydrochloride, previously dried and accurately weigh, in 3 mL of formic acid, add 50 mL of glacial acetic acid and 5 mL of mercury II acetate-glacial acetic acid solution (3→50), and titrated with 1N perchloric acid (indicator : 0.5 mL of α -naphthol benzene). The end point is where the solution changes its color from brown to green. Separately, a blank test is carried out by the same method.

1 mL of 0.1 N perchloric acid = 9.133 mg $\text{C}_6\text{H}_{14}\text{O}_2\text{N}_2 \cdot \text{HCl}$

Lysozyme

INS No.: 1105

Synonyms: Lysozyme hydrochloride; Muramidase

CAS No.: 12650-88-3

Definition Lysozyme is a thing obtained by treated white egg with alkalic solution and saline solution and refined resin, or an enzyme obtained by refined column or recrystallized after added salt. Dilutant or stabilizer can be added for the purpose of activity adjustment and quality preservation.

Compositional Specifications of Lysozyme

Description Lysozyme is white~dark brown powder, granule, paste or colorless~dark brown liquid.

Identification (1) 50 mg of Lysozyme is dissolved in 100 mL of phosphate buffer solution (pH 6.2). 2 mL of this solution is diluted 100 mL with phosphate buffer solution (pH 6.2). 2 mL of this solution is diluted 50 mL with phosphate buffer solution (pH 6.2), Test Solution. 3 mL each of substrate solution is taken into 2 test tubes, which are heated for 3 minutes at 35°C. Separately, Test Solution and phosphate buffer solution (pH 6.2) are heated for 3 minutes at 35°C. 3 mL of each is added to the previous test tubes, which is then allow to stand for 10 minutes at 35°C. Turbidity of the solution with Test Solution should less than that with phosphate buffer solution (pH 6.2).

(2) A solution (1→10,000) of Lysozyme dissolved in acetic acid-sodium acetate buffer solution (pH 5.4) shows a maximum absorption at 279 ~ 281 nm..

(3) When Lysozyme is proceeded as directed under Activity Test, it should have the activity as Lysozyme.

Purity (1) Clarity of Solution : 5 mL of an aqueous solution (1→100) of Lysozyme is taken. pH is adjusted to 3.0 with dilute hydrochloric acid if necessary. The transmittance of the resultant solution at 660 nm should be more than 80.0%.

(2) Arsenic : It should be no more than 1.3 ppm tested by Arsenic Limit Test.

(3) Lead : When 5.0 g of Lysozyme is tested by Atomic Absorption Spectrophotometry or Inductively Coupled Plasma Emission Spectroscopy, its content should not be more than 2.0 ppm.

(4) Mercury : When 0.1 g of Lysozyme is tested by Mercury Test Method, its content should not be more than 1.0 ppm.

(5) Chloride : Approximately 0.5 g of Lysozyme is accurately weighed and dissolved in 50 mL of water, where 0.1 mL of 10% potassium chromate solution is added. It is then titrated with 0.1 N silver nitrate solution. The content of chlorides (as chlorine) should not be more than 3.0%.

1 mL of 0.1 N silver nitrate solution = 3.545 mg Cl

(6) Nitrogen : When Lysozyme is tested by Kjeldahl Nitrogen Test in nitrogen determination method, the amount should be between 16.8 and 17.8%.

(7) Total Viable Aerobic Count : When Lysozyme is tested by Microbe Test Methods for Total Viable

Aerobic Count (Number of General Germs) in General Test Method in 「Standards and Specifications for Foods」, it should not be more than 5,000 per 1 g .

(8) E. Coli : When Lysozyme is tested by Microbe Test Methods for E. Coli in General Test Method 「Standards and Specifications for Foods」, it should be negative (-).

(9) Salmonella : When Lysozyme is tested by Microbe Test Methods for Salmonella in General Test Method 「Standards and Specifications for Foods」, it should be negative (-).

(10) Staphylococcus aureus : When Lysozyme is tested by Microbe Test Methods for Staphylococcus aureus in General Test Method 「Standards and Specifications for Foods」, it should be negative (-).

Water Content Water content of Lysozyme is determined by direct titration in water determination (Karl-Fisher Titration) and should not be more than 6.0%.

Residue on Ignition When Lysozyme is done with Residue on Ignition, the amount of residue should not be more than 1.5%.

Activity Test (Activity)

◦Preparation of Test Solution : 50 mg (activity) of Lysozyme is accurately weighed and dissolved in phosphate buffer solution (pH 6.2) (total volume 100 mL). 2 mL of this solution is diluted to 100 mL with in phosphate buffer solution (pH 6.2). 2 mL of the diluted solution is further diluted to 50 mL with in phosphate buffer solution (pH 6.2).

◦Preparation of Standard Solution : Amount of being equivalent to 50 mg (activity) lysozyme standard (drying loss is previously measured by the same method as the sample) is accurately weighed and dissolved in phosphate buffer solution (pH 6.2) to make volume 100 mL. 2 mL of this solution is diluted to 100 mL with in phosphate buffer solution (pH 6.2). 2 mL of the diluted solution is further diluted to 50 mL with in phosphate buffer solution (pH 6.2).

Test Procedure : 3 mL each of substrate solution is placed in three test tubes, which are heated for 3 minutes at 35°C. Separately, Standard Solution, Test Solution, and phosphate buffer solution are heated for 3 minutes at 35°C. Each solution is added to the previous 3 test tubes, which are then reacted for 10 ± 0.1 minutes at 35°C. Using water as a reference, absorbance at 640 nm is measured immediately (AS = Standard Solution, AT = Test Solution, and AO = phosphate buffer solution). The test is repeated three times and an average value is obtained. Activity of lysozyme is calculated from the following equation.

Activity of lysozyme mg(activity)/mg, as a dehydrated form

$$\text{Activity [mg(activity)/mg, as dried form]} = \frac{\text{weight of the standard [dried form, mg(activity)]}}{\text{weight of the sample [dried form (mg)]}} \times \frac{A_o - A_T}{A_o - A_s}$$

Solutions

◦ Phosphate Buffer Solution (pH 6.2)

Solution 1 : 10.4 g of sodium phosphate, monobasic is dissolved in water (total volume = 1,000 mL).

Solution 2 : 9.465 g of sodium phosphate, dibasic (anhydrous) is dissolved in water (total volume = 1,000 mL).

Solution 1 and Solution 2 (815 : 185) are mixed and pH is adjusted to pH 6.2.

◦ Acetic Acid Sodium Acetate Buffer Solution (pH 5.4)

Solution 1 : 13.6 g of sodium acetate is dissolved in water (total volume = 1,000 mL).

Solution 2 : 6 mL of glacial acetic acid is diluted to 1,000 mL with water.

Solution 1 and Solution 2 (800:100) are mixed and pH is adjusted to 5.4.

◦ Substrate Solution : Appropriate amount of dried biomass of *Micrococcus luteus* (*Micrococcus lysodeikticus*) is suspended in phosphate buffer solution (pH 6.2) by homogenizer. More phosphate buffer solution is added so that the transmittance at 640 nm becomes 10%. If there is a lot change in substrate, a calibration curve for the standard material is prepared and an optimum concentration in a straight line region is used. Usually, a straight line is observed in 0.2~0.6 $\mu\text{g}(\text{activity})/\text{mL}$ range.

Storage Standard of Lysozyme

Lysozyme should be stored in a hermetic container in a cold dark place.

Magnesium Carbonate

INS No.: 504(i)

Other names: Hydromagnesite

CAS No.: 546-93-0

Compositional Specifications of Magnesium Carbonate

Content Magnesium Carbonate should contain within a range of the equivalent of 40.0 ~ 44.0% of magnesium oxide (MgO = 40.32).

Description Magnesium Carbonate occurs as white, bulky powder or brittle lumps.

Identification To 0.2 g of Magnesium Carbonate, add gradually 3 mL of diluted hydrochloric acid. It dissolves while effervescence occurs. Add ammonia solution to make the solution alkaline. The solution responds to the test for Magnesium Salt.

Purity (1) Clarity and Color of Solution : 1 g of Magnesium Carbonate is dissolved in 10 mL of diluted hydrochloric acid (2→3), and add 10 mL of water. The solution should not be more than slightly turbid.
(2) Water Soluble Substances : To 2 g of Magnesium Carbonate, add 100 mL of freshly boiled and cooled water, boil, stirring, cool, filter, measure 50 mL of this solution evaporate to dryness in water bath, and dry the residue at 120°C for 3 hours. The amount should not be more than 10 mg.
(3) Arsenic : It should be no more than 4.0 ppm tested by Arsenic Limit Test.
(4) Lead : Magnesium Carbonate is tested by purity (2) for 「Sodium Metaphosphate」(not more than 2.0 ppm).
(5) Acid Insoluble substances : 5 g of Magnesium Carbonate is mixed with 75 mL of water, stirred, and dissolved by adding hydrochloric acid in small portion until it is not dissolved anymore. Boil for 5 minutes. The residue is filtered, washed with water until Chloride Ion is not detected, and ignited. The amount of the residue should not be more than 0.05%.
(6) Calcium Oxide : Approximately 0.6 g of Magnesium Carbonate is precisely weighed and dissolved in 35 mL of water and 6 mL of diluted hydrochloric acid (1→4), where 250 mL of water and 5 mL of tartaric acid solution (1→5). To this solution, 10 mL of triethanol amine solution (3→10) and 10 mL of potassium hydroxide solution (1→2) are added, which is then set-aside for 5 minutes. It is then titrated with 0.01 M EDTA solution(indicator : 0.1 g of 2-oxy-1-(2'-oxy-4'-sulfo-1'-naphthylazo)-3-naphthoic acid). The content of calcium oxide should not be more than 0.6%. End point is where the red color of the solution completely disappears and changes to blue. Separately a blank test is carried out.

1 mL of 0.01 M EDTA solution = 0.56 mg CaO

Assay Accurately weigh about 0.4 g of Magnesium Carbonate, dissolve in 10 mL of water and 3.5 mL of diluted hydrochloric acid (1→4), and add water to make exactly 500 mL. Measure exactly 25 mL of this

solution, add 50 mL of water and 5 mL of ammonia ammonium chloride buffer (pH 10.7), and titrate with 0.01 M EDTA (indicator : 0.04 g of a homogeneously ground mixture of 0.1 g of Eriochrome black T and 10 g of sodium chloride). Separately, perform a blank test in the same manner, make any necessary correction, and calculate the consumed volume as a mL. Take the consumed volume of 0.01 M EDTA obtained in Purity (6) as b mL, and calculate the amount by the following formula

$$\text{Amount of Magnesium Oxide(MgO)(\%)} = \frac{(a - 0.033b) \times 0.8061}{\text{weight of the sample(g)}}$$

Magnesium Chloride

Chemical Formula: $\text{MgCl}_2 \cdot 6\text{H}_2\text{O}$

Molecular Weight: 203.30

INS No.: 511

Synonyms: Magnesium chloride hexahydrate

CAS No.: 7786-30-3

Compositional Specifications of Magnesium Chloride

Content Magnesium Chloride should contain not less than 99.0% of magnesium chloride ($\text{MgCl}_2 \cdot 6\text{H}_2\text{O}$).

Description Magnesium Chloride occurs as colorless to white crystals, powder, fragments, granules, or crystalline lumps.

Identification Magnesium Chloride responds to the tests for Magnesium Salt and Chloride in Identification.

Purity (1) Clarity and Color of Solution : 1 g of Magnesium Chloride is dissolved in 10 mL of water. The turbidity of resulting solution should show slightly low level of turbid or better.

(2) Arsenic : It should be no more than 4.0 ppm tested by Arsenic Limit Test.

(3) Lead : Magnesium Chloride is tested by purity (2) for 「Sodium Metaphosphate」(not more than 2.0 ppm).

(4) Mercury : When Magnesium Chloride is tested by Mercury Limit Test, its content should not be more than 1.0 ppm.

(5) Zinc : Weigh 4 g of Magnesium Chloride, dissolve in water to make 40 mL, and use it as the test solution. Measure 30 mL of the test solution, add 5 drops of glacial acetic acid and 2 mL of potassium ferrocyanide solution (1→20), shake, and allow to stand for 10 minutes. The turbidity of this solution should not be more than the reference solution which is prepared by following method. Measure 14 mL of Zinc Standard Solution, and add 10 mL of the test solution and water to make 30 mL. Add 5 drops of acetic acid and 2 mL of potassium ferrocyanide solution (1→20), shake, and allow to stand for 10 minutes.

(6) Calcium : Weigh 0.5 g of Magnesium Chloride, and dissolve in water to make 50 mL. Take 5 mL of this solution, add 1 mL of ammonium oxalate solution, and allow to stand for 5 minutes. The solution should be ~~is~~ very slightly turbid or better.

(7) Ammonium ion : Dissolve 1 g of Magnesium Chloride in 90 mL water, and slowly add 10 mL of a freshly boiled and cooled solution of sodium hydroxide (1→10). Allow to settle, then decant 20 mL of the supernatant liquid into a Nessler tube, and dilute to 50 mL with water, Test Solution. Separately, transfer 48 mL of ammonium standard solution into Nessler tube and add 2 mL of the sodium hydroxide solution(1→10), Reference Solution. Add 2 mL of Nessler's TS to each test solution and reference solution and compare these colors. The color of test solution should not deeper than that

of reference solution (not more than 50 ppm).

Standard solution : 0.618 g of ammonium chloride is precisely weighed and dissolved in water to make 1,000 mL. 1 mL of this solution is weighed again, and water is added to make 1, 000 mL. (48 mL of this solution contains 10µg of Ammonium ion)

Assay Accurately weigh about 0.3 g of Magnesium Chloride, and dissolve in water to make exactly 100 mL. Take 20 mL of this solution, add 50 mL of water and 5 mL of ammonia-ammonium chloride buffer (pH 10.7). and titrate with 0.01 M EDTA (indicator : 2 drops of Eriochrome black T solution) until the red color of the solution changes to blue. Calculate the content by the following formula:

Consumed amount of 0.01M EDTA solution (mL) × 1.017

weight of the sample(g)

Content of Magnesium Chloride ($\text{MgCl}_2 \cdot 6\text{H}_2\text{O}$)(%) =

Magnesium Gluconate

Chemical Formula: $\text{MgCl}_2 \cdot 6\text{H}_2\text{O}$

Molecular Weight: 203.30

INS No.: 511

Synonyms: Magnesium chloride hexahydrate

CAS No.: 7786-30-3

Definition Magnesium Gluconate occurs as anhydrous, the dihydrate, or a mixture of both.

Compositional Specifications of Magnesium Gluconate

Content Magnesium Gluconate, when calculated on the dried basis(anhydrous), should contain within a range of 98.0 ~ 102.0% of Magnesium Gluconate ($\text{C}_{12}\text{H}_{22}\text{MgO}_{14}$)

Description Magnesium Gluconate occurs as a white to gray powder or granule. It is odorless.

Identification (1) Magnesium Gluconate solution (1→20) responds to the test for Magnesium Salt.

(2) Magnesium Gluconate is dissolved in water, heating in a water bath at 60°C if necessary, to obtain a test solution containing 10 mg/mL. 5 µl each of test solution and reference solution are applied on thin layer chromatographic plate coated with a 0.25 mm layer of silica gel. Develop the chromatogram in a solvent system until the solvent front has moved three-fourths of the length of the plate. Remove the plate from the developing bath, dry it at 110°C for 20 min, and allow to cool. After spraying with colorizing reagent, the plate is heated at 110°C for 10 min. The principal spot obtained from the test solution should correspond in R_f value, color, and size to that obtained from the reference solution.

Reference Solution: Prepare 10 mg/mL of Magnesium Gluconate standard as described for the test solution.

Developing Solvent: Ethyl alcohol: water: ammonium hydroxide: ethyl acetate (50:30:10:10)

Colorizing reagent: Dissolve 2.5 g of ammonium molybdate in about 50 mL of 2N sulfuric acid, add 1.0 g of ceric sulfate, swirl to dissolve, and dilute with 2N sulfuric acid to make 100 mL.

Purity (1) Lead : Transfer 10 g of Magnesium Gluconate, precisely weighed, into a crucible or a platinum dish. Add 5 mL of 25% sulfuric acid cautiously and mix well, which is then evaporated to dryness on a steam bath. Place the dish on a heating plate, preash slowly until most of sulfuric acid disappears, and then ash at 450~550°C. Repeat the above mentioned procedure when ashing is insufficient. Prepare sample blank by ashing 5 mL of 25% sulfuric acid under the same method. After ashing, add 5 mL of 1N hydrochloric acid and dry it on a steam bath. Add 1 mL of 3N hydrochloric acid and approximately 5 mL of distilled water and dissolve any residue on a steam bath. Transfer each solution quantitatively to a 10 mL volumetric flask, dilute to volume with distilled water, and mix. Dilute it if necessary. This solution is used for test solution. When the test solution is tested by Atomic Absorption Spectrophotometry or Inductively Coupled Plasma Emission Spectroscopy, its content should not be more than 2.0 ppm.

(2) Reducing Substances : Transfer 1 g of Magnesium Gluconate, accurately weighed, into a 250 mL Erlenmeyer flask, dissolve it in 10 mL of water, add 25 mL of alkaline cupric citrate solution, and cover the flask with a small beaker. Boil gently for exactly 5 min and cool rapidly to room temperature. Add 25 mL of diluted acetic acid (1→10), 10 mL of 0.1N iodine solution, 10 mL of dilute hydrochloric acid, and 3 mL of starch solution, and titrate with 0.1N sodium thiosulfate solution until the blue color disappears. The content of reducing substances should not be more than 1.0%.

$$\text{Content of reducing substances (as glucose)(\%)} = \frac{(V_1N_1 - V_2N_2) \times 27}{\text{weight of the sample(mg)}} \times 100$$

V_1 : Volume of 0.1N iodine solution (mL)

N_1 : Normality of 0.1N iodine solution

V_2 : Volume of 0.1N sodium thiosulfate solution (mL)

N_2 : Normality of 0.1N sodium thiosulfate solution

27 : An empirically determined equivalence factor for D-glucose

(3) Water Content : Water content of Magnesium Gluconate is determined by water determination (Karl-Fischer Method) and should not be more than 3.0~12.0%. Test solution should be kept for 30 minutes to dissolve prior to titration.

Assay Dissolve 0.8 g of Magnesium Gluconate, precisely weighed, in 20 mL of water, add 5 mL of ammonia-ammonium chloride buffer and 0.1 mL of eriochrome black, and titrate with 0.05M disodium EDTA to a blue endpoint.

$$1 \text{ mL of } 0.05 \text{ M disodium EDTA} = 20.73 \text{ mg of } \text{C}_{12}\text{H}_{22}\text{MgO}_{14}$$

Magnesium Hydroxide

Chemical Formula: Mg(OH)₂

INS No.: 528

Molecular Weight: 58.32

CAS No.: 1309-42-8

Compositional Specifications of Magnesium Hydroxide

Content Magnesium Hydroxide, when calculated on the dried basis, should contain within a range of 95.0 ~ 100.5% magnesium hydroxide [Mg(OH)₂].

Description Magnesium Hydroxide is voluminous white powder.

Identification Dilute hydrochloric acid is added to an aqueous solution (1→20) of Magnesium Hydroxide. The resulting solution responds to the test for magnesium salts in Identification.

Purity (1) Free Alkali and Soluble Salts : 2 g of Magnesium Hydroxide is added to 100 mL of water, which is heated for 5 minutes in a water bath and immediately filtered. After cooling, 50 mL of the filtrate is titrated with 0.1 N sulfuric acid . The consumed amount of 0.1 N sulfuric acid should not exceed 2 mL (indicator : methyl red solution). 25 mL of the filtrate is evaporated to dryness in a water bath and dried for 3 hours at 105°C. The amount of the residue should not be more than 10 mg.

(2) Lead : Magnesium Hydroxide is tested by purity (2) for 「Sodium Metaphosphate」(not more than 2.0 ppm).

(3) Arsenic : It should be no more than 4.0 ppm tested by Arsenic Limit Test.

(4) Calcium Oxide : Approximately 0.5 g of Magnesium Hydroxide is precisely weighed and dissolved in a mixture of 3 mL sulfuric acid and 22 mL water. After adding 50 mL of alcohol, the solution is set-aside over night. If necessary, the solution is heated to 50°C to dissolve magnesium sulfate crystals. A glass filter is previously washed with dilute sulfuric acid, water, and alcohol, heated to dry, and weighed. The solution is then filtered through the glass filter, which is washed with a mixture of 2 N sulfuric acid · alcohol (1:2). The glass filter is heated at 450 ± 25°C until the weight becomes constant. It is then cooled in a desiccator and weighed. The amount of calcium sulfate is obtained and the content is calculated from the following equation. The content should not be more than 1%.

$$\text{Content of calcium oxide(\%)} = \frac{\text{weight of calcium sulfate(mg)} \times 0.4119}{\text{weight of the sample(mg)}}$$

Loss on Drying

When Magnesium Hydroxide is dried for 2 hours at 105°C, the weight loss should not be more than 2.0%.

Loss on Ignition 0.5 g of Magnesium Hydroxide is slowly heat-treated to 800 ± 25°C in a platinum

crucible until the weight becomes constant, the weight loss should be within a range of 30.0 ~ 33.0%.

Assay Magnesium Hydroxide is dried for 2 hours at 105°C prior to use. 0.4 g of Magnesium Hydroxide is precisely weighed and dissolved in 25 mL of 1 N sulfuric acid. After adding methyl red solution, the excess acid is titrated with 1 N sodium hydroxide solution. The amount of consumed sulfuric acid is subtracted by the amount of sulfuric acid corresponding to calcium oxide in the sample. This value is the amount of magnesium hydroxide.

1 mL of 1 N sulfuric acid = 28.04 mg CaO

1 mL of 1 N sulfuric acid = 29.16 mg Mg(OH)₂

Magnesium L-Lactate

Magnesium di-L-lactate

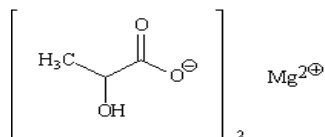

Chemical Formula: $\text{Mg}(\text{C}_3\text{H}_5\text{O}_3)_2 \cdot 2\text{H}_2\text{O}$

Molecular Weight: 238.48

INS No.: 329

Synonyms: Magnesium di-L-lactate

CAS No.: 18917-93-6

Compositional Specifications of Magnesium L-Lactate

Content Magnesium L-Lactate, when calculated on the dried basis, should contain within a range of 97.5 ~ 101.5% of Magnesium L-Lactate($\text{Mg}(\text{C}_3\text{H}_5\text{O}_3)_2$).

Description Magnesium L-Lactate occurs as white crystalline powder.

Identification (1) Magnesium L-Lactate is soluble in water when shaking for more than 30 min but insoluble in ethanol.

(2) Magnesium L-Lactate responds to the test for Magnesium Salt and Lactate in identification.

Purity (1) Specific Rotation : After drying, approximately 5 g of Magnesium L-Lactate is precisely weighed, which is dissolved in water to bring the total volume to 100 mL. Optical rotation of this solution should be within a range of $[\alpha]_D^{25} = -7.5 \sim -8.8^\circ$.

(2) Chloride : After drying, when 1 g of Magnesium L-Lactate is tested by Chloride Limit Test, its amount should not be more than the amount that corresponds to 0.3 mL of 0.01N hydrochloric acid.

(3) Arsenic: It should be no more than 4.0 ppm tested by Arsenic Limit Test.

(4) Lead : When 5.0 g of Magnesium L-Lactate is tested by Atomic Absorption Spectrophotometry or Inductively Coupled Plasma Emission Spectroscopy, its content should not be more than 2.0 ppm.

(5) Total Viable Aerobic Count : When Magnesium L-Lactate is tested by Microbe Test Methods for Total Viable Aerobic Count (Number of General Germs) in General Test Method in 「Standards and Specifications for Foods」, it should not be more than 1,000 per 1 g

(6) E. coli : When Magnesium L-Lactate is tested by Microbe Test Methods for E. coli in General Test Method 「Standards and Specifications for Foods」, it should be negative (-).

(7) Fungi : When Magnesium L-Lactate is tested by Microbe Test Methods for Fungi in General Test Method in 「Standards and Specifications for Foods」, it should not be more than 100 per 1 g.

Loss on Drying When Magnesium L-Lactate is dried at 120°C for 24 hr, the weigh loss should be within a range of 14.0~17.0%.

Assay Dissolve about 0.5g of Magnesium L-Lactate, precisely dried and accurately weighed, in 25mL of water. Add 5mL of ammonia-ammonium chloride buffer and 0.1mL of eriochrome black, and titrate with 0.05M EDTA solution until the solution is blue in color.

1 mL of 0.05M EDTA solution = 10.12 mg $\text{Mg}(\text{C}_3\text{H}_5\text{O}_3)_2$

Magnesium Oxide

Chemical Formula: MgO

INS No.: 530

Molecular Weight: 40.30

CAS No.: 1309-48-4

Compositional Specifications of Magnesium Oxide

Content Magnesium Oxide, when calculated on the dried basis by igniting, should contain not less than 96.0% of magnesium oxide (MgO).

Description Magnesium Oxide occurs as a white or whitish, bulky powder. Identification Dissolve 1 g of Magnesium Oxide in 25 mL of diluted hydrochloric acid (1→3). The solution responds to the test for Magnesium Salt.

Purity (1) Water-Soluble Substances : To 2.0 g of Magnesium Oxide, add 100 mL of water, heat in a water bath for 5 minutes. and immediately filter. Cool, measure 25 mL of the filtrate, evaporate to dryness in a water bath, and dry at 105°C for 1 hour. Weigh the residue. its content should not be more than 2.0%.

(2) Free Alkali : Take 50 mL of the filtrate of (1), add 2 drops of methyl red solution, and add 2.0 mL of 0.1 N sulfuric acid. This solution appears red color.

(3) Arsenic : It should be no more than 4.0 ppm tested by Arsenic Limit Test.

(4) Lead : Magnesium Oxide is tested by purity (2) for 「Sodium Metaphosphate」(not more than 2.0 ppm).

(5) Calcium Oxide : Take 50 mL of solution A prepared in Assay below, and add water to make 300 mL. Add 0.6 mL of tartaric acid (1→5), then 10 mL of triethanol amine (3→10) and 10 mL of potassium hydroxide solution (1→2). Allow to stand for 1 minute, titrate with 0.01 M EDTA, using a micro-burette (indicator: 0.1 g of 2-oxy-1-(2'-oxy-4'-sulfo-1'-naphthylazo)-3-naphthoesan solution), and express the consumed volume as B mL. The end point is observed when the red-purple color of the solution completely disappears and the solution becomes blue. (Not more than 1.5%)

$$\text{Content of calcium oxide(CaO)(\%)} = \frac{B(\text{mL}) \times 0.5608}{\text{weight of the sample(g)}}$$

Loss on Drying When Magnesium Oxide is dried at 800 ~ 825°C until the weight becomes constant, the weight loss should not be more than 5%.

Assay Accurately weigh about 0.5 g of Magnesium Oxide, previously ignited, add 5 mL of water, 10 mL of hydrochloric acid and 10 mL of perchloric acid, cover with a watch glass, and heat gradually. After thick white fumes are evolved, heat for another 10 minutes. Cool, add about 50 mL of hot water and 5 mL of diluted hydrochloric acid (1→2), heat slightly, and immediately filter through a filter paper for

quantitative analysis, and add water to the filtrate to make exactly 500 mL. Take this solution as solution A. Measure exactly 10 mL of solution A, add water to make 100 mL, add 5 mL of ammonia-ammonium chloride buffer and 2 drops of Eriochrome black T solution, immediately titrate with 0.01 M EDTA until the red color of the solution changes to blue, and determine the consumed volume as A mL. Using B mL of the consumed volume obtained in Purity (6), calculate the content by the following formular.

$$\text{Content of magnesium oxide (MgO) (\%)} = \frac{(A - 0.2B) \times 2.0152}{\text{weight of the sample(g)}}$$

Magnesium Phosphate, Dibasic

Dimagnesium Phosphate

Chemical Formula: $\text{MgHPO}_4 \cdot 3\text{H}_2\text{O}$

Molecular Weight: 174.33

INS No.: 343(ii)

Synonyms: Dimagnesium phosphate; Magnesium
hydrogen phosphate

CAS No.: 7782-75-4

Compositional Specifications of Magnesium Phosphate, Dibasic

Content Dimagnesium Phosphate is heat-treated and analyzed quantitatively. It should contain not less than 96.0% of magnesium pyrophosphate ($\text{Mg}_2\text{P}_2\text{O}_7$).

Description Dimagnesium Phosphate is scentless white crystalline powder.

Identification Proceed as directed under Identification for [Magnesium Phosphate, Tribasic].

Purity (1) Fluoride : 1 g of Dimagnesium Phosphate is precisely weighed and is tested by purity (8) for 「Calcium Citrate」, its content should not be more than 10 ppm.

(2) Arsenic : It should be no more than 4.0 ppm tested by Arsenic Limit Test.

(3) Lead : Dimagnesium Phosphate is precisely weighed and is tested by purity (2) for 「Sodium Metaphosphate」, its content should not be more than 2.0 ppm.

(4) Cadmium : Dimagnesium Phosphate is precisely weighed and is tested by purity (3) for 「Sodium Metaphosphate」, its content should not be more than 1.0 ppm.

(5) Mercury : When Dimagnesium Phosphate is tested by Mercury Limit Test, its content should not be more than 1.0 ppm.

Loss on Ignition When Dimagnesium Phosphate is heat-treated at 775~825°C until the weight becomes constant, the weight loss should be within a range of 15.0~36.0%.

Assay After heat-treating, 0.5 g of Dimagnesium Phosphate is precisely weighed and dissolved in a mixture of 50 mL water and 2 mL hydrochloric acid by heating. After cooling, the solution is diluted to 100 mL with water. 50 mL of the resulting solution is transferred into a 400 mL beaker and 100 mL of water is added, which is heated at 55~60°C. 15 mL of 0.1M EDTA solution is added and pH of the solution is adjusted to 10. After adding 10 mL of ammonia-ammonium chloride buffer solution, it is titrated with 0.1 M EDTA solution. The end point is where the color of the solution becomes to bluish violet from red. (Indicator : 12 drops of Eriochrome black solution).

$$\text{Content(\%)} = \frac{2 \times 11.13 \times V}{\text{weight of the sample(g)}}$$

V : Consumed amount of 0.1 M EDTA solution (mL)

Magnesium Phosphate, Tribasic

Trimagnesium Phosphate

Chemical Formula: $Mg_3(PO_4)_2 \cdot nH_2O$ (n=0,4,5 or 8)

Molecular Weight: 8hydrates 406.86

5hydrates 352.86

4hydrates 334.86

anhydrous 262.86

INS No.: 343(iii)

Synonyms: Trimagnesium phosphate

CAS No.: 7757-87-1(anhydrous)

Definition Magnesium phosphate, tribasic exists as crystals(8 hydrate, 5 hydrate and 4 hydrate) and anhydrous.

Compositional Specifications of Magnesium Phosphate, Tribasic

Content Trimagnesium Phosphate which is converted to a heat-treated material should contain not less than 98.0% tribasic magnesium phosphate [$Mg_3(PO_4)_2$].

Description Trimagnesium Phosphate is scentless tasteless white crystalline powder.

Identification (1) 0.2 g of Trimagnesium Phosphate is dissolved in 10 mL of dilute nitric acid. The solution should show the reaction (B) in Identification for Phosphates.

(2) 0.1 g of Trimagnesium Phosphate is dissolved in 0.7 mL of dilute acetic acid and 20 mL of water. 1 mL of ferric chloride solution is added to the solution, which is settled for 5 minutes and filtered. The filtrate responds to test of magnesium salts in Identification.

Purity (1) Fluoride : 1 g of Trimagnesium Phosphate is precisely weighed and is tested by purity (8) for 「Calcium Citrate」, its content should not be more than 5 ppm.

(2) Arsenic : It should be no more than 4.0 ppm tested by Arsenic Limit Test.

(3) Lead : Trimagnesium Phosphate is precisely weighed and is tested by purity (2) for 「Sodium Metaphosphate」, its content should not be more than 2.0 ppm.

Loss on Ignition 1 g of Trimagnesium Phosphate is heat-treated at 425°C until the weight becomes constant, the weight loss should be within a range of 15.0~23.0%, 20.0~27.0%, and 30.0~37.0% for 4 hydrate, 5 hydrate, and 8 hydrate.

Assay Approximately 0.2 g of Trimagnesium Phosphate is precisely weighed and dissolved in a mixture of 25 mL water and 10 mL dilute nitric acid. While keeping the solution at 50°C, 75 mL of ammonium molybdate solution is added while stirring occasionally and kept for 30 minutes. The resulting solution is set-aside for 16 hours or over night at room temperature. The resulting precipitates are washed 1 ~ 2 times with water(30 ~ 40 mL) and filtered. The precipitates and filter paper are washed with potassium nitrate solution (1→100) until the filtrate does not show acidity as determined with a litmus paper. The

precipitates are dissolved completely in 50 mL of 1 N sodium hydroxide solution by stirring. After adding 3 drops of phenolphthalein solution to the resulting solution, it is titrated with excess amount of 1 N sodium hydroxide solution.

1 mL of 1 N sodium hydroxide solution = 5.714 mg $\text{Mg}_3(\text{PO}_4)_2$

Magnesium Silicate

Synthetic Magnesium Silicate

INS No.: 553(i)

Synonyms: Synthetic magnesium silicate

CAS No.: 1343-88-0

Definition

Magnesium Silicate is a compound magnesium silicate of MgO : SiO₂ with a approximate mole ratio of 2 : 5.

Compositional Specifications of Magnesium Silicate

Content When Magnesium Silicate is converted to a heat treated material, it should contain not less than 15% of magnesium oxide (MgO) and not less than 67% of silicon dioxide (SiO₂).

Description Magnesium Silicate is scentless tasteless white fine powder.

Identification (1) 500 mg of Magnesium Silicate is dissolved in 10 mL of 2.7 N hydrochloric acid, which is then filtered. The filtrate is neutralized with 6 N ammonium hydroxide solution as determined by litmus paper. The resulting solution responds to test of magnesium salt in Identification

(2) Small amount of ammonium sodium phosphate is heated and melted to a bead on a platinum ring with a burner. This hot transparent bead is mixed with Magnesium Silicate and melted again. During cooling, opaque bead with a network structure appears and anhydrous silicate swells.

Purity (1) pH : pH of Magnesium Silicate solution should be within a range of 7.0 ~ 10.8.

(2) Fluoride : 1 g of Magnesium Silicate is precisely weighed into a beaker and dissolved by adding 10 mL of 1 N hydrochloric acid. It is then boiled for 1 minute. The solution is transferred into a PE beaker and quickly cooled. 15 mL of sodium citrate solution(1→4) and 10 mL of EDTA solution(1→40) are added, shaken, and mixed. pH of the solution is adjusted to 5.4 ~ 5.6 by adding hydrochloric acid(1→10) or sodium hydroxide solution(2→5). The total volume of the solution is brought up to 100 mL by adding water (Test Solution). 50 mL of the Test Solution is transferred into a PE beaker. Electric potential is measured using fluorine electrode . Fluoride concentration (µg/100mL) is measured from a standard curve and it should not be more than 10 ppm.

Standard Solution : 2.210 g of sodium fluoride, which is previously dried for 4 hours at 200°C, is accurately weighed into a PE beaker and dissolved in 200 mL of water. Then add water to bring the total volume to 1,000mL and preserve it in a PE beaker. Measure exactly 5 mL of this solution into a measuring flask, and add water to bring the total volume to 1,000 mL. (1 mL of this solution contains 5µg of fluorine.)

Calibration Curve Preparation : Separately, 1, 2, 3, 5, 10, and 15 mL of standard solution is weighed into a PE beaker, and 15 mL of Trisodium Citrate Solution (1→4) and 10 mL of Disodium Ethylenediaminetetraacetate solution (1→40) are added and mixed. To this solution, Hydrochloric acid

(1→10) or Sodium Hydroxide Solution (2→5) are added to bring the pH 5.4~5.6, where water is added to bring the total volume to 100mL, separately. Each of 50 mL of the solution transfer into a PE beaker. Then measure electric potential by using fluorine electrode and prepare calibration curve with the log of fluorine concentration.

(3) Soluble Salts : 150 mL of water is added to 10 g of Magnesium Silicate, which is heated for 15 minutes in a water bath. After cooling, water is added to bring the total volume to 150 mL. This mixture is settled for 15 minutes and filtered. 25 mL of water is added to 75 mL of the filtrate. 50 mL of the resulting solution is evaporated to dryness in a water bath. The residue is heat treated until the weight becomes constant. The residue should not exceed 75 mg (Not more than 3.0%).

(4) Free Alkali : When 2 drops of phenolphthalein solution is added to 20 mL of the filtrate in (3), it turns pale red. This solution is titrated with 0.1 N hydrochloric acid, the consumed amount of hydrochloric acid should not exceed 2.5 mL (Not more than 1% as NaOH).

(5) Arsenic : It should be no more than 4.0 ppm tested by Arsenic Limit Test.

(6) Lead : The test solution in (5) Purity is tested by Atomic Absorption Spectrophotometry or Inductively Coupled Plasma Emission Spectroscopy, its content should not be more than 5.0 ppm.

(7) Mercury : When Magnesium Silicate is tested by Mercury Limit Test, its content should not be more than 1.0 ppm

Loss on Drying When Magnesium Silicate is dried for 2 hours at 105°C, the loss should not be more than 15%, but applies to the anticaking agent only.

Loss on Ignition Magnesium Silicate is dried for 2 hours at 105°C and precisely weighed 1 g is analyzed by thermogravimetry at 900~1,000°C for 2 hours. Weight loss should not be more than 15%.

Assay (1) Magnesium Oxide : Approximately 1.5 g of Magnesium Silicate is precisely weighed into a 250 mL Erlenmeyer flask. 50 mL of 1 N sulfuric acid is added to the flask, which is heated for 1 hour in a water bath. After cooling, methyl orange solution is added and the excess amount of acid is titrated with 1 N sodium hydroxide solution.

$$1 \text{ mL of } 1 \text{ N sulfuric acid} = 20.15 \text{ mg MgO}$$

(2) Silicon Dioxide : Approximately 700 mg of Magnesium Silicate is precisely weighed into a 150 mL beaker. 20 mL of 1 N sulfuric acid is added to the beaker, which is then heated for 1 hour 30 minutes in a water bath. After cooling, the supernatant is filtered through a ash-free filter paper, which is washed slowly three times with hot water. 25 mL of water is added to the residue, which is heated for 15 minutes in a water bath. This is filtered and washed sufficiently with hot water. The filter paper with residue transfer into a platinum crucible and carbonized. It is then heat treated for 30 minutes. After cooling, the residue is weighed. The residue is wetted with small amount of water. After adding 6 mL of hydrofluoric acid and 3 drops of sulfuric acid, it is then evaporated to dryness. The resulting residue is heat treated for 5 minutes. After cooling, the remaining residue is weighed.

Magnesium Stearate

INS No.: 470(iii)

CAS No.: 557-04-0

Definition Magnesium Stearate is a mixture of magnesium stearate and palmitate.

Compositional Specifications of Magnesium Stearate

Content Quantitatively, Magnesium Stearate, when calculated, should contain within a range of 6.8~8.3% of magnesium oxide (MgO).

Description Magnesium Stearate is light powder with white color. It is odorless or has a unique slight scent.

Identification (1) To 1 g of Magnesium Stearate, add Hydrochloric acid (1→6), heat, and cool. After settling, liquid is separated into two layers. Upper layer is fatty acid and lower aqueous layer responds to test of Magnesium Salts in Identification.

(2) To 25 g of Magnesium Stearate, add 200 mL of hot water and 60 mL of dilute sulfuric acid and heat by stirring until clear supernatant is separated. Sulfate ions are completely washed away from this supernatant with water. This is heated in a water bath until water is separated so that the fatty acid becomes clear. After settling, aqueous layer is discarded. Fatty acid is melted by heating, which is then filtered. It is then dried for 20 minutes at 105°C. Solidification temperature of the fatty acid should not be less than 54°C.

Purity (1) Lead : When 5.0 g of Magnesium Stearate is tested by Atomic Absorption Spectrophotometry or Inductively Coupled Plasma Emission Spectroscopy, its content should not be more than 5.0 ppm.

(2) Chloride: Transfer Magnesium Stearate into round bottom flask, add 50 mL of diethyl ether which is not contain peroxide, 20 mL of dilute nitric acid, and 20 mL of water, attach a reflux condenser, and heat until it is dissolved completely. After cooling, transfer the content of flask into separating funnel, and mix by shaking. After settling, aqueous layer is separated. Titrate diethyl ether layer twice with 4 mL of water, combine the extracts, wash with 15 mL of diethyl ether, and add water to make 50 mL, Test Solution. When 10 mL of the test solution is tested by Chloride Limit Test, its content should not be more than the amount that corresponds to 1.4 mL of 0.02 N hydrochloric acid (not more than 0.10%).

(3) Sulfate : When 10 mL of test solution for purity(2) is tested by Sulfate Limit Test, its content should not be more than the amount that corresponds to 10.2 mL of 0.02 N sulfuric acid (not more than 1.0 %).

Loss on Drying 3 g of Magnesium Stearate is dried for 2 hours at 105°C until the weight becomes constant. Loss on drying should not be more than 4%.

Assay Accurately weigh about 1 g of Magnesium Stearate, add 50 mL of 0.1 N hydrochloric acid and boil for 30 minutes. Occasionally, water is added to maintain the liquid level. After cooling, the solution is filtered. Filtrate is thoroughly washed with water until it is no longer acidic. This water is added to the filtrate, which is then titrated with 1 N sodium hydroxide solution. 30 mL of 0.05 M EDTA solution, 5 mL of Ammonia-Ammonium Chloride buffer solution, and 0.15 mL of Eriochrome Black T (EBT) indicator solution are added to this test solution, which is then titrated with 0.05 M EDTA until it turns blue.

1 mL of 0.05 M EDTA Solution = 2.015 mg MgO

Magnesium Sulfate

Chemical Formula: $\text{MgSO}_4 \cdot n\text{H}_2\text{O}$ ($n=7$ or 3)

Molecular Weight: 7hydrates 246.48

3hydrates 174.41

INS No.: 518

Synonyms: Epsom salt (heptahydrate)

CAS No.: 7487-88-9

Definition Magnesium Sulfate occurs as crystals (heptahydrated) called Magnesium Sulfate (crystal) and a dried substance (trihydrated) called Magnesium Sulfate (anhydrous).

Compositional Specifications of Magnesium Sulfate

Content Magnesium Sulfate, when calculated on the dried basis by igniting, should contain not less than 99.0% of magnesium sulfate ($\text{MgSO}_4 = 120.39$).

Description Heptahydrate of Magnesium Sulfate is a colorless, column-shaped or needle-shaped crystal with a salty and bitter taste, and trihydrate is a white powder with salty and bitter taste.

Identification Magnesium Sulfate responds to the tests for Magnesium Salt and Sulfate in Identification.

Purity (1) Clarity and Color of Solution : When 1 g of Magnesium Sulfate is dissolved in 10 mL of water, the heptahydrate is colorless and should not be more than almost clear, and the trihydrate is colorless and should be slightly turbid or less.

(2) Chloride : When 1 g of Magnesium Sulfate is tested by Chloride Limit Test, its content should not be more than the amount that corresponds to 0.4 mL of 0.01 N hydrochloric acid.

(3) Arsenic : It should be no more than 4.0 ppm tested by Arsenic Limit Test.

(4) Lead : Magnesium Sulfate is tested by purity (2) for 「Sodium Metaphosphate」(not more than 2.0 ppm).

(5) Selenium : 0.2 g of Magnesium Sulfate is precisely weighed and is tested by purity (6) for 「Sulfuric acid」(not mer than 30 ppm).

(6) Iron : When the test solution in (4) Purity is tested by Atomic Absorption Spectrophotometry or Inductively Coupled Plasma Emission Spectroscopy, its content should not be more than 20 ppm.

Loss on Ignition When Magnesium Sulfate is dried for 2 hours at 100°C and ignite at $300 \sim 400^\circ\text{C}$ to constant weight, the weigh loss should be within a range of 40.0 ~ 52.0% for heptahydrate and 25.0~35.0% for trihydrate.

Assay Accurately weigh about 0.6 g of Magnesium Sulfate, previously ignited, and dissolve in 2 mL of diluted hydrochloric acid (1→4) and water to make exactly 100 mL. Measure exactly 25 mL of this solution, add 50 mL of water and 5 mL of ammonia-ammonium chloride buffer (pH 10.7), and titrate with 0.05 M EDTA solution (indicator : 5 drops of Eriochrome black T solution) until the red-purple color of the solution changes to blue. Separately, perform a blank test in the same manner.

1 mL of 0.05 M EDTA solution = 6.018 mg of MgSO_4

Maize Morado Color

Purple Corn Color

Synonyms: Purple corn color

INS No.: 163(iv)

Definition Maize Morado Color is a pigment obtained by extracting seeds of corn (*Zea mays* Linné of gramineae with water or ethyl alcohol. Its major pigment component is anthocyanin. Dilutant, stabilizer, or solvent can be added for the purpose of color value adjustment and quality preservation.

Compositional Specifications of Maize Morado Color

Content Color value ($E_{1\%}^{1\text{cm}}$) of Maize Morado Color should be more than the indicated value.

Description Maize Morado Color is dark red powder, paste, or liquid with a slight characteristic scent.

Identification (1) Test Solution obtained in Color Value section shows red color and a maximum absorption band near 515 nm.

(2) When Test Solution in (1) is alkalinized with sodium hydroxide solution (1→25), it becomes dark green.

Purity (1) Arsenic : It should be no more than 2.0 ppm tested by Arsenic Limit Test.

(2) Lead : When 5.0 g of Maize Morado Color is tested by Atomic Absorption Spectrophotometry or Inductively Coupled Plasma Emission Spectroscopy, its content should not be more than 8.0 ppm.

(3) FumonisinB₁: Weigh precisely 5 g which is converted to 30 of color value from indicated value of Maize Morado Color. Mix 80 mL solution of methanol-water(3:1) and add sodium hydroxide solution (1→10) to adjust pH 8~9. Add mixed solution of methanol-water(3:1) to make to 100 mL. Fill 2 g of trimethylaminopropylated silicagel in approximately 15 mm of glass or polypropylene column and wash the column the methanol and mixed solution of methanol-water(3:1) step by step. Add 10 mL of this solution in column and discard effluent. And wash the column with 20 mL of methanol-water(3:1) and 10 mL of methanol step by step. Elute with 20 mL mixed solution of methanol-acetic acid(99:1). Effluent is dried by reduced-pressurized drying below 40°C and dissolve in 0.2 mL of water-acetonitrile(1:1). After mixing respectively 0.1mL of test solution and standard solution with 0.1 mL of phthalaldehyde solution, in 1 minute test liquid chromatography under operation condition. Measure amount of FumonisinB₁ from calibration curve, it should not more than 0.3 ppm.

Standard solution: Weigh precisely 0.01 g of FumonisinB₁ and then dissolve in mixed solution of water-acetonitrile(1:1) to make to 100 mL. And respectively 1, 5, 10 mL of this solution with mixed solution of water-acetonitrile(1:1) make precisely to 200 mL to use as standard solution.

Preparation of calibration curve: Proceed liquid chromatography with 3 standard solutions under operation conditions below and prepare calibration curve.

Operation condition

Detector: Fluorescence detector (excitation wavelength 335 nm, fluorescence wavelength 440 nm)

Column filler: 5 μm of octadecylsilylated silicagel for liquid chromatography

Column tube: inner diameter 4.6 mm, length 15 cm stainless tube

Mobile phase: A solution: B solution = 3:7

A solution: phosphate buffer(Dissolve 12 g of sodium phosphate in water and make to 1,000 mL. Then adjust pH to 3.3 with phosphoric acid)

B solution: methanol

Assay (Color Value) Appropriate amount of Maize Morado Color is precisely weighted so that the absorption is within 0.3 ~ 0.7 and dissolved in acetic acid · sodium acetate buffer solution with pH 3.0 so that total volume is 100 mL (Test Solution). If necessary, the solution is centrifuged and the supernatant is used. Using acetic acid sodium acetate buffer solution with pH 3.0 as a reference solution, absorption A is measured at the maximum absorption near 515 nm with 1cm path length. Color value is obtained using the following equation.

$$\text{Color Value } (E_{1\text{cm}}^{10\%}) = \frac{A \times 10}{\text{weight of the sample(g)}}$$

• Citric acid · dibasic sodium phosphate buffer solution (pH 3.0)

Solution 1 : 0.1M citric acid solution : 1ℓ of solution containing 21.01 g of citric acid ($\text{C}_6\text{H}_8\text{O}_7 \cdot \text{H}_2\text{O}$).

Solution 2 : 0.2M dibasic sodium phosphate solution : 1ℓ of solution containing 71.63g of dibasic sodium phosphate ($\text{Na}_2\text{HPO}_4 \cdot 12\text{H}_2\text{O}$).

Solution 1 and Solution 2 are mixed well (159:41) and its pH is adjusted to 3.0.

DL-Malic Acid

d-L- Malic Acid

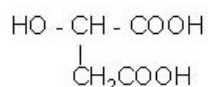

Chemical Formula: C₄H₆O₅

Molecular Weight: 134.09

INS No.: 296

Synonyms: 2-Hydroxybutanedioic acid

CAS No.: 6915-15-7

Compositional Specifications of DL-Malic Acid

Content DL-Malic Acid should contain not less than 99.0% of DL-malic acid (C₄H₆O₅).

Description DL-Malic Acid occurs as white crystals or crystalline powder. It is odorless or has a light, characteristic odor, and a characteristic acid taste.

Identification (1) Place 1 mL of DL-Malic Acid solution (1→20) into a test tube, add 2 ~ 3 mg of resorcinol and 1 mL of sulfuric acid, shake, heat at 120 ~ 132°C for 5 minutes, cool, and add water to make 5 mL. Make the solution alkaline by adding drop wise sodium hydroxide solution (2→5) while cooling, and add water to make 10 mL. A light blue fluorescence is observed under ultraviolet light.

(2) Place DL-Malic Acid solution (1→20) into a porcelain dish, neutralize with ammonia solution, add 10 mg of sulfanilic acid, and heat in a water bath for several minutes. Add 5 mL of sodium nitrite solution (1→5), warm slightly, and make alkaline with sodium hydroxide solution. It becomes to red.

Purity (1) Melting Point : Melting point of DL-Malic Acid should be within a range of 127 ~ 132°C.

(2) Clarity and Color of Solution : When 1 g of DL-Malic Acid is dissolved in 20 mL of water, it should be clear.

(3) Chloride : When 1 g of DL-Malic Acid is tested by Chloride Limit Test, its content should not be more than the amount that corresponds to 0.1 mL of 0.01 N hydrochloric acid.

(4) Arsenic : It should be no more than 4.0 ppm tested by Arsenic Limit Test.

(5) Lead : When 5.0 g of DL-Malic Acid is tested by Atomic Absorption Spectrophotometry or Inductively Coupled Plasma Emission Spectroscopy, its content should not be more than 2.0 ppm.

(6) Mercury : When DL-Malic Acid is tested by Mercury Limit Test, its content should not be more than 1.0 ppm.

(7) Readily Oxidized Matters : Weigh 0.1 g of DL-Malic Acid, dissolve in 25 mL of water and 25 mL of diluted sulfuric acid (1→20), keep at 20°C, and add 1 mL of 0.1 N potassium permanganate. The pink color of the solution should not disappear within 3 minutes.

Residue on Ignition When thermogravimetric analysis is done with DL-Malic Acid, the residue should

not be more than 0.05%.

Assay Accurately weigh about 1.5 g of DL-Malic Acid, and dissolve in water to make 250 mL. Take 25 mL of this solution, and titrate with 0.1 N sodium hydroxide (indicator : 2 drops of phenolphthalein solution).

1 mL of 0.1 N sodium hydroxide = 6.704 mg of $C_4H_6O_5$

D-Maltitol

Hydrogenated Maltose



Chemical Formula: $C_{12}H_{24}O_{11}$

Molecular Weight: 344.31

Synonyms: Hydrogenated maltose

INS No.: 965(i)

CAS No.: 585-88-6

Content Specifications of D-Maltitol

Content D-Maltitol should not contain less than 98.0% of D-Maltitol ($C_{12}H_{24}O_{11}$)

Description D-Maltitol is white crystallite with sweet taste.

Identification (1) D-Maltitol is readily soluble in water and lightly soluble in ethanol.

(2) Melting point of D-Maltitol should be in a range of 148 ~ 151°C.

(3) Accurately weigh about 5 g of D-Maltitol, and dissolve in water to make 100 mL. Optical rotation of this solution is measured and it should be within a range of $[\alpha]_D^{20} = +105.5 \sim +108.5^\circ$.

(4) 50 mg of D-Maltitol is dissolved in 20 mL of water, Test Solution. Each 2 μ l of Test solution and Reference solution is tested by thin layer chromatography. In this case, silica gel is used as a porous support material and development is stopped when the solvent front reaches approximately 17 cm. It is dried in air, where colorizing solution 1 is sprayed. It is set-aside in air for 15 minutes. Colorizing solution 2 is sprayed upon. The colorized spots are compared. Positions, colors, and sizes of the major spots from Test Solution should match those of reference solution.

Reference Solution : 50 mg of maltitol standard is dissolved in 20 mL of water.

Developing Solvent : propyl alcohol : ethyl acetate : water (70 : 20 : 10)

Colorizing Solution : 1. 0.2% sodium periodate

2. 2 g of tetramethylaminophenylmethane is dissolved in a mixture of glacial acetic acid · acetone (20:80) to make 100mL.

Purity

(1) Reducing Sugars : 7 g of D-Maltitol transfer into a 400 mL of beaker, add 35 mL of water, shake and add 50 mL of Fehling solution, which is then covered with a watch glass. It is heated so that the

content boils within 4 minutes and is boiled for 2 minutes. Deposited cupric oxide (Cu_2O) is filtered through a glass filter (previously weighed). It is then washed with hot water, ethanol and then ether. It is dried for 30 minutes at 100°C . It is again thoroughly washed with 10 mL of hot water, 10 mL of ethanol and then 10 mL of ether. It is dried for 1 hour at 100°C . The amount of cupric oxide should not be more than 20 mg.

(2) Chloride : When 10 g of D-Maltitol is tested by Chloride Limit Test, its content should not be more than the amount that corresponds to 1.5 mL of 0.01 N hydrochloric acid.

(3) Sulfate : When 10 g of D-Maltitol is tested by Sulfate Limit Test, its content should not be more than the amount that corresponds to 2 mL of 0.01 N sulfuric acid.

(4) Arsenic : It should be no more than 4.0 ppm tested by Arsenic Limit Test.

(5) Lead : When 5.0 g of D-Maltitol is tested by Atomic Absorption Spectrophotometry or Inductively Coupled Plasma Emission Spectroscopy, its content should not be more than 1.0 ppm.

(6) Nickel : When 5.0 g of D-Maltitol is tested by Atomic Absorption Spectrophotometry or Inductively Coupled Plasma Emission Spectroscopy, its content should not be more than 2.0 ppm.

Water Content When D-Maltitol is tested by Water Content Determination Method (Karl-Fischer Method), its content should not be more than 1%.

Residue on Ignition When thermogravimetric analysis is done with 2 g of D-Maltitol, the residue should not be more than 0.1%.

Assay Accurately weigh 1.5 g of D-Maltitol, transfer into a 100 mL volumetric flask, where water is added to completely dissolve the solid by stirring at a constant rate for 1 hour. Add water to make 100 mL in flask. The solution is filtered through a $0.45\ \mu\text{m}$ Millipore Filter, and the filtrate is used as the Test Solution. Separately, 0.5 g, 1.0 g, 1.5 g, and 2.0 g each of maltitol(quantitative analysis grade), precisely weighed, transfer into 100 mL volumetric flasks (for dissolving completely, stir at a constant rate for 1 hour). The solution is filtered through a $0.45\ \mu\text{m}$ Millipore Filter, and the filtrate is used as the Standard Solution. Liquid chromatography is carried out with $20\ \mu\text{l}$ of standard solutions under the following operation conditions and a calibration curve is prepared. The A of concentration (g/100 mL) of maltitol in Test Solution is obtained from the calibration curve, previously prepared from heights or areas of the peaks which are gained with $20\ \mu\text{l}$ of Test Solution. The content is calculated from the following equation.

$$\text{Content of Maltitol(\%)} = \frac{A \times 100}{\text{weight of the sample(g)}}$$

Operation Conditions

- Detector : Differential refractometer
- Column : AMINEX HPX 87C or its equivalent 30 cm x 8 mm
- Column Temperature : 85°C
- Mobile carrier Phase : water

-Flow Rate : 0.5 mL/min

Maltitol Syrup

Hydrogenated Glucose Syrup

Synonyms: Hydrogenated glucose syrup

INS No.: 965(ii)

Definition Maltitol Syrup is a maltitol mixture which contains sorbitol, hydrogenated oligosaccharide, and polysaccharide.

Compositional Specifications of Maltitol Syrup

Content Maltitol Syrup, when calculated on the dried basis(anhydrous), should contain not less than 99.0% of hydrogenated sugars, and more than 50.0% of maltitol.

Description Maltitol Syrup is colorless transparent gluey liquid or white crystalline lump. Maltitol Syrup has no scent but sweet taste.

Identification (1) Maltitol Syrup is readily soluble in water and slightly soluble in alcohol.

(2) 25~50 mg of Maltitol Syrup is dissolved in 20 mL of water (Test Solution). Test Solution is tested by the procedure Test (4) for 「D-Maltitol」 in Identification.

Purity (1) Reduced Sugars : Approximately 7 g of Maltitol Syrup is precisely weighed and tested by Purity (1) for 「D-Maltitol」. The content of cupric acid should not be more than 50 mg.

(2) Chloride : When 10 g of Maltitol Syrup is tested by Chloride Limit Test, the content should not be more than the amount that corresponds to 1.5 mL of 0.01 N hydrochloric acid.

(3) Sulfate : When 10 g of Maltitol Syrup is tested by Sulfate Limit Test, the content should not be more than the amount that corresponds to 2 mL of 0.01 N sulfuric acid.

(4) Lead : When 5 g of Maltitol Syrup is tested by Atomic Absorption Spectrophotometry or Inductively Coupled Plasma Emission Spectroscopy, its content should not be more than 1.0 ppm.

(5) Nickel : When 5.0 g of Maltitol Syrup is tested by Atomic Absorption Spectrophotometry or Inductively Coupled Plasma Emission Spectroscopy, its content should not be more than 2.0 ppm.

Water Content Water content of Maltitol Syrup is determined by water determination (Karl-Fisher Method) and should not be more than 31%.

Residue on Ignition When thermogravimetric analysis is done with 3 g of Maltitol Syrup, the amount of residue should not be more than 0.1%.

Assay (1) Content of total the hydrogenated saccharides (%)

$$= \frac{100 - [\text{Water}(\%) + \text{Residue on Ignition}(\%) + \text{Reduced saccharide}(\%)]}{100 - \text{water}(\%)} \times 100$$

$$\text{※ Reduced saccharide} = \frac{\text{Weight of dried copper oxides}(\text{mg})}{\text{weight of the sample}(\text{mg})} \times 100$$

(2) Maltitol : About 1 g of Maltitol Syrup is accurately weighed, to which water is added to make 50 mL. This solution is filtered with 0.45 μm paper to make the test solution. 20 μl each of the standard and test solutions are injected in liquid chromatography and the content of maltitol is determined by the following formula.

$$\text{Content of Maltitol(\%)} = \frac{\text{Sample weight of the standard(calculated on the dried basis(anhydrous))(g)}}{\text{Sample weight of the test body(calculated on the dried basis(anhydrous))(g)}} \times \frac{\text{Peak area of the test solution}}{\text{Peak area of the standard solution}} \times 100$$

Operation condition

- Column : Aminex HPX 87 (calcium type) or its equivalent
- Detector: Differential Refractometer (RI detector)
- Column temperature : 85°C
- Moving phase : water
- Flow speed : 0.5 mL/min
- Solution : 0.5 g of the maltitol standard is weighed accurately to put in 50 mL volumetric flask and water is added to make 50 mL (10 mg/mL).

Maltogenic Amylase

Definition Maltogenic Amylase is an enzyme obtained from a culture of *Bacillus subtilis* that contains amylase genes *Bacillus stearothermophilus*. Dilutant or stabilizer can be added for the purpose of activity adjustment and quality preservation.

Compositional Specifications of Maltogenic Amylase

Description Maltogenic Amylase is white ~ dark brown powder, particle, paste or colorless ~ dark brown liquid.

Identification When Maltogenic Amylase is proceeded as directed under Activity Test, it should have the activity as Maltogenic Amylase.

Purity (1) Arsenic : It should be no more than 4.0 ppm tested by Arsenic Limit Test.

(2) Lead : When 5.0 g of Maltogenic Amylase is tested by Atomic Absorption Spectrophotometry or Inductively Coupled Plasma Emission Spectroscopy, its content should not be more than 5.0 ppm.

(3) Coliform Group : When Maltogenic Amylase proceed as directed under Microbiological Methods for Coliform Group in General Testing Methods in 「Standards and Specifications for Foods」, it should not contain more than 30 per 1 g of this product.

(4) Salmonella : When Maltogenic Amylase proceed as directed under Microbiological Methods for Salmonella in General Testing Methods in 「Standards and Specifications for Foods」, it should be negative (-).

(5) E. Coli : When Maltogenic Amylase is tested by Microbe Test Methods for E. Coli in General Test Method 「Standards and Specifications for Foods」, it should be negative (-).

Activity Test (activity)

◦ Analysis Principle : Activity test is based on hydrolysis of maltoriose substrate at 37°C. Generated glucose is measured by using a mixture of Glucose dehydrogenase and NAD.

◦ Preparation of Test Solution : Sample is diluted with water so that 1 mL contains 0.015~0.075 MANU. Final diluted solution is prepared so that it contains 1% 1 M sodium chloride solution.

◦ Test Procedure : 0.5 mL of substrate solution is placed in a test tube, which is isothermalized in a 37 ± 1°C water bath. Exactly 0.5 mL of Test Solution is added to the test tube, which is mixed by shaking and set aside in a water bat. After exactly 30 minutes, the tube is taken out and the reaction is stopped by adding 1 mL of 0.06 N sodium hydroxide solution. 3 mL of GluDH solution is added to this solution, which is set aside for exactly 30 minutes at normal temperature. To this solution, 0.5 mL of substrate solution, 1 mL of 0.06 N sodium hydroxide solution, 0.5 mL of Test Solution are sequentially added. The resulting solution is set aside for 30 minutes (enzyme blank test solution). Using enzyme blank test solution as a reference solution, absorption of the test solution at 342 nm with 1 cm path length is measured and the concentration of glucose standard solution (μmol/L) is obtained from the standard curve.

Standard Curve

1.6 g of glucose is accurately weighted and dissolved in water (total volume = 1,000 mL). Using this solution, glucose standard solutions are prepared so that they contain 88.8 µmol/l, 177.6 µmol/l, 266.4 µmol/l, 355.2 µmol/l, 444.0 µmol/l, and 532.9 µmol/l of glucose. 2 mL of each standard solution is placed in a test tube, where 3 mL of GluDH solution is added. Set it aside for 30 minutes at room temperature. Absorption of each resulting solution is measured at 340 nm with 1cm path length using water as a reference. A standard curve of absorption versus concentration (µmol/l) of glucose standard solution is prepared.

Enzyme activity is obtained from the following equation.

$$\text{MANU/g} = \frac{A \times 4 \times F}{30 \times W \times 1,000}$$

A : Concentration of glucose standard solution (µmol/l) in Test Solution obtained from the standard curve

F : Dilution factor of test solution

4 : Ratio of the amount of glucose standard solution (2 mL) vs. the amount of Test Solution (0.5 mL) used in the test

30 : Reaction time (minutes)

W : Weight of sample (g)

1,000 : Conversion factor from µl to mL

Definition of Activity : 1 Maltogenic Amylase Novo Unit(MANU) corresponds to an amount of enzyme that decomposes 1 µmol of maltotriose under the test conditions above.

Solutions

- Citric Acid Buffer Solution : 0.225 g of citric acid is added in 20 mL of water. pH of this solution is adjusted to 5.0 with 4 N or 1 N sodium hydroxide solution. It is then diluted to 250 mL with water.
- Substrate Solution : 1 g of Maltotriose is added in citric acid buffer solution (total volume = 50 mL).
- 1 M Sodium Chloride Solution : 29.22 g of sodium chloride is added in water (total volume = 500 mL).
- 0.06 N sodium hydroxide solution : 30 mL of 1N sodium hydroxide solution is diluted to 500 mL with water.
- GluDH Solution : Use a mixed solution (Thermo Fisher Scientific Code. 981304, 981779 or its equivalent) contained Glucose dehydrogenase.

Storage Standards of Maltogenic Amylase

Maltogenic Amylase is strongly hygroscopic. Store in a cold dark place and well-closed containers.

Maltol



Chemical Formula: $C_6H_6O_3$

Molecular Weight: 126.11

INS No.: 636

Synonyms: 3-Hydroxy-2-methyl-4-pyrone

CAS No.: 118-71-8

Compositional Specifications of Maltol

Content Maltol should contain not less than 99.0% of maltol ($C_6H_6O_3$).

Description Maltol occurs as white to lightly yellowish needles or crystalline powder, having a sweet odor.

Identification (1) Dissolve 0.1 g of Maltol in 10 mL of ethanol, and add 3 drops of ferric chloride solution. The color becomes to red-purple.

(2) To 0.5 g of Maltol, add 10 mL of sodium hydroxide solution, and shake. It dissolves clearly. When pass carbon dioxide through the solution, white crystals are produced. Collect the crystals and recrystallize using 50% ethanol. The melting point should be within a range of 160 ~ 163°C.

(3) Dissolve 0.1 g of Maltol in 5 mL of dioxane, add 1 mL of sodium hydroxide solution, add iodine-potassium iodide solution while shaking until the color of iodine disappears, and heat in hot water for 5 minutes. Yellow crystals are deposited.

Purity (1) Melting Point : Melting point of Maltol should be within a range of 160 ~ 164°C

(2) Clarity and Color of Solution : When 0.1 g of Maltol is dissolved in 5 mL of 70% ethanol, the solution should be clear.

(3) Arsenic : It should be no more than 4.0 ppm tested by Arsenic Limit Test.

(4) Lead : When 5.0 g of Maltol is tested by Atomic Absorption Spectrophotometry or Inductively Coupled Plasma Emission Spectroscopy, its content should not be more than 2.0 ppm.

Loss on Drying When Maltol is dried for 4 hours in a vacuum desiccator (silica gel), the weight loss should not be more than 0.5%.

Residue on Ignition When thermogravimetric analysis is done with Maltol, the amount of residue should not be more than 0.2 %.

Assay Accurately weigh about 50 mg of Maltol, and dissolve in 0.1 N hydrochloric acid to make 250 mL. Take 5 mL of this solution, and add 0.1 N hydrochloric acid to make 100 mL, Test Solution. Separately, a standard solution is prepared by following the same procedure with standard of maltol. Measure the

absorbances of the test solution and the standard solution (express as A_u and A_s , respectively) at a wavelength of 274 nm, using 0.1 N hydrochloric acid as the reference solution. Calculate the content by the following formulas:

$$\text{Content of Maltol (C}_6\text{H}_6\text{O}_3\text{)(\%)} = C \times \frac{A_u}{A_s} \times \frac{1}{2 \times \text{weight of the sample(g)}}$$

C : Concentration of maltol in standard solution ($\mu\text{g/mL}$)

Maltotriohydrolase

G3 Producing Enzyme

Definition Maltotriohydrolase is an enzyme obtained from a culture of *Microbacterium imperiale*. Dilutant or stabilizer can be added for the purpose of activity adjustment and quality preservation.

Compositional Specifications of Maltotriohydrolase

Description Maltotriohydrolase is white ~ dark brown powder, particle paste or colorless ~ dark brown liquid.

Identification When Maltotriohydrolase is proceeded as directed under Activity Test, it should have the activity as Maltotriohydrolase.

Purity (1) Arsenic: It should be no more than 4.0 ppm tested by Arsenic Limit Test.

(2) Lead : When 5.0 g of Maltotriohydrolase is tested by Atomic Absorption Spectrophotometry or Inductively Coupled Plasma Emission Spectroscopy, its content should not be more than 5.0 ppm.

(3) Coliform group: Maltotriohydrolase is tested by Microbiological Methods for Coliform Group in section General Testing Methods in「Standards and Specifications for Foods」. It should contain no more than 30 per 1g of this product.

(4) Salmonella: Maltotriohydrolase is tested by Microbiological Methods for Salmonella in section General Testing Methods in 「Standards and Specifications for Foods」. It should be negative (-).

(5) E. Coli : When Maltotriohydrolase is tested by Microbe Test Methods for E. Coli in General Test Method 「Standards and Specifications for Foods」, it should be negative (-).

Activity Test (activity)

Preparation of Test Solution : Sample is diluted with calcium chloride.acetic acid buffer solution (pH 6.0) so that 1 mL of the solution contains 0.2~0.85 Unit.

Test Procedure : 0.5 mL of substrate solution and 0.4 mL of calcium chloride.acetic acid buffer solution (pH 6.0) are placed in a 50 mL volumetric flask, which is isothermalized in a $40 \pm 0.5^{\circ}\text{C}$ water bath for 10 minutes. Exactly 0.1 mL of Test Solution is added to the solution, mixed well by shaking, and set aside in a water bath. After exactly 15 minutes, 1 mL of alkaline copper solution is added to the solution, which is sealed and heated for exactly 20 minutes in a boiling water bath. Cool the solution, 1 mL of arsenic-ammonium molybdate solution is added and well mixed until red precipitates of cuprous oxide are completely dissolved. After setting aside for 20 minutes at room temperature, water is added to bring the total volume to 25 mL. Using water as a reference, the absorption (A_S) is measured at 520 nm with 1cm path length. Separately, as an enzyme blank test, 0.5 mL of substrate solution, 0.4 mL of calcium chloride acetate buffer solution (pH 6.0), 1 mL of alkaline copper solution, and 0.1 mL of Test Solution are well mixed and its absorption (A_B) is measured following the same procedure as the Test Solution.

Standard curve: Glucose is dried for 6 hours at 105°C . 1.0 g of dried glucose is precisely weighted and

dissolved in water (total volume = 100 mL). 1.0 mL, 2.0 mL, 3.0 mL, 4.0 mL, and 5.0 mL each of this solution is diluted to 100 mL with water. 1 mL of the each resulting solution contains 0.1 mg, 0.2 mg, 0.3 mg, 0.4 mg, and 0.5 mg each of glucose. 1 mL of each glucose standard solution is placed in a 50 mL Nestler cylinder, where 1 mL of alkaline copper solution is added and well mixed. It is sealed, heated in a boiling water bath for exactly 20 minutes, and cooled immediately. 1 mL of arsenic-ammonium molybdate solution is added and well mixed until red precipitates of copper suboxide are completely dissolved. After setting aside for 20 minutes at room temperature, water is added to bring the total volume to 25 mL. Using water as a reference, the absorbance of each standard solution is measured at 520 nm with 1cm path length. A standard curve of absorbance vs. the amount of glucose (mg) is prepared.

Enzyme activity is calculated by the following equation.

$$\text{Maltotriohydrolase (unit/g)} = (A_S - A_B) \times F \times \frac{1}{15} \times \frac{1.0}{0.1} \times \frac{1}{0.180} \times \frac{N}{W}$$

F : Amount of glucose (mg) when the difference in absorption is 1.0 (obtained from the standard curve).

15 : Reaction time (minutes)

0.1: Volume of Test Solution (mL)

0.180 : Coefficient of glucose/1 μ mole (glucose 1 μ mole = 0.180 mg)

N : Dilution volume of Test Solution

W : Weight of sample(g)

Definition of Activity: Maltotriohydrolase unit is an amount of enzyme that produces reducing sugar that corresponds to 1 μ mol of glucose per minute under the conditions above.

Solutions

Substrate Solution : 1.0 g of soluble starch is dispersed in 10 mL of water, where 50 mL of boiling water is slowly added while stirring. It is then boiled for 5 minutes. After cooling water is added to bring the total volume to 100 mL.

Calcium Chloride. Acetic acid Buffer Solution (pH 6.0) : Two solutions of 5 mM anhydrous calcium chloride in 0.1 M acetic acid and 0.1 M sodium acetate solution are prepared. These solutions are mixed and adjusted pH 6.0.

Alkaline Solution : 200 g of anhydrous sodium sulfate, 25 g of anhydrous sodium carbonate, 20 g of sodium bicarbonate, and 25 g of potassium sodium tartrate are dissolved in water to make 1,000 mL solution.

Copper Solution: 30 g of copper sulfate dissolve in 150 mL of water and apply 4 drops of sulfuric acid.

Mark up the volume of the content to 200 mL with water.

Alkaline Copper Solution: 25 mL of alkaline solution is mixed with 1 mL of copper solution. The solution is prepared before use.

Arsenic · Ammonium Molybdate Solution : 3 g of sodium arsenate, dibasic (7 hydrate) dissolve in 25 mL of water. 25 g of ammonium molybdate (4 hydrate) dissolve in 450 mL of water, where 21 mL of sulfuric acid is added. Sodium arsenate, dibasic solution is slowly added to ammonium molybdate solution while stirring. It is set aside for 24 hours at 37°C. It is stored in a brown bottle.

Storage standards of Maltotriohydrolase

Maltotriohydrolase is strongly hygroscopic, hence should be stored in a hermetic container in a cold dark place.

Manganese Chloride

Chemical Formula: $\text{MnCl}_2 \cdot 4\text{H}_2\text{O}$

Molecular Weight: 197.91

Synonyms: Manganese chloride tetrahydrate

CAS No.: 7773-01-5

Compositional Specifications of Manganese Chloride

Content Manganese Chloride should contain within a range of 98.0 ~ 102.0% of Manganese Chloride ($\text{MnCl}_2 \cdot 4\text{H}_2\text{O}$).

Description Manganese Chloride occurs as a pink translucent crystal having an irregular form.

Identification (1) Manganese Chloride solution (1→20) yield with ammonium sulfide solution a salmon-colored precipitate that is dissolved in acetic acid.

(2) Manganese Chloride solution (1→20) responds to the test by Chloride Limit Test.

Purity (1) pH: pH of Manganese Chloride solution (1→20), measured by glass electrode method, should be within a range of 4.0 ~ 6.0.

(2) Insoluble Matter: Approximately 20 g of Manganese Chloride is precisely weighed, dissolved in 200 mL of water, and allowed to stand on a steam bath. This solution is filtered through a tared sintered-glass crucible, washed thoroughly with hot water, and dried at 105°C for 1 hour. The weight should not be more than 0.005%.

(3) Substances Not Precipitated by Sulfide: 2 g of Manganese Chloride is dissolved in about 90 mL of water. After 4 mL of ammonium hydroxide is added, this solution is heated to 80°C and passed through hydrogen sulfide to completely precipitate the manganese. This solution is diluted to 100 mL, mixed, and allowed the precipitate to settle. The supernatant liquid is filtered, and 50 mL of the filtrate is evaporated to dryness in a tared platinum dish. 0.5 mL of sulfuric acid is added and ignited to constant weight. The weight should not be more than 0.2 %.

(4) Iron: 2 g of Manganese Chloride is dissolved in 20 mL of water. 1 mL of hydrochloric acid is added and diluted to 50 mL with water. 40 mg of ammonium persulfate and 3 mL of ammonium thiocyanate solution is added. Any red or pink color does not exceed that produced by 1 mL of iron standard solution (10 µg Fe) in an equal volume of a solution containing the quantities of the reagents used in the test (not more than 5 ppm).

(5) Sulfate Salts: 10 g of Manganese Chloride is dissolved in 100 mL of water. 1 mL of 2.7 N hydrochloric acid is added and filtered. After the solution is heated to boil, 10 mL of barium chloride solution is added, which is allowed to stand overnight. The precipitates are filtered, placed in a tared crucible, ignited at 600°C, and weighed. The amount of sulfate salts (as SO_4) should not be more than 0.005%. 1 mg of the residue corresponds to 0.412 mg of SO_4 .

(6) Lead : When 5.0 g of Manganese Chloride is tested by Atomic Absorption Spectrophotometry or Inductively Coupled Plasma Emission Spectroscopy, its content should not be more than 4.0 ppm.

Assay Approximately 4 g of Manganese Chloride is precisely weighed and dissolved in water to make 250 mL solution. 25 mL of this solution is mixed with 10 mL of hydroxyamine hydrochloride (1→10), 25 mL of 0.05 M disodium EDTA, 25 mL of ammonia-ammonium chloride buffer solution, and 5 drops of eriochrome black solution. Heat This solution is heated to 55 ~ 65°C and titrated from the buret to a blue end point with 0.05 M disodium EDTA.

1 mL of 0.05 M disodium EDTA = 9.896 mg of $\text{MnCl}_2 \cdot 4\text{H}_2\text{O}$

Manganese Citrate

Chemical Formula: $C_{12}H_{10}Mn_3O_{14} \cdot 10H_2O$

Molecular Weight: 723.17

Compositional Specifications of Manganese Citrate

Content Manganese Citrate, when calculated on the dried basis, should contain within a range of 96.5 ~ 104.8% of Manganese Citrate ($C_{12}H_{10}Mn_3O_{14} \cdot 10H_2O$).

Description Manganese Citrate occurs as a white to pale pink granule or powder.

Identification (1) Manganese Citrate solution (1→20) yield with ammonium sulfide solution a salmon-colored precipitate that is dissolved in acetic acid.

(2) Manganese Citrate solution responds to the test for citrate.

Purity (1) Sulfate : 10 g of Manganese Citrate is dissolved in 200 mL of water. Excess amount of hydrochloric acid is added and acidified (indicator: Methyl Red). After the solution is heated to boil, 10 mL of barium chloride solution is added, which is allowed to stand on a steam bath for 2 hour. The precipitates are filtered through a tared glass crucible, ignited at 600°C, and weighed. The amount of sulfate salts (as SO_4) should not be more than 0.02%. 1 mg of the residue corresponds to 0.412 mg

(2) Lead : Manganese Citrate is precisely weighed and is tested by purity

(3) Arsenic : It should be no more than 4.0 ppm tested by Arsenic Limit Test.

Loss on Drying When Manganese Citrate is dried for 16 hour at 105°C under vacuum, the loss should be within a range of 23 ~ 26%.

Assay Approximately 0.35 g of Manganese Citrate is precisely weighed and dissolved in 100 mL of water and 1 mL of dilute hydrochloric acid, followed by heating at 75 ~ 80°C. 25 mL of 0.5 M disodium EDTA is added to this solution. pH, if necessary, is adjusted to 10.0 ± 0.2 , and 10 mL of ammonia-ammonium chloride buffer solution and 8 drops of eriochrome black solution are added. This solution is titrated with 0.05 M disodium EDTA until a blue end point is persisted for 3 minutes.

1 mL of 0.05 M disodium EDTA = 9.05 mg of $C_{12}H_{10}Mn_3O_{14}$

Manganese Gluconate

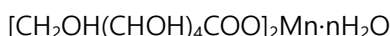

Chemical Formula: $\text{C}_{12}\text{H}_{22}\text{MnO}_{14}\cdot n\text{H}_2\text{O}$ ($n = 2$ or 0)

Molecular Weight: 481.27(2hydrates)
445.24(anhydrous)

CAS No.: 6485-39-8

Compositional Specifications of Manganese Gluconate

Content Manganese Gluconate, when calculated on the dried basis(anhydrous), should contain within a range of 98.0~102.0% of manganese gluconate ($\text{C}_{12}\text{H}_{22}\text{MnO}_{14}$).

Description Manganese Gluconate is pale red powder.

Identification (1) When ammonium sulfate solution is added to Manganese Gluconate solution (1→20), orange precipitates are formed. These precipitates is dissolved in acetic acid.

(2) Proceed as directed under Identification (2) for 「Sodium Gluconate」.

Purity (1) Lead : When 5.0 g of Manganese Gluconate is tested by Atomic Absorption Spectrophotometry or Inductively Coupled Plasma Emission Spectroscopy, its content should not be more than 2.0 ppm.

(2) Arsenic : It should be no more than 4.0 ppm tested by Arsenic Limit Test.

(3) Reduced Materials : Approximately 1 g of Manganese Gluconate is weighed into a 250 mL Erlenmeyer flask. 10 mL of water is added to dissolve the solid and 25 mL of alkaline copper citrate solution. A small beaker is placed on top of the flask, which is heated for precisely 5 minutes. It is then rapidly cooled to room temperature. To this solution, 25 mL of dilute acetic acid (1→10), 10 mL of 0.1 N iodine solution, 10 mL of dilute hydrochloric acid, and 3 mL of starch solution are added. The resulting solution is titrated with 0.1 N sodium thiosulfate solution until the blue color disappears. The content of reduced materials should not be more than 1.0%.

$$\text{Content of Reduced Materials(as glucose)}(\%) = \frac{(V_1N_1 - V_2N_2) \times 27}{\text{weight of the sample}(\text{mg})} \times 100$$

V_1 : Consumed amount of 0.1 N iodine solution (mL)

N_1 : Normality of 0.1 N iodine solution

V_2 : Consumed amount of 0.1 N sodium thiosulfate solution (mL)

N_2 : Normality of 0.1 N sodium thiosulfate solution

27 : Experimental corresponding amount for D-glucose

Water Content Water content of Manganese Gluconate is determined by water determination (Karl-Fisher Method) and should not be more than 3.0~9.0% and 6.0~9.0% for anhydrous and dihydrated,

respectively. Test Solution should be kept for 30 minutes at 50°C prior to titration.

Assay Dissolve approximately 0.7 g of Manganese Gluconate, accurately weighed, in 50 mL of water and add 1 g of ascorbic acid, 10 mL of ammonia ammonium chloride buffer solution, and 5 drops of Eriochrom black solution, which is titrated with 0.05 M EDTA solution until the color becomes deep blue.

1 mL of 0.05 M EDTA solution = 22.26 mg $C_{12}H_{22}MnO_4$

Manganese Sulfate

Chemical Formula: $\text{MnSO}_4 \cdot \text{H}_2\text{O}$

Molecular Weight: 169.01

CAS No.: 7785-87-7

Compositional Specifications of Manganese Sulfate

Content Manganese Sulfate should contain within a range of 98.0 ~ 102.0% of manganese sulfate ($\text{MnSO}_4 \cdot \text{H}_2\text{O}$).

Description Manganese Sulfate is odorless pale red granule or powder.

Identification (1) When ammonium sulfide solution is added to Manganese Sulfate solution (1→10), orange red precipitates are formed. When acetic acid is added, the precipitates redissolve.

(2) Manganese Sulfate solution (1→10) respond to the test for sulfate reaction in Identification.

Purity (1) Arsenic : It should be no more than 4.0 ppm tested by Arsenic Limit Test.

(2) Lead : Manganese Sulfate is tested by purity (2) for 「Sodium Metaphosphate」, it should be appropriate (not more than 4.0 ppm).

(3) Selenium : Dissolve 1 g of Manganese Sulfate in 100 mL of water (Test Solution). It is then tested by Cold Vapor Type of Atomic Absorption Spectrophotometry. The absorbance should not be bigger than that of Standard Solution, which is prepared by diluting 3 mL of selenium standard solution to 100 mL with water. (Not more than 30 ppm)

Loss on Ignition When Manganese Sulfate is heat treated at 400 ~ 500° until the weight becomes constant, the weigh loss should be within a range of 10 ~ 13%.

Assay 4 g of Manganese Sulfate is precisely weighed and dissolved in water to make 250 mL. 10 mL of hydrochloric acid hydroxylamine solution (1→10), 25 mL of 0.05 M EDTA solution, 25 mL of ammonia-ammonium chloride buffer solution, and 5 drops of eriochrome T black solution are added to 25 mL of this solution. While heating at 55 ~ 65°C, the solution is titrated with 0.05 M EDTA solution until it turns blue.

1 mL of 0.05 M EDTA = 8.450 mg of $\text{MnSO}_4 \cdot \text{H}_2\text{O}$

D-Mannitol

D-Mannite

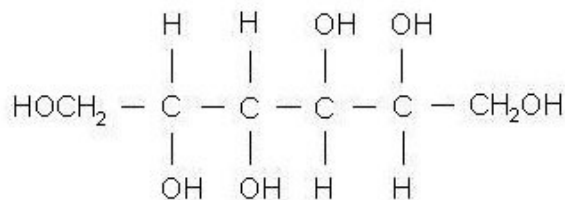

Chemical Formula: $\text{C}_6\text{H}_{14}\text{O}_6$

Molecular Weight: 182.2

Synonyms: D-Mannite

INS No.: 421

CAS No.: 69-65-8

Compositional Specifications of D-Mannitol

Content D-Mannitol, when calculated on the dried basis, should contain within a range of 96.0 ~ 102.0% of D-mannitol ($\text{C}_6\text{H}_{14}\text{O}_6$).

Description D-Mannitol occurs as white crystalline powder. It is odorless and has a sweet taste.

Identification (1) D-Mannitol is soluble in water, slightly soluble in alcohol, and insoluble in chloroform and ether.

(2) Melting point of D-Mannitol should be within a range of 165 ~ 169°C.

(3) When D-Mannitol is tested by Assay, it should show the peak at the same position as mannitol standard.

(4) 1 mL of ferric chloride solution is transferred into a Nestler tube, where 5 drops of saturated solution of D-Mannitol, Test Solution. Separately, a reference solution is prepared using 5 drops of water instead of the saturated solution. When 5 drops each of 5 N sodium hydroxide solution are added to both solutions, Test Solution yields a yellow precipitate while Reference Solution yields a brown precipitate. When both tubes are shaken vigorously, Test Solution becomes transparent but the brown color in Reference Solution persists. When more 5 N sodium hydroxide solution is added, no precipitate is observed in Test Solution but more precipitates are formed for Reference Solution.

Purity (1) Specific Rotation : Approximately 2.0 g of D-Mannitol and approximately 2.6 g of sodium borate are dissolved in 20 mL of water which is preheated to 30°C. It is then continuously stirred for 15 ~ 30 minutes without heating. When the solution becomes transparent, water is added to bring the volume to 25 mL. Optical rotation of the resulting solution should be within a range of $[\alpha]_D^{20} = +23 \sim +25^\circ$

(2) pH : To 10 mL of D-Mannitol solution (1→10), 0.5 mL of saturated potassium chloride solution is

added. pH of the resulting solution should be within a range of 5.0 ~ 8.0.

- (3) Chloride : 10 g of D-Mannitol is tested by Chloride Limit Test. The content should not be more than the amount that corresponds to 2.0 mL of 0.01 N hydrochloric acid.
- (4) Arsenic : It should be no more than 4.0 ppm tested by Arsenic Limit Test.
- (5) Sulfate : When 10 g of D-Mannitol is tested by Sulfate Limit Test, the amount should not be more than that corresponds to 2 mL of sulfuric acid.
- (6) Lead : When 5.0 g of D-Mannitol is tested by Atomic Absorption Spectrophotometry or Inductively Coupled Plasma Emission Spectroscopy, its content should not be more than 1.0 ppm.
- (7) Nickel : When 5.0 g of D-Mannitol is tested by Atomic Absorption Spectrophotometry or Inductively Coupled Plasma Emission Spectroscopy, its content should not be more than 2.0 ppm.
- (8) Reducing Sugar : Approximately 7 g of D-Mannitol is precisely weighed and tested by following the procedure in Purity (1) for 「D-Maltitol」. The content of cupric acid should not be more than 50 mg.
- (9) Total Sugar : 2.1 g of D-Mannitol is precisely weighed and transferred into a round bottom flask, where 40 mL of 0.1 N hydrochloric acid is added. A reflux condenser is attached to the flask. It is then heated for 4 hours in a water bath and cooled. The resulting solution is transferred into a 400 mL beaker. The round bottom flask is washed with 10 mL of water, which is added to the beaker. The solution is then neutralized with 6 N sodium hydroxide solution, where 50 mL of Fehling solution. The produced cupric oxide is filtered using a glass filter which is previously weighed. The precipitate is washed with hot water, alcohol, and ether. It is then dried for 30 minutes at 100°C. It is again washed with 10 mL each of hot water, alcohol, and ether. It is again dried for 1 hour at 100°C. The weight of cupric oxide should not be more than 50 mg.

Loss on Drying When D-Mannitol is dried for 4 hours at 105°C, the weight loss should not be more than 0.3%.

Residue on Ignition When thermogravimetric analysis is done with 2 g of D-Mannitol, the residue should not be more than 0.1%.

Assay 1.5 g of D-Mannitol is accurately weighed, to which water is added to make 100 mL. This solution is filtered with 0.45 μm paper to make the test solution. Separately, 0.5, 1.0, 1.5 g and 2.0 g of mannitol standard is weighed, to which water is added to make 100 mL and filtered with 0.45 μm paper to make the standard solution.

Test operation : inject the test solution and 20 μℓ standard solutions, each to liquid chromatography to calculate peak areas. Prepare standard curve with each peak area of 4 concentration of standard solutions(g/100mℓ), and calculate the concentration of Mannitol(g/100mℓ) in test solution from standard curve. Then calculate the content of Mannitol by the following equation.

$$\text{Content of D-mannitol (C}_6\text{H}_{14}\text{O}_6\text{) (\%)} = \frac{A \times 100}{\text{weight of the sample(g)}}$$

A: concentrate of mannitol in test solution calculated calibration procedure(g/100mL)

Operating conditions

- Column : Aminex HPX 87C(calcium form) or its equivalent
- Detector : Differential refractometer. (RI Detector)
- Column temperature : 85°C
- Mobile phase : Water.
- Flow rate : 0.5 mL/min.

Masticatory Substances, Natural

Definition There are Sorva (*Couma macrocarpa* BARB. RODR.), Sorvinha (*Couma utilis* MUELL.), Jelutong (*Dyera costulata* Hook. F. and *Dyera lowii* Hook. F.), Chicle (*Manikara zapotilla* Gilly and *Manikara chicle* Gilly), and Natural rubber (*Hevea brasiliensis*).

Compositional Specifications of Masticatory Substances, Natural

Description Masticatory Substance(Natural) is white ~ gray, pale brown ~ dark brown solid or viscoelastic solid with a slight characteristic scent.

Purity (1) Arsenic : It should be no more than 4.0 ppm tested by Arsenic Limit Test.

(2) Lead : When 5.0 g of General Provisions is tested by Atomic Absorption Spectrophotometry or Inductively Coupled Plasma Emission Spectroscopy, its content should not be more than 3.0 ppm.

***d*-Menthol**



Chemical Formula: $C_{10}H_{20}O$

Molecular Weight: 156.27

CAS No.: 1490-04-6

Compositional Specifications of *d*-Menthol

Content *d*-Menthol should contain not less than 98.0% of *d*-menthol ($C_{10}H_{20}O$).

Description *d*-Menthol occurs as colorless prisms or needles or as a white crystalline powder, having a scent like peppermint.

Identification (1) *d*-Menthol is mixed with an equal quantity of camphor or thymol, it becomes a liquid form.

(2) To 1 g of *d*-Menthol, add 20 mL of sulfuric acid, and shake. Yellowish red turbidity appears. After 24 hours, a transparent oily layer having no scent of menthol is separated.

Purity (1) Solidification Temperature : Solidification Temperature of *d*-Menthol should be within a range of 27 ~ 28°C.

(2) Thymol : To 0.2 g of *d*-Menthol, add to a cold mixture of 2 mL of acetic acid, 6 drops of sulfuric acid, and 2 drops of nitric acid. No color should develop.

(3) Specific Rotation : Approximately 2.5 g of *d*-Menthol is precisely weighed and dissolved in ethanol to make 25 mL. When Optical rotation of this solution is measured, it should be $[\alpha]_D^{20} = -2 \sim + 2^\circ$.

(4) Arsenic : It should be no more than 4.0 ppm tested by Arsenic Limit Test.

(5) Lead : When 5.0 g of *d*-Menthol is tested by Atomic Absorption Spectrophotometry or Inductively Coupled Plasma Emission Spectroscopy, its content should not be more than 2.0 ppm.

Assay Accurately weigh about 1 g of *d*-Menthol and test by Alcohol Content Measurement Method 2 in Flavoring Substances Test.

1 mL of 0.5 N alcoholic potassium hydroxide solution = 78.13 mg $C_{10}H_{20}O$

***l*-Menthol**



Chemical Formula: C₁₀H₂₀O

Molecular Weight: 156.27

CAS No.: 89-78-1

Compositional Specifications of *l*-Menthol

Content *l*-Menthol should contain not less than 98.0% of *l*-menthol (C₁₀H₂₀O).

Description *l*-Menthol occurs as colorless prisms or needles or as a white crystalline powder, having a peppermint like scent and a refreshing taste.

Identification (1) A solution of *l*-Menthol in ethanol (1→10) is levorotatory.

(2) Proceed as directed under Identification (1) and (2) in 「*d*-Menthol」.

Purity (1) Melting Point : Melting point of *l*-Menthol should be within a range of 42 ~ 43°C.

(2) Specific Rotation : Approximately 2.5 g of *l*-Menthol, precisely weighed, is dissolved in ethanol to make 25 mL. When Optical rotation of this solution is measured, it should be $[\alpha]_D^{20} = -45 \sim -51^\circ$.

(3) Thymol : To 0.2 g of *l*-Menthol, add a cold mixture of 2 mL of glacial acetic acid, 6 drops of sulfuric acid, and 2 drops of nitric acid. No color should develop.

(4) Arsenic : It should be no more than 4.0 ppm tested by Arsenic Limit Test.

(5) Lead : When 5.0 g of *l*-Menthol is tested by Atomic Absorption Spectrophotometry or Inductively Coupled Plasma Emission Spectroscopy, its content should not be more than 2.0 ppm.

Assay Accurately weigh about 1 g of *l*-Menthol and test by Alcohol Content Measurement Method 2 in Flavoring Substances Test.

1 mL of 0.5 N alcoholic potassium hydroxide solution = 78.13 mg C₁₀H₂₀O

DL-Methionine

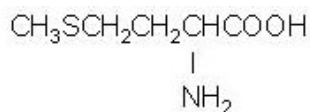

Chemical Formula: C₅H₁₁O₂NS

Molecular Weight: 149.21

CAS No.: 59-51-8

Compositional Specifications of DL-Methionine

Content DL-Methionine, when calculated on the dried basis, should contain within a range of 98.5 ~ 101.0% of DL-methionine (C₅H₁₁O₂NS).

Description DL-Methionine occurs as white flaked crystal or crystalline powder, and has a characteristic odor and a slightly sweet taste.

Identification (1) To 5 mL of DL-Methionine solution (1→1,000), add 1 mL of ninhydrin solution (1→1,000), and heat for 3 minutes. The color becomes purple.

(2) DL-Methionine solution (1→100) exhibits no optical activity.

(3) To 25 mg of DL-Methionine, add 1 mL of anhydrous cupric sulfate saturated sulfuric acid. The color becomes yellow.

(4) To 2 mL of DL-Methionine solution (1→100), add 2 mL of sodium hydroxide solution (1→25), and shake. Add 0.3 mL of sodium nitroprusside solution, and shake again. Allow to stand for 1-2 minutes, and add 4 mL of diluted hydrochloric acid (1→10). The color becomes reddish purple.

Purity (1) Clarity and Color of Solution : When 2 g of DL-Methionine is dissolved in 100 mL of water, the solution should be colorless and should not be more than almost clear.

(2) pH : pH of DL-Methionine solution (1→100) should be within a range of 5.6 ~ 6.1.

(3) Chloride : To 20 mL of the solution of (1) in Purity, add 6 mL of dilute nitric acid, Test Solution. When the test solution is tested by Chloride Limit Test, its content should not be more than the amount that corresponds to 0.4 mL of 0.01 N hydrochloric acid.

(4) Arsenic : It should be no more than 4.0 ppm tested by Arsenic Limit Test.

(5) Lead : When 5.0 g of DL-Methionine is tested by Atomic Absorption Spectrophotometry or Inductively Coupled Plasma Emission Spectroscopy, its content should not be more than 5.0 ppm.

Loss on Drying When DL-Methionine is dried for 4 hours at 105°C, the weight loss should not be more than 0.5%.

Residue on Ignition When thermogravimetric analysis is done with DL-Methionine, the residue should not be more than 0.1%.

Assay Dissolve 0.6 g of DL-Methionine, previously dried and accurately weighed, in water to make 100

mL. Transfer about 50 mL of the solution into a flask with a ground glass stopper, add 5 mL water, 5 g of dipotassium phosphate, 2 g of monopotassium phosphate, and 2 g of potassium iodide, and dissolve while shaking. To this solution, add 50 mL of 0.1 N iodine, seal tightly, shake well, allow to stand in a dark place for 30 minutes, and titrate the excess iodine with 0.1 N sodium thiosulfate solution (indicator : starch solution). Perform a blank test in the same manner.

1 mL of 0.1 N iodine = 7.461 mg of $C_5H_{11}O_2NS$

L-Methionine

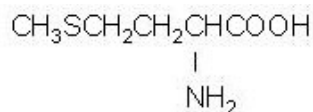

Chemical Formula: C₅H₁₁O₂NS

Molecular Weight: 149.21

CAS No.: 63-68-3

Compositional Specifications of L-Methionine

Content L-Methionine, when calculated on the dried basis, should contain within a range of 98.5 ~ 101.0% of L-methionine (C₅H₁₁O₂NS).

Description L-Methionine occurs as white flaked crystal or crystalline powder, having a characteristic odor and a slight bitter taste.

Identification (1) L-Methionine solution(1→100) is L-form. When it is acidified with hydrochloric acid, it becomes D-form.

(2) To 5 mL of L-Methionine solution (1→1,000), add 1 mL of ninhydrin solution (1→1,000), and heat for 3 minutes. The color becomes purple.

(3) To 25 mg of L-Methionine, add 1 mL of anhydrous cupric sulfate saturated sulfuric acid. The color becomes yellow.

(4) To 2 mL of L-Methionine solution (1→100), add 2 mL of sodium hydroxide solution (1→25), and shake. Add 0.3 mL of sodium nitroprusside solution, and shake again. Allow to stand for 1-2 minutes, and add 4 mL of diluted hydrochloric acid (1→10). The color becomes reddish purple.

Purity (1) Clarity and Color of Solution : 0.5 g of L-Methionine is dissolved in 20 mL of water. The solution should be colorless and should not be more than clear.

(2) pH : pH of L-Methionine solution (1→100) should be within a range of 5.6 ~ 6.1.

(3) Specific rotation : Dissolve 1 g of L-Methionine, previously dried for 4 hours and accurately weighed, in 6 N hydrochloric acid to make 50 mL. When Optical rotation of this solution is measured, it should be $[\alpha]_D^{20} = +21 \sim +25^\circ$.

(4) Chloride : To 20 mL of the solution(2 g of L-Methionine dissolved in 100 mL of water), add 6 mL of dilute nitric acid, Test Solution. When the test solution is tested by Chloride Limit Test, its content should not be more than the amount that corresponds to 0.4 mL of 0.01 N hydrochloric acid.

(5) Arsenic : It should be no more than 4.0 ppm tested by Arsenic Limit Test.

(6) Lead : When 5.0 g of L-Methionine is tested by Atomic Absorption Spectrophotometry or Inductively Coupled Plasma Emission Spectroscopy, its content should not be more than 5.0 ppm.

Loss on Drying When L-Methionine is dried for 4 hours at 105°C, the weight loss should not be more

than 0.5%.

Residue on Ignition When thermogravimetric analysis is done with L-Methionine, the residue should not be more than 0.1%.

Assay Proceed as directed under Assay in 「DL-Methionine」.

p-Methyl Acetophenone



Chemical Formula: C₉H₁₀O

Molecular Weight: 134.18

Synonyms: Methyl *p*-tolyl ketone; 1-Methyl-4-acetyl
benzene

CAS No.: 122-00-9

Compositional Specifications of *p*-Methyl Acetophenone

Content *p*-Methyl acetophenone should contain not less than 98.0% *p*-Methyl acetophenone (C₉H₁₀O).

Description *p*-Methyl acetophenone is transparent white ~ pale yellow liquid with a characteristic scent.

Identification *p*-Methyl acetophenone is proceed as directed under Liquid Film Method (4) in Infrared Spectrophotometry. There should be absorption bands at 1,680 cm⁻¹, 1,605cm⁻¹, 1,358cm⁻¹, 1,268cm⁻¹, and 815cm⁻¹.

Purity (1) Specific Gravity : Specific gravity of *p*-Methyl acetophenone should be within a range of 1.001~1.004.

(2) Refractive Index : Refractive Index n_D^{20} of *p*-Methyl acetophenone should be within a range of 1.532~1.535.

(3) Clarity and Color of Solution : When 1 mL *p*-Methyl acetophenone is dissolved in 10 mL of 50% alcohol, the solution should be clear.

(4) Chloride : When *p*-Methyl acetophenone is proceed as directed under Copper Screen Method in Halogenated Compounds in Flavoring Substances Test, it should be appropriate.

Assay Approximately 1 g of *p*-Methyl acetophenone is precisely weighed and proceed as directed under Method 2, Hydroxylamine Method, Determination of Aldehydes and Ketones in Flavoring Substances Test. However, heat treatment is done for 1 hour.

$$1 \text{ mL of } 0.5 \text{ N hydrochloric acid} = 67.07 \text{ mg C}_9\text{H}_{10}\text{O}$$

Methyl Alcohol

Methanol

Chemical Formula: CH₃OH

Molecular Weight: 32.04

Synonyms: Methanol; Carbinol

CAS No.: 67-56-1

Compositional Specifications of Methyl Alcohol

Content Methyl Alcohol should not be less than 99.85% of Methyl Alcohol (CH₃OH).

Description Methyl Alcohol is colorless, transparent, flammable liquid with a characteristic odor.

Purity (1) Solubility : 15 mL of Methyl Alcohol is mixed with 45 ml of water, this solution should be clear as the same amount of water after 1 hour.

(2) Acid Value (as formic acid) : To the mixture of 10 mL of ethyl alcohol and 25 mL of water, 0.5 mL of phenolphthalein solution is added, 0.02 N sodium hydroxide is added for at least 30 seconds until pale red persists. Then 19 mL (corresponds to 15 g) of Methyl Alcohol is added and mixed. It is titrated with 0.02N sodium hydroxide until pale red develops again, and the consumed amount should not be more than 0.25 mL. (indicator : 0.1 mL of phenolphthalein solution)

(3) Alkali Value(as ammonia) : 1 drop of Methyl red solution is added to 25 mL of water and 0.02 N sulfuric acid is added until red color develops. 29 mL of Methyl Alcohol(corresponds to about 22.5g) is added, titrated until the red color develops again, the consumption should not be more than 0.2 mL.

(4) Acetone and Aldehydes : To 1.25 mL of Methyl Alcohol (corresponds to about 1 g), 3.75 mL of water and 5.0 mL of Meyer solution are added, the turbidity of test solution should not be deeper than turbidity of standard solution containing 30µg of acetone (not more than 0.003%).

(5) Matters that reduce permanganates : 20 mL of Methyl Alcohol is cooled to 15°C, and transferred to a cylinder with a stopper. After adding 0.1 mL of 0.1 N potassium permanganate solution, it is set aside for 5 minutes. Pale red color should not disappear completely.

(6) Lead : When 5.0 g of Methyl Alcohol is tested by Atomic Absorption Spectrophotometry or Inductively Coupled Plasma Emission Spectroscopy, its content should not be more than 2.0 ppm.

(7) Distillation test : When Methyl Alcohol is tested for boiling point and amount of distillate, 95%(v/v) or more should be extracted at 63.6 ~ 65.6°C.

(8) Carbonized substances : To 25 mL of Methyl Alcohol, 25 mL of sulfuric acid solution to make 10°C is added and mixed, and the color of the solution should not be deeper than that of the solution, which is made by adding water to 3.5 mL of platinum-cobalt solution to make 50 mL.

Platinum-cobalt solution : To 1.246 g of Potassium chloroplatinate(K₂PtCl₆) and 1.00 g of cobalt

chloride($\text{COCl}_2 \cdot 6\text{H}_2\text{O}$), 200 mL of water and 100 mL of hydrochloric acid are added, dissolved, and water is added to make 1,000 mL.

(9) Residue on Evaporation : 125 mL (approximately 100 g) of Methyl Alcohol is dried in a water bath, further dried for 30 minutes at 105°C and cooled. The weight of the residue should not be more than 10 ppm.

Water Content Water content of Methyl Alcohol is determined by water determination (Karl-Fischer Method) and should not be more than 0.1%.

Assay The content of Methyl Alcohol is tested by determination of specific gravity. It should not be more than 0.7928 as specific gravity.

Methyl Anthranilate



Chemical Formula: $C_8H_9NO_2$

Molecular Weight: 151.16

Synonyms: Methyl *o*-aminobenzoate

CAS No.: 134-20-3

Compositional Specifications of Methyl Anthranilate

Content Methyl Anthranilate should contain not less than 98.0% of methyl anthranilate ($C_8H_9NO_2$).

Description Methyl Anthranilate occurs as colorless to light yellow lumps or liquid. It has a characteristic odor. The liquid shows a characteristic fluorescent blue-purple color.

Identification (1) Dissolve 0.1 g of Methyl Anthranilate in hydrochloric acid (1→10). Add 1 mL of sodium nitrite solution and 2 mL of the solution prepared by dissolving 0.1 g of β -naphthol in 5 mL of sodium hydroxide solution. An orange-red precipitate is formed.

(2) To 1 g of Methyl Anthranilate, add 5 mL of 10% alcoholic solution of potassium hydroxide, and heat in a water bath. Add 5 mL of water while hot. After cooling, add 4 mL of diluted hydrochloric acid. A white to gray~white precipitate is formed.

Purity (1) Solidification Point : Solidification Point of Methyl Anthranilate should not be less than 23.8°C.

(2) Clarity and Color of Solution : 1 mL of Methyl Anthranilate is melted at 30°C by warming, and dissolved in 6 mL of 60% ethanol. This solution should be clear.

(3) Refractive Index : Refractive Index n_D^{20} of Methyl Anthranilate should be within a range of 1.582 ~ 1.584.

(4) Acid Value : Acid value of Methyl Anthranilate is tested by Acid Value in Flavoring Substance Test. It should not be more than 1.

Assay Accurately weigh about 0.5 g of Methyl Anthranilate, and proceed as directed under Ester Value and Ester Content in Flavoring Substances Tests.

1 mL of 0.5 N ethanolic potassium hydroxide = 75.58 mg of $C_8H_9NO_2$

Methyl Cellulose

INS No.: 461

Synonyms: Cellulose methyl ether

CAS No.: 9004-67-5

Compositional Specifications of Methyl Cellulose

Content Methyl Cellulose, when calculated on the dried basis, should contain within a range of 25.0 ~ 33.0% of methoxyl group ($-\text{OCH}_3 = 31.04$).

Description Methyl Cellulose occurs as a white to whitish powder or fibrous substance. It is odorless.

Identification To 1 g of Methyl Cellulose, add 100 mL of water at about 70°C. Stir well, cool while shaking, and allow to stand in a cold place until it becomes a uniformly pasty solution. Use this solution as the test solution.

(1) Heat 10 mL of the test solution in a water bath. White turbidity appears or a white precipitate is formed. After cooling, the white turbidity or precipitate dissolves and becomes a uniformly pasty solution again.

(2) Transfer 2 mL of the test solution into test tube, superimpose 1 mL of anthrone solution gently along the tube wall. The color of the junction changes to a blue to green color.

Purity (1) Viscosity : When the viscosity is expressed, perform the following test. The viscosity is 80 ~ 120% of the expressed amount when the expressed amount is not more than 100 centistokes, and 75-140% when it exceeds 100 centistokes. Accurately weigh the amount of Methyl Cellulose corresponding to 2 g calculated on the dried basis, add 50 mL of water at 85°C and stir for 10 minutes, using a stirrer. Add 40 mL of water, dissolve the sample in ice water while stirring for 40 minutes, add water to make exactly 100 mL, remove the effervescence by centrifuging if necessary, and measure the viscosity at $20 \pm 0.1^\circ\text{C}$.

(2) Chloride : 0.5 g of Methyl Cellulose transfer into a beaker. add 30 mL of hot water, stir well, and filter while hot with an insulated funnel. Wash the beaker and the residue on filter paper, using 15 mL of hot water each time, 3 times, combine the filtrate and the washings, and add water to make 100 mL. Use this solution as the Solution A. Add 6 mL of dilute nitric acid to 5 mL of Solution A, as the Test Solution. Test this solution by Chloride Limit Tests. Its content should not be more than the amount that corresponds to 0.4 mL of 0.01 N hydrochloric acid.

(3) Sulfate : To 40 mL of Solution A in (2) above, add 1 mL of dilute hydrochloric acid. which is then tested by Sulfate Limit Test. Its content should not be more than the amount that corresponds to 0.4 mL of 0.01 N sulfuric acid.

(4) Arsenic : It should be no more than 4.0 ppm tested by Arsenic Limit Test.

(5) Lead : When 5.0 g of Methyl Cellulose is tested by Atomic Absorption Spectrophotometry or

Inductively Coupled Plasma Emission Spectroscopy, its content should not be more than 2.0 ppm.

(6) Cadmium : When 5.0 g of Methyl Cellulose is tested by Atomic Absorption Spectrophotometry or Inductively Coupled Plasma Emission Spectroscopy, its content should not be more than 1.0 ppm.

(7) Mercury : When Methyl Cellulose is tested by Mercury Limit Test, its content should not be more than 1.0 ppm.

Loss on Drying When Methyl Cellulose is dried for 4 hours at 105°C, the weight loss should not be more than 5%.

Residue on Ignition When thermogravimetric analysis is done with 1 g of Methyl Cellulose, previously dried for 4 hours at 105°C, the residue should not be more than 1.5%.

Assay Accurately weigh about 25 mg of Methyl Cellulose, previously dried, and proceed as directed under Methoxyl Determination.

$$\text{Content(\%)} = \frac{\text{Weight of 0.1N sodium thiosulfate solution (mL)} \times 0.5172}{\text{weight of the sample(mg)}} \times 100$$

Methyl Cinnamate



Chemical Formula: $C_{10}H_{10}O_2$

Molecular Weight: 162.19

Synonyms: Methyl 3-phenylpropenoate

CAS No.: 103-26-4

Compositional Specifications of Methyl Cinnamate

Content Methyl Cinnamate should contain not less than 98.0% of methyl cinnamate ($C_{10}H_{10}O_2$)

Description Methyl Cinnamate occurs as a white to light yellow solid having a matsutake like odor.

Identification To 1 g of Methyl Cinnamate, add 10 mL of 10% alcoholic solution of potassium hydroxide, and heat in a water bath. Methyl Cinnamate dissolves, a white precipitate is formed, and the matsutake like odor disappears. Add 10 mL of water while warm. The precipitate dissolves. Acidify with diluted sulfuric acid. A white crystalline precipitate is formed.

Purity

(1) Solidification Temperature : Solidification temperature should not be less than 33.8°C.

(2) Clarity and Color of Solution : When 1 g of Methyl Cinnamate is dissolved in 4 mL of 80% ethanol by heating at 40°C, the solution should be almost clear.

(3) Acid Value : Acid value of Methyl Cinnamate is tested by Acid Value in Flavoring Substance Test. It should not be more than 2.

Assay Accurately weigh 1 g of Methyl Cinnamate tested by Ester Value in Flavoring Substances Test. In this case, 5 mL of water is added before heating.

1mL of 0.5 N alcoholic solution of potassium hydroxide = 81.10 mg $C_{10}H_{10}O_2$

Methyl Hesperidin

Compositional Specifications of Methyl Hesperidin

Content Methyl Hesperidin when calculated on the dried basis, should contain not less than 90.0% of methyl hesperidin.

Description Methyl Hesperidin occurs as a yellow to orange-yellow powder. It is odorless or has a slight odor.

Identification (1) To 10 mg of Methyl Hesperidin, add 2 mL of sulfuric acid. A red color develops. Add 1 ~ 2 drops of hydrogen peroxide solution. A dark red color develops.

(2) To 0.1 g of Methyl Hesperidin, add 5 mL of ethanol and 1 mL of sodium hydroxide solution, boil for 3 minutes, cool, and filter. The color of the filtrate changes to yellow to orange-yellow. To the filtrate, add 1 mL of hydrochloric acid and about 10 mg of magnesium dust, and allow to stand. A pink color develops.

(3) To 0.1 g of Methyl Hesperidin, add 10 mL of diluted hydrochloric acid, boil for 5 minutes, cool, and filter. Neutralize the filtrate with sodium hydroxide solution (1→5), add 2 mL of Fehling's solution, and heat. A red precipitate is formed.

Purity (1) Clarity and Color of Solution : When 1 g of Methyl Hesperidin is dissolved in 10 mL of water, the solution should not be more than almost clear.

(2) Sulfate : When 0.5 g of Methyl Hesperidin is tested by Sulfate Limit Test, the content should not be more than the amount corresponding to 0.2 mL of 0.01 N sulfuric acid.

(3) Lead : When 5.0 g of Methyl Hesperidin is tested by Atomic Absorption Spectrophotometry or Inductively Coupled Plasma Emission Spectroscopy, its content should not be more than 2.0 ppm.

Loss on Drying When Methyl Hesperidin is dried for 24 hours in a vacuum desiccator (silica gel), the weight loss should not be more than 3%.

Residue on Ignition Residue on ignition of Methyl Hesperidin should not be more than 0.5%.

Assay Accurately weigh about 0.3 g of Methyl Hesperidin, previously dried, dissolve in water to make 1,000 mL. Take 10 mL of this solution, add water to make 100 mL, measure absorbance A at a wavelength of 300 nm with 1 cm path length, and calculate the content of methyl hesperidin by the following formula.

$$\text{Content(\%)} = \frac{753.7A}{\text{weight of the sample(mg)}} \times 100$$

Methyl *p*-Hydroxybenzoate

Chemical Formula: C₈H₈O₃

Molecular Weight: 152.15

INS No.: 218

Synonyms: Methyl *p*-oxybenzoate; Methylparaben

CAS No.: 99-76-3

Compositional Specifications of Methyl *p*-Hydroxybenzoate

Content Methyl *p*-Hydroxybenzoate, when calculated on the dried basis, should contain not less than 99.0% methyl *p*-hydroxybenzoate (C₈H₈O₃).

Description Methyl *p*-Hydroxybenzoate is colorless crystal or white crystalline powder with slight or no scent

Identification To 0.5 g of Methyl *p*-Hydroxybenzoate, add 10 mL of sodium hydroxide, boil about 30 minutes, evaporate to about 5 mL, and cool. Acidify this solution with diluted sulfuric acid and wash formed precipitates with water. Dry it for 1 hour at 105°C, and the melting point is 213 ~ 217°C.

Purity (1) Melting Point : Melting point of Methyl *p*-Hydroxybenzoate should be within a range of 125~128°C.

(2) Free Acid : 15 mL of water is added to 0.75 g of Methyl *p*-Hydroxybenzoate and heated for 1 minutes in effervescent water bath and cooled. The filtrate is acidic or neutral. To 10 mL of filtrate, 0.2 mL of 0.1N sodium hydroxide and 2 drops of methyl red solution are added. A yellow color develops.

(3) Arsenic : It should be no more than 4.0 ppm tested by Arsenic Limit Test.

(4) Lead : When 5.0 g of Methyl *p*-Hydroxybenzoate is tested by Atomic Absorption Spectrophotometry or Inductively Coupled Plasma Emission Spectroscopy, its content should not be more than 2.0 ppm.

(5) *p*-Hydroxybenzoate and salicylic acid : 0.5g of Methyl *p*-Hydroxybenzoate is dissolved in 30mL of ether, and 20 mL of Sodium Bicarbonate(1→100) is added and mixed. Separate the water layer. The water layer is washed with 20 mL each of ether twice, and 5mL of diluted sulfuric acid and 30 mL of ether are added. Separate the ether layer and wash with 10 mL of water. Filter ether layer, wash the container of the solution and mix it in the solution. Evaporate the ether of the solution to dryness in a water bath. Dry the residue in sulfuric desiccator until the weight becomes constant. Then the content should be 5 mg or less. The constant residues are dissolved in water, heated to 70°C, and filtered. When diluted Ferric Chloride Solution is added to the solution, it should not be appeared red ~ dark red color.

Loss on Drying When Methyl *p*-Hydroxybenzoate dried for 5 hours in a desiccator (silica gel), the loss should not be more than 0.5%.

Residue on Ignition When thermogravimetric analysis is done with precisely weighed 2 g of Methyl *p*-Hydroxybenzoate, the amount of residue should not be more than 0.05%.

Assay 40 mL of 1 N sodium hydroxide solution is added to precisely weighed 2 g of Methyl *p*-Hydroxybenzoate, boiled for 30 minutes and cooled. Titrate the excess alkali with 1 N sulfuric acid (indicator : 5 drops of bromthymol blue solution). The color of end point is the color which appears by adding same indicator to buffer solution of pH 6.5. Separately, perform a blank test in the same manner.

1 mL of 1 N sodium hydroxide solution = 152.2 mg $C_8H_8O_3$

Methyl *N*-Methylantranilate



Chemical Formula: C₉H₁₁NO₂

Molecular Weight: 165.19

CAS No.: 85-91-6

Compositional Specifications of Methyl *N*-Methylantranilate

Content Methyl *N*-Methylantranilate should contain within a range of 98.0 ~ 101.3% of methyl *N*-methylantranilate (C₉H₁₁NO₂).

Description Methyl *N*-Methylantranilate occurs as colorless to light yellow, transparent crystalline lumps or liquid. It has a grape-like scent. The solution shows a bluish purple fluorescence.

Identification To 1 mL of Methyl *N*-Methylantranilate, add 5 mL of 10% alcoholic potassium hydroxide solution, equip with a reflux condenser, and heat for 1 hour. Its characteristic scent disappears. Cool, and acidify with diluted hydrochloric acid. Crystals are formed. Collect the crystals, and recrystallize from 50% ethanol. The melting point should be within a range of 164 ~ 174°C

Purity (1) Specific Gravity : Specific gravity of Methyl *N*-Methylantranilate should be within a range of 1.126 ~ 1.132.

(2) Refractive Index : Refractive Index n_D^{20} of Methyl *N*-Methylantranilate should be within a range of 1.578 ~ 1.581

(3) Solidification Temperature : Solidification temperature of Methyl *N*-Methylantranilate should not be less than 14°C.

(4) Clarity and Color of Solution : When 1 g of Methyl *N*-Methylantranilate is dissolved in 3 mL of 80% ethanol, the solution should be clear.

(5) Acid Value : Acid value of Methyl *N*-Methylantranilate is tested by Acid Value in Flavoring Substance Test. It should not be more than 1.

Assay

Approximately 1 g of Methyl *N*-Methylantranilate is precisely weighed and tested by Ester Value and Ester content in Flavoring Substances Test.

1 mL of 0.5 N alcoholic potassium hydroxide solution = 82.60 mg C₉H₁₁NO₂.

Methyl β -Naphthyl Ketone



Chemical Formula: $C_{12}H_{10}O$

Molecular Weight: 170.21

Synonyms: 2-Acetonaphthone

CAS No.: 93-08-3

Compositional Specifications of Methyl β -Naphthyl Ketone

Content Methyl β -Naphthyl Ketone should contain not less than 99.0% of Methyl β -Naphthyl Ketone ($C_{12}H_{10}O$).

Description Methyl β -Naphthyl Ketone occurs as white to light yellow crystals or crystalline powder, having a characteristic odor.

Identification (1) To 0.1 g of Methyl β -Naphthyl Ketone, add 3 g of zinc powder, mix well, and ignite directly on a burner while shaking. The mixture has odor of naphthalene.

(2) To 1 mL of solution of Methyl β -Naphthyl Ketone in ethanol (1 \rightarrow 100), add 2 drops of sodium nitroprusside solution, add 6 drops of sodium hydroxide solution, and shake. The color becomes red-purple, and add 3 drops of acetic acid. The color becomes blue.

Purity (1) Melting Point : Melting point of Methyl β -Naphthyl Ketone should not be less than 53°C.

(2) Clarity and Color of Solution : When 1 g of Methyl β -Naphthyl Ketone is dissolved in 5 mL of 95% ethanol by heating at 30°C, the solution should be clear.

(3) Chlorinated compounds : When Methyl β -Naphthyl Ketone is tested by Copper Mesh Test Method for Halogens in Test Methods for Flavorings, it should be appropriate.

(4) Arsenic : It should be no more than 4.0 ppm tested by Arsenic Limit Test.

(5) Lead : When 5.0 g of Methyl β -Naphthyl Ketone is tested by Atomic Absorption Spectrophotometry or Inductively Coupled Plasma Emission Spectroscopy, its content should not be more than 2.0 ppm.

Loss on Drying When Methyl β -Naphthyl Ketone is dried for 4 hours in a vacuum desiccator(silica gel), the weight loss should not be more than 0.5%.

Residue on Ignition When thermogravimetric analysis is done with Methyl β -Naphthyl Ketone, the residue should not be more than 0.05%.

Assay Accurately weigh about 1 g of Methyl β -Naphthyl Ketone, and proceed as directed under hydroxylamine Method 2 in Aldehyde and Ketone Content in Flavoring Substances Tests. In the procedure, boil the mixture for 1 hour before titrating.

1 mL of 0.5 N hydrochloric acid = 85.11 mg of $C_{12}H_{10}O$

Methyl Salicylate



Chemical Formula: $C_8H_8O_3$

Molecular Weight: 152.15

CAS No.: 119-36-8

Compositional Specifications of Methyl Salicylate

Content Methyl Salicylate should contain not less than 98.0% of methyl salicylate ($C_8H_8O_3$).

Description Methyl Salicylate is a colorless to light yellow liquid, and has a characteristic odor.

Identification 25 mL of 10% alcoholic solution of potassium hydroxide is added to 1 mL of Methyl Salicylate. When it is heated in a water bath with a reflux condenser, a characteristic scent disappears. It is heated again in a water bath and cooled, where 75 mL of water is added. The resulting solution responds to the test for salicylate salt (B) in Identification.

Purity (1) Specific Gravity : Specific gravity of Methyl Salicylate should be within a range of 1.180 ~ 1.185

(2) Refractive Index : Refractive index n_D^{20} of Methyl Salicylate should be within a range of 1.535 ~ 1.538

(3) Clarity and Color of Solution : When 1 mL of Methyl Salicylate is dissolved in 7 mL of 70% alcohol, the solution should be clear.

(4) Acid Value : Acid value of Methyl Salicylate is tested by Ester Value and Ester Contents in Flavoring Substance Test. It should not be more than 1. In this case, phenol red solution is used as an indicator.

Assay Accurately weigh about 0.9 g of Methyl Salicylate, and proceed as directed under Ester Content in Flavoring Substances Tests, using phenol red solution as the indicator.

1 mL of 0.05 N ethanolic potassium hydroxide = 76.08 mg of $C_8H_8O_3$

Methylethylcellulose

INS No.: 465

Synonyms: Ethyl methyl cellulose; Methyl ethyl ether of cellulose; MEC

CAS No. : 9004-69-7

Compositional Specifications of Methylethylcellulose

Content Methylethylcellulose, when calculated on the dried basis, should contain 3.5~6.5% methoxyl group ($-OCH_3$: 31.04) and 14.5~19.0% ethoxyl group ($-OCH_2CH_3$: 45.06)

Description Methylethylcellulose is scentless hygroscopic white ~ ivory white fibrous solid or powder.

Identification (1) When an aqueous solution (0.1→100) of Methylethylcellulose is shaken vigorously, a foamy layer is formed.

(2) When 5 mL of 5% copper sulfate solution or aluminum sulfate solution is added to 5 mL of aqueous solution (0.5→100), it should not form white precipitates.

Purity (1) Arsenic : It should be no more than 4.0 ppm tested by Arsenic Limit Test.

(2) Lead : When 5.0 g of Methylethylcellulose is tested by Atomic Absorption Spectrophotometry or Inductively Coupled Plasma Emission Spectroscopy, its content should not be more than 2.0 ppm.

(3) Cadmium : When 5.0 g of Methylethylcellulose is tested by Atomic Absorption Spectrophotometry or Inductively Coupled Plasma Emission Spectroscopy, its content should not be more than 1.0 ppm.

(4) Mercury : When Methylethylcellulose is tested by Mercury Limit Test, its content should not be more than 1.0 ppm.

Loss on Drying When Methylethylcellulose is dried at 105°C, weight loss should not be more than 15% for fibrous phase and 10% or less for powder phase.

Residue on Ignition Residue after ignition should not be more than 0.6%.

Assay Approximately 65 mg of Methylethylcellulose is precisely weighed into a bottle for decomposition (5 mL glass bottle with pressure stopper). 65 mg of adipic acid, 2.0 mL of internal standard solution, and 2.0 mL of hydroiodic acid (must be handled carefully) are added to the bottle, which is precisely weighed. The bottle is shaken for 30 seconds, heated for 20 minutes at 150°C, carefully shaken, and heated for 40 minutes again. After cooling for 45 minutes, the weight is precisely weighed. If the weight loss is less than 10 mg, the supernatant is used as Test Solution. Separately, 65 mg of adipic acid, 2.0 mL of internal standard solution, 2 mL of hydroiodic acid are added to a bottle for decomposition. After placing a stopper, it is weighed precisely. 15 μ L of ethyl iodide is added and weighed precisely. Using the same procedure, 45 μ L of methyl iodide is added and weighed. After shaking the bottle for 30 seconds, the supernatant is used as Standard Solution. 1 μ L of each solution is injected into a gas chromatography and the contents (%) of methoxyl group and hydroxypropoxyl group are obtained using the following equation.

$$\text{Content of methoxyl group (\%)} = \frac{Q_{Ta}}{Q_{Sa}} \times \frac{W_{Sa}}{\text{weight of the sample(mg)}} \times 21.86$$

$$\text{Content of ethoxyl group(\%)} = \frac{Q_{Tb}}{Q_{Sb}} \times \frac{W_{Sb}}{\text{weight of the sample(mg)}} \times 28.89$$

W_{Sa} : The amount of methyl iodide in Standard Solution (mg)

W_{Sb} : The amount of ethyl iodide in Standard Solution (mg)

Q_{Sa} , Q_{Sb} : Peak area ratios of methyl iodide and ethyl iodide vs. internal standard in Standard Solution

Q_{Ta} , Q_{Tb} : Peak area ratios of methyl iodide and ethyl iodide vs. internal standard in Test Solution

Operation Conditions

- Column : Diatomite for gas chromatography (Chromosorb WHP or its equivalent) coated with 10% methyl silicone oil or its equivalent
- Detector : Thermal Conductivity Detector (TCD) or (Hydrogen) Flame Ionization Detector (FID)
- Temperature at injection hole: 200°C
- Column Temperature : 50°C
- Detector Temperature : 200°C
- Carrier gas : Helium or Nitrogen
- Internal Standard Solution : 0.25 g of toluene is precisely weighed and dissolved in o-xylene (total volume 50 mL).

(6S)-5-Methyltetrahydrofolic Acid, Glucosamine Salt

Chemical Formula : $C_{32}H_{51}N_9O_{16}$

Molecular Weight : 817.80

Synonyms : 5-MTHF-glucosamine

CAS No.: 1181972-37-1

Compositional Specifications of (6S)-5-Methyltetrahydrofolic Acid, Glucosamine Salt

Content Glucosamine(converted to a dried form) should contain within a range of 34~46%, and (6S)-5-Methyltetrahydrofolic Acid(converted to a dried form) should contain within a range of 54~59%.

Description (6S)-5-Methyltetrahydrofolic Acid, glucosamine salt is light yellow~brown powder.

Identification (1) When (6S)-5-Methyltetrahydrofolic Acid, glucosamine salt is tested according to (1) potassium bromide disk method in Infrared Spectrophotometry, the same spectrum should be appear as a standard.

Purity (1) When the test solution is tested by Arsenic Limit Test, it should be no more than 2.6 ppm.

(2) Lead : When 5.0 g of (6S)-5-Methyltetrahydrofolic Acid, glucosamine salt is tested by Atomic Absorption Spectrophotometry or Inductively Coupled Plasma Emission Spectroscopy, its content should not be more than 2.0 ppm.

(3) Mercury : When (6S)-5-Methyltetrahydrofolic Acid, glucosamine salt is tested by Mercury Limit Test, its content should not be more than 0.1 ppm.

(4) Cadmium : When 5.0 g of (6S)-5-Methyltetrahydrofolic Acid, glucosamine salt is tested by Atomic Absorption Spectrophotometry or Inductively Coupled Plasma Emission Spectroscopy, its content should not be more than 1.0 ppm.

(5) Boron : 2 g of (6S)-5-Methyltetrahydrofolic Acid, glucosamine salt is transferred into a 500 mL flask for decomposition. 20 mL of water and 30 mL of nitric acid are added to the flask and mixed well, which is then heated gently. After cooling, 10 mL of sulfuric acid is added. By adding 2 ~ 3 mL of nitric acid at a time, the solution is heated until the liquid becomes colorless ~ pale yellow. This liquid is then cooled and 75 mL of water and 25 mL of saturated ammonium hydroxide solution are added. It is heated until white smoke appears. It is cooled and water is added so that the total volume is brought up to 50 mL (Test Solution). Separately, a blank test carried out following the same procedure to correct the Test Solution. The content of boron in boron standard solution, Test Solution, and blank test solution are obtained by ICP method in Test Method of Harmful Metals in General Test Methods in 「Food Codes」. The content of boron in Test Solution should not be more than 10 ppm (limited to cases where (6S)-5-Methyltetrahydrofolic Acid, glucosamine salt is reduced by sodium boron hydride).

(6) (6S)-5-Methyltetrahydrofolic Acid, glucosamine salt : 35 mg of (6S)-5-Methyltetrahydrofolic Acid, glucosamine salt is precisely weighed and add 90 mL of water and mix well. After ultrasonic extraction

for 1 minute at 20°C, add water to make 100 mL. Take 5 mL of this solution to the 10 mL flask and add mobile phase to titrate to 10 mL. And filtering by 0.45µm filtration and use it as test solution. Separately, Add 90 mL of water to 25 mg of (6R,S)-5-Methyltetrahydrofolic acid calcium salt and mix well. After ultrasonic extraction for 1 minute at 20°C, add water to make 100 mL. Take 5 mL of this solution to the 10 mL flask and add mobile phase to titrate to 10 mL. And filtering by 0.45µm filtration and use it as standard solution. Liquid chromatography is carried out with each test and standard solutions under the following operation conditions. The contents of (6S)-5-Methyltetrahydrofolic acid should be more than 99% by following calculating formula.

$$(6S)\text{-}5\text{-Methyltetrahydrofolic acid}(\%) = \frac{\text{Peak Area of (6S)-5-Methyltetrahydrofolic acid}}{\text{Sum of Peak Area of (6S)-5-Methyltetrahydrofolic acid and (6R)-5-Methyltetrahydrofolic acid}} \times 100$$

Operation Conditions

- Detector : UV absorption photometer (measured at wavelength 225 nm)
- Column : Chiral HSA(Chromtech, 4.0mm×100mm, 5µm) or equivalent
- Column Temperature : 30°C
- Mobile Phase : Adjust 100mL H_2PO_4 to pH 7.0 with 10% NaOH. Mix 940 mL of this solution and 60 mL of 2-propanol as a mobile phase.
- Flow Rate : 0.7 mL/min

(7) Total Viable Aerobic Count : When (6S)-5-Methyltetrahydrofolic Acid, glucosamine salt is tested by Microbe Test Methods for Total Viable Aerobic Count (Number of General Germs) in General Test Method in 「Standards and Specifications for Foods」, it should not be more than 100 per 1 g

(8) E. Coli : When (6S)-5-Methyltetrahydrofolic Acid, glucosamine salt is tested by Microbe Test Methods for *E. Coli* in General Test Method 「Standards and Specifications for Foods」, it should be negative (-).

Water Content Water content in (6S)-5-Methyltetrahydrofolic Acid, glucosamine salt is determined by water determination (Karl-Fisher Titration) and should not be more than 8.0%.

Assay (1) Glucosamine : 0.5 g of glucosamine is precisely weighed and dissolved in 50 mL of acetonitrile · water mixture (75:25), and put same solution to make the total volume of the solution 100 mL. This solution is filtered through a 0.45 µm filter (Test Solution). Separately, 0.5 g of D-glucosamine hydrochloride standard is precisely weighed and dissolved in 50 mL of acetonitrile-water mixture (75:25), and put same solution to make the total volume of the solution 100 mL. This solution is filtered through a 0.45 µm filter (Standard Solution). Each Standard Solution and Test Solution is injected into liquid chromatography using the following operation conditions. The content (%) of glucosamine is obtained from the following equation.

$$\text{Content of glucosamine (\%)} = \frac{A_t \times P_{\text{std}} \text{ T\%} \times 100}{A_{\text{std}} \times P_c \times (100 - m)}$$

A_c : Peak area of Test Solution

P_{std} : Weight of Standard (mg)

A_{std} : Peak area of Standard Solution

P_c : Weight of the sample (mg)

T% : Glucosamine ratio of reference material(%)

m : Water Content(%)

Operation Conditions

-Detector : UV 190 nm

-Column : Shodex Asahipak NH2P-50 4E(4.6mm × 250mm, 5μm) or its equivalent

-Column Temperature : 35 °C

-Mobile Phase : acetonitrile-water mixture (75:25)

-Flow Rate : 1.0 mL/min

(2) (6S)-5-Methyltetrahydrofolic acid : 70 mg of (6S)-5-Methyltetrahydrofolic Acid, glucosamine salt is precisely weighed and dissolved in water, and make the total volume of the solution 100 mL. This solution is filtered through a 0.45 μm filter (Test Solution). Separately, take the amount equivalent to 40 mg with (6S)-5-Methyltetrahydrofolic acid calcium as (6S)-5-Methyltetrahydrofolic acid and dissolve in water with 100mL flask and make the total volume of the solution 100mL(Standard Solution). Each Standard Solution and Test Solution is injected into liquid chromatography using the following operation conditions. The content (%) of (6S)-5-Methyltetrahydrofolic Acid, glucosamine salt is obtained from the following equation.

$$\text{Content of (6S)-5-Methyltetrahydrofolic acid (\%)} = \frac{A_t \times P_{\text{std}} \text{ T\%} \times 100}{A_{\text{std}} \times P_c \times (100 - m)}$$

A_c : Peak area of Test Solution

P_{std} : Weight of Standard(mg)

A_{std} : Peak area of Standard Solution

P_c : Weight of the sample (mg)

T% : (6S)-5-Methyltetrahydrofolic acid ratio of reference material(%)

m : Water Content(%)

Operation Conditions

-Detector : UV 280 nm

-Column : Gemini phenomenex(4.6mm×250mm, 5µm) or its equivalent

-Column Temperature : 25 °C

-Mobile Phase : A solution : Dissolve 6.8 g of KH_2PO_4 in 350 mL of water. Adjust it to pH 6.5 with 20% KOH, and make it to 1,000 mL with water.

B solution : Dissolve 4.08 g of KH_2PO_4 in 650 mL of water. Mix with 350 mL of Acetonitrile. Adjust to pH 8.0 with 20% KOH.

Time(min.)	A(%)	B(%)
0	100	0
15	60	40
17	30	70
22	30	70
31	100	0

-Flow Rate : 1.0 mL/min

Microfibrillated Cellulose

Definition Microfibrillated Cellulose is microfibrillated cellulose obtained by homogenizing fibers such as pulps.

Compositional Specifications of Microfibrillated Cellulose

Description Microfibrillated Cellulose is white and wet fiber.

Identification (1) When 30 g of Microfibrillated Cellulose (converted to a dried form) is dispersed in water (total weight = 300 g) and homogenized at 3,000~5,000 rpm for 5 minutes, it becomes a suspension without fluidity. Suspension is maintained in 3 hours without separation.

(2) 1 mL of phosphoric acid is added to 1 mg (converted to a dried form) of Microfibrillated Cellulose, which is heated for 30 minutes in a water bath. When 4 mL of catechol phosphate solution (1→500) is added to this solution and heated for 30 minutes, it becomes red.

(3) When 2 mL of iodine solution (1→5) is added to 0.05 g (converted to a dried form) and set aside for 5 minutes, the color of the solution is maintained. The supernatant is discarded by leaning. When 1 drop of diluted sulfuric acid (1→2) is added to the residue, the color becomes bluish violet.

Purity (1) Acidity : 2 g (converted to a dried form) of Microfibrillated Cellulose is dispersed in 100 mL of water (freshly boiled and cooled). pH of this suspension should be 5.0 ~ 8.0 (using glass electrode).

(2) Arsenic : It should be no more than 2.0 ppm tested by Arsenic Limit Test.

(3) Lead : When 5.0 g of Microfibrillated Cellulose is tested by Atomic Absorption Spectrophotometry or Inductively Coupled Plasma Emission Spectroscopy, its content should not be more than 2.0 ppm.

(4) Starch : The suspension in Purity (1) is filtered. When 2 ~ 3 drops of 0.1 N iodine solution is added to 20 mL of this filtrate, it is not appeared blue ~ bluish violet in color.

(5) Water Solubles : 100 mL of water is added to 10 g (converted to a dried form) of Microfibrillated Cellulose, which is heated (with a reflux condenser) for 30 minutes in an oil bath. Cool the solution. It is vacuum filtered through a glass filter(G4). 50 mL of the filtrate is evaporated to dryness. The residue is dried for 1 hour at 105°C. The amount of residue should not be more than 50 mg.

(6) Total Viable Aerobic Count : When Microfibrillated Cellulose is tested by Microbe Test Methods for Total Viable Aerobic Count (Number of General Germs) in General Test Method in 「Standards and Specifications for Foods」, it should not be more than 5,000 per 1 g

(7) E. Coli : When Microfibrillated Cellulose is tested by Microbe Test Methods for E. Coli in General Test Method 「Standards and Specifications for Foods」, it should be negative (-).

Loss on Drying When Microfibrillated Cellulose is dried for 3 hours at 100°C, the weight loss should not be more than 80%.

Residue on Ignition When Residue on Ignition is done with precisely weighted material, the amount of residue should not be more than 0.3%.

Milk Clotting Enzyme

RENNET

Chymosin

Definition Milk Clotting Enzyme is an enzyme obtained from the stomach of cow, sheep and etc., or from the cultures of *Kluyveromyces lactis*, *Rhizomucor miehei*, *Rhizomucor pusillus*, *Mucor sp.*, *Irpex lacteus*, *Bacillus cereus*, *Crypnohectria parasitica*, *Eshericha coli* and an enzyme obtained from *Aspergillus awamori* in which chymosin gene of calf is inserted. Dilutant or stabilizer can be added for the purpose of activity adjustment and quality preservation.

Compositional Specifications of Milk Clotting Enzyme

Description Milk Clotting Enzyme is white ~ dark brown powder, particle, paste or colorless ~ deep brown liquid.

Identification When Milk Clotting Enzyme is proceeded as directed under Activity Test, it should have the activity as Milk Clotting Enzyme.

Purity (1) Arsenic : It should be no more than 4.0 ppm tested by Arsenic Limit Test.

(2) Lead : When 5.0 g of Milk Clotting Enzyme is tested by Atomic Absorption Spectrophotometry or Inductively Coupled Plasma Emission Spectroscopy, its content should not be more than 5.0 ppm.

(3) Coliform Group : Milk Clotting Enzyme is tested by Microbe Test Methods for Coliform Group in General Test Methods in 「Standards and Specifications for Foods」. It should contain 30 colonies or less per 1 g of this product.

(4) Salmonella : Milk Clotting Enzyme is tested by Microbe Test Methods for Salmonella in General Test Methods in 「Standards and Specifications for Foods」. It should be negative (-).

(5) E. Coli : When Milk Clotting Enzyme is tested by Microbe Test Methods for E. Coli in General Test Method 「Standards and Specifications for Foods」, it should be negative (-).

Activity Test (Activity)

Analysis Principle : Activity test is based on clotting time of reaction mixture of rennet standard and enzyme using defatted dried milk at pH 6.5.

•Preparation of Test Solution : Test Solution is prepared using acetate buffer solution so that the clotting time falls within ± 40 seconds of mixed standard solution.

•Test Procedure : 25 mL each of substrate solution is placed in 2 flasks, which are set up in a rotational apparatus. The flasks are hung in a $32 \pm 0.2^\circ\text{C}$ water bath and tilted at an appropriate angle. While rotating, substrate solution is isothermalized for at least 12 minutes (maximum 20 minutes). 0.5 mL each of Test Solution and Standard Solution is added to each flask, which is then rotated and clotting time is measured. Clotting time is the time when fine particles are adsorbed on the inner wall of the flask. Activity is obtained by the following equation.

$$\text{IMCU/g or mL} = 1,000 \times \frac{T_s}{T} \times \frac{D_s}{D}$$

Tc Dc

1,000 : activity of milk clotting enzyme standard

Ts : clotting time of mixed standard solution (seconds)

Tc : clotting time of test solution

Ds : concentration of mixed standard solution (g/mL)

Dc : concentration of test solution (g/mL)

Agents and Solutions

- Calf rennet standard (1,000 IMCU, IDF standard) : Should contain not less than 98% of chymosin and not more than 2% of bovine pepsin.
- Adult bovine rennet standard (1,000 IMCU, IDF standard) : Should contain not more than 1% of chymosin and no less than 99% of bovine pepsin.
- Substrate Solution : 110 g of defatted milk, dried at low temperature, is placed in a 2,000 mL beaker, where 100 mL of 0.05% calcium chloride solution is added and homogenized. 900 mL of 0.05% calcium chloride solution is added and stirred for 30 minutes (care must be taken to prevent excessive foaming). The resultant solution is allowed to stand for 30 minutes in a dark place. When pH is measured, it should be approximately 6.5 (pH should not be adjusted). This solution should be used within 4 hours.
- Mixed Standard Solution : Mixed standard solution is prepared by obtaining a mixture ratio of calf rennet standard solution and adult bovine rennet standard solution, and mixing . Mixing ratio of calf rennet standard solution and adult bovine rennet standard solution is obtained by applying chymosin content(%) to Fig 1 in content of chymosin and pepsin in sample.
- Calf rennet Standard Solution : 2.5 g of calf rennet standard is precisely weighed and dissolved in 15 ~ 20 mL of acetate buffer solution in a 50 mL flask. The total volume is brought up to 50 mL with acetate buffer solution. 3 mL of this solution is further diluted to 50 mL with acetate buffer solution.
- Adult bovine rennet Standard Solution : It is prepared by the same method as calf rennet standard solution using adult bovine rennet standard.
- Acetate buffer solution (pH 5.5) : 10 mL of 1 M acetic acid and 10 g of sodium acetate (3 hydrate) 10 g are mixed and water is added to bring the total volume to 1,000 mL. pH of this solution should be 5.5 and is adjusted if necessary.

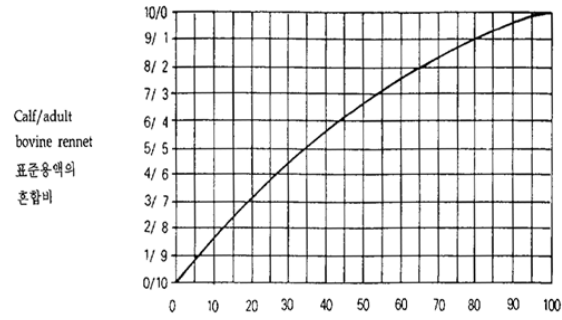

Fig. 1 Mixing ratio of calf rennet and adult bovine rennet standards against chymosin content (%) in the sample for mixed standard solution preparation

Storage Standard of Milk Clotting Enzyme

Milk Clotting Enzyme should be stored in a hermetic container in a cold dark place.

Milt Protein

Definition Milt Protein is obtained by the following procedure. Hexane and alkaline proteins in testicles of salmon (*Oncorhynchus keta* WALBAUM) of salmonidae or skipjack tuna (*Katsuwonus pelamis* LINNAEUS) of scombridae are decomposed by acid, which is then neutralized. Its component is alkaline protein (protamine, histone).

Compositional Specifications of Milt Protein

Content If Milt Protein is converted to a dehydrated form, it should contain no less than 50% protamine.

Description Milt Protein is white ~ pale yellow powder with characteristic taste.

Identification (1) 1 mg of Milt Protein is dissolved in 2 mL of water. 5 drops of a solution containing 0.1 g of α -naphthol solution in 100 mL diluted ethyl alcohol (7→10) and 5 drops of sodium hypochlorite solution (4~6%) are added to this solution. When this solution is alkalinized with sodium hydroxide solution, it becomes clear red.

(2) 5 mg of Milt Protein is dissolved in 1 mL of water by heating. When 1 drop of sodium hydroxide solution (1→10) and 2 drops of copper sulfate solution (1→7) are added, it becomes reddish violet.

Purity (1) Clarity of Solution : When 0.5 g of Milt Protein is mixed with 50 mL of water for 5 minutes, its color is colorless ~ pale yellow and its turbidity should be low or better.

(2) Arsenic : It should be no more than 4.0 ppm tested by Arsenic Limit Test.

(3) Lead : When 5.0 g of Milt Protein is tested by Atomic Absorption Spectrophotometry or Inductively Coupled Plasma Emission Spectroscopy, its content should not be more than 5.0 ppm.

Loss on Drying When Milt Protein is dried for 3 hours at 100°C, the weight loss should not be more than 7.0%.

Ash When Milt Protein tested by Ash and Acid-Insoluble Ash Limit, the amount of ash should not be more than 12%.

Assay Approximately 150 mg of Milt Protein is precisely weighted and tested by Kjeldahl Method in Nitrogen Determination. The content is calculated by the following equation.

$$1 \text{ mL of } 0.1 \text{ N sulfuric acid} = 1.401 \text{ mg N}$$

$$\text{Content(\%)} = \frac{\text{content of nitrogen(mg)} \times 3.19}{\text{Weight of the sample(g)} \times \frac{100 - \text{loss on drying(\%)}}{100}} \times 100$$

Modified Hop Extract

Definition Fruits of mulberry hop (*Humulus lupulus L.*) are ground and extracted with hexane or carbon dioxide. The extract is isomerized, reduced by adding hydrogen or sodium borohydride, and purified.

Compositional Specifications of Modified Hop Extract

Description Modified Hop Extract is yellow ~ yellowish green ~ yellowish brown liquid or paste. Or it is yellowish brown ~ reddish brown liquid containing reddish brown ~ dark brown paste with characteristic scent.

Identification Modified Hop Extract is dissolved in 0.012 N alkaline solution of methyl alcohol. The concentration is adjusted so that absorption at 253 nm is 0.6 ~ 0.9. Modified Hop Extract has the maximum absorption band near 253 nm and no absorption band at 325 ~ 330 nm.

◦ 0.012 N alkaline solution of methyl alcohol : 12 mL of 1 N sodium hydroxide solution is diluted to with methyl alcohol to 1 L.

Purity (1) Arsenic : It should be no more than 4.0 ppm tested by Arsenic Limit Test.

(2) Lead : When 5.0 g of Modified Hop Extract is tested by Atomic Absorption Spectrophotometry or Inductively Coupled Plasma Emission Spectroscopy, its content should not be more than 10 ppm.

(3) Boron : 2 g of Modified Hop Extract is transferred into a 500 mL flask for decomposition. 20 mL of water and 30 mL of nitric acid are added to the flask and mixed well, which is then heated gently. After cooling, 10 mL of sulfuric acid is added. By adding 2 ~ 3 mL of nitric acid at a time, the solution is heated until the liquid becomes colorless ~ pale yellow. This liquid is then cooled and 75 mL of water and 25 mL of saturated ammonium hydroxide solution are added. It is heated until white smoke appears. It is cooled and water is added so that the total volume is brought up to 50 mL (Test Solution). Separately, a blank test carried out following the same procedure to correct the Test Solution. The content of boron in boron standard solution, Test Solution, and blank test solution are obtained by ICP method in Test Method of Harmful Metals in General Test Methods in 「Food Codes」. The content of boron in Test Solution should not be more than 310 ppm (limited to cases where Modified Hop Extract is reduced by sodium boron hydride).

(4) Hexane : Modified Hop Extract is tested by Purity (5) for 「Paprika Extract Pigments」. The content of hexane should not be more than 25 ppm (limited to cases where hexane is used as extraction solvent).

Monascus Color

Definition Monascus Color is a pigment obtained by extracting the cultures of *Monascus anka* (*Monascus purpureus*) with ethyl alcohol. Its major component is Monascorvbirin and Ankaflavin and so on. Dilutant, stabilizer, or solvent can be added for the purpose of color value adjustment and quality preservation.

Compositional Specifications of Monascus Color

Content Color value ($E_{1cm}^{10\%}$) of Monascus Color should not be more than the indicated content.

Description Monascus Color is red ~ dark red liquid, solid, powder or paste with a slight characteristic scent.

Identification (1) 50 v/v% alcoholic solution of Monascus Color becomes red color and has a maximum absorption band near 500 nm.

(2) Add 2 mL of ammonia water and 1 mL of acetone to 1 mL of Test Solution obtained in Color Value section of Monascus Color. When the solution is heated for 1 minute in an approximately 50°C water bath, it becomes yellowish green.

(3) When 3 mL of nitric acid is added to 0.1 mL of Test Solution obtained in Color Value section, it becomes yellow and then changes to yellowish green.

Purity (1) Arsenic : It should be no more than 4.0 ppm tested by Arsenic Limit Test.

(2) Lead : When 5.0 g of Monascus Color is tested by Atomic Absorption Spectrophotometry or Inductively Coupled Plasma Emission Spectroscopy, its content should not be more than 10.0 ppm.

(3) Citrinin : Wash methanol. Pack resin of acrylesters or styrene-divinylbenznes to make 10cm of height in the glass column with 1cm of inside diameter. 1g of Monascus Color (converted to color value 50) is accurately taken and packed in the upper layer of glass column. Developing solvent of mixture solution of methanol - water(7:3) in the column is flowed with speed of 2 -3 mL/min. 20 mL of initial eluted solution is splitted. Check the absorbed resin to know whether citrinin is splitted in the 20 mL of initial eluted solution. Filter the solution with membrane filter of no more than 0.5 μm pore size. The solution is used for Test Solution. Separately, 10.0 mg of Citrinin is precisely weighted. Volume up with methanol to make 100 mL. Add 1 mL of this solution to mixture of methanol-water(7 : 3) to make 100 mL. 10.0 mL, 5.0 mL and 1.0 mL are taken in this solution. These solutions are volumed up to make 100 mL with mixture solution of methanol-water(7 : 3). 5 μl of Test Solution and Standard Solution are taken, respectively. When the solutions are conducted by Liquid Chromatography according to following operation, the level should not be more than 0.2 $\mu\text{g/g}$ (Color value is converted to 50). Calculate the area of Citrinin in each peak. Draw standard curve. The level of Citrinin should be applied according to Curve line which is calculated by the area of tailed peak in order that the area of Citrinin in the Test Solution influence on tailing of other peaks

Operation Condition

Detector and wave length : Fluorescence Detector

(Excitation Wave : 330nm,
Fluorescence Wave: 500nm)

Column : The column which is packed with octadecylsilylated silicagel
(ODS Column, 5 μ m, 4.6 mm \times 250mm or its equivalent)

Mobile phase: Acetonitril : water : Acetate tri-fluorine(TFA) Solution(100 : 100 : 1)

Flow rate : 1ml/min

Assay (Color Value) Appropriate amount of Monascus Color is precisely weighted to be measured the absorbance within a range of 0.3 ~ 0.7, and dissolve in 50 v/v% alcohol so that the total volume is 100 mL. Use the Test Solution. If necessary, the solution is centrifuged and the supernatant is used. Using 50 v/v% alcohol as a reference solution, absorption A is measured at the maximum absorption near 500 nm in 1cm path length. Color value is obtained using the following equation.

$$\text{Color Value (E}_{1\text{cm}}^{10\%}) = \frac{A \times 10}{\text{weight of the sample(g)}}$$

Monascus Yellow

Definition Monascus Yellow is a pigment obtained by drying, milling, and extracting the cultures of monascus (*Monascus pilosus* or *Monascus purpureus*) with acidic (hydrochloric acid) ethyl alcohol. Its major component is Xanthomonasins. Dilutant, stabilizer, or solvent can be added for the purpose of color value adjustment and quality preservation.

Compositional Specifications of Monascus Yellow

Content Color value ($E_{1cm}^{10\%}$) of Monascus Yellow should not be less than the indicated value.

Description Monascus Yellow is red ~ yellowish brown liquid, solid, powder or paste with a slight characteristic scent.

Identification (1) 50 v/v% alcoholic solution of Monascus Yellow shows yellow color and fluorescent-green, which has a maximum absorption band near 460 nm.

(2) When an aqueous solution (1→5) of Monascus Yellow is alkalinized with sodium hydroxide solution (1→25), its color changes to red ~ reddish brown.

(3) When 1 ~ 2 drops of sulfuric acid are added to an aqueous solution (1→5) of Monascus Yellow, yellow ~ yellowish brown precipitates are formed.

Purity (1) Arsenic : It should be no more than 4.0 ppm tested by Arsenic Limit Test.

(2) Lead : When 5.0 g of Monascus Yellow is tested by Atomic Absorption Spectrophotometry or Inductively Coupled Plasma Emission Spectroscopy, its content should not be more than 10.0 ppm.

Assay (Color Value) Appropriate amount of Monascus Yellow is precisely weighted to be measured the absorbance within a range of 0.3 ~ 0.7, and dissolve in 50 v/v% alcohol so that the total volume is 100 mL. Use the Test Solution. If necessary, the solution is centrifuged and the supernatant is used. Using 50 v/v% alcohol as a reference solution, absorption A is measured at the maximum absorption near 460 nm in 1cm path length. Color value is obtained using the following equation.

$$\text{Color Value } (E_{1cm}^{10\%}) = \frac{A \times 10}{\text{weight of the sample(g)}}$$

Monoammonium L-Glutamate

Monoammonium Glutamate

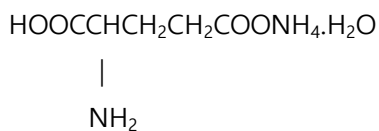

Chemical Formula: $\text{C}_5\text{H}_{12}\text{N}_2\text{O}_4 \cdot \text{H}_2\text{O}$

Molecular Weight: 182.18

INS No.: 624

Synonyms: Ammonium glutamate;
Monoammonium L-glutamate
monohydrate

CAS No.: 7558-63-6

[Content Specifications of Monoammonium L-Glutamate

Content Monoammonium L-Glutamate, when calculated on the dried basis, should contain not less than 99% of L-ammonium glutamate ($\text{C}_5\text{H}_{12}\text{N}_2\text{O}_4 \cdot \text{H}_2\text{O}$).

Description Monoammonium L-Glutamate occurs as colorless to white crystals or white crystalline powder. It is scentless.

Identification (1) To 1 mL Monoammonium L-Glutamate solution (1→30), add 1 mL of ninhydrine solution (0.2→100) and 0.1 g sodium acetate. Upon heating for 10 minutes in a water bath, this solution becomes deep bluish violet.

(2) To 10 mL of Monoammonium L-Glutamate solution (1→10) add 5.6 mL of 1 N hydrochloric acid, white crystalline precipitates of glutamic acid are formed. The precipitates are dissolved when 6 mL of 1 N hydrochloric acid is added and stirred.

(3) An aqueous solution (1→10) of Monoammonium L-Glutamate responds to the test for Ammonium Salts in Identification.

Purity (1) Specific Rotation : 10 g of Monoammonium L-Glutamate, precisely weighed, is dissolved in 2 N hydrochloric acid to make 100 mL. Optical rotation of this solution is measured. When it is converted into a dehydrated form, it should be within a range of $[\alpha]_D^{20} = +25.4 \sim +26.4^\circ$.

(2) Lead : When 5.0 g of Monoammonium L-Glutamate is tested by Atomic Absorption Spectrophotometry or Inductively Coupled Plasma Emission Spectroscopy, its content should not be more than 1.0 ppm.

(3) Pyrrolidone Carboxylic Acid : 1g of Monosodium L-Glutamate is weighed and dissolved in 100 mL of water, test solution. Separately, 1 g of pyrrolidone carboxylic acid is weighed and dissolved in water,

reference solution. Drop 1 μ l of test solution and reference solution on Thin Layer Plate prepared by using silica gel for thin-layer chromatography and develop about 10cm by using n-butanol: glacial acetic acid : water mixture (2:1:1) as developing solvent. Thin Layer Plate is dried at 80°C for 30 minutes . Spray color developing solution to it and heat it for at 80°C for 10 minutes. Pyrrolidone carboxylic acid spot in test solution should not be observed at the same position as reference solution. Color Developing solution : To 1g of Ninhydrin and 3mL of acetic acid, n-butanol is added to bring the total volume to 100 mL.

Loss on Drying When Monoammonium L-Glutamate is dried for 4 hours at 50°C, the weight loss should not be more than 0.5%.

Residue on Ignition When thermogravimetric analysis is done with 1 g of Monoammonium L-Glutamate, the amount of residue should not be more than 0.1%.

Assay Proceed as directed under Assay in 「L-Sodium Glutamate」.

1 mL of 0.1 N perchloric acid solution = 9.109 mg $C_5H_{12}N_2O_4 \cdot H_2O$

Monopotassium L-Glutamate

Monopotassium Glutamate

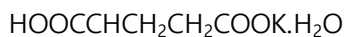

Chemical Formula: $\text{C}_5\text{H}_8\text{KNO}_4\cdot\text{H}_2\text{O}$

Molecular Weight: 203.24

INS No.: 622

Synonyms: Potassium glutamate

CAS No.: 19473-49-5

Compositional Specifications of Monopotassium L-Glutamate

Content Monopotassium L-Glutamate, when calculated on the dried basis, should not contain less than 99.0% of Monopotassium L-Glutamate ($\text{C}_5\text{H}_8\text{KNO}_4 \cdot \text{H}_2\text{O}$).

Description Monopotassium L-Glutamate occurs as colorless to white column-shaped crystals or white crystalline powder having a characteristic taste.

Identification (1) Proceed as directed under Identification (1) in 「L-Monoammonium Glutamate」.

(2) Proceed as directed under Identification (2) in 「L-Monoammonium Glutamate」.

(3) Monopotassium L-Glutamate solution (1→10) responds to the test for Potassium Salts in Identification

Purity (1) Specific Rotation : Approximately 10 g of Monopotassium L-Glutamate is dissolved in 2N hydrochloric acid to make 100 mL. Optical rotation of the solution is measured. When it is translated to dried material, it should be $[\alpha]_D^{20} = +22.5 \sim +24.0^\circ$.

(2) Lead : When 5.0 g of Monopotassium L-Glutamate is tested by Atomic Absorption Spectrophotometry or Inductively Coupled Plasma Emission Spectroscopy, its content should not be more than 1.0 ppm.

(3) pH : pH of Monopotassium L-Glutamate solution (1→50) should be within a range of 6.7 ~ 7.3.

(4) Chloride : When 0.07 g of Monopotassium L-Glutamate is tested by Chloride Limit Test, the amount should correspond to 0.4 mL of 0.01 N hydrochloric acid.

(5) Pyrrolidone Carboxylic Acid : 1g of Monopotassium L-Glutamate is weighed and dissolved in 100 mL of water, test solution. Separately, 1 g of pyrrolidone carboxylic acid is weighed and dissolved in water, reference solution. Drop 1 μl of test solution and reference solution on Thin Layer Plate prepared by using silica gel for thin-layer chromatography and develop about 10cm by using n-butanol: glacial acetic acid : water mixture (2:1:1) as developing solvent. Thin Layer Plate is dried at 80°C for 30 minutes . Spray color developing solution to it and heat it for at 80°C for 10 minutes. Pyrrolidone carboxylic acid spot in test solution should not be observed at the same position as reference solution.

Color Developing solution : To 1g of Ninhydrin and 3mL of acetic acid, n-butanol is added to bring the total volume to 100 mL.

Loss on Drying When Monopotassium L-Glutamate is dried for 5 hours at 80°C under reduced pressure, the weight loss should not be more than 0.2%.

Assay Proceed as directed under Assay in 「L-Sodium Glutamate」.

1 mL of 0.1 N perchloric acid = 10.16 mg of $C_5H_8NKO_4 \cdot H_2O$

Monosodium Fumarate

CH
CO
ON
a

II
HO
OC
CH

Chemical
Formula

:
 $C_4H_3O_4$
Na

Molecular
Weight:

138.06

Synony

INS
No.:
365

CAS
No.:
770
4-
73-6

Compositional Specifications of Fumarate

Content Monosodium Fumarate when calculated on the dried basis, should contain within a range of 98.0 ~ 102.0% of monosodium fumarate ($C_4H_3O_4Na$)

Description Monosodium Fumarate occurs as a white crystalline powder. It is odorless and has a characteristic acid taste.

Identification (1) Proceed as directed under Identification (2) and (3) in Fumaric Acid.

(2) Monosodium Fumarate responds to the test for Sodium Salt in Identification.

Purity (1) Clarity and Color of Solution : Weigh 0.5 g of Monosodium Fumarate, add 10 mL of water, and shake to dissolve while warming at 40°C for 10 minutes. It should be colorless and clear.

(2) pH : PH of Monosodium Fumarate solution (1→30) should be within a range of 3.0~4.0.

(3) Sulfate : Proceed as directed under Purity (2) in 「Fumaric Acid」.

(4) Arsenic : It should be no more than 4.0 ppm tested by Arsenic Limit Test.

(5) Lead : Monosodium Fumarate is tested by Purity (2) for 「Sodium Metaphosphate」 (not more than 2.0 ppm).

Loss on Drying When Monosodium Fumarate is dried for 4 hours at 120°C, the weight loss should not be more than 0.5%.

Residue on Ignition Monosodium Fumarate, previously dried, proceed as directed under thermogravimetric analysis, the residue should be within a range of 50.5 ~ 52.5%.

Assay Accurately weigh about 0.3 g of Monosodium Fumarate, previously dried, dissolve in 30 mL of water, and titrate with 0.1 N sodium hydroxide (indicators : 2 drops of phenolphthalein solution).

1 mL of 0.1 N sodium hydroxide = 13.81 mg of $C_4H_3O_4Na$

Monosodium L-Glutamate

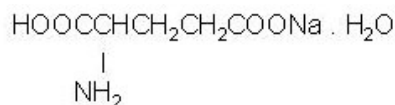

Chemical Formula: $\text{C}_5\text{H}_8\text{NNaO}_4 \cdot \text{H}_2\text{O}$

Molecular Weight: 187.13

INS No.: 621

Synonyms: Sodium glutamate

CAS No.: 6106-04-3

Compositional Specifications of Monosodium L-Glutamate

Content Monosodium L-Glutamate, when calculated on the dried basis, should contain not less than 99.0% of monosodium L-glutamate ($\text{C}_5\text{H}_8\text{NNaO}_4 \cdot \text{H}_2\text{O}$).

Description Monosodium L-Glutamate occurs as colorless ~ white prismatic crystallites or as white crystalline powder with a characteristic taste.

Identification (1) To 5 mL of Monosodium L-Glutamate solution (1→1,000), add 1 mL of ninhydrin solution (1→1,000), and heat for 3 minutes. A purple color develops.

(2) Monosodium L-Glutamate responds to the test for Sodium Salt in Identification

Purity (1) Clarity and Color of Solution : When 1 g of Monosodium L-Glutamate is dissolved in 10 mL of water, the solution should be colorless and clear.

(2) pH : pH of Monosodium L-Glutamate solution (1→10) should be within a range of 6.7 ~ 7.2.

(3) Specific Rotation : Dissolve about 10 g of Monosodium L-Glutamate, accurately weighed, in hydrochloric acid (1→4) and make to 100 mL. When optical rotation of Monosodium L-Glutamate is measured and converted to a value of a dried form, it should be $[\alpha]_D^{20} = +24.8 \sim +25.3^\circ$.

(4) Chloride : When 0.3 g of Monosodium L-Glutamate is tested by Chloride Limit Test, its content should not be more than the amount that corresponds to 0.35 mL of 0.01 N hydrochloric acid.

(5) Arsenic : It should be no more than 2.5 ppm tested by Arsenic Limit Test.

(6) Lead : When 5.0 g of Monosodium L-Glutamate is tested by Atomic Absorption Spectrophotometry or Inductively Coupled Plasma Emission Spectroscopy, its content should not be more than 1.0 ppm.

(7) Pyrrolidone Carboxylic Acid : Weigh 0.5 g of Monosodium L-Glutamate. Dissolve in 100 mL of water, and use it as a test solution. Separately, weigh 0.5 g of monosodium L-glutamate and 2.5 g of pyrrolidone carboxylic acid and dissolve in water, and use these as reference solutions. Drop 2 μL of the test solution and reference solutions on silica gel thin layer plate and develop about 10 cm by using n-butanol · glacial acetic acid · water mixture (2:1:1) as developing solvent. Dry thin layer plate at normal temperature for 30 minutes. Place a 50 mL beaker containing 3g of sodium hypochlorite in

the chamber, slowly add 1 mL of hydrochloric acid into the beaker to generate chlorine gas. Put on the lid and allow to stand for 30 sec to fill the chamber with chlorine. Place the dried plate in this chamber, put on the lid and allow to stand for 20 minutes. Take out the plate, keep for 10 minute in air and spray with ethanol. After drying, spray with potassium iodide-starch solution and observe the plate under natural light immediately after the standard spot has appeared. No spot corresponding to pyrrolidone carboxylic acid standard is detected is detected in the sample.

Potassium iodide-starch solution : Stir and heat 0.5 g of starch in about 50 mL of water until it gelatinizes. After cooling, add 0.5g of potassium iodide and water to make up to 100 mL.

Loss on Drying When Monosodium L-Glutamate is dried for 5 hours at 98°C, the weight loss should not be more than 0.5%.

Assay Dissolve about 0.15 g of Monosodium L-Glutamate, accurately weighed, in 3 mL of formic acid and add 50 mL of glacial acetic acid, and titrate with 0.1 N perchloric acid (indicator : 0.5 mL of α -naphthol benzene). The end point is where the solution changes its color from brown to green. Separately, a blank test is carried out by the same method.

1 mL of 0.1 N perchloric acid = 9.356 mg $C_5H_8NNaO_4 \cdot H_2O$

Morpholine Salts of Fatty Acids

Compositional Specifications of Morpholine Salts of Fatty Acids

Description Morpholine Salts of Fatty Acids occurs as a light yellow to yellow-brown waxy or oily substance.

Identification (1) To 10 g of Morpholine Salts of Fatty Acids, add 20 mL of hydrochloric acid (3→5), heat in a water bath for 10 minutes while shaking occasionally, and allow to cool. Remove separately oily or solid deposited portions. make the rest of the solution alkaline with sodium hydroxide solution. and perform the fractional distillation at 102 ~ 104°C. To 5 mL of the distillate, add 10 mL of picric acid saturated benzene, and shake. A yellow precipitate is formed. Recrystallize this precipitate, using benzene as the solvent. The melting point should be within a range of 144 ~ 147°C.

(2) To 1 g of Morpholine Salts of Fatty Acids, add 2 mL of ethanol, dissolve by heating, add 5 mL of diluted sulfuric acid, heat in a water bath for 30 minutes, and cool. Oil drops or white to yellow-white solids are precipitated. Separate the oil drops or solids, add 5 mL of ether, and shake. The oil drops or solids dissolve.

Purity (1) Arsenic : It should be no more than 4.0 ppm tested by Arsenic Limit Test.

(2) Lead : When 5.0 g of Morpholine Salts of Fatty Acids is tested by Atomic Absorption Spectrophotometry or Inductively Coupled Plasma Emission Spectroscopy, its content should not be more than 2.0 ppm.

Residue on Ignition When thermogravimetric analysis is done with Morpholine Salts of Fatty Acids, the residue should not be more than 1%.

Mucin

Definition Mucin is glycoprotein obtained by precipitating (with ethyl alcohol) the water soluble extracts from pig stomach.

Compositional Specifications of Mucin

Content Mucin (converted to a dried form) contains 73~90% of Mucin.

Description Mucin is grayish white or pale yellow powder.

Purity (1) Acidity : pH of aqueous solution (2→100) of Mucin should be 3.7~6.5 (measured with glass electrode).

(2) Arsenic : It should be no more than 4.0 ppm tested by Arsenic Limit Test.

(3) Lead : When 5.0 g of Mucin is tested by Atomic Absorption Spectrophotometry or Inductively Coupled Plasma Emission Spectroscopy, its content should not be more than 2.0 ppm.

(4) Nitrogen in Mucin : Extract with 70% alcohol based on Assay, and dry-mill the residue. The content should be 7 ~ 9% under Nitrogen Determination.

Total Nitrogen 250 mg of Mucin is precisely weighted and tested by nitrogen determination method. The content should not be less than 8.0%.

Ash 2 g of Mucin precisely weighted and tested by Ash and Acid-Insoluble Ash Limit, the amount of ash should not be more than 6.5%.

Loss on Drying When Mucin is dried for 5 hours at 105°C, the weight loss should not be more than 6%.

Assay 10 g of Mucin is precisely weighted into a 200 mL Erlenmeyer flask. It is extracted for 30 minutes with 100 mL of 70% alcohol and only the supernatant is decanted. This is repeated 5 times. All the extracts are mixed together and the total volume is brought up to 600 mL. It is then filtered. Transfer 50 mL of the filtrate into a beaker (previously weighted) and evaporated to dryness in a water bath. It is further dried for 5 hours at 105°C. The weight of the residue (S) is obtained and the content of mucin is calculated by the following equation.

$$\text{Content (\%)} = \frac{\text{Weight of sample (g)} - S \text{ (g)} \times 600/50}{\text{Weight of sample (g)}} \times 100$$

Myristic Acid

Tetradecanoic acid

Chemical Formula: $C_{14}H_{28}O_2$

Molecular Weight: 228.38

INS No.: 570

Synonyms: Tetradecanoic acid

CAS No.: 544-63-8

Definition Myristic Acid is a solid fatty acid obtained from coconut oil and other fats. Its major component is myristic acid ($C_{14}H_{28}O_2$).

Compositional Specifications of Myristic Acid

Description Myristic Acid is white ~ pale yellow crystalline solid or powder.

Purity (1) Acid Value : When 0.5 g of Myristic Acid is precisely weighted, and proceeded as directed under Acid value in Fats Test, the Acid value should be 242~249.

(2) Solidification point : Solidification point of Myristic Acid should be 48.0~55.5.

(3) Lead : When 5.0 g of Myristic Acid is tested by Atomic Absorption Spectrophotometry or Inductively Coupled Plasma Emission Spectroscopy, its content should not be more than 1.0 ppm.

(4) Arsenic : It should be no more than 4.0 ppm tested by Arsenic Limit Test.

(5) Mercury : When Myristic Acid is tested by Mercury Limit Test, its content should not be more than 1.0ppm.

(6) Iodine Value : Approximately 25 g of Myristic Acid is precisely weighted into a 500 mL Erlenmeyer flask with a stopper which contains 20 mL of 1 : 1 mixture of glacial acetic acid : cyclohexane and 25 mL of Weiss solution. A stopper is placed on the flask which is vigorously shaken and set aside for 1 hour in a dark place. 20 mL of potassium iodide solution and 100 mL of water(previously boiled and cooled) are added to the flask. The excess iodine is titrated with 0.1 N sodium thiosulfate solution. 0.1 N sodium thiosulfate solution is added drop wise until yellow color disappears. Starch solution is added and the titration is continued until the blue color disappears completely. Near the end point, the flask is vigorously shaken with a stopper. Separately, a blank test is carried out by the same procedure. Iodine value is obtained by the following equation and it should not be more than 1.0.

$$\text{Iodine Value} = \frac{(B-S) \times 1.269}{\text{weight of the sample(g)}}$$

B : Consumed amount of 0.1 N sodium thiosulfate solution in the blank test (mL)

S : Consumed amount of 0. 1N sodium thiosulfate solution in the test for sample (mL)

(7) Saponification Value : 3 g of Myristic Acid is precisely weighted into a 250 mL flask. After adding 50 mL of 0.5 N alcoholic solution of potassium hydroxide, a reflux condenser is attached and quietly

saponified for 30 minutes ~ 1 hour. This solution is used as test solution, tested under Saponification value in Fats Test, boiled (red color appears again) and titrated again until the red color disappears. Saponification value should be 242~251.

(8) Unsaponifiable matter : 5 g of Myristic Acid is precisely weighted into a 250 mL flask, where 2 g of potassium hydroxide and 40 mL of alcohol are added. After attaching a reflux condenser, gently refluxed for 1 hour. The solution transfer into a separatory funnel (3.5 cm diameter x 30 cm length with 40 mL, 80 mL, and 130 mL scale marks) with a stopcock. The flask is washed with sufficient amount of alcohol, which is added to the funnel (total volume= 40 mL). The flask is washed with warm and cold water, which is added to the funnel (total volume = 80 mL). Finally, the flask is washed with a few mL of petroleum ether, which is added to the funnel. Cool the solution, 50 mL of petroleum ether is added to the funnel. The funnel is shaken vigorously for 1 minute and then settled to separate two phases completely. The supernatant ether layer is collected in a 500 mL separatory funnel with a stopcock. The aqueous layer is again extracted 6 times with 50 mL each of ether. These extracts are added to the first extract. The combined extracts are washed with 25 mL of 10% alcohol. This procedure is repeated until the aqueous layer doesn't get colorized by phenolphthalein TS. When this is accomplished, aqueous phase is discarded and the ether extract transfer into a pre-weighted beaker. With 10 mL of ether, the funnel is washed, which is added to the beaker. Ether layer is evaporated to dryness in a water bath, which is then dried at 100°C for 30 minutes until the weight becomes constant. Then the residue is cooled in a desiccator and weighted. The residue dissolve in 50 mL of warm alcohol (neutralized with sodium hydroxide using phenolphthalein as an indicator). The resulting solution is titrated with 0.02 N sodium hydroxide solution until a pale red color persists. The amount of oleic acid is obtained by multiplying the consumed amount of sodium hydroxide solution with 5.659 (mg). The exact amount of unsaponifiables is obtained by subtracting the amount of fatty acid (as oleic acid) from the amount of residues. The content of unsaponifiable matter is calculated by the following equation and it should be 1%.

$$\text{Unsaponifiable matter(\%)} = \frac{\text{content of residue(mg)} - \text{content as oleic acid(mg)}}{\text{weight of the sample(g)}} \times \frac{100}{1,000}$$

Water Content Water content of Myristic Acid proceed as directed under water determination (Karl-Fisher Titration) and the content should not be more than 0.2%.

Residue on Ignition When Residue on Ignition analysis is done with accurately weighted 2 g of Myristic Acid, the amount of Residue on Ignition should not be more than 0.1%.

Naringin

Chemical Formula: $C_{28}H_{32}O_{14}$

Molecular Weight: 580.53

CAS No.: 10236-47-2

Definition Naringin is obtained by purifying the extracts of peels, juices, or seeds of tangerine (*Citrus paradisi* MACF.) of rutaceae with water, ethyl alcohol or methyl alcohol at room temperature. Its component is naringin

Compositional Specifications of Naringin

Content When Naringin is dried, it should contain 90 ~ 110% of the Naringin ($C_{28}H_{32}O_{14} = 580.53$).

Description Naringin occurs as colorless ~ pale yellow crystal with strong bitter taste.

Identification (1) 5 mg of Naringin dissolve in 10mL of 50% ethyl alcohol. When 1 ~ 2 drops of ferric chloride solution (1→500) are added to this solution, it becomes brown in color.

(2) When 5mg of Naringin dissolve in 5mL of Sodium hydroxide solution, the solution shows orange yellow ~ yellow color.

(3) A solution of 10 mg of Naringin in 500mL of water has a maximum absorption band in the wavelength range of 280 ~ 285nm.

Purity (1) Arsenic: It should be no more than 2.0 ppm tested by Arsenic Limit Test.

(2) Lead : When 5.0 g of Naringin is tested by Atomic Absorption Spectrophotometry or Inductively Coupled Plasma Emission Spectroscopy, its content should not be more than 5.0 ppm.

(3) Residual Solvents : When Naringin is tested by Purity (5) for Oleoresin Paprika, the content of methyl alcohol should not be more than 50 ppm.

Assay After drying for 3 hours at 105°C, approximately 0.2 g of Naringin is precisely weighted and dissolved in 50% ethyl alcohol (total volume = 100 mL). This solution is filtered through 0.45 μ m filter. 1 mL of this solution is diluted to 100 mL with water (Test Solution). Using water as a reference, the absorbance is measured at 280 nm and the content of Naringin is obtained from the following equation.

$$\text{Content of Naringin (\%)} = \frac{A}{28.0} \times \frac{10,000}{\text{weight of the sample(mg)}} \times 100$$

A: Absorbance of the test solution

Natamycin

Pimaricin

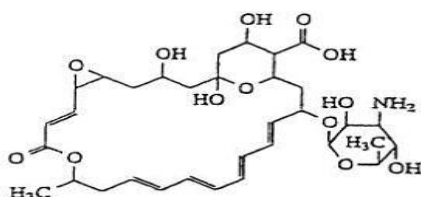

Chemical Formula: $C_{33}H_{47}NO_{13}$

Molecular Weight: 665.73

Synonyms: Pimaricin

INS No.: 235

CAS No.: 7681-93-8

Content The content should be more than 95.0% of Natamycin ($C_{33}H_{47}NO_{13}$, calculated on the anhydrous basis).

Description Natamycin is white to creamy white, crystalline powder.

Identification (1) On adding 1mg of Natamycin, on a spot plate, to 1mℓ of concentrated hydrochloric acid, a blue colour develops.

(2) A solution of 5mg of Natamycin in 0.1% glacial acetic acid in metanol has absorption maxima at about 290 nm, 303 nm and 318 nm.

Purity (1) Specific Rotation : 1 g of Natamycin(converted to a dehydrated form) dissolve in 100 mL of glacial acetic acid, measure the specific rotation, it should be $\alpha_{D20} = +250 \sim +295^\circ$.

(2) Acidity : pH of suspension (1→100) should be 5.0~7.5. (measured by glass electrode).

(3) Lead : When 5.0 g of Natamycin is tested by Atomic Absorption Spectrophotometry or Inductively Coupled Plasma Emission Spectroscopy, its content should not be more than 2.0 ppm.

(4) Arsenic : It should be no more than 4.0 ppm tested by Arsenic Limit Test.

(5) Mercury : When Natamycin is tested by Mercury Limit Test, its content should not be more than 1.0ppm.

(6) Total viable aerobic count : When Natamycin is tested by Microbiological Methods for Total viable aerobic count in General Test Method in 「Standards and Specifications for Foods」, it should not be more than 100 per 1 g

Water Content Water content of accurately weighted 0.03 g of Natamycin is determined by direct titration method in water determination (Karl-Fisher Method) and should not be more than 9.0%.

Residue on Ignition When Residue on Ignition analysis is done with accurately weighted 2 g of Natamycin, Residue on Ignition should not be more than 0.5%.

Assay Transfer about 0.02 g of Natamycin Reference and the sample, accurately weighted, to a 100-mL volumetric flask. Add 5.0 mL of tetrahydrofuran, and sonicate for 10 min. Add 60 mL of methanol, and swirl to dissolve. Add 25 mL of water, and mix. Allow to cool to room temperature. Dilute with water to volume, mix, and filter through a membrane filter of 5- μm or finer porosity. Separately inject about 20 μl for each of the "standard" and "the sample" into the chromatograph, and record the peak areas of the major peaks. Calculate the content of Natamycin following equation with obtained height or area of peak. Preparation is done with using a light resistant container to block out direct sunlight.

Content of

$$\text{Natamycin}(\text{C}_{33}\text{H}_{47}\text{NO}_{13}) (\%) = \frac{\text{Weight of Natamycin reference standard converted into an anhydride (g)}}{\text{Weight of the sample converted into an anhydride (g)}} \times \frac{\text{Peak area of the sample solution}}{\text{Peak area of reference standard solution}} \times 100$$

Operation Condition

Detector : UV 303nm

Column packing materials : 5 ~ 10 μm octadecylsilanized silica for liquid chromatography

Column : stainless steel tube 4~6 mm \times 25 cm

Column temperature : room temperature

Mobile Phase : Dissolve 3.0 g of ammonium acetate and 1.0 g of ammonium chloride in 760 mL of water, and mix, and filter through a 0.5- μm or finer porosity filter.

Flow rate : 2mL/min

Storage Standard of Natamycin

Natamycin should be stored in a light resistant container in a cold place.

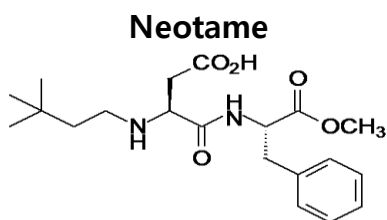

Chemical Formula: C₂₀H₃₀N₂O₅

Molecular Weight: 378.47

INS No.: 961

Synonyms: Methyl *N*-(3,3-dimethylbutyl)-L- α -aspartyl-L-phenylalanine

CAS No.: 165450-17-9

Compositional Specifications of Neotame

Content Neotame should contain 97.0-102.0% of Neotame(C₂₀H₃₀N₂O₅) on the anhydrous basis.

Description Neotame occurs as white to off-white powder.

Identification (1) Neotame is sparingly soluble in water, very soluble in ethanol.

(2) The infrared absorption spectrum of neotame is obtained using Infrared Spectrophotometry (1) Potassium Bromide Disk Method. The spectrum should correspond to the standard infrared spectrum as below.

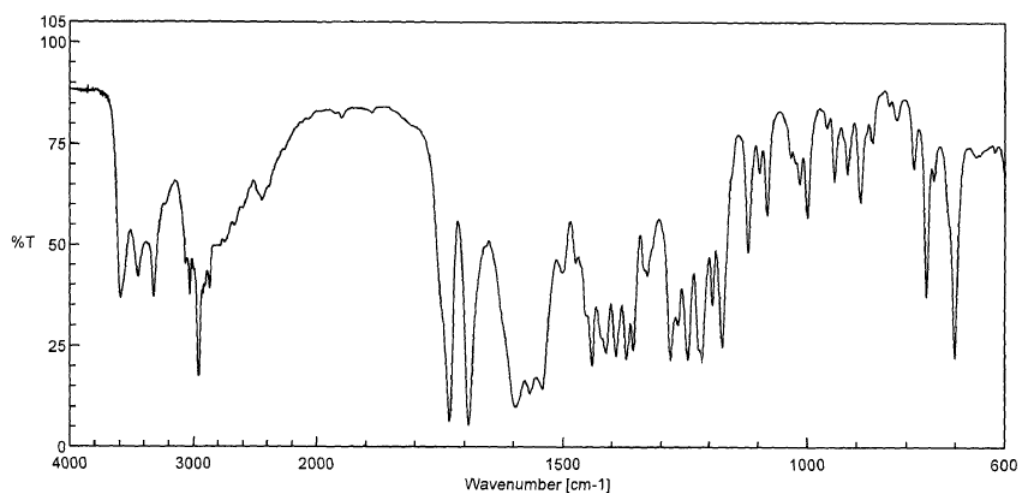

Purity (1) pH : The pH of a solution of neotame (1→200) should be within a range of 5.0 ~ 7.0 when measured with glass electrode.

(2) Melting range : The melting range of neotame should be within a range of 81 ~ 84°C.

(3) Optical specific rotation : Weight 0.25g of neotame and add water and dissolve it to make 50mL. Optical rotation of this solution is measured and it should be $[\alpha]_D^{25} = -40.0 \sim -43.3^\circ$ calculated on the anhydrous basis.

(4) Lead : When 5.0 g of neotame is tested by Atomic Absorption Spectrophotometry or Inductively

Coupled Plasma Emission Spectroscopy, its content should not be more than 1.0 ppm.

(5) Arsenic : It should be no more than 4.0 ppm tested by Arsenic Limit Test.

(6) N-[N-(3,3-Dimethylbutyl)- α -aspartyl]-L-phenylalanine : Use the test solution in Assay as the test solution. Accurately weight 0.03g of N-[N-(3,3-Dimethylbutyl)- α -aspartyl]-L-phenylalanine(measure content of water in advance), dissolve it in mobile phase solution to make 50mL. Take 10mL of this solution and dissolve it in mobile phase to make 100mL(Standard stock solution). Take 2, 10, 25, 50mL of the standard stock solution and add respectively mobile phase solution to make 100mL(Standard solution). Separately, Analyze 25 μ l portions of the test solution, standard solution, and standard stock solution by liquid chromatography using the operating conditions(The retention time of N-[N-(3,3-Dimethylbutyl)- α -aspartyl]-L-phenylalanine is about 4 minutes). Calculate the content by the formula. The content should be not more than 1.5% :

$$\text{Content of N-[N-(3,3-Dimethylbutyl)-}\alpha\text{-aspartyl] -L-phenylalanine(\%)} = \frac{W}{\text{Weight of the sample on the anhydrous basis(g)}} \times 100$$

W: Content of N-[N-(3,3-Dimethylbutyl)- α -aspartyl]-L-phenylalanine in test solution calculated from calibration curve(g)

(7) Other related substances : Analyze the test solution in Assay by liquid chromatography using the operating conditions(Analytical time is 1.5 times higher than the retention time of neotame). Calculate the content by the formula. The content of other related substances should be 2.0%:

$$\text{Content of other related substances(\%)} = \frac{A}{A+B} \times 100$$

A: The sum of the peak areas of other than the test solution of neotame, N-[N-(3,3-Dimethylbutyl)- α -aspartyl]-L-phenylalanine and solvent

B: The sum of the peak areas of the test solution of neotame and N-[N-(3,3-Dimethylbutyl)- α -aspartyl]-L-phenylalanine

Water content Accurately weight about 0.25g of neotame and analyze it by direct titration of Water Determination(Karl Fischer Method). The content should be not more than 5.0%.

Loss on Ignition Precisely weight 0.2g of neotame and dissolve it in mobile phase solution to make 100mL(the test solution). Separately, weight accurately about 0.1g of neotame standard(measure content of water in advance), dissolve it in mobile phase solution to make 100mL(Standard solution). Analyze

the test solution and standard solution by liquid chromatography using the operating conditions. Calculate the content by the formula:

$$\text{Content of Neotame(\%)} = \frac{\text{Weight of the neotame standard on the anhydrous basis(g)}}{\text{Weight of the sample on the anhydrous basis(g)}} \times \frac{A_T}{A_S} \times 100$$

A_T : Peak area of neotame in the test solution

A_S : Peak area of neotame in the standard solution

Operation Conditions

- Detector : Visible Absorption Detector (wave length 210 nm)
- Column : C18(4.6mm×100mm, 3~5 μ L) or its equivalent
- Column Temperature : 45°C
- Injection: 25 μ L
- Mobile Phase : Dissolve 3.0 of sodium 1-heptanesulfonate in 740mL of water and add 3.8mL of triethylamine. Adjust the resulting solution with phosphoric acid to a pH of 3.5, and dilute with water to 750mL. Add 250mL of acetonitrile, adjust with phosphoric acid to an apparent pH of 3.7.
- Flow Rate : 1.5 mL/min(adjust the flow rate so that the retention time of neotame is about 12 minutes after injection)

Nickel

Chemical Formula: Ni

Molecular Weight: 58.69

Synonyms: Nickel catalysts

CAS No.: 7440-02-0

Definition As Nickel catalysts, it is obtained by activation with hydrogen and heat treatment. However, silica, processed fats and oils and etc. are able to be added for the quality preservation and etc.

Compositional Specifications of Nickel

Content It should contain 10.0 ~ 30.0% of Nickel(Ni).

Description Nickel occurs as a dark gray powder, flake, or small drop shape.

Identification Add a few drops of boromine solution to 5 mL of a test solution which is obtained by the assay method of this additive, and add ammonium hydroxide to make it weakly alkaline. Then as adding 2~3 mL of dimethyl glycol solution, the color of the test solution indicates a deep red color and forms sediments.

Assay Weigh 2 g of this additive precisely and put it into 100 mL porcelain crucible which is half-filled with a quantitative filter paper pulp. Heat it slowly to 650°C so that the fats and oils on the surface to easily absorbed by the filter paper pulp. Then burn it gradually and heat it for 2 hours at 650°C then incinerate. After cooling down, add 20 mL of hydrochloric acid. After moving it to the 400 mL beaker, evaporate to dryness in bath. After cooling down again, add 20 mL of hydrochloric acid and warm it to dissolve well. After moving it to 500 mL massflask, calibrate and mix it. stay it for a while until insoluble matters settle down. Take 50 mL of upper side solution and add water to make 250 mL (If there is residue in the beaker, filter with the medium-speed filter paper). After adding 2 g of tritaric acid, heat it at 80°C and add 30 mL of dimethyl glyoxime solution. Add ammonium hydroxide until the test solution become weakly alkaline, and stay it for a 20 minutes in the bath. Filter the sediment by the glass filter, wash it with hot water until the cleaning fluid of the sediment show no chloride reaction. Dry the sediment at 120°C for 2 hours and then measure its weight by drying it in the desiccator until it reaches the mass, and calculate the percentage of nickel content according to the following formula.

$$\text{Nickel content(\%)} = \frac{10 \times (\text{amount of sediment(g)} \times 20.32)}{\text{Amount of samples taken(g)}}$$

20.32 : % of Nickel in sediment

Storage Standards of Nickel

Store in a sealed container in a dry and cool place.

Nicotinamide

Niacinamide



Chemical Formula: $C_6H_6N_2O$

Molecular Weight: 122.13

Synonyms: Niacinamide

CAS No.: 98-92-0

Compositional Specifications of Nicotinamide

Content Nicotinamide, when calculated on the dried basis, should contain within a range of 98.5 ~ 101.0% of nicotinamide ($C_6H_6N_2O$).

Description Nicotinamide occurs as a white crystalline powder. it is odorless and has a bitter taste.

Identification (1) A solution of Nicotinamide (1→10) is neutral.

(2) When 10 mg of Nicotinamide is burned on a platinum plate, an odor of pyridine is generated.

(3) When add 5 mL of sodium hydroxide solution to 20 mL of Nicotinamide and gently boil, an odor of ammonia is evolved.

Purity (1) Melting Point : Melting point of Nicotinamide should be within a range of 128 ~ 131°C.

(2) pH : Weight 1 g of Nicotinamide, dissolved in 20 mL water. pH of this solution should be within a range of 6.0 ~ 7.5.

(3) Lead : When 5.0 g of Nicotinamide is tested by Atomic Absorption Spectrophotometry or Inductively Coupled Plasma Emission Spectroscopy, its content should not be more than 2.0 ppm.

(4) Readily Carbonizable Substances : 0.2 g of Nicotinamide is tested by Readily Carbonized Substances. The color of the solution should not be deeper than that of a color standard A.

Loss on Drying When Nicotinamide is dried for 4 hours in a vacuum desiccator (silica gel), the content of loss should not be more than 0.5%.

Residue on Ignition When thermogravimetric analysis is done with Nicotinamide, the amount of residue should not be more than 0.1%.

Assay Accurately weigh about 0.2 g of Nicotinamide, and dissolve in 30 mL of glacial acetic acid (for non-aqueous titration) by heating, if necessary. After cooling, add 100 mL of benzene, which is titrated with 0.1 N perchloric acid (indicator : 2 drops of crystal violet-acetic acid solution). The end point is where the violet color of the solution changes to blue and then green. Separately, a blank test is carried out by the same procedure.

1 mL of 0.1 N perchloric acid = 12.21 mg of $C_6H_6N_2O$

Nicotinic Acid

Niacin



Chemical Formula: $C_6H_5O_2N$

Molecular Weight: 123.11

Synonyms: Niacin

CAS No.: 59-67-6

Compositional Specifications of Nicotinic Acid

Content Nicotinic Acid, when calculated on the dried basis, should contain within a range of 99.5 ~ 101.0% of nicotinic acid ($C_6H_5O_2N$).

Description Nicotinic Acid occurs as white crystals or crystalline powder. It is odorless and has a slightly acid taste.

Identification (1) 10 mg of mixture of Nicotinic Acid:2,4-dinitrochlorobenzene(1:2) transfer into a test tube, heat to melt the content for a few seconds, and cool. When 3 mL of alcoholic potassium hydroxide is added, it turns red ~ reddish purple

(2) 50 mg of Nicotinic Acid is dissolved in 20 mL of water, which is neutralized with 0.1 N sodium hydroxide solution. When 3 mL of cupric sulfate solution is added, a blue precipitate is gradually formed.

Purity (1) Melting Point : Melting point of Nicotinic Acid should be within a range of 234 ~ 238°C.

(2) Chloride : When 0.5 g of Nicotinic Acid is tested by Chloride Limit Test, its content should not be more than the amount that corresponds to 0.3 mL of 0.01 N hydrochloric acid.

(3) Sulfate : When 0.5 g of Nicotinic Acid is tested by Sulfate Limit Test, its content should not be more than the amount that corresponds to 0.2 mL of 0.01 N sulfuric acid.

(4) Lead : When 5.0 g of Nicotinic Acid is tested by Atomic Absorption Spectrophotometry or Inductively Coupled Plasma Emission Spectroscopy, its content should not be more than 2.0 ppm.

Loss on Drying When Nicotinic Acid is dried for 1 hour at 105°C, the weight loss should not be more than 1%.

Residue on Ignition When thermogravimetric analysis is done, the amount of residue should not be more than 0.1%.

Assay Accurately weigh about 0.3 g of Nicotinic Acid, dissolve in 50 mL of water, and titrate with 0.1 N sodium hydroxide (indicator : 5 drops of phenolphthalein solution).

1 mL of 0.1 N sodium hydroxide = 12.31 mg of $C_6H_5O_2N$

Nisin

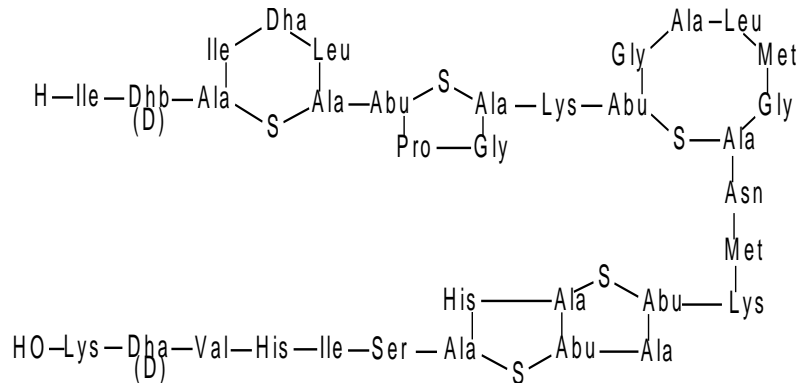

Abu = alpha-aminobutylic acid

Dha = dehydroalanine

Dhb = dehydrobutyrine

Molecular Weight 3354.12

Chemical Formula: $C_{143}H_{230}N_{42}O_{37}S_7$

Molecular Weight: 3354.12

INS No.: 234

Synonyms: Nisin preparation

CAS No.: 1414-45-5

Definition Nisin is a mixture of polypeptide produced by *Lactococcus lactis* (*Streptococcus lactis*), Lancefield group N and sodium chloride.

Compositional Specifications of Nisin

Content Nisin contains no less than 900 IU/mg of nisin ($C_{143}H_{230}N_{42}O_{37}S_7$).

Description Nisin occurs as a white, micronized powder.

Identification (1) Stability to acid : Suspend 100mg of Nisin in 0.02N hydrochloric acid as described in the preparation of the Nisin standard solutions under the Assay. After boiling this solution for 5 min, determine the Nisin concentration using test method under the Assay. No significant loss of activity is noted following this heat treatment. The Nisin concentration of the boiled Nisin is $100 \pm 5\%$. After adjusting the pH of the Nisin solution to 11 by adding 5N sodium hydroxide, heat the solution at 65°C for 30 min, and then cool. After adjusting the pH to 2.0 by adding hydrochloric acid, determine the Nisin concentration using Assay. Confirm complete loss of antimicrobial activity of Nisin following this treatment.

(2) Tolerance of *Lactococcus lactis* to high concentrations of Nisin: Prepare cultures of *Lactococcus lactis* (ATCC 11454, NCIMB 8586) in sterile skim milk by incubating for 18 hr at 30°C . Prepare one or more flasks containing 100 mL of litmus milk, and sterilize at 121°C for 15 min. Suspend 0.1 g of sample in the sterilized litmus milk, and allow to stand at room temperature for 2 hr. Add 0.1 mL of the *L. lactis*

culture, and incubate at 30°C for 24 hr. *L. lactis* will grow in this concentration of sample (about 1000 IU/mL).

- Purity**
- (1) Lead : When 5.0 g of Nisin is tested by Atomic Absorption Spectrophotometry or Inductively Coupled Plasma Emission Spectroscopy, its content should not be more than 1.0 ppm.
 - (2) Arsenic : It should be no more than 1.3 ppm tested by Arsenic Limit Test.
 - (3) Mercury : When Nisin is tested by Mercury Limit Test, its content should not be more than 1.0 ppm.
 - (4) Total viable aerobic count : When Nisin is tested by Microbiological Methods for Total viable aerobic count in General Testing Methods in 「Standards and Specifications for Foods」, it should not be more than 10 CFU/g.
 - (5) *E. coli*: When Nisin is tested by Microbiological Methods for *E. coli* in General Testing Methods in 「Standards and Specifications for Foods」, it should be negative in 25 g.
 - (6) *Salmonella* : When Nisin is tested by Microbiological Methods for *Salmonella* in General Testing Methods in 「Standards and Specifications for Foods」, it should be negative in 25 g.
 - (7) Coliform Group : Taurine is tested by Microbiological Methods for Coliform Group in General Testing Methods in 「Standards and Specifications for Foods」. It should be contain not more than 30 per 1 g of this product.

Sodium Chloride Approximately 20mg of Nisin, precisely weighted, dissolve in 50 mL of water contained in a glass-stoppered flask. Add, while agitating, 3 mL of nitric acid, 5 mL of nitrobenzene, 50 mL of 0.1N silver nitrate, and 2 mL of ferric ammonium sulfate. Shake well, and titrate the excess silver nitrate with 0.2N ammonium thiocyanate. The titration endpoint is indicated by the appearance of a red color. Perform a blank test using water, and calculate the content of sodium chloride in the sample by the formula. The content of sodium chloride should not be less than 50.0%.

$$\text{The content of sodium chloride (\%)} = (2 \times 5.844)(A-B)/S \times 100$$

A : The volume of 0.2N ammonium thiocyanate consumed by the blank test(mL)

B : The volume of 0.2N ammonium thiocyanate consumed by the sample test (mL)

S : Weight of sample (mg)

Assay

Medium : Dissolve 10 g of Bacteriological Peptone, 3 g of Beef Extract, 3 g of Sodium Chloride, 1.5 g of Autolyzed Yeast (Yeast Extract), 1 g of Brown Sugar, and 15 g of Agar in distilled water to a final volume of 1000 mL. Sterilize in an autoclave at 121°C for 15 min. The medium can be stored in a covered container at room temperature until use. At the time of use, melt the medium, and cool to approximately 50°C. Add 2% of a 1:1 mixture of Tween 20 (polyoxyethylene sorbitan monolaurate) and distilled water, previously held for 20~30 min at 48°C.

Assay Organism: Maintain *Micrococcus luteus* (ATCC 10240, NCIMB 8166) by subculturing on agar slants

of the medium and incubating at 30°C for 48 hours. Prepared slants may be stored for a maximum of 14 days at 4°C until required. When required for use, the growth on the slant cultures is suspended in 7 mL of sterilized normal saline solution.

Nisin Standard Stock Solution: Suspend 100 mg of Nisin Standard (1,000 IU/mg), precisely weighted, in 80 mL of 0.02N hydrochloric acid. Set aside at room temperature for 2 hr. Dilute the suspension to a final volume of 100 mL with 0.02N hydrochloric acid (1,000 IU/mL). The standard stock solution can be stored for up to 7 days at 4°C.

Nisin Standard Solution: Weigh 0.5, 1.0, 2.5, 5.0 and 10.0 mL of Standard Stock Solution accurately into separate 1000 mL volumetric flasks. Dilute each flask to volume with 0.02N hydrochloric acid to make 1000 mL. (0.5, 1.0, 2.5, 5.0, 10.0 IU/mL). Each standard solution is prepared freshly on the day of use.

Preparation of the Standard Curve: Dilute the suspension of the assay organism to 1:10 using normal saline solution, and then mix thoroughly. Add 2 mL of this solution to each 100 mL of melted medium held at 48°C. Pour the inoculated medium to a depth of 3~4 mm (approximately 15 mL) into five Petri dishes, and allow to solidify. Invert the plates, and store at 4°C for 1 hr. Bore four 8~9 mm (in diameter) holes on 30 mm centers in each plate of the agar medium. Besides, absorbing disc can be used. Transfer 0.2 mL each of Nisin standard solutions of 0.5, 1.0, 2.5, 5.0, and 10.0 IU/mL into the holes, one concentration to a plate. Cover the plates, and incubate them overnight at 30°C. Measure the zones of inhibition to the nearest 0.1 mm by means of calipers or other appropriate devices. Plot the Nisin concentration against the zone diameters, and draw the best straight line through the plotted points.

Procedure: Suspend 100 mg of sample in 80 mL of 0.02N hydrochloric acid in a 100 mL volumetric flask, and set aside at room temperature for 2 hr. Dilute the solution to volume by adding 0.02N hydrochloric acid. Dilute to a 1:200 solution with 0.02N hydrochloric acid. Proceed as described above for the standard curve, transferring in quadruplicate a measured volume of this solution(0.2mL) into the holes of four agar discs. Cover the plates, and incubate them overnight at 30°C. After incubation, measure the zones of inhibition. From the standard curve, determine the Nisin concentrations, and average the results.

Loss on Drying When 2 g of Nisin is dried for 2 hr at 105°C, the weight loss should not be more than 3.0%.

Storage Standards of Nisin

Nisin should be stored in well-closed containers at temperatures not exceeding 22°C

Nitrogen

Chemical Formula: N₂

INS No.: 941

Molecular Weight: 28.00

CAS No.: 7727-37-9

Composition Specifications of Nitrogen

Content Nitrogen should not contain less than 99.0% of nitrogen.

Description Nitrogen is a colorless, odorless gas or liquid.

Identification The flame of burning wood splinter is extinguished in an atmosphere of nitrogen.

Purity (1) Oxygen : The oxygen detector whose scale is in the range of 0 ~ 100 μ/L and which is attached with electrochemical cell is used. The oxygen in a sample generates electronic signals in the detector, proportional to the oxygen content. With an appropriate pressure adjustor, a metal pipe that does not pass air through, and a prescribed flow speed, the detector is controlled according to the instruction of the manufacturer to pass the gas through until a fixed value is measured. When nitrogen passes the cell containing potassium hydroxide, the content of oxygen should not be more than 1%(v/v).

(2) Carbon Monoxide : Both ends of the carbon monoxide detection pipe, and one end is connected to the container of Nitrogen and the other end to an appropriate flow meter. When about 1050 ± 50 mL of Nitrogen is passed through the detection pipe in a proper flow speed, the amount should not be more than 10 μl/L.

Assay Gas chromatography is performed with the following operating conditions. The amount of the control gas (a) injected and the operation conditions are controlled so that the height of the nitrogen peak in the chromatogram obtained by injecting the control gas is 35% of the recorder of full scale. Also, the oxygen and nitrogen peaks should be distinctively separated in the chromatogram. The peak area obtained in the chromatogram of the sample gas should not be less than 99.0% of the peak area of the control gas (b), by injecting the control gas (b) and the sample gas that is to be tested.

Operation Condition

-Column : Stainless Steel 2 mm × 2 m

-Packing material : Adsorption materials that can distinguish molecules of diameters 0.5 μm or less or those whose separation power is equivalent to them

-Carrier Gas : Helium 99.995% (v/v)

-Flow Speed : 40 mL/min

-Detector : Thermal Conductivity Detector

-Injector : Loop injector

-Column Temperature : 50°C

-Detector Temperature : 130°C

-Control Gas (a) : air

-Control Gas (b) : Nitrogen N₂ 99.999% (v/v) or more, CO 1ppm or less, O₂ 5ppm or less

Nitrous Oxide

Nitrogen Oxide
Dinitrogen Monoxide

Chemical Formula: N₂O

Molecular Weight: 44.01

INS No.: 942

Synonyms: Nitrogen oxide; Dinitrogen monoxide

CAS No.: 10024-97-2

Compositional Specifications of Nitrous Oxide

Content Nitrous Oxide should be contain not less than 97.0% of Nitrous Oxide.

Description Nitrous Oxide is colorless, tasteless, and scentless gas.

Identification Upon contact with extinguished piece of wood, it creates a violent flame.

Purity Weigh of sample should be converted into a volume at 20°C and 760 mmHg.

- (1) Carbon Monoxide : When 1050 ± 50 mL of Nitrous Oxide is passed through a CO detection tube at a specified flow rate, the change in the tube should be nor more than 10 ppm per volume.
- (2) Nitrogen Oxide : When 550 ± 50 mL of Nitrous Oxide is passed through a NO-NO₂ detection tube at a specified flow rate, the change in the tube should not be more than 1 ppm per volume.
- (3) Nitrogen Dioxide : While preventing frosts formation on the tube to ensure complete vaporization, 550 ± 50 mL of Nitrous Oxide is passed through a NO-NO₂ detection tube at a specified flow rate. The change in the tube should not be more than 1 ppm per volume.
- (4) Halogen : When 1050 ± 50 mL of Nitrous Oxide is passed through a Cl detection tube at a specified flow rate, the change in the tube should not be more than 1 ppm per volume.
- (5) Arsenic and Phosphorus : Using a porous gas distributing head(pore size 60 ~ 100µm) with a glass tube (packed with cotton, which is wetted with lead acetate solution) 10L of Nitrous Oxide is bubbled through 5 mL of a mixed solution of diethylthiocarbamate silver quinoline solution at the rate of 1.0L per minute. The color of the solution should not be change.
 - Diethylthiocarbamate silver quinoline solution : 50 mg of finely powdered silver nitrate is dissolved in 100 mL of quinoline, where 0.2 g of diethylthiocarbamate is added. This solution is prepared just before use.

Assay Nitrous Oxide is drawn into a syringe from a polyvinyl chloride tubes from a gas with drawing valve. It is then injected into a gas chromatography and tested. By comparing with air-helium gas standard, the amount of air reduced from 100, which is obtained as volume should not be less than 97.0%.

Operation Condition

- Column : a glass or stainless tube with inner diameter of 4 mm and length 6 m

- Column Filler : porous glass which can separate nitrogen and oxygen from NO or its equivalent
- Detector : thermal conductivity detector (TCD)
- Carrier gas : helium

γ -Nonalactone



Chemical Formula: $C_9H_{16}O_2$

Molecular Weight: 156.23

Synonyms: Nonano-1,4-lactone; Gamma-Amyl
butyrolactone

CAS No.: 104-61-0

Compositional Specifications of γ -Nonalactone

Content γ -Nonalactone should contain not less than 98.0% of γ -nonalactone ($C_9H_{16}O_2$).

Description γ -Nonalactone is a colorless to light yellow, transparent liquid having a sweet coconut-like odor.

Identification To 1 mL of γ -Nonalactone, add 7 mL of sodium hydroxide solution. and shaking and heating in water bath, γ -nonalactone almost dissolves, and its characteristic odor disappears. When the solution is acidified with dilute sulfuric acid, and shaking and heating in water bath, fat is separated and a characteristic odor is generated.

Purity (1) Specific Gravity : Specific gravity of γ -Nonalactone should be within a range of 0.958 ~ 0.966
(2) Refractive Index : Refractive Index n_D^{20} of γ -Nonalactone should be within a range of 1.446 ~ 1.450
(3) Clarity and Color of Solution : When 1 mL of γ -Nonalactone is dissolved in 5 mL of 60% ethanol, the solution should be clear.
(4) Acid Value : Acid value of γ -Nonalactone is tested by Acid Value in Flavoring Substance Test. It should not be more than 2.

Assay Accurately weigh about 1 g of γ -Nonalactone, and test by Ester Value in Flavoring Substances Test.

1 mL of 0.5 N alcoholic potassium hydroxide = 78.11 mg of $C_9H_{16}O_2$

Octyl Aldehyde

n-Octanal

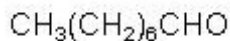

Chemical Formula: $\text{C}_8\text{H}_{16}\text{O}$

Molecular Weight: 128.22

Synonyms: n-Octanal; Caprylic aldehyde

CAS No.: 124-13-0

Compositional Specifications of Octyl Aldehyde

Content Octyl Aldehyde should contain not less than 92.0% of octyl aldehyde ($\text{C}_8\text{H}_{16}\text{O}$).

Description Octyl Aldehyde is a colorless or slightly yellowish, transparent liquid having a characteristic odor.

Identification (1) To 1 mL of Octyl Aldehyde, add 4 mL of sodium hydrogen sulfite solution, and shake. The solution evolves heat immediately, and crystalline lumps are formed.

(2) To 1 mL of Octyl Aldehyde, add 1 g of hydroxylamine hydrochloride, 5 mL of ethanol, and 5 mL of pyridine. Equip with a reflux condenser, and heat for 30 minutes in a water bath while shaking occasionally, evaporate the solvent, and cool. Crystals are deposited. Add 10 mL of water, shake, collect the crystals by filtration, and recrystallize, using 60% alcohol. The melting point is approximately 60°C

Purity (1) Specific Gravity : Specific gravity of Octyl Aldehyde should be within a range of 0.810 ~ 0.830.

(2) Refractive Index : Refractive Index n_D^{20} of Octyl Aldehyde should be within a range of 1.417 ~ 1.425.

(3) Clarity and Color of Solution : When 1 mL of Octyl Aldehyde is dissolved in 3 mL of 70% alcohol, the solution be clear.

(4) Acid Value : Acid value of Octyl Aldehyde is tested by Acid Value in Flavoring Substance Test. It should not be more than 10.

Assay Accurately weigh about 1 g of Octyl Aldehyde, and proceed as directed under Method 1 in Aldehyde and Ketone Content in Flavoring Substances Tests. In this procedure, allow the mixture to stand for 15 minutes.

1 mL of 0.5 N alcoholic solution of potassium hydroxide = 64.11 mg of $\text{C}_8\text{H}_{16}\text{O}$

Oleic Acid

(z)-9-Ocatadecanoic acid

Chemical Formula: $C_{18}H_{34}O_2$

Molecular Weight: 282.47

INS No.: 570

Synonyms: (Z)-9-Octadecenoic acid

CAS No.: 112-80-1

Definition Oleic Acid is a unsaturated fatty acid obtained from fats. Its major component is oleic acid ($C_{18}H_{34}O_2$).

Compositional Specifications of Oleic Acid

Description Oleic Acid is colorless ~ pale yellow oily liquid.

Purity (1) Acid Value : When 0.5 g of Oleic Acid is precisely weighted, and proceeded as directed under Acid value in Fats Test, the Acid value should be 196~204.

(2) Solidification point : Solidification point of Oleic Acid should not be more than 10°C.

(3) Lead : When 5.0 g of Oleic Acid is tested by Atomic Absorption Spectrophotometry or Inductively Coupled Plasma Emission Spectroscopy, its content should not be more than 1.0 ppm.

(4) Arsenic : It should be no more than 4.0 ppm tested by Arsenic Limit Test.

(5) Mercury : When Oleic Acid is tested by Mercury Limit Test, its content should not be more than 1.0ppm.

(6) Iodine Value : Approximately 0.3 g of Oleic Acid is precisely weighted into a 500 mL Erlenmeyer flask with a stopper which contains 20 mL of 1 : 1 mixture of glacial acetic acid : cyclohexane and 25 mL of Weiss solution. A stopper is placed on the flask which is vigorously shaken and set aside for 1 hour in a dark place. 20 mL of potassium iodide solution and 100 mL of water(previously boiled and cooled) are added to the flask. The excess iodine is titrated with 0.1 N sodium thiosulfate solution. 0.1 N sodium thiosulfate solution is added drop wise until yellow color disappears. Starch solution is added and the titration is continued until the blue color disappears completely. Near the end point, the flask is vigorously shaken with a stopper. Separately, a blank test is carried out by the same procedure. Iodine value is obtained by the following equation and it should be 83 ~ 103.

$$\text{Iodine Value} = \frac{(B-S) \times 1.269}{\text{weight of the sample(g)}}$$

B : Consumed amount of 0.1 N sodium thiosulfate solution in the blank test (mL)

S : Consumed amount of 0.1 N sodium thiosulfate solution in the test for sample (mL)

- (7) Saponification Value : 3 g of Oleic Acid is precisely weighted into a 250 mL flask, where 50 mL of 0.5 N alcoholic solution of potassium hydroxide is added. After attaching a reflux condenser, the solution is saponified for 30 ~ 60 minutes. This solution is used as test solution, tested under Saponification value in Fats Test, boiled (red color appears again) and titrated again until the red color disappears. Saponification value should be 196~206.
- (8) Unsaponifiable matter : 5 g of Oleic Acid is precisely weighted into a 250 mL flask, where 2 g of potassium hydroxide and 40 mL of alcohol are added and gently refluxed for 1 hour with a reflux condenser. The solution transfer into a separatory funnel (3.5 cm diameter × 30 cm length with 40 mL, 80 mL, and 130 mL scale marks) with a stopcock. The flask is washed with sufficient amount of alcohol, which is added to the funnel (total volume = 40 mL). The flask is washed with warm and cold water, which is added to the funnel (total volume = 80 mL). Finally, the flask is washed with a few mL of petroleum ether, which is added to the funnel. Cool the solution, 50 mL of petroleum ether is added to the funnel. The funnel is shaken vigorously for 1 minute and then settled to separate two phases completely. The supernatant ether layer is collected in a 500 mL separatory funnel with a stopcock. The aqueous layer is again extracted 6 times with 50 mL each of ether. These extracts are added to the first extract. The combined extracts are washed with 25 mL of 10% alcohol. This procedure is repeated until the aqueous layer doesn't get colorized by phenolphthalein TS. When this is accomplished, aqueous phase is discarded and the ether extract transfer into a pre-weighted beaker. With 10 mL of ether, the funnel is washed, which is added to the beaker. Ether layer is evaporated to dryness in a water bath, which is then dried at 100°C for 30 minutes until the weight becomes constant. Then the residue is cooled in a desiccator and weighted. The residue dissolve in 50 mL of warm alcohol (neutralized with sodium hydroxide using phenolphthalein as an indicator). The resulting solution is titrated with 0.02 N sodium hydroxide solution until a pale red color persists. The amount of oleic acid is obtained by multiplying the consumed amount of sodium hydroxide solution with 5.659 (mg). The exact amount of unsaponifiables is obtained by subtracting the amount of fatty acid (as oleic acid) from the amount of residues. The content of unsaponifiable matter is calculated by the following equation and it should not be more than 2.0%.

$$\text{Unsaponifiable matter(\%)} = \frac{\text{content of residue(mg)} - \text{content as oleic acid(mg)}}{\text{weight of the sample(g)}} \times \frac{100}{1,000}$$

Water Content Water content of Oleic Acid proceed as directed under water determination (Karl-Fisher Titration) and should not be more than 0.2%..

Residue on Ignition When Residue on Ignition analysis is done with accurately weighted 10 g of Oleic

Acid, the amount of residue on Ignition should not be more than 0.01%.

Oleoresin Paprika

INS No.: 160c

Synonyms: Paprika oleoresin; Paprika extract

CAS No.: 68917-78-2

Definition Paprika Extract colorant is a carotinoid colorant that is obtained by extracting fruits of paprika (*Capsicum annum* L.) of solanaceae with organic solvents (extracting solvent for spices such as oleoresin). Its major colorant component is capsanthin. Dilutant, antioxidant, or other food additives (emulsifier, thickening agent, etc) can be added for the purpose of color value adjustment and quality preservation.

Compositional Specifications of Paprika Extract colorant

Content Color Value (ASTA) of Paprika Extract colorant should be higher than the labeled value.

Description Paprika Extract colorant is orange ~ dark brown liquid, paste, or powder with a slight characteristic odor.

Identification (1) Test Solution obtained in Color Value section shows the maximum absorption at about 453 nm or 470 nm.

(2) When 2 mL of sulfuric acid is added to 0.5 g of Paprika Extract colorant, the color of the liquid changes from orange to blue.

(3) When antimony trichloride solution is added to Paprika Extract colorant, it developed a blue.

Purity (1) Arsenic : It should be no more than 4.0 ppm tested by Arsenic Limit Test.

(2) Lead : When 5.0 g of Paprika Extract colorant is tested by Atomic Absorption Spectrophotometry or Inductively Coupled Plasma Emission Spectroscopy, its content should not be more than 2.0 ppm.

(3) Cadmium : When 5.0 g of Paprika Extract colorant is tested by Atomic Absorption Spectrophotometry or Inductively Coupled Plasma Emission Spectroscopy, its content should not be more than 1.0 ppm.

(4) Mercury : When 0.1 g of Paprika Extract colorant is tested by Mercury Test Method, its content should not be more than 1.0ppm.

(5) Residual Solvents : When Paprika Extract colorant is tested by the following test method, it should contain,

Methylene chloride, trichloroethylene	Not more than 30ppm (individual or sum if used together)
Acetone	Not more than 30ppm
Isopropyl alcohol	Not more than 50ppm
Methyl alcohol	Not more than 50ppm
Hexane	Not more than 25ppm

Test Method

- ① Distilling head : A clevenger trap, that is designed to used for oils (heavier than water), is used.



(a) For oils heavier than water

(b) For oils lighter than water

Distilling head : Clevenger Traps (Units : mm)

② Agents

- Toluene : The purity of toluene for this test should be such that it does not contain any solvents that are measured in this test as determined by gas chromatography using the following column or its equivalent.

- A) 35~80 mesh Chromosorb W Ucon 75 H 90,000
- B) 35~80 mesh Chromosorb W Ucon LB 135 20%
- C) 60~80 mesh Chromosorb W Ucon LB 1715 15%
- D) Porapak Q 50~60 mesh

Test proceed as directed under Test Procedure. The same amount of toluene is injected as the amount used in solvent analysis. If any peaks for interfering impurities appear before the toluene peak, they should be removed by separation.

- Benzene : It should not contain any interfering impurities. Its purity is measured by the same method as toluene.
- Detergent & antifoam : It should not contain a volatile matter. If it does, an aqueous solution of the material should be heated until a volatile matter is removed.
- Reference Solution A : Toluene containing 2,500ppm of benzene is prepared. If the toluene contains benzene as the only impurity, the concentration should be adjusted so that it contains 2,500ppm of

benzene as determined by gas chromatography.

• Reference Solution B : A solution containing 0.63% v/w of acetone in water is prepared.

③ Preparation of Test Solution

• Test Solution A (for solvents except methyl alcohol) : Small amount of detergent & antifoam, 50 mL of water, 10 g of anhydrous sodium sulfate, 1 mL of Reference Solution A, and 50 g of sample are added in a 250 mL single neck round bottom flask with a 24/40 ground joint. 400 mm reflux condenser, distilling head, and a collector is connected to the flask and 15 mL of distillate is collected. 15 g of anhydrous potassium carbonate is added to the distillate. It is then cooled while shaking. It is allowed to stand until layer is separated. The toluene layer contains all the solvents except methyl alcohol and is used in the following Test Procedure. The aqueous layer is used as Test Solution B.

• Test Solution B (for methyl alcohol only) : 50 mL of aqueous layer obtained in Test Solution A is transferred into a round bottom flask, where 2 ~ 3 glass balls and 1 mL of Reference Solution B are added. Approximately 1 mL of distillate is collected. This distillate contains acetone as internal standard substance and methyl alcohol in the sample. It is used in the following Test Procedure.

④ Test Procedure : Gas chromatography equipped with a thermally conductive detector and sample injection port is used. Under typical operation conditions, a 0.3 mm × 2 m column (isothermalized at 70~80°C) is used. Flow rate of a carrier gas is 50~80 mL/minute and injected amount of sample is 15~20 µl. The choice of a column depends on the components to be analyzed and is up to the analyzer to a certain degree. The columns described in A), B), C), and D) in Toluene section are used as follows.

A) This column separates acetone and methyl alcohol from the aqueous layer. This also can be used to analyze or separate of hexane, acetone, and trichloro ethylene in the toluene layer obtained in Test Solution A. The order of effluence is acetone, methyl alcohol and water or hexane, acetone, isopropyl alcohol+methylene chloride, benzene, trichloro ethylene, and dichloro ethylene+toluene.

B) This column separates methylene chloride, isopropyl alcohol, and dichloro ethylene. The order of effluence is hexane+acetone, methylene chloride, isopropyl alcohol, benzene, dichloro ethylene, trichloro ethylene, and toluene.

C) This is the most generally used column except for methyl alcohol. The order of effluence is hexane, acetone, methylene chloride, isopropyl alcohol, benzene, and dichloro ethylene+trichloro ethylene, and toluene.

D) This column is used to measure methyl alcohol, which appears right after a big peak of water.

⑤ Preparation of Calibration Curve : A mixture of benzene and solvent, previously known concentration, in toluene is injected into gas chromatography. The response of the detector for the previously known ratios of solvents is measured. The peak(area or height) of benzene and the solvents in toluene

should be the same as those of the sample. Peaks areas for the solvents are calculated according to benzene and the weighing factor F is calculated as follows.

$$F(\text{solvent}) = \frac{\text{wt\% solvent}}{\text{wt\% benzene}} \times \frac{\text{peak area of benzene}}{\text{peak area of solvent}}$$

When it is compared with benzene recovery rate, the recovery rates of various solvents from oleoresin sample are as follows.

hexane 52%, acetone 85%, isopropyl alcohol 100%, methylene chloride 87.5%, trichloro ethylene 113%, dichloro ethylene 102%, methyl alcohol 87%

⑥ Calculation : The concentration of residual solvents (except for methyl alcohol) is calculated by the following equation.

$$\text{Residual Solvent} = \frac{43.4 \times F(\text{weight}) \times 100}{\text{solvent recovery rate \%}} \times \frac{\text{peak area of solvent}}{\text{peak area of benzene}}$$

43.4 is the concentration(ppm) of internal standard benzene related to 50 g of oleoresin sample used in the test.

$$\text{Methyl alcohol} = \frac{100 \times F(\text{methyl alcohol})}{0.87} \times \frac{\text{peak area of methyl alcohol}}{\text{peak area of acetone}}$$

100 is the concentration(ppm) of internal standard acetone related to 50 g of oleoresin sample used in the test.

(6) Spicy Taste : 400 mg of oleoresin paprika is weighed into a 100 mL volumetric flask, which is filled with alcohol. It is then mixed by shaking and settled to precipitate. 60 mL of 10% sugar solution in water is added to 0.15 mL of the supernatant. When 5 people consume 5 mL each of the resulting solution, should not be more than 3 people who feel the spicy taste.

Assay (Color Value) Appropriate amount of oleoresin paprika, the absorbance to be measured will be within a range of 0.2 to 0.7, is precisely weighed into a 100 mL volumetric flask and dissolved in acetone to make total volume 100 mL. (If it is water soluble, water is used instead of acetone). After settling for 2 minutes, 1 mL of this solution is diluted to 100 mL with acetone (For water soluble sample, diluting with acetone may cause severe turbidity. In this case, 1 mL of alkaline lead acetate solution (1→50) is added to the solution and then diluted to 100 mL with acetone. It is then centrifuged and the supernatant is used.). Absorbance(A_s) of the resulting solution is measured at 460 nm with 1 cm cell

using acetone as a reference. Using the same method, absorbance of NBS (National Bureau of Standard) color standard glass plate 2030 (AF) is measured.

$$\text{Color Value(ASTA)} = \frac{A_s \times 164 \times F}{W} \times 10$$

W : Weight of sample(g)

ASTA : American Spice Trade Association

F : AN/AF, where AN is absorbance of glass filter defined by NBS. Therefore, F is an activity for correcting of the instrument.

* If colorimetric glass plate is not available, a color standard solution is used.

◦ Color standard Solution : $\text{CoSO}_4(\text{NH}_4)_2\text{SO}_4 \cdot 6\text{H}_2\text{O}$ is dried for 1 week in a desiccator with dried silica gel. 0.3005 g of $\text{K}_2\text{Cr}_2\text{O}_7$ and 34.960 g of dried $\text{CoSO}_4(\text{NH}_4)_2\text{SO}_4$ are dissolved in 1.8 M sulfuric acid to make 1,000 mL. The absorbance of this solution at 460 nm with 1 cm cell is 0.600.

Onion Color

Definition Onion Color is a pigment obtained by extracting bulbs of Onions (*Allium cepa* L.) of liliaceae with ethyl alcohol. Its major pigment component is Quercetin ($C_{15}H_{10}O_7 = 302.23$) of flavonoids. Dilutant, stabilizer, or solvent can be added for the purpose of color value adjustment and quality preservation.

Compositional Specifications of Onion Color

Content Color value ($E_{1cm}^{10\%}$) of Onion Color should be more than the indicated value.

Description Onion Color is brown liquid, paste, powder, or paste with a slight characteristic scent.

Identification (1) Citrate buffer (pH 7.0) solution (1→100) of Onion Color is yellowish ~ reddish brown in color.

(2) When the solution in (1) is acidified with hydrochloric acid, the pigment becomes insoluble and brown precipitates are formed.

(3) When ferric chloride solution is added to the solution in (1), milky white precipitates are formed.

Purity (1) Arsenic : It should be no more than 4.0 ppm tested by Arsenic Limit Test.

(2) Lead : When 5.0 g of Onion Color is tested by Atomic Absorption Spectrophotometry or Inductively Coupled Plasma Emission Spectroscopy, its content should not be more than 10.0 ppm.

Assay (Color Value) Appropriate amount of Onion Color is precisely weighted so that the measuring absorption of Onion Color is within 0.3 ~ 0.7 and dissolved in 5 mL of sodium carbonate (anhydrous) solution (1→200). Citrate buffer solution with pH 7.0 is added so that the total volume is 100 mL accurately. 5 mL of this solution is diluted to 100 mL with Citrate buffer solution with pH 7.0 (Test Solution). If necessary, the solution is centrifuged and the supernatant is used. Using Citrate buffer solution with pH 7.0 as a reference solution, absorption A is measured at 500 nm wavelength with 1cm path length. Color value is obtained using the following equation.

$$\text{Color Value } (E_{1cm}^{10\%}) = \frac{A \times 200}{\text{weight of the sample(g)}}$$

◦ Citrate buffer solution (pH 7.0)

Solution 1 : 1 l of solution containing 21 g of citric acid ($C_6H_8O_7 \cdot H_2O$)

Solution 2 : 1 l of solution containing 71.6 g of dibasic sodium phosphate ($Na_2HPO_4 \cdot 12H_2O$)

Solution 1 and Solution 2 are mixed well (35 : 165) and its pH is adjusted to 7.0.

γ -Oryzanol

Definition γ -Oryzanol is obtained by the following procedure. Rice bran or embryo bud oil is distributed with hydrous ethyl alcohol and hexane or acetone at room temperature. It is then obtained from the fraction of hydrated ethyl alcohol or by treating with resin and purified. Its component is γ -Oryzanol.

Compositional Specifications of γ -Oryzanol

Content The content (mg) of Oryzanol A ($C_{40}H_{58}O_4$) of γ -Oryzanol should be more than the indicated amount.

Description γ -Oryzanol is pale yellow ~ yellow crystalline powder. It can be scentless or have a slight characteristic scent.

Identification (1) When 0.01 g of γ -Oryzanol is dissolved in 10 mL of alcoholic potassium hydroxide solution, this solution is yellow color.

(2) When 0.01 g of γ -Oryzanol is dissolved in 5 mL of chloroform, where 4 drops of sulfuric acid is added and mixed by shaking, the solution becomes yellow. When 10 drops of anhydrous acetic acid are added, the color of the solution changes to reddish violet then slowly to green.

(3) When 0.01 g of γ -Oryzanol is dissolved in 5 mL of chloroform, where 5 drops of sulfuric acid is added and mixed by shaking and then settled, chloroform layer is pale yellow and aqueous layer is orange in color.

(4) A solution of material in n-heptane (1→100,000) shows maximum absorptions at 229~233 nm, 289~293 nm, 313~317 nm.

Purity (1) Arsenic : It should be no more than 4.0 ppm tested by Arsenic Limit Test.

(2) Lead : When 5.0 g of γ -Oryzanol is tested by Atomic Absorption Spectrophotometry or Inductively Coupled Plasma Emission Spectroscopy, its content should not be more than 2.0 ppm.

Loss on Drying When γ -Oryzanol is dried for 3 hours at 105°C, the weight loss should not be more than 0.5%.

Residue on Ignition When Residue on Ignition is done with precisely weighted material, the amount of residue should not be more than 0.1%.

Assay Dry γ -Oryzanol, weight precisely 0.05 g of γ -Oryzanol, and dissolve the sample in 70 mL of n-heptane by heating at 70~80°C. N-heptane is added to bring the total volume to 100 mL accurately. 2 mL of this solution is further diluted to 100 mL with n-heptane (Test Solution). Using n-heptane as a reference, absorption A of Test Solution is measured at the maximum absorption band near 315 nm with a path length of 1cm. The content of oryzanol A is obtained by the following equation.

$$\text{Content of Oryzanol A (mg)} = \frac{A \times 5,000}{\text{Weight of the sample(g)} \times}$$

359

Oxalic Acid

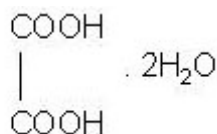

Chemical Formula: $\text{C}_2\text{H}_2\text{O}_4 \cdot 2\text{H}_2\text{O}$

Molecular Weight: 126.07

CAS No.: 6153-56-6

Compositional Specifications of Oxalic Acid

Content Oxalic acid should contain within a range of 99.5 ~ 101.0% of oxalic acid ($\text{C}_2\text{H}_2\text{O}_4 \cdot 2\text{H}_2\text{O}$).

Description Oxalic acid occurs as colorless crystals. It is odorless.

Identification (1) Oxalic Acid is sublimed by heating.

(2) To 1 mL of Oxalic Acid solution (1→10), add 2 drops of sulfuric acid and 1 mL of potassium permanganate solution, and heat. The color of the solution disappears.

(3) Make Oxalic Acid solution (1→10) alkaline with ammonia solution and add 1 mL of calcium chloride solution. A white precipitate is formed.

Purity (1) Clarity and Color of Solution : When 1 g of Oxalic Acid is dissolved in 20 mL of water by boiling, the solution should be colorless and should not be more than almost clear.

(2) Sulfate : To 1 g of Oxalic Acid, add 20 mL of water and 1 mL of sodium carbonate solution, evaporate to dryness in a water bath, heat gradually, and heat treated to 600~700°C. To the residue, add 10 mL of water and 0.5 mL of nitric acid, boil, add 2 mL of hydrochloric acid, and evaporate to dryness in a water bath. Add water to the residue to make 100 mL, and filter. Measure 25 mL of the filtrate, add 1 mL diluted hydrochloric acid, and use as the test solution. When the test solution is tested by Sulfate Limit Test content, its content should not be more than the amount correspond to 0.4 mL of 0.01 N sulfuric acid.

(3) Arsenic : It should be no more than 4.0 ppm tested by Arsenic Limit Test.

(4) Lead : When 5.0 g of Oxalic Acid is tested by Atomic Absorption Spectrophotometry or Inductively Coupled Plasma Emission Spectroscopy, its content should not be more than 2.0 ppm.

Residue on Ignition When thermogravimetric analysis is done with 1 g of Oxalic Acid, the residue should not be more than 0.3%.

Assay Accurately weigh about 1 g of Oxalic Acid, dissolve in water to make 250 mL, measure accurately 50 mL, add 3 mL of sulfuric acid, warm to about 80°C, and titrate with 0.1 N potassium permanganate while hot.

1 mL of 0.1 N potassium permanganate = 6.304 mg of $C_2H_2O_4 \cdot H_2O$

Oxygen

Chemical Formula: O₂

INS No.: 948

Molecular Weight: 16.00

CAS No.: 7782-44-7

Compositional Specifications of Oxygen

Content Oxygen should contain no less than 99.0% of oxygen (O₂).

Description Oxygen is colorless scentless gas.

Identification Upon contact with a piece of wood of which the flame is extinguished, a violent flame is generated.

Purity When the volume of Oxygen is measured, it should be converted to the volume at 20° and under 760 mmHg.

(1) Carbon Dioxide : Both ends of a carbon dioxide detecting tube are broken off. One end is connected to an oxygen cylinder and the other to an appropriate flow meter. When approximately 1050 ± 50 mL of oxygen is passed through at an appropriate flow rate for the tube, the content of carbon dioxide should not be more than 300 µl/l.

(2) Carbon Monoxide : Both ends of a carbon monoxide detecting tube are broken off. One end is connected to an oxygen cylinder and the other to an appropriate flow meter. When approximately 1050 ± 50 mL of oxygen is passed through at an appropriate flow rate for the tube, the content of carbon monoxide should not be more than 10 µl/l.

(3) Scent : When the valve of an oxygen cylinder is gently opened and the scent of oxygen is smelled (care must be taken to avoid direct facial contact), there should not be any noticeable scent.

Assay

Apparatus

A is a 100 mL gas burette with a two-way stopcock. Scale marks for b~c, d~e, and e~f are at 0.1 mL, while those for c~d are at 2 mL. A is connected to a alidade B and a thick rubber hose. Approximately 50% volume of A and B is filled with ammonium chloride · ammonia solution. An inlet g of gas pipette C is filled (up to its top) with a finely coiled copper wire (diameter : Not more than 2 mm), filled with 125 mL of ammonium chloride · ammonia solution, plugged with a rubber stopper i, and connected to A with a think rubber tube.

Procedure : a is opened and B is lowered. The solution in g is sucked up to the stopcock of a and stopcock a is closed. sample inlet h of a is opened and B is raised so that A and h are filled with ammonium chloride-ammonia solution. Then a is closed and the sample cylinder is connected to h. Again, a is opened and B is lowered and approximately 100 mL of sample is introduced. The opening to c in a is opened and B is raised so that the sample is flown into g then a is closed. c is gently shaken back and forth. Unadsorbed gas is flown back to A by opening a and lowering B and its volume is measured. This operation is repeated until the volume of unadsorbed gas becomes constant. The volume

at this point is measured V (mL). The oxygen content is obtained by the following equation. When ammonium chloride-ammonia solution is freshly replaced, the above Procedure are repeated 4 times and the average is taken. V and the volume of the sample are converted to volumes at 20° and under 760 mmHg.

$$\text{Oxygen(O}_2\text{) content(\%)} = \frac{\text{converted volume of sample(mL)} - \text{converted V(mL)}}{\text{converted volume of sample(mL)}} \times 100$$

b~c = 0.1mL 눈금
 c~d = 0.1mL 눈금
 d~e = 0.1mL 눈금
 e~f = 0.1mL 눈금
 눈금선은 적색으로 한다.

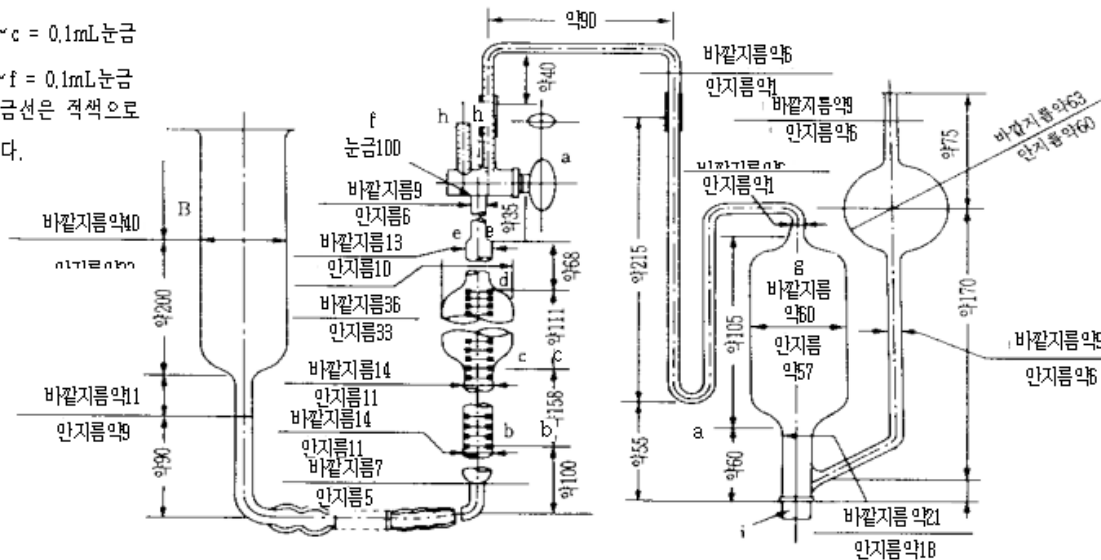

Oxystearin

INS No.: 387

CAS No.: 8028-45-3

Definition Oxystearin is a mixture of partially oxidized stearic acid and glyceride of other fatty acids.

Compositional Specifications of Oxystearin

Description Oxystearin is yellowish brown ~ pale brown fatty or waxy material.

Purity (1) Acid value : Approximately 8 g of Oxystearin is precisely weighed and dissolved in 125 mL mixture of iso-propyl alcohol and toluene (1:1), which is heated if necessary. After adding 2 mL of phenolphthalein solution, the solution is titrated with 0.1 N potassium hydroxide solution. Acid value is calculated by the following equation and it should not be more than 15.

(2) Lead : When 5.0 g of Oxystearin is tested by Atomic Absorption Spectrophotometry or Inductively Coupled Plasma Emission Spectroscopy, its content should not be more than 2 ppm.

(3) Hydroxyl Value : Approximately 3 g of Oxystearin is accurately weighed into a 250 mL flask with a stopper. Add 5 mL of pyridine-anhydrous acetic acid mixture (3:1), a reflux condenser is attached. It is then heated for 1 hour in a water bath. 10 mL of water is added through the condenser and it is heated again for 10 minutes. After cooling, 15 mL of n-butyl alcohol is added through the condenser, the condenser is removed, and inner wall of the flask is washed with 10 mL of n-butyl alcohol. 1 mL of phenolphthalein solution is added to the flask and the solution is titrated with 0.5 N alcoholic solution of potassium hydroxide. The consumed amount of alcoholic solution is S. Separately, 5 mL of pyridine-anhydrous acetic acid is treated as same as the test solution and the consumed amount of alcoholic solution is B. To correct for free acid, approximately 10 g of Polysorbate 20 is accurately weighed and dissolved in 10 mL of pyridine. After adding 1 mL of phenolphthalein solution, the solution is titrated with 0.5 N alcoholic solution of potassium hydroxide. The consumed amount of alcoholic solution is A. Hydroxyl value, that is calculated by the following equation, should be within a range of 96 ~ 108.

$$\text{Hydroxyl Value} = \frac{[B + (WA / C) - S] \times 28.05}{W}$$

W : Amount of sample used in acetylation (g)

C : Amount of sample used for quantitative analysis of free acid (g)

(4) Iodine Value : Approximately 0.3 g of Oxystearin is accurately weighed into a 500 mL Erlenmeyer flask with a stopper and 20 mL of glacial acetic acid/cyclohexane, 1:1, v/v is added to dissolve the

material. After adding 25 mL of Weiss solution, a stopper is placed and let stand in the dark for 1 hour where the iodine value is <150 and for 2 hours where the iodine value is ≥150. 20 mL of potassium iodide solution and 100 mL (previously boiled and cooled) are added to the flask. The excess iodine is titrated with 0.1 N sodium thiosulfate solution. Sodium thiosulfate solution is added drop wise until yellow color disappears. Starch solution is added and the titration is continued until the blue color disappears completely. Near the end point, the flask is vigorously shaken with a stopper. Separately, a blank test is carried out by the same procedure.

$$\text{Iodine Value} = \frac{(B - S) \times 1.269}{\text{weight of the sample(g)}}$$

B : Consumed amount of 0.1 N sodium thiosulfate solution in the blank test (mL)

S : Consumed amount of 0.1 N sodium thiosulfate solution in the test for sample(mL)

- (5) Refractive Index : Refractive Index n_D^{40} should be within a range of 1.465~1.467.
- (6) Saponification Value : 3 g of Oxystearin is precisely weighed into a flask, where 25 mL of 0.5 N alcoholic solution of potassium hydroxide is added. After attaching a reflux condenser, the solution is saponified for 1 hour, test solution. The test solution is proceeded as directed under saponification value in Fats Test. The saponification value of the solution should be within a range of 225 - 240.
- (7) Unsaponifiables : Oxystearin is tested by Purity (8) for [Carnauba Wax]. The content should not be more than 0.8%.

Ozone Water

Definition Ozone water is obtained by dissolving ozone gas generated from an ozone apparatus and main ingredient is ozone.

Compositional Specifications of Ozone water

Content When Ozone water is quantified, it should not be less than Ozone (O₃) 1.0mg/l.

Description Ozone water is colorless liquid with characteristic scent.

Identification 20 mL each of alizarin solution is taken to 200 mL of two flasks respectively. To the first flask, water without ozone is taken to make 200 mL, blank test solution. To another flask, a sample is taken from the below of alizarin solution using pipette or long-neck funnel to prevent the loss of ozone and the total becomes 200 mL, test solution. Immediately, measure absorbances of each solution at wavelengths of 548 nm, respectively, using 1 cm cell for analysis. When the absorption of test solution is lower than the absorption of blank test solution, ozone exists in sample.

Alizarin solution : 124.5mg of alizarin violet 3R is precisely weighed into a 1,000mL flask, 500mL of water is added and dissolved. Set aside for 24 hours. Then 20mg of sodium hexametaphosphate, 48.5g of ammonium chloride, 6.2mL of ammonium hydroxide (corresponds to 1.6 g of NH₃) are weighed, water is added to make 1,000 mL and set aside for 24 hours. The absorption of ten times diluted solution of this solution at 548nm is 0.155, and the pH is 8.1 ~ 8.5

Assay 10 mL each of indigo solution is taken to 50 mL of two flasks respectively. To the first flask, water without ozone is taken to make 15 mL, blank test solution. To another flask, a 5 mL sample is gradually taken along the inner wall of flask using pipette or long-neck funnel to prevent the loss of ozone and the total becomes 15 mL, test solution. Immediately, measure absorbances of each solution at wavelengths of 600 nm, respectively, using 1 cm cell. Measure the concentration of ozone in sample under following equation.(However, when chlorine exists, 1 mL of malonic acid is added before taking samples to each flask and proceed test in the same manner to correct the influence by interference).

$$\text{content of ozone (mg/l)} = 15\text{mL} \times D / (f \times b \times V)$$

D: Absorbance difference between test solution and blank test solution

b: Path length (cm)

V: Weight of sample(5mL)

f: 0.42(extinction coefficient of ozone)

Indigo undiluted standard solution : 0.770 g of potassium indigotrisulfonate) is weighed and dissolved in 500 mL of water, 1 mL of phosphate is added, mixed and make 1,000 mL with water.

Indigo test solution : 100mL of Indigo undiluted standard solution, 10 g of sodium phosphate, monobasic, 7mL of phosphate, water are added to make 1,000 mL and mixed.

Malonic acid solution : Water is added to 5 g of malonic acid to make 100 mL.

Palmitic Acid

Hexadecanoic acid

Chemical Formula: $C_{16}H_{32}O_2$

Molecular Weight: 256.43

INS No.: 570

Synonyms: Hexadecanoic acid

CAS No.: 57-10-3

Definition Palmitic Acid is a solid fatty acid obtained from fats. It consists of a mixture of palmitic acid ($C_{16}H_{32}O_2$) and stearic acid ($C_{18}H_{36}O_2$). Its major component is palmitic acid ($C_{16}H_{32}O_2$).

Compositional Specifications of Palmitic Acid

Description Palmitic Acid is white ~ pale yellow crystalline solid or powder.

Purity (1) Acid Value : When 0.5 g of Palmitic Acid is precisely weighted, and proceeded as directed under Acid value in Fats Test, the Acid value should be 204~220.

(2) Solidification point : Solidification point of Palmitic Acid should be 53.3~62.0.

(3) Lead : When 5.0 g of Palmitic Acid is tested by Atomic Absorption Spectrophotometry or Inductively Coupled Plasma Emission Spectroscopy, its content should not be more than 1.0 ppm.

(4) Arsenic : It should be no more than 4.0 ppm tested by Arsenic Limit Test.

(5) Mercury : When Palmitic Acid is tested by Mercury Limit Test, its content should not be more than 1.0ppm.

(6) Iodine Value : Approximately 12.5 g of Palmitic Acid is precisely weighted into a 500 mL Erlenmeyer flask with a stopper which contains 20 mL of 1 : 1 mixture of glacial acetic acid : cyclohexane and 25 mL of Weiss solution. A stopper is placed on the flask which is vigorously shaken and set aside for 1 hour in a dark place. 20 mL of potassium iodide solution and 100 mL of water (previously boiled and cooled) are added to the flask. The excess iodine is titrated with 0.1 N sodium thiosulfate solution. 0.1 N sodium thiosulfate solution is added drop wise until yellow color disappears. Starch solution is added and the titration is continued until the blue color disappears completely. Near the end point, the flask is vigorously shaken with a stopper. Separately, a blank test is carried out by the same procedure. Iodine value is obtained by the following equation and it should not be more than 2.0.

$$\text{Iodine Value} = \frac{(B-S) \times 1.269}{\text{weight of the sample(g)}}$$

B : Consumed amount of 0.1 N sodium thiosulfate solution in the blank test (mL)

S : Consumed amount of 0.1 N sodium thiosulfate solution in the test for sample (mL)

(7) Saponification Value : 3 g of Palmitic Acid is precisely weighted into a 250 mL flask, where 50 mL of

0.5 N alcoholic solution of potassium hydroxide is added. After attaching a reflux condenser, the solution is saponified for 30 ~ 60 minutes. This solution is used as test solution, tested under Saponification value in Fats Test, boiled (red color appears again) and titrated again until the red color disappears. Saponification value should be 205~221.

(8) Unsaponifiable matter : 5 g of Palmitic Acid is precisely weighted into a 250 mL flask, where 2 g of potassium hydroxide and 40 mL of alcohol are added and gently refluxed for 1 hour with a reflux condenser. The solution transfer into a separatory funnel (3.5 cm diameter x 30 cm length with 40 mL, 80 mL, and 130 mL scale marks) with a stopcock. The flask is washed with sufficient amount of alcohol, which is added to the funnel (total volume = 40 mL). The flask is washed with warm and cold water, which is added to the funnel (total volume = 80 mL). Finally, the flask is washed with a few mL of petroleum ether, which is added to the funnel. Cool the solution, 50 mL of petroleum ether is added to the funnel. The funnel is shaken vigorously for 1 minute and then settled to separate two phases completely. The supernatant ether layer is collected in a 500 mL separatory funnel with a stopcock. The aqueous layer is again extracted 6 times with 50 mL each of ether. These extracts are added to the first extract. The combined extracts are washed with 25 mL of 10% alcohol. This procedure is repeated until the aqueous layer doesn't get colorized by phenolphthalein TS. When this is accomplished, aqueous phase is discarded and the ether extract Transfer into a pre-weighted beaker. With 10 mL of ether, the funnel is washed, which is added to the beaker. Ether layer is evaporated to dryness in a water bath, which is then dried at 100°C for 30 minutes until the weight becomes constant. Then the residue is cooled in a desiccator and weighted. The residue dissolve in 50 mL of warm alcohol (neutralized with sodium hydroxide using phenolphthalein as an indicator). The resulting solution is titrated with 0.02N sodium hydroxide solution until a pale red color persists. The amount of oleic acid is obtained by multiplying the consumed amount of sodium hydroxide solution with 5.659 mg. The exact amount of unsaponifiables is obtained by subtracting the amount of fatty acid (as oleic acid) from the amount of residues. The content of unsaponifiable matter is calculated by the following equation and it should not be more than 1.5%.

$$\text{Unsaponifiable matter(\%)} = \frac{\text{content of residue(mg)} - \text{content as oleic acid(mg)}}{\text{weight of the sample(g)}} \times \frac{100}{1,000}$$

Water Content Water content of Palmitic Acid is determined by water determination (Karl-Fisher Titration) and should not be more than 0.2%.

Residue on Ignition When Residue on Ignition analysis is done with accurately weighted 2 g of Palmitic Acid, the amount of residue should not be more than 0.1%.

Pancreatin

Definition Pancreatin is obtained by extracting pancreas of cows or pigs. It is an enzyme that can decompose starches, fats, and proteins. Diluent or stabilizer can be added for the purpose of activity adjustment and quality preservation.

Compositional Specifications of Pancreatin

Description Pancreatin is white ~ pale yellow powder with a characteristic scent.

Identification When Pancreatin is proceeded as directed under Activity Test, it should have the activity as Pancreatin.

Purity (1) Arsenic : It should be no more than 4.0 ppm tested by Arsenic Limit Test.

(2) Lead : When 5.0 g of Pancreatin is tested by Atomic Absorption Spectrophotometry or Inductively Coupled Plasma Emission Spectroscopy, its content should not be more than 5.0 ppm.

(3) Coliform Group : Pancreatin is tested by Microbiological Methods for Coliform Group in General Testing Methods in 「Standards and Specifications for Foods」. It should contain 30 or less per 1g of this product.

(4) Salmonella : Pancreatin is tested by Microbiological Methods for Salmonella in General Testing Methods in 「Standards and Specifications for Foods」. It should be negative (-).

(5) E. Coli : When Pancreatin is tested by Microbe Test Methods for E. Coli in General Test Method 「Standards and Specifications for Foods」, it should be negative (-).

Activity Test (Activity)

(1) Activity of Amylase

◦Preparation of Test Solution : When the amylase activity of Pancreatin is same as that of USP pancreatin standard, 40 mg of this additive is precisely weighted into a mortar, where 3 mL of phosphate buffer solution (pH 6.8) is added. It is then ground for 5 ~ 10 minutes and diluted to 100 mL with phosphate buffer solution (pH 6.8) (Test Solution). When the amylase activities are different, Test Solution is prepared (following the same procedure) so that 1 mL of the final dilution contains the same activity as 1 mL of Standard Solution.

◦Test Procedure : Four 250 mL round bottom flasks with stoppers are labeled as S, U, BS, and BU, respectively. To each flask, 25 mL of substrate solution, 10 mL of phosphate buffer solution (pH 6.8), and 1 mL of sodium chloride solution (11.7→1,000) are added. A stopper is placed on each flask, which is then mixed and set aside in a $25 \pm 0.1^\circ\text{C}$ until it is isothermalized. 2 mL each of 1 N hydrochloric acid is added to BU & BS, which are well mixed and placed in the water bath. 1 mL each of Test Solution is added to U & BU and 1 mL each of Standard Solution is added to S & BS, which are well mixed and placed in the water bath. After exactly 10 minutes, 2 mL each of 1N hydrochloric acid is added to S & U. While stirring continuously, 10mL each of 0.1N iodine solution is added to each flask, where 45 mL each of 0.1 N sodium hydroxide solution is immediately added. The flasks are set aside for 15 minutes at $15 \sim 25^\circ\text{C}$ in a dark place. After adding 4 mL each of 2 N sulfuric acid to each flask, it is titrated with

0.1 N sodium thiosulfate solution until blue color disappears. The consumed amounts of 0.1 N sodium thiosulfate solution for U, S, BU, and BS are V_U , V_S , V_{BU} , and V_{BS} , respectively.

Amylase activity of an enzyme is obtained by the following equation.

$$\text{USP Units/m} = \frac{C_s}{W_u} \times \frac{(V_{BU} - V_U)}{(V_{BS} - V_S)} \times 100$$

C_s : Amylase activity of Standard Solution (USP units/mL)

W_u : Amount of sample (mg)

Solutions

- Standard Solution : 20 mg of USP pancreatin standard is precisely weighted into a mortar, where 30 mL of phosphate buffer solution (pH 6.8) is added. It is ground for 5 ~ 10 minutes and diluted to 50 mL with phosphate buffer solution (pH 6.8) (Standard Solution). USP Units of amylase per 1 mL of this solution is calculated.
- Phosphate Buffer Solution (pH 6.8)
 - Solution 1 : 13.6 g of potassium phosphate, monobasic dissolve in 500 mL of water.
 - Solution 2 : 14.2 g of sodium phosphate, dibasic dissolve in 500 mL of water. 51 mL of Solution 1 and 49 mL of Solution 2 are well mixed. pH is adjusted to 6.8, if necessary.
- Substrate Solution : 10 mL of water is added to purified soluble starch (2.0 g as a dried form) and stirred. 160 mL of water is added to this mixture, which is continuously stirred and heated to boil. Cool the solution, water is added to bring the volume to 200 mL. This solution is freshly prepared before use.

(2) Activity of Lipase

- Preparation of Test Solution : 200 mg of Pancreatin is precisely weighted into a mortar. It is ground for 10 minutes with 3 mL of water. It is diluted with cold water so that 1 mL of the final dilution contains 8 ~ 16 USP units of lipase. This suspension is mixed prior to use maintaining at 4°C . 5 ~ 10 mL of this cold suspension is warmed to 20°C just before use (test solution).
- Test Procedure : 10.0 mL of substrate solution, 8.0 mL of tris buffer solution, 2.0 mL of sodium taurocholate solution, and 9 mL of water are added to a 50 mL receiving container with a cap and mixed. It is capped and continuously stirred in a water bath with a temperature controller. The mixture is isothermalized at $37 \pm 0.1^\circ\text{C}$ in the water bath. pH of the mixture is adjusted to 9.2 with 0.1 N sodium hydroxide solution. 1.0 mL of Test Solution is added to the mixture, which is titrated with 0.1 N sodium hydroxide solution for 5 minutes to keep pH 9.0 and consumed amount of 0.1 N sodium hydroxide solution (mL) per minute is recorded. Separately, the same procedure is carried out with Standard Solution and 0.1N sodium hydroxide solution consumption rate (mL/min) for Standard and Test Solution

is calculated.

Activity of lipase is obtained by the following equation.

$$\text{USP Units/mg} = \frac{V_A \times C_S}{V_S \times C_A} \times A$$

A : Activity of lipase of USP Standard Product (USP Units/mg)

V_S : 0.1N sodium hydroxide solution consumption rate (mL/min) for Standard Solution

V_A : 0.1N sodium hydroxide solution consumption rate (mL/min) for Test Solution

C_A : Concentration of Test Solution (mg/mL)

C_S : Concentration of Standard Solution (mg/mL)

Solutions

- Standard Solution : 200 mg of USP pancreatin standard is precisely weighted into a mortar. It is ground for 10 minutes with 3 mL of water. It is diluted with cold water so that 1 mL of the final dilution contains 8 ~ 16 UPS units of lipase (Standard Solution). This suspension is maintained at 4°C and mixed prior use. 5 ~ 15 mL of this cold suspension is warmed to 20°C just before use to for accurate measurement of volume.
- Arabic gum Solution : Arabic gum solution (1→10) is centrifuged until it becomes clear. Only the clear solution is used.
- Substrate Solution : 165 mL of Arabic gum solution, 20 mL of olive oil, and 15 g of ice are mixed using a homogenizer. The mixture is cooled to 5°C in an ice bath. It is then homogenized for 15 minutes at over 8,000 rpm .
- Tris Buffer Solution : 60 mg of tris(hydroxymethyl)aminomethane and 234 mg of sodium chloride dissolve in water (total volume = 100mL).
- Sodium tauro-cholate Solution : A solution is prepared so that it contains 80.0 mg of USP sodium tauro-cholate standard per 1 mL.

(3) Activity of Protease

- Preparation of Test Solution : 100 mg of Pancreatin is precisely weighted into a mortar. It is ground for 5 ~ 10 minutes with 3 mL of phosphate buffer solution (pH 7.5). It is diluted so that 1 mL of the final dilution contains 2.5 UPS units of lipase (Test Solution).
- Test Procedure : Test tubes are labeled as S₁, S₂, and S₃ for standards and U for enzyme test. 2.0, 1.5, 1.5, 1.0 mL of phosphate buffer solution (pH 7.5) are added to S₁, S₂, U, and S₃, respectively. 5.0 mL each of trichloro acetic acid solutions added to each test tube, which is labeled as S_{1B}, S_{2B}, S_{3B} and U_B, respectively. Separately, for a blank test, 5 mL of trichloro acetic acid solution and 3mL of phosphate buffer solution (pH 7.5) are mixed in a test tube (labeled as B). All the test tubes (with stirring glass rods)

are isothermalized in a 40°C water bath. 2.0 mL each of substrate solution (isothermalized at 40°C) is added to each test tube at a regular time interval. After 60 minutes, the reaction is stopped by adding 5.0 mL each of trichloro acetic acid solution to S₁, S₂, S₃, and U. All the test tubes are removed from the water bath. They are set aside for 10 minutes at room temperature until proteins are settled down and filtered. Absorption of the completely clear supernatant of each solution is measured at 280 nm with 1 cm path length using blank test solution B as a reference. Absorption values are corrected by respectively subtracting absorptions of S_{1B}, S_{2B}, and S_{3B} filtrates from those of S₁, S₂, and S₃ filtrates. A standard curve is prepared for the corrected absorption of each standard solution vs. its concentration. A concentration of corrected Test Solution (U-U_B) is obtained from corrected standard curve. Enzyme activity of protease is obtained by the following equation.

$$\text{Activity of Protease (USP units/mg)} = \frac{V_A \times C_S}{V_S \times C_A} \times A$$

$$\text{USP Units/mg} = A \times C \times \frac{10}{W}$$

A : Activity of protease of standard material (USP Units/mg)

C : Concentration of standard material corresponding to enzyme Test Solution obtained from the standard curve (mg/mL)

W : Amount of sample in 1.5 mL of Test Solution (mg)

Solutions

- Standard Solution : 100 mg of USP pancreatin standard is precisely weighted and dissolved in phosphate buffer solution (pH 7.5) so that the total volume is 100 mL, which is set aside for 25 minutes at room temperature. This solution is diluted with phosphate buffer solution (pH 7.5) so that 1 mL of the final dilution contains 2.5 USP Units of protease activity (Standard Solution).
- Phosphate Buffer Solution (pH 7.5) : 6.8 g of potassium phosphate monobasic, and 1.8 g of sodium hydroxide are dissolved in 950 mL of water. pH of this solution is adjusted to pH 7.5 ± 0.2 with 0.2 N sodium hydroxide solution. It is then further diluted to 1,000 mL. This solution is stored in a refrigerator.
- Substrate Solution : 1.25 g of casein is well dispersed in 5 mL of water, where 10 mL of 0.1 N sodium hydroxide solution is added. After shaking for 1 minute, 50 mL of water is added and the resulting solution is shaken for approximately 1 hour. pH of this solution is adjusted to 8.0 ± 0.1 using 1 N sodium hydroxide solution or 1 N hydrochloric acid. It is then diluted to 100 mL with water. This solution is freshly prepared before

use.

- Trichloroacetic acid solution : 50 g of trichloroacetic acid dissolve in water to make total volume = 1,000 mL. This solution is stored at room temperature.
- Filter Paper : 5 mL of trichloroacetic acid solution is filtered through a filter paper. Absorption of the filtrate is measured at 280 nm with 1cm path length using unfiltered trichloroacetic acid solution as a reference. The absorption should not be more not more than 0.04. If it is higher, the filter paper is washed with trichloroacetic acid solution until it becomes should not be more than 0.04.

Stotage standard of Pancreatin

Pancreatin should be stored in a hermetic container in a cold dark place.

Pecan Nut Color

Definition Pecan Nut Color is a pigment obtained by extracting outer peel and inner peel of pecans (*Carya Pecan* ENGL. Et GRAEBN.) of Juglandacea with ethyl alcohol. Its major pigment component is flavonoid. Diluent, stabilizer, or solvent can be added for the purpose of color value adjustment and quality preservation.

Compositional Specifications of Pecan Nut Color

Content The color value ($E_{1cm}^{10\%}$) of Pecan Nut Color should be more than the indicated value.

Description Pecan Nut Color is brown liquid or powder with a slight characteristic scent.

Identification (1) An aqueous solution (1→500) of Pecan Nut Color is brown in color.

(2) When the solution in (1) is acidified with 10 mL of hydrochloric acid, brown precipitates are formed.

(3) When ferric chloride solution (1→10) is added to the solution in (1), milky white precipitates are formed.

Purity (1) Arsenic : It should be no more than 4.0 ppm tested by Arsenic Limit Test.

(2) Lead : When 5.0 g of Pecan Nut Color is tested by Atomic Absorption Spectrophotometry or Inductively Coupled Plasma Emission Spectroscopy, its content should not be more than 10.0 ppm.

Assay (Color Value) Appropriate amount of Pecan Nut Color is precisely weighted so that the absorption is within 0.3 ~ 0.7 and dissolved in citric acid buffer solution (pH 7.0) so that the total volume is 100 mL. 1 mL of this solution is diluted to 100 mL with citric acid buffer solution (pH 7.0) (Test Solution). If necessary, the solution is centrifuged and the supernatant is used. Using citric acid buffer solution (pH 7.0) as a reference solution, absorption A is measured at the maximum absorption near 500 nm with 1 cm path length. Color value is obtained using the following equation.

$$\text{Color Value}(\overset{10\%}{E}_{1cm}) = \frac{A \times 1,000}{\text{Weight of the sample(g)}}$$

• Citric acid buffer solution (pH 7.0)

Solution 1 : 1 l of solution containing 21 g of citric acid ($C_6H_8O_7 \cdot H_2O$).

Solution 2 : 1 l of solution containing 71.6 g of dibasic sodium phosphate ($Na_2HPO_4 \cdot 12H_2O$).

Solution 1 and Solution 2 are mixed well (35:165) and its pH is adjusted to 7.0.

Pectin

INS No.: 440

CAS No.: 9000-69-5

Definition

Pectin is a purified polymer of carbohydrates obtained by extracting with boiling water and acid aqueous solution citrus fruits or apple. The essential part of pectin chains consists of α -1, 4 bonding of D-galaturonic acid unit. A portion of carboxyl groups are methyl-esterified and the rest exist as free acid or salts of ammonium, potassium, and sodium. Depending on the usage, sugars can be added to standardize its characteristics or food additives, that are used as buffers to adjust acidity, can be added.

Compositional Specifications of Pectin

Description Pectin is odorless, yellowish white fine or coarse powder with mucus taste.

Identification (1) When 1% aqueous solution is mixed with a same volume of alcohol, transparent gelatinous precipitates are formed (distinguished from other gums).

(2) 1 mL of sodium hydroxide solution is added to 5 mL of 1% aqueous solution of pectin. After allowing to stand for 15 minutes at room temperature, a gel is formed (distinguished from tragacanth or other gums).

(3) The gel obtained in (2) is acidified by 1 mL of hydrochloric acid. When it is well shaken, colorless gelatinous voluminous precipitates are formed. Upon heating, white agglomerates are formed.

Purity (1) Arsenic : It should be no more than 4.0 ppm tested by Arsenic Limit Test.

(2) Lead : When 5.0 g of Pectin is tested by Atomic Absorption Spectrophotometry or Inductively Coupled Plasma Emission Spectroscopy, its content should not be more than 5.0 ppm.

(3) Cadmium : When 5.0 g of Pectin is tested by Atomic Absorption Spectrophotometry or Inductively Coupled Plasma Emission Spectroscopy, its content should not be more than 1.0 ppm.

(4) Mercury : When 0.1 g of Pectin is tested by Mercury Test Method, its content should not be more than 1.0ppm.

(5) Residual solvent : 0.1g of pectin is precisely weighed, 10 mL of diluted internal standard solution(1→25) is added, a stopper is place, and stirred until a homogeneous dispersion is obtained. This solution is filtered by 0.45 μ m filter, and the filtrate is used as test solution. However, tert-butyl alcohol (1→1,000) is used as internal standard solution. Separately, 0.1 g each of methyl alcohol and isopropyl alcohol is precisely measured and water is added to make 100 mL. Again 10 mL of this solution and 4 mL of internal standard solution is weighed, water is added to make 100 mL, mixed standard solution. 2 μ l of test solution and mixed standard solution is taken respectively, and injected to gas chromatograph with the following operation condition. Then, ratio of peak area of methyl

alcohol and isopropyl alcohol peak against tert-butyl alcohol peak, QT1, QT2 and QS1, QS2, is measured respectively, and measure the content of methyl alcohol and isopropyl alcohol under following equation, it should be not more than 1.0% as individual or sum if used together.

$$\text{Content of methyl alcohol (\%)} = \frac{\text{Weight of methyl alcohol(g)}}{\text{Weight of sample(g)}} \times \frac{Q_{T1}}{Q_{S1}}$$

$$\text{Content of isopropyl alcohol (\%)} = \frac{\text{Weight of isopropyl alcohol(g)}}{\text{Weight of sample(g)}} \times \frac{Q_{T2}}{Q_{S2}}$$

Q_{T1} : Ratio of methyl alcohol peak against tert-butyl alcohol peak in Test Solution

Q_{T2} : Ratio of isopropyl alcohol peak against tert-butyl alcohol peak in Test Solution

Q_{S1} : Ratio of methyl alcohol peak against tert-butyl alcohol peak in mixed standard Solution

Q_{S2} : Ratio of isopropyl alcohol peak against tert-butyl alcohol peak in mixed standard Solution

Column : PLOT Q or its equivalent

Detector : Hydrogen Flame Ionization Detector (FID)

Temperature at injection port : 200°C

Column Temperature : 120°C

Detector Temperature : 300°C

Carrier gas : Nitrogen or Helium

(6) Galaturonic acid unit : 5 g of Pectin is precisely weighed into a beaker, 5 mL of hydrochloric acid and 100 mL of 60% ethyl alcohol are added, stirred for 10 minutes, filtered with a glass filter(1G3 or its equivalent). 60% of residue on a glass filter is washed with 15 mL each of 60% mixture of ethyl alcohol: hydrochloric acid(20:1) six times, washed solution is washed with 60% ethyl alcohol until it doesn't react for chloride, and washed with 20 mL of ethyl alcohol again. It is dried for 2.5 hours at 105°C, cooled in a desiccator, and weighed. The amount which corresponds to 1/10 of the weight of the dried substance is precisely weighed. Then the weight is W(mg). To this solution, 2 mL of ethyl alcohol is added and wetted, 100 mL of freshly boiled and cooled water is added, shaken, and mixed. 5 drops of phenolphthalein solution, titrated with 0.1N sodium hydroxide solution, and the consumed amount of the solution is V_1 (mL). 20 mL of 0.5N sodium hydroxide solution is precisely weighed, added, shaken well, mixed, and let stand for 15 minutes. Again, 20 mL of 0.5N hydrochloric acid is precisely weighed, added, titrated with 0.1N sodium hydroxide solution after shaking it well until the red color disappears, and the consumed amount of this solution is V_2 (mL). However, the final point is when the color of solution becomes slightly red after shaking vigorously. Titrated solution is transferred to 500 mL flask for decomposition, which is apparatus of Total Kjeldahl Nitrogen Test (nitrogen determination method). After distilling apparatus is attached, 20 mL of 0.1N hydrochloric acid and 150 mL of freshly boiled

and cooled water are into flask for absorption. Tip of the condenser is submerged in the solution, 20 mL of sodium hydroxide(1→20) is transferred into a flask for decomposition, heated while caring generating bubbles, and 80~120 mL of distillate is obtained. It is titrated with 0.1N sodium hydroxide solution (indicator : Methyl red solution), the consumed amount of the solution is S(mL). Separately, perform the blank test, and the consumed amount of 0.1N sodium hydroxide is B(mL). When measure the content of Galaturonic acid with following equation, it should not be less than 65%.

$$\text{Content of Galaturonic acid(\%)} = \frac{19.41 \times V_1 + V_2 + (B - S)}{W} \times 100$$

(7) Sulfur dioxide : When Pectin is tested by Assay of sulfurous acid, hyposulfurous acid, and salts Test in General Test Method in 「Standards and Specifications for Foods」, its content should not be more than 50ppm.

(8) Acid Insoluble Ash : When 3 g of Pectin proceed as directed under Ash Test, the content should not be more than 1.0%.

Loss on Drying When 3 g of Pectin is dried for 2 hours at 105°C, the weight loss should not be more than 12%.

Pectinase

Definition Pectinase is an enzyme obtained from cultures of *Aspergillus niger*, cultures of *Aspergillus oryzae* where pectinase gene of *Aspergillus aculeatus* is inserted and cultures of *Aspergillus aculeatus* to decompose pectin and pectin acid. Polygalacturonase, pectinesterase, and pectin lyase are included. Dilutant or stabilizer can be added for the purpose of activity adjustment and quality preservation.

Compositional Specifications of Pectinase

Description Pectinase is white ~ dark brown powder, particle, paste or colorless ~ dark brown liquid.

Identification When Pectinase is proceeded as directed under Activity Test, it should have the activity as Pectinase.

Purity (1) Lead : Accurately weigh 2 g of Pectinase and place it in a platinum or quartz crucible. Add minute amount of sulfuric acid, wet, gradually heat and preliminarily heat-treated at the temperature as low as possible. Again add 1 mL of sulfuric acid, gradually heat, ignite until it is heat-treated at 450 ~ 550°C. After heat-treating, add minute amount of nitric acid(1→150) to the residue, again, add nitric acid(1→150) to make 10 mL, test solution. Separately, weigh 1 mL of lead standard solution, add nitric acid(1→150) to make 10 mL, reference solution. When test solution and reference solution are tested by flame Atomic Absorption Spectrophotometry under following operation condition, the absorbance of test solution should not be higher than that of reference solution (not more than 5.0 ppm).

(2) Coliform Group : When Pectinase proceed as directed under Microbe Test Methods for Coliform Group in General Test Methods 「Standards and Specifications for Foods」 it should not contain more than 30 cfu per 1 g of this product.

(3) Salmonella : When Pectinase proceed as directed under Microbe Test Methods for Salmonella in General Test Methods 「Standards and Specifications for Foods」 it should be negative (-).

(4) E. Coli : When 25 g of Pectinase is tested by Microbe Test Methods for E. Coli in General Test Method 「Standards and Specifications for Foods」, it should be negative (-).

Activity Test (activity) Each of method 1, 2, and 3 is applied to polygalacturonase, pectinesterase, and pectin lyase, respectively.

Method 1

Principle : This test is to measure the amount of reducing sugar of Galacturonic acid generated by hydrolysis of pectic acid at pH 4.0, temperature 40°C.

Preparation of Test Solution : Test Solution is prepared by dilution a certain amount of sample with citric acid buffer solution (pH 4.0) so that 1 mL contains 40~60 Pectinase units.

Test Procedure : 10 mL of substrate solution is maintained in a 100 mL Erlenmeyer flask in a water bath for 5 minutes at 40°C. 1 mL of Test Solution is added to the substrate solution, which is immediately

shaken and mixed, allowed to stand for exactly 30 minutes at 40°C, 3mL of anhydrous sodium carbonate solution(106→1,000) is added, and reaction is stopped. 6 mL of 0.1 N iodine solution is added, which is then shaken, mixed, and allowed to stand for 30 minutes in a dark place. After adding 6 mL of 8 N sulfuric acid and the solution is quickly titrated with 0.02 N sodium thiosulfate solution until the color of iodine almost disappear. Again 1 mL of starch solution is added, 0.02 N sodium thiosulfate solution is drop-wise added, titrated until the blue color disappear(AmL). Separately, a blank test is carried out with 3 mL of anhydrous sodium carbonate solution(106→1,000) is transferred into a 100 mL erlenmeyer flask and 1 mL of test solution is added, shaken, and mixed. 10 mL of substrate solution is added, 6 mL of 0.1N iodine solution is added, shaken, mixed, allowed to stand for 30 minutes in a dark place, and titrated same as test solution. (BmL).

The enzyme activity is obtained by the following equation.

$$U/g = (B-A) \times 513 \times \frac{2}{100} \times \frac{60}{30} \times \frac{1}{W}$$

513 : Amount of 1mmol iodine corresponding to 513μmol of galacturonic acid

W : Weight of sample contained in 1 mL Test Solution (g)

Definition of Activity : 1 Polygalacturonase unit corresponds to an amount of enzyme that generates 1 μmol of galacturonic acid for 1 hour under the above conditions.

Solutions

- Substrate Solutions : 1.0g of pectic acids(Sigma P3889 or its equivalent) is precisely weighed, dried for 3 hours at 105°C, and measure the weight loss. Pectic acid corresponding to 0.55 g of anhydrous is precisely weighed, dissolved in 80 mL of citric acid buffer solution(pH 4.0). After dissolving, pH is adjusted to 4.0 with trisodium citrate solution(29.4→100) or hydrochloric acid(9→100), citric acid buffer solution(pH 4.0) is added to make 100mL.
- Citric acid Buffer Solution (pH 4.0)
 - Solution A : 0.1N Hydrochloric acid
 - Solution B : 14.7 g of trisodium citrate is dissolved, and make to 1,000 mL with water.
 - pH of Solution B is adjusted to 4.0 with using solution A.

Method 2

Principle : This test is to measure the initial reaction rate from alkali consumption rate by titrating with alkali, which is generated by liberating of ester group in pectic acid at pH 4.8, temperature 30°C.

Preparation of Test Solution : Test Solution is prepared by dilution a certain amount of sample with water

so that 1 mL contains 0.0007 ~ 0.006 unit.

Test Procedure : 20 mL of substrate solution is precisely weighed into a beaker, and maintained in water bath at 30°C. 0.05N of sodium hydroxide solution is added to substrate solution to bring pH 4.8, and 1 mL of test solution is added. While adjusting to pH 4.8 for 2 minutes, observe the reaction, and the consumed amount (mL) of 0.05N sodium hydroxide solution is A. Separately, for a blank test, 0.05N of sodium hydroxide solution is added to substrate solution to bring pH 4.8, and 1 mL of water is added. While adjusting to pH 4.8 for 2 minutes, the consumed amount (mL) of 0.05N sodium hydroxide solution is B. The enzyme activity is obtained by the following equation.

$$U/g = \frac{A-B}{20 \times 2 \times W}$$

20 : Titrated amount(μ l) of 0.05N sodium hydroxide corresponding to 1 μ mol carboxyl group

2 : Reaction time (minute)

W : Weight of sample contained 1 mL of test solution (g)

Definition of Activity : 1 Pectinesterase unit is an amount of enzyme that liberates 1 μ mol of carboxyl group from pectin for 1 minutes under the above conditions.

Solutions

Substrate Solutions : 5 g of Esterification pectinFluka 76282(pectin from apple, not less than 70% methoxylated) or equivalent is precisely weighed, gently mixed with 800 mL of water maintained to 40°C, and suspended. It is dissolved thoroughly at the temperature not more than 60°C and cooled to room temperature. To this, 2.03g of magnesium chloride is added, pH is adjusted to 4.8 with sodium hydroxide solution, water is added to make 1,000 mL.

Method 3

Principle : This test is to measure the amount of unsaturated Galacturonic acid, which is generated from decomposition of pectin at pH 5.8, temperature 30°C, by absorbance.

Preparation of Test Solution : 0.5 g of Pectinase is dissolved in citric acid buffer solution(pH 5.8) to make 100 mL, 3 mL of this solution is diluted with citric acid buffer solution(pH 5.8) to make 25 mL, test solution.

Test Procedure: To 3 mL of substrate solution is maintained in a water bath at 30°C for 5 minutes, 0.1 mL of test Solution is added and shortly shaken. Using water as a reference solution, absorbance curve per minute of the test solution is prepared by measuring absorbance every 1 minute, for 10 minutes, at 235 nm with 1cm cell. Repeat the same procedure three times. Linear section should be maintained at least for 5 minutes (6 points). The change of absorbance should not be more than 0.03 per minute,

the range of 0.02 ~ 0.03 is optimum.

The enzyme activity is obtained by the following equation.

$$U/mg = \frac{\Delta A_{235}/\Delta t}{0.01 \times 3.1 \times C}$$

3.1 : Final reaction solution (mL)

C : Concentration of final test solution (mg/mL)

Definition of Activity : 1 Pectin lyase unit is the amount of enzyme increasing absorbance 0.01 per minute under the above conditions.

Solutions

Substrate Solutions : 0.5 g of Pectin(Copenhagen Pectin X 2955, Sigma P9135 or its equivalent) is transferred into a beaker, stirred with 2 mL of ethanol, 80 mL of citric acid buffer solution(pH 5.8) is added with using magnetic stick, and stirred while caring bubbles are not generated. pH of the solution is adjusted to 5.8 with using solution A or solution B, and make 100mL with citric acid buffer solution(pH 5.8). This solution is allowed to settle in refrigerator for 1 night, next day, centrifuged for 10 minutes at 12,000×g, filtered, and used.

Citric acid buffer solution(pH 5.8)

Solution A : 35.6g of Disodium hydrogen phosphate (2 hydrates) is dissolved with water, and make to 1,000 mL.

Solution B : 21g of citric acid (1hydrate) is dissolved with water, and make to 1,000 mL.

57mL of Solution A and 43mL of Solution B are mixed well, and adjust to pH 5.8 with Solution A or Solution B.

Storage Standard of Pectinase

Pectinase is strongly hygroscopic, so should be stored in a cold dark place with sealing tightly.

Pepsin

Definition Pepsin is an enzyme obtained from extracts of the stomach and intestines of pigs or other animals. Dilutant or stabilizer can be added for the purpose of activity adjustment and quality preservation.

Compositional Specifications of Pepsin

Description Pepsin is white ~ deep brown powder, granule, paste or colorless~deep brown liquid.

Identification When Pepsin is proceeded as directed under Activity Test, it should have the activity as Pepsin.

Purity (1) Arsenic : It should be no more than 4.0 ppm tested by Arsenic Limit Test.

(2) Lead : When 5.0 g of Pepsin is tested by Atomic Absorption Spectrophotometry or Inductively Coupled Plasma Emission Spectroscopy, its content should not be more than 5.0 ppm.

(3) Coliform Group : When Pepsin proceed as directed under Microbe Test Methods for Coliform Group in General Test Methods in Food Code, it should not contain more than 30 per 1 g of this product.

(4) Salmonella : When Pepsin proceed as directed under Microbe Test Methods for Salmonella in General Test Methods in Food Code, it should be negative (-).

(5) E. Coli : When Pepsin is tested by Microbe Test Methods for E. Coli in General Test Method 「Standards and Specifications for Foods」, it should be negative (-).

Activity Test (activity)

◦Preparation of Test Solution : 100 mg of the sample or a certain amount of enzyme that contains activity slightly higher than or similar to the Standard Solution is dissolved in 150 mL of hydrochloric acid solution. This solution should be used within 1 hour after preparation.

◦Test Procedure : 5.0 mL each of Standard Solution is placed in two bottles containing substrate solution. In two or more bottles, Test Solution is added so that one bottle contains the same amount of pepsin as 5.0 mL of Standard Solution and other bottles contain decrementally smaller amount of pepsin (for example, 5.0 mL, 4.9 mL, and 4.8 mL, etc.). When the amount of Test Solution should be not more than 5.0 mL, the difference is supplemented with hydrochloric acid solution. The bottles are capped and shaken upside down three times. The bottles are maintained in a water bath at $52 \pm 0.5^{\circ}\text{C}$ for 2 hours and 30 minutes, agitating the contents equally every 10 minutes by inverting the bottles once. Remove the bottles from the bath, the contents in the bottles are transferred into each test container. Undigested albumin attached on the inner walls of the bottles are washed with 50 mL of water and added to the test containers. The contents in the container are well mixed and allowed to stand for 30 minutes. The volume of undigested albumin is measured. The average volume of the precipitates in the two standard containers is obtained. The volume of the residues from the Test Solution, that is closest to this average value, is marked as V (mL).

The enzyme activity is calculated by the following equation.

$$\text{Pepsin units/mg} = 3,000 \times \frac{S}{U} \times \frac{5.0}{V}$$

S : Weight of pepsin used in Standard Solution (mg)

U : Weight of sample(mg)

V : volume of the residues in Test Solution

Definition of Activity : 1 Pepsin unit corresponds to an amount of enzyme that digests the coagulated egg albumin that is 3,000 times the weight of enzyme under the above conditions.

Apparatus

Test Container : 100 mL conical container, that fits the following criteria, is used.

- (1) Diameter for the bottom part should not be more than 1 cm.
- (2) Appropriate for water and precipitate tube in ASTM standard method D 96-68.
- (3) There should be 0.05 mL scale marks in a range of 0~0.5 mL, 0.1 mL scale marks in a range of 2~3 mL, 0.2 mL scale marks in a range of 3~5 mL, 1 mL scale marks in a range of 5~10mL, 5 mL scale marks in a range of 10~25 mL, and scale marks at 50 mL, 75 mL, and 100 mL. (note : Any container with similar shape and scale marks can be used provided that the volume of residues can be measured with similar accuracy.)

Solutions

- Hydrochloric Acid Solution : 35 mL of 1 N hydrochloric acid is mixed with 385 mL of water.
- Substrate : 1 ~ 2 eggs are boiled for 15 minutes and rapidly cooled in cold water. Shells and yolks of the eggs are removed completely. Egg whites are sieved through No.40 mesh screen. First portion that passes through the sieve is discarded.
- Substrate Solution : 10.0 g of substrate is placed in a 100 mL wide mouth bottle (as many as needed for the test), where 35 mL of hydrochloric acid solution is added immediately. Egg white grains are finely ground by an appropriate method. It is isothermalized at 52°C before testing.
- Standard Solution : 100.0 mg of pepsin standard is precisely weighed and dissolved in 150 mL of hydrochloric acid solution. This solution is used within 1 hour after preparation.

Storage Standard of Pepsin

Pepsin is strongly hygroscopic, so should be stored in a cold dark place with sealing tightly.

Perilla Color

Definition Perilla Color is a pigment obtained by extracting leaves of perilla (*Perilla frutescens* BRITT. Var. *acuta* KUDO.) of labiatae with ethyl alcohol. Its major pigment component is shisonin, malonyl shisonin. Dilutant, stabilizer, or solvent can be added for the purpose of color value adjustment and quality preservation.

Compositional Specifications of Perilla Color

Content Color value ($E_{1cm}^{10\%}$) of Perilla Color should be more than the indicated value.

Description Perilla Color is dark red liquid, paste, powder, or paste with a slight characteristic scent.

Identification (1) A solution (1→100) of Perilla Color in citrate buffer solution (pH 3.0) is red color and has a maximum absorption band near 520 nm.

(2) When the solution in (1) is alkalinized with sodium hydroxide solution (1→25), its color changes to dark red.

Purity (1) Arsenic : It should be no more than 4.0 ppm tested by Arsenic Limit Test.

(2) Lead : When 5.0 g of Perilla Color is tested by Atomic Absorption Spectrophotometry or Inductively Coupled Plasma Emission Spectroscopy, its content should not be more than 10.0 ppm.

Assay (Color Value) Appropriate amount of Perilla Color is precisely weighted so that the absorption is within 0.3 ~ 0.7 and dissolved in citrate buffer solution (pH 3.0) so that the total volume is 100 mL (Test Solution). If necessary, the solution is centrifuged and the supernatant is used. Using citrate buffer solution (pH 3.0) as a reference solution, absorption A is measured at the maximum absorption near 520 nm with 1cm path length. Color value is obtained using the following equation.

$$\text{Color Value } (E_{1cm}^{10\%}) = \frac{A \times 10}{\text{Weight of the sample(g)}}$$

◦ Citrate buffer solution (pH 3.0)

Solution 1 : 1 l of solution containing 121g of citric acid ($C_6H_8O_7 \cdot H_2O$).

Solution 2 : 1 l of solution containing 71.6g of dibasic sodium phosphate ($Na_2HPO_4 \cdot 12H_2O$).

Solution 1 and Solution 2 are mixed well (159 : 41) and its pH is adjusted to 3.0.

Perlite

Synonyms: Expanded perlite

CAS No.: 130885-09-5

Definition Perlite is prepared by calcining mineral silicon dioxide at 800~1,200°C.

Compositional Specifications of Perlite

Description Perlite is white or light gray powder.

Identification Proceed as directed under in Identification (1) for Diatomaceous Earth.

Purity (1) Water Solubles and pH : When Perlite proceed as directed under Purity (1) in Diatomaceous Aarth, pH should be 5.0~9.0, and the residues should not be more than 10 mg.

(2) Hydrochloric Acid Solubles : When Perlite proceed as directed under Purity in Diatomaceous Aarth, the content should not be more than 15 mg.

(3) Arsenic : It should be no more than 4.0 ppm tested by Arsenic Limit Test.

(4) Lead : Proceed as directed under Purity (5) in Diatomaceous Earth and the content should not be more than 10.0 ppm.

Hydrofluoric Acid Residue When Perlite proceed as directed under Hydrofluoric Acid Residue in Diatomaceous Aarth, the content should not be more than 75 mg.

Loss on Ignition When Loss on Ignition is done at 1,000°C for 30 minutes, weight loss should not be more than 3%.

Peroxyacetic Acid

Chemical Formula: $C_2H_4O_3$

Molecular Weight: 76.05

CAS No.: 79-21-0

Definition Peroxyacetic acid is obtained by reacting both hydrogen peroxide and acetic acid which contains peroxyacetic acid, hydrogen peroxide and acetic acid as active ingredient, or by reacting peroxyacetic acid, acetic acid and caprylic acid(synonym : octanoic acid) which contains peroxyacetic acid, peroxyoctanoic acid, hydrogen peroxide, caprylic acid and acetic acid. However, 1-hydroxytiliden-1,1-diphosphonic acid is able to added for dilution or quality stability, etc.

Compositional Specifications of Peroxyacetic Acid

Content Peroxyacetic acid contains 5~18% of peroxyacetic acid($C_2H_4O_3$), 15~60% of acetic acid($C_2H_4O_2$), 4~25% of hydrogen peroxide(H_2O_2), not more than 1.0% of 1-hydroxytiliden-1,1-diphosphonic acid, and not more than 10% of caprylic acid.

Description Peroxyacetic acid is a colorless, clear liquid. It has a peculiar stimulating odor.

Assay (1) peroxyacetic acid and acetic acid: Weigh approximate 1 g of peroxyacetic acid precisely, and add to 100 mL water, and use it as a test solution. Inject 5 mL of methanol to an Octadexylized silica gel mini-column(500mg), then pour 10mL of water, and discard the spill. To this column, inject 10 mL of the test solution and take the spill out into the 100 mL beaker. Then, pour 10mL of water and add the spillage to the same beaker, add about 30 mL of water, and titrate it with a 0.1 mol/L sodium hydroxide solution using a potentiometer. Use a glass electrode for the telltale and an AgCl electrode for the reference electrode. Obtain the consumption a(mL) and b(mL) of a 0.1mol/L sodium hydroxide solution at the 1st and 2nd inflection points, and calculate the content of peroxyacetic acid and acetic acid according to the following formula.

$$\text{Content of Peroxyacetic acid}(C_2H_4O_3)(\%) = \frac{(b-a) \times 0.1 \times 76.05}{\text{Sample (g)}}$$

$$\text{Content of Acetic acid}(C_2H_4O_2)(\%) = \frac{a \times 0.1 \times 60.05}{\text{Sample(g)}}$$

Column

Octadexylized silica gel mini-column(500 mg): This column is filled with 0.5 g of octadexylized silica gel in a polyethylene tube that is 10~25 mm diameter, or a column that has an equivalent separation characteristic.

(2) Hydrogen peroxide: Weigh approximate 1 g of hydrogen peroxide and add water to make 100 mL. Take exact 10 mL of this solution and put it into a 250 mL triangle flask, and add 75 mL of 0.5 mol/L sulfuric acid, which is cooled down, to use as test solution. Add 2 drops of ferriin solution to this test solution and titrate it with 0.1 mol/L cesium sulfate(IV) solution. The end point of titration is the moment when the orange color changes to a colorless color after a light red color. Amount of hydrogen peroxide is calculated by the following formula.

$$\text{Content (\%)} = \frac{\text{Consumption of 0.1 mol/L cesium sulfate(IV)} \times 0.1 \text{ mol/L} \times 0.1 \times 17.00}{\text{Sample(g)}}$$

Test solution

Ferriin solution : Dissolve 0.7 g of ferrous sulfate(seven hydrate) and 1.78 g of o-phenanthroline(one hydrate) in water to make 100 mL.

(3) Caprylic acid : Weigh approximate 0.7 g of caprylic acid and add mixture of water/acetonitrile(1:1) to make exact 50 mL. Take 5 mL of this solution, and add mixture of water/acetonitrile(1:1) to make exact 20 mL to use it as a test solution. Weigh approximate 0.2 g of caprylic acid for quantitative and add mixture of water/acetonitrile(1:1) to make exact 100 mL for use it as a standard solution. Take exact 0.5 mL, 1mL 2.5 mL, 5 mL and 10 mL of the standard solution and add mixture of water/acetonitrile(1:1) to make exact 20 mL as standard solution. Use 20 μ L of each standard solutions and 20 μ L of the test solution for the Liquid Chromatography analysis. Draw a calibration curve by the peak area of caprylic acid from each standard solutions. Substitute the peak area of caprylic acid from the test solution to the calibration curve, and calculate the concentration(μ g/mL) of caprylic acid. Amount of caprylic acid is calculated by the following formula.

$$\text{Content(\%)} = \frac{\text{Concentration of Caprylic acid in the test solution}(\mu\text{g/mL})}{\text{Sample(g)} \times 50}$$

Operating Conditions

Detector : Ultraviolet absorption spectrometer(210 nm wave)

Packing materials : 5 μ m of octadecylsized silica gel for Liquid Chromatography

Column tube : 4.6mm internal diameter, 25 cm length of stainless tube

Column temperature : 30 $^{\circ}$ C

mobile phase : Dissolve 0.12 g of acetic acid in 350 mL of water, and add 650 mL of acetonitrile

flow rate : 1.0 mL/min.

Persimmon Color

Definition Persimmon Color is obtained by fermenting and heat treating fruits of persimmon of persimmon family (*Diospyros kaki* THUNB.). Major colorant is flavonoid. Dilutant, stabilizer, or solvent can be added for the purpose of color value adjustment and quality preservation.

Compositional Specifications of Persimmon Color

Content Color value ($E_{1\text{cm}}^{10\%}$) of Persimmon Color should be higher than that is indicated value.

Description Persimmon Color is reddish brown ~ blackish brown liquid, lump, powder, or paste with a slight characteristic scent.

Identification (1) Test Solution obtained in Color Value for Persimmon Color becomes reddish brown.

(2) Take 0.5 g of the sample, into 100 mL volumetric flask, add water to volume. When 10 mL of this solution is acidified with 1 mL of hydrochloric acid, reddish brown ~ blackish brown precipitates are formed.

(3) Water is added to 0.5 g of Persimmon Color so that the total volume is 100 mL. When 2 mL of 2% ferric chloride solution(1→10) is added to 10 mL of this solution, blackish brown precipitates are formed.

Purity (1) Arsenic : It should be no more than 4.0 ppm tested by Arsenic Limit Test.

(2) Lead : When 5.0 g of Persimmon Color is tested by Atomic Absorption Spectrophotometry or Inductively Coupled Plasma Emission Spectroscopy, its content should not be more than 10.0 ppm.

Assay(Color value) Appropriate amount of Persimmon Color is weighed so that the absorbance to be measured will within a range of 0.3 ~ 0.7. Citric acid-dibasic sodium phosphate buffer solution with pH 7.0 is added so that the total volume is 100 mL, and this is used as the Test Solution. If necessary, the solution is centrifuged and the supernatant is used. Using citric acid-dibasic sodium phosphate buffer solution with pH 7.0 as a reference solution, absorption A is measured at 500 nm wavelength with 1cm path length. Color value is obtained using the following equation.

$$\text{Color Value}(E_{1\text{cm}}^{10\%}) = \frac{A \times 10}{\text{weight of the sample(g)}}$$

Citric acid-dibasic sodium phosphate buffer solution (pH 7.0)

•Solution 1 : 0.1 M citric acid solution : 1 L of solution containing 21.01g of citric acid ($\text{C}_6\text{H}_8\text{O}_7 \cdot \text{H}_2\text{O}$).

•Solution 2 : 0.2 M dibasic sodium phosphate solution : 1 L of solution containing 71.63 g of dibasic sodium phosphate ($\text{Na}_2\text{HPO}_4 \cdot 12\text{H}_2\text{O}$).

Solution 1 and Solution 2 are mixed well (35:165) and its pH is adjusted to 7.0.

Petroleum Wax

Refined Paraffin Wax : Microcrystalline Wax

INS No.: 905c(i), 905c(ii)

Synonyms: Refined paraffin wax; Microcrystalline
wax

CAS No.: 63231-60-7

Definition Petroleum Wax is prepared by removing with propanol lake, lead, and oil from vacuum distillation residue oil of crude oil, in the cold. Or it can be prepared by treating with furfural, in the hot, and followed by removal of furfural. It consists of branched hydrocarbons ($C_{30} \sim C_{60}$).

Compositional Specifications of Petroleum Wax

Description Petroleum Wax is translucent, tasteless, and odorless wax.

Identification Infrared spectra of Petroleum Wax (observed by IR spectrophotometry) shows the following pattern. Petroleum Wax is melted and determined using potassium bromide plate.

(1) Purified Petroleum Wax

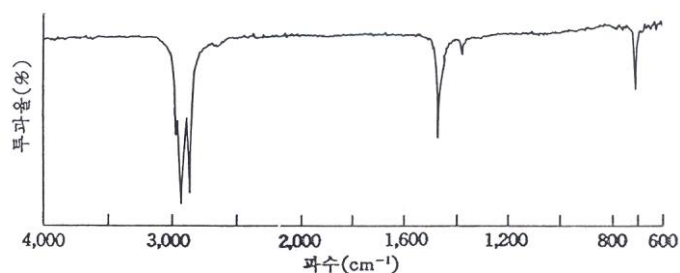

(2) Microcrystalline Wax

Purity (1) Arsenic : It should be no more than 2.0 ppm tested by Arsenic Limit Test.

(2) Lead : When 5.0 g of Petroleum Wax is tested by Atomic Absorption Spectrophotometry or Inductively Coupled Plasma Emission Spectroscopy, its content should not be more than 3.0 ppm.

(3) Melting Point : When Petroleum Wax determined it by melting point method, it should be within the indicated range (48~93°C).

Residue on Ignition When Residue on Ignition is done with a Petroleum Wax, the amount of residue should not be more than 0.1%.

Phaffia Color

Definition Phaffia Color is a pigment obtained by extracting the cultures of an enzyme (Phaffia rhodozyma MILLER) with ethyl alcohol. Its major pigment component is Astaxanthin of carotenoids. Diluent, stabilizer, or solvent can be added for the purpose of color value adjustment and quality preservation.

Compositional Specifications of Phaffia Color

Content Color value ($E_{1cm}^{10\%}$) of Phaffia Color should be more than the indicated value.

Description Phaffia Color is reddish brown ~ brown with a slight characteristic scent.

Identification A solution of Phaffia Color in petroleum ether (1→500) is orange in color and has a maximum absorption band near 474 nm.

Purity (1) Arsenic : It should be no more than 4.0 ppm tested by Arsenic Limit Test.

(2) Lead : When 5.0 g of Phaffia Color is tested by Atomic Absorption Spectrophotometry or Inductively Coupled Plasma Emission Spectroscopy, its content should not be more than 10.0 ppm.

(3) Residual Solvents : When Phaffia Color is tested by Purity (5) for Paprika Extract Pigments, the content of residual solvents should be,

Acetone Not more than 30ppm

Hexane Not more than 25ppm

Assay(Color Value) An appropriate amount of Phaffia Color is precisely weighted and mixed with 10mL of Dimethylsulfoxide (pre-heated to 55°C) so that the measured absorption lies within a range of 0.3 ~ 0.7. It is then reacted for 8 minutes in a 55°C water bath. To this reaction mixture, 3 mL of phosphate buffer solution (pH 7.0) and 30 mL of petroleum ether are added. It is well mixed and set aside to separate phases. Petroleum ether phase is collected. The lower aqueous phase is extracted twice with 30 mL each of petroleum ether, which is added to the previous petroleum ether phase. The total volume is brought up to 100 mL with petroleum ether (Test Solution). If necessary, the supernatant is centrifuged for use. Color value is obtained using the following equation. Using petroleum ether as a reference, absorption A of the Test Solution is measured at a maximum absorption band near 474 nm with 1cm path length. Color value is obtained by the following equation.

$$\text{Color value}(E_{1cm}^{10\%}) = \frac{A \times 10}{\text{Weight of the sample(g)}}$$

• Phosphate Buffer Solution (pH 7.0)

Solution 1 : 53.7 g of sodium phosphate, dibasic ($\text{Na}_2\text{HPO}_4 \cdot 12\text{H}_2\text{O}$) dissolve in water (total volume = 1,000 mL).

Solution 2 : 20.4 g of potassium phosphate, monobasic(KH_2PO_4) dissolve in water(total volume = 1,000 mL).

Solutions 1 & 2 are well mixed in a volume ratio of 80 : 45 and the pH is adjusted to 7.0.

DL-Phenylalanine

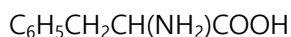

Chemical Formula: $\text{C}_9\text{H}_{11}\text{NO}_2$

Molecular Weight: 165.19

Synonyms: DL- α -Amino- β -phenylpropionic acid

CAS No.: 150-30-1

Compositional Specifications of DL-Phenylalanine

Content DL-Phenylalanin, when calculated on the dried basis, should contain within a range of 98.5~101.5% of DL-Phenylalanine ($\text{C}_9\text{H}_{11}\text{NO}_2$).

Description DL-Phenylalanin is white crystalline platelet. It is odorless.

Identification (1) To 5 mL of DL-Phenylalanin solution (1 \rightarrow 1,000), add 1 mL of ninhydrine standard solution and heat it. This solution becomes violet.

(2) To 5 mL of DL-Phenylalanin solution (1 \rightarrow 1,000), add a few drops of potassium bichromate solution and heat. Then a characteristic scent is generated.

(3) To 10 mg of DL-Phenylalanin, add 0.5 g of potassium nitrate and 2 mL of sulfuric acid, and heat for 20 minutes in a water bath. After cooling, 2 mL of hydroxylamine solution is added and the solution is kept for 10 minutes in an ice bath. 10 mL of sodium hydroxide solution is added immediately and the solution is set-aside. The solution becomes violet.

Purity (1) Lead : When 5.0 g of DL-Phenylalanine is tested by Atomic Absorption Spectrophotometry or Inductively Coupled Plasma Emission Spectroscopy, its content should not be more than 5.0 ppm.

Loss on Drying When DL-Phenylalanin is dried for 2 hours at 105°C, the weight loss should not be more than 0.2%.

Residue on Ignition When thermogravimetric analysis is done with 1 g of DL-Phenylalanin, the amount of residue should not be more than 0.3%.

Assay Approximately 0.5 g of DL-Phenylalanin, previously dried for 2 hours at 105°C, is precisely weighed, is dissolved in 70 mL of formic acid (for non-aqueous titration). This solution is titrated with 0.1 N perchloric acid solution (indicator : 2 drops of crystal violet buffered in glacial acetic acid). At the end point, the solution becomes from violet to blue, then to green. Separately, a blank test is carried out by the same procedure.

$$1 \text{ mL of } 0.1 \text{ N perchloric acid solution} = 16.52 \text{ mg } \text{C}_9\text{H}_{11}\text{NO}_2$$

L-Phenylalanine

Chemical Formula: $C_9H_{11}O_2N$

Molecular Weight: 165.19

Synonyms: L- α -Amino- β -phenylpropionic acid

CAS No.: 63-91-2

Compositional Specifications of L-Phenylalanine

Content L-Phenylalanine, when calculated on the dried basis, should contain within a range of 98.5 ~ 102.0% of L-phenylalanine ($C_9H_{11}O_2N$).

Description L-Phenylalanine occurs as white crystals or crystalline powder and has a slightly bitter taste.

Identification (1) To 5 mL of L-Phenylalanine solution (1→1000), add 1 mL of potassium dichromate solution (1→1000). Upon heating the solution, characteristic scent is generated.

(2) To 5 mL of L-Phenylalanine solution (1→1,000), add 1 mL of ninhydrin solution (1→1,000), and heat for 3 minutes. A red-purple to blue-purple color becomes.

(3) To 10 mg of L-Phenylalanine, add 0.5 g of potassium nitrate and 2 mL of sulfuric acid, heat in a water bath for 20 minutes. After cooling, add 5 mL of hydroxylamine hydrochloride solution (1→10), set aside in ice water for 10 minutes. Add 8 mL of 40% sodium hydroxide solution, and set aside. A red-purple color becomes.

Purity (1) Clarity and Color of Solution : When 1 g of L-Phenylalanine is dissolved in 100 mL of water, the solution should be colorless and almost clear.

(2) pH : pH of L-Phenylalanine solution (1→100) should be within a range of 5.4~6.0.

(3) Specific Rotation : Approximately 1 g of L-Phenylalanine, previously dried for 3 hours at 105°C and precisely weighed, is dissolved in 50 mL of water. Optical rotation of this solution should be within a range of $[\alpha]_D^{20} = -33.0 \sim -35.2^\circ$.

(4) Arsenic : It should be no more than 4.0 ppm tested by Arsenic Limit Test.

(5) Lead : When 5.0 g of L-Phenylalanine is tested by Atomic Absorption Spectrophotometry or Inductively Coupled Plasma Emission Spectroscopy, its content should not be more than 5.0 ppm.

(6) Chloride : When 0.5 g of L-Phenylalanine is proceeded as directed under chloride, its content should not be more than the amount that corresponds to 0.3 mL of 0.01 N hydrochloric acid.

Loss on Drying When L-Phenylalanine is dried for 3 hours at 105°C, the weight loss should not be more than 0.3%.

Residue on Ignition When thermogravimetric analysis is done with L-Phenylalanine, the residue should not

be more than 0.1%.

Assay 0.3 g of L-Phenylalanine, previously dried and accurately weighed, is proceeded as directed under Assay in 「Glycine」.

1 mL of 0.1 N perchloric acid = 16.52 mg of $C_9H_{11}O_2N$

Phenylethyl Acetate

Phenylethyl Acetate

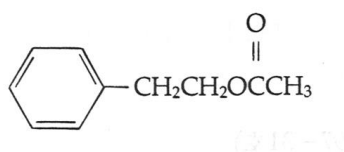

Chemical Formula: C₁₀H₁₂O₂

Molecular Weight: 164.20

Synonyms: 2-Phenylethyl acetate; Benzyl carbinyl acetate

CAS No.: 103-45-7

Compositional Specifications of Phenethyl Acetate

Content Phenylethyl Acetate should contain not less than 98.0% of Phenylethyl acetate (C₁₀H₁₂O₂).

Description Phenylethyl Acetate is a colorless, transparent liquid having a characteristic odor.

Identification To 1 mL of Phenylethyl Acetate, add 5 mL of 10% alcoholic solution of potassium hydroxide, equip with a reflux condenser, and heat in a water bath for 20 minutes. The characteristic odor disappears. Cool, and add 8 mL of water and 1 mL of diluted hydrochloric acid. The solution responds to the test for Acetate (C) in Identification.

Purity (1) Specific Gravity : Specific gravity of Phenylethyl Acetate should be within a range of 1.030 ~ 1.034.

(2) Refractive Index : Refractive Index n_D^{20} of Phenylethyl Acetate should be within a range of 1.497 ~ 1.501.

(3) Clarity and Color of Solution : When 1 mL of Phenylethyl Acetate is dissolved in 2 mL of 70% alcohol, the solution should be clear.

(4) Acid Value : Acid value of Phenylethyl Acetate is tested by Acid Value in Flavoring Substance Test. It should not be more than 1.

Assay Accurately weigh about 1 g of Phenylethyl Acetate, and proceed as directed under Ester Value and Ester Content in Flavoring Substances Tests.

1 mL of 0.5 N alcoholic solution of potassium hydroxide = 82.10 mg of C₁₀H₁₂O₂

Phosphodiesterase

Definition Phosphodiesterase is an enzyme obtained from cultures of *Penicillium citrinum*. Dilutant or stabilizer can be added for the purpose of activity adjustment and quality preservation.

Compositional Specifications of Phosphodiesterase

Description Phosphodiesterase is white ~ dark brown powder, granular, pasty substances or colorless ~ dark brown liquid.

Identification When Phosphodiesterase is proceeded as directed under Activity Test, it should have the activity as Phosphodiesterase.

Purity (1) Arsenic : It should be no more than 4.0 ppm tested by Arsenic Limit Test.

(2) Lead : When 5.0 g of Phosphodiesterase is tested by Atomic Absorption Spectrophotometry or Inductively Coupled Plasma Emission Spectroscopy, its content should not be more than 5.0 ppm.

(3) Coliform Group : Phosphodiesterase proceed as directed under Microbe Test Methods in Coliform Group in General Test Methods in 「Standards and Specifications for Foods」. It should contain not more than 30 colonies per 1 g of this product.

(4) Salmonella : When Phosphodiesterase is tested by Microbe Test Methods for Salmonella in General Test Method 「Standards and Specifications for Foods」, it should be negative (-).

(5) E. Coli : When 25 g of Phosphodiesterase is tested by Microbe Test Methods for E. Coli in General Test Method 「Standards and Specifications for Foods」, it should be negative (-).

Activity Test (activity)

Analysis principle : Adenosine 3'-monophosphate sodium salt substrate by treating with Phosphodiesterase produce phosphoric acid Change it to phosphomolybdic acid under acidic condition of perchloric acid. Reduce it with amidol solution and it produces molybdenum blue. Activity test is based on colorimetry of the blue color of molybdenum blue.

Preparation of Test Solution : When Phosphodiesterase is weighted, use water so that 1 mL of the final diluent solution contains 0.09~0.43 Phosphodiesterase unit.

Preparation of standard curve : Weigh 0.142 g of disodium hydrogen phosphate(anhydrous form) and make to volume to 100 mL(10 μ mol/mL). Take precisely 1 mL, 5 mL, 10 mL, 15 mL, 20 mL of this solution. Then add water to each solution to make to 100 mL. This solution is used as each standard solution. Take 0.5 mL of this solution and add 4 mL of 6% perchloric acid solution to each solution. Then immediately shake it to mix. Add 0.4 mL of amidol solution and shake it to mix. Add precisely 0.2 mL of ammonium molybdate solution(8.3 \rightarrow 100) and shake it to mix. Using water as a reference solution, absorbance(A_1 , A_2 , A_3 , A_4 and A_5) of each solution is measured at wavelength 750 nm. Separately, take 0.5 mL of water and add 4 mL of 6% perchloric acid solution and shake it to mix. And then add 0.4 mL of amidol solution and shake it to mix. Add precisely 0.2 mL of ammonium molybdate solution(8.3 \rightarrow 100) and shake it to mix. Using water as a reference solution, absorbance(A_0) is measured at wavelength 750 nm. The concentration(μ mol/mL) of phosphoric acid of each solution is plotted along the X axis and the

absorbance($A_T - A_B$) is plotted along the Y axis. Prepare standard curve of phosphoric acid. And extinction coefficient of phosphoric acid is calculated by standard curve.

Procedure : Take 0.4 mL of substrate solution into tube, keep it at $70 \pm 0.5^\circ\text{C}$ precisely for 5 minutes. Then add 0.1 mL of test solution and shake it to mix. Keep this solution at $70 \pm 0.5^\circ\text{C}$ precisely for 15 minutes to react. Add 4 mL of 6% perchloric acid solution and shake it to mix. And then add 0.4 mL of amidol solution and shake it to mix. Add precisely 0.2 mL of ammonium molybdate solution(8.3→100) and shake it to mix. Keep it in running water for 15 minutes and using water as a reference solution. Absorbance(A_T) of enzyme reaction solution is measured at wavelength 750 nm. Separately, take 0.4 mL of substrate solution and add 4 mL of 6% perchloric acid solution and shake it to mix. And then add 0.1 mL of test solution and shake it to mix. And then add 0.4 mL of amidol solution and shake it to mix. Add 0.2 mL of ammonium molybdate solution(8.3→100) and shake it to mix. Keep it in running water for 15 minutes and using water as a reference solution. Absorbance(A_B) of blank enzyme test solution is measured at wavelength 750 nm.

Activity of an enzyme is calculated by the following equation.

$$\text{Phosphodiesterase (units/g)} = (A_T - A_B) \times \frac{1}{E} \times \frac{5.1}{0.1} \times \frac{1}{15} \times \frac{1}{W}$$

A_T : Absorbance of enzyme reaction solution

A_B : Absorbance of blank enzyme test solution

E : Extinction coefficient(absorbance of concentration($\mu\text{mol/mL}$) of phosphoric acid in 5.1 mL of amount of the total reaction solution)

15 : Reaction time(min)

W : Weight of sample in 1 mL of test solution(g)

Definition of Activity : 1 Phosphodiesterase unit corresponds to the amount of enzyme which separates 1 μmol of phosphoric acid per minute from the substrate under the conditions above.

Reagent

Substrate solution : Dissolve 0.113 g of 4-Nitrophenyl- α -D-glucopyranoside in 35 mL of water. And add 5 mL of 1N acetic acid •sodium acetate buffer solution(pH 5.0) to this solution. Then add water to make to 50 mL. The solution is prepared before use.

Substrate solution : Dry 0.1 g of adenosine 3'-monophosphate sodium salt in advance at 105°C for 4 hours. And calculate loss on drying. Weigh precisely adenosine 3'-monophosphate sodium salt as the dried basis corresponding to 0.0183 g. And dissolve it in 10mL of barbital sodium • hydrochloric acid buffer solution(pH 5.0). Then filter it with membrane filter($0.45\mu\text{m}$). The solution is prepared before use.

Amidol solution : Weigh 0.5 g of amidol and 10 g of sodium sulfite. Dissolve them in water to make to 50 mL and filter this solution. The solution is prepared before use.

6% perchloric acid solution : Dilute 20 mL of 60% perchloric acid with water to make to 200 mL.

Barbital sodium• hydrochloric acid buffer solution(pH 5.0) : Take 100 mL of barbital sodium• sodium acetate buffer solution(1/7mol/L) and 40 mL of sodium chloride solution(8.5→100). Add 100 mL of water to this solution and adjust pH to 5.0 with 1N hydrochloric acid. Then add water to make to 500 mL.

Barbital sodium• sodium acetate buffer solution(1/7mol/L) : Weigh 5.88g of barbital sodium and 2.34g of sodium acetic anhydride. And add water to make to 200 mL.

Storage Standard of Phosphodiesterase

Phosphodiesterase should be stored in a hermetic container in a cold dark place.

Phospholipase

Definition Phospholipase includes Phospholipase A₂, Phospholipase D, and Phospholipase B. Phospholipase A₂ is an enzyme obtained from an extract of pig pancreas tissues. However, dilutant or stabilizer can be added for the purpose of activity adjustment and quality preservation. Phospholipase D is obtained from the culture of *Streptomyces griseus*. However, dilutant or stabilizer can be added for the purpose of activity adjustment and quality preservation. Phospholipase B is an enzyme obtained from the culture of *Aspergillus niger*.

Compositional Specifications of Phospholipase

Description Phospholipase is white ~ dark brown powder, particle, paste or colorless ~ dark brown liquid.

Identification When Phospholipase is proceeded as directed under Activity Test, it should have the activity as Phospholipase.

Purity (1) Arsenic : It should be no more than 4.0 ppm tested by Arsenic Limit Test.

(2) Lead : When 5.0 g of Phospholipase is tested by Atomic Absorption Spectrophotometry or Inductively Coupled Plasma Emission Spectroscopy, its content should not be more than 5.0 ppm.

(3) Coliform Group : When Phospholipase proceed as directed under Microbiological Methods for Coliform Group in General Testing Methods in 「Standards and Specifications for Foods」, it should not contain more than 30 per 1 g of this product.

(4) Salmonella : When Phospholipase proceed as directed under Microbiological Methods for Salmonella in General Testing Methods in 「Standards and Specifications for Foods」, it should be negative (-).

(5) E. coli : When Phospholipase proceed as directed under Microbiological Methods for E. coli in General Testing Methods in 「Standards and Specifications for Foods」, it should be negative (-).

Activity Test (activity) Phospholipase A₂ is done by Method 1, and Phospholipase D is done by Method 2. Phospholipase B is applied by Method 3.

Method 1

- Analysis Principle : Activity test is based on hydrolysis of the substrate at 40°C for 5 minutes and pH 8.0.
- Preparation of Test Solution : A suitable amount of sample is diluted with water so that the solution contains 3 ~ 5 IU per 0.5 mL.
- Test Procedure : 25 mL of substrate solution is added to a beaker, which is maintained in a 40°C water bath for 10 minutes to equilibrate. 0.5 mL of Test Solution is added to the 40°C substrate solution. After exactly 5 minutes, 10 mL of modified alcohol is added and stirred immediately to stop the reaction. It is then taken out of the water bath and titrated with 0.02 N sodium hydroxide solution to pH 8.0. The consumed amount is S (mL). Separately, 25 mL of substrate solution, 10 mL of modified alcohol, and 0.5

mL of Test Solution is sequentially mixed. This solution is tested by the Test Procedure above and the consumed amount of 0.02 N sodium hydroxide solution is B (mL).

Activity of an enzyme(phospholipase A₂) is calculated by the following equation.

$$\text{The phospholipase A}_2 \text{ Activity (U/g)} = \frac{(S - B)}{5} \times \frac{N \times 10^3 \times F}{W}$$

N : Normality of sodium hydroxide solution

10³ : Conversion factor from mmol to μmol for acid

W : Weight of sample(g)

5 : Reaction time(minutes)

F : Dilution factor of test solution

Definition of Activity : 1 Phospholipase A₂ Unit(U) corresponds to an amount of enzyme that frees 1 μmol of acid (H⁺) from substrate per minute under the test conditions above.

Solutions

- 0.016 M Sodium Deoxy Cholate Solution : 6.7 g of sodium deoxy cholate (C₂₄H₃₉NaO₄) is dissolve in water (total volume = 1,000 mL).
- 0.32M Calcium Chloride Solution : 4.7 g of calcium chloride (CaCl₂·2H₂O) is dissolve in water (total volume = 100 mL).
- Substrate Suspension : One egg yolk is homogenized in 100 mL of water, which is filtered through a twofold gauze. 5 mL of 0.32 M calcium chloride solution is added to the filtrate.
- Substrate Solution : 100 mL of substrate suspension and 50 mL of 0.016 N sodium deoxy cholate solution are mixed, where water is added to bring the total volume to 250 mL. pH of the mixture is adjusted to 8.0 with 0.5 N sodium hydroxide solution.

Method 2

- Analysis Principle : Activity test is based on hydrolysis of Lecithin at 37°C, pH 5.5.
- Preparation of Test Solution : A suitable amount of sample is diluted with Tris-maleic acid buffer so that the solution contains 0.1 ~ 0.2 Units per 1 mL.
- Test Procedure : Weigh accurately 0.1 mL of substrate solution, 0.1 mL of Tris-maleic acid buffer, 0.05 mL of 0.1 M Calcium Chloride, 0.15 mL of 7.5% Triton X-100 solution, and mix well. Equilibrate the mixture at 37°C for 5 minutes. Add accurately 0.1 mL of test solution to this solution, and shake immediately. Set it aside at 37°C for 10 minutes precisely, and add 0.2 mL of Tris-EDTA solution accurately. Mix this solution, and heat for 5 minutes in a boiling water bath precisely. After cooling, add 4 mL of colorizing solution accurately and shake. It is set aside for 20 minutes at 37°C. Absorption of the this solution is

measured at 500 nm using water as a reference. Separately, absorption (A_B) is measured using water instead of test solution under same procedure. Separately, absorption (A_S) is measured using 0.1 mL of Choline Chloride standard solution instead of test solution by proceeding same procedure.

Activity of an enzyme(phospholipase D) is calculated by the following equation.

$$\text{the phospholipase D Activity (U/g)} = \frac{A-A_B}{A_S-A_B} \times \frac{1.43}{10} \times \frac{1}{W}$$

A : Absorbance of enzyme test solution

A_B : Absorbance of enzyme blank test solutio

A_S : Absorbance of Choline Chloride standard solution

1.43 : Content of Choline Chloride standard solution(mmol/L)

10 : Reaction time(minutes)

Definition of Activity : 1 Phospholipase D Unit(U) corresponds to an amount of enzyme that $1\mu\text{mol}$ of Choline from substrate per minute under the test conditions above.

Solutions

- Standard Solution : Dissolve 0.2 g of choline chloride exactly in water to make 1,000 mL(1.43mM).
- Substrate Solution : Dissolve 0.5 g of Lecithin(Epikuron 200 of Cargill Inc., or its equivalent) in 9.5 mL of water. Set it aside for a day.
- Tris-maleic acid Buffer(pH 5.5) : Weight separately 1.12 g of Tris(hydroxy ethyl)aminomethane and 1.16 g of Maleic acid, and dissolve each samples in water to make 1,000 mL. Measure 25 mL of the solution, and add 0.1N Sodium Hydroxide solution to adjust pH 5.5. Add water to make 100 mL.
- 0.1M Calcium Chloride Solution : Weight 1.47 g of Calcium Chloride in water to make 100 mL.
- Triton X-100 Solution : Weight 7.5 g of Triton- 100polyoxyethylene(10) octyl phenyl ether in water to make 100 mL.
- Tris-EDTA solution : Dissolve 22.6 g of Ethylenediaminetetraacetic acid in Tris-Chloride Buffer Solution(pH 8.0) to make 1,000 mL.
- Tris-Chloride Buffer Solution : Dissolve 12.1 g of Tris in water to make 100 mL, and add 32 mL of 2M Hydrochloric acid and 800 mL of water. If necessary, adjust pH 8.0 by adding Sodium Hydroxide solution or Hydrochloric acid, and make 1,000 mL with water.
- Colorizing solution : Dissolve 3 Unit of choline oxidase, 6 Unit of peroxidase, 0.001 g of phenol, 0.0006 g of 4-aminoantipyrine in 4 mL of HEPES Buffer Solution(pH 7.4).
- HEPES Buffer Solution(pH 7.4) : Weight 11.9 g of *N*-2-hydroxy ethylpiperazine -*N*-2-ethanesulfonic acid and dissolve it in water to make 600 mL. Adjust pH 7.4 with 0.05 N Sodium

Hydroxide solution, and make 1,000 mL with water.

Method 3

- Analysis Principle : This activity test is based on measurement of violet-colored product that is obtained by acylating non-esterified fatty acids, obtained by hydrolysis of lisophosphatidic choline at 55°C, pH 4.5, with coenzyme A and acyl coenzyme A synthetase and then activating by oxidase and peroxidase using spectroscopic method at 550nm.
- Preparation of Test Solution : Phospholipase B is dissolved with distilled water so that the solution contains 0.4 ~ 0.9 Units per 1mL.
- Test Procedure : Place 0.5mL of substrate solution into test tube for enzyme test and allow to stand for 5 minutes at 55±0.1°C. Separately, 0.5mL of colorizing solution A is transferred into test tube for colorizing solution and isothermalized at 37±0.1°C. Pipette 50µl of test solution into test tube for enzyme test and react for 10 minutes. 50µl of reacting solution is transferred into test tube for colorizing solution isothermalized at 37°C. After having a reaction for 10 minutes, add 1mL of colorizing solution B and react for 10 minutes. Then, shake each test tube to mix well. Using distilled water as a reference, absorbance of each solution is measured at 550nm. For substrate blank test, add 50µl of distilled water, instead of test solution. Process in the same manner with enzyme test.
- Preparation of calibration curve : 1.0 µmol/mL oleic acid in NEFA C kit is diluted to each concentration to 0.25, 0.5, 0.75, and 1.0 µmol/mL. These solutions is used as standard solution. Transfer 50µl of each of the standard solution into 0.5mL of colorizing solution A which is previously isothermalized at 37°C. React for 10 minutes and add 1.0mL of colorizing solution B. After having a reaction, shake each test tube to mix well. Using distilled water as a reference, absorbance of each solution is measured at 550nm and prepare calibration curve. The activity of the enzyme preparation is calculated by the following equation.

$$\text{The activity (Units/g)} = \frac{P}{W \times T}$$

P : Amount of fatty acid that is produced by enzyme reaction(µmole) =

$$\frac{\text{Volume of enzyme reaction solution}(0.55\text{mL})}{\text{Volume of colorizing reaction solution}(0.05\text{mL})} \times \text{Amount of the produced fatty acid}^*$$

W : Amount of enzyme in enzyme test solution =

$$\frac{\text{Weight of the sample}(g)}{\text{Volume of diluted solution}(mL)} \times \text{Amount of enzyme test solution}(0.05\text{mL})$$

* : The amount of the produced fatty acid is the value of the absorbance of the sample less that of the blank test solution

T : Reaction time(minutes)

Definition of Activity : 1 unit of phospholipase B is the amount of enzyme that decompose 1 μ mole of fatty acids from the substrate per minute under the test condition as above.

Solutions

Substrate solution : 0.05g of L- α -lysophosphatidyl choline(Sigma L-4129 or its equivalent) is dissolved in 5mL of buffer solution and is diluted with water to make 10mL of substrate solution.

0.05M Acetic acid buffer solution(pH 4.5) : 6.1mL of 0.5M acetic acid and 3.9mL of 0.5M sodium acetate(4.1g of sodium acetate anhydrous is dissolved in water to 100mL) are mixed, and adjusted to pH 4.5 by using 0.5M acetic acid. Then dilute the solution with water to make volume of 100mL.

Colorizing solution A, B : Use the solution A and B in NEFA kit(Wako chemical, Wako Diagnostics).

Standard solution : Use oleic acid standard solution in NEFA kit.

Storage Standards of Phospholipase

Phospholipase should be stored in cold and dark container.

Phosphoric Acid

Chemical Formula: H_3PO_4

Molecular Weight: 98.00

INS No.: 338

Synonyms: Orthophosphoric acid;
Monophosphoric acid

CAS No.: 7664-38-2

Compositional Specifications of Phosphoric Acid

Content Phosphoric Acid should contain not less than 75.0% of phosphoric acid (H_3PO_4).

Description Phosphoric Acid is a colorless, transparent syrupy liquid. It is odorless.

Identification (1) Phosphoric Acid solution (1→20) is acidic.

(2) To Phosphoric Acid solution (1→20), add 2 ~ 3 drops of phenolphthalein solution, and neutralize with sodium hydroxide solution. The solution responds to the test for Phosphate.

Purity (1) Chloride : 1.78 g of Phosphoric Acid is tested by Chloride Limit Test, and its content should not be more than 200 ppm.

(2) Sulfate : When 0.2 g of Phosphoric Acid is dissolved in water to make 50 mL of solution and tested by Sulfate Limit Test, its content should not be more than the amount that corresponds to 0.6 mL of 0.01 N sulfuric acid.

(3) Nitrate : 3.48 g of Phosphoric Acid is dissolved in 10 mL of water, where 5 mg of sodium chloride is added. When 0.1 mL of indigocarmin solution and 10 mL of sulfuric acid are added to this solution, the blue color of the solution should not disappear in 5 minutes (Not more than 5 ppm).

• Indigocarmin solution : 0.18 g of indigocarmin is dissolved in water to make 100 mL solution.

(4) Arsenic : It should be no more than 2.6 ppm tested by Arsenic Limit Test.

(5) Lead : When 5.0 g of Phosphoric Acid is tested by Atomic Absorption Spectrophotometry or Inductively Coupled Plasma Emission Spectroscopy, its content should not be more than 4.0 ppm.

(6) Cadmium : When 5.0 g of Phosphoric Acid is tested by Atomic Absorption Spectrophotometry or Inductively Coupled Plasma Emission Spectroscopy, its content should not be more than 1.0 ppm.

(7) Mercury : When Phosphoric Acid is tested by Mercury Limit Test, its content should not be more than 1.0 ppm.

(8) Volatile Acid : 60.05 g of Phosphoric Acid is dissolved in 75 mL of freshly and cooled water, which is distilled to 50 mL. It is titrated with 0.1 N sodium hydroxide solution. The consumed amount of titrant should not exceed 0.1 mL.

Indicator : Phenolphthalein solution (Not more than 10 ppm as acetic acid)

(9) Fluoride : 1 g of Phosphoric Acid is precisely weighed and is tested by purity (8) for 「Calcium Citrate」, its content should not be more than 10 ppm.

Assay Accurately weigh about 1.5 g of Phosphoric Acid, dissolve in 25 mL of water, keep the temperature at about 15°C, and titrate with 1 N sodium hydroxide (indicator : 5 drops of thymol phthalein solution) until the color of the solution changes to light blue.

1 mL of 1 N sodium hydroxide = 49.00 mg of H_3PO_4

Phytic Acid

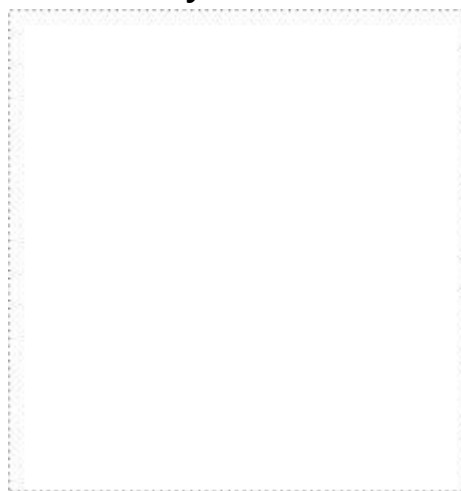

Chemical Formula: $C_6H_{18}O_{24}P_6$

INS No.: 391

Molecular Weight: 660.04

CAS No.: 83-86-3

Definition Phytic Acid is obtained by extracting with water or acidic aqueous solution from rice (*Oryza sativa* LINNE) bran or corn (*Zea mays* LINNE) seeds of gramineae, followed by purification. Its major component is Inositol hexaphosphoric acid.

Compositional Specifications of Phytic Acid

Content Phytic Acid contains 48.0~52.0% of phytic acid ($C_6H_{18}O_{24}P_6 = 660.08$).

Description Phytic Acid is clear scentless pale yellow syrup-phase liquid with a strongly acidic taste.

Identification (1) 3 drops of phenolphthalein TS is added to an aqueous solution (1→10) of this additive, which is neutralized by sodium hydroxide solution. When silver nitrate solution (1→100) is added to this solution, white colloidal precipitation is established.

(2) 3 mL of sulfuric acid is added to 1 mL of Phytic Acid, which is hydrolyzed by heating for 3 hours in a Kjeldahl flask. Add phenolphthalein TS, and neutralize the solution with sodium hydroxide solution. The neutralized solution shows the reaction (2) of Phosphates in Identification.

(3) Add 7 mL of 30% sulfuric acid, and hydrolyze by heating for 5 hours at 130°C in a sealed tube. Neutralize it with sodium hydroxide solution, and add some water to the 50 mL. After adding 0.5 g of activated carbon, it is stirred for 10 minutes and 30 mL of filtered solution is taken. 6 mL of nitric acid is added to 5 mL of this filtrate, which is evaporated to dryness in a water bath. 0.5 mL of barium chloride solution (1→10) is added to a small portion of the residue. When this is evaporated to dryness in a water bath, the residue becomes red color.

Purity (1) Chloride : 0.4 g of Phytic Acid is diluted to 10 mL with water. This solution is used as the test solution. The content should not be more than that amount corresponds to 0.45 mL of 0.01 N hydrochloric acid under Chloride Test.

- (2) Sulfate : 0.4 g of Phytic Acid is diluted to 10 mL with water. This solution is used as the test solution. The content should not be more than that amount corresponds to 0.6 mL of 0.01 N sulfuric acid under Sulfate Limit Test.
- (3) Arsenic : It should be no more than 3.0 ppm tested by Arsenic Limit Test.
- (4) Lead : When 5.0 g of Phytic Acid is tested by Atomic Absorption Spectrophotometry or Inductively Coupled Plasma Emission Spectroscopy, its content should not be more than 2.0 ppm.
- (5) Free Inorganic Phosphorus : Dissolve 1.0 g of Phytic Acid in 500 mL of water, add 5 mL of ascorbic acid solution (1→100) to 3 mL of this solution. Dilute the resulting solution to 50 mL with acetic acid-sodium acetate buffer solution (pH 4.0), which is set aside for 15 minutes, use the Test Solution. Determine the absorbance of the Test Solution at 750 nm. Separately, dilute 5 mL of potassium phosphate monobasic standard solution to 1,000 mL with water. Add 5 mL each of ascorbic acid solution (1→100) to 5.0 mL, 10.0 mL, and 20.0 mL of this solution, respectively. A calibration curve is prepared by following the same procedure as as described test solution. A reference solution is prepared by mixing 5 mL of ascorbic acid solution (1→100) and 5 mL of molybdate solution, which is 1 g ammonium molybdate in 100 mL of 0.05 N sulfuric acid, and dilute to 50 mL with acetic acid-sodium acetate buffer solution (pH 4.0). The content of free inorganic phosphorus in the absorption of Test Solution and the calibration curve should not be more than 1.0%.

Assay (1) Total Phosphorus : 1.5 g of Phytic Acid is precisely weighted into a 200 mL Kjeldahl flask, Add 10 mL of sulfuric acid and 2.5 mL of nitric acid. This is hydrolyzed by heating until the liquid becomes transparent. Cool the solution, and dilute the resulting solution to 500 mL with water. Transfer 3 mL of this solution into a 100 mL volumetric flask, and neutralize with ammonia water (1→4), and weakly acidify with diluted nitric acid (1→10). 20 mL of metavanadate · molybdate solution are added to the resulting solution, which is diluted to 100 mL with water, mixed by shaking, and set aside for 30 minutes. This solution is used as the test solution. Measure the absorbance at 420 nm. Separately, dilute 5 mL of potassium phosphate monobasic standard solution to 1,000 mL with water. To determine the calibration curve, place 5.0 mL, 10.0 mL, and 20.0 mL of this solution into a 100 mL volumetric flasks, respectively, and Proceed as directed under Test Solution. Calculate the content(%) of total phosphorus by using the absorption of Test Solution and the calibration curve.

- (2) Bonded Phosphorus : Calculate the content of bonded phosphorus from the difference between free inorganic phosphorus and total phosphorus, and calculate the content of phytic acid by the formula;

$$\text{Content of phytic acid (\%)} = \text{Content of bonded phosphorus(\%)} \times 3.552$$

Solutions

- Metavanadate·molybdate solution : Dissolve 1.12 g of ammonium metavanadate in excess amount of water, where 250 mL of nitric acid is added. Dissolve 27 g of ammonium molybdate in an appropriate amount of water. Two

solutions are mixed so that the total volume is 1,000 mL. Store in light-resistant containers.

Piperonal



Chemical Formula: $C_8H_6O_3$

Molecular Weight: 150.13

Synonyms: 3,4-(Methylenedioxy)-benzaldehyde;
Heliotropine; Piperonyl aldehyde

CAS No.: 120-57-0

Compositional Specifications of Piperonal

Content Piperonal, when calculated on the dried basis, should contain not less than 99.0% of piperonal ($C_8H_6O_3$).

Description Piperonal occurs as white crystals or lumps, having a characteristic odor.

Identification (1) Dissolve 0.1 g of Piperonal in 2 mL of sulfuric acid. and add 2 drops of a solution of resorcin in alcohol (1→20). A dark red color develops.

(2) Melt 1 g of Piperonal while warming, add 5 mL of sodium hydrogen sulfite solution, and heat in a water bath while shaking. White crystalline lumps are formed.

Purity (1) Melting Point : Melting point of Piperonal should be within a range of 36.0 ~ 37.5°C.

(2) Clarity and Color of Solution : 1 g of Piperonal is dissolved in 4 mL of 70% ethanol. This solution should be Clear.

(3) Arsenic : It should be no more than 4.0 ppm tested by Arsenic Limit Test.

(4) Lead : When 5.0 g of Piperonal is tested by Atomic Absorption Spectrophotometry or Inductively Coupled Plasma Emission Spectroscopy, its content should not be more than 10 ppm.

Loss on Drying When Piperonal is dried for 4 hours in a vacuum desiccator(silica gel), the weight loss should not be more than 0.5%.

Residue on Ignition When thermogravimetric analysis is done with Piperonal, the residue should not be more than 0.05%.

Assay Accurately weigh about 1 g of Piperonal, previously dried, and proceed as directed under Method 2 in Aldehyde and Ketone Content in Flavoring Substances Tests. In the procedure, allow the mixture to stand for 15 minutes.

1 mL of 0.5 N hydrochloric acid = 75.07 mg of $C_8H_6O_3$

Polybutene

Compositional Specifications of Polybutene

Description Polybutene is a colorless to pale yellow, viscous liquid. It is odorless or has a slight, characteristic odor, and tasteless.

Identification (1) Approximately 1 g of polybutene is dissolved in 5 mL of n-hexane. 2 ~ 3 drops of this solution are applied to a window plate on an area of 2.5×1cm proceed as directed under Thin Film Method in Infrared Spectroscopy. A characteristic absorption band at wavelengths ($\pm 0.5\%$) shown in the following Figure.

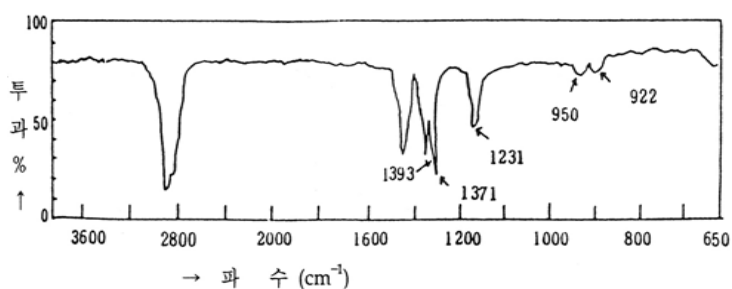

- (2) 0.5 g of polybutene is dissolved in 5 mL of n-hexane. When 2 drops of bromine solution are added to this solution, the color of the solution immediately disappears.
- (3) When polybutene is slowly heated, an odor of burning pine resin is generated.

Purity (1) Clarity and Color of Solution : When 0.4 g of polybutene is dissolved in 5 mL n-hexane, the solution should be clear.

(2) Chlorinated compounds : 0.5 g of polybutene is transferred into a platinum porcelain, where 0.7 g of calcium carbonate is mixed. The content is reduced to ash by gently heating. After cooling, the residue is dissolved in 20 mL of diluted nitric acid, which is then filtered. Filtrate is proceeded as directed under Purity (2) in 「Benzoic Acid」.

(3) Arsenic : It should be no more than 4.0 ppm tested by Arsenic Limit Test.

(4) Lead : When 5.0 g of Polybutene is tested by Atomic Absorption Spectrophotometry or Inductively Coupled Plasma Emission Spectroscopy, its content should not be more than 2.0 ppm.

(5) Low Molecular Weight Polymer : Accurately weigh about 10 g of Polybutene and add 10 mL of methanol. Equip with a reflux condenser. Heat in a water bath for 1 hour while shaking occasionally, and allow to stand in a dark place for 1 hour. Transfer the supernatant to an evaporating dish, which is weighed prior to use, dry almost completely at about 50°C, and dry in a vacuum desiccator (sulfuric acid) for 15 ~ 20 hours, the content should not be more than 0.4%

Residue on Ignition When thermogravimetric analysis is done with 5 g of Polybutene, the residue should not be more than 0.05%.

Polydextrose

INS No.: 1200

Synonyms: Modified polydextroses

CAS No.: 68424-04-4

Definition Randomly bonded condensation polymer of glucose with some sorbitol end-groups, and with citric acid or phosphoric acid residues attached to the polymer by mono diester bonds. Polydextrose may be neutralized with alkali and decolorized and deionized for further purification. It may be partly reduced by hydrogenation. In the case of liquid, it should contain 70~80% of polydextrose .

Compositional Specifications of Polydextrose

Content Polydextrose, when calculated on the dried basis(excluded ash), should contain not less than 90.0% of the polymer.

Description Polydextrose is white ~ pale brown amorphous powder or liquid.

Identification (1) To Polydextrose solution (1→10), add 4 drops of 5% phenol solution and 15 drops of sulfuric acid. The solution becomes dark yellow ~ orange color.

(2) To 10 mL of Polydextrose solution (1→10), add 1.0 mL of acetone and stir vigorously, it should stay clear.

(3) To the Test Solution (2), add 2.0 mL of acetone and vigorously stir. The solution shows severe milky turbidity.

(4) To 1 mL of Polydextrose solution (1→50), and 4 mL of alkaline cupric citrate . After boiling vigorously for 2 ~ 4 minutes, it is settled and cooled, then supernatant becomes blue-green color.

Purity (1) pH : When Polydextrose proceed as directed under glass electrode method, pH of Polydextrose solution (1→10) should not be less than 2.5. In the case of liquid, pH of Polydextrose solution (1.4→10) is measured .

(2) Monomer : 20 mg of Polydextrose(an equivalent amount of 20 mg of solid in the case of liquid) is precisely weighed into a vial with a cap. 1 mL of octadecane solution, 1 mL of pyridine, and 0.5 mL of N-trimethyl silyl imidazole are added to the vial, which is then capped. The vial is sonicated for 60 minutes at 70°C use the Test Solution. Separately, 1 mL of standard solution, 1 mL of octadecane, 0.5 mL of N-trimethyl silyl imidazole are processed with the same procedure as the Test Solution use the Reaction Standard Solution. Same amounts of the Reaction Standard Solution and the Test Solution are injected into gas chromatography. The content of each monomer is calculated from the following equation. The content of 1,6-anhydro-D-glucose should not be more than 4.0% and the content of sorbitol and D-glucose combined should not be more than 6.0%. An average value should be obtained by injecting the Reaction Standard Solution twice.

$$\text{Content(\%)} = \frac{R \times W_s}{R_s \times W}$$

W : Weight of the sample (mg) (as a dehydrated form without ash)

W_s : Weight of each standard material (mg)

R : Peak area ratio of each monomer vs. octadecane in Test Solution

R_s : Average peak area ratio of each monomer vs. octadecane in Reaction Standard Solution

Operation Conditions

-Column : A glass or stainless tube with inner diameter of 2 mm and length of 2.5 m

-Column Filler : 100~120 mesh Gas Chrom Q coated with 3% OV-1

-Detector : (Hydrogen) Flame Ionization Detector (FID)

-Temperature at injection hole: 210°C

-Column Temperature : 175°C

-Detector Temperature : 230°C

-Carrier gas and flow rate : Nitrogen, 30 mL per minute

The elution order of the monomers is 1,6-anhydro-D-glucose(levoglucosan), n-octadecane α-D-glucose, D-sorbitol, and β-D-glucose.

Solution

• Standard Solution : 100 mL pyridine solution of each (precisely weighed) 50 mg α-D-glucose, 50 mg β-D-glucose, 40 mg anhydrous-D-sorbitol, 35mg 1,6-anhydro-D-glucose 35mg.

• Octadecane solution : 100 mL pyridine solution of precisely weighed 50 mg of octecane.

(3) 5-Hydroxy Methylfurfural (HMF) : 1 g of Polydextrose(an equivalent amount of 1 g of solid in the case of liquid) is precisely weighed into a 100 mL volumetric flask, which is filled with water use the Test Solution. Using water as a reference, absorbance at 283 nm with 1 cm path length is measure. The content of 5-hydroxy methylfurfural is calculated using the following equation. The content (as a dehydrated form excluding ash) should not be more than 0.1%. However, the neutralized form should not be more than 0.05%.

$$\text{5-hydroxy methylfurfural(\%)} = \frac{0.749 \times A}{C}$$

A : Absorbance of Test Solution

C : Concentration of Test Solution (mg/mL) (as a dehydrated form excluding ash)

(4) Arsenic : It should be no more than 4.0 ppm tested by Arsenic Limit Test.

(5) Molecular Weight Limit : 4 g of Polydextrose(an equivalent amount of 4 g of solid in the case of

liquid) is dissolved in 0.2 M phosphate buffer solution (pH 6.8) to make 100 mL. 4 g of each dextran standard T 70 (molecular weight 74,300), T 40 (molecular weight 40,600) and T 10 (molecular weight 9,400) is dissolved in 0.2 M phosphate buffer solution (pH 6.8) and the total volume is made to 100 mL, respectively, use the Standard Solutions. A calibration curve is prepared with 50 µl of each standard solution following the operation conditions below. From the calibration curve, an elution time (t) for a molecular weight of 22,000 is obtained. Separately, 50 µl of Test Solution is injected and eluted. Under t, the height of any peak should not exceed 2% of the height of the major peak.

Peration Conditions

- Detector : Differential refractometer (RI Detector)
- Column : TSK-GEL-G 3000 PW, 7.5 mm × 600 mm stainless steel tube
- Column Temperature : Room temperature
- Mobile Phase : 0.2 M Phosphate buffer solution (pH 6.8)
- Flow Rate : 1.0 mL/min
- Measurement : 2×10^{-5} RIUFS

Solution

- 0.2 M phosphate buffer solution (pH 6.8)
- Solution 1 : 27.218 g of potassium phosphate, monobasic is dissolved in water and to make total volume 1 l.
- Solution 2 : 71.6 g of potassium phosphate, monobasic is dissolved in water and to make total volume 1 l.

Solution 1 is added to Solution 2 while mixing until pH becomes 6.8.

(6) Lead : When 5 g of Polydextrose (an equivalent amount of 5 g of solid in the case of liquid) is tested by Atomic Absorption Spectrophotometry or Inductively Coupled Plasma Emission Spectroscopy, its content should not be more than 0.5 ppm.

(7) Nickel : When 5.0 g of Polydextrose (an equivalent amount of 5 g of solid in the case of liquid) is tested by Atomic Absorption Spectrophotometry or Inductively Coupled Plasma Emission Spectroscopy, its content should not be more than 2.0 ppm. (limited to the form under hydrogen reduction)

Residue on Ignition When thermogravimetric analysis is done with 2 g of Polydextrose (an equivalent amount of 2 g of solid in the case of liquid), the amount of residue should not be more than 0.3%. However, the neutralized form should not be more than 2.0%.

Water Content Water content of Polydextrose proceed as directed under back titration method in water determination (Karl-Fisher Titration) and should not be more than 4.0%. In the case of liquid, it should be 27.5~32.5%.

Assay 250 mg of Polydextrose (an equivalent amount of 250 mg of solid in the case of liquid) transfer into a 250 mL volumetric flask and the flask is filled. 10 mL of the solution is diluted to 250 mL. 2 mL each of the resulting solution is taken into three 8 mL vials. 0.12 mL of phenol solution (8→10) is added to each vial and gently mixed. Then 5 mL of sulfuric acid is quickly added and shaken vigorously with

a cap in place (should wear rubber gloves and use safety shield). Each vial is set-aside for 45 minutes at normal temperature and absorption is measured at 490 nm with 1 cm path length. Separately, a calibration curve is prepared by following the same procedure as above with 2 mL each of glucose standard solution and prepare a standard curve of concentration. The content of polymer (P) is calculated from the following equation. Separately, a reference solution is prepared by following the same procedure as the test solution with 2 mL of water, 0.12 mL of phenol solution (8→10), and 5 mL of sulfuric acid.

$$P = 1.05 \times \left[100 \times \frac{(A - Y)}{S \times C} \right] - P_g - 1.11P_1$$

A : Average absorption of the Test Solution

Y : Intercept (y axis) in the standard curve

S : Slope of absorption vs. glucose concentration (g/mL) in the standard curve(S is approximately 0.02)

C : Concentration of the test solution (g/mL) (converted to dehydrated form excluding ash.)

P_g, P₁ : Contents of glucose and 1,6-anhydro-D-glucos as measured by monomer test.

Solution

- Glucose Standard Solution : 100 mg of α-D-glucose is precisely weighed, dissolved in water, and diluted to 500 mL (200 µg/mL). This is further diluted to 50 µg/mL, 40 µg/mL, 20 µg/mL, 10 µg/mL, and 5 µg/mL.

Polyethylene Glycol

PEG

Chemical Formula: $(C_2H_4O)_{n+1}H_2O$

Molecular Weight: 200~9500

INS No.: 1521

Synonyms: Macrogol; PEG

CAS No.: 25322-68-3

Compositional Specifications of Polyethylene Glycol

Definition Polyethylene glycol is a polymer of ethylene oxide and water. The molecular weight is 200 to 9,500.

Description Polyethylene glycol having molecular weight less than 700 are colorless, transparent or semi-transparent, and slight hygroscopic liquids with a characteristic smell. Polyethylene glycol having molecular weight between 700 and 900 is semisolid. Polyethylene glycol having molecular weight more than 1000 is almost white mass, thin slice or powder.

Identification

- (1) Polyethylene glycol is soluble in water, insoluble in ether.
- (2) Polyethylene glycol having molecular weight under 1000 is between 95.0%~105.0% of the declared value. Polyethylene glycol having molecular weight between 1000 and 7000 is not less than 90.0% and not more than 110.0% of the declared value. Polyethylene glycol having molecular weight over 7000 is not less than 87.5% and not more than 112.5% of the declared value. First, sample bottle is maintained in a water bath heated at $98 \pm 2^\circ\text{C}$ for 30~60 minutes. After cooling down to room temperature, add 5 drops of phenolphthalein solution in pyridine(1→100) and titrate with 0.5N sodium hydroxide. When the pink color of the solution maintains for about 15 seconds, it is regarded as the end point. Separately, a blank test is carried out by the same method. The molecular weight is calculated by the following equation.

$$\text{Average Molecular weight} = \frac{2000W}{(B-S) N}$$

W = weight of the sample(g)

B = consumed volume of 0.5N NaOH by the blank test(mL)

S = consumed volume of 0.5N NaOH by the test with sample(mL)

N = Normality of NaOH solution

Phthalic anhydride solution : Put 49g of phthalic anhydride in an amber bottle and dissolve it in 300mL of pyridine freshly distilled. Shake the bottle vigorously until the reaction occurs in the solution and then allow to stand overnight before use.

Liquid polyethylene glycol : Place 25mL of phthalic anhydride solution into container which is resistant to heat and pressure. The amount of the sample equivalent to the declared molecular weight divided by 160 is accurately weighed(e.g. a sample of about 1.3g would be applied for PEG 200, about 3.8g for PEG 600). Close the bottle with stopper and carefully cover the bottle in a fabric bag.

Solid polyethylene glycol : Place 25mL of phthalic anhydride solution into container which is resistant to heat and pressure. The amount of the sample equivalent to the declared molecular weight divided by 160 is accurately weighed and added to the same bottle. Add 25mL of pyridine that is freshly distilled by phthalic anhydride and mix well until the start of the reaction. Close the bottle with stopper and carefully cover the bottle in a fabric bag.

Purity

- (1) pH of polyethylene glycol's aqueous solution(1→20) should be within a range of 4.5~7.5.
- (2) Acid value(as acetic acid) : 2 drops of phenolphthalein and 50mL of neutral ethanol are added to 6g of polyethylene glycol. Titrate with 0.1N ethanolic potassium hydroxide until pale red color persists for 15 seconds. The consumed amount should be not more than 0.5mL.
- (3) Viscosity : When the viscosity is measured by Method 1 Capillary Viscosity Measurement in Viscosity at $100\pm 0.3^{\circ}\text{C}$, the viscosity of the sample by molecular weight is as follows:

Average MW	Viscosity range(cSt)	Average MW	Viscosity range(cSt)
200	4.1-4.8	2400	49.0-65.0
300	5.4-6.4	2500	51.0-70.0
400	6.8-8.0	2600	54.0-74.0
500	8.3-9.6	2700	57.0-78.0
600	9.9-11.3	2800	60.0-83.0
700	11.5-13.0	2900	64.0-88.0
800	12.5-14.5	3000	67.0-93.0
900	15.0-17.0	3250	73.0-105.0
1000	16.9-19.0	3350	76.0-110.0
1100	18.0-22.0	3500	87.0-123.0
1200	20.0-24.5	3750	99.0-140.0
1300	22.0-27.0	4000	110.0-158.0
1400	24.0-30.0	4250	123.0-177.0
1450	25.0-32.0	4500	140.0-200.0
1500	26.0-33.0	4750	150.0-228.0
1600	28.0-36.0	5000	170.0-250.0
1700	31.0-39.0	5500	206.0-315.0

1800	33.0-42.0	6000	250.0-390.0
1900	35.0-45.0	6500	295.0-480.0
2000	38.0-49.0	7000	350.0-590.0
2100	40.0-53.0	7500	405.0-735.0
2200	43.0-56.0	8000	470.0-900.0
2300	46.0-60.0		

※ For viscosity range not listed in the above table, calculate the value using the interpolation method.

(4) 1,4-Dioxane : To 0.5g of polyethylene glycol and 0.1g of defoamer(containing silicone), add 10mL of water and diffuse with ultrasonic waves for 10 minutes, test solution. Transfer this solution into 25mL of frit sparger, hold the temperature of container at 50°C, and analyze with Purge and Trap Gas chromatograph. Separately, to the solution, which 5µg of 1,4-dioxane is contained in 10mL of water, add 0.1g of defoamer, standard solution. Analyze the standard solution in the same manner as the sample(not more than 10ppm).

Operation Condition

Purge and Trap

Trap : Vorcarb 3000 or its equivalent

Purge time : 11 minutes

Desorption temperature and time : 250°C, 4 minutes

Cryo focus temperature : -150°C

Bake temperature and time : 260°C, 10 minutes

Gas chromatography

Column : HP-FFAP(60m × 0.32µm) or its equivalent

Detector : (Hydrogen) Flame Ionization Detector (FID)

Column Temperature : held at 70°C for 5 minutes and is raised to 180°C at a rate of 5°C per minute

Injector Temperature : 220°C

Detector Temperature : 250°C

Carrier gas and flow rate : Nitrogen, 0.9 mL/min

(5) Ethylene oxide : 25g of Polyethylene glycol(W1), accurately weighed is transferred to the container which is resistant to heat and pressure with 50mL of morpholine solution. Shake the mixture to be completely dissolved. Close the bottle with stopper and carefully cover the bottle in a fabric bag. Place them in water bath at 98±2°C for 30 minutes and take the bottles from the bath, and cool at room temperature. Loosen the fabric bag, and open cautiously the stopper to release pressure inside the bottle. Add slowly 20mL of acetic anhydride to the bottle, shake to dissolve completely. Cool this solution

at room temperature and then add 4~6 drops of mixed indicator solution. Titrate with standard methanolic hydrochloric acid to be the end point, a clear blue color(A). Separately, place 50mL of morpholine solution into the heat and pressure-resistant container. Add 4~6 drops of mixed indicator solution. Titrate with standard methanolic hydrochloric acid to be the end point, a clear blue color(B). Transfer 50mL of anhydrous methanol into 250mL-flask and add 4~6 drops of mixed indicator solution. Titrate with standard methanolic hydrochloric acid to be the end point, a clear blue color. Add 25g of Polyethylene glycol(W2) and shake the mixture to be completely dissolved. Titrate with standard methanolic hydrochloric acid to be the end point, a clear blue color(C). Calculate the content of ethylene oxide according to the following equation. It should be below 0.02%.

$$\text{The percentage of ethylene oxide (\%)} = 4.41 \times N \times \frac{(A-B)}{W1 - \frac{C}{W2}}$$

N = the normality of the standard methanolic hydrochloric acid solution (mol/L)

W1 = weight of the sample(g)

W2 = weight of the sample for the blank test(g)

A = consumed volume of methanolic hydrochloric acid solution used for titration of test solution(mL)

B = consumed volume of methanolic hydrochloric acid solution used for titration of indicator's blank test(mL)

C = consumed volume of methanolic hydrochloric acid solution used for titration of sample's blank test(mL)

Test solution

Morpholine solution : Dilute redistilled morpholine with anhydrous methanol solution(1→9).

Mixed indicator solution : Accurately weigh 0.05g of 4,4'-bis-(amino-1-naphthylazo- 2,2'-stilbenedisulfonic acid) and 0.01g of brilliant yellow into 60mL-glass bottle. Add 1.5mL of 0.1M sodium hydroxide and mix well. Add 3.5mL of distilled water and transfer the mixture to the bottle for storage. Rinse the bottle with 45mL of methanol and transfer it to storage bottle and mix.

Standard methanolic hydrochloric acid : Mix 8.5mL of hydrochloric acid and 1000mL of anhydrous methanol and standardize by titrating 9mL with 0.1N sodium hydroxide solution to end-point of phenolphthalein indicator. If this solution is used more than 48 hours after standardization, the solution needs to be re-standardized.

(6) Ethylene glycol and diethylene glycol : The test of ethylene glycol and diethylene glycol should be conducted by depending on molecular weight as follows:

a. Polyethylene glycol having molecular weight less than 450 : Accurately weigh about 4.0 g of the sample and add water to make 10mL(Test solution). Separately, 0.1~0.6g of ethylene glycol and diethylene glycol standard is accurately weighed and added to water to 100mL so that each concentration of glycol is within a range of 1~6mg/mL(Standard solution). Inject 2μl of Test solution and

Standard solution into the gas chromatograph and test by the following condition, its content should be less than 0.25% as the total amount of ethylene glycol and diethylene glycol.

$$\text{The amount of ethylene glycol (\%)} = \frac{H_{ta}}{H_{sa}} \times \frac{E_{sa}}{\text{weight of the sample(g)}} \times 100$$

$$\text{The amount of diethylene glycol (\%)} = \frac{H_{tb}}{H_{sb}} \times \frac{E_{sb}}{\text{weight of the sample(g)}} \times 100$$

E_{sa} : Amount of ethylene glycol in 1mL of standard solution (mg)

E_{sb} : Amount of diethylene glycol in 1mL of standard solution (mg)

H_{sa} : Peak height of ethylene glycol in standard solution (mm)

H_{sb} : Peak height of diethylene glycol in standard solution (mm)

H_{ta} : Peak height of ethylene glycol in test solution (mm)

H_{tb} : Peak height of diethylene glycol in test solution (mm)

Operation conditions

- Detector : Hydrogen flame ionization detector(FID)
- Column : Stainless steel tube (length : 1.5m, internal diameter : 3mm)
- Column filler : 60~800 Mesh Chromosorb W(or its equivalent) for Gas chromatography coated with 12% sorbitol
- Carrier gas and flow rate : Nitrogen, 70mL/min
- Column temperature : 165°C
- Injector temperature : 260°C

b. Polyethylene glycol having molecular weight more than 450 : Accurately weigh 50.0g of the sample and transfer it into 250mL distillation flask. Add 75mL of diphenyl ether and dissolve. A distilled solution is slowly obtained in 1~2mmHg of Mercury using mercury vapor apparatus. Add 25mL of water and mix well, then set aside to make a separate layer. Cool down in an ice bath to solidify diphenyl ether and help remove it. The water layer is filtered with filter paper into 50mL glass-stoppered graduated cylinder. Filtrate is added to its same amount of freshly distilled acetonitrile(Test solution). Separately, accurately weigh 50mg of diethylene glycol standard to 25mL volumetric flask. Add freshly distilled acetonitrile to be 25mL of acetonitrile : water (1:1) (Standard solution). Add 10mL of each of the test solution and the standard solution into 50mL flask containing 15mL of ceric ammonium nitrate test solution, and mix. Within 2~5 min, measure the absorbance at wavelength of 450nm. Separately, blank test solution is the

mixture of 15mL of ceric ammonium nitrate and 10mL of acetonitrile : water (1:1). measure the absorbance at wavelength of 450nm. The absorbance of test solution should not exceed that of standard solution.

Ceric ammonium nitrate test solution : accurately weigh 6.25g of ceric ammonium nitrate $[(\text{NH}_4)_2\text{Ce}(\text{NO}_3)_6]$ and dissolve in 0.25N of nitrate solution to 100mL.

(7) Lead : When 5.0g of polyethylene glycol is tested by Atomic Absorption Spectrophotometry of Inductively Coupled Plasma Emission Spectroscopy, its content should not be more than 1.0ppm.

Residue on Ignition When thermogravimetric analysis is done with 5g of polyethylene glycol, the amount of residue should not be more than 0.1%.

Polyglycitol Syrup

Hydrogenated starch hydrolysate, Polyglucitol

Synonyms: Hydrogenated starch hydrolysate;
Polyglucitol

INS No.: 964

Definition Polyglycitol Syrup is a mixture of sorbitol, maltitol, maltotritol, and hydrogenated saccharide

Compositional Specifications of Polyglycitol Syrup

Content In Polyglycitol Syrup, sorbitol occupies not less than 95% of the peak area of sorbitol and glucose, maltitol does not less than 95% of the peak area of maltitol and maltose. Sorbitol and maltitol contain not more than respectively 50% of the total content.

Description Polyglycitol Syrup is a colorless, odorless, transparent, viscous liquid or white crystalline lump.

Identification (1) Polyglycitol Syrup dissolved well in water and slightly in alcohol.

(2) 50 mg of Polyglycitol Syrup is dissolved in 20 mL of water to make the test solution. Proceed as directed under (4) Identification in [D-maltitol]

(3) To 5 g of Polyglycitol Syrup, add 7 mL of methanol, 1 mL of benzaldehyde and 1 mL of hydrochloric acid and mix them with agitation until crystals appear. The crystals are filtered and then dissolved in 20 mL of boiling water containing 1 g of sodium bicarbonate, and filtered. The resulting solution is cooled until crystals appear. They are filtered again and washed with 5 mL of 50% methanol. The melting point of the dried crystal should be within a range of 173 ~ 179°C.

Purity (1) Reduced saccharides : About 7 g of Polyglycitol Syrup is weighed accurately and proceed as directed under purity (1) in [D-maltitol], the weight of copper oxide should not be more than 50 mg.

(2) Chloride : When 10 g of Polyglycitol Syrup the chloride proceed as directed under chloride, it is content should not be more than the amount that corresponds to 1.5 mL of 0.01 N hydrochloric acid.

(3) Sulfates : When 10 g of Polyglycitol Syrup the chloride proceed as directed under Sulfate, it is content should not be more than the amount that corresponds to 2.0 mL of 0.01 N hydrochloric acid.

(4) Lead : When 5.0 g of Polyglycitol Syrup is tested by Atomic Absorption Spectrophotometry or Inductively Coupled Plasma Emission Spectroscopy, its content should not be more than 1 ppm.

(5) Nickel : When proceed as directed under purity (1) in [D-maltitol] with 10 g of Polyglycitol Syrup, the content should not be more than 2 ppm.

Loss on Drying When Polyglycitol Syrup is dried at 105°C for 4 hours, the reduction of a dried sample should not be more than 15% and that of a liquid sample should not be more than 50%.

Residue on Ignition When proceed as directed under Residue on Ignition with 3 g of Polyglycitol Syrup, the content should not be more than 0.1%.

Assay 0.1 g of Polyglycitol Syrup is accurately weighed and water is added to make 100 mL. The resulting

solution is filtered with 0.45 µm paper to make the test solution. Separately, 0.1 g each of the sorbitol standard, the dextrose standard, the maltitol standard and the maltose standard are weighed accurately, water is added to make 100 mL, use the standard solution. 20 µl each of the standard and test solutions are injected in liquid chromatography in the following conditions, and according to the following formulae, the contents of sorbitol, dextrose, maltitol, and maltose are obtained using the following equation.

Contents (%) of Sorbitol, Dextrose, Maltitol, and Maltose

$$= \frac{\text{Weight of the standard(g)}}{\text{weight of the sample(g)}} \times \frac{\text{Peak area of test solution}}{\text{Peak area of standard solution}} \times 100$$

Operation Condition

- Column : Phenomenex Rezex or its equivalent
- Detector : Differential Refractometer (RI detector)
- Column temperature : 80°C
- Moving phase : water
- Flow speed : 0.5 mL/min

Polyisobutylene

Other name: Butyl rubber

CAS No.: 9003-27-4

Definition Polyisobutylene is a polymer of isobutylene. It may contain not more than 2% of total polymer unit derived from isoprene.

Compositional Specifications of Polyisobutylene

Description Polyisobutylene occurs as a colorless to light yellow elastic rubbery semi-solid or viscous substance. It is odorless or has a slight, characteristic odor, and is tasteless.

Identification Dissolve about 1 g of polyisobutylene in 5 mL of n-hexane and proceed as directed under the Thin Film Method in Infrared Spectrophotometry. Absorptions are observed at about 1,393 cm^{-1} , 1,230 cm^{-1} , 950 cm^{-1} , 920 cm^{-1} .

Purity

- (1) Clarity and Color of Solution : Weigh 0.5 g of Polyisobutylene, add 5 mL of n-hexane, and dissolve while heating in a water bath at 80°C. It should not be more than slightly turbid.
- (2) Chlorinated Compounds : 0.5 g of Polyisobutylene is transferred into a porcelain crucible, where 0.7 g of calcium carbonate. It is reduced to ash by gently heating. After cooling, the residue is dissolved in 20 mL of dilute nitric acid and filtered. The filtrate is tested by Purity (2) for 「Benzoic Acid」.
- (3) Arsenic : It should be no more than 4.0 ppm tested by Arsenic Limit Test.
- (4) Lead : 0.5 g of Polyisobutylene is tested by Atomic Absorption Spectrophotometry or Inductively Coupled Plasma Emission Spectroscopy, its content should not be more than 3.0 ppm.
- (5) Low Molecular Weight Polymer : Accurately weigh about 10 g of Polyisobutylene, add 40 mL of ethyl ether, equip with a reflux condenser, and dissolve while heating on a water bath and shaking occasionally. Cool, add 40 mL of methanol, shake well, and allow to stand in a cold place for 1 hour. Transfer the supernatant to a flask, distill under reduced pressure at about 50°C and dry in a vacuum desiccator for 15 ~ 20 hours. Weigh the residue. It should not be more than 1.2%.
- (6) Total Unsaturated Substances : Accurately weigh 0.5 g of Polyisobutylene, add 100 mL of cyclohexane, stopper tightly the flask, and allow to stand overnight to dissolve completely. If insoluble substances remain, shake for about 1 hour to dissolve them completely. Transfer in a 500 mL flask, wash the flask with a small amount of cyclohexane, and add the washings to the 500 mL flask. Add exactly 15 mL of Wijs test solution, and mix well. If the solution is not clear, add cyclohexane until it becomes clear. Stopper the flask, and allow to stand for 30 minutes at 20~30°C, protected from light, with occasional shaking. Add 20 mL of potassium iodine(1→10) and 100 mL of water, and shake. Titrate the liberated iodine with 0.1 N sodium thiosulfate(indicator: starch test solution), adding the titrant gradually and shaking constantly until the yellow colour of the solution almost disappears. Add starch test solution, and continue the titration until the blue colour disappears entirely. Perform a blank test in the same manner. Calculate the total amount of unsaturated substances by the following formula.

The amount should not be more than 2.0 %.

$$\text{Total amount of unsaturated substances(\%)} = \frac{1.87 \times (a - b) \times N}{\text{Weight of the sample(g)}}$$

a : volume (mL) of 0.1 N sodium thiosulfate consumed in the blank test,

b : volume (mL) of 0.1 N sodium thiosulfate in this test.

N : normality of 0.1 N sodium thiosulfate solution

Residue on Ignition When thermogravimetric analysis is done with 2 g of Polyisobutylene, the residue should not be more than 0.1 %.

Poly- γ -glutamic acid

Definition Poly- γ -glutamic acid is obtained by separating and refining the cultured residue solution after culturing *Bacillus subtilis* and *Bacillus subtilis chungkookjang*. Its compound is Poly- γ -glutamic acid.

Compositional Specifications of Poly- γ -glutamic acid

Content When Poly- γ -glutamic acid is weighted Dried it should contain no less than 95.0% as a Poly- γ -glutamic acid.

Description Poly- γ -glutamic acid is strong hygroscopic property, white powder, scentless and tasteless.

Identification (1) When Thin Layer Chromatography is tested after taking 0.1g of Poly- γ -glutamic acid, red spot should be identified at the same place as L-Glutamic acid. Test solution is made like that 0.1g of Poly- γ -glutamic acid is taken, and dissolve in 9.5mL of water, and then 0.5mL of 6N hydrochloric acid is added in the solution, and is hydrolyzed at 110°C for 24 hours. It can be filtered if it is necessary. Prepared test solution is conducted under the following condition.

Condition of Thin Layer Chromatography

Developing solvent : n-butyl alcohol : glacial acetic acid : water(2 : 1 : 1)

Thin layer plate: Silicagel

Developing distance: 10 ~ 15cm

Color reagent : 0.2g of Ninhydrin dissolve in unsaturated n-butyl alcohol to make 100mL.

(2) When 1g of Poly- γ -glutamic acid is taken, and measured by Potassium Bromide Disk Method of Infrared Spectrophotometry, Carboxyl group(1735cm^{-1}), amin group(1554cm^{-1}) and carboxyl group connected amin group(1650cm^{-1}) should be identified.

Purity (1) Arsenic : It should be no more than 4.0 ppm tested by Arsenic Limit Test.

(2) Lead : When 5.0 g of Poly- γ -glutamic acid is tested by Atomic Absorption Spectrophotometry or Inductively Coupled Plasma Emission Spectroscopy, its content should not be more than 10.0 ppm.

(3) Total Viable Aerobic Count : When Poly- γ -glutamic acid is tested by Microbe Test Methods for Total Viable Aerobic Count (Number of General Germs) in General Test Method in 「Standards and Specifications for Foods」, it should not be more than 10,000 per 1 g

(4) E. Coli : When Poly- γ -glutamic acid is tested by Microbe Test Methods for E. Coli in General Test Method 「Standards and Specifications for Foods」, it should be negative (-).

Loss on Drying When 3 g of Poly- γ -glutamic acid is dried for 3 hours at 105°C, the weight loss should not be more than 4%.

Residue on Ignition When Residue on Ignition analysis is done with accurately weighted 1 g of Poly- γ -glutamic acid, the amount of residue should not be more than 1.0%.

Assay Poly- γ -glutamic acid is dried and 100mg of Poly- γ -glutamic acid is weighted, and dissolved in 10mL water. It is called A solution. 0.5mL of A solution is taken. Add 10mL of 6N hydrochloric acid. Hydrolyze for 24 hours at 110°C to make Test Solution. Calculate the content of glutamic acid by using Amino Acid Analyzer following below condition after taking the appropriate amount of Test Solution.

Separately, the appropriate amount of A solution, which is not hydrolyzed, is taken. Calculate the content of free glutamic acid by using Amino Acid Analyzer. Calculate the content of Poly- γ -glutamic acid following the formula.

$$\text{The content of free glutamic acid (\%)} = \frac{\text{The weight of glutamic acid(g)}}{\text{Weight of sample(g)}} \times 100$$

$$\text{The content of Poly-}\gamma\text{-glutamic acid(\%)} = \frac{\text{The weight of glutamic acid(g)}}{\text{Weight of sample(g)}} \times 0.88 \times 100 - \text{the content of free glutamic acid}$$

$$0.88 = \frac{129(\text{the molecular weight of glutamic acid residue in the Poly-}\gamma\text{-glutamic acid})}{147(\text{the molecular weight of glutamic acid})}$$

Operation condition of Amino Acid Analyzer

Column : HR Na column(4.6mm \times 200mm) or equivalent

Column Temperature : 78°C

Detector and wave length : Spectrophotometer(570nm)

Mobile phase and mobile flow rate

- Buffer solution : Flow Lithium citrate buffer(pH 2.8) with flowing speed of 20mL/h.
- Reaction solution : Flow Ninhydrin solution with flowing speed of 25mL/h.
- Reaction Temperature : 135°C
- The amount of injection : 40 μ l

Solutions

- Ninhydrin solution : 18 g of Ninhydrin and 0.7 g of hydrindantin is precisely weighed and dissolved in 675 mL of dimethylsulfoxide. 225 mL of acetic lithium solution (pH 5.2) is added to the above solution.

ε-Polylysine

Definition ε-Polylysine is obtained by adsorption (with an ion exchange resin), separation, and purification of culture solution of *Streptomyces albulus* (a kind of actinomycetes). Its component is ε-Polylysine.

Compositional Specifications of ε-Polylysine

Content Dried ε-Polylysine should contain no less than 87% of ε-Polylysine.

Description ε-Polylysine is highly hygroscopic pale yellow powder with a slightly bitter taste.

Identification (1) When 1 mL of Dragendorf solution is added to an aqueous solution of ε-Polylysine (0.1→100), reddish brown precipitates are formed.

(2) 0.1 g of ε-Polylysine is dissolved in 100 mL of phosphate buffer solution (pH 6.8). When 1 mL of methyl orange solution is added to 1 mL of this solution, reddish brown precipitates are formed.

Purity (1) Arsenic : It should be no more than 4.0 ppm tested by Arsenic Limit Test.

(2) Lead : When 5.0 g of ε-Polylysine is tested by Atomic Absorption Spectrophotometry or Inductively Coupled Plasma Emission Spectroscopy, its content should not be more than 10.0 ppm.

Loss on Drying When ε-Polylysine is dried for 3 hours at 105°C, the weight loss should not be more than 20%.

Residue on Ignition When thermogravimetric analysis is done with accurately weighted 1 g of ε-Polylysine, the amount of residue should not be more than 1.0%.

Assay (Color Value) Approximately 100 mg of dried ε-Polylysine is precisely weighted and tested by Kjeldahl Method in Nitrogen Determination. The content of ε-Polylysine is obtained by the following equation.

1 mL of 0.1 N sulfuric acid = 1.401 mg N

$$\text{Content(\%)} = \frac{\text{content of nitrogen(mg)} \times 5.24}{A \times \frac{100 - B}{100}} \times 100$$

A : Amount of sample (mg)

B : Loss on Drying (%)

Polysorbate 20

Polyoxyethylene(20) Sorbitan Monolaurate

INS No.: 432

Synonyms: Polyoxyethylene(20) sorbitan monolaurate;
Sorbitan monododecanoate

CAS No.: 9005-64-5

Definition Polysorbate 20 is a partial ester mixture of sorbitol and anhydrous sorbitol with lauric acid, where approximately 20 M of ethylene oxide is bonded to 1 M each of sorbitol, mono or dihydrated form of sorbitol via condensation reaction.

Compositional Specifications of Polysorbate 20

Content Polysorbate 20, when calculated on the dried basis(anhydrous), should contain 70.0~74.0% oxyethylene (C₂H₄O), which corresponds 97.3~103.0% polysorbate 20.

Description Polysorbate 20 is colorless to orange-yellow oily liquid having a slightly characteristic odor.

Identification To 5 mL of Polysorbate 20(1→20), add 5 mL of sodium hydroxide solution and boil for several minutes and cool. When the solution is acidified with dilute acid, it turns white and turbid.

Purity (1) Acid Value : Approximately 10 g of Polysorbate 20 is accurately weighed and dissolved in 125 mL of toluene · isopropyl alcohol mixture (1:1), which is neutralized until it becomes pink with 2 mL of phenolphthalein solution prior to use (heated if necessary). Acid value is calculated from the following equation and should not be more than 2.

(2) Arsenic : It should be no more than 4.0 ppm tested by Arsenic Limit Test.

(3) Lead : When 5.0 g of Polysorbate 20 is tested by Atomic Absorption Spectrophotometry or Inductively Coupled Plasma Emission Spectroscopy, its content should not be more than 2.0 ppm.

(4) Cadmium : When 5.0 g of Polysorbate 20 is tested by Atomic Absorption Spectrophotometry or Inductively Coupled Plasma Emission Spectroscopy, its content should not be more than 1.0 ppm.

(5) Mercury : When Polysorbate 20 is tested by Mercury Limit Test, its content should not be more than 1.0 ppm.

(6) 1,4-Dioxane : To 0.5 g of Polysorbate 20 and 0.1 g of defoamer(containing silicone), add 10 mL of water and diffuse with ultrasonic waves, test solution. Transfer this solution into 25 mL of frit sparger, hold the temperature of container at 50°C, and analyze with Purge and Trap and Gas chromatograph. Separately, to the solution, which 2.5µg of 1,4-Dioxane is contained in 10 mL of water, add 0.1 g of defoamer, standard solution. Analyze the standard solutin in the same manner as the sample (not more than 5.0 ppm).

Operation Condition

Purge and Trap

Trap : Vorcarb 3000 or its equivalent

Purge time : 11 minutes

Desorption temperature and time : 250°C, 4 minutes

Cryo focus temperature : -150°C

Bake temperature and time : 260°C, 10 minutes

Gas chromatography

Column : HP-FFAP(60m × 0.32µm) or its equivalent

Detector : (Hydrogen) Flame Ionization Detector (FID)

Column Temperature : held at 70°C for 5 minutes and is raised to 180°C at a rate of 5°C per minute

Temperature at injection hole : 200°C

Detector Temperature : 250°C

Carrier gas and flow rate : Nitrogen, 0.9 m per minute

(7) Hydroxyl Value : Approximately 3 g of Polysorbate 20 is accurately weighed and transferred into a 250 mL flask with a stopper. Add 5 mL of pyridine-anhydrous acetic acid mixture (3:1), a reflux condenser is attached. It is then heated for 1 hour in a water bath. 10 mL of water is added through the condenser and it is heated again for 10 minutes. After cooling, 15 mL of n-butyl alcohol is added through the condenser, the condenser is removed, and inner wall of the flask is washed with 10 mL of n-butyl alcohol. 1 mL of phenolphthalein solution is added to the flask and the solution is titrated with 0.5 N alcoholic solution of potassium hydroxide. The consumed amount of alcoholic solution is S. Separately, 5 mL of pyridine-anhydrous acetic acid is treated as same as the test solution and the consumed amount of alcoholic solution is B. To correct for free acid, approximately 10 g of Polysorbate 20 is accurately weighed and dissolved in 10 mL of pyridine. After adding 1 mL of phenolphthalein solution, the solution is titrated with 0.5 N alcoholic solution of potassium hydroxide. The consumed amount of alcoholic solution is A. Hydroxyl value, that is calculated by the following equation, should be within a range of 96 ~ 108.

$$\text{Hydroxyl Value} = \frac{[B + (WA / C) - S] \times 28.05}{W}$$

W : Amount of sample used in acetylation (g)

C : Amount of sample used for quantitative analysis of free acid (g)

(8) Saponification Value : Transfer accurately weighed 8 g of Polysorbate 20 into a 250 mL flask and add 50 mL of 0.5 N alcoholic solution of potassium hydroxide. This solution is used as Test solution. When this test solution is proceeded as directed under Saponification Value in Fats Test. The solution is heated to boil and red color reappears. It is titrated again until the color disappears. Saponification value is calculated by the following equation and should be within a range of 40 ~ 50.

(9) Lauric Acid : Approximately 25 g of Polysorbate 20 is accurately weighed and transferred into a 500 mL flask with a stopper and 250 mL of alcohol and 7.5 g of potassium hydroxide are added. A

condenser is attached and the solution is refluxed for 1 ~ 2 hours in a water bath. The resulting solution is transferred into a 800 mL beaker. The flask is washed with 100 mL of water and the wash water is added to the beaker. Alcohol is completely removed by evaporating in a water bath while water is added to supplement the alcohol that is removed. The solution is neutralized with diluted sulfuric acid (1→2) and 10% of the consumed amount is added. The resulting solution is heated while stirring until the fatty acid layer is separated. The fatty acid layer is transferred into a 500 mL separatory funnel with a stopcock. This was washed 3 ~ 4 times with 20 mL of hot water. Wash water is added to the previous aqueous saponified solution. This aqueous solution is extracted 3 times with approximately 50 mL of petroleum ether. Extracted phase is added to the fatty acid layer. This is evaporated to dryness in a container that is previously weighed. The amount of lauric acid should be within a range of 15 ~ 17%. The acid value of lauric acid is tested by the Acid Value in Flavoring Substances Test and should be within a range of 250~275.

Water Content Water content of Polysorbate 20 is determined by back titration method in water determination (Karl-Fisher Titration) and should not be more than 3%.

Residue on Ignition When thermogravimetric analysis is done with 5 g of Polysorbate 20, the amount of residue should not be more than 0.25%.

Assay Experimental apparatus is described below.

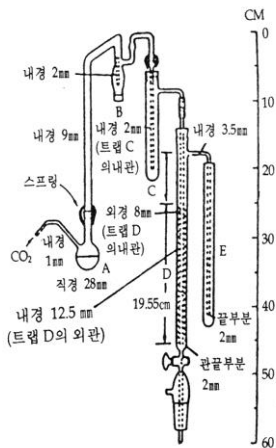

(1) Experiment Apparatus

- A : Distillation flask with a stem through which CO₂ is passed.
- B : A trap connected to air condenser (with red phosphorous suspension)
- C : Absorption tube (with silver nitrate solution to absorb ethyl iodide)
- D : Absorption tube (a spiral glass tube with a diameter of 1.75 mm. 8.5 mm height per 1 revolution. A stopcock is attached at the bottom.)
- E : Trap(with potassium iodide to capture bromine that is pushed out by CO₂)

(2) Solution

Hydroiodic Acid : Hydrogen iodide with the highest purity is dissolved in alkoxy.

Silver nitrate solution : 15 g of silver nitrate is dissolved in 50 mL of water and 400 mL alcohol and a few drops of nitric acid are added.

(3) Experimental Method : 60 mg of red phosphorous is suspended in 100 mL. Trap (B) is filled with enough red phosphorous suspension so that the insertion tube is immersed in the suspension. 10 mL of silver nitrate solution, 15 mL of bromine-bromide solution, 10 mL of potassium iodide solution (1→10) are added to absorption tube (C), absorption tube (D), and trap (E). Approximately 65 mg of Polysorbate 20 is accurately weighed into a reaction flask (A) and 10 mL of hydroiodic acid and glass balls. A condenser is connected and CO₂ is bubbled through at a rate of 1 bubble per second. The flask is heated at 140~145°C in an oil bath at least for 40 minutes. The flask is heated until the reflux in the condenser becomes clear and the supernatant in the tube with silver nitrate solution becomes clear. Before the reaction is complete, olefin is removed by heating the absorption tube (C) 50~60°C for 5 minutes in a water bath. After the reaction is complete, the absorption tubes (D) and (C) are removed in this order and CO₂ connection tube and oil bath are removed. 150 mL of water and 10 mL of potassium iodide solution (1→10) are added to a 500 mL flask, which is then connected to the absorption tube (D). Bromine · bromide solution in the absorption tube (D) is flowed into the flask and the tube and the spiral tube are washed with water. Potassium iodide solution in the trap (E) is transferred into the flask and the tube is washed with water. A stopper is placed on the flask, which is set-aside for 5 minutes. 5 mL of dilute sulfuric acid is added to the flask and the solution is immediately titrated with 0.05 N sodium thiosulfate solution (indicator : starch solution). Separately, a blank test is carried out and the content of oxyethylene as ethylene is calculated by the following equation.

$$\text{Content of oxyethylene(\%)} = \frac{(B - S) \times N \times 2.203}{\text{Weight of the sample(g)}}$$

B : Consumed amount of 0.05 N sodium thiosulfate solution in blank test (mL)

S : Consumed amount of 0.05 N sodium thiosulfate solution in test with sample (mL)

N : Normality of sodium thiosulfate solution

$$\text{Content of oxyethylene group(\%)} = \frac{(B' - S') \times N' \times 4.405}{\text{Weight of the sample(g)}}$$

Silver nitrate solution in the absorption tube (C) is transferred into another flask and the tube is washed with water. 150 mL of water is added to the solution, which is then boiled. After cooling, the solution is titrated with 0.05 N ammonium thiocyanate (indicator : 3 mL of ferric ammonium sulfate solution). Separately, a blank test is carried out in the same manner and the content (%) of oxyethylene (—CH₂CH₂O—) as ethylene iodide (C₂H₅I) is calculated by the following equation.

B' : Consumed amount of 0.05 N ammonium thiocyanate solution in blank test (mL)

S' : Consumed amount of 0.05 N ammonium thiocyanate solution in test with sample

N' : Normality of ammonium thiocyanate solution

The sum of these values is the content of oxyethylene group in the sample.

Polysorbate 60

Polyoxyethylene(20) Sorbitan Monostearate

INS No.: 435

Synonyms: Polyoxyethylene(20) sorbitan
monostearate; Sorbitan monoctadecanoate

CAS No.: 9005-67-8

Definition Polysorbate 60 is a partial ester mixture of sorbitol and anhydrous sorbitol with stearic acid and palmitic acid, where approximately 20 M of ethylene oxide is bonded to 1 M each of sorbitol, mono or dihydrated form of sorbitol via condensation reaction.

Compositional Specifications of Polysorbate 60

Content Polysorbate 60, when calculated on the dried basis(anhydrous), should contain 65.0~69.5% oxyethylene (C₂H₄O), which corresponds 97.3~103.0% polysorbate 60.

Description Polysorbate 60 is colorless to yellow-orange oily liquid or half-gel having a slightly characteristic odor.

Identification (1) to 5 mL of Polysorbate 60 solution (1→20), add 5 mL of sodium hydroxide solution and boil for several minutes and cool. When the solution is acidified with dilute hydrochloric acid, it turns turbid with white color.

(2) A mixture of Polysorbate 60 : water (60:40) forms gel at temperature of 25°C or lower.

Purity (1) Acid value : Acid value of Polysorbate 60 is proceed as directed under Purity (1) for 「Polysorbate 20」. It should not be more than 2.

(2) Arsenic : It should be no more than 4.0 ppm tested by Arsenic Limit Test.

(3) Lead : When 5.0 g of Polysorbate 60 is tested by Atomic Absorption Spectrophotometry or Inductively Coupled Plasma Emission Spectroscopy, its content should not be more than 2.0 ppm.

(4) Cadmium : When 5.0 g of Polysorbate 60 is tested by Atomic Absorption Spectrophotometry or Inductively Coupled Plasma Emission Spectroscopy, its content should not be more than 1.0 ppm.

(5) Mercury : When Polysorbate 60 is tested by Mercury Limit Test, its content should not be more than 1.0 ppm.

(6) 1,4-Dioxan : Proceed as directed under Purity (6) in 「Polysorbate 20」, and its content should not be more than 5.0 ppm.

(7) Hydroxyl Value : Hydroxyl value is obtained by following the Purity (7) for 「Polysorbate 20」 and should be within a range of 81 ~ 96.

(8) Saponification Value : Saponification value is obtained by following the Purity (8) for 「Polysorbate 20」 and should be within a range of 44 ~ 55.

(9) Stearic Acid and Palmitic Acid : The content is obtained by following the Purity (9) for 「Polysorbate 20」 and should be within a range of 21.5~26.0%. The acid value of stearic acid and palmitic acid, as

obtained by the Acid Value Test in Flavoring Substances Test, should be within a range of 200 ~ 212.
Solidification Temperature should not be less than 52°C.

Water Content Water content of Polysorbate 60 is determined by back titration method in water determination (Karl-Fisher Titration) and should not be more than 3%.

Residue on Ignition When thermogravimetric analysis is done with 5 g of Polysorbate 60, the amount of residue should not be more than 0.25%.

Assay Proceed as directed under Assay of 「Polysorbate 20」.

Polysorbate 65

Polyoxyethylene (20) Sorbitan Tristearate

INS No.: 436

Synonyms: Polyoxyethylene(20) sorbitan tristearate

CAS No.: 9005-71-4

Definition Polysorbate 65 is a partial ester mixture of sorbitol and anhydrous sorbitol with stearic acid and palmitic acid, where approximately 20 M of ethylene oxide is bonded to 1 M each of sorbitol, mono or dihydrated form of sorbitol via condensation reaction.

Compositional Specifications of Polysorbate 65

Content Polysorbate 65, when calculated on the dried basis(anhydrous), should contain 46.0~50.0% oxyethylene (C₂H₄O), which corresponds 96.0~104.0% polysorbate 65.

Description Polysorbate 65 is white~yellowish brown solid with slight characteristic scent.

Identification To 5 mL of Polysorbate 65 solution (1→20), add 5 mL of sodium hydroxide solution and boil for several minutes and cool. When the solution is acidified with dilute hydrochloric acid, it turns turbid with white color.

Purity (1) Acid Value : Acid value of Polysorbate 65 is proceed as directed under Purity (1) in 「Polysorbate 20」. It should not be more than 2.

(2) Arsenic : It should be no more than 4.0 ppm tested by Arsenic Limit Test.

(3) Lead : When 5.0 g of Polysorbate 65 is tested by Atomic Absorption Spectrophotometry or Inductively Coupled Plasma Emission Spectroscopy, its content should not be more than 2.0 ppm.

(4) Cadmium : When 5.0 g of Polysorbate 65 is tested by Atomic Absorption Spectrophotometry or Inductively Coupled Plasma Emission Spectroscopy, its content should not be more than 1.0 ppm.

(5) Mercury : When Polysorbate 65 is tested by Mercury Limit Test, its content should not be more than 1.0 ppm.

(6) 1,4-Dioxan : Proceed as directed under Purity (6) in 「Polysorbate 20」, and its content should not be more than 5.0 ppm.

(7) Hydroxyl Value : Hydroxyl value of Polysorbate 65 is proceed as directed under Purity (7) for 「Polysorbate 20」 and should be within a range of 40~60.

(8) Saponification Value : Saponification value of Polysorbate 65 is proceed as directed under Purity (8) in 「Polysorbate 20」 and should be within a range of 88~98.

(9) Stearic Acid and Palmitic Acid : Proceed as directed under Purity (9) for 「Polysorbate 20」. It should be within a range of 42~44%. The acid value of stearic acid and palmitic acid, as obtained by the Acid Value Test in Flavoring Substances Test, should be within a range of 200 ~ 212. The Solidification Temperature should not less than 52°C.

Water Content Water content of Polysorbate 65 is determined by back titration method in water determination (Karl-Fisher Titration) and should not be more than 3%.

Residue on Ignition When thermogravimetric analysis is done with 5 g of Polysorbate 65, the amount of residue should not be more than 0.25%.

Assay Proceed as directed under Assay in 「Polysorbate 20」.

Polysorbate 80

Polyoxyethylene(20) Sorbitan Monooleate

INS No.: 433

Synonyms: Polyoxyethylene(20) sorbitan monooleate; Sorbitan
mono-9-octadecenoate

CAS No.: 9005-65-6

Definition Polysorbate 80 is a partial ester mixture of sorbitol and anhydrous sorbitol with oleic acid, where approximately 20 M of ethylene oxide is bonded to 1 M each of sorbitol, mono or dihydrated form of sorbitol via condensation reaction.

Compositional Specifications of Polysorbate 80

Content Polysorbate 80, when calculated on the dried basis(anhydrous), should contain 65.0~69.5% oxyethylene (C₂H₄O), which corresponds 96.5~103.5% polysorbate 80.

Description Polysorbate 80 is white~orange yellow oily liquid having a slightly characteristic odor.

Identification (1) To 5 mL of Polysorbate 80 solution (1→20), add 5 mL of sodium hydroxide solution and boil for several minutes and cool. When the solution is acidified with dilute hydrochloric acid, it turns turbid with white color.

(2) To 5 mL of Polysorbate 80 solution (1→20), add bromine solution, then bromine' color disappears.

(3) A mixture of Polysorbate 80 : water (60:40) forms gel at temperature of 25°C or lower.

Purity (1) Acid Value : Acid value of Polysorbate 80 is proceed as directed under Purity (1) in 「Polysorbate 20」 and should not be more than 2.

(2) Arsenic : It should be no more than 4.0 ppm tested by Arsenic Limit Test.

(3) Lead : When 5.0 g of Polysorbate 80 is tested by Atomic Absorption Spectrophotometry or Inductively Coupled Plasma Emission Spectroscopy, its content should not be more than 2.0 ppm.

(4) Cadmium : When 5.0 g of Polysorbate 80 is tested by Atomic Absorption Spectrophotometry or Inductively Coupled Plasma Emission Spectroscopy, its content should not be more than 1.0 ppm.

(5) Mercury : When Polysorbate 80 is tested by Mercury Limit Test, its content should not be more than 1.0 ppm.

(6) 1,4-Dioxan : Proceed as directed under Purity (6) in 「Polysorbate 20」, and its content should not be more than 5.0 ppm.

(7) Hydroxyl Value : Hydroxyl value of Polysorbate 80 is proceed as directed under Purity (7) in 「Polysorbate 20」 and should be within a range of 65~80.

(8) Saponification Value : Saponification value of Polysorbate 80 is proceed as directed under Purity (8) in 「Polysorbate 20」 and should be within a range of 45~55.

(9) Oleic Acid : Proceed as directed under Purity (9) for 「Polysorbate 20」. It should be within a range of 22~24%. The acid value of oleic acid, as obtained by the Acid Value Test in Flavoring Substances Test,

should be within a range of 196 ~ 206. Iodine value, as obtained by the following method, should be within a range of 80~92.

Iodine Value : Approximately 0.3 g of Polysorbate 80 is accurately weighed and transferred into a 500 mL Erlenmeyer flask with a stopper and 20 mL of glacial acetic acid/cyclohexane, 1:1, v/v is added to dissolve the material. After adding 25 mL of Weiss solution, a stopper is placed and let stand in the dark for 1 hour where the iodine value is <150 and for 2 hours where the iodine value is ≥150. 20 mL of potassium iodide solution and 100 mL (previously boiled and cooled) are added to the flask. The excess iodine is titrated with 0.1 N sodium thiosulfate solution. Sodium thiosulfate solution is added drop wise until yellow color disappears. Starch solution is added and the titration is continued until the blue color disappears completely. Near the end point, the flask is vigorously shaken with a stopper. Separately, a blank test is carried out by the same procedure.

$$\text{Iodine Value} = \frac{(B - S) \times 1.269}{\text{Weight of the sample(g)}}$$

B : Consumed amount of 0.1 N sodium thiosulfate solution in the blank test (mL)

S : Consumed amount of 0.1 N sodium thiosulfate solution in the test for sample (mL)

Water Content Water content of Polysorbate 80 is determined by back titration method in water determination (Karl-Fisher Titration) and should not be more than 3%.

Residue on Ignition When thermogravimetric analysis is done with 5 g of Polysorbate 80, the amount of residue should not be more than 0.25%.

Assay Proceed as directed under Assay of 「Polysorbate 20」.

Polyvinyl Acetate

Other names: Poly(vinyl acetate)

CAS No.: 9003-20-7

Definition Polyvinyl Acetate is a polymer of vinyl acetate.

Compositional Specifications of Polyvinyl Acetate

Description Polyvinyl Acetate occurs as colorless to light yellow granules or glassy lumps.

Identification Dissolve 1 g of Polyvinyl Acetate in 5 mL of ethyl acetate, and proceed as directed under (5) Thin Film Method in Infrared Spectrophotometry. The solution exhibits absorbances at about 1,725 cm^{-1} , 1,230 cm^{-1} , 1,015 cm^{-1} , 937 cm^{-1} . and 785 cm^{-1} .

Purity (1) Free Acids : Accurately weigh about 2 g of Polyvinyl Acetate, add 50 mL of methanol, and dissolve by shaking occasionally. Add 10 mL of water, and titrate with 0.1 N sodium hydroxide (indicator : 4 ~ 5 drops of phenolphthalein solution). Perform a blank test, and make any necessary correction. Calculate the amount of free acids as acetic acid (CH_3COOH) by the following formula. The content should not be more than 0.05%.

Content of free acids (%) =

$$\frac{\text{volume of 0.1N sodium hydroxide consumed(mL)} \times 60}{\text{weight of the sample(g)} \times 10 \times 1,000} \times 100$$

(2) Arsenic : It should be no more than 4.0 ppm tested by Arsenic Limit Test.

(3) Lead : When 5.0 g of Polyvinyl Acetate is tested by Atomic Absorption Spectrophotometry or Inductively Coupled Plasma Emission Spectroscopy, its content should not be more than 3.0 ppm.

(4) Polyvinyl Acetate : Finely crush the sample. Accurately weigh 2.5 g of the sample, transfer into 25mL volumetric flask, and dissolve in toluene to make 25 mL, test solution. The test solution is proceeded gas chromatography under operation conditions below and measure the amount of polyvinyl acetate from calibration curve. Its content should not be more than 5 ppm.

Standard solution : Accurately weigh 0.05 g of polyvinyl acetate, transfer into a 50mL volumetric flask and dilute to 50 mL with toluene. Accurately pipette 0.01, 0.03, 0.1, 0.3, and 1mL of this stock solution into each flask to make 100 mL, standard solution.

Standard Curve Preparation : Standard solutions of 5 different concentration is proceeded gas chromatography under operation conditions below and prepare standard curve.

Operation Condition

Column : HP-1(30m×0.32mm, 0.25µm) or its equivalent

Detector : Hydrogen Flame Ionization Detector (FID)

Temperature at injection hole: 150°C

Amount of injection : 1µl

Column Temperature : Keeping at 100°C for 8 minutes, it is raised as the rate of 20°C/minutes by 250°C, keep at 250°C for 5 minutes

Carrier gas : helium

Loss on Drying When Polyvinyl Acetate is dried at 80°C for 3 hours under a reduced pressure, the weight loss should not be more than 1%.

Residue on Ignition When thermogravimetric analysis is done with 2 g of Polyvinyl Acetate, the residues should not be more than 0.05%.

Polyvinyl Alcohol

INS No.: 1203

Synonyms: Ethenol homopolymer; PVOH; Vinyl alcohol polymer

CAS No.: 9002-89-5

Definition Polyvinyl Alcohol is polymer(ester of polyvinyl is partly hydrolyzed).

Compositional Specifications of Polyvinyl Alcohol

Description Polyvinyl Alcohol is odorless as a white~pale yellow powder or granule.

Identification

- (1) Polyvinyl Alcohol is soluble in water and Polyvinyl Alcohol is insoluble in ethanol.
- (2) pH of Polyvinyl Alcohol solution(1→25) should be 5.0~6.5.
- (3) When Polyvinyl Alcohol is proceeded as directed under (1) potassium bromide disk method in Infrared Spectrophotometry, the maximum absorption should appear at the same wavelength as a Polyvinyl Alcohol standard.
- (4) After dissolving 0.01 g of Polyvinyl Alcohol in 100 mL of water, heat and cool it at room temperature. Add 1 drop of iodine solution and a few drops of boric acid to 5 mL of this solution and wait. And then the color shows blue.
- (5) After dissolving 0.5 g of Polyvinyl Alcohol in 10 mL of water, heat and cool it at room temperature. Add 1 drop of iodine solution to 5 mL of this solution and wait. And then the color shows dark red~blue.
- (6) When add 10 mL of ethanol to 5 mL of the rest solution (5), a white precipitation is generated.

Purity (1) Water Insoluble Substances : 10 g of Polyvinyl Alcohol, accurately weighed, is dissolved in 100 mL of hot water. Insoluble substances are separated by a glass filter (100 mesh screen) and washed with 30 mL of hot water. The glass filter is dried for 2 hours at 105°C. The amount of insoluble substances should not be more than 0.1%.

- (2) Particles Size : Take 100 g of Polyvinyl Alcohol and measure amount of passing through sieve of 100 mesh. The amount should be more than 99.0%.
- (3) Lead : When 5.0 g of Polyvinyl Alcohol is tested by Atomic Absorption Spectrophotometry or Inductively Coupled Plasma Emission Spectroscopy, its content should not be more than 2.0 ppm.
- (4) Methanol and Methyl acetate : 2.0 g of Polyvinyl Alcohol is accurately weighed into a 100 mL glass bottle with stopper, 98mL of water and 30 μ l of acetone are added. After the stopper is placed to bottle, mix it continually with boiling in water bath. When the solution is clear, take it out of the water bath and cool it at room temperature. This solution is used as test solution. Separately, make each concentration of methanol and methyl acetate to 1.2%(v/v). Take 2 mL of this solution and add 98mL of water and 30 μ l of acetone. Make solution by the above same method on making test solution. This solution is used as standard solution(1 mL of this solution contains 0.24 μ l of methanol and 0.24 μ l of

methyl acetate). Inject respectively each 0.4 μ l of methanol and methyl acetate to gas chromatography under below operation conditions. The content of methanol and methyl acetate are calculated by following formula, the content should not be more than 1.0% respectively.

$$\begin{aligned} \text{Content of Methanol(\%)} &= \frac{Q_{T2}}{Q_{T1}} \times \frac{Q_{S1}}{Q_{S2}} \times 0.024 \times \frac{100}{\text{Weight of sample(g)}} \\ \text{Content of Methyl acetate(\%)} &= \frac{Q_{T2}}{Q_{T1}} \times \frac{Q_{S1}}{Q_{S2}} \times 0.024 \times \frac{100}{\text{Weight of sample(g)}} \end{aligned}$$

Q_{T1} : Peak area of acetone of test solution

Q_{T2} : Peak area of methanol of test solution

Q_{T2} : Peak area of methyl acetate of test solution

Q_{S1} : Peak area of acetone of standard solution

Q_{S2} : Peak area of methanol of standard solution

Q_{S2} : Peak area of methyl acetate of standard solution

Operation Conditions

Column : PLOT Q or its equivalent

Detector : Hydrogen Flame Ionization Detector (FID)

Temperature at injection hole: 160°C

Column Temperature : 160°C

Detector Temperature : 160°C

Carrier gas and flow rate : Nitrogen

- (5) Acid value : 3 g of Polyvinyl Alcohol is precisely weighted and taken into round bottom flask and dissolved in 250 mL of water. Put a magnetic bar into flask and attach a reflux condenser. Boil it in water bath for 30 minutes with mixing and cool it. 50 mL of this solution is used as test solution. When test solution is tested by Acid Value Test Methods in Flavoring Substances Test, the value should be not more than 3.
- (6) Ester value : 1 g of Polyvinyl Alcohol is precisely weighted and 25mL of 0.5 N alcoholic potassium hydroxide and 25 mL of water are added into 250 mL round bottom flask. A reflux condenser is attached and the solution is heated for 30 minutes in a water bath. Cool it and add 1 mL of phenolphthalein solution. Excess alkali is titrated with 0.5 N hydrochloric acid and ester value is calculated by the following equation. Ester value should be 125 ~ 153. Separately, a blank test is carried out.

$$\text{Saponification Value} = \frac{(a-b) \times 28.05}{\text{Weight of sample(g)}}$$

a : Consumed amount of 0.5 N hydrochloric acid for blank test (mL)

b : Consumed amount of 0.5 N hydrochloric acid for Test Solution (mL)

(7) Degree of Hydrolysis : Saponification Value(S_d) of the above (6) is calculated on the dried basis. And calculate degree of hydrolysis is calculated by following formula, the value should be 86.5~89.0%.

$$\text{Saponification Value (calculated on the dried basis, } S_d) = \frac{\text{Saponification Value} \times 100}{\text{Weight of sample(g)}}$$

$$\text{Degree of Hydrolysis (\%)} = 100 - \frac{7.84 \times S_d}{100 - (0.075 \times S_d)}$$

(8) Viscosity : After drying Polyvinyl Alcohol, take precisely 6.0 g. Put it into 250 mL flask and add water of 140 mL and mix it with using a magnetic bar. When the solution is completely saturated, increase speed of stirring. After removing the effervescence, heat it by 90°C and keep it 5 minutes. And then stop heating and stir it for 1 hour. After adding a little water to make precisely 150 g, stir it to make this solution homogeneous. And cool it until the temperature of solution is about 15°C. When the viscosity is measured by Method 1 Capillary Viscosity Measurement in Viscosity at 20±0.1°C, it should be 4.8 ~ 5.8cps.

Loss on Drying When Polyvinyl Alcohol is dried for 3 hours at 150°C, the weight loss should not be more than 5.0%.

Residue on Ignition When thermogravimetric analysis is done with Polyvinyl Alcohol, the residue should not be more than 0.1%.

Polyvinyl Polypyrrolidone

INS No.: 1202

Synonyms: Insoluble polyvinylpolypyrrolidone;
Crosprovidone; Cross linked polyvidone

CAS No.: 25249-54-1

Compositional Specifications of Polyvinyl Polypyrrolidone

Description Polyvinyl Polypyrrolidone is white ~ pale yellow-white powder. It is odorless.

Identification When to 1 g of Polyvinyl Polypyrrolidone, add 10 mL of water and 0.1 mL of iodine solution and shake for 30 seconds, the suspension decolorizes. When add 1 mL of starch solution and shake, the suspension should not become blue.

Purity (1) pH : When 1 g of Polyvinyl Polypyrrolidone, add water to make 100 mL, pH of the solution should be within a range of 5.0~11.0.

(2) Water Solubles : Approximately 25.0 g of Polyvinyl Polypyrrolidone is precisely weighed and transferred into a distillation flask. 225 mL of water is added and a reflux condenser is attached to the flask. While mixing with a stirrer, the flask is heated for 20 hours. After cooling, the suspension is transferred into a 250 mL volumetric flask, set-aside for 15 minutes and the supernatant is centrifuged for 1 hour at 12,000 rpm. The resulting supernatant is filtered through a membrane filter with 0.45 μ m pore size. 50 mL of filtrate is precisely taken onto a glass evaporation dish, which is weighed prior to use. Then the filtrate is evaporated to dryness and further dried for 3 hours at 90°C. It is then cooled in a desiccator and precisely weighed. The content of residue should not be more than 1.5%.

(3) Nitrogen : Transfer 100 mg of Polyvinyl Polypyrrolidone into a flask for decomposition. Add 1 g of potassium sulfate and copper sulfate mixture (10:1), inner wall of the flask, and wash with small amount of water. Add 7 mL of sulfuric acid and shake, and slowly add 1 mL of 30% hydrogen peroxide. Then the content is decomposed by heating until it becomes transparent and blue. After the decomposition is over, the liquid is cooled, where 20 mL of water is added use the Test Solution. The Test Solution is quantitatively analyzed for nitrogen. The content of nitrogen should be within a range of 11.0 ~ 12.8%.

(4) Lead : When 5.0 g of Polyvinyl Polypyrrolidone is tested by Atomic Absorption Spectrophotometry or Inductively Coupled Plasma Emission Spectroscopy, its content should not be more than 2.0 ppm.

(5) Zinc : When 5.0 g of Polyvinyl Polypyrrolidone is tested by Atomic Absorption Spectrophotometry or Inductively Coupled Plasma Emission Spectroscopy, its content should not be more than 25 ppm.

(6) N-Vinyl Pyrrolidone : Accurately weigh 4 g of the sample, add 30 mL of water, and stir it for 15 minutes. Transfer the solution into a centrifuge tube and wash the residue with 20 mL of water. Combine the washings and the filtrate, and centrifuge it. Filter supernatant with glass filter (1G4 or its equivalent), wash the residue 50 mL of water and, combine it to the filtrate. Add 0.5 g of sodium acetate, mix and begin titrating with 0.1N iodine. When the iodine colour no longer fades, add

additional 3 mL of the titrate, and allow the solution to stand for 10 minutes. Titrate the excess iodine with 0.1 N sodium thiosulfate solution, and the consumed amount of 0.1N iodine solution should not exceed 0.72 mL. Separately, a blank test is carried out (not more than 0.1%).

1 mL of 0.1 N iodine solution = 5.56mg of N-vinyl pyrrolidone

(7) Unsaturated Matter : To 4 g of Polyvinyl Polypyrrolidone, add 30 mL of water and stirrer for 15 minutes. This is filtered through a glass filter into a 250 mL Erlenmeyer flask. Residue on the filter is washed with 100 mL of water and the rinse water is added to the filtrate. 0.5 g of sodium acetate is added to the resulting solution, which is then titrated with 0.1 N iodine solution until the color doesn't get lighter. After adding 3 mL of 0.1 N iodine solution is added, the solution is set-aside for 10 minutes. Excess iodine is titrated with 0.1 N sodium thiosulfate solution (indicator : starch solution). Separately, a blank test is carried out following the same procedure and the content is calculated by the following equation. The content of unsaturated matter should not be more than 0.1%.

$$\text{Content of unsaturated matter(\%)} = \frac{(b - a) \times N \times 0.0555}{\text{weight of the sample(g)}} \times 100$$

a : Consumed amount of 0.1 N sodium thiosulfate for the test solution (mL)

b : Consumed amount of 0.1 N sodium thiosulfate for the blank test (mL)

N : Normality of 0.1 N sodium thiosulfate solution

Water Content Water content of Polyvinyl Polypyrrolidone is determined by water determination (Karl-Fisher Titration) and should not be more than 6%.

Residue on Ignition Residue on ignition of Polyvinyl Polypyrrolidone should not be more than 0.4%.

Polyvinyl Pyrrolidone

Povidone

INS No.: 1201

Synonyms: Soluble polyvinylpyrrolidone; Povidone;
PVP

CAS No.: 9003-39-8

Compositional Specifications of Polyvinyl Pyrrolidone

Description Polyvinyl Pyrrolidone is white ~ yellowish brown powder.

Identification (1) When 20 mL of 1 N hydrochloric acid and 5 mL potassium bichromate solution are added to 10 mL of an aqueous solution (1→50) of Polyvinyl Pyrrolidone, orange colored precipitates are formed.

(2) 75 mg of cobalt nitrate and 0.3 g of ammonium thiocyanate are dissolved in 2 mL of water, which is mixed with 5 mL aqueous solution (1→50) of Polyvinyl Pyrrolidone. When the resulting solution is acidified with dilute hydrochloric acid, pale blue precipitates are formed.

Purity (1) pH : A suspension of 5 g of Polyvinyl Pyrrolidone in 100 mL of water should have a pH range of 3.0~5.0

(2) Lead : When 5.0 g of Polyvinyl Pyrrolidone is tested by Atomic Absorption Spectrophotometry or Inductively Coupled Plasma Emission Spectroscopy, its content should not be more than 2.0 ppm.

(3) Aldehyde : 10 g of Polyvinyl Pyrrolidone is precisely weighed and dissolved in 300 mL of water, where 80 mL of 25% sulfuric acid is added. The solution is transferred into a 1000 mL round bottom flask. It is then extracted for 45 minutes with a reflux condenser. It is then distilled 100 mL with 20 mL of 1 N hydroxylamine chloride salt solution whose pH is adjusted to 3.1. It is then titrated with 0.1 N sodium hydroxide solution to pH 3.1 using a pH meter. Separately, a blank test is carried out.

1 mL of 0.1 N of sodium hydroxide solution = 4.405 mg C_2H_4O

(4) Hydrazine : 2.5 g of Polyvinyl Pyrrolidone transfer into a 50 mL centrifuge tube and dissolved in 25 mL of water, where 500 μ L of salicylaldehyde solution in methanol (1→20) and shaken. The tube is heated for 15 minutes at 60°C in a water bath. After cooling, 2.0 mL of toluene is added to the tube, which is shaken vigorously for 2 minutes and then centrifuged. The supernatant is collected (Test Solution). 10 μ L of each of Test Solution and previously prepared salicylaldazine standard solution is spotted on thin layer chromatography plate. The plate is absorbed with silica gel that is silanized with dimethylsilane. Using a mixture of methanol : water (2:1) as a Mobile Phase, it is developed to 3/4 position and dried in air, which is then observed under 365 nm UV light. The spot of Test Solution should not be darker than that of Standard Solution (not more than 1 ppm).

• Salicyl Aldazine Standard Solution : 300 mg of hydrazine sulfate is dissolved in 5 mL of water, where 1 mL of anhydrous acetic acid and freshly prepared 20% salicyl aldehyde solution in isopropyl alcohol. It is then set aside until yellow precipitates are formed. This is then extracted with 15 mL of methyl chloride. Methylene chloride is completely removed by evaporation. A mixture of warm toluene and methanol (60:40) is added to the precipitates, which is then cooled to recrystallize. It is then filtered and dried under vacuum. Melting point should be within a range of 213 ~ 219°C and the difference in temperature between beginning and end of melting should not be exceed 1°C. The Standard Solution contains 9.38 µg/mL of toluene.

(5) Relative Viscosity : Approximately 1 g of dried material is precisely weighed and dissolved in 50 mL of water and the total volume is brought to 100 mL with water. After settling for 1 hour, it is filtered (Test Solution). An Abbe viscometer is previously cleaned, dried and maintained at $25 \pm 0.2^\circ\text{C}$ in a water bath. 10 mL of the Test Solution transfer into the viscometer, heated for 10 minutes in a water bath. The upper layer of the Test Solution is gently sucked into the capillary exactly above the upper scale mark. After relieving suction, when the meniscus of the Test Solution reaches the upper scale mark, the flow time through the capillary is clocked. Time taken for the Solution to travel from the upper scale mark to the lower scale mark is measured. This procedure is repeated three times and an average value (to one decimal point) is calculated. If the range of time measured exceeds 0.3 second, the viscometer is cleanly washed and the experiment is repeated with 10 mL of Test Solution. A blank test is carried out with water. Relative viscosity is calculated by dividing the time for Test Solution by the time for blank test [1.188~1.325 (molecular weight about 40,000), 3.225~5.662 (molecular weight about 360,000)].

(6) Monomer : Approximately 4 g is precisely weighed into a flask with a stopper and dissolved in 30 mL of water. While mixing with 0.5 g of sodium acetate, the solution is titrated with 0.1 N iodine solution. When the color of the iodine doesn't change, 3.0 mL of iodine solution is added. After setting aside for 5 ~ 10 minutes, the excess iodine is titrated with 0.1 N sodium thiosulfate solution (indicator : starch solution). A blank test is carried out with the same amount of 0.1 N iodine solution.

$$1 \text{ mL of Iodine solution } 0.1 \text{ N} = 5.56 \text{ mg } \text{C}_6\text{H}_9\text{NO}$$

(7) Nitrogen : 0.1 g of Polyvinyl Pyrrolidone is added to a flask for decomposition. After adding 1 g of potassium sulfate and copper sulfate mixture (1:1), inner wall of the flask is washed with small amount of water. 7 mL of sulfuric acid is added. While shaking, 1 mL of 30% hydrogen peroxide is slowly added. Then the content is decomposed by heating until it becomes transparent blue liquid. After the decomposition is over, the liquid is cooled, where 20 mL of water is added (Test Solution). The Test Solution is quantitatively analyzed for nitrogen. The content of nitrogen should be within a range of 12.2 ~ 13.0%.

Water Content Water content of Polyvinyl Pyrrolidone is determined by water determination (Karl-Fisher

Titration) and should not be more than 5.0%.

Potassium Alginate

Chemical Formula: $(C_6H_7O_6K)_n$

Equiv wt, actual(avg.): 238.00

INS No.: 402

Synonyms: Potassium salt of alginate

CAS No.: 9005-36-1

Compositional Specifications of Potassium Alginate

Content If Potassium Alginate, when calculated on the dried basis, should contain 16.5~19.5% carbon dioxide (CO_2), which corresponds to 89.2~105.5% potassium alginate.

Description Potassium Alginate occurs as white ~ pale yellow fiber, granule, or powder.

Identification (1) Proceed as directed under Identification (1) for 「Ammonium Alginate」.

(2) Proceed as directed under Identification (2) for 「Ammonium Alginate」.

(3) Proceed as directed under Identification (3) for 「Alginic Acid」.

Purity (1) Arsenic : It should be no more than 4.0 ppm tested by Arsenic Limit Test.

(2) Lead : When 5.0 g of Potassium Alginate is tested by Atomic Absorption Spectrophotometry or Inductively Coupled Plasma Emission Spectroscopy, its content should not be more than 5.0 ppm.

(3) Cadmium : When 5.0 g of Potassium Alginate is tested by Atomic Absorption Spectrophotometry or Inductively Coupled Plasma Emission Spectroscopy, its content should not be more than 1.0 ppm.

(4) Mercury : When Potassium Alginate is tested by Mercury Limit Test, its content should not be more than 1.0 ppm.

(5) Total Viable Aerobic Count : When Potassium Alginate is tested by Microbe Test Methods for Total Viable Aerobic Count (Number of General Germs) in General Test Method in 「Standards and Specifications for Foods」, it should not be more than 5,000 per 1 g

(6) E. coli : When Potassium Alginate is tested by Microbe Test Methods for E. coli in General Test Method 「Standards and Specifications for Foods」, it should be negative (-).

(7) Salmonella : When Potassium Alginate is tested by Microbe Test Methods for Salmonella in General Test Method 「Standards and Specifications for Foods」, it should be negative (-).

(8) Fungi : When Potassium Alginate is tested by Microbe Test Methods for Fungi in General Test Method in 「Standards and Specifications for Foods」, it should not be more than 500 per 1 g

Loss on Drying When 3 g of Potassium Alginate is dried for 4 hours at 105°C, the loss should not be more than 15.0%.

Assay Approximately 0.25 g of Potassium Alginate is precisely weighed and analyzed by the procedure in Content Analysis for [Xanthan Gum].

1 mL of 0.25 N sodium hydroxide solution = 28.75 mg Potassium alginate
(Equivalent Value : 238.00)

Potassium Benzoate

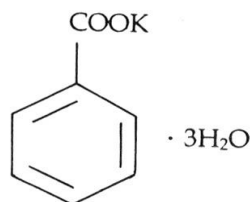

Chemical Formula: C₇H₅KO₂·3H₂O

Molecular Weight: 214.27

INS No.: 212

Synonyms: Potassium salt of benzenecarboxylic acid

CAS No.: 582-25-2

Compositional Specifications of Potassium Benzoate

Content Potassium Benzoate, when calculated on the dried basis, should contain not less than 99.0% of potassium benzoate (C₇H₅KO₂).

Description Potassium Benzoate is scentless white grain, crumb, or crystalline powder.

Identification Potassium Benzoate responds to test of Benzoate or Potassium Salts in Identification.

Purity (1) Melting Point : 2% aqueous solution of Potassium Benzoate is acidified with dilute hydrochloric acid. Precipitates are filtered, washed with water, and dried for 4 hours at 105°C. The melting point should be within a range of 121.5~123.5°C.

(2) Free Acid and Free Alkali : 2 g of Potassium Benzoate is precisely weighed and dissolved in 20 mL of hot water. After adding 2 ~ 3 drops of phenolphthalein solution, the solution is titrated with 0.1 N sodium hydroxide solution or 0.1 N of hydrochloric acid. The consumed amount of the solution should not exceed 0.5 mL.

(3) Chlorinated Compounds : 0.25 g of potassium benzoate is dissolved in 10 mL of water, which is acidified with nitric acid. The precipitates are filtered, mixed with 0.5 g potassium carbonate, and dried. The mixture is then heat treated for approximately 10 minutes at 600°C. After cooling, the residue is dissolved in 20 mL of dilute nitric acid and filtered. 0.5 mL of 0.1 N silver nitrate is added to the filtrate (Test Solution). Separately, water is added to a mixture of 0.5 mL of 0.1 N silver nitrate solution and 0.5 mL of 0.01 N hydrochloric acid so that the concentration is the same as in Test Solution. This solution as the reference solution. Turbidity of the Test Solution should be equal to or less than that of the Reference Solution.

(4) Arsenic : It should be no more than 4.0 ppm tested by Arsenic Limit Test.

(5) Lead : When 5.0 g of potassium benzoate is tested by Atomic Absorption Spectrophotometry or Inductively Coupled Plasma Emission Spectroscopy, its content should not be more than 2.0 ppm.

(6) Mercury : When potassium benzoate is tested by Mercury Limit Test, its content should not be more

than 1.0 ppm.

(7) Readily Oxidizable Matters : Add 1.5 mL of sulfuric acid to 100 mL of water, add drop wise 0.1 N potassium benzoate while boiling until the pink color persists for 30 seconds. Weigh 1 g of Sodium Benzoate, and dissolve in the solution. Titrate with 0.1 N potassium permanganate at about 70°C until the pink color persists for 15 seconds. The amount should not be more than 0.5 mL.

(8) Readily Carbonizable Substances : When 0.5 g of potassium benzoate is tested for Readily Carbonizable Substances, its color should not be darker than the color standard solution Q.

Loss on Drying When Potassium Benzoate is dried for 4 hours at 105°C, the loss should not be more than 26.5%.

Assay 2.5 ~ 3 g of Potassium Benzoate, precisely dried at 105°C until the weight becomes constant, and accurately weighed, dissolve in 50 mL of water. The solution is neutralized with 0.1 N hydrochloric acid (using phenolphthalein solution as an indicator, if necessary). 50 mL of ether and 3 ~ 5 drops of bromophenol blue solution are added. While shaking so that ether layer and aqueous layer are well mixed, the mixture is titrated with 0.5 N hydrochloric acid. The aqueous layer is separated out and the ether layer is washed with 10 mL of water. Wash water is added to the previous aqueous layer. With 20 mL of ether, the aqueous phase is titrated again by the same procedure.

1 mL of 0.5 N hydrochloric acid = 80.11 mg $C_7H_5KO_2$

Potassium Bicarbonate

Chemical Formula: KHCO_3

Molecular Weight: 100.12

INS No.: 501(ii)

Synonyms: Potassium hydrogen carbonate; Acid
potassium carbonate

CAS No.: 298-14-6

Compositional Specifications of Potassium Bicarbonate

Content Potassium Bicarbonate, when calculated on the dried basis, should contain within a range of 99.0~101.5% of potassium bicarbonate (KHCO_3).

Description Potassium Bicarbonate is colorless transparent crystalline or white platelet powder.

Identification Potassium Bicarbonate solution (1→10) responds to test of potassium salts and bicarbonates in Identification.

Purity (1) Lead : Potassium Bicarbonate is precisely weighed and is tested by purity (2) for 「Sodium Metaphosphate」, its content should not be more than 2.0 ppm.

(2) Arsenic : It should be no more than 4.0 ppm tested by Arsenic Limit Test.

(3) Mercury : When Potassium Bicarbonate is tested by Mercury Limit Test, its content should not be more than 1.0 ppm.

(4) Carbonates : 1 g of Potassium Bicarbonate is dissolved in 20 mL of water at temperature of 5°C or lower without shaking. After adding 2 mL of 0.1 N hydrochloric acid and 2 drops of phenolphthalein solution, the color of the solution should not be deeper than pale red.

Loss on Drying When Potassium Bicarbonate is dried for 4 hours in a desiccator (silica gel), the loss should not be more than 0.25%.

Assay Approximately 4 g of Potassium Bicarbonate is precisely weighed and dissolved in 100 mL of water. After adding 2 drops of methyl red solution, the solution is titrated with 1 N hydrochloric acid while stirring until the color turns pale red. Near the end point, the solution is boiled and then cooled. Titration is continued until the color of the solution doesn't become pale.

1 mL of 1 N hydrochloric acid = 100.1 mg KHCO_3

Potassium DL-Bitartrate

Potassium Hydrogen DL-Tartrate

C
C
C
K
□
C
H
C
H
□
C
H
C
H
□
C
C
C
H
C
h
e
m
i
c
a
l
F
o
r
m
u
l
a
:

C
4
H
5
O
6
K
M
o
l
e
c
u
l
a
r
W
e
i
g
h
t
:
1
8
8
.
1
8

Compositional Specifications of Potassium DL-Bitartrate

Content Potassium DL-Bitartrate, when calculated on the dried basis, should contain within a range of 99.0 ~ 101.0% of potassium DL-bitartrate ($C_4H_5O_6K$).

Description Potassium DL-Bitartrate occurs as colorless crystals or as a white crystalline powder, having a cool, acid taste.

Identification (1) Dissolve 1 g of Potassium DL-Bitartrate in 10 mL of ammonia solution. The solution

has no optical activity.

(2) Proceed as directed under Identification (2) and (3) in Potassium L-Bitarate.

Purity (1) Clarity and Color of Solution, Sulfate, Ammonium salt : Proceed as directed under Purity (1), (3), and (4) for [Potassium L-Bitarate].

(2) Arsenic : It should be no more than 4.0 ppm tested by Arsenic Limit Test.

(3) Heavy Metals : Proceed as directed under Purity (6) for [Potassium L-Bitarate].

(4) Readily Oxidizable Substances : Weigh 2.0 g of Potassium DL-Bitartrate, dissolve in 20 mL of water and 30 mL of diluted sulfuric acid. keep the temperature at 20°C, and add 4.0 mL of 0.1 N potassium permanganate. The pink color of the solution does not disappear within 3 minutes.

Loss on Drying When Potassium DL-Bitartrate is dried for 3 hours at 105°C, the weight loss should not be more than 0.5%.

Assay Proceed as directed under Assay for [Potassium L-Bitarate].

Potassium L-Bitartrate

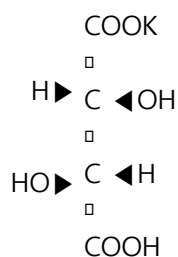

Chemical Formula: $\text{C}_4\text{H}_5\text{O}_6\text{K}$

Molecular Weight: 188.18

INS No.: 336(i)

Synonyms: Monobasic potassium tartrate

CAS No.: 868-14-4

Compositional Specifications of Potassium L-Bitartrate

Content Potassium L-Bitartrate, when calculated on the dried basis, should contain within a range of 99.0 ~ 101.0% of potassium L-bitartrate ($\text{C}_4\text{H}_5\text{O}_6\text{K}$).

Description Potassium L-Bitartrate occurs as colorless crystals or as a white crystalline powder, having a cool, acid taste.

Identification (1) Dissolve 1 g of Potassium L-Bitartrate in 10 mL of ammonia solution. The solution is dextrorotatory.

(2) Heat gradually 0.5 g of Potassium L-Bitartrate. A burning sucrose-like odor is evolved, and carbonization occurs. To the residue, add 5 mL of water, and stir well. The solution is alkaline. Neutralize the solution with diluted hydrochloric acid, and filter. The solution responds to the test for Potassium Salt.

(3) Potassium L-Bitartrate responds to the test for Tartrate in Identification.

Purity (1) Clarity and Color of Solution : 0.5 g of Potassium L-Bitartrate is dissolved. 3 mL of ammonia solution. It is Colorless and almost clear.

(2) Specific Rotation : After drying for 3 hours at 105°C , approximately 5g of Potassium L-Bitartrate is precisely weighed, which is dissolved in 10 mL of ammonia solution and water so that the total volume becomes 50 mL. Optical rotation of this solution should be within a range of $[\alpha]_D^{20} = +32.5 \sim +35.5^\circ$

(3) Sulfate : 0.5 g of Potassium L-Bitartrate is dissolved in a warm mixture of 2 mL hydrochloric acid and 30 mL of water. After cooling, the solution is tested by Sulfate Limit Test, its content should not be more than the amount that corresponds to 2 mL of 0.01 N sulfuric acid.

(4) Ammonium Salt : Weigh 0.5 g of Potassium L-Bitartrate, add 5 mL of sodium hydroxide solution, and heat. No odor of ammonia is evolved.

(5) Arsenic : It should be no more than 4.0 ppm tested by Arsenic Limit Test.

(6) Lead : When 5.0 g of Cinnamic Acid is tested by Atomic Absorption Spectrophotometry or Inductively Coupled Plasma Emission Spectroscopy, its content should not be more than 2.0 ppm.

(7) Insoluble materials: Weight 1 g of Potassium L-Bitartrate, and dissolve in 3 mL of ammonia water. Insoluble materials should not be left in this solution.

Loss on Drying When Potassium L-Bitartrate is dried for 3 hours at 105°C, the loss should not be more than 0.5%.

Assay Dissolve 0.4 g of Potassium L-Bitartrate, previously dried and accurately weighed in 20 mL of hot water, and titrate with 0.1 N sodium hydroxide while hot (indicator : 2 ~ 3 drops of phenolphthalein solution).

1 mL of 0.1 N sodium hydroxide = 18.82 mg of $C_4H_5O_6K$

Potassium Carbonate, Anhydrous

Chemical Formula: K_2CO_3

INS No.: 501(i)

Molecular Weight: 138.21

CAS No.: 584-08-7

Compositional Specifications of Potassium Carbonate

Content Potassium Carbonate (Anhydrous), when calculated on the dried basis, should be contain not less than 99.0% of potassium carbonate (K_2CO_3).

Description Potassium Carbonate (Anhydrous) occurs as white powder or granules.

Identification Potassium Carbonate solution (1→10) responds to the tests for Potassium salt and Carbonate in Identification.

Purity (1) Clarity and Color of Solution : When 1 g of Potassium Carbonate (Anhydrous) is dissolved in 20 mL of water, the solution should be colorless and almost clear.

(2) Chloride : Weigh 0.2 g of Potassium Carbonate (Anhydrous), add 6 mL of diluted nitric acid, boil, cool and add 6 mL of diluted nitric acid, Test Solution. This Test Solution is tested by Chloride Limit Test and its content should not be more than the amount that corresponds to 0.3 mL of 0.01 N hydrochloric acid.

(3) Arsenic : It should be no more than 4.0 ppm tested by Arsenic Limit Test.

(4) Lead : Potassium Carbonate (Anhydrous) is tested by purity (2) for 「Sodium Metaphosphate」(not more than 2.0 ppm).

(5) Mercury : When Potassium Carbonate (Anhydrous) is tested by Mercury Limit Test, its content should not be more than 1.0 ppm.

Loss on Drying When Potassium Carbonate, Anhydrous is dried for 4 hours at 180°C, the weight loss should not be more than 1%.

Assay Accurately weigh about 1 g of Potassium Carbonate Anhydrous, previously dried, dissolved in 25 mL of water, and titrate with 0.5 N sulfuric acid (indicator: 3 drops of bromophenol blue solution). Boil near the end point to expel carbon dioxide, cool, and continue the titration.

1 mL of 0.5 N sulfuric acid = 34.55 mg of K_2CO_3

Potassium Chloride

Chemical Formula: KCl

Molecular Weight: 74.56

INS No.: 508

Synonyms: Sylvine; Sylvite

CAS No.: 7447-40-7

Compositional Specifications of Potassium Chloride

Content Potassium Chloride, when calculated on the dried basis, should contain not less than 99.0% of potassium chloride (KCl).

Description Potassium Chloride occurs as colorless crystals or as a white powder. It is odorless and has a salty taste.

Identification Potassium Chloride solution(1→20) responds to the tests for Potassium Salt and Chloride in Identification.

Purity (1) Free Acid and Free Alkali : Weigh 5 g of Potassium Chloride, dissolve in 50 mL of freshly boiled and cooled water, and add 3 drops of phenolphthalein solution. The color of the solution does not change to pink. Add 0.3 mL of 0.02 N sodium hydroxide. The color of the solution changes to pink.

(2) Arsenic : It should be no more than 4.0 ppm tested by Arsenic Limit Test.

(3) Lead : Potassium Chloride is tested by purity (2) for 「Sodium Metaphosphate」(not more than 2.0 ppm).

(4) Cadmium : Potassium Chloride is tested by purity (3) for 「Sodium Metaphosphate」(not more than 1.0 ppm).

(5) Mercury : When Potassium Chloride is tested by Mercury Limit Test, its content should not be more than 1.0 ppm.

(6) Bromide : Weigh 1 g of Potassium Chloride, and dissolve in water to make 100 mL. Take 5 mL of this solution, add 3 drops of hydrochloric acid (1→4) and 1 mL of chloroform, and add 3 drops of chloramine T solution (1.25 g of chloramines T in 100 mL of water, prepared before use) while shaking. The color of the chloroform layer does not change to yellow to yellow ~ red.

(7) Iodide : Weigh 0.5 g of Potassium Chloride, dissolve in 10 mL of water, add 3 drops of ferric chloride solution (1→10) and 1 mL of chloroform, shake, allow to stand for 30 minutes, and shake again. The color of the chloroform layer does not change to red-purple to purple.

(8) Sodium : When Flame Coloration Test is conducted with Potassium Chloride solution (1→20), it should not show yellow or bright flame.

(9) Calcium or Magnesium : Weigh 0.2 g of Potassium Chloride, dissolve in 20 mL of water, add 2 mL of ammonia solution, 2 mL of ammonium oxalate solution (1→30), and 2 mL of disodium phosphate solution (1→8), and allow to stand for 5 minutes. The solution should not become turbid.

Loss on Drying When Potassium Chloride is dried for 4 hours at 105°C, the weight loss should be more than 1.0%.

Assay Transfer 0.25 g of Potassium Chloride, previously dried and accurately weighed, into a flask with a ground-glass stopper, dissolve in 50 mL of water, add 50 mL of 0.1 N silver nitrate and 5 mL of nitric acid and 5 mL of nitrobenzene while shaking, and shake vigorously. Add 2 mL of ferric ammonium sulfate solution, and titrate the excess silver nitrate with 0.1 N ammonium thiocyanate.

1 mL of 0.1 N silver nitrate = 7.456 mg of KCl

Potassium Citrate



Chemical Formula: $\text{C}_6\text{H}_5\text{K}_3\text{O}_7\cdot\text{H}_2\text{O}$

Molecular Weight: 324.41

INS No.: 332(ii)

Synonyms: Tripotassium citrate; Tribasic potassium citrate

CAS No.: 6100-05-6

Compositional Specifications of Potassium Citrate

Content Potassium Citrate, when calculated on the dried basis, should contain not less than 99.0% of potassium citrate ($\text{C}_6\text{H}_5\text{K}_3\text{O}_7$).

Description Potassium Citrate occurs as colorless crystals or as a white crystalline powder, and is odorless.

Identification Potassium Citrate solution (1→20) responds to the test for Citrate and Potassium Salt in Identification.

Purity (1) Arsenic : It should be no more than 1.3 ppm tested by Arsenic Limit Test.

(2) Lead : When 5.0 g of Potassium Citrate is tested by Atomic Absorption Spectrophotometry or Inductively Coupled Plasma Emission Spectroscopy, its content should not be more than 1.0 ppm.

(3) Mercury : When Potassium Citrate is tested by Mercury Limit Test, its content should not be more than 1.0 ppm.

(4) Alkalinity : Potassium Citrate solution(1→20) is alkaline as tested with a litmus paper.

Loss on Drying When Potassium Citrate is dried for 4 hours at 180°C, the weight loss should be within a range of 3 ~ 6%.

Assay 250 mg of Potassium Citrate, precisely dried and accurately weighed, is dissolved in 40 mL of glacial acetic acid by heating. After cooling to room temperature, the solution is titrated with 0.1 N perchloric acid (indicator : 2 drops of crystal violet · glacial acetic acid solution). Separately, a blank test is carried out by the same procedure.

$$1 \text{ mL of } 0.1 \text{ N perchloric acid} = 10.213 \text{ mg } \text{C}_6\text{H}_5\text{K}_3\text{O}_7$$

Potassium Copper Chlorophyllin

Synonyms: Potassium chlorophyllin

INS No.: 141(ii)

[Content Specifications of Potassium Copper Chlorophyllin

Content Potassium Copper Chlorophyllin, when calculated on the dried basis at 100°C for 1 hour, should contain not less than 95.0% of total copper chlorophyllin.

Description Potassium Copper Chlorophyllin is dark green ~ blue, black powder or dark green liquid.

Identification (1) The residue after thermogravimetric analysis using 1 g of Potassium Copper Chlorophyllin is dissolved in 10 mL of dilute hydrochloric acid by heating in a water bath. If the solution is not clear, it is filtered. 10 mL of water is added (Test Solution). The following tests are carried out with the Test Solution.

(A) When 5 mL of the Test Solution turns alkaline by adding ammonia solution, it shows blue color.

(B) When 0.5 mL of diethyldithio sodium carbamate solution (1→1,000) is added to 5 mL of the Test Solution, it forms brown precipitates.

(2) Test Solution in (1) responds to test of potassium salts in Identification.

(3) Approximately 0.1 g of Potassium Copper Chlorophyllin add water to make 1,000 mL. Take 10 mL of this solution is further diluted to 100 mL with phosphate buffer solution (pH 7.5). Using this solution, absorption is measured and the maximum absorption (converted to anhydrous form) near 405 nm should not be less than $E_{1cm}^{1\%} = 540$.

Purity (1) Arsenic : It should be no more than 4.0 ppm tested by Arsenic Limit Test.

(2) Lead : When 5.0 g of Potassium Copper Chlorophyllin is tested by Atomic Absorption Spectrophotometry or Inductively Coupled Plasma Emission Spectroscopy, its content should not be more than 5.0 ppm.

(3) Cadmium : When 5.0 g of Potassium Copper Chlorophyllin is tested by Atomic Absorption Spectrophotometry or Inductively Coupled Plasma Emission Spectroscopy, its content should not be more than 1.0 ppm.

(4) Mercury : When Potassium Copper Chlorophyllin is tested by Mercury Limit Test, its content should not be more than 1.0 ppm.

(5) Inorganic Copper Salts : Proceed as directed under Purity (8) for 「Sodium Copper Chlorophyllin」. However, Test Solution is prepared with 1 g of Potassium Copper Chlorophyllin in 60 mL water (Not more than 200 µg/g as Cu).

(6) Total Copper : 0.1 g of Potassium Copper Chlorophyllin, precisely weighed, is transferred into a porcelain crucible. It is then heat-treated at a temperature below 500°C until carbon is removed. 1 ~ 2 drops of sulfuric acid is added to the residue, which is then reduced to ash. 5 mL of 10%(w/w)

hydrochloric acid is added to the residue three times to the ash. It is then heated to dissolve the ash and filtered through a filter paper. The filtrate is cooled and the total volume is brought up to 100 mL with water (Test Solution). Test Solution is analyzed with atomic absorption spectrophotometer to obtain total copper. The content should not be more than 8% of the total Copper Chlorophyllin.

(7) Alkaline Pigments : 5 mL of 0.5% aqueous solution of Potassium Copper Chlorophyllin is transferred into a test tube. Add 1 mL of 1 N hydrochloric acid and 5 mL of ether, and well mixed, and set-aside. The ether layer should not be darker than pale green.

(8) Residual Solvent : When Potassium Copper Chlorophyllin is tested by Purity (5) for 「Paprika Extract Pigments」,

Acetone	}	Not more than 50 ppm(individual or total if combined)
Methyl alcohol		
Ethyl alcohol		
Isopropyl alcohol		
Hexane		
Methylene Chloride	—	Not more than 10 ppm

Assay Dissolve 1 g of Potassium Copper Chlorophyllin, previously dried at 100°C for 1 hour and accurately weighed in 20 mL of phosphate buffer solution (pH 7.5), which is diluted to 1,000 mL with water. 10 mL of this solution is further diluted to 100 mL with phosphate buffer solution (pH 7.5) (Test Solution). The content is calculated from the following equation using absorption A of the Test Solution at the maximum absorption near 403 ~ 406 nm wavelength with 1 cm path length.

$$\text{Content(\%)} = \frac{A \times 10^4}{565 \times \text{weight of the sample(g)}}$$

565 : Specific Optical Density of Potassium Copper Chlorophyllin ($E_{1\text{cm}}^{1\%}$)

Potassium Ferrocyanide

Chemical Formula: $K_4Fe(CN)_6 \cdot 3 H_2O$

Molecular Weight: 422.39

INS No.: 536

Synonyms: Hexacyanoferrate of potassium; Yellow prussiate of potash

CAS No.: 3943-58-3

Compositional Specifications of Potassium Ferrocyanide

Content When Potassium ferrocyanide is quantified, it should contain not less than 99.0% of potassium ferrocyanide ($K_4Fe(CN)_6 \cdot 3H_2O$)

Description Potassium ferrocyanide is a white crystal or crystalline powder.

Identification (1) When 1 mL of ferric chloride is added to 10 mL of Potassium ferrocyanide (1→100), a dark blue precipitate is formed.

(2) Potassium ferrocyanide responds to test of potassium salt in the identification method.

Purity (1) Cyanide : 10 mg of copper sulfate is dissolved in 8 mL of water and 2 mL of ammonium solution. A filtering paper is dipped into this solution, to which hydrogen sulfide is then added. When 1 drop of the aqueous solution of Potassium ferrocyanide (1→100) is dropped on the filtering paper that turned brown, white rings should not appear.

(2) Ferrocyanide : 10 mg of Potassium ferrocyanide is dissolved in 10 mL of water and added 1 drop of this solution. When a few drops of 2 N acetic acid and that is saturated with benzidine and 1 drop of 1% lead nitrate are added, blue precipitates or color should not formed.

(3) Lead : Accurately weigh 5.0 g of Potassium ferrocyanide into a 150 mL beaker, add 30 mL of water. Add Hydrochloric acid in small portion to the solution until the solid is dissolved throughly and add 1 mL of hydrochloric acid. Heat this solution for approximately 5 minutes and cool down. Add water to bring the total volume to 100 mL. Add Sodium Hydroxide Solution(1→4) or Hydrochloric acid(1→4) so that pH becomes 2 ~ 4. Transfer this solution into 250 mL separatory funnel, where water is added to make 200 mL. Then add 2 mL of 2% APDC solution and shake to mix. Extract the solution 2 times with 20 mL each of chloroform, which is evaporated to dryness in a water bath. Add 3 mL of Nitric Acid to the residue and heat it until nearly evaporated. To this solution, add 0.5 mL of Nitric Acid and 10 mL of water, concentrate it until the final solution becomes 3~5 mL, and add water to make 10 mL, test solution. When the test solution is tested by Atomic Absorption Spectrophotometry or Inductively Coupled Plasma Emission Spectroscopy, its content should not be more than 5.0 ppm.

2% APDC Solution : 2.0 g of Ammonium Pyrolidine Dithiocarbamate is dissolved in water to make 100 mL. Filter it when using.

(4) Chloride : When 0.11 g of Potassium ferrocyanide is tested by Chloride Limit Test, the detected amount should not be more than the amount that corresponds to 0.6 mL of 0.01 N hydrochloric

acid.(not more than 0.2%)

- (2) (5) Sulfate : When 0.2 g of Potassium ferrocyanide is tested by Sulfate Limit Test, the detected amount should not be more than the amount that corresponds to 0.4 mL of 0.01 N hydrochloric acid. (not more than 0.1%)

Water Content Water content of Potassium ferrocyanide is determined by water determination (Karl-Fisher Titration) and should not be more than 1.0%.

Assay About 1.0 mg of Potassium ferrocyanide is weighed accurately, dissolved in 200 mL of water, and 10 mL of sulfuric acid is added. Then the solution is titrated with 0.02 N potassium permanganate until the red color lasts for 30 secs.

0.02 N potassium permanganate 1 mL = 42.24 mg of $K_4Fe(CN)_6 \cdot 3H_2O$

Potassium Gluconate

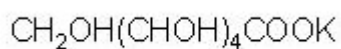

Chemical Formula: $\text{C}_6\text{H}_{11}\text{KO}_7$

$\text{C}_6\text{H}_{11}\text{KO}_7 \cdot \text{H}_2\text{O}$

Molecular Weight: 234.25(anhydrous)

252.26(1hydrate)

INS No.: 577

Synonyms: Potassium salt of D-gluconic acid;

Potassium D-gluconate

CAS No.:

299-27-4(anhydrous)

35398-15-3(1hydrate)

Compositional Specifications of Potassium Gluconate

Content When Potassium Gluconate, when calculated on the dried basis(anhydrous), should contain within a range of 97.0~103.0% of potassium gluconate ($\text{C}_6\text{H}_{11}\text{KO}_7$).

Description Potassium Gluconate is scentless white ~ yellowish white granule or crystalline powder.

Identification (1) Potassium Gluconate solution (1→20) responds to test of potassium salts in Identification.

(2) 5 mL of Potassium Gluconate solution (1→10) is tested by (3) Identification for [glucono- δ -lactone].

Purity (1) pH : pH of Potassium Gluconate solution (1→10) is measured by glass electrode method and should be within a range of 7.3~8.5.

(2) Arsenic : It should be no more than 4.0 ppm tested by Arsenic Limit Test.

(3) Lead : When 5.0 g of Potassium Gluconate is tested by Atomic Absorption Spectrophotometry or Inductively Coupled Plasma Emission Spectroscopy, its content should not be more than 2.0 ppm.

(4) Reducing Matter : Approximately 1 g of Potassium Gluconate is weighed into a 250 mL Erlenmeyer flask. 10 mL of water is added to dissolve the solid and 25 mL of alkaline copper citrate solution. A small beaker is placed on top of the flask, which is heated for precisely 5 minutes. It is then rapidly cooled to room temperature. To this solution, 25 mL of diluted acetic acid (1→10), 10 mL of 0.1 N iodine solution, 10 mL of dilute hydrochloric acid, and 3 mL of starch solution are added. The resulting solution is titrated with 0.1 N sodium thiosulfate solution until the blue color disappears. The content of reduced materials should not be more than 0.5%.

$$\text{Reducing Matter Content (as glucose)(\%)} = \frac{(V_1N_1 - V_2N_2) \times 27}{\text{Weight of sample(mg)}} \times 100$$

V_1 : Consumed amount of 0.1 N iodine solution (mL)

N_1 : Normality of 0.1 N iodine solution

V_2 : Consumed amount of 0.1 N sodium thiosulfate solution (mL)

N_2 : Normality of 0.1 N sodium thiosulfate solution

27 : Experimental corresponding amount for D-glucose

Loss on Drying When Potassium Gluconate is dried for 5 hours at 105°C, the loss should not be more than 3.0% and 6.0 ~ 7.5% for a dehydrated form and hydrate, respectively.

Assay Proceed as directed under Assay of 「Sodium Gluconate.

1 mL of 0.1 N perchloric acid solution = 23.24 mg $C_6H_{11}KO_7$

Potassium Glycerophosphate

Chemical Formula: $C_3H_7K_2O_6P \cdot 3H_2O$

Molecular Weight: 302.30

CAS No.: 1319-70-6

Compositional Specifications of Potassium Glycerophosphate

Content Potassium Glycerophosphate (trihydrate) should not contain less than 80.0% of potassium glycerophosphate ($C_3H_7K_2O_6P$) and Potassium Glycerophosphate solution (50 ~ 75% concentration) should contain within a range of 95.0 ~ 105.0% of the specified content of potassium glycerophosphate ($C_3H_7K_2O_6P$).

Description Potassium Glycerophosphate (trihydrate) is gluey liquid with pale yellow color. Solution of 50 ~ 75% concentration is gluey liquid with colorless ~ pale yellow color.

Identification (1) Potassium Glycerophosphate solution (1→10) responds to the test for Potassium Salts in Identification.

(2) When 0.1 g of Potassium Glycerophosphate is heated with 0.5 g of potassium hydrogen sulfate, pungent vapor of aclorein is generated.

Purity (1) Lead : When 5.0 g of Potassium Glycerophosphate is tested by Atomic Absorption Spectrophotometry or Inductively Coupled Plasma Emission Spectroscopy, its content should not be more than 4.0 ppm.

Assay Potassium Glycerophosphate is precisely weighed so that the amount corresponds to 4 g of potassium glycerophosphate ($C_3H_7K_2O_6P$). It is then dissolved in 30 mL of water and titrated with 0.5 N hydrochloric acid (indicator : methyl orange indicator solution).

1 mL of 0.5 N hydrochloric acid solution = 124.13 mg $C_3H_7K_2O_6P$

Potassium Hydroxide

Chemical Formula: KOH

Molecular Weight: 56.11

Synonyms: Caustic potash

INS No.: 525

CAS No.: 1310-58-3

Compositional Specifications of Potassium Hydroxide

Content Potassium Hydroxide should contain not less than 85.0% of Potassium Hydroxide (KOH).

Description Potassium Hydroxide occurs as white having various shapes including small spheres, pellets, rods, lumps or powder.

Identification (1) Potassium Hydroxide solution in water (1→50) is strongly alkaline.

(2) Potassium Hydroxide solution in water (1→25) responds to Potassium Salt in Identification.

Purity (1) Clarity and Color of Solution : When 1 g of Potassium Hydroxide is dissolved in 20 mL of water, the solution should be colorless and clear.

(2) Potassium Carbonate : The content of potassium Carbonate (K_2CO_3) obtained in Assay is not more than 3.5%.

(3) Arsenic : It should be no more than 4.0 ppm tested by Arsenic Limit Test.

(4) Lead : Potassium Hydroxide is tested by purity (2) for 「Sodium Metaphosphate」(not more than 2.0 ppm).

(5) Mercury : Dissolve 2 g of Potassium Hydroxide in 10 mL of water, add 1 mL of the potassium permanganate solution (3→50) and about 30 mL of water, and shake well. Neutralize by gradually adding purified hydrochloric acid, add 5 mL of diluted sulfuric acid (1→2), and cool. Use this solution as the test solution. Add hydroxylamine hydrochloride solution (1→5) until the purple color of the permanganate in the test solution disappears and the precipitate of the manganese dioxide dissolves, add water to make 100 mL, and transfer into the gas washing bottle of an atomic absorption spectrophotometer. Add 10 mL of stannous chloride solution, immediately connect with the atomic absorption spectrophotometer, and start the diaphragm pump to circulate the air. When the recorder reading increases rapidly and then it indicates a constant value, measure the absorbance. The absorbance of test solution should not be higher than that of the following solution: Take 2.0 mL of Mercury Standard Solution, add 1 mL of potassium permanganate solution (3→50), 30 mL of water, and the same amount of purified hydrochloric acid as that used for preparing the test solution, and process in the same manner as the test solution not more than 0.1 ppm.

Assay Accurately weigh about 50 g of Potassium Hydroxide, and dissolve in freshly boiled and cooled water to make 1,000 mL. Use this solution as the test solution. Take 25 mL of the test solution, add 10 mL of freshly boiled and cooled water, and titrate with 1 N hydrochloric acid (indicator : 1 mL of

bromophenol blue solution). After neutralizing, add about 1 mL of 1 N hydrochloric acid, and boil for about 5 minutes. After cooling, titrate the excess acid with 0.1 N sodium hydroxide, and determine the volume (A mL) of consumed 1 N hydrochloric acid. Separately, measure exactly 25 mL of the test solution, transfer into a flask with a ground stopper, and add 25 mL of freshly boiled and cooled water. To the solution, add 10 mL of the barium chloride solution, stopper, shake gently, and titrate with 1 N hydrochloric acid (indicator : 1 mL of phenolphthalein solution). Let (B mL) be the consumed volume.

$$\text{Content of potassium hydroxide(KOH)(\%)} = \frac{0.0561(\text{g}) \times B \times 40}{\text{weight of the sample(g)}} \times 100$$

$$\text{Content of potassium carbonate(K}_2\text{CO}_3) = \frac{0.0691(\text{g}) \times (A-B) \times 40}{\text{weight of the sample(g)}} \times 100$$

Potassium Iodate

Chemical Formula: KIO_3

INS No.: 917

Molecular Weight: 214.00

CAS No.: 7758-05-6

Compositional Specifications of Potassium Iodate

Content Potassium Iodate, when calculated on the dried basis, should contain within a range of 99.0~101% of Potassium Iodate(KIO_3).

Description Potassium Iodate occurs as white crystalline powder and is odorless.

Identification

- (1) Potassium Iodate is soluble in water but insoluble in ethanol.
- (2) Potassium Iodate responds to the test for Potassium Salt reactions.
- (3) When Potassium Iodate solution (1→20) is added 1 drop of starch solution and a few drops of 20% hypophosphorous acid solution, the color of solution temporarily turns to blue.

Purity

(1) Free acid and Free Alkali : 5 g of Potassium Iodate is weighed and dissolved in 40 mL of water (previously boiled and cooled) and is added to 3 drops of phenolphthalein solution. Then the following test is performed.

- ① If the solution is colorless, add 1.2 mL of 0.01 N sodium hydroxide. A red color develops.
- ② If the solution is red, add 0.4 mL of 0.01 N hydrochloric acid. The color disappears.

(2) Lead : Potassium Iodate is tested by purity (2) for 「Sodium Metaphosphate」(not more than 2.0 ppm).

Loss on Drying When Potassium Iodate is dried at 150°C for 3 hours, the weight loss should not be more than 0.5%.

Assay Dissolve 0.1 g of Potassium Iodate, previously dried at 105°C for 3 hours and accurately weighed, in 50 mL of water on the Erlenmeyer flask. 3 mL of hydrochloric acid and 3g of potassium iodide are added and the stopper is placed on the flask, which is set-aside for 5 minutes. Separated Iodine formed by adding 100 mL of cold water is titrated with 0.1N sodium thiosulfate solution (indicator: starch solution). Separately, a blank test is done following the same procedure.

$$1 \text{ mL of } 0.1 \text{ N sodium thiosulfate solution} = 3.567 \text{ mg } \text{KIO}_3$$

Potassium Lactate

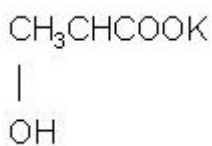

Chemical Formula: $\text{C}_3\text{H}_5\text{KO}_3$

Molecular Weight: 128.17

INS No.: 326

Synonyms: Potassium lactate (solution); Potassium
2-hydroxypropanoate

CAS No.: 996-31-6

Compositional Specifications of Potassium Lactate

Content Potassium Lactate contains 60.0% of potassium lactate ($\text{C}_3\text{H}_5\text{KO}_3$) and 95.0 ~ 110.0% of its indicated content.

Description Potassium Lactate is colorless clear syrup-like liquid. It may or may not have slight characteristic scent.

Identification (1) Potassium Lactate responds to test of potassium salt in Identification.

(2) Ash of Potassium Lactate is alkaline. When acid is added, it foams.

(3) When 5 mL of catechol solution in sulfuric acid (1→100) is added to 2 mL of Potassium Lactate, the contact area turns deep red.

Purity (1) Lead : When 5.0 g of Potassium Lactate is tested by Atomic Absorption Spectrophotometry or Inductively Coupled Plasma Emission Spectroscopy, its content should not be more than 2.0 ppm.

(2) Mercury : When Potassium Lactate is tested by Mercury Limit Test, its content should not be more than 1.0 ppm.

(3) Arsenic : It should be no more than 4.0 ppm tested by Arsenic Limit Test.

(4) Acid value : An amount, that corresponds to 0.6 g calcium lactate, of Potassium Lactate is dissolved in 20 mL of water. 3 drops of phenolphthalein solution is added to this solution, which is titrated with 0.1 N sodium hydroxide solution. The consumed amount should not be more than 0.2 mL.

(5) Reducing Matter : When Potassium Lactate is added to Fehling solution, the solution should not be under go any changes.

Assay An amount, that corresponds to 0.6 g calcium lactate, of Potassium Lactate is precisely weighed into a flask. 60 mL of anhydrous acetic acid and glacial acetic acid mixture (1:4) is added to the flask and mixed. After settling for 20 minutes, it is titrated with 0.1 N perchloric acid solution (indicator : 1 mL of crystal violet-glacial acetic acid). At the end point, the color of the solution changes from blue to green. Separately, a blank test is carried out following the same procedure

1 mL of 0.1 N perchloric acid solution = 12.82 mg $C_3H_5KO_3$

Potassium Metabisulfite

Potassium pyrosulfite

Chemical Formula: $K_2S_2O_5$

Molecular Weight: 222.33

INS No.: 224

Synonyms: Potassium pyrosulfite

CAS No.: 16731-55-8

Compositional Specifications of Potassium Metabisulfite

Content Potassium metabisulfite should contain not less than 93.0% of potassium metabisulfite ($K_2S_2O_5$).

Description Potassium metabisulfite occurs as white crystals or crystalline powder having an odor of sulfur dioxide.

Identification (1) To Potassium metabisulfite, add dilute hydrochloric acid, then sulfur dioxide is generated.

(2) To 5 mL of a solution of Potassium metabisulfite (1→10), add 1 mL of dilute acetic acid. When iodine · potassium iodine solution is drop-wise added to this solution, the color of the solution disappears.

(3) Potassium metabisulfite responds to the test for Potassium Salt in Identification.

Purity (1) Clarity and Color of Solution : When 1 g of Potassium metabisulfite is dissolved in 10 mL of water, the solution should be almost clear.

(2) Arsenic : It should be no more than 4.0 ppm tested by Arsenic Limit Test.

(3) Lead : Potassium metabisulfite is tested by purity (2) for 「Sodium Metaphosphate」(not more than 2.0 ppm).

(4) Iron : When the test solution of (3) in Purity is tested by Atomic Absorption Spectrophotometry or Inductively Coupled Plasma Emission Spectroscopy, its content should not be more than 10 ppm.

(5) Selenium : Accurately weigh 2.0 g of Potassium metabisulfite transfer into a 50 mL beaker, add 10 mL of water and 5 mL of hydrochloric acid, and boil to remove sulfur dioxide, Test Solution. Accurately weigh 1.0 g of Potassium metabisulfite, transfer into another beaker, and add 0.5 mL of selenium standard solution. Then prepare a reference solution by the same manner as for test solution. Add 2 g of hydrazin sulfate transfer into each beaker, heat and dissolve. Transfer the resulting solution into a Nestler cylinder with adding water to make 50 mL. When comparing both colors, the red color of test solution should not be darker than that of reference solution (Not more than 5 ppm).

(6) Mercury : When Potassium metabisulfite is tested by Mercury Limit Test, its content should not be more than 1.0 ppm.

(7) Thiosulphate : When 10% solution of potassium metabisulfite is acidified with sulfuric Acid or hydrochloric acid, it should be transparent (not more than 0.1%).

Assay Accurately weigh about 0.2 g of Potassium metabisulfite transfer into a flask with a ground glass

stopper, add 50 mL of 0.1 N iodine solution. It is set-aside for 5 minutes, where 2 mL of diluted hydrochloric acid (2→3) is added. The excess iodine is titrated with 0.1N sodium thiosulfate solution (indicator : starch solution).

1 mL of 0.1 N iodine solution = 5.558 mg $K_2S_2O_5$

Potassium Metaphosphate

INS No.: 452(ii)

Synonyms: Potassium polyphosphates; Potassium
polymetaphosphate

CAS No.: 7790-53-6

Compositional Specifications of Potassium Metaphosphate

Content Potassium Metaphosphate, when calculated on the dried basis, should contain within a range of 53.0 ~ 80.0% of phosphorus pentoxide ($P_2O_5 = 141.95$).

Description Potassium Metaphosphate occurs as colorless to white glassy flakes or lumps, or as white fibrous crystals or powder.

Identification (1) When Potassium Metaphosphate is tested by Flame Coloration Test, it shows light violet color.

(2) To 0.1 g of Potassium Metaphosphate, add 0.4 g of sodium acetate, dissolve in 10 mL of water, make slightly acidic with diluted acetic acid or sodium hydroxide solution, and add 5 mL of egg white solution. A white precipitate is formed.

Purity (1) Clarity and Color of Solution : To 1 g of Potassium Metaphosphate, add 50 mL of water, and heat in a water bath. Sodium acetate solution is prepared by dissolving 4 g of sodium acetate in 50 mL of water and heating in a water bath. The resulting solution should be colorless and slightly turbid or better.

(2) Chloride : When 0.1 g of Potassium Metaphosphate is tested by Chloride Limit Test, its content should not be more than the amount that corresponds to 0.3 mL of 0.01 N sulfuric acid.

(3) Sulfate : 0.1 g of Potassium Metaphosphate is dissolved in 30 mL of water and 2 mL of dilute hydrochloric acid by boiling for 1 minute. After cooling, the solution is tested by Sulfate Limit Test and its content should not be more than the amount that corresponds to 0.2 mL of 0.01 N sulfuric acid.

(4) Orthophosphate : To 1 g of Potassium Metaphosphate, add 2 ~ 3 drops of silver nitrate solution. No brilliant yellow color develops.

(5) Arsenic : It should be no more than 4.0 ppm tested by Arsenic Limit Test.

(6) Lead : Potassium Metaphosphate is tested by purity (2) for 「Sodium Metaphosphate」(not more than 4.0 ppm).

(7) Cadmium : Potassium Metaphosphate is tested by purity (3) for 「Sodium Metaphosphate」(not more than 1.0 ppm).

(8) Mercury : When Potassium Metaphosphate is tested by Mercury Limit Test, its content should not be more than 1.0 ppm.

(9) Fluoride : 1 g of Potassium Metaphosphate is precisely weighed and is tested by purity (8) for

「Calcium Citrate」(not more than 10 ppm).

Loss on Drying When Potassium Metaphosphate is dried for 4 hours at 110°C, the weight loss should not be more than 5%.

Loss on Ignition When Potassium Metaphosphate is dried for 4 hours at 105°C and heated for 30 minutes at 550°C, the weight loss should not be more than 2.0%.

Assay Proceed as directed under Assay in 「Sodium Metaphosphate」.

Potassium Nitrate

Chemical Formula: KNO_3

Molecular Weight: 101.11

Synonyms: Nitre; Saltpetre

INS No.: 252

CAS No.: 7757-79-1

Compositional Specifications of Potassium Nitrate

Content Potassium Nitrate, when calculated on the dried basis, should contain not less than 99.0% of potassium nitrate (KNO_3).

Description Potassium Nitrate occurs as colorless and pillared crystals or as a white crystalline powder. It is odorless and has a salty and refreshing taste.

Identification Potassium Nitrate responds to the tests for Potassium Salt and Nitrate in Identification.

Purity (1) Clarity and Color of Solution : 1 g of Potassium Nitrate is dissolved 10 mL of water. It is colorless and clear.

(2) Chloride : When 0.5 g of Potassium Nitrate is tested by Chloride Limit Test, its content should not be more than the amount that corresponds to 0.3 mL of 0.01 N sulfuric acid.

(3) Arsenic : It should be no more than 4.0 ppm tested by Arsenic Limit Test.

(4) Lead : Accurately weigh 5.0 g of Potassium Nitrate into a 150 mL beaker, add 30 mL of water. Add Hydrochloric acid in small portion to the solution until the solid is dissolved thoroughly and add 1 mL of hydrochloric acid. Heat this solution for approximately 5 minutes and cool down. Add water to bring the total volume to 100 mL. Add Sodium Hydroxide Solution(1→4) or Hydrochloric acid(1→4) so that pH becomes 2 ~ 4. Transfer this solution into 250 mL separatory funnel, where water is added to make 200 mL. Then add 2 mL of 2% APDC solution and shake to mix. Extract the solution 2 times with 20 mL each of chloroform, which is evaporated to dryness in a water bath. Add 3 mL of Nitric Acid to the residue and heat it until nearly evaporated. To this solution, add 0.5 mL of Nitric Acid and 10 mL of water, concentrate it until the final solution becomes 3~5 mL, and add water to make 10 mL, test solution. When the test solution is tested by Atomic Absorption Spectrophotometry or Inductively Coupled Plasma Emission Spectroscopy, its content should not be more than 2.0 ppm.

2% APDC Solution : 2.0 g of Ammonium Pyrolidine Dithiocarbamate is dissolved in water to make 100 mL. Filter it when using.

(5) Mercury : When Potassium Nitrate is tested by Mercury Limit Test, its content should not be more than 1.0 ppm.

(6) Nitrite : 1 g of Potassium Nitrate, precisely weighed, dissolve in water to make 100 mL. Take 20 mL of this solution, transfer into a 100 mL flask and add water to make 80 mL. Add 10 mL of sulfanilamide solution and mix. After 3 minutes, 1 mL of coupling solution is added, water is added to make 100

mL, and mixed well. Allow the solution to stand for 15 minutes and measure absorbance at a wavelength of 540 nm. Calculate the content of Nitrite by calibration curve and following formula and it should not be more than 20 ppm.

$$\text{Nitrite(ppm)} = \frac{A \times 5}{W}$$

A : content of nitrite calculated from calibration curve (μg)

W : weight of sample(g)

Calibration Curve Preparation : 0, 5, 10, 20, and 50 mL (0, 2.5, 5, 10, and 25 μg as nitrite) of standard solution is weighed into a 100 mL flask respectively, water is added to make 80 mL for each. 10 mL of sulfanilamide solution is added and mixed. After 3 minutes, 1 mL of coupling solution is added for each, water is added to make 100 mL, and mixed well. Allow the solution to stand for 15 minutes, measure absorbance at a wavelength of 540 nm, and prepare calibration.

Sulfanilamide solution : 2 g of Sulfanilamide is dissolved in diluted hydrochloric acid to make 1000 mL.

Coupling solution : 0.2 g of N-1-naphthylethylenediamine dihydrochloride is dissolved in water to make 100 mL.

Standard solution : 0.75 g of sodium nitrite 0.75g is precisely weighed and dissolved in water to make 1000 mL. 10 mL of this solution is measured to bring 100 mL, and again 10 mL of this solution is measured to bring 1000 mL.

Loss on Drying When Potassium Nitrate is dried for 4 hours at 105°C, the loss should not be more than 1%.

Assay Accurately weigh about 0.4 g of Potassium Nitrate, previously dried, transfer into a 500 mL round-bottom flask and dissolve in about 300 mL of water. Add 3 g of powdered Devarda's alloy and 15 mL of sodium hydroxide solution (2→5). Connect the flask immediately with the distilling apparatus, which is previously equipped with a splash preventing device and a condenser and is connected with the receiver containing 50 mL of 0.1 N sulfuric acid, exactly measured. Allow to stand for 2 hours, and distill until about 250 mL of the distillate is produced. Titrate the excess acid with 0.1 N sodium hydroxide (indicator : 3 drops of methyl red-methylene blue mixture solution). Perform a blank test in the same manner.

1 mL of 0.1 N sulfuric acid = 10.11 mg of KNO_3

Potassium Phosphate, Dibasic

Chemical Formula: K_2HPO_4

Molecular Weight: 174.18

INS No.: 340(ii)

Synonyms: Dipotassium hydrogen phosphate;
Dipotassium acid phosphate

CAS No.: 7758-11-4

Compositional Specifications of Potassium Phosphate, Dibasic

Content Potassium Phosphate, Dibasic, when calculated on the dried basis, should contain not less than 98.0% of dibasic potassium phosphate (K_2HPO_4).

Description Potassium Phosphate, Dibasic is white powder, crystal, or lump.

Identification (1) Potassium Phosphate, Dibasic, solution (1→20) adding 1 drop of phenolphthalein solution turns red.

(2) Potassium Phosphate, Dibasic solution (1→20) responds to test of potassium salts and Phosphate in Identification.

Purity (1) Water Insoluble Substances : 10 g of Potassium Phosphate, Dibasic is tested for water insoluble substances by Purity (1) for 「Sodium Acid Pyrophosphate」. The content of water insoluble substances should not be more than 0.2%.

(2) pH : An aqueous solution (1→100) of Potassium Phosphate, Dibasic should have pH of 8.7~9.3.

(3) Arsenic : It should be no more than 4.0 ppm tested by Arsenic Limit Test.

(4) Lead :Potassium Phosphate, Dibasic is precisely weighed and is tested by purity (2) for 「Sodium Metaphosphate」, its content should not be more than 4.0 ppm.

(5) Cadmium : Potassium Phosphate, Dibasic is precisely weighed and is tested by purity (3) for 「Sodium Metaphosphate」, its content should not be more than 1.0 ppm.

(6) Mercury : When Potassium Phosphate, Dibasic is tested by Mercury Limit Test, its content should not be more than 1.0 ppm.

(7) Fluoride : 1 g of Potassium Phosphate, Dibasic is precisely weighed and is tested by purity (8) for 「Calcium Citrate」, its content should not be more than 10 ppm.

Loss on Drying When Potassium Phosphate, Dibasic is dried for 4 hours at 105°C, the loss should not be more than 2.0%.

Assay Dissolve 3 g of Potassium Phosphate, Dibasic, previously dried and accurately weighed, in 50 mL of water. The solution is kept at 15°C and titrated with 1 N hydrochloric acid (indicator : 3 ~ 4 drops of Methyl Orange.Xylene Cyanol FF solution).

1 mL of 1 N hydrochloric acid = 174.2 mg K_2HPO_4

Potassium Phosphate, Monobasic

Chemical Formula: KH_2PO_4

Molecular Weight: 136.09

INS No.: 340(i)

Synonyms: Potassium dihydrogen phosphate;

Monopotassium monophosphate;

CAS No.: 7778-77-0

Potassium acid phosphate

Compositional Specifications of Potassium Phosphate, Monobasic

Content Potassium Phosphate, Monobasic, when calculated on the dried basis, should contain not less than 98.0% of monobasic potassium phosphate (KH_2PO_4).

Description Potassium Phosphate, Monobasic is colorless crystallite or white granule or crystalline powder.

Identification (1) Potassium Phosphate, Monobasic solution (1→20) is acidic.

(2) Potassium Phosphate, Monobasic solution (1→20) responds to test of of Potassium Salt and Phosphate in Identification.

Purity (1) Water Insoluble Substances : 10 g of Potassium Phosphate, Monobasic is tested by Purity (1) for 「Sodium Acid Pyrophosphate」. The content of water insoluble substances should not be more than 0.2%.

(2) pH : pH of Potassium Phosphate, Monobasic solution (1→100) should be within a range of 4.2~4.7.

(3) Arsenic : It should be no more than 4.0 ppm tested by Arsenic Limit Test.

(4) Lead : Potassium Phosphate, Monobasic is precisely weighed and is tested by purity (2) for 「Sodium Metaphosphate」, its content should not be more than 4.0 ppm.

(5) Cadmium : Potassium Phosphate, Monobasic is precisely weighed and is tested by purity (3) for 「Sodium Metaphosphate」, its content should not be more than 1.0 ppm.

(6) Mercury : When Potassium Phosphate, Monobasic is tested by Mercury Limit Test, its content should not be more than 1.0 ppm.

(7) Fluoride : 1 g of Potassium Phosphate, Monobasic is precisely weighed and is tested by purity (8) for 「Calcium Citrate」, its content should not be more than 10 ppm.

Loss on Drying When Potassium Phosphate, Monobasic is dried for 4 hours at 105°C, the loss should not be more than 2.0%.

Assay Dissolve 3 g of Potassium Phosphate, Monobasic, previously dried and accurately weighed, in 30 mL of water. 5 g of sodium chloride is added, which is dissolved by shaking. While the solution is kept at 15°C, it is titrated with 1 N sodium hydroxide solution (Indicator : 3 ~ 4 drops of thymol blue solution)

1 mL of 1 N sodium hydroxide solution = 136.1 mg KH_2PO_4

Potassium Phosphate, Tribasic

Chemical Formula: $K_3PO_4 \cdot nH_2O$ (n=0 or 3)

Molecular Weight: 3hydrates 266.31
anhydrous 212.27

INS No.: 340(iii)

Synonyms: Tripotassium phosphate

CAS No.: 7778-53-2

Compositional Specifications of Potassium Phosphate, Tribasic

Content When Tribasic Potassium Phosphate is heat-treated and analyzed quantitatively analyzed, should contain not less than 97.0% Tribasic potassium phosphate ($K_3PO_4 = 212.28$).

Description Tribasic Potassium Phosphate is colorless ~ white crystallite or lump, or white powder.

Identification (1) Potassium Phosphate, Tribasic solution (1→20) is alkaline.

(2) Potassium Phosphate, Tribasic solution (1→20) responds to test of potassium salts and Phosphate in Identification.

Purity (1) Water Insoluble substances : Potassium Phosphate, Tribasic proceed as directed under Purity

(1) in 「Trisodium Phosphate」. The content of water insoluble substances should not be more than 0.2%.

(2) pH : 1 g of Potassium Phosphate, Tribasic is dissolved in 100 mL of water. pH of this solution should be within a range of 11.5~12.5.

(3) Arsenic : It should be no more than 4.0 ppm tested by Arsenic Limit Test.

(4) Lead : Potassium Phosphate, Tribasic is precisely weighed and is tested by purity (2) for 「Sodium Metaphosphate」, its content should not be more than 4.0 ppm.

(5) Cadmium : Potassium Phosphate, Tribasic is precisely weighed and is tested by purity (3) for 「Sodium Metaphosphate」, its content should not be more than 1.0 ppm.

(6) Mercury : When Potassium Phosphate, Tribasic is tested by Mercury Limit Test, its content should not be more than 1.0 ppm.

(7) Fluoride : 1 g of Potassium Phosphate, Tribasic is precisely weighed and is tested by purity (8) for 「Calcium Citrate」, its content should not be more than 10 ppm.

Loss on Ignition When Potassium Phosphate, Tribasic is first dried at 120°C and further heat-treated at 300~400°C for 1 hour, weight loss should not be more than 23%.

Assay Approximately 2 g of Potassium Phosphate, Tribasic, previously heat treatment and accurately weighed, dissolve in 50 mL of water. The solution is kept at 15°C and titrated with 1N hydrochloric acid (Indicator : 3 ~ 4 drops of Methyl Orange.Xylene Cyanol FF solution).

1 mL of 1 N hydrochloric acid = 106.13 mg K_3PO_4

Potassium Polyphosphate

Chemical Formula: $(KPO_3)_n$

INS No.: 451(ii), 452(ii)

Synonyms: Potassium metaphosphate; Potassium
polymetaphosphate; Kurrol salt

CAS No.: 68956-75-2
7790-53-6

Compositional Specifications of Potassium Polyphosphate

Content Potassium Polyphosphate when calculated on the dried basis, should contain within a range of 43.0 ~ 76.0% of phosphorus pentaoxide ($P_2O_5 = 141.95$).

Description Potassium Polyphosphate occurs as white fibrous crystals or powder, or as colorless to white glassy flakes or lumps.

Identification (1) Potassium Polyphosphate responds to yields pale violet by the test for Flame Coloring Test.

(2) Dissolve 0.1 g of Potassium Polyphosphate and 0.4 g of sodium acetate in 10 mL of water, add diluted acetic acid to make slightly acidic, and add 3 mL of silver nitrate solution. A white precipitate is formed.

Purity (1) Clarity and Color of Solution : To 1 g of Potassium Polyphosphate, add 4 g of sodium acetate, dissolved in 100 mL water. This solution should be colorless and slightly turbid.

(2) Chloride : When 0.1 g of Potassium Polyphosphate is tested by Sulfate Limit Test, its content should not be more than the amount that corresponds to 0.3 mL of 0.01 N hydrochloric acid.

(3) Sulfate : Weigh 0.1 g of Potassium Polyphosphate, and add 30 mL of water and 2 mL of diluted hydrochloric acid. Dissolve while boiling for 1 minute, cool, and add water to make 50 mL. This solution is tested by Chloride Limit Test, its content should not be more than the amount that corresponds to 0.2 mL of 0.01 N sulfuric acid.

(4) Orthophosphate : Weigh 1 g of Potassium Polyphosphate, and add 2 ~ 3 drops of silver nitrate solution. No brilliant yellow color develops.

(5) Arsenic : It should be no more than 2.0 ppm tested by Arsenic Limit Test.

(6) Lead : Potassium Polyphosphate is tested by purity (2) for 「Sodium Metaphosphate」(not more than 4.0 ppm).

(7) Cadmium : Potassium Polyphosphate is tested by Purity (3) for 「Sodium Metaphosphate」(not more than 1.0 ppm).

(8) Mercury : When Potassium Polyphosphate is tested by Mercury Limit Test, its content should not be more than 1.0 ppm.

(9) Fluoride : 1 g of Potassium Polyphosphate is tested by purity (8) for 「Calcium Citrate」(not more than 10 ppm).

Loss on Drying When Potassium Polyphosphate is dried for 4 hours at 110°C, the weight loss should not be more than 5%.

Assay To 0.5 g of Potassium Polyphosphate, previously dried and accurately weighed, add 25 mL of nitric acid and 60 mL of water, boiled for 30 minutes and cooled, and water is added to make 100 mL solution. 20 mL of this solution is mixed with 15 mL of magnesia solution, which is neutralized with ammonia water. Additional 15 mL of ammonia water is added and the solution is set-aside for 4 hours. Precipitate is filtered and washed with ammonia (1→4) until the filtrate does not show a reaction of chloride. It is then heat-treated until the weight becomes constant. It is then weighed as $Mg_2P_2O_7$.

$$\text{Content of } P_2O_5(\%) = \frac{\text{weight of } Mg_2P_2O_7(\text{mg}) \times 0.6379 \times 5}{\text{Weight of the sample}(\text{mg})} \times 100$$

Potassium Pyrophosphate

Chemical Formula: $K_4P_2O_7$

Molecular Weight: 330.35

INS No.: 450(v)

Synonyms: Tetrapotassium pyrophosphate;
Tetrapotassium diphosphate

CAS No.: 7320-34-5

Compositional Specifications of Potassium Pyrophosphate

Content Potassium Pyrophosphate, when calculated on the dried basis, should contain not less than 95.0% of potassium pyrophosphate ($K_4P_2O_7$).

Description Potassium Pyrophosphate occurs as colorless to white crystalline powder or lumps, or as a white powder.

Identification (1) Dissolve 0.1 g of Potassium Pyrophosphate in 10 mL of water and 2~3 drops of nitric acid, and add 1 mL of silver nitrate solution. A white precipitate is formed.

(2) 1 g of Potassium Pyrophosphate is dissolved in 20 mL of water and filtered. The filtrate responds to the test for potassium salt.

Purity (1) Water Insoluble substances : 10 g of Potassium Pyrophosphate is tested by Purity (1) for 「Acidic Sodium Pyrophosphate」 and its content should not be more than 0.2% .

(2) Clarity and Color of Solution : 1 g of Potassium Pyrophosphate is dissolved in 100 mL of water. pH of this solution is pH 10.0~10.7.

(3) Arsenic : It should be no more than 4.0 ppm tested by Arsenic Limit Test.

(4) Lead : Potassium Pyrophosphate is precisely weighed and is tested by purity (2) for 「Sodium Metaphosphate」 (not more than 4.0 ppm).

(5) Cadmium : Potassium Pyrophosphate is precisely weighed and is tested by purity (3) for 「Sodium Metaphosphate」 (not more than 1.0 ppm).

(6) Mercury : When Potassium Pyrophosphate is tested by Mercury Limit Test, its content should not be more than 1.0 ppm.

(7) Fluoride : 1 g of Potassium Pyrophosphate is tested by purity (8) for 「Calcium Citrate」 (not more than 10 ppm).

Loss on Drying When Potassium Pyrophosphate is dried for 4 hours at 105°C and strongly heated for 30 minutes at 550°C, the weight loss should not be more than 2.0%.

Assay Approximately 600 mg of Potassium Pyrophosphate is dissolved in 100 mL of water. pH of the solution is adjusted to 3.8 with hydrochloric acid, where 50 mL of zinc sulfate solution [125 g of 7-hydrated zinc sulfate is dissolved in water to bring the total volume to 1,000 mL. It is filtered and its pH is adjusted to 3.8] is added. After 2 minutes, pH is adjusted to 3.8 by titrating free acids with 0.1 N sodium hydroxide solution. However, near the end point, precipitated zinc hydroxide should be

redissolved after adding sodium hydroxide solution.

1 mL of 0.1 N sodium hydroxide solution = 16.52 mg $K_4P_2O_7$

Potassium Sodium L-Tartrate

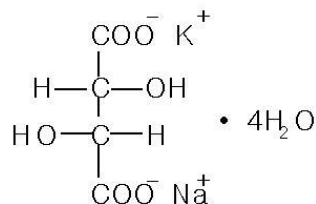

Chemical Formula: $\text{C}_4\text{H}_4\text{KNaO}_6 \cdot 4\text{H}_2\text{O}$

Molecular Weight: 282.23

INS No.: 337

Synonyms: Sodium potassium tartrate; Rochelle salt;
Seignette salt

CAS No.: 304-59-6

Compositional Specifications of Potassium Sodium L-Tartrate

Content Potassium Sodium L-Tartrate, when calculated on the dried basis, should contain not less than 99.0% of Potassium Sodium L-Tartrate ($\text{C}_4\text{H}_4\text{KNaO}_6$).

Description Potassium Sodium L-Tartrate occurs as colorless crystals or as a white crystal, crystalline powder.

Identification (1) 1 g of Potassium Sodium L-Tartrate is soluble in 1 mL of water but insoluble in ethanol.
(2) Potassium Sodium L-Tartrate responds to the test for Sodium Salt, Potassium Salt, and Tartrate in Identification.

Purity (1) pH: When Potassium Sodium L-Tartrate proceeds as directed under glass electrode method, pH of Potassium Sodium solution (1→10) should be within a range of 6.5~7.5.
(2) Oxalic acid : When 2 mL of calcium chloride solution and several drops of dilute acetic acid are added to 10 mL of an aqueous solution (1→10) of Potassium Sodium L-Tartrate, the solution should be clear within 1 hour.
(3) Arsenic: It should be no more than 4.0 ppm tested by Arsenic Limit Test.
(4) Lead : When 5.0 g of Potassium Sodium L-Tartrate is tested by Atomic Absorption Spectrophotometry or Inductively Coupled Plasma Emission Spectroscopy, its content should not be more than 2.0 ppm.
(5) Mercury : When Potassium Sodium L-Tartrate is tested by Mercury Limit Test, its content should not be more than 1.0 ppm.

Loss on Drying When Potassium Sodium L-Tartrate is dried for 3 hr at 150°C, the weigh loss should be within a range of 21.0~26.0%.

Assay Dissolve 0.5g of Potassium Sodium L-Tartrate, previously dried and accurately weighed, in 50 mL of glacial acetic acid, 30 mL of 96% formic acid, and 45 mL of anhydrous acetic acid by warming until the solution is dissolved completely. Titrate with 0.1N perchloric acid solution until the solution is green

in color(Indicator: crystal violet-glacial acetic acid solution). Perform blank test with the same method separately.

1 mL of 0.1N perchloric acid solution = 14.11 mg $C_4H_4KNaO_6 \cdot 4H_2O$

Potassium Sorbate



Chemical Formula: $\text{C}_6\text{H}_7\text{O}_2\text{K}$

INS No.: 202

Molecular Weight: 150.22

CAS No.: 24634-61-5

Compositional Specifications of Potassium Sorbate

Content Potassium Sorbate, when calculated on the dried basis, should contain within a range of 98.0 ~ 101.0% of Potassium Sorbate ($\text{C}_6\text{H}_7\text{O}_2\text{K}$).

Description Potassium Sorbate occurs as white to light yellow-brown flaky crystals, crystalline powder or granules. It is odorless or has a slight odor.

Identification (1) To 1 mL of Potassium Sorbate solution (1→100), add 1 mL of acetone. Add drop wise diluted hydrochloric acid to make the solution slightly acidic, add 2 drops of bromine solution, and shake. The color of the solution disappears immediately.

(2) Potassium Sorbate responds to the test of Potassium Salt in Identification.

Purity (1) Clarity and Color of Solution : When 0.2 g of Potassium Sorbate is dissolved in 5 mL of water, the color of the solution should not be darker than the Color Standard Solution F.

(2) Free Alkali : Dissolve 1 g of Potassium Sorbate in 20 mL of freshly boiled and cooled water, and add 2 drops of phenolphthalein solution. Even if a red color develops, the color disappears on addition of 0.4 mL of 0.1 N sulfuric acid.

(3) Chloride : Dissolve 1 g of Potassium Sorbate in about 30 mL of water, and add 11 mL of diluted nitric acid while shaking well. Filter, wash with water, and combine the filtrate and the washings. Its content should not be more than the amount that correspond to 0.5 mL of 0.01 N hydrochloric acid.

(4) Sulfate : Dissolve 0.5 g of Potassium Sorbate in about 30 mL of water, and add 3 mL of diluted hydrochloric acid while shaking well. Filter, wash with water, and combine the filtrate and the washings. Its content should not be more than the amount that correspond to 0.4 mL of 0.01 N sulfuric acid.

(5) Arsenic : It should be no more than 4.0 ppm tested by Arsenic Limit Test.

(6) Lead : When 5.0 g of Potassium Sorbate is tested by Atomic Absorption Spectrophotometry or Inductively Coupled Plasma Emission Spectroscopy, its content should not be more than 2.0 ppm.

(7) Mercury : When Potassium Sorbate is tested by Mercury Limit Test, its content should not be more than 1.0 ppm.

(8) Aldehyde : To 3.0g of Potassium Sorbate, add 450 mL of water, adjust pH of this solution to 4 using hydrochloric acid(1→12). Then water is added to make 500 mL and filtered, Test Solution. Separately, water is added to 2.5mL of 40% formaldehyde solution to make 1,000mL. 3 mL of this solution is

precisely measured and water is added to make 500 mL, Reference Solution. To 5 mL of each of test solution and reference solution, 2.5 mL of puccine sulfite solution is added. Then set aside the solution for 15~30 minutes. The color of test solution should not be deeper than that of reference solution. (not more than 0.1% as formaldehyde).

Loss on Drying When Potassium Sorbate is dried for 3 hours at 105°C, the weight loss should not be more than 1%.

Assay Accurately weigh about 0.3 g of Potassium Sorbate, previously dried, add 50 mL of acetic acid for nonaqueous titration, and titrate with 0.1 N perchloric acid (indicator: 10 drops of α -naphtholbenzein solution) until the brown color of the solution changes to green.

1 mL of 0.1 N perchloric acid = 15.02 mg of $C_6H_7O_2K$

Potassium Sulfate

Chemical Formula: K_2SO_4

INS No.: 515(i)

Molecular Weight: 174.26

CAS No.: 7778-80-5

Compositional Specifications of Potassium Sulfate

Content Potassium Sulfate should contain within a range of 99.0 ~ 100.5% of potassium sulfate (K_2SO_4).

Description Potassium Sulfate is colorless ~ white crystallite or crystalline powder with bitter taste.

Identification Potassium Sulfate solution (1→10) responds to test of potassium salts in Identification.

Purity (1) Lead : Potassium Sulfate is precisely weighed and is tested by purity (2) for 「Sodium Metaphosphate」, its content should not be more than 2.0 ppm.

(2) Arsenic : It should be no more than 4.0 ppm tested by Arsenic Limit Test.

(3) Mercury : When Potassium Sulfate is tested by Mercury Limit Test, its content should not be more than 1.0 ppm.

(4) Selenium : 1 g of Potassium Sulfate is dissolved in 100 mL (Test Solution). The Test Solution is analyzed with Cold Vapor Type of atomic absorption spectrophotometer. The absorption should not be higher than that of the Standard Solution (Not more than 30 ppm). The Standard Solution is prepared by diluting 3 mL of selenium standard solution to 100 mL with water.

Assay Approximately 0.5 g of Potassium Sulfate is precisely weighed and dissolved in 200 mL of water. After adding 1 mL of hydrochloric acid, the solution is boiled. While stirring continuously, 8 ~ 9 mL of barium chloride solution is slowly added. The resulting solution is heated for 1 hour in a water bath. After cooling, the solution is filtered through a quantitative filter paper. The precipitates are washed until the filtrate doesn't show the reaction of chlorides. The precipitates are then carbonized carefully and heat-treated at $800 \pm 25^\circ\text{C}$ until the weight becomes constant. It is then weighed as barium sulfate.

$$\text{Content(\%)} = \frac{\text{weight of barium sulfate(g)} \times 0.7466}{\text{weight of the sample(g)}} \times 100$$

L-Proline



Chemical Formula: $C_5H_9NO_2$

Molecular Weight: 115.13

Synonyms: L-2-Pyrrolidinecarboxylic acid

CAS No.: 147-85-3

Compositional Specifications of L-Proline

Content L-Proline, when calculate on the dried basis, the content should contain within a range of 98.5~101.5% of L-proline ($C_5H_9NO_2$).

Description L-Proline is scentless white crystallite or crystalline powder with a slightly sweet taste.

Identification When 1 mL of ninhydrine solution (0.2→100) is added to 5 mL of L-Proline solution (1→1,000), this solution becomes yellow.

Purity (1) Specific Rotation : 4 g of pre-dried L-Proline is precisely weighed and dissolved in water so that the total volume becomes 100 mL. The polarity of this solution should be within a range of $[\alpha]_D^{20}$
= -84.0~-86.3°

(2) Lead : When 5.0 g of L-Proline is tested by Atomic Absorption Spectrophotometry or Inductively Coupled Plasma Emission Spectroscopy, its content should not be more than 5ppm.

(3) Arsenic : It should be no more than 4.0 ppm tested by Arsenic Limit Test.

(4) Chloride: When 0.07 g of L-Proline is tested by Chloride Limit Test, its content should not be more than the amount that corresponds to 0.2 mL of 0.01 N hydrochloric acid.(Not be more than 0.1%)

Loss on Drying After drying for 3 hours at 105°C, the loss weight should not be more than 0.3%.

Residue on Ignition Residue after ignition should not be more than 0.1%.

Assay Dissolve about 0.22 g of L-Proline, previously dried and accurately weighed in 3 mL of formic acid and 50 mL of glacial acetic acid. The solution is titrated with 0.1 N perchloric acid solution (indicator : 2 drops of crystal violet solution in glacial acetic acid). The end point is where the color of the solution turns bluish green. Separately, a blank test is carried out by following the same procedure.

1 mL of 0.1 N perchloric acid solution = 11.51 mg $C_5H_9NO_2$

Propionic Acid

Chemical Formula: $C_3H_6O_2$

Molecular Weight: 74.08

INS No.: 280

Synonyms: Ethylformic acid; Methylacetic acid;
Propanoic acid

CAS No.: 79-09-4

Compositional Specifications of Propionic Acid

Content Propionic Acid, when calculated on the dried basis, should contain within a range of 99.5 ~ 100.5% of propionic acid ($C_3H_6O_2$).

Description Propionic Acid is an oily, clear liquid having a characteristic odor.

Purity (1) Specific Gravity : Specific gravity should be within a range of 0.993 ~ 0.997

(2) Distillation Range : When Propionic Acid is tested for boiling point and amount of distillate, 95%(v/v) or more should be extracted at 138.5~142.5°C.

(3) Lead : When 5.0 g of Propionic Acid is tested by Atomic Absorption Spectrophotometry or Inductively Coupled Plasma Emission Spectroscopy, its content should not be more than 2.0 ppm.

(4) Arsenic : It should be no more than 4.0 ppm tested by Arsenic Limit Test.

(5) Mercury : When Propionic Acid is tested by Mercury Limit Test, its content should not be more than 1.0 ppm.

(6) Aldehyde (as propionic aldehyde) : 10 mL of Propionic Acid is transferred into a Erlenmeyer flask with a ground-glass stopper, containing 50 mL of water and 10 mL of sodium hydrogen sulfite solution (1→80). Shake vigorously, allow to stand for 30 minutes and titrate with 0.1 N iodine until the color of the solution becomes to yellow-brown. The consumed volume is not more than 1.75 mL. Separately, perform a blank test in the same manner.

(7) Readily Oxidizable substances (as formic acid) : 15 g of sodium hydroxide is dissolved in 50 mL of water and cooled. 6 mL of Bromine is added while stirring and water is added to make 2,000 mL. 25 mL of this solution is transferred into the Erlenmeyer flask with a stopper with 100 mL of water. 10 mL of sodium acetate solution(1→5) and 10 mL of hydrochloric acid are added and allow to stand for 15 minutes. 5 mL of potassium iodide solution(1→4) and 10 mL of hydrochloric acid are added to this solution, and titrated with 0.1N sodium thiosulfate solution until the brown color immediately disappear. The consumed amount should not be more than 2.2 mL. Separately, perform a blank test in the same manner.

(8) Residue on Evaporation : 0.01% and lower after evaporating the 100 mL propionic acid and drying it at 105°C for half an hour or until being weighted.

Water Content When Propionic Acid is tested by Water Determination Method (Karl-Fischer Method), the content should not be more than 0.15%.

Assay Accurately weigh about 1.5 g of Propionic Acid, dissolve in 100 mL of freshly boiled and cooled water, and titrate with 0.5 N sodium hydroxide (indicator : 2 drops of phenolphthalein solution).

1 mL of 1 N sodium hydroxide = 37.04 mg of $C_3H_6O_2$

Propyl Gallate

Gallic Acid, Propyl Ester



Chemical Formula: $C_{10}H_{12}O_5$

Molecular Weight: 212.21

INS No.: 310

Synonyms: Gallic acid, propyl ester

CAS No.: 121-79-9

Compositional Specifications of Propyl Gallate

Content Propyl Gallate, when calculated on the dried basis, should contain within a range of 98.0 ~ 102.0% of propyl gallate ($C_{10}H_{12}O_5$).

Description Propyl Gallate occurs as a white to light brown-yellow crystalline powder. It is odorless and has a light bitter taste.

Identification (1) Dissolve 0.5 g of Propyl Gallate in 10 mL of sodium hydroxide solution, distill, and take about 4 mL of the initial distillate. The distillate is clear. An scent of propyl alcohol is evolved upon heating.

(2) Dissolve 0.1 g of Propyl Gallate in ethanol to make 5 mL. Add 1 drop of dilute ferric chloride solution. The color becomes purple.

Purity (1) Melting Point : Melting point of Propyl Gallate, previously dried for 2 hours at 105°C, should be within a range of 146 ~ 150°C.

(2) Clarity and Color of Solution : Dissolve 0.5 g of Propyl Gallate in 10 mL of ethanol. The color of the solution should not be deeper than that of Color standard Solution C.

(3) Chloride : To 1.5 g of Propyl Gallate, add 75 mL of water, warm for 5 minutes to about 70°C, cool to about 20°C, and filter. To 25 mL of the filtrate, add 6 mL of dilute nitric acid, which is then tested by Chloride Limit Test. The content of the solution should not be more than the almost corresponds to 0.4 mL of 0.01 N sulfuric acid.

(4) Sulfate : To 25 mL of the filtrate in (3) above, add 1 mL of dilute hydrochloric acid, which is then tested by Sulfate Limit Test. Its content should not be more than the amount that corresponds to 0.4 mL of 0.01 N sulfuric acid.

(5) Arsenic : It should be no more than 4.0 ppm tested by Arsenic Limit Test.

(6) Lead : When 5.0 g of Propyl Gallate is tested by Atomic Absorption Spectrophotometry or Inductively Coupled Plasma Emission Spectroscopy, its content should not be more than 2.0 ppm.

(7) Mercury : When Propyl Gallate is tested by Mercury Limit Test, its content should not be more than 1.0 ppm.

Loss on Drying When Propyl Gallate is dried for 2 hours at 105°C, the weight loss should not be more than 1.5%.

Residues on Ignition When thermogravimetric analysis is done with 1 g of Propyl Gallate, the residue should not be more than 0.1%.

Assay Dry a glass filter (1G4) at 110°C for 30 minutes. allow to cool in a vacuum desiccator, and cool and accurately weigh. Accurately weigh about 0.2 g of Propyl Gallate, previously dried. add 150 mL of water, and boil. Add 50 mL of bismuth nitrate solution while stirring forcefully, stir for several minutes more, filter the precipitate through the above glass filter, wash twice with 5 mL of diluted nitric acid (1→300) cooled in ice water, and wash with ice water until the blue litmus paper does not change to red. Dry at 110°C for 3 hours, allow to cool in a vacuum desiccator, Accurately weigh, and calculate the content by the following formula

$$\text{Content of propyl gallate(C}_{10}\text{H}_{12}\text{O}_5\text{)(\%)} = \frac{\text{Weight of the precipitate(g)} \times 0.486}{5} \times 100$$

Weight of the sample(g)

Propylene Glycol

Chemical Formula: $C_3H_8O_2$

INS No.: 1520

Molecular Weight: 76.10

Synonyms: Methyl glycol; Propanediol;

CAS No.: 57-55-6

Propane-1,2-diol

Compositional Specifications of Propylene Glycol

Content Propylene Glycol should contain not less than 98.0% of propylene glycol ($C_3H_8O_2$).

Description Propylene Glycol is a colorless, clear, viscous liquid. It is odorless and has a slightly bitter and sweet taste.

Identification (1) When thin plate chromatography is carried out with 5 μ l of a solution of Propylene Glycol in methyl alcohol (1 \rightarrow 10) using a mixture of methyl alcohol and propylene glycol (10:1) as a reference solution and n-butyl alcohol methyl alcohol chloroform (5:3:2) as a developing solvent. A yellow spot is observed at the position as the reference. In this case, silica gel for thin layer chromatography (with phosphor) that is dried for 1 hour at 110°C is used as a porous support material. It is developed until the solvent front reaches approximately 15 cm from the starting point. It is then dried in air, heated for 10 minutes to remove solvent, and colorized by spraying thymol sulfuric acid solution and drying for 20 minutes at 110°C.

(2) To 1 mL of Propylene Glycol, add 0.5 g of potassium hydrogen sulfate, and heat. A fruity odor is evolved.

Purity (1) Specific Gravity : Specific gravity of Propylene Glycol should be within a range of 1.036 ~ 1.040.

(2) Boiling Point : Boiling Point of Propylene Glycol should be within a range at 185 ~ 189°C.

(3) Free Acid : To 50 mL of water, add 1 mL of phenolphthalein solution, add sodium hydroxide solution (1 \rightarrow 2,500) until the pink color of the solution persists for 30 seconds, add 10 mL of Propylene Glycol, mix, and add 0.20 mL of 0.1 N sodium hydroxide. A pink color persists for not less than 30 seconds.

(4) Arsenic : It should be no more than 4.0 ppm tested by Arsenic Limit Test.

(5) Lead : When 5.0 g of Propylene Glycol is tested by Atomic Absorption Spectrophotometry or Inductively Coupled Plasma Emission Spectroscopy, its content should not be more than 2.0 ppm.

Water Content Water content of Propylene Glycol as determined by water content determination method (Karl-Fischer Method) should not be more than 0.2%.

Residue on Ignition When thermogravimetric analysis is done with 10 g of Propylene Glycol, the residue should not be more than 0.07%.

Assay Accurately weigh about 1 g of Propylene Glycol. and add water to make exactly 250 mL. Take 10

mL of this solution, transfer into a flask with a ground-class stopper. add 10 mL of sodium metaperiodate solution (1→40), accurately measured. add 4 mL of diluted sulfuric acid (1→2). shake well, and allow to stand for 40 minutes. Weigh 5 g of potassium iodide to the solution. add, immediately stopper tightly, shake well, allow to stand in a dark place for 5 minutes, and titrate with 0.1 N sodium thiosulfate (indicator : starch solution). Perform a blank test in the same manner.

1 mL of 0.1 N sodium thiosulfate solution = 3.8048 mg $C_3H_8O_2$

Propylene Glycol Alginate

Chemical Formula: $(C_9H_{14}O_7)_n$ (esterified)

Equiv wt, actual(avg.) : 234.21

INS No.: 405

Synonyms: Hydroxypropyl alginate

CAS No.: 9005-37-2

Compositional Specifications of Propylene Glycol Alginate

Description Propylene Glycol Alginate occurs as a white to yellowish ~ white coarse or fine powder. It is odorless.

Identification To 1 g of Propylene Glycol Alginate, add 100 mL of water to produce a pasty solution. Proceed the following tests using this solution as test solution.

- (1) To 5 mL of the test solution, add 5 mL of lead acetate solution. It immediately solidifies into a gelatinous state.
- (2) To 10 mL of the test solution, add 1 mL of sodium hydroxide solution, heat in a water bath for 5 ~ 6 minutes, cool, and add 1 mL of diluted sulfuric acid. It immediately solidifies to a gelatinous state.
- (3) To 1mL of the test solution, add 4 mL of water, and shake vigorously. Effervescence persists.

Purity (1) Arsenic : It should be no more than 4.0 ppm tested by Arsenic Limit Test.

(2) Lead : When 5.0 g of Propylene Glycol Alginate is tested by Atomic Absorption Spectrophotometry or Inductively Coupled Plasma Emission Spectroscopy, its content should not be more than 5.0 ppm.

(3) Cadmium : When 5.0 g of Propylene Glycol Alginate is tested by Atomic Absorption Spectrophotometry or Inductively Coupled Plasma Emission Spectroscopy, its content should not be more than 1.0 ppm.

(4) Mercury : When Propylene Glycol Alginate is tested by Mercury Limit Test, its content should not be more than 1.0 ppm.

(5) Total Propylene Glycol : Transfer 1 g of Propylene Glycol Alginate, precisely dried and accurately weighed, into a 400 mL beaker, and dissolve in 100 mL distilled water. Add 50 mL of 0.1N sodium hydroxide solution and stir for 30 min. At the end of this period, neutralize with 0.1N hydrochloric acid and precipitate the gum with 25 mL of a 5% calcium chloride solution. Filter the mixture using filter paper collecting the filtrate in a 250 mL volumetric flask. Wash the precipitate with several small portions of distilled water combining the washing with the filtrate and dilute to 250 mL with distilled water, test solution. Pipette a 25 mL aliquot of the test solution and 25 mL of the periodic acid solution into a 250mL conical flask, swirl and let stand for 30 min. At the end of this period, add 2 g of potassium iodide and titrate with 0.1N sodium thiosulfate using 1% starch solution as an indicator. Perform a blank determination using 50 mL of distilled water and 25 mL of the periodic acid solution. The content of total Propylene Glycol calculated by the following equation. Its contest should be within a range of 15~45%.

$$\text{Propylene Glycol(\%)} = \frac{3.8 \times (A - B)}{W}$$

A : 0.1 N sodium thiosulfate consumed used for a blank (mL)

B : 0.1 N sodium thiosulfate consumed used for test solution (mL)

W : Weight of the sample (g)

Periodic Acid Solution : To 5.5 g of iodic acid, add 200 mL of water add glacial acetic acid to make 1,000mL.

(6) Free Propylene Glycol : Accurately weigh 2 g of Propylene Glycol Alginate, previously dried, transfer it into flask and add 80 mL of isopropyl alcohol, attach a reflux condenser, heat for 3 hours in a water bath. Allow the solution to cool to room temperature, then determine the quantity of free propylene glycol as described under the procedure for (5) Purity. This content of total Propylene glycol should not be more than 15 %.

(7) Degree of Esterification : Degree of Esterification of Propylene Glycol Alginate is calculated by the following equation and its value should not be less than 75%.

$$\text{Degree of Esterification (\%)} = 100 - (a + b + c)$$

a, b, and c are obtained from ①, ②, and (8).

a : content of free alginic acid (%)

b : content of sodium alginate (%)

c : content of insoluble ash (%)

① Free Alginic Acid : Accurately weigh about 0.5 g of Propylene Glycol Alginate, previously dried for 4 hours at 105°C, dissolve it in 200 mL of freshly boiled and cooled water, add 2 drops of phenolphthalein solution, and titrate with 0.02 N sodium hydroxide until the pink color persists for about 20 seconds. Calculate the content by the following formula.

$$\text{Content of free alginic acid(\%)} = \frac{\text{Volume of 0.02N sodium hydroxide consumed(mL)} \times 0.00352}{\text{weight of the sample(g)}} \times 100$$

② Sodium Alginate : Accurately weigh about 1 g of Propylene Glycol Alginate Alginate, previously dried for 4 hours at 105°C, proceed as directed under Assay in Alkaline Salt of Organic Acid. In this case, 20 mL of 0.1 N sulfuric acid and 0.1 N sodium hydroxide solution are used instead of 50 mL

of 0.5 N sulfuric acid and 0.5 N sodium hydroxide solution. The content of sodium alginate is calculated by the following formula (indicator : 3 drops of methyl red solution).

Content of sodium alginate (%)=

$$\frac{\text{Volume of 0.1N sulfuric acid consumed(mL)} \times 0.0198}{\text{weight of the sample(g)}} \times 100$$

(8) Insoluble ash : Dry the residue on the filter paper obtained in above ②. Ignite to constant weight, cool, and accurately weigh. The content of Insoluble ash should not be more than 1.5%.

(9) Total Viable Aerobic Count : When Propylene Glycol is tested by Microbe Test Methods for Total Viable Aerobic Count (Number of General Germs) in General Test Method in 「Standards and Specifications for Foods」, it should not be more than 5,000 per 1 g.

(10) E. coli : When Propylene Glycol is tested by Microbe Test Methods for E. coli in General Test Method 「Standards and Specifications for Foods」, it should be negative (-).

(11) Salmonella : When Propylene Glycol is tested by Microbe Test Methods for Salmonella in General Test Method 「Standards and Specifications for Foods」, it should be negative (-).

(12) Fungi : When Propylene Glycol is tested by Microbe Test Methods for Fungi in General Test Method in 「Standards and Specifications for Foods」, it should not be more than 500 per 1 g

Loss on Drying When Propylene Glycol Alginate is dried for 4 hours at 105°C, the weight loss should not be more than 20%.

Propylene Glycol Esters of Fatty Acids

Synonyms: Propane-1,2-diol esters of fatty acids

INS No.: 477

Compositional Specifications of Propylene Glycol Esters of Fatty Acids

Description Propylene Glycol Esters of Fatty Acids occur as white to light yellow-brown powders, flakes, granules, waxy lumps or viscous liquids. They are odorless or have a slight, characteristic odor.

Identification (1) 100 mL of alcoholic solution of KOH is added to 10 g of Propylene Glycol Esters of Fatty Acids, which is heated for 1 hour in a water bath with a reflux condenser. Most of alcohol is then distilled out. After cooling, 50 mL of dilute hydrochloric acid is added to precipitate fatty acids. Fatty acids are removed by extracting twice with 50 mL each of petroleum ether. The solution is extracted 10 times with 30 mL each of ether. Extracts are combined and dehydrated with anhydrous sodium sulfate. Ether is evaporated out in a water bath. 0.3 g of the residue is again distilled in 3 mL of pyridine and 2.1 g of triphenylchloromethane in a water bath using a reflux condenser. After cooling, 60 mL of warm acetone is added to dissolve solid. 0.06 g of activated carbon is added and mixed, which is filtered. Filtrate is concentrated to one half of the initial volume in a water bath. It is then stored in a refrigerator. Crystals formed are collected and dried for 3 hours at 105°C. The melting point is 173~179°C.

(2) To 0.1 g of Propylene Glycol Esters of Fatty Acids, add 2 mL of ethanol, dissolve while warming, add 5 mL of diluted sulfuric acid, heat in a water bath for 30 minutes, and cool. Oil drops or white to yellow-white solids are formed. Separate the oil drops or solids, add 3 mL of ether, and shake. They dissolve.

Purity (1) Acid Value : Approximately 5 g of Propylene Glycol Esters of Fatty Acids is precisely weighed and heated and dissolved in 100 mL of alcohol, test solution. When this test solution is proceeded as directed under Acid Value in Fats Test, the value should not be more than 4.

(2) Arsenic : It should be no more than 4.0 ppm tested by Arsenic Limit Test.

(3) Polyoxyethylene : To 1 g of Propylene Glycol Esters of Fatty Acids, add 20 mL of water, heat, mix well, and cool it down. Add 10 mL of ammonium thiocyanate-nitric acid cobalt test solution, shake, and mix it well. Again, add 10 mL of chloroform, mix well, and allow to stand. Then the chloroform layer should not turn blue.

(4) Lead : When 5.0 g of Propylene Glycol Esters of Fatty Acids is tested by Atomic Absorption Spectrophotometry or Inductively Coupled Plasma Emission Spectroscopy, its content should not be more than 2.0 ppm.

(5) Cadmium : When 5.0 g of Propylene Glycol Esters of Fatty Acids is tested by Atomic Absorption Spectrophotometry or Inductively Coupled Plasma Emission Spectroscopy, its content should not be more than 1.0 ppm.

(6) Mercury : When Propylene Glycol Esters is tested by Mercury Limit Test, its content should not be more than 1.0 ppm.

Residue on Ignition When thermogravimetric analysis is done with 1 g of Propylene Glycol Esters of Fatty Acids, the residue should not be more than 1.5%.

Protease

Definition Protease(Fungal), protease(Bacterial) and protease(Plant) are included in this Protease. Definition of each protease is as follows.

Protease(Fungal) is an enzyme obtained from cultures of *Aspergillus niger* and its variety, *Aspergillus oryzae* and its variety, and *Aspergillus melleus* and its variety. Dilutant or stabilizer can be added for the purpose of activity adjustment and quality preservation.

Protease(Bacterial) is an enzyme obtained from cultures of *Bacillus subtilis* and its variety, *Bacillus licheniformis* and its variety and *Bacillus stearothermophilus* and its variety, and *Bacillus amyloliquefaciens* and its variety. Dilutant or stabilizer can be added for the purpose of activity adjustment and quality preservation.

Protease(Plant) is an enzyme obtained from plants such as papain, ficin, and bromelain etc., Dilutant or stabilizer can be added for the purpose of activity adjustment and quality preservation.

I. Protease(Fungal)

Compositional Specifications of Protease(Fungal)

Description Protease, Fungal, is white ~ dark brown powder, particle, paste or colorless ~ dark brown liquid.

Identification When Protease, Fungal is proceeded as directed under Activity Test, it should have the activity as Protease, Fungal.

Purity (1) Arsenic : It should be no more than 4.0 ppm tested by Arsenic Limit Test.

(2) Lead : When 5.0 g of Protease, Fungal, is tested by Atomic Absorption Spectrophotometry or Inductively Coupled Plasma Emission Spectroscopy, its content should not be more than 5.0 ppm.

(3) Coliform Group : When Protease, Fungal, proceed as directed under Microbe Test Methods for Coliform Group in General Test Methods「Standards and Specifications for Foods」, it should not contain more than 30 cfu per 1 g of this product.

(4) Salmonella : When Protease, Fungal, proceed as directed under Microbe Test Methods for Salmonella in General Test Methods 「Standards and Specifications for Foods」, it should be negative (-).

(5) E. Coli : When Protease, Fungal, proceed as directed under Microbe Test Methods for E. Coli in General Test Methods 「Standards and Specifications for Foods」, it should be negative (-).

Activity Test (Activity) The method is to measure the amount of Protease, and tested as directed under Method 1 SAP(Spectrometric acid protease unit) and Method 2 HUT(Hemoglobin unit on the throsine basis). However, protease obtained from *Aspergillus melleus* should be examined by the Method 2.

Method 1 SAP(Spectrometric acid protease unit)

•Analysis Principle : This test is to measure the activity of protease (expressed as SAP: Spectrophotometric acid protease units). Activity test is based on hydrolysis of casein substrate for 30 minutes, at pH 3.0,

37°C. Unhydrolyzed substrate is precipitated with trichloroacetic acid and removed by filtration. The amount of casein dissolved in the filtrate is determined by the absorption measurement.

- Preparation of Test Solution : Test Solution is prepared so that the corrected absorption at 275 nm of isothermalized enzyme filtrate (defined as ΔA in this test) will be within a range of 0.200 ~ 0.500 using 2 mL of the final dilution with glycine hydrochloric acid buffer solution. Sample is precisely weighed and ground in a glass mortar with glycine hydrochloric acid buffer solution. It is then transferred into a volumetric flask and filled with glycine hydrochloric acid buffer solution.
- Test Procedure : 10 mL each of substrate solution is added to a 25×150 mm test tube, per 1 sample, test tubes for enzyme test should not be more than 2 , 1 for enzyme blank test, and 1 for substrate blank test. Each test tube is capped and maintained for 15 minutes in a water bath at $37 \pm 0.1^\circ\text{C}$. Precisely 2 mL of Test Solution is added to the test tube, well mixed, and allowed to settle in a water bath (note: Test Tube should be capped while isothermalizing.). For substrate blank test, 2 mL glycine hydrochloric acid buffer solution is added instead of Test Solution. After exactly 30 minutes, the reaction of enzyme is stopped by adding 10 mL of trichloroacetic acid solution. For enzyme blank test, 10 mL of substrate solution, 10 mL of trichloroacetic acid, and 2 mL of Test Solution are sequentially added. Protein is completely coagulated by heating all the test tubes in a water bath at $37 \pm 0.1^\circ\text{C}$. The test tubes are cooled for 5 minutes in an ice bath. The contents are filtered through Whatman No.42 filter paper or its equivalent. The filtrate should be completely clear. Absorbance of the filtrate is measured at 275 nm with 1 cm cell using the filtrate in the substrate blank test as a reference. Absorbance of enzyme Test Solution is corrected by subtracting the absorbance of enzyme blank test solution from the absorbance of enzyme test solution.

Standard Curve

181.2 mg of L-tyrosine (previously dried until the weight becomes constant) is precisely weighed and completely dissolved in 60 mL of 0.1 N hydrochloric acid. This solution is diluted to 1,000 mL with water. 1 mL of the resulting solution contains 1 μmol of tyrosine. Using this solution, diluted solutions that contain 0.10, 0.20, 0.30, 0.40, and 0.50 μmol each per 1 mL are prepared. Using water as a reference, absorbance of each solution is measured at 275 nm with 1 cm cell. An absorbance calibration curve for the amount(μmol) of tyrosine per mL is prepared. This should be a straight line. The slope and intercept are obtained for the following calculation. It should be near 1.38. The slope and intercept is obtained by least square method as follows below.

$$\text{Slope}(S) = \frac{n\sum(MA) - \sum(M)\sum(A)}{n\sum(M^2) - (\sum M)^2}$$

$$\text{Intercept}(I) = \frac{\sum(A)\sum(M^2) - \sum(M)\sum(MA)}{n\sum(M^2) - (\sum M)^2}$$

n : Number of data points on the standard curve
M : Amount(μmol) of tyrosine per mL for each data point
A : Absorbance for each concentration of Standard Solution

Enzyme activity is calculated by the following equation.

$$\text{SAP/g} = (\Delta A - I) \times \frac{22}{S \times 30 \times W}$$

ΔA : Corrected absorbance of isothermalized enzyme filtrate
I : Intercept of the standard curve
22 : Amount of final reaction liquid (mL)
S : Slope of the standard curve
30 : Reaction time (minutes)
W : Weight of sample contained in 2 mL of Test Solution (g)

Definition of Activity : 1 Spectrophotometric acid protease unit(SAP) corresponds to the activity that frees 1 μmol of tyrosine per minute under the above test conditions.

Solutions

- Casein : Casein (Hammarsten) is used.
- Glycine Hydrochloric Acid Buffer Solution (0.05 M) : 3.75 g of glycine is dissolved in about 800 mL of water, where pH is adjusted to 3.0 with 1 N hydrochloric acid. It is diluted to 1,000 mL with water.
- Trichloro Acetic Acid Solution : 18.0 g of trichloroacetic acid and 11.45 g of sodium acetate are dissolved in 800 mL of water, where 21.0 mL of glacial acetic acid is added. It is diluted to 1,000 mL with water.
- Substrate Solution : 8 mL of 1 N hydrochloric acid is added to 500 mL of water, where 7.0 g of casein (dried basis) is dispersed by stirring continuously. It is then heated for 30 minutes in a boiling water bath while stirring occasionally. After cooling to room temperature, 3.75 g of glycine is added to the solution. pH of the resulting is adjusted to 3.0 with 0.1 N hydrochloric acid. It is diluted to 1,000 mL with water.

Method 2 HUT(Hemoglobin units on the tyrosine basis)

- Analysis Principle : This test is to measure the activity of protease (expressed as HUT: Hemoglobin units on the tyrosine basis). Activity test is based on hydrolysis of Hemoglobin substrate for 30 minutes, pH

4.7 at 40°C. Unhydrolyzed substrate is precipitated with trichloroacetic acid and removed by filtration. The amount of Hemoglobin dissolved in the filtrate is determined by the absorbance measurement.

- Preparation of Test Solution : Test Solution is prepared by dissolving the sample in acetate buffer solution so that 1 mL of the final dilution contains 9 ~ 22 HUT (absorbance as measured by the Test Procedure will be within a range of 0.2 ~ 0.5).
- Test Procedure : 10 mL each of substrate solution is added to a 25 × 150 mm test tube for enzyme test and for substrate blank test. Each test tube is heated for 5 minutes in water bath at 40°C. 2 mL of Test Solution is added to the test tube for enzyme test and 2 mL of acetate buffer solution is added to the test tube for substrate blank test. It is placed the stopper on the test tube and diluted by tapping for 30 seconds on the palm. After heating for exactly 30 minutes in a water bath at 40°C, 10 mL of trichloroacetic acid solution is added to each tube (note : it should not be sucked in with mouth). Both tubes are capped and vigorously shaken for 40 seconds in every 10 ~ 12 minutes, which is repeated for 1 hour so that the tubes are cooled to room temperature. For enzyme blank test, 10 mL of substrate solution and about 5 mL of Test Solution are placed separately in two test tubes, which are heated for 30 minutes in a water bath. 10 mL of trichloroacetic acid solution is added to the test tube with 10 mL substrate solution, which is shaken for 40 seconds. To this solution, precisely 2 mL of the heated Test Solution is added. It is then shaken for 40 minutes in every 10 ~ 12 minutes. This is repeated for 1 hour so that the solution is cooled to room temperature. The 3 test tubes above are vigorously shaken and filtered through Whatman No.42 filter paper or its equivalent. First 3 mL of the filtrate is discarded. Absorbance of the filtrate is measured at 275 nm with 1 cm cell using the solution for the substrate blank test as a reference. Au is subtracted the absorbance of enzyme blank test solution from the absorbance of enzyme test solution (if Au does not will be within a range of this range, it is tested again with adjusted weight of sample).

Standard Curve

100.0 mg of L-tyrosine (previously dried until the weight becomes constant) is precisely weighed and completely dissolved in 60 mL of 0.1N hydrochloric acid. This solution is diluted to 1,000 mL with water. 1 mL of the resulting solution contains 1000 µg of tyrosine. Using this solution, diluted solutions that contain 75.0, 50.0, and 25.0 µg each per 1 mL are prepared. Using 0.006 N hydrochloric acid as a reference, absorbance of 4 each solution is measured at 275 nm with 1 cm cell. The slope of a curve is measured by plotting absorbance per 1 µg of tyrosine. As is obtained by multiplying the slope with 1.10. This value should be approximately 0.0084.

Enzyme activity is calculated by the following equation.

$$\text{H U T/g} = \frac{\text{Au}}{\text{As}} \times \frac{22}{30W}$$

22 : Amount of final reaction liquid (mL)

30 : Reaction time (minutes)

W : Weight of sample contained in 2 mL of Test Solution (g)

(Note : Under standardized conditions, As is obtained 0.0084. This value is used in usual tests instead of the value obtained from the standard curve. However, if an accuracy is an issue and there are any doubts, the value obtained from the standard curve should be used.)

Definition of Activity : 1 HUT unit corresponds to the amount of an enzyme that generates enzyme-decomposed matter in 1 minute that shows a similar absorbance (with 1 cm cell at 275 nm) as a solution containing 1.10 µg of tyrosine per 1 mL of 0.006 N hydrochloric acid under the above test conditions.

Solutions

- Hemoglobin : Hemoglobin substrate powder or its equivalent, that is completely soluble in water, is used.
- Acetate Buffer Solution : 136 g of sodium acetate ($\text{NaC}_2\text{H}_3\text{O}_2 \cdot 3\text{H}_2\text{O}$) is dissolved in plenty of water, which is then diluted to 500 mL with water. 25 mL of this solution and 50 mL of 1 M acetic acid are mixed and the total volume is made to 1,000 mL. pH of this solution should be 4.7 ± 0.02 .
- Substrate Solution : 4.0 g of Hemoglobin is dissolved in 100 mL of water by stirring for 10 minutes in a 250 mL beaker. pH of the solution is adjusted to 1.7 with 0.3 N hydrochloric acid while stirring (the electrode of the pH meter is immersed in the solution). After 10 minutes, pH is adjusted to 4.7 with 0.5M sodium acetate solution. The total volume is made to 200 mL with water. If this solution is stored in a refrigerator, it is effective for 5 days.
- Trichloroacetic acid solution : 140 g of trichloroacetic acid is dissolved in 75 mL of water, which is then diluted to 1,000 mL with water.

Storage Standard of Protease, Fungal (HUT)

Protease, Fungal (HUT) is stored in a cold dark place with sealing tightly.

II. Protease, Bacterial(PC)

Compositional Specifications of Protease, Bacterial(PC)

Description Protease, Bacterial (PC) is white ~ dark brown powder, particle, paste or colorless ~ dark brown liquid.

Identification When Protease, Bacterial (PC) is proceeded as directed under Activity Test, it should have the activity as Protease, Bacterial (PC).

Purity (1) Arsenic : It should be no more than 4.0 ppm tested by Arsenic Limit Test.

(2) Lead : When 5.0 g of Protease, Bacterial, is tested by Atomic Absorption Spectrophotometry or Inductively Coupled Plasma Emission Spectroscopy, its content should not be more than 5.0 ppm.

(3) Coliform Group : When Protease, Bacterial(PC) proceed as directed under Microbe Test Methods for Coliform Group in General Test Methods 「Standards and Specifications for Foods」, it should not contain more than 30 cfu per 1 g of this product.

(4) Salmonella : When Protease, Bacterial(PC) proceed as directed under Microbe Test Methods for Salmonella in General Test Methods 「Standards and Specifications for Foods」, it should be negative (-).

(5) E. Coli : When Protease, Bacterial, proceed as directed under Microbe Test Methods for E. Coli in General Test Methods 「Standards and Specifications for Foods」, it should be negative (-).

Activity Test (activity)

- Principle : This test is to measure the activity of protease (expressed as PC unit). Activity test is based on hydrolysis of casein substrate for 30 minutes, at pH 7.0, 37°C. Unhydrolyzed casein is removed by filtration. The amount of casein dissolved in the filtrate is determined by the absorbance measurement.
- Preparation of Test Solution : Test Solution is prepared using Tris buffer solution so that 2 mL of the final dilution contains 10 ~ 44 PC units.
- Test Procedure : 10 mL each of substrate solution is added to a 25 × 150 mm test tube for enzyme test, enzyme blank test, and substrate blank test. These tubes are maintained for 15 minutes in a water bath at $37 \pm 0.1^\circ\text{C}$. For enzyme test, 2 mL of Test Solution is quickly added and shaken, which is then allowed to settle in the water bath. For substrate blank test, 2 mL of Tris buffer solution, instead of Test Solution, is added. After 10 minutes, 10 mL each of trichloroacetic acid solution is added to each test tube to stop the reaction. For enzyme blank test, 10 mL each of substrate solution and trichloroacetic acid solution are added, and mixed by shaking for 40 seconds, where 2 mL of Test Solution is then added (note : trichloroacetic acid should not be sucked in with mouth). These tubes are further heated for 30 minutes in a water bath to coagulate proteins completely. At the end point, the tubes are shaken vigorously and filtered through a Whatman No.42 filter paper. Initial 3 mL of the filtrate is discarded. Absorbance of the filtrate is measured at 275 nm with 1 cm path length using the solution for the substrate blank test as a reference. Au is the value subtracted the absorbance of enzyme blank test solution from the absorbance of enzyme test solution.

Standard Curve

100.0 mg of L - tyrosine (previously dried until the weight becomes constant) is precisely weighed and completely dissolved in 60 mL of 0.1 N hydrochloric acid. This solution is diluted to 1,000 mL with water. 1 mL of the resulting solution contains 100 µg of tyrosine. Using this solution, diluted solutions that contain 75.0, 50.0, and 25.0 µg each per 1 mL are prepared. Using 0.006 N hydrochloric acid as a reference, absorbance of 4 each solution is measured at 275 nm with 1 cm cell. A standard curve is prepared using absorbance of tyrosine concentration. Absorbance of a solution that contains 60 µg of tyrosine per 1 mL is obtained by interpolation from the standard curve. This absorbance value is divided by 40, so that it represents an absorbance of a solution that contains 1.5 µg per 1 mL, A_s (which is approximately 0.0115.)

Enzyme activity is obtained by the following equation.

$$PC/g = \frac{A_u}{A_s} \times \frac{22}{30W}$$

22 : Amount of final reaction liquid (mL)

30 : Reaction time (minutes)

W : Weight of sample contained in 2 mL of Test Solution (g)

Definition of Activity : 1 Bacterial protease unit(PC) corresponds to the amount of an enzyme that generates 1.5 µg/mL of L-tyrosine per minute under the test conditions above.

Solutions

- Casein : Casein (Hammarsten) is used.
- Tris Buffer Solution (pH 7.0) : 12.1 g of Tris(Hydroxymethyl)aminomethane for enzyme test is dissolved in 800 mL of water. pH is adjusted to 7.0 with 1 N hydrochloric acid. Water is added to make the total volume to 1,000 mL.
- Trichloroacetic Acid Solution : 18 g of trichloroacetic acid and 19 g of sodium acetate (3 hydrate) are dissolved in 800 mL of water, where 20 mL of glacial acetic acid is added. It is diluted to 1,000 mL with water.
- Substrate Solution : 6.05 g of Tris(Hydroxymethyl)aminomethane for enzyme test is dissolved in 500 mL of water, where 8 mL of 1 N hydrochloric acid is mixed. 7 g of casein is added to this solution, which is heated for 30 minutes in a boiling water bath while shaking occasionally. After cooling to room temperature, pH is adjusted to 7.0 by slowly adding 0.2 N hydrochloric acid while shaking to prevent precipitation. The resulting solution is diluted to 1,000 mL with water.

Storage Standard of Protease, Bacterial(PC)

Protease, Bacterial(PC) is stored in a cold dark place with sealing tightly.

III. Plant Protease(PU)

Compositional Specifications of Plant Protease(PU)

Description Plant Protease (PU) is white ~ dark brown powder, particle, paste or colorless ~ dark brown liquid.

Identification When Plant Protease(PU) is proceeded as directed under Activity Test, it should have the activity as Plant Protease(PU).

Purity (1) Arsenic : It should be no more than 4.0 ppm tested by Arsenic Limit Test.

(2) Lead : When 5.0 g of Plant Protease, is tested by Atomic Absorption Spectrophotometry or Inductively Coupled Plasma Emission Spectroscopy, its content should not be more than 5.0 ppm.

(3) Coliform Group : When Plant Protease (PU) proceed as directed under Microbe Test Methods for Coliform Group in General Test Methods 「Standards and Specifications for Foods」, it should not contain more than 30 cfu per 1 g of this product.

(4) Salmonella : When Plant Protease (PU) proceed as directed under Microbe Test Methods for Salmonella in General Test Methods 「Standards and Specifications for Foods」, it should be negative (-).

(5) E. Coli : When Plant Protease proceed as directed under Microbe Test Methods for E. Coli in General Test Methods 「Standards and Specifications for Foods」, it should be negative (-).

Activity Test (activity)

- Application and Principle : Activity test is based on protein hydrolysis of casein substrate for 60 minutes, at pH 6.0, 40°C. Unhydrolyzed substrate is precipitated with trichloroacetic acid and removed by filtration. The amount of casein dissolved in the filtrate is determined by the absorbance measurement.
- Preparation of Test Solution : The concentration of 2 ml of final diluted solution is adjusted so that the absorbance (measured as described in Test Procedure) to be measured will be within a range of 0.2 to 0.5. Sample is ground in a mortar with phosphate cysteine EDTA buffer solution. It is then transferred into a volumetric flask and filled with the same buffer solution.
- Test Procedure : 5 mL each of casein substrate solution is added to a 25 × 150 mm test tube, 3 for enzyme test and 6 for papain standard curve). Tubes are maintained for 15 minutes in a water bath at $40 \pm 0.1^\circ\text{C}$. 2 mL of test solution and 2 mL of standard solution are added to each tube, which is mixed by shaking and again maintained for 60 minutes in a water bath. 3 mL of trichloroacetic acid solution is added to each solution. Separately, 5 mL of substrate solution and 3 mL of trichloroacetic acid solution are mixed in 9 test tubes for enzyme blank test. 2 mL of test solution and 2 mL of corresponding standard solution are added to each test tube. All the tubes are again maintained for 30 minutes in a water bath to coagulate the precipitated protein completely. It is then filtered through a Whatman No.42 filter paper or its equivalent. First 3 mL of the filtrate is discarded. Absorbance of the clear filtrate is measured at 280 nm with 1 cm cell using each blank test solution as a reference. A standard curve of absorbance of the filtrate vs. concentration of standard solution (mg/mL) is prepared. The concentration of the filtrate from test solution is obtained by interpolation on the standard curve. Enzyme activity is

calculated from the following equation.

$$\text{PU/mg} = A \times C \times 10/W$$

A : Activity of USP papain standard (PU/mg)

C : Concentration of enzyme test solution obtained from standard curve (mg/mL)

W : Weight of sample contained in 2 mL of Test Solution (mg)

Definition of Activity : 1 Papain unit(PU) is an amount of enzyme that frees 1 μg equivalent of tyrosine in 1 hour under the above test conditions.

Solutions

- Sodium Phosphate Solution (0.05 M) : 7.1 g of sodium phosphate, dibasic (anhydrous) is dissolved in 500 mL of water, which is diluted to 1,000 mL with water. 1 drop of toluene is added as a preservative.
- Citric Acid (0.05 M) : 10.5 g of citric acid (1 hydrate) is dissolved in 500 mL of water, which is diluted to 1,000 mL with water. 1 drop of toluene is added as a preservative.
- Phosphate Cysteine EDTA Buffer Solution : 7.1 g of sodium phosphate is dissolved in about 800 mL of water, where 14.0 g of EDTA (2 hydrate) and 6.1 g of cysteine hydrochloride (1 hydrate) are added and dissolved. pH of the resulting solution is adjusted to 6.0 ± 0.1 with 1 N hydrochloric acid or 1 N sodium hydroxide solution. The total volume of the solution is made to 1,000 mL with water.
- Trichloroacetic Acid : 30 g of trichloroacetic acid is dissolved in water to make total volume to 100 mL.
- Substrate Solution : 1 g of casein (Hammarsten) as a dried basis is dissolved in 50 mL of sodium phosphate solution, which is heated for 30 minutes in a boiling water bath while shaking occasionally. It is then cooled while continuously shaking and its pH is adjusted to 6.0 ± 0.1 with citric acid solution (note : if the solution is shaken continuously and rapidly, precipitates are not formed.). The resulting solution is diluted to 100 mL with water.
- Standard Solution, Stock : 100 mg of USP papain standard is dissolved in phosphate cysteine EDTA buffer solution to make total volume to 100 mL.
- Standard Solution : 2, 3, 4, 5, 6, and 7 mL each of Standard Solution(Stock) is placed in 100 mL volumetric flask. Each of the flask is filled with phosphate cysteine EDTA buffer solution.

Storage Standard of Plant Protease(PU)

Plant Protease(PU) is stored in cold dark place with sealing tightly.

Psyllium Seed Gum

Definition Psyllium Seed Gum is a polysaccharide obtained by crushing the outer shells of seeds of psyllium plant (*Plantago ovata* FORSK.) of plantaginaceae or its same species.

Compositional Specifications of Psyllium Seed Gum

Description Psyllium Seed Gum is pale light gray~yellowish brown powder with a slight characteristic scent.

Identification (1) Psyllium Seed Gum is wetted with cresol and observed under a microscope. Polygonal pillar cells surrounded by cell walls (4 ~ 6 sides) are observed.

(2) Psyllium Seed Gum is wetted with ethyl alcohol and observed under a microscope. When a few drops of water is drop-wise added, polygonal pillar cells swell quickly and mucilage migrates into the solution.

Purity (1) Arsenic : It should be no more than 4.0 ppm tested by Arsenic Limit Test.

(2) Lead : When 5.0 g of Psyllium Seed Gum is tested by Atomic Absorption Spectrophotometry or Inductively Coupled Plasma Emission Spectroscopy, its content should not be more than 10.0 ppm.

(3) Total Viable Aerobic Count : When Psyllium Seed Gum is tested by Microbe Test Methods for Total Viable Aerobic Count (Number of General Germs) in General Test Method in 「Standards and Specifications for Foods」, it should not be more than 10,000 per 1 g

(4) E. Coli : When Psyllium Seed Gum is tested by Microbe Test Methods for E. Coli in General Test Method 「Standards and Specifications for Foods」, it should be negative (-).

(5) Protein : When 3 g of Psyllium Seed Gum is precisely weighed, proceed as directed under Kjeldahl Method in Nitrogen Determination, the amount should not be more than 2.0%.

1 mL of 0.01 N sulfuric acid = 0.8754 mg protein

Loss on Drying When Psyllium Seed Gum is dried for 6 hours at 105°C, the weight loss should not be more than 12%.

Ash When Psyllium Seed Gum is tested by Ash and Acid-Insoluble Ash Limit, the amount of ash should not be more than 4.0%.

Pullulan

INS No.: 1204

Chemical Formula: $(C_6H_{10}O_5)_n$

CAS No.: 9057-02-7

Definition Pullulane is obtained by separation and purification of polysaccharides produced by black yeast (*Aureobasidium pullulans* (DE BARY) ARN.). Its major component is neutral polysaccharides.

Compositional Specifications of Pullulan

Description Pullulane is white ~ pale yellowish white powder. It may be scentless or may have a slight characteristic scent.

Identification (1) When 10 g of Pullulane is slowly mixed (in small portions at a time) into 100 mL while stirring, it becomes a viscous solution.

(2) When 0.1 mL of pullulanase solution is added to and mixed with 10 mL of the solution obtained in (1) and set aside, viscosity disappears.

(3) When 2 mL of polyethylene glycol 600 is added to 10 mL of an aqueous solution of Pullulane (1→50), white precipitates are formed immediately.

Purity (1) Viscosity : Approximately 10 g of dried Pullulane is precisely weighted and dissolved in water (total weight = 100 g). Viscosity of this solution is measured at $30 \pm 0.1^\circ\text{C}$ by 1. Capillary Viscosity Measurement in Viscosity Measurement. It should be 15 ~ 180cps.

(2) Arsenic : It should be no more than 4.0 ppm tested by Arsenic Limit Test.

(3) Lead : When 5.0 g of Pullulane is tested by Atomic Absorption Spectrophotometry or Inductively Coupled Plasma Emission Spectroscopy, its content should not be more than 1.0 ppm.

(4) Protein : When approximately 3 g of Pullulane is precisely weighted and tested by semi-micro Kjeldahl Method in Nitrogen Determination. By multiplying the amount of nitrogen with a nitrogen coefficient 6.25, the amount of protein is obtained. The content should not be more than 0.3%. However, the amount of sulfuric acid used for decomposition is 12 mL and the amount of sodium hydroxide solution (2→5) is 40 mL.

1 mL of 0.01 N sulfuric acid = 0.140 mg N

(5) Monosaccharides, disaccharides, and oligosaccharide : 0.8 g of ϵ -Polylysine is precisely weighted and water is added to make 100 mL. Transfer 1 mL of this solution into a centrifuged tube, 0.1 mL of saturated solution of potassium chloride and 3 mL of methyl alcohol are added, vigorously shaken for 20 seconds, mixed, and centrifuged at 11,000rpm for 10 minutes. 5 mL of anthrone solution is added to 0.2 mL of supernatant, immediately mixed, heated for 15 minutes in a water bath, test solution.

Absorption is measured at 620nm wavelength. Separately, 5 mL each of anthrone solution is added to 0.2 mL of standard solution and for blank test, 0.2 mL of water respectively, proceed under same procedure as test solution, and each absorption is measured. The content of monosaccharides, disaccharides, and oligosaccharide should not be more than 10% (as glucose) by the following equation.

$$\text{content of monosaccharides, disaccharides, and oligosaccharide(\%)} = \frac{(A_t - A_b) \times 0.41 \times G \times 100}{(A_s - A_b) \times W}$$

A_t : Absorption of test solution

A_b : Absorption of blank test solution

A_s : Absorption of standard solution

G : Weight of glucose

W : Weight of sample

Standard solution : 0.2g of glucose is precisely weighted and dissolved in water to make 1,000 mL.

Anthrone solution : 0.2 g of anthrone is dissolved in 100 g of 75%(v/v) sulfuric acid. This is prepared freshly before use.

(6) Coliform Group : When Pullulane is tested by Microbiological Methods for Coliform Group in General Testing Methods in 「Standards and Specifications for Foods」, it should be negative (-).

(7) Salmonella : When Pullulane is tested by Microbiological Methods for Salmonella in General Testing Methods 「Standards and Specifications for Foods」, it should be negative (-).

(8) The number of Fungi : When Pullulane is tested by Microbiological Methods for The number of Fungi in General Testing Methods in 「Standards and Specifications for Foods」, it should not be more than 100 per 1 g.

Loss on Drying When Pullulane is vacuum dried for 6 hours at 90°C, the weight loss should not be more than 8.0%.

Residue on Ignition Residue on Ignition of Pullulane should not be more than 5.0%.

Pullulanase

Definition Pullulanase is an enzyme obtained from cultures of *Bacillus acidopullulyticus*, *Klebsiella aerogenes*, culture of *Bacillus licheniformis*, *Bacillus subtilis* which contains a gene coding for pullulanase from *Pullulanibacillus naganoensis* and *Bacillus acidopullyticus*, *Bacillus subtilis* where the pullulanase gene of *Bacillus deramificans* is inserted, and *Bacillus licheniformis* where the pullulanase gene of *Bacillus deramificans* is inserted. Dilutant or stabilizer can be added for the purpose of activity adjustment and quality preservation.

Compositional Specifications of Pullulanase

Description Pullulanase is white ~ dark brown powder, particle, paste or colorless ~ deep brown liquid.

Identification When Pullulanase is proceeded as directed under Activity Test, it should have the activity as Pullulanase.

Purity (1) Arsenic : It should be no more than 4.0 ppm tested by Arsenic Limit Test.

(2) Lead : When 5.0 g of Pullulanase is tested by Atomic Absorption Spectrophotometry or Inductively Coupled Plasma Emission Spectroscopy, its content should not be more than 5.0 ppm.

(3) Coliform Group : When Pullulanase proceed as directed under Microbe Test Methods for Coliform Group in General Test Methods in 「Standards and Specifications for Foods」, it should not contain more than 30 cfu per 1 g of this product.

(4) Salmonella : When Pullulanase proceed as directed under Microbe Test Methods for Salmonella in General Test Methods in 「Standards and Specifications for Foods」, it should be negative (-).

(5) E. Coli : When Pullulanase is tested by Microbe Test Methods for E. Coli in General Test Method 「Standards and Specifications for Foods」, it should be negative (-).

Activity Test (activity)

◦ Analysis Principle : Activity test is based on absorbance measurement of reaction mixture of dinitrosalicylic acid and maltotriose which is a reducing sugar obtained by hydrolyzing α -1,6-glycosidic bond of pullulan at pH 5.0, temperature 50°C.

◦ Preparation of Test Solution : Test Solution is prepared so that the absorbance to be measured will be within a range of 0.2 ~ 0.5 under the following test method.

◦ Test Procedure : 1 mL of substrate solution is placed in a 17 × 1.5 cm test tube for enzyme test. It is allowed to stand for 5 minutes in a water bath at 50°C. 1 mL of Test Solution is added to the test tube and the mixture is reacted for 10 minutes. The reaction is stopped by adding 2 mL of 3,5-dinitrosalicylic acid solution. Separately, 1 mL of substrate solution and 2 mL of 3,5-dinitrosalicylic acid solution are added in a test tube for enzyme blank test, and 1 mL of Test Solution is added. Both test tubes are boiled for 5 minutes in a boiling water bath and cooled rapidly. 10 mL each of water is added to each test tube, which is then shaken. Using the blank enzyme test solution as a reference, absorbance of enzyme Test Solution is measured at 540 nm with 1 cm cell.

Standard Curve

1 g of maltose (standard) is precisely weighed and dissolved in water to make total volume to 100 mL. 1.0, 1.2, 1.4, 1.6, 1.8, and 2.0 mL each of these solutions diluted to 20 mL with water, use the Standard Solutions. Instead of 1 mL of Test Solution, with 1 mL of standard solution and 1 mL of water, the same procedure as the Test Solutions repeated. Using water as a reference, standard curve is prepared by plotting absorbance of each standard solution vs. concentration of standard solution (mg/mL)

Enzyme activity is calculated by the following equation

$$\text{Activity Pullulanase(units/mL)} = C \times \frac{1,000}{\text{Concentration of Test solution(mg/mL)} \times 10}$$

C : maltose concentration in enzyme Test Solution obtained from standard curve (mg/mL)

10 : reaction time

Definition of Activity : 1 Pullulanase unit is an activity which generates reducing sugar corresponding to 1 mg of anhydrous maltose per minute under the above conditions.

Solutions

- Substrate : 70 mL of water is added to 1 g of Pullulan standard, which is heated for 5 minutes and cooled. 10 mL of 1 M acetic acid sodium acetate buffer solution is added to the solution, which is then diluted to 100 mL with water
- 1 M acetic acid sodium acetate buffer solution (pH 5.0)
 - Solution A : 60 g of acetic acid is diluted to 500 mL with water.
 - Solution B : 82 g of anhydrous sodium acetate is dissolved in water to make the total volume 500 mL. 148 mL of Solution A and 352 mL of Solution B are mixed. pH of the mixture is adjusted to 5.0 using Solution A or Solution B. The total volume is made to 1,000 mL with water.
- 3,5-Dinitrosalicylic acid, DNS Solution : 1 g of DNS is dissolved in 16 mL of 10% sodium hydroxide solution. 30 g of potassium sodium tartrate(4 hydrate) and 50 mL of water are added to the solution, which is heated and diluted to 100 mL with water. This solution should be stored at 5°C used within 5 days after preparation.

Storage Standard of Pullulanase

Pullulanase is strongly hygroscopic, so should be stored in a cold dark place with sealing tightly.

Purple Sweet Potato Color

INS No.: 163

Definition Purple Sweet Potato Color is a pigment obtained by extracting tuberous roots of sweet potato (*Ipomoea batatas* POIR. and its variety) of convolvulaceae with water. Its major pigment component is anthocyanin. Dilutant, stabilizer, or solvent can be added for the purpose of color value adjustment and quality preservation.

Compositional Specifications of Purple Sweet Potato Color

Content Color value ($E_{1cm}^{10\%}$) of Purple Sweet Potato Color should be more than the indicated value.

Description Purple Sweet Potato Color is dark red liquid, paste, powder, or paste with a slight characteristic scent.

Identification (1) A solution (1→100) of Purple Sweet Potato Color in citrate buffer solution (pH 3.0) is red color and has a maximum absorption band near 530 nm.

(2) When the solution in (1) is alkalized with sodium hydroxide solution (1→25), the color changes to dark green.

Purity (1) Arsenic : It should be no more than 4.0 ppm tested by Arsenic Limit Test.

(2) Lead : When 5.0 g of Purple Sweet Potato Color is tested by Atomic Absorption Spectrophotometry or Inductively Coupled Plasma Emission Spectroscopy, its content should not be more than 8.0 ppm.

Assay (Color Value) Appropriate amount of Purple Sweet Potato Color is precisely weighted so that the absorption is within 0.3 ~ 0.7 and dissolved in citrate buffer solution with pH 3.0 so that the total volume is 100 mL (Test Solution). If necessary, the solution is centrifuged and the supernatant is used. Using citrate buffer solution with pH 3.0 as a reference solution, absorption A is measured at the maximum absorption near 530 nm with 1cm path length. Color value is obtained using the following equation.

$$\text{Color Value } (E_{1cm}^{10\%}) = \frac{A \times 10}{\text{Weight of the sample(g)}}$$

◦ Citrate buffer solution (pH 3.0)

Solution 1 : 1 l of solution containing 121g of citric acid ($C_6H_8O_7 \cdot H_2O$)

Solution 2 : 1 l of solution containing 71.6g of dibasic sodium phosphate ($Na_2HPO_4 \cdot 12H_2O$)

Solution 1 and Solution 2 are mixed well (159:41) and its pH is adjusted to 3.0.

Purple Yam Color

INS No.: 163

Definition Purple yam color is a pigment obtained by extracting tuberous roots of yam (*Dioscorea alata* Linné) of dioscoreaceae with water. Its major pigment component is cyanidin acylglucoside. Dilutant, stabilizer, or solvent can be added for the purpose of color value adjustment and quality preservation.

Compositional Specifications of Purple Yam Color

Content Color value ($E_{1cm}^{10\%}$) of Purple yam color should be more than the indicated value.

Description Purple yam color is dark red liquid, paste, powder, or paste with a slight characteristic scent.

Identification (1) A solution (1→100) of Purple yam color in citrate buffer solution (pH 3.0) is red color and has a maximum absorption band near 530 nm..

(2) When the solution in (1) is alkalized with sodium hydroxide solution (1→25), its color changes to dark green.

Purity (1) Arsenic : It should be no more than 4.0 ppm tested by Arsenic Limit Test.

(2) Lead : When 5.0 g of Purple Yam Color is tested by Atomic Absorption Spectrophotometry or Inductively Coupled Plasma Emission Spectroscopy, its content should not be more than 10.0 ppm.

Assay (Color Value) Appropriate amount of Purple yam color is precisely weighted so that the absorption is within 0.3 ~ 0.7 and dissolved in citrate buffer solution (pH 3.0) so that the total volume is 100 mL (Test Solution). If necessary, the solution is centrifuged and the supernatant is used. Using citrate buffer solution (pH 3.0) as a reference solution, absorption A is measured at the maximum absorption near 530 nm with 1cm path length. Color value is obtained using the following equation.

$$\text{Color Value } (E_{1cm}^{10\%}) = \frac{A \times 10}{\text{Weight of the sample(g)}}$$

• Citrate buffer solution (pH 3.0)

Solution 1 : 1ℓ of solution containing 121g of citric acid ($C_6H_8O_7 \cdot H_2O$).

Solution 2 : 1ℓ of solution containing 71.6g of dibasic sodium phosphate ($Na_2HPO_4 \cdot 12H_2O$).

Solution 1 and Solution 2 are mixed well (159 : 41) and its pH is adjusted to 3.0.

Quercetin

Definition Quercetin is obtained by hydrolyzing rutin with acidic aqueous solution or enzyme. Its major component is quercetin.

Compositional Specifications of Quercetin

Content If Quercetin is converted to a dehydrated form, it should contain no less than 95.0% quercetin ($C_{15}H_{10}O_7$).

Description Quercetin is yellow crystalline powder with slight characteristic scent.

Identification (1) 5 mg of Quercetin dissolve in 10 mL of alcohol. When 1 ~ 2 drops of ferric chloride solution (1→50) are added to this solution, a greenish brown band appears.

(2) When 5 mg of Quercetin dissolve in 5mL of sodium hydroxide solution (1→100), it shows yellow ~ orange in color.

(3) 5 mg of Quercetin dissolve in 5 mL of alcohol. When 2 mL of hydrochloric acid and 0.05 g of magnesium are added, the solution slowly turns red.

(4) A solution of 10 mg of Quercetin in 500 mL alcohol has maximum absorption bands near 255 nm and 370 nm.

Purity (1) Arsenic : It should be no more than 4.0 ppm tested by Arsenic Limit Test.

(2) Lead : When 5.0 g of Quercetin is tested by Atomic Absorption Spectrophotometry or Inductively Coupled Plasma Emission Spectroscopy, its content should not be more than 2.0 ppm.

Loss on Drying When Quercetin is dried for 2 hours at 135°C, the weight loss should not be more than 13.0%.

Assay Approximately 50 mg of Quercetin is precisely weighted and dissolved in methyl alcohol (total volume = 50 mL), which is filtered through a 0.5 μ m Millipore filter (Test Solution). Separately, quercetin ($C_{15}H_{10}O_7 \cdot 2H_2O$) standard is precisely weighted so that it contains 50 mg as quercetin and dissolved in methyl alcohol (total volume = 50 mL), which is filtered through a 0.5 μ m Millipore filter (Test Solution). 10 μ l each of Test and Standard Solutions are injected into a high speed liquid chromatography under the following Operation Conditions and the content of quercetin is obtained by the following equation.

$$\text{Content(\%)} = \frac{\text{weight of the standard (as quercetin)(mg)}}{\text{weight of the sample on the anhydrous basis(mg)}} \times \frac{\text{peak area of test solution}}{\text{peak area of standard solution}} \times 100$$

Operation Conditions

-Detector : UV 375 nm

-Column : μ -Bondapak C_{18} (3.9 mm \times 300 mm) or its equivalent

-Column Temperature : room temperature

-Mobile Phase : methyl alcohol : water : acetic acid (15 : 3 : 1)

-Flow Rate : 1.0 mL/min

Quillaia Extract

Synonyms: Panama bark extract; Quillay bark extract

INS No.: 999

Definition Quillaia Extract is obtained by extracting barks of quillaia (*Quillaia saponaria* MOLINA) of rosaceae with water followed by purification. Its major component is saponin. Dilutant or other food additives can be added for the purpose of quality preservation, etc.

Compositional Specifications of Quillaia Extract

Content When Quillaia Extract is quantitatively analyzed, it should contain not less than (as a partially hydrolyzed saponin) the indicated amount.

Description Quillaia Extract is pale yellow ~ brown powder or liquid with a characteristic taste.

Identification (1) 0.5 g of Quillaia Extract is dissolved in 10 mL of water. 2 μ l of this solution is spotted at 2 cm position from the bottom of thin plate of silica gel 60 (Kiesel gel 60, Merck) and dried. It is then developed up to 3cm from the plate top using a mixture of chloroform : methyl alcohol : water : acetic acid (15:10:3:1) as a developing solvent. It is then air-dried and sprayed with anisaldehyde · sulfuric acid solution, which is heated for 10 minutes at 110°C. Brown spots (with violet tint) are observed at R_f values of 0.22, 0.26, 0.29, and 0.30. The largest spot is at R_f value of 0.29.

• Anisaldehyde · sulfuric acid : 9 mL of alcohol is stir-mixed with 0.5 mL of p-anisaldehyde and 0.5 mL of sulfuric acid.

(2) 2 g of Quillaia Extract is added to a 100 mL flask, where 25 mL of 1% potassium hydroxide solution is added, a reflux condenser is attached, and heated for 2 hours. Cool and transfer the content into a beaker and neutralize to pH 5 with hydrochloric acid (1→4). It is then diluted to 50 mL with water (Test Solution). Separately, 10 mg of partially hydrolyzed saponin used in Assay is dissolved in 5 mL of water (Standard Solution). 2 μ l of each solution is tested using Thin Plate Chromatography following the procedure under Identification (1). One of the spots from the Test Solution has the same color and R_f value from the bluish gray spot of the Standard Solution.

Purity (1) Acidity : An aqueous solution (1→100) of Quillaia Extract should have a pH of 4.5~5.5 (for powder only).

(2) Arsenic : It should be no more than 2.0 ppm tested by Arsenic Limit Test.

(3) Lead : When 5.0 g of Quillaia Extract is tested by Atomic Absorption Spectrophotometry or Inductively Coupled Plasma Emission Spectroscopy, its content should not be more than 2.0 ppm.

(4) Mercury : When Quillaia Extract is tested by Mercury Limit Test, its content should not be more than 1.0ppm

Water Content Water content of Quillaia Extract as determined by water content determination method (Karl-Fischer Method) should not be more than 6%(for powder form only).

Loss on Drying When 2 g of Quillaia Extract is dried for 5 hours at 105°C, the weight loss should be

50~80% (for liquid form only).

Residue on Ignition Residue on Ignition of Quillaia Extract should not be more than 10%.

Assay Approximately 2 g (approximately 5 g for liquid) is added to a 100 mL volumetric flask, which is filled with water. Precisely 10 mL of this solution is taken into a 100 mL volumetric flask, where 10 mL of 2% potassium hydroxide solution is added, a reflux condenser is attached, and heated for 2 hours in a water bath. Cool and transfer the content into a 50 mL volumetric flask using 25 mL of ethyl alcohol. Add 0.5 mL of phosphoric acid and dilute the solution to 50 mL with water (Test Solution). Separately, 20 mg of partially hydrolyzed saponin standard is precisely weighted into a 50 mL volumetric flask and dissolved in 50v/v% ethyl alcohol. The total volume is brought up to 50 mL with 50 v/v% ethyl alcohol (Standard Solution). Inject each 20 µl of test solution and standard solution to high speed liquid chromatography under the following operation conditions. The content of partially hydrolyzed saponin is obtained by the following equation.

$$\text{Content(\%)} = \frac{B}{A} \times \frac{(S_1+S_2) \times 10}{S_T} \times 100$$

A : Amount of sample(mg)

B : Amount of standard(mg)

S_T : Peak area of partially hydrolyzed saponin in Standard Solution

S₁ : Peak area of partially hydrolyzed saponin in Test Solution

S₂ : Peak area of saponin-like matters appeared before peak of partially hydrolyzed saponin in Test Solution

Operation Conditions

-Detector : UV 210 nm

-Column : stainless steel tube with 4~6 mm inner diameter and 15~30 cm length, which is filled with 5~10 µm silylated silica gel with octadecyl group (for liquid chromatography)

-Column Temperature : 40°C

-Mobile Phase : 0.1% phosphoric acid : acetonitrile (65 : 35)

-Flow Rate : Adjusted so that the retention time of partially hydrolyzed saponin is approximately 10 minutes

Red Cabbage Color

INS No.: 163(v)

Definition Red Cabbage Color is a pigment obtained by extracting red cabbage leaves (*Brassica oleracea* Linné) with slightly acidic solution. The major component is cyanidin acylglycoside. Dilutant, stabilizer, or solvent can be added for the purpose of color value adjustment and quality preservation.

Compositional Specifications of Red Cabbage Color

Content Color value ($E_{1cm}^{10\%}$) of Red Cabbage Color should not be less than the indicated value.

Description Red Cabbage Color is deep red liquid, powder, or paste having a slight characteristic odor.

Identification (1) The Test Solution obtained in Color Value section shows red color and a absorption maximum at about 536 nm.

(2) When Test Solution in (1) is alkalinized by adding sodium hydroxide solution, colour changed deep green.

Purity (1) Arsenic : It should be no more than 4.0 ppm tested by Arsenic Limit Test.

(2) Lead : When 5.0 g of Red Cabbage Color is tested by Atomic Absorption Spectrophotometry or Inductively Coupled Plasma Emission Spectroscopy, its content should not be more than 8.0 ppm.

Assay (Color Value) Appropriate amount of Red Cabbage Color is precisely weighed so that the absorbance will fall within 0.3 ~ 0.7 and dissolved citric acid • dibasic sodium phosphate buffer solution with pH 3.0 to make 100 mL (Test Solution). If necessary, the solution is centrifuged and the supernatant is used. Using citric acid • dibasic sodium phosphate buffer solution with pH 3.0 as a reference solution, absorbance maximum A is measured at 536 nm with 1cm cell. Color value is obtained using the following equation.

$$\text{Color Value } (E_{1cm}^{10\%}) = \frac{A \times 10}{\text{weight of the sample(g)}}$$

• Citric acid-dibasic sodium phosphate buffer solution (pH 3.0)

Solution 1 : 0.1M citric acid solution : 1 L of solution containing 21.01g of citric acid ($C_6H_8O_7 \cdot H_2O$).

Solution 2 : 0.2M dibasic sodium phosphate solution : 1 L of solution containing 71.63 g of dibasic sodium phosphate ($Na_2HPO_4 \cdot 12H_2O$).

Solution 1 and Solution 2 are mixed well (159:41) and its pH is adjusted to 3.0.

Red Radish Color

INS No.: 163

Definition Red Radish Color is a pigment obtained by extracting reddish violet roots of radish (*Raphanus sativus* LINNE) of cruciferae with water or hydrated ethyl alcohol at room temperature. Its major pigment component is Pelargonidin acylglucoside of anthocyanins. Diluent and stabilizer can be added for the purpose of color value adjustment and quality preservation.

Compositional Specifications of Red Radish Color

Content Color value ($E_{1cm}^{10\%}$) of Red Radish Color should be more than the indicated value.

Description Red Radish Color is dark red powder with a slight characteristic scent.

Identification (1) Test Solution obtained in Color Value section shows red color and a maximum absorption band near 515 nm.

Purity (1) Arsenic : It should be no more than 4.0 ppm tested by Arsenic Limit Test.

(2) Lead : When 5.0 g of Red Radish Color is tested by Atomic Absorption Spectrophotometry or Inductively Coupled Plasma Emission Spectroscopy, its content should not be more than 10.0 ppm.

Assay(Color Value) Appropriate amount of Red Radish Color is precisely weighted so that the absorption is within 0.3 ~ 0.7 and dissolved in citric acid-dibasic sodium phosphate buffer solution with pH 3.0 (total volume 100 mL). 1 mL of this solution is diluted to 100 mL with citric acid-dibasic sodium phosphate buffer solution with pH 3.0 (Test Solution). If necessary, the solution is centrifuged and the supernatant is used. Using citric acid-dibasic sodium phosphate buffer solution with pH 3.0 as a reference solution, absorption A is measured at the maximum absorption near 515 nm with 1cm path length. Color value is obtained using the following equation.

$$\text{Color Value}(E_{1cm}^{10\%}) = \frac{A \times 1,000}{\text{weight of the sample(g)}}$$

◦ Citric acid-dibasic sodium phosphate buffer solution (pH 3.0)

Solution 1 : 0.1 M citric acid solution : 1 L of solution containing 21.01 g of citric acid ($C_6H_8O_7 \cdot H_2O$).

Solution 2 : 0.2 M dibasic sodium phosphate solution : 1 L of solution containing 71.63 g of dibasic sodium phosphate ($Na_2HPO_4 \cdot 12H_2O$).

Solution 1 and Solution 2 are mixed well (159:41) and its pH is adjusted to 3.0.

D-Ribose

Definition D-Ribose is obtained by the following process. Glucose is fermented by *Bacillus* (*Bacillus pumilus*). The resulting material is separated and purified. Its component is D-Ribose.

Compositional Specifications of D-Ribose

Content D-Ribose (converted to an anhydrous form) contains 90.0~102.0% of D-ribose ($C_5H_{10}O_5 = 150.13$).

Description D-Ribose is white ~ pale brown crystalline powder. It may be scentless or have a slight characteristic scent.

Identification (1) When 2 ~ 3 drops of an aqueous solution (1→20) of D-Ribose is added to 5 mL of warm Fehling solution, red precipitates are formed.

(2) An aqueous solution of D-Ribose (1→25) is levorotatory.

Purity (1) Arsenic : It should be no more than 4.0 ppm tested by Arsenic Limit Test.

(2) Lead : When 5.0 g of D-Ribose is tested by Atomic Absorption Spectrophotometry or Inductively Coupled Plasma Emission Spectroscopy, its content should not be more than 10.0 ppm.

(3) Other Saccharide : Liquid chromatography is carried out according to Assay. All the peaks until a double retention time of D-ribose are observed. Peak area Apart from peak area of D-ribose in Test Solution, peak area should not be more than 10% of the sum of areas of all the peak.

Water Content Water content of D-Ribose is determined by direct titration method in Water Determination (Karl Fisher Method) and should not be more than 5.0%.

Residue on Ignition When thermogravimetric analysis is done with 1 g of D-Ribose, the amount of the amount of Residue on Ignition should not be more than 1.0%.

Assay Weigh accurately 1.0 g of D-Ribose and 1.0 g of D-ribose standard. Dissolve each samples in water, and dilute to 50 mL with water (Test Solution and Standard Solution). 10 μ L of each solution is injected into liquid chromatography under the following Operation Conditions and the content of D-ribose is obtained by the following equation.

$$\text{Content (\%)} = \frac{\text{weight of the standard on the anhydrous basis(g)}}{\text{weight of the sample on the anhydrous basis(g)}} \times \frac{A_T}{A_S} \times 100$$

A_T : peak area of Test Solution

A_S : peak area of Standard Solution

Operation Conditions

-Detector : Differential refractometer (RI detector)

- Column : Shodex SUGAR SC1011(8 × 300 mm) or its equivalent
- Column Temperature : 80°C
- Mobile Phase : Water
- Flow Rate : 1.0 mL/min

Rice Bran Wax

INS No.: 908

CAS No.: 8016-60-2

Definition Rice Bran Wax is obtained by separating and purifying rice bran oil of rice (*Oryza sativa* L.) of gramineae, and major component is myricyl lignocerate.

Compositional Specifications of Rice Bran Wax

Description Rice Bran Wax is pale yellow~pale brown flakes or solid with a slight characteristic scent.

Identification (1) 1~2 mg of Rice Bran Wax is analyzed by Potassium Bromide fining process in Infrared Spectrophotometry (1). Its spectrum is shown below.

Purity (1) Melting Point : Melting point of rice bran oil should be within 70~83°C.

(2) Free Fatty Acid : Approximately 7 g of is precisely weighted into a 250 mL of Erlenmeyer flask, where 75 mL of warm neutralized ethanol and 2 mL of phenolphthalein TS are added. It is titrated with 0.25 N sodium hydroxide solution until the red color persists for 30 seconds. The amount of free fatty acid (as oleic acid) is obtained by the following equation and it should not be more than 10%.

$$\text{Free fatty acid (as oleic acid)} = \frac{V \times N \times 28.2}{W}$$

V : Consumed amount of 0.25 N sodium hydroxide solution (mL)

N : Normality of 0.25 N sodium hydroxide solution

W : Amount of sample (g)

(3) Saponification Value : 3 g of Rice Bran Wax is precisely weighted into a flask and dissolved in 25 mL of xylene by shaking until the solution becomes clear or slightly turbid, where 50 mL of ethyl alcohol and 25 mL of 0.5 N alcoholic solution of potassium hydroxide are added. Attach a reflux condenser. The solution is saponified for 2 hour in a water bath. Saponification value should be 70 ~ 160 under Saponification Value in Oils Test.

(4) Iodine Value : Approximately 1 g of Rice Bran Wax is precisely weighted into a 500 mL Erlenmeyer

flask, and 30 mL of cyclohexane is added to dissolve the sample. Add 25 mL of Weiss solution, and shake with stopper. The flask is set aside for 30 minutes in a dark place. 20 mL of potassium iodide solution and 100 mL of water (previously boiled and cooled) are added to the flask. The excess iodine is titrated with 0.1 N sodium thiosulfate solution (indicator : 1 mL of starch solution), adding the titrant gradually and shaking constantly until the yellow colour of the solution almost disappears. Add starch test solution, and continue the titration with 0.1N sodium thiosulfate solution until the blue colour disappears entirely. Calculate the iodine value by the following formula. The content should not be more than 20. Separately, a blank test is carried out by the same procedure.

$$\text{Iodine Value} = \frac{(A - B) \times 1.269 \times f}{C}$$

A : Consumed amount of 0.1 N sodium thiosulfate solution in the blank test (mL)

B : Consumed amount of 0.1 N sodium thiosulfate solution in the test for sample (mL)

f : Activity of 0.1 N sodium thiosulfate solution in this test

C : Amount of sample(g)

(5) Arsenic : It should be no more than 4.0 ppm tested by Arsenic Limit Test.

(6) Lead : When 5.0 g of Rice Bran Wax is tested by Atomic Absorption Spectrophotometry or Inductively Coupled Plasma Emission Spectroscopy, its content should not be more than 10.0 ppm.

Residue on Ignition Residue on Ignition of Rice Bran Wax should not be more than 0.3%.

Rosin

Definition Rosin is obtained by filtering and purifying secretion from barks of pine trees (*Pinus* sp.) of pinacea.

Compositional Specifications of Rosin

Description Rosin is pale yellow powder or solid..

Identification (1) 0.1 g of Rosin is dissolve in 10 mL of anhydrous acetic acid by heating in water bath. Cool the solution. When sulfuric acid is added to this solution, the color of the solution becomes reddish violet.

Purity (1) Acid Value : Approximately 1 g of Rosin is precisely weighted and dissolved in approximately 50 mL of a mixture(1:1) of alcohol and ether (neutralized with 0.1 N potassium hydroxide solution using phenolphthalein TS) to use test solution. The test solution is proceeded as directed under Acid value method in Fats and Related substances tests, and the value should be 170~190.

(2) Arsenic : It should be no more than 4.0 ppm tested by Arsenic Limit Test.

(3) Lead : When 5.0 g of Rosin is tested by Atomic Absorption Spectrophotometry or Inductively Coupled Plasma Emission Spectroscopy, its content should not be more than 2.0 ppm.

Residue on Ignition When thermogravimetric analysis is done with accurately weighted 1 g of Rosin, the amount of residue should not be more than 0.1%.

Rutin

Definition Rutin is an extract (with water or ethyl alcohol) from flower or flower bud of Japanese pagoda tree (*Sophora japonica* L.) of leguminosae, or root cortex of buck wheat (*Fagopyrum esculentum* MOENCH.) of polygonaceae, or root cortex of red bean of (*Phaseolus angularis* CW. WIGHT.). Its major component is rutin ($C_{27}H_{30}O_{16}$ = 610.51) of flavonoids. Dilutant, stabilizer, or solvent can be added for the purpose of color value adjustment and quality preservation.

Compositional Specifications of Rutin

Content Color value ($E_{1cm}^{10\%}$) of Rutin should be more than the indicated value.

Description Rutin is yellow ~ pale yellowish green liquid or powder with a slight characteristic scent.

Identification (1) Rutin is dissolve in 10 mL of ethyl alcohol. When 1 ~ 2 drops of ferric chloride solution (1→50) are added, the solution becomes greenish brown.

(2) Rutin is dissolve in 5 mL of ethyl alcohol by heating. When 2 mL of hydrochloric acid and 0.05 g of magnesium powder are added, the solution slowly becomes red.

(3) Add 500 mL of ethyl alcohol to Rutin. This solution has maximum absorption bands near 255 nm and 375 nm.

(4) 5 mL of the solution in (3) is neutralized with sodium hydroxide solution, where 3 mL of Fehling solution is added. When the resulting solution is heated for 10 minutes in a water bath, red precipitates are formed.

Purity (1) Arsenic : It should be no more than 4.0 ppm tested by Arsenic Limit Test.

(2) Lead : When 5.0 g of Rutin is tested by Atomic Absorption Spectrophotometry or Inductively Coupled Plasma Emission Spectroscopy, its content should not be more than 2.0 ppm.

Assay (Color Value) Appropriate amount of Rutin is precisely weighted so that the absorption is within 0.3 ~ 0.7 and dissolved in 10 mL of ethyl alcohol by heating. If necessary, this solution is filtered through a glass filter, which is washed with hot ethyl alcohol. The filtrate and the wash are mixed and diluted to 200 mL with ethyl alcohol. To 10 mL of this solution, 1 mL of acetic acid solution in ethyl alcohol (1.2→1,000) is added and the total volume is brought up to 100 mL with ethyl alcohol (Test Solution). A reference solution is prepared by diluting 1 mL of acetic acid solution in ethyl alcohol (1.2→1,000) to 100 mL with ethyl alcohol. Absorption A for Test Solution is measured at 375 nm with 1cm path length. Color value is obtained by the following equation.

$$\text{Color Value } (E_{1cm}^{10\%}) = \frac{A \times 200}{\text{weight of the sample(g)}}$$

Saffron Color

Definition Saffron Color is a pigment obtained by extracting dried stigma of flower of saffron (*Crocus sativus*) of iridaceae with ethyl alcohol. Its major pigment component is Crocin and Crocetin of carotenoids. Dilutant, stabilizer, or solvent can be added for the purpose of color value adjustment and quality preservation.

Compositional Specifications of Saffron Color

Content Color value ($E_{1cm}^{10\%}$) of Saffron Color should be more than the indicated value.

Description Saffron Color is yellow ~ venetian red liquid, solid, powder, or paste with a slight characteristic scent.

Identification (1) 50 v/v% ethyl alcohol solution (1→500) of this additive shows yellow color and a maximum absorption band near 430 nm.

(2) When 5 mL of sulfuric acid is added to 0.5 g of Saffron Color (if necessary, evaporated to dryness in a water bath and then cooled), it becomes deep green color, which changes to violet then to brown.

Purity (1) Arsenic : It should be no more than 4.0 ppm tested by Arsenic Limit Test.

(2) Lead : When 5.0 g of Saffron Color is tested by Atomic Absorption Spectrophotometry or Inductively Coupled Plasma Emission Spectroscopy, its content should not be more than 2.0 ppm.

(3) Nitrogen : When Saffron Color is tested by Kjeldahl Method of Nitrogen Determination, the amount should not be more than 2.0%.

(4) Water Insoluble substances : 3 g of Saffron Color is placed into an Erlenmeyer flask, which is added with approximately 100 mL of water in advance. 10 mL of dilute hydrochloric acid is added to the flask, which is then gently boiled for 15 minutes, and filtered through a glass filter (previously dried until the weight does not change). The residue on the glass filter is fully washed with hot water. The residue is dried for 2 hours at 105°C, cooled in a desiccator, and measure the content of insoluble substance. The content of water insoluble substances should not be more than 45%.

(5) Acid Insoluble Ash : When Saffron Color is tested for ash by acid insoluble ash methods in Ash and Acid-Insoluble Ash Limit, it should not be more than 1.0%.

Loss on Drying When Saffron Color is dried for 4 hours at 105°C, the weight loss should not be more than 14%.

Ash When Saffron Color is tested by total ash in Ash and Acid-Insoluble Ash Limit, the amount of ash should not be more than 8.0%.

Assay (Color Value) Appropriate amount of Saffron Color is precisely weighted so that the absorption is within 0.3 ~ 0.7 and dissolved in 50 v/v% ethyl alcohol (total volume 100 mL). 1 mL of this solution is diluted to 100 mL with 50 v/v% ethyl alcohol (Test Solution). If necessary, the solution is centrifuged and the supernatant is used. Using 50 v/v% ethyl alcohol as a reference solution, absorption A is measured at the maximum absorption near 430 nm with 1cm path length. Color value is obtained using the following equation.

$$\text{Color Value } \left(E_{1\text{cm}}^{1\%} \right) = \frac{A \times 1,000}{\text{weight of the sample(g)}}$$

Sandalwood Red

INS No.: 166

CAS No.: 1397-70-2

Definition Sandalwood Red is a pigment obtained by extracting tree of sandalwood (*Pterocarpus santalinus* .Linné) of salilcaceae with water. Its major pigment component is Santalin of flavonoids. Dilutant, stabilizer, or solvent can be added for the purpose of color value adjustment and quality preservation.

Compositional Specifications of Sandalwood Red

Content Color value ($E_{1cm}^{10\%}$) of Sandalwood Red should be more than the indicated value.

Description Sandalwood Red is dark red ~ reddish violet liquid or powder with a slight characteristic scent.

Identification (1) When 0.1 g of Sandalwood Red is mixed with 100 mL, it is turbid. When the mixture is alkalinized with sodium hydroxide solution, it becomes clear reddish violet solution.

(2) When 10 mL of ammonium chloride solution (1→50) is added to a solution of Sandalwood Red (0.1 g dissolved in 100 mL of 80 v/v% ethyl alcohol), it becomes turbid and venetian red color.

(3) When 1 mL of ferric sulfate solution (1→10) is added to a solution of Sandalwood Red(0.1 g dissolved in 100 mL of 80 v/v% ethyl alcohol), it becomes brown with bluish tint and precipitates are formed.

(4) A solution of Sandalwood Red in 80 v/v% ethyl alcohol (pH 6.0) shows maximum absorption bands at 475 nm and 503 nm.

Purity (1) Arsenic : It should be no more than 4.0 ppm tested by Arsenic Limit Test.

(2) Lead : When 5.0 g of Sandalwood Red is tested by Atomic Absorption Spectrophotometry or Inductively Coupled Plasma Emission Spectroscopy, its content should not be more than 10.0 ppm.

Assay (Color Value) Appropriate amount of Sandalwood Red is precisely weighted so that the absorption is within 0.3 ~ 0.7 and dissolved in 80 v/v% ethyl alcohol so that the total volume is 100 mL (Test Solution). If necessary, the solution is centrifuged and the supernatant is used. Using 80 v/v% ethyl alcohol as a reference solution, absorption A is measured at the maximum absorption near 500 nm with 1cm path length. Color value is obtained using the following equation.

$$\text{Color Value } (E_{1cm}^{10\%}) = \frac{A \times 10}{\text{weight of the sample(g)}}$$

Seed Malt

Definition There are crude seed malt and powdered seed malt. Crude seed malt is obtained from a culture where starter of *Aspergillus kawachii*, *Aspergillus oryzae*, *Aspergillus usamii*, *Aspergillus shirousamii*, *Aspergillus awamori* or *Rhizopus* genus are separately or mixedly inoculated so that spores are inserted into a pasteurized raw material containing food-grade starch. Powdered seed malt is obtained by collecting pure spawn spores by a special method.

Compositional Specifications of Seed Malt

Description Seed Malt is yellow ~ blackish brown or yellow ~ green powder or granule having a slight characteristic odor.

Purity (1) Arsenic : It should be no more than 2.0 ppm tested by Arsenic Limit Test.

(2) Lead : When 5.0 g of Seed Malt is tested by Atomic Absorption Spectrophotometry or Inductively Coupled Plasma Emission Spectroscopy, its content should not be more than 2.0 ppm.

(3) Number of Spores : 1~2 g of Seed Malt is precisely weighed and mixed with 10 mL of 5% Tween 80 solution and 2~3 drops of 1% methylene blue solution, which is analyzed 5 times with blood cell counter and microscope. An average value of 5 times measurements is A, and the number of spores is calculated from the following equation. For crude seed malt, there should be 40×10^8 , 20×10^8 , 10×10^8 , 10×10^8 , and 10×10^8 or more starters per g for *Aspergillus kawachii*, *Aspergillus oryzae*, *Aspergillus usamii*, *Aspergillus shirousamii*, and *Aspergillus awamori*, respectively (0 for *Rhizopus* genus). For powdered seed malt, there should be 200×10^8 , 100×10^8 , 50×10^8 , 50×10^8 , and 50×10^8 or more starters per g for *Aspergillus kawachii*, *Aspergillus oryzae*, *Aspergillus usamii*, *Aspergillus shirousamii*, and *Aspergillus awamori*, respectively (0 for *Rhizopus* genus).

$$\text{Number of Spores} = \frac{A \times \text{dilution factor}}{\text{weight of the sample(g)}}$$

(4) Various Germs (*Penicillium* Genus) : 0.15~0.2 g of Seed Malt is cultured in pre-pasteurized liquid culture medium (55 mL of water, 0.025 g of mono potassium phosphate, and 1 g of dextrin are added to a 300 mL Erlenmeyer flask, which is plugged with cotton and pasteurized for 20 minutes under high pressure of 15 psi) for 5 days in a 30°C thermostat. When it is observed under microscope, test result for various germs (*Penicillium* genus) should be negative. If various germs (*Penicillium* genus) is observed (cultured for 5 hours as described above), it is positive. If not, it is cultured for additional 24 hours. If *penicillium* is observed, it is positive. If not, it is negative.

Loss on Drying When 5 g of Seed Malt is dried for 4 hours at 105°C, the weight loss should not be more than 10% for crude seed malt and more than 8% for powdered seed malt.

Sepia Color

Definition Sepia Color is a pigment obtained from the contents of ink sac of cuttlefish (*Sepia officinalis* Linnaeus). Its major component is Eumelanin. Dilutant, stabilizer, or solvent can be added for the purpose of color value adjustment and quality preservation.

Compositional Specifications of Sepia Color

Description Sepia Color is blackish brown ~ black powder or dispersion with a characteristic scent.

Identification When 0.1 g of Sepia Color is added to 10 mL of mixture (1:1) of sulfuric acid and nitric acid, it becomes yellowish brown.

Purity (1) Arsenic : It should be no more than 4.0 ppm tested by Arsenic Limit Test.

(2) Lead : When 5.0 g of Sepia Color is tested by Atomic Absorption Spectrophotometry or Inductively Coupled Plasma Emission Spectroscopy, its content should not be more than 10.0 ppm.

L-Serine

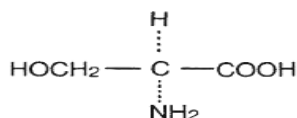

Chemical Formula: C₃H₇NO₃

Molecular Weight: 105.09

CAS No.: 56-45-1

Compositional Specifications of L-Serine

Content L-Serine, when calculated on the dried basis, should contain within a range of 98.5~101.5% of L-serine (C₃H₇NO₃).

Description L-Serine is scentless white crystalline powder with sweet taste.

Identification (1) When 1 mL of ninhydrine solution (0.2→100) is added to 5 mL of L-Serine solution (1→1,000), the solution becomes reddish violet ~ violet.

(2) Approximately 0.5 g of L-Serine is dissolved in 10 mL of water, where 0.2 g of periodic acid is added. Upon heating, an odor of formaldehyde is generated.

Purity (1) Specific Rotation : 10 g of pre-dried L-Serine is precisely weighed, which is dissolved in 2 N hydrochloric acid so that the total volume becomes 100 mL. Optical rotation of the solution should be within a range of $[\alpha]_D^{20} = +13.6 \sim +16.0^\circ$.

(2) Lead : When 5.0 g of L-Serine is tested by Atomic Absorption Spectrophotometry or Inductively Coupled Plasma Emission Spectroscopy, its content should not be more than 5.0 ppm.

(3) Arsenic : It should be no more than 4.0 ppm tested by Arsenic Limit Test.

(4) Chloride: When 0.07 g of L-Serine is tested by Chloride Limit Test, its content should not be more than the amount that corresponds to 0.2 mL of 0.01 N hydrochloric acid (Not be more than 0.1%).

Loss on Drying When L-Serine is dried at 105°C for 3 hours, the weight loss should not be more than 0.3%.

Residue on Ignition Residue after ignition should not be more than 0.1%.

Assay Approximately 0.2 g is precisely weighed and dissolved in 3 mL of formic acid and 50 mL of glacial acetic acid. This solution is titrated with 0.1 N perchloric acid solution (indicator : 2 drops of crystal violet buffered in glacial acetic acid). At the end point, the solution turns to greenish blue. Separately, a blank test is done following the same procedure.

1 mL of 0.1 N perchloric acid solution = 10.51 mg C₃H₇NO₃

Sesame Seed Oil Unsaponified Matter

Definition Sesame Seed Oil Unsaponified Matter is obtained by extracting seeds (or residues after extracting oil) of sesame (*Sesamum indicum* LINNE) of pedaliaceae with alcohol. Its components are sesamin, sesamol, and sesamol.

Compositional Specifications of Sesame Seed Oil Unsaponified Matter

Content Sesame Seed Oil Unsaponified Matter (as sesamin) should contain more than the indicated content.

Description Sesame Seed Oil Unsaponified Matter is white ~ yellow crystallite or crystalline powder.

Identification (1) When Sesame Seed Oil Unsaponified Matter is tested by Assay, a sesamin peak at 285 nm is observed.

(2) A solution of 5 mg of Sesame Seed Oil Unsaponified Matter in 10 mL of methyl alcohol has maximum absorption bands at 237 nm and 287 nm.

(3) 5 mg of Sesame Seed Oil Unsaponified Matter dissolve in 10 mL of methyl alcohol (Test Solution). Separately, 1 mg of sesamin standard dissolve in 10 mL of methyl alcohol (Standard Solution). 10 µl each of Test and Standard Solutions is spotted on a silica 60F (60F254 Silica plate) for thin layer chromatography. It is developed using a mixture of chloroform : ethylether (9 : 1) as a developing solvent and blow-dried. When silica plates are observed under UV lamp, the distance from the starting line to the center of the spot (R_f) of Test Solution should be same as R_f of Standard Solution.

Purity (1) Arsenic : It should be no more than 4.0 ppm tested by Arsenic Limit Test.

(2) Lead : When 5.0 g of Sesame Seed Oil Unsaponified Matter is tested by Atomic Absorption Spectrophotometry or Inductively Coupled Plasma Emission Spectroscopy, its content should not be more than 2.0 ppm.

Loss on Drying : When 1 g of Sesame Seed Oil Unsaponified Matter is dried for 3 hours at 105°C, the weight loss should not be more than 10.0%.

Assay Approximately 5 mg of Sesame Seed Oil Unsaponified Matter is precisely weighted and dissolved in a small amount of chloroform, which is diluted to 10mL with methyl alcohol. It is then filtered through a 0.45 µm Millipore filter (Test Solution). Separately, approximately 5 mg of sesamin standard is precisely weighted and dissolved in a small amount of chloroform, which is diluted to 10 mL with methyl alcohol. It is then filtered through a 0.45 µm Millipore filter (Standard Solution). 10 µl each of Standard and Test Solutions is injected into liquid chromatography under the following Operation Conditions. The content of sesamin is obtained by the following equation.

$$\text{Content(\%)} = \frac{S_a \times \text{weight of sesamin standard(mg)}}{S_t \times \text{Weight of the sample(mg)}} \times 100$$

S_a : peak area of Test Solution

St : peak area of Standard Solution

Operation Conditions

-Detector : UV detector, 285 nm

-Column : ODS Hypersil (4.6 × 200 mm, 5 μm) or its equivalent

-Column Temperature : room temperature

-Mobile Phase : methyl alcohol : water (80 : 20)

-Flow Rate : 0.7 mL/min

Shea Nut Color

Definition Shea Nut Color is a pigment obtained by extracting (with water) fruits or spermoderms of *Butylospermum parkii* KOTSCHY. Its major pigment component is flavonoid. Dilutant, stabilizer, or solvent can be added for the purpose of color value adjustment and quality preservation.

Compositional Specifications of Shea Nut Color

Content Color value ($E_{1cm}^{10\%}$) of Shea Nut Color should be more than the indicated value.

Description Shea Nut Color is brown ~dark brown liquid, paste, powder, or paste with a slight characteristic scent.

Identification (1) Citrate buffer(pH 7.0) solution(1→100) of Shea Nut Color is brown color.

(2) When the solution in (1) is acidified by hydrochloric acid, the pigment becomes insoluble and yellowish brown precipitates are formed.

Purity (1) Arsenic : It should be no more than 4.0 ppm tested by Arsenic Limit Test.

(2) Lead : When 5.0 g of Shea Nut Color is tested by Atomic Absorption Spectrophotometry or Inductively Coupled Plasma Emission Spectroscopy, its content should not be more than 10.0 ppm.

Assay (Color Value) Appropriate amount of Shea Nut Color is precisely weighted so that the absorption is within 0.3 ~ 0.7, and dissolved in 30 mL of anhydrous sodium carbonate solution (1→200). Citric acid-dibasic sodium phosphate buffer solution with pH 7.0 is added so that the total volume is 100 mL (Test Solution). 1 mL of this solution is diluted to 100 mL with citric acid-dibasic sodium phosphate buffer solution with pH 7.0. If necessary, the solution is centrifuged and the supernatant is used. Using a mixture of 30 mL anhydrous sodium carbonate solution (1→200) and 100 mL citric acid-dibasic sodium phosphate buffer solution with pH 7.0 as a reference solution, absorption A is measured at 490 nm wavelength with 1cm path length. Color value is obtained using the following equation.

$$\text{Color Value } (E_{1cm}^{10\%}) = \frac{A \times 1,000}{\text{weight of the sample(g)}}$$

Shellac

INS No.: 904

Synonyms: Shellac, Bleached

CAS No.: 9000-59-3

Definition Shell is obtained from lac, the resinous secretion of the insect *Laccifer(Tachardia)*, *Lacca Keer* (Coccidae). White Shellac(White Shellac, Bleached Shellac, or Regular Bleached Shellac) is obtained by dissolving the lac in sodium carbonate solution, followed by bleaching with sodium hypochlorite, precipitation with dilute sulfuric acid solution, and drying; wax-free bleached shellac(refined bleached shellac, wax-free bleached shellac) is prepared by further treatment whereby is removed by filtration.

Compositional Specifications of Shellac

Description Shellac is grayish white ~ light yellow, granular or fine particule, and odorless or having a slight characteristic odor.

Identification When a few drops of ammonium molybdate solution (1 g in 3 mL sulfuric acid) are added to 50 mg of Shellac, green color is produced. When this solution is neutralized with ammonia solution, it changed to lilac.

Purity (1) Arsenic : It should be no more than 2.0 ppm tested by Arsenic Limit Test.

(2) Lead : When 5.0 g of Shellac is tested by Atomic Absorption Spectrophotometry or Inductively Coupled Plasma Emission Spectroscopy, its content should not be more than 2.0 ppm.

(3) Rosin : 2 g of Shellac is dissolved in 10 mL of dehydrated ethanol, where 50 mL of hexane is slowly added with shaking. The solution is transferred into a separatory funnel and washed two 50 mL portion of water. Take supernatant and filter it, and evaporate to dryness remaining solution on waterbath. Add 5 mL of acetic anhydride to residue, when it is necessary dissolve in water bath by heating. 20 mL of this solution is taken into bottle for colorimetry. When it is added 1 drop of sulfuric acid, it should not produce from reddish purple and purple to yellow ocher color.

(4) Wax : 10 g of Shellac is completely dissolved in 150 mL of hot water and 2.5 g of sodium carbonate into a beaker. It is then heated for 3 hours and cooled with cold water. If wax floats to the surface, it is filtered through a filter paper and washed with water. Then the wax is washed with 5 ~ 10 mL to accelerate drying. Filter paper is loosely folded and the top is bound with a piece of fine wire, which is then dried gently with the aid of gentle heat. It is then extracted with chloroform using a fat extracting soxhlet apparatus for 2 hours. After evaporating the solvent in the collector, the extract is dried for 2 hours at 105°C and weighed. The content of wax should not be more than 5.5% for white shellac and not be more than 0.2% for refined bleached shellac.

(5) Acid Value : Approximately 2 g of dried fine powder of Shellac is precisely weighed and dissolved in 50 mL of alcohol (neutralized with sodium hydroxide solution), test solution. When the sample is tested as directed under Acid Value in Oils Method, acid value should be 73 ~ 89 for while shellac and 75 ~ 91 for refined bleached shellac.

Loss on Drying When 3 g of fine powder of Shellac is dried for 4 hours at 40°C and then 15 hours in a vacuum desiccator (silica gel), the weight loss should not be more than 6% .

Silicon Dioxide

Chemical Formula: SiO₂

Molecular Weight: 60.08

INS No.: 551

Synonyms: Synthetic amorphous silica; Silica

CAS No.: 7631-86-9

Definition Silicon dioxide is noncrystalline amorphous material as observed by X-ray diffractometer. Fumed silica is prepared by vapor phase hydrolysis. sedimentation silica, silica gel, colloidal silica or hydrolyzed silica are prepared by wet chemistry.

Compositional Specifications of Silicon Dioxide

Content Silicon dioxide, when calculated on dried at 105°C for 2 hours and treated at 900~1,000°C for 1 hour, should contain not less than 99.0% silicon dioxide (SiO₂ = 60.08) for colloidal silica and not less than 94.0% of silicon dioxide for precipitated silica, silica gel, and hydrolyzed silica.

Description Silicon dioxide is white powder, particle, or colloidal liquid. It is odorless.

Identification (1) 5 mg of Silicon dioxide is transferred into a platinum crucible and 200 mg of anhydrous potassium carbonate added. The crucible is calcined with red flame of a burner for 10 minutes. After cooling, the resulting material is dissolved in 2 mL of freshly distilled water. If necessary, the solution is heated and 2 mL of ammonium molybdate solution is slowly added. The resulting solution becomes dark yellow.

(2) 1 drop of the solution in Identification (1) is dropped on a filter paper. After liquid is removed, 1 drop of o-tolidine saturated glacial acetic acid solution is dropped. After the paper is exposed to ammonia gas, a greenish blue spot is formed.

Purity (1) Arsenic : It should be no more than 4.0 ppm tested by Arsenic Limit Test.

(2) Lead : Transfer 10.0 g of Silicon dioxide, previously dried and accurately weighed, into a beaker, and add 50mL of 0.5 N hydrochloric acid. Cover it with a watch glass, boil for 15 minutes, and cool it down. Transfer it into 100~150 mL centrifuge tube and centrifuge it for 10~15 minutes until the insoluble substances are settled. Filter the supernatant through a filter paper(a Whatman No.4 filter paper or its equivalent) and transfer the filtrate to a 100 mL flask. To the residue, add 10~15 mL of hot water, mix, and centrifuge it. Filter the supernatant and add it to the filtrate. Repeat this preparation twice and add the solution to filtrate, dilute to 100 mL with water, test solution. When this test solution is tested by Atomic Absorption Spectrophotometry or Inductively Coupled Plasma Emission Spectroscopy, its content should not be more than 5.0 ppm.

(3) Mercury : Silicon dioxide, previously dried, is tested by Mercury Limit Test, its content should not be more than 1.0 ppm.

(4) Soluble Ionized Salts : After drying for 2 hours at 105°C, 5 g of Silicon dioxide is precisely weighed

and 150 mL of water is added. This is mixed for 5 minutes using a homogenizer. The resulting mixture is vacuum filtered. The filtering apparatus and the residue are rinsed with 100 mL water and the rinse water is added to the filtrate, where water is added to make 250 mL. Use this solution as the test solution. The resulting test solution is tested for conductivity using an appropriate equipment. The conductivity of the test solution should not be higher than that of a solution of 250 mg anhydrous sodium nitrite in 250 mL water.

Loss on Drying When Silicon dioxide is dried for 2 hours at 105°C, the weight loss should be no more than 2.5% for Fumed silica, no more than 7% for sedimentation silica and silica gel, no more than 70% for hydrolyzed silica, and no more than 85% for colloidal silica.

Loss on Ignition When 1 g of Silicon dioxide, previously dried at 105°C for 2 hours and accurately weighed, heat-treated at 900 ~ 1,000°C for 1 hour, the residues should not be more than 2% for colloidal silica, 8.5% for precipitated silica, silica gel and hydrolyzed silica.

Assay Approximately 1 g of Silicon dioxide is transferred into a previously weighed platinum crucible, which is then dried for 2 hours at 105°C. It is further heat-treated for 1 hour at 900~1,000°C. After cooling in a desiccator, the weight of the sample is weighed (W_1). The resulting residue is wetted with 3 ~ 4 drops of alcohol and 2 drops of sulfuric acid are added. Hydrofluoric acid is added so that the residue is immersed. It is then evaporated at 95~105°C on a hot plate. With 5 mL of hydrofluoric acid, the crucible wall is washed and it is evaporated again. The crucible is then heated with a burner until the residue turns red. After cooling in a desiccator, the weight of the final residue is weighed (W_2). The content of silicon dioxide is calculated from the following equation.

$$\text{Content of Silicon Dioxide(\%)} = \frac{W_1 - W_2}{W_1} \times 100$$

Silicone Resin

INS No.: 900a

Synonyms: Dimethylpolysiloxane; Silicone fluid;
Silicone oil; Dimethyl silicone

CAS No.: 9006-65-9

Compositional Specifications of Silicone Resin

Description Silicone Resin is a colorless ~ light grey, transparent or translucent, viscous liquid or pasty substances with almost no odor.

Identification Transfer 100 mg of Silicone Resin into platinum crucible, and add a few drops of sulfuric acid and nitric acid and heat, it burns with white smoke. A cold glass plate is placed over the white smoke to collect particles. Collected powder is transferred into a platinum crucible, where 3 g of sodium hydroxide is added. It is melted by heating. After cooling, the residues is dissolved in 50 mL of water, which is then filtered. On a filter paper, 1 drop of the resulting solution, 1 drop of ammonium molybdate solution, and 1 drop of benzidine solution are dropped. When the paper is exposed to ammonia vapor, a blue color appears.

Purity (1) Specific Gravity : Specific gravity of Silicone Resin should be within a range of 0.96 ~ 1.02.

(2) Refractive Index : Weigh accurately 20 g of Silicone Resin, and add 100 mL of hexane. Vibrate back and forth at a rate of 200 a minute for 3hours and centrifuge it at 10,000rpm for 30 minutes. Take the supernatant into a centrifuge tube, add 50 mL of hexane, disperse well to precipitate and centrifuge. Combine the supernatant and evaporate the hexane by warming on a water bath at 50~60 °C under reduced pressure. Dry it for 1 hour at 105°C and use it as a test solution. Measure the refractive index and the refractive index of extracted silicone oil should be within a range of 1.400 ~ 1.410.

(3) Viscosity : When the test solution obtained from (2) refractive index is measured by Method 1 Capillary Viscosity Measurement in Viscosity, the viscosity should be 100~1,100 mm²/s.

(4) Silicon Dioxide : When the extraction residue above (2) is dried for 1 hour at approximately 100°C, the content should not be more than 2.25 g (not more than 15 %).

(5) Arsenic : It should be no more than 4.0 ppm tested by Arsenic Limit Test.

(6) Lead : When 5.0 g of Silicone Resin is tested by Atomic Absorption Spectrophotometry or Inductively Coupled Plasma Emission Spectroscopy, its content should not be more than 5.0 ppm.

(7) Mercury : When Silicone Resin is tested by Mercury Limit Test, its content should not be more than 1.0 ppm.

Loss on Drying When Silicone Resin is dried for 4 hours at 150°C, the weight loss should not be more than 0.5%.

Smoke Flavours

Wood smoke flavours, Pyroligneous acid, Smoke condensate

Synonyms: Wood smoke flavours; Pyroligneous acid; Smoke condensates

Definition Smoke Flavors is a mixture obtained by thermally decomposing hard segments of unprocessed trees under the condition where the amount of air is limited or controlled, by distilling them in dry condition at 200 ~ 800°C, or by treating them with strong heating vapor at 300 ~ 500°C. The main compositions are carboxylic acid, compounds having the carboxyl functional, and phenol compounds. However, for quality conservation, water, plant oil, propylene glycol, and emulsifier can be added.

Compositional Specifications of Smoke Flavors

Description Smoke Flavors is black viscous semi solid ~ pale brown liquid with smoke-like pungent taste.

Purity (1) Acid value : 1 mL of Smoke Flavors is precisely weighted into a 250 mL beaker, where 100 mL of water is added. Stirred and filtered this solution . 0.1 N sodium hydroxide solution is added to the filtrate until the pH reaches 8.15 and the consumed amount is recorded. Acid value of smoke flavours is obtained by the following equation and it should be 2 ~ 20%.

$$\text{Acid value(\%)} = \frac{a \times f \times 6.005}{\text{Weight of the sample(g)}} \times \frac{100}{1,000}$$

a : consumed amount of 0.1 N sodium hydroxide solution (mL)

F : coefficient of 0.1 N sodium hydroxide solution

6.005 : Weight of acetic acid (mg) corresponding to 1 mL of 0.1 N sodium hydroxide solution

(2) Benzo(a)pyrene

Test Solution : Depending on the description of the sample, it is treated by the procedure in ① or ②.

① Liquid sample : 200 g of well mixed smoke Flavors is precisely weighted and transferred into a 1,000 mL separatory funnel with a stopcock using 100 mL of iso-octane, where 450 mL of 5.6% potassium hydroxide solution is added. It is well mixed and settled to separate phases. Iso-octane phase is collected. The aqueous layer is extracted twice with 100 mL each of iso-octane, which is added to the previous iso-octane phase. Again, the extracts are washed twice with 50 mL each of 5.6% potassium hydroxide solution, twice with 50 mL each of water, three times with 50 mL each of phosphoric acid, and three times with 100 mL each of water.

② Viscous liquid with solid precipitates or semi-solid : Approximately 25 g of well mixed smoke Flavors is precisely weighted into a 150 mL beaker. It dissolve by adding small amount of 20% potassium hydroxide solution. The resulting solution transfer into a 2,000 mL separatory funnel with a stopcock

using 250 mL of 20% potassium hydroxide solution .The beaker is washed 4 times with 50 mL each of ethyl alcohol, which is added to the separatory funnel. 400 mL of ethyl alcohol is added to the funnel and mixed well. 250mL of iso-octane is added to the funnel and mixed. It is then set aside to separate the phases. The upper iso-octane phase is collected and the lower aqueous phase transfer into another separatory funnel with a stopcock. It is then extracted twice with 200 mL each of iso-octane, which is added to the previous iso-octane phase. The extracts are washed three times with 200 mL each of 5.6% potassium hydroxide solution, three times with 200 mL each of water, three times with 200 mL each of phosphoric acid, and three times with 200 mL each of water.

Test Procedure : Iso-octane solution in (① or ②) is passed through a column (230 × 38 mm ID, filled with 60 g of Florisil at the bottom and 50 g anhydrous sodium sulfate on top) that is pre-wetted with iso-octane. The separatory funnel is washed twice with 50 mL each of hexane, which is also passed through the column. The eluted solutions are collected. Additional 75 mL of hexane is eluted through the column and added to the previous solution. It is concentrated to approximately 5 mL to remove solvent by heating in a water bath under nitrogen atmosphere. The concentrate transfer to a 50 mL flask with a glass stopcock using hexane. It is then carefully concentrated to 0.2 ~ 0.3 mL in a water bath under nitrogen atmosphere. The residue transfer into a 125 mL beaker and washed 4 times with 5 ~ 10 mL each of hot methyl alcohol. It is then vacuum filtered into a 50 mL flask. The filtrate is concentrated to 3 ~ 5 mL at 40°C using a rotary evaporator. The concentrate transfer into a 15 mL test tube and washed 3 times with 1 mL of iso-octane. It is then evaporated to dryness under nitrogen atmosphere. The residue dissolve in a mixture of acetonitrile: methyl alcohol: water (2 : 2 : 1), where the total volume is 0.25 mL (Test Solution). Separately, a Standard Solution is prepared so that 1 mL of the solution contains 0.5~4.0 μg of benzo-pyrene. 20 μl each of Test and Standard Solutions are injected into a liquid chromatography under the following operation conditions and the content of benzo-pyrene is obtained by the following equation. The content should not be more than 0.002ppm.

$$\text{Amount of benzo-pyrene(ppm)} = \text{concentrate of the standard solution } (\mu\text{g/mL}) \times \frac{\text{Au} \times \text{dilution rate}}{\text{As} \times \text{Wu}}$$

Au : peak area of Test Solution

As : peak area of Standard Solution

Wu : Weight of sample(g)

Operation Conditions

-Detector : UV 289 nm

-Column : ODS (250 × 4.6 mm) or its equivalent

-Mobile Phase : Liquid A : water

Liquid B : methyl alcohol : acetonitrile (50 : 50)

-Concentration Gradient : After a linear concentration gradient between Solution A : Solution B (20 : 80 → 0 : 100) is carried out in 20 minutes, the column is maintained for 20 minutes with 100% of Solution B. After analysis, for the purpose of column stability, a concentration change of Solution A : Solution B (0 : 100 → 20 : 80) is applied in 5 minutes to the column and then the column is maintained for 20 minutes with 80% Solution B.

-Flow Rate : 1.0 mL/min

(3) Diethyl ether : Exactly 10 g of Smoke Flavors is extracted with 1 mL of toluene in a separatory funnel with a stopcock. Mixed by shaking and then settled. Toluene phase is collected and dehydrated by adding a small amount of anhydrous sodium sulfate (Test Solution). A solution of diethyl ether in toluene with a concentration of 250 µg/mL is prepared (Standard Solution). Same amount each of both solutions is injected into gas chromatography. The content of diethyl ether is obtained by the following equation and it should not be more than 20ppm.

$$\text{Amount of diethyl ether(ppm)} = \text{concentrate of the standard solution } (\mu\text{g/mL}) \times \frac{\text{Au} \times \text{dilution rate}}{\text{As} \times \text{Wu}}$$

Au : peak area of Test Solution

As : peak area of Standard Solution

Wu : Weight of sample(g)

Operation Conditions

-Column : HP-FFAP (50 m × 320 µm × 0.5 µm) or its equivalent

-Detector : Flame Ionization Detector (FID)

-Temperature at injection hole : 150°C

-Column Temperature : 40°C

-Detector Temperature: 230°C

(4) Methyl Alcohol : 50 g of Smoke Flavors is tested by the Test Solution B of Purity (5) for 80. Paprika Extract Pigments in Food Additive Codes. The content of methyl alcohol should not be more than 50ppm.

(5) Phenol : Exactly 5 mL of 0.2% aqueous solution of Smoke Flavors is placed in a test tube. For a blank test, 5 mL of water is placed in another test tube. To each test tube, 1 mL of 0.05% copper sulfate (CuSO₄.5H₂O) solution, 5 mL of sodium borate buffer solution, and 4 drops of 2,6-Dibromo-N-chloro-

p-benzoquinoneimine solution are added. With a cap in place, each tube is vigorously shaken and set aside for exactly 10 minutes in a dark place for colorization. 10 mL each of n-butyl alcohol is added to each tube, which is then turned upside down 6 ~ 8 times without shaking. It is then centrifuged for 5 minutes at 700 rpm. Absorption of the supernatant is measured at 610 nm using the blank test solution as a reference. The content of phenol (as 2,6-dimethoxyphenol) is obtained from a standard curve and it should not be more than 16%.

Standard Curve

20 mg of 2,6-Dimethoxyphenol standard is precisely weighted and dissolved in water (total volume = 1,000 mL). Using this solution, a series of standard solutions are prepared so that each contain 1~20 µg/mL of the phenol. By following the same procedure as the Test Solution, absorptions at each concentration is measured at 610 nm and a standard curve is prepared.

Solutions

- Sodium Borate Buffer Solution : 24.8 g of sodium borate ($\text{Na}_2\text{B}_4\text{O}_7 \cdot 10\text{H}_2\text{O}$) dissolve in 900 mL of water, where pH is adjusted to 9.8 with sodium hydroxide solution. The total volume is brought up to 1,000 mL with water.
 - 2,6-Dibromo-N-chloro-p-benzoquinoneimine Solution : 40 mg of 2,6-Dibromo- N-chloro-p-benzoquinoneimine dissolve in 10 mL of methanol. This solution is prepared just before use.
- (6) Carbonyls : 1 mL of Smoke Flavors is diluted to 50 mL of carbonyl-removed alcohol. 5 mL of this solution is further diluted to 100 mL with a mixture of carbonyl-removed ethyl alcohol and toluene (1 : 9) (Test Solution). 1 mL each of Test Solution and toluene (for blank test) is placed in a flask, respectively, where 1 mL of toluene, 2 mL of saturated 2,4-DNPH solution, and 2 mL of TCA solution are added. Each test tube is covered with a glass stopper, heated for 30 minutes at 60°C, and cooled in an ice bath. 5 mL of potassium hydroxide solution and 25 mL of carbonyl-removed alcohol are added to each test tube, which is then colorized for exactly 10 minutes. Absorption is measured at 430 nm using the blank test solution as a reference. The content of carbonyl (as heptanal) is obtained from a standard curve and it should be 2~25 %.

Standard Curve

Benzene is added to precisely weighted 30 mg of heptanal standard so that the total volume is 1,000 mL. Using this solution, a series of standard solutions are prepared so that the concentrations lie within a range of 1~30 µg/mL (Standard Solutions). By following the same procedure as the Test Solution, absorptions at each concentration is measured at 430 nm and a standard curve is prepared.

Solutions

- Saturated 2,4-DNPH Solution : 0.05% 2,4-Dinitrophenylhydrazine solution in toluene is prepared. After shaking for 1 hour, it is set aside for over night. It is filtered prior to use. It should be used within 1 week.

- TCA Solution : 4% (w/v) solution of trichloroacetic acid in toluene is prepared.
 - Potassium Hydroxide Solution : 4% (w/v) solution of potassium hydroxide solution in carbonyl-removed alcohol is prepared. This solution is freshly prepared before use.
- (7) Solid Content : 0.5 g (0.5 mL for liquid) of Smoke Flavors is precisely weighted and dried for 16 hours at 105°C. The total solid content should not be more than 18%.
- (8) Lead : When 5.0 g of Smoke Flavors is tested by Atomic Absorption Spectrophotometry or Inductively Coupled Plasma Emission Spectroscopy, its content should not be more than 2.0 ppm.

Sodium Acetate

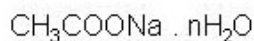

Chemical Formula: $\text{C}_2\text{H}_3\text{NaO}_2 \cdot n\text{H}_2\text{O}$ (n = 3 or 0)

INS No.: 262(i)

Molecular Weight: 3hydrates 136.08

CAS No.:

anhydrous 82.03

6131-60-4(3hydrates)

127-09-3(anhydrous)

Definition Sodium Acetate occurs as crystals (trihydrate) called Sodium Acetate (crystal) and Anhydrous called Sodium Acetate (Anhydrous).

Compositional Specifications of Sodium Acetate

Content Sodium Acetate, when calculated on the dried basis, should contain not less than 98.5% of sodium acetate ($\text{C}_2\text{H}_3\text{NaO}_2 = 82.03$).

Description Sodium Acetate (crystal) occurs as colorless, transparent crystals or as a white crystalline powder. Sodium Acetate (Anhydrous) occurs as white crystalline powder or lumps. They are odorless.

Identification (1) Heat the Sodium Acetate gradually. It fuses, then decomposes. and an odor of acetone is evolved. The aqueous solution of the residue is alkaline.

(2) Sodium Acetate responds to the tests for Sodium Salt and Acetate in Identification.

Purity (1) Clarity and Color of Solution : When 1 g of Sodium Acetate is dissolved in 20 mL of water, the solution should be colorless and clear.

(2) Free Acid and Free Alkali : Weigh 2 g of Sodium Acetate (crystal) or 1.2 g of Sodium Acetate (Anhydrous). and dissolve in 20 mL of freshly boiled and cooled water. Add 2 drops of phenolphthalein solution, keep the solution at 10°C, and perform the following test

① If the solution is colorless, add 0.1 mL of 0.1 N sodium hydroxide. A red color develops.

② If the solution is red, add 0.1 mL of 0.1 N hydrochloric acid. The color disappears.

(3) Arsenic : It should be no more than 4.0 ppm tested by Arsenic Limit Test.

(4) Lead : When 5.0 g of Sodium Acetate is tested by Atomic Absorption Spectrophotometry or Inductively Coupled Plasma Emission Spectroscopy, its content should not be more than 2.0 ppm.

(5) Mercury : When Sodium Acetate is tested by Mercury Limit Test, its content should not be more than 1.0 ppm.

Loss on Drying When Sodium Acetate is dried for 4 hours at 120°C, the weigh loss should be within a range of 36 ~ 42% and 2% or lower for crystalline form and anhydrous form, respectively.

Assay Accurately weigh about 0.2 g of Sodium Acetate, previously dried, dissolve in 40 mL of acetic acid, and titrate with 0.1 N perchloric acid. The end point is usually confirmed by using a potentiometer. When an indicator (indicator : 1 mL of crystal violet acetic acid solution) is used, titrate until the color

of the solution changes from purple through blue to green. Perform a blank test in the same manner, and make any necessary correction.

1 mL of 0.1 N perchloric acid = 8.203 mg of $C_2H_3NaO_2$

Sodium Alginate

INS No.: 401

Synonyms: Sodium salt of alginate

CAS No.: 9005-38-3

Compositional Specifications of Sodium Alginate

Content Sodium Alginate, when calculated on the dried basis, should contain not less than 90.0% of sodium alginate.

Description Sodium Alginate occurs as a white to yellowish-white powder. It is almost odorless.

Identification (1) To 0.5 g of Sodium Alginate, add 50 mL of water in small portions while stirring, warm at 60 ~ 70°C for 20 minutes while stirring occasionally to make the solution homogeneous, and cool. Use this solution as the test solution.

(i) To 5 mL of the test solution, add 1 mL of calcium chloride solution. A gelatinous precipitate is formed immediately.

(ii) To 10 mL of the test solution, add 1 mL of diluted sulfuric acid (1→20). A gelatinous precipitate is formed immediately.

(iii) To 1 mL of the test solution, add 1 mL of ammonium sulfate saturated solution. No precipitate is formed.

(2) The residue on ignition of Sodium Alginate responds to the test for Sodium Salt in Identification.

Purity (1) pH : Weigh 0.5 g of Sodium Alginate, add in small portions to 50 mL of water while stirring, warm at 60 ~ 70°C for 20 minutes while stirring occasionally to make the solution homogeneous, cool and measure under glass electrode method. pH of the solution should be within a range of 6.0~8.0.

(2) Sulfate : To 0.1 g of Sodium Alginate, add 20 mL of water to make it pasty, add 1 mL of hydrochloric acid, shake well, heat in a water bath for several minutes, cool, and filter. Wash a beaker three times with 10 mL of water each time, filter the washings through the filter paper used above, combine the filtrates, and add water to make 50 mL. Measure 10 mL of this solution, and add water to make 50 mL, Test Solution. The test solution is tested by Sulfate Limit Test. To prepare Reference solution, to 0.4 mL of 0.01 N sulfuric acid, add 1 mL of hydrochloric acid (1→4) and water to make 50 mL.

(3) Arsenic : It should be no more than 4.0 ppm tested by Arsenic Limit Test.

(4) Lead : When 5.0 g of Sodium Alginate is tested by Atomic Absorption Spectrophotometry or Inductively Coupled Plasma Emission Spectroscopy, its content should not be more than 5.0 ppm.

(5) Cadmium : When 5.0 g of Sodium Alginate is tested by Atomic Absorption Spectrophotometry or Inductively Coupled Plasma Emission Spectroscopy, its content should not be more than 1.0 ppm.

(6) Mercury : When Sodium Alginate is tested by Mercury Limit Test, its content should not be more than 1.0 ppm.

- (7) Phosphate : To 0.1 g of Sodium Alginate, add in small portions to 20 mL of water while stirring, and warm at 60 ~ 70°C for 20 minutes while stirring occasionally to make the solution homogeneous. Cool, add 5 mL of diluted nitric acid (1→4) and 20 mL of ammonium molybdate solution, and warm. No yellow precipitates are formed.
- (8) Total Viable Aerobic Count : When Sodium Alginate is tested by Microbe Test Methods for Total Viable Aerobic Count (Number of General Germs) in General Test Method in 「Standards and Specifications for Foods」, it should not be more than 5,000 per 1 g
- (9) E. coli : When sodium alginate is tested by Microbe Test Methods for E. coli in General Test Method 「Standards and Specifications for Foods」, it should be negative (-).
- (10) Salmonella : When Sodium Alginate is tested by Microbe Test Methods for Salmonella in General Test Method 「Standards and Specifications for Foods」, it should be negative (-).
- (11) Fungi : When Sodium Alginate is tested by Microbe Test Methods for Fungi in General Test Method in 「Standards and Specifications for Foods」, it should not be more than 500 per 1 g

Loss on Drying When Sodium Alginate is dried for 4 hours at 105°C, the weight loss should not be more than 15%.

Residue on Ignition Sodium Alginate is dried for 4 hours at 105°C. When thermogravimetric analysis is done with approximately 1 g of Sodium Alginate, the residues should be within a range of 33 ~ 37%.

Assay Glass filter (1G4) is dried for 30 minutes at 80°C under vacuum, cooled in a desiccator, and weighed accurately. Approximately 0.5 g of Sodium Alginate, previously dried and accurately weighed, is dissolved in 10 mL of sodium hydroxide solution (1→25), 90 mL of water is added. It is filtered, if necessary. To this solution, 15 mL of hydrochloric acid (1→3) and 100 mL of 90% alcohol are added, which is well shaken and set-aside for 2 hours. It is centrifuged and the supernatant is discarded. 10 mL of 90% alcohol is added to the residues, which is well shaken and centrifuged. The supernatant is discarded. This is repeated until the supernatant does not show a reaction of chlorides. The resulting residues are filtered through the glass filter using 90% alcohol. The residue is washed with acetone, which is dried for 1 hour at 80°C under vacuum. It is set-aside in a desiccator and accurately weighed. The content is calculated by the following equation.

$$\text{Content of Sodium Alginate(\%)} = \frac{1.125 \times \text{weight of residue(g)}}{\text{weight of the sample(g)}} \times 100$$

Sodium Aluminium Phosphate, Acidic

SALP

Chemical Formula: $\text{NaAl}_3\text{H}_{14}(\text{PO}_4)_8 \cdot 4\text{H}_2\text{O}$

$\text{N a}_3 \text{ A l}_2 \text{ H}_{15} (\text{ P O}_4)_8$

Molecular Weight: 948.88

897.82

INS No.: 541(i)

Synonyms: SALP

CAS No.: 7785-88-8

Compositional Specifications of Sodium Aluminum Phosphate, Acidic

Content Sodium Aluminum Phosphate, Acidic should contain not less than 95.0% of sodium aluminum phosphate, acidic [$\text{NaAl}_3\text{H}_{14}(\text{PO}_4)_8 \cdot \text{nH}_2\text{O}$ or $\text{Na}_3\text{Al}_2\text{H}_{15}(\text{PO}_4)_8$].

Description Sodium Aluminum Phosphate, Acidic is scentless white powder.

Identification (1) Sodium Aluminum Phosphate, Acidic is insoluble in water but soluble in hydrochloric acid.

(2) Sodium Aluminum Phosphate solution, Acidic (1→10) is acidic as determined with a litmus paper.

(3) A solution of 1 g of Sodium Aluminum Phosphate, Acidic in 10 mL of diluted hydrochloric acid (1→2) responds to tests of aluminum, sodium, and Phosphate in Identification.

Purity (1) Fluoride : 1 g of Sodium Aluminum Phosphate, Acidic is precisely weighed and is tested by purity (8) for 「Calcium Citrate」, its content should not be more than 30 ppm.

(2) Arsenic : It should be no more than 4.0 ppm tested by Arsenic Limit Test.

(3) Lead : Sodium Aluminum Phosphate, Acidic is precisely weighed and is tested by purity (2) for 「Sodium Metaphosphate」, its content should not be more than 4.0 ppm.

(4) Cadmium : Sodium Aluminum Phosphate, Acidic is precisely weighed and is tested by purity (3) for 「Sodium Metaphosphate」, its content should not be more than 1.0 ppm.

(5) Mercury : When Sodium Aluminum Phosphate, Acidic is tested by Mercury Limit Test, its content should not be more than 1.0 ppm.

Loss on Ignition When Sodium Aluminum Phosphate, Acidic is heat treated at 700~800°C for 2 hours, the weight loss should be within a range of 19.5~21.0% for $\text{NaAl}_3\text{H}_{14}(\text{PO}_4)_8 \cdot 4\text{H}_2\text{O}$ and 15.0~16.0% for $\text{Na}_3\text{Al}_2\text{H}_{15}(\text{PO}_4)_8$.

Assay Approximately 2.5 g of Sodium Aluminum Phosphate, Acidic is precisely weighed and dissolved in 15 mL of hydrochloric acid, which is boiled for 5 minutes in a water bath. After cooling, the total volume of the solution is brought up to 250 mL with water. After adding phenolphthalein solution to 10 mL of the resulting solution, it is neutralized with ammonia solution. Diluted hydrochloric acid (1→2) is added until the precipitates dissolve. The total volume is brought up to 100 mL with water, which is heated to 70~80°C. 10 mL of 8-hydroxyquinoline solution and sufficient ammonium acetate solution are added

until yellow precipitates are formed, where additional 30 mL of ammonium acetate solution is added. The precipitates are again boiled for 30 minutes at 70°C in a water bath. It is then filtered through a glass filter that is previously weighed. The precipitates on the filter are washed hot water, then dried for 2 hours at 105°C, and weighed. 1 mg of precipitates corresponds to $\text{NaAl}_3\text{H}_{14}(\text{PO}_4)_8 \cdot 4\text{H}_2\text{O}$ 0.689 mg and $\text{Na}_3\text{Al}_2\text{H}_{15}(\text{PO}_4)_8$ 0.977 mg.

• 8-hydroxyquinoline solution : 5 g of 8-hydroxyquinoline is dissolved in ethyl alcohol (total volume 100 mL)

Sodium Aluminum Phosphate, Basic

Kasal

INS No.: 541(ii)

Synonyms: Kasal

CAS No.: 7785-88-8

Compositional Specifications of Basic Sodium Aluminum Phosphate

Content When Basic Sodium Aluminum Phosphate is converted into a heat treated form, it should contain within a range of 9.5 ~ 12.5% aluminum oxide (Al_2O_3).

Description Basic Sodium Aluminum Phosphate is scentless white powder.

Identification (1) Basic Sodium Aluminum Phosphate dissolves in hydrochloric acid.

(2) A solution of 1 g of Basic Sodium Aluminum Phosphate in 10 mL diluted hydrochloric acid (1→2) responds to test ofs of aluminum salt and phosphate in Identification.

Purity (1) Fluoride : 1 g of Basic Sodium Aluminum Phosphate is precisely weighed and is tested by purity (8) for 「Calcium Citrate」, its content should not be more than 30 ppm.

(2) Arsenic : It should be no more than 4.0 ppm tested by Arsenic Limit Test.

(3) Lead : Basic Sodium Aluminum Phosphate is precisely weighed and is tested by purity (2) for 「Sodium Metaphosphate」, its content should not be more than 4.0 ppm.

Loss on Ignition When thermogravimetric analysis is done at 700~800°C for 2 hours, weight loss should not be more than 9.0%.

Assay Approximately 2.5 g of Basic Sodium Aluminum Phosphate is precisely weighed and dissolved in 15 mL of hydrochloric acid, which is boiled for 5 minutes in a water bath. After cooling, the total volume of the solution is brought up to 250 mL with water. After adding phenolphthalein solution to 10 mL of the resulting solution, it is neutralized with ammonia solution. Diluted hydrochloric acid (1→2) is added until the precipitates dissolve. The total volume is brought up to 100 mL with water, which is heated to 70 ~ 80°C. 10 mL of 8-hydroxyquinoline solution and sufficient ammonium acetate solution are added until yellow precipitates are formed, where additional 30 mL of ammonium acetate solution is added. The precipitates are again boiled for 30 minutes at 70°C in a water bath. It is then filtered through a glass filter that is previously weighed. The precipitates on the filter are washed hot water, then dried for 2 hours at 105°C, and weighed. 1 mg of precipitates corresponds to aluminum oxide (Al_2O_3) 0.111 mg.

• 8-hydroxyquinoline solution : 5 g of 8-hydroxyquinoline is dissolved in ethyl alcohol to make 100 mL.

Sodium L-Ascorbate

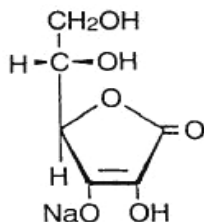

Chemical Formula: $C_6H_7NaO_6$

Molecular Weight: 198.11

INS No.: 301

Synonyms: L-Ascorbic acid monosodium salt

CAS No.: 134-03-2

Compositional Specifications of Sodium L-Ascorbate

Content Sodium L-Ascorbate when calculated on the dried basis, should contain not less than 99.0% of Sodium L-Ascorbate ($C_6H_7NaO_6$).

Description Sodium L-Ascorbate occurs as white to yellowish white crystalline powder, granules or fine granules. It is odorless and has a slightly salty taste.

Identification (1) 0.1 g of Sodium L-Ascorbate is dissolved in 100 mL of metaphosphoric acid solution (1→50) 100 mL. To 5 mL of this solution, iodine solution is drop-wise added until the solution turns pale yellow. 1 drop of cupric sulfate solution (1→1,000) and 1 drop of pyrol are added to the resulting solution, which is heated for 5 minutes 50~60°C. The solution becomes blue~bluish green.

(2) When 1~2 drops of sodium 2,6-dichloroindohanol solution (0.1→100) are added to 10 mL of aqueous solution of Sodium L-Ascorbate (1→100), blue color of the solution disappears.

(3) Sodium L-Ascorbate responds to the test for Sodium Salt in Identification.

Purity (1) Specific Rotation : Approximately 1 g of Sodium L-Ascorbate is accurately weighed, which is dissolved in freshly boiled and cooled water so that the total volume becomes 10 mL. Optical rotation of the solution is measured. When it is translated to dried material, it should be $[\alpha]_D^{25} = +103.0 \sim +108.0^\circ$.

(2) pH : When Sodium L-Ascorbate is proceeded as directed under glass electrode method, pH of an aqueous solution (1→50) should be within a range of 6.5~8.0.

(3) Arsenic : It should be no more than 4.0 ppm tested by Arsenic Limit Test.

(4) Lead : When 5.0 g of Sodium L-Ascorbate is tested by Atomic Absorption Spectrophotometry or Inductively Coupled Plasma Emission Spectroscopy, its content should not be more than 2.0 ppm.

(5) Mercury : When Sodium L-Ascorbate is tested by Mercury Limit Test, its content should not be more than 1.0 ppm.

Loss on Drying When Sodium L-Ascorbate is dried for 24 hours in a vacuum desiccator, the weight loss should not be more than 0.25%.

Assay Accurately weigh about 0.2 g of Sodium L-Ascorbate, accurately dried, dissolve in 50 mL of metaphosphoric acid solution (1→50), and titrate with 0.1 N iodine (indicator: starch solution).

0.1 N iodine 1 mL = 9.906 mg of $C_6H_7NaO_6$

Sodium Benzoate



Chemical Formula: $C_7H_5NaO_2$

Molecular Weight: 144.11

INS No.: 211

Synonyms: Sodium salt of benzenecarboxylic acid

CAS No.: 532-32-1

Compositional Specifications of Sodium Benzoate

Content Sodium Benzoate, when calculated on the dried basis, should contain not less than 99.0% of sodium benzoate ($C_7H_5NaO_2$).

Description Sodium Benzoate occurs as white crystalline powder or granules. It is odorless.

Identification Sodium Benzoate responds to Sodium Salt and Benzoate in Identification.

Purity (1) Clarity and Color of Solution : When 1 g of Sodium Benzoate is dissolved in 5 mL of water, the solution should be colorless and clear.

(2) Free Acid and Free Alkali : Weigh 2 g of Sodium Benzoate, dissolve it in 20 mL of boiling water, and add 2 drops of phenolphthalein solution and 0.2 mL of 0.1 N sulfuric acid. The solution is colorless. To this solution, add 0.4 mL of 0.1 N sodium hydroxide. The color of the solution should become red.

(3) Chlorinated Compounds : Weigh 0.5 g of Sodium Benzoate and 0.8 g of calcium carbonate which is transferred into a porcelain crucible, add 2.5 mL of diluted nitric acid, and mix thoroughly. Dry at 100°C, follow the procedure in Purity (2) for 「Benzoic Acid」. To prepare a reference solution, use 0.8 g of calcium carbonate and 22.5 mL of diluted nitric acid.

(4) Sulfate : Weigh 0.2 g of Sodium Benzoate, dissolve in water to make 100 mL, measure 40 mL of this solution, and add drop wise 2.5 mL of diluted hydrochloric acid while shaking well. Filter, wash with water, and combine the filtrate and the washings, Test Solution. When the test solution is tested by Sulfate Limit Test, the content should not be more than the amount corresponding to 0.5 mL of 0.01 N sulfuric acid.

(5) Phthalate : Proceed as directed under Purity (3) in 「Benzoic Acid」

(6) Arsenic : It should be no more than 4.0 ppm tested by Arsenic Limit Test.

(7) Lead : When 5.0 g of Sodium Benzoate is tested by Atomic Absorption Spectrophotometry or Inductively Coupled Plasma Emission Spectroscopy, its content should not be more than 2.0 ppm.

(8) Mercury : When Sodium Benzoate is tested by Mercury Limit Test, its content should not be more than 1.0 ppm.

(9) Readily Carbonizable Substances : When 0.5 g of Sodium Benzoate is tested for Readily Carbonizable Substances, its color should not be darker than the Color Standard Solution Q.

(10) Readily Oxidizable Substances : Add 1.5mL of sulfuric acid to 100 mL of water, heat to boiling and

add 0.1N potassium permanganate, dropwise, until the pink colour persists for 30 seconds. Dissolve 1 g of Sodium Benzoate, in the heated solution, and titrate with 0.1N potassium permanganate to a pink color that persists for 15 seconds at 70 °C. The content should not be more than 0.5 mL.

Loss on Drying When Sodium Benzoate is dried for 4 hours at 110°C, the weight loss should not be more than 1%.

Assay About 1.5 g of Sodium Benzoate, previously dried and accurately weighed, is transferred into a 300 mL flask with a ground-glass stopper, dissolve in 25 mL of water adding 75 mL of ether and 5 drops of methyl orange reagent, and titrate with 0.5 N hydrochloric acid. Perform the titration while mixing the water and ether layers well by shaking. At the end point, a light green color persists in the water layer.

1 mL of 0.5 N hydrochloric acid = 72.06 mg of $C_7H_5NaO_2$

Sodium Bicarbonate
Sodium Hydrogen Carbonate
Bicarbonate Soda

Chemical Formula: NaHCO_3

Molecular Weight: 84.01

INS No.: 500(ii)

Synonyms: Sodium hydrogen carbonate; Bicarbonate of soda; Sodium acid carbonate

CAS No.: 144-55-8

Compositional Specifications of Sodium Bicarbonate

Content Sodium Bicarbonate, when calculated on the dried basis, should contain not less than 99.0% of sodium bicarbonate (NaHCO_3).

Description Sodium Bicarbonate occurs as white crystalline powder or crystalline lumps.

Identification Sodium Bicarbonate responds to the tests for Sodium Salt and Bicarbonate in Identification.

Purity (1) Clarity and Color of Solution : When 1 g of Sodium Bicarbonate is dissolved in 20 mL of water, the solution should be clear.

(2) Carbonate : To 1 g of Sodium Bicarbonate, add carefully 20 mL of freshly boiled and cooled water, and dissolve while shaking horizontally at 15°C or below. Add 2.0 mL of 0.1 N hydrochloric acid, and add 2 drops of phenolphthalein solution. No pink color develops immediately.

(3) Ammonium Salt : When 1 g of Sodium Bicarbonate is heated, no odor of ammonia is evolved.

(4) Arsenic : It should be no more than 4.0 ppm tested by Arsenic Limit Test.

(5) Lead : Sodium Bicarbonate is tested by purity (2) for 「Sodium Metaphosphate」(not more than 2.0 ppm).

(6) Mercury : When Sodium Bicarbonate is tested by Mercury Limit Test, its content should not be more than 1.0 ppm.

(7) Chloride : Weigh 0.5 g of Sodium Bicarbonate, add 5 mL of diluted nitric acid, boil, cool and add 6 mL of diluted nitric acid, Test Solution. This Test Solution is tested by Chloride Limit Test and its content should not be more than the amount that corresponds to 0.3 mL of 0.01 N hydrochloric acid.

Loss on Drying When Sodium Bicarbonate is dried for 4 hours in a vacuum desiccator (silica gel), the loss should not be more than 0.25%.

Assay Accurately weigh about 3 g of Sodium Bicarbonate, previously dried, dissolve in 25 mL of water, and titrate with 1 N sulfuric acid (indicator : 3 drops of bromophenol blue solution). Near the end point, boil to expel carbon dioxide, cool, and continue the titration.

1 mL of 1 N sulfuric acid = 84.01 mg of NaHCO_3

Sodium Bisulfite

INS No.: 222

Synonyms: Sodium hydrogen sulfite

CAS No.: 7681-57-4

Definition Sodium Bisulfite is mixture of sodium bisulfite ($\text{NaHSO}_3 = 104.06$) and sodium pyrosulfite ($\text{Na}_2\text{S}_2\text{O}_5 = 190.11$).

Compositional Specifications of Sodium Bisulfite

Content Sodium Bisulfite should contain within a range of 58.5 ~ 67.4% as sulfur dioxide(SO_2).

Description Sodium Bisulfite is white powder. It has a odor of sulfur dioxide.

Identification Sodium Bisulfite responds to the test for Bisulfite Salts and Sodium Salts in Identification.

Purity (1) Clarity and Color of Solution : When 0.5 g of Sodium Bisulfite is dissolved in 10 mL of water, the turbidity of the solution should be very low or less.

(2) Arsenic : It should be no more than 4.0 ppm tested by Arsenic Limit Test.

(3) Lead : Sodium Bisulfite is tested by purity (2) for 「Sodium Metaphosphate」(not more than 2.0 ppm).

(4) Selenium : 2.0 g of Sodium Bisulfite, accurately weighed, transfer into a 50 mL beaker, add 10 mL of water and 5 mL of hydrochloric acid and boil to remove sulfur dioxide, Test Solution. Separately, transfer 1.0 g of Sodium Bisulfite and 0.05 mL of selenium standard solution into a beaker, and proceed in the same manner as for test solution, Reference solution. 2 g of hydrazin sulfate is added into each beaker, heated and dissolved. After setting for 5 minutes, the resulting solution is transferred into a Nestler cylinder with adding water to make 50 mL. The red color of this test solution should not be deeper than that of reference solution (Not more than 5 ppm).

(5) Iron : When the test solution in (3) Purity is tested by Atomic Absorption Spectrophotometry or Inductively Coupled Plasma Emission Spectroscopy, its content should not be more than 10 ppm.

(6) Mercury : When Sodium Bisulfite is tested by Mercury Limit Test, its content should not be more than 1.0 ppm.

Assay Dissolve 0.2 g of Sodium Bisulfite, accurately weighed, in 50 mL of 0.1 N iodine solution into an Erlenmeyer flask with a stopper. Proceed as directed under Assay in 「Sodium Sulfite」.

1 mL of 0.1 N iodine solution = 3.203 mg SO_2

Sodium Carbonate

Crystal : Carbonate Soda

Anhydrous : Soda Ash

Chemical Formula: $\text{Na}_2\text{CO}_3 \cdot n\text{H}_2\text{O}$ (n = 10, 1 or 0)

Molecular Weight: 10hydrates 286.14

1 hydrate 124.00

anhydrous 105.99

INS No.: 500(i)

CAS No.: 497-19-8

5968-11-6

Synonyms: Soda ash; Sodium salt of carbonic acid

$\text{Na}_2\text{CO}_3 \cdot n\text{H}_2\text{O}$ (n=0, 1 or 10)

Molecular Weight decahydrate 286.14

hydrate 124.00

Anhydrous 105.99

Definition Sodium Carbonate occurs as crystals (hydrate, decahydrate), and anhydrous called Sodium Carbonate (crystal) or as Anhydrous called Sodium Carbonate (Anhydrous).

Compositional Specifications of Sodium Carbonate

Content

Sodium Carbonate, when calculated on the dried basis, should be contain not less than 99.0% of sodium carbonate ($\text{Na}_2\text{CO}_3 = 105.99$).

Description Sodium Carbonate (crystal) occurs as a white crystalline power or as colorless to white crystalline lumps. Sodium Carbonate (Anhydrous) occurs as white powder or granules.

Identification Sodium Carbonate responds to the tests for Sodium Salt and Carbonate in Identification.

Purity Dry Sodium Carbonate at 70°C, gradually raise the temperature to 250 ~ 300°C, and dry it until the weight becomes constant. Then test Sodium Carbonate.

- (1) Clarity and Color of Solution : 1 g of Sodium Carbonate is dissolved in 20 mL of water This is very slightly turbid.
- (2) Arsenic : It should be no more than 4.0 ppm tested by Arsenic Limit Test.
- (3) Lead : Sodium Carbonate is tested by purity (2) for 「Sodium Metaphosphate」(not more than 2 ppm).
- (4) Mercury : When Sodium Carbonate is tested by Mercury Limit Test, its content should not be more than 1.0 ppm.
- (5) Chloride : To 0.5 g of Sodium Carbonate, 6 mL of diluted nitric acid is added. It is then boiled and cooled, where water is added to bring the total volume to 100 mL. 10 mL of the resulting solution is mixed with 6 mL of nitric acid, Test Solution. When the test solution is tested by Chloride Limit Test, its content should not be more than the amount that corresponds to 0.5 mL of 0.01 N hydrochloric acid.

Loss on Drying Dry Sodium Carbonate at 70°C, gradually raise the temperature to 250 ~ 300°C, and dry it until the weight becomes constant. The loss on drying should be 2.0% or less, 15% or less, and 55~65% for anhydrous, monohydrate and decahydrate form, respectively.

Assay Accurately weigh about 0.6 g of Sodium Carbonate, previously dried, dissolve in 50 mL of water, and titrate with 0.5 N hydrochloric acid (indicator : 3 drops of bromophenol blue solution). Near the end point, boil to expel carbon dioxide, cool, and continue the titration.

1 mL of 0.5 N hydrochloric acid = 26.497 mg of Na_2CO_3

Sodium Carboxymethyl Starch

Compositional Specifications of Sodium Carboxymethyl Starch

Description Sodium Carboxymethyl Starch occurs as a white powder. It is odorless.

Identification (1) To 5 mL of Sodium Carboxymethyl Starch solution (1→1,000), add 5 drops of diluted hydrochloric acid (1→3) and 1 drop of iodine solution, and shake. The color of the solution changes to a blue to red-purple color.

(2) To 1 mL of Sodium Carboxymethyl Starch solution (1→500), add 5 mL of chromotropic acid solution, and heat in a water bath for 10 minutes. The color of the solution changes to a purple to purple-pink color.

(3) To 5 mL of Sodium Carboxymethyl Starch solution (1→500), add 1 mL of cupric sulfate solution (1→20), and shake. A light blue precipitate is formed.

(4) Ignite 1 g of Sodium Carboxymethyl Starch. The residue responds to the test for Sodium Salt in Identification.

Purity (1) pH : Sodium Carboxymethyl Starch solution(1→50) as test solution, is proceeded as directed under pH Determination. It should be within a range of 6.0 ~ 8.5.

(2) Chloride : To 0.1 g of Sodium Carboxymethyl Starch, add 10 mL of water and 1 mL of nitric acid, heat in a water bath for 10 minutes, cool, and filter if necessary. Wash the residue with a small amount of water, combine the filtrate and the washings, and add water to make 100 mL. Take 25 mL of this solution and 6 mL of diluted nitric acid is added, test solution. When Sodium Carboxymethyl Starch is tested by Chloride Limit Test, its content should not be more than the amount that corresponds to 0.3 mL of 0.01 N hydrochloric acid.

(3) Sulfate : To 0.1 g of Sodium Carboxymethyl Starch, add 10 mL of water and 1 mL of hydrochloric acid, heat in a water bath for 10 minutes, cool, and filter if necessary. Wash the residue with a small amount of water, combine the filtrate and the washings, and add water to make 50 mL. Measure exactly 10 mL of this solution and 1 mL of diluted nitric acid is added, test solution. When Sodium Carboxymethyl Starch is tested by Sulfate Limit Test, its content should not be more than the amount that corresponds to 0.4 mL of 0.01 N sulfuric acid.

(4) Arsenic : It should be no more than 4.0 ppm tested by Arsenic Limit Test.

(5) Lead : Sodium Carboxymethyl Starch is tested by Purity (2) for Sodium Metaphosphate (not more than 2 ppm).

Loss on Drying When Sodium Carboxymethyl Starch is dried for 4 hours at 105°C, the loss should not be more than 10%.

Sodium Carboxymethylcellulose

Cellulose Gum
Carboxymethylcellulose
CMC
Sodium CMC

INS No.: 466

Synonyms: Cellulose gum; Carboxymethyl cellulose;
CMC; Sodium CMC

CAS No.: 9004-32-4

Compositional Specifications of Sodium Carboxymethylcellulose

Description Sodium Carboxymethylcellulose occurs as a white to light yellow powder, or granular or fibrous substance. It is odorless.

Identification (1) To 100 mL of water, add 1 g of Sodium Carboxymethylcellulose in small portions while stirring and allow to stand until it becomes a uniformly pasty solution.

- ① Test solution is diluted by a factor of 5 with water. 1 drop of the resulting solution is mixed with 0.5 mL of chromotropic acid solution, which is then heated for 10 minutes in a water bath. A pink-purple color develops.
- ② To 5 mL of the test solution, add 10 mL of acetone, and shake well. A white flocculent precipitate is formed.
- ③ To 5 mL of the test solution, add 5 mL of cupric sulfate solution (1→20) and shake. A pale blue flocculent precipitate is formed.

(2) Ignite 1 g of Sodium Carboxymethylcellulose at 550 ~ 600°C for 3 hours. The residue responds to the test for Sodium Salt in Identification.

Purity (1) pH : To 0.5 g of Sodium Carboxymethylcellulose, add small portion in 50 mL of water while stirring. Occasionally stir and heat it for 20 minutes at 60~70°C. Cool it down and use the supernatant as test solution. Test for pH and pH should be within a range of 6.0 ~ 8.5.

(2) Chloride : Weigh 0.1 g of Sodium Carboxymethylcellulose, add 20 mL of water and 0.5 mL of hydrogen peroxide, and heat in a water bath 30 minutes. Cool. add water to make 100 mL, and filter through a dry filter paper. measure exactly 25 mL of the filtrate as the test solution. Test by Chloride Limit Test, content should not be more than the amount that corresponds to 0.45 mL of 0.01 N sulfuric acid.

(3) Sulfate : 20 mL of the filtrate obtained in Purity (2) is tested by Sulfate Limit Test. Test by Sulfate Limit Test content should not be more than amount that correspond to 0.4 mL of 0.01 N sulfuric acid.

(4) Arsenic : It should be no more than 4.0 ppm tested by Arsenic Limit Test.

(5) Lead : When 5.0 g of Sodium Carboxymethylcellulose is tested by Atomic Absorption Spectrophotometry or Inductively Coupled Plasma Emission Spectroscopy, its content should not be

more than 2.0 ppm.

(6) Cadmium : When 5.0 g of Sodium Carboxymethylcellulose is tested by Atomic Absorption Spectrophotometry or Inductively Coupled Plasma Emission Spectroscopy, its content should not be more than 1.0 ppm.

(7) Mercury : When Sodium Carboxymethylcellulose is tested by Mercury Limit Test, its content should not be more than 1.0 ppm.

Loss on Drying When Sodium Carboxymethylcellulose is dried for 4 hours at 105°C, the weight loss should not be more than 12%.

Sodium Caseinate

Synonyms: Casein-sodium

CAS No.: 9005-46-3

Compositional Specifications of Sodium Caseinate

Content Sodium Caseinate, when calculated on the dried basis, should contain within a range of 14.5 ~ 15.8% of nitrogen (N = 14.01).

Description Sodium Caseinate occurs as white to pale yellow powder, granules, or flakes. It is odorless and tasteless or has a slight, characteristic odor and taste.

Identification (1) Proceed as directed under Identification (1), (2), and (3) in 「Casein」.

(2) The residue on ignition of Sodium Caseinate responds to the test for Sodium Salt in Identification.

Purity (1) Clarity and Color of Solution : Proceed as directed under Purity (1) in 「Casein」.

(2) pH : Sodium Caseinate solution(1→50) should be within a range of pH 6.0 ~ 7.5

(3) Fat : Proceed as directed under Purity (4) in 「Casein」.

(4) Arsenic : It should be no more than 2.0 ppm tested by Arsenic Limit Test.

(5) Lead : When 5.0 g of Sodium Caseinate is tested by Atomic Absorption Spectrophotometry or Inductively Coupled Plasma Emission Spectroscopy, its content should not be more than 2.0 ppm.

Loss on Drying When Sodium Caseinate is dried for 3 hours at 100°C, the weight loss should not be more than 15%.

Residue on Ignition When thermogravimetric analysis is done with approximately 1 g of dried Sodium Caseinate, the amount of residues should not be more than 6%.

Assay Accurately weigh about 0.15 g of Sodium Caseinate, previously dried, and proceed as directed under Kjeldahl Method in Nitrogen Determination.

1 mL of 0.1 N sulfuric acid = 1.401 mg of N

Potassium Caseinate

Synonyms: Casein-potassium

CAS No.: 68131-54-4

Compositional Specifications of Potassium Caseinate

Content Potassium Caseinate, when calculated on the dried basis, should contain within a range of 13.9 ~ 15.8% of nitrogen (N = 14.01).

Description Potassium Caseinate occurs as white to pale yellow powder, granules, or flakes. It is odorless and tasteless or has a slight, characteristic odor and taste.

Identification (1) Proceed as directed under Identification (1), (2), and (3) in 「Casein」.

(2) The residue on ignition of Potassium Caseinate responds to the test for Potassium Salt in Identification.

Purity (1) Clarity and Color of Solution : Proceed as directed under Purity (1) in 「Casein」. The resulting solution should be colorless and should not be more than turbid.

(2) pH : Potassium Caseinate solution(1→50) should be within a range of pH 6.0 ~ 7.5

(3) Fat : Proceed as directed under Purity (4) in 「Casein」. The amount should not be more than 1.5 %.

(4) Arsenic : It should be no more than 2.0 ppm according to the Arsenic Limit Test.

(5) Lead : When 5.0 g of Sodium Caseinate is tested by Atomic Absorption Spectrophotometry or Inductively Coupled Plasma Emission Spectroscopy, it should not be more than 1.0 ppm.

(6) Lactose: Put 1 g of this food additive in a 150 mL beaker and add 25mL of water. Dissolve it at 60 to 70°C and cool it down to room temperature. Add 15 mL of water, 8 mL of 0.1N hydrochloric acid and 1 mL of 10% acetic acid, and shake for mixing. After 5 minutes, add 1 mL of 1M sodium acetic acid and mix them well. When the sediment subsides, filter it out of the first 5mL of the filtrate, take 2 mL of the remaining filtrate, transfer it to the test tube. Then add 0.2 mL of the phenol solution, mix it well, and add 5 mL of sulfuric acid to mix it within 1 to 2 seconds. After checking that the solution is well blended, let it stand for 15 minutes and then cool it down in a bath of 20°C for 5 minutes, and use it as test solution. Pour 1, 2, 3 and 4 mL of a lactose stock solution(2 mg/mL) into each 500mL mass flask, and add water to 500mL to make lactose concentration of 20, 40, 60, and 80µg/mL. Add 2 mL of water to the five test tubes first, then add 3 mL of a standard solution, 0.2mL of a phenol solution and mix. Then add 5 mL of sulfuric acid and mix them within 1 to 2 seconds. After verifying that the solution is completely mixed, let it stand for 15 minutes and then cool it down in a bath of 20°C for 5 minutes. And use it as a standard solution. Prepare a calibration curve by measuring the absorbency of the standard solution at 1cm liquid layer and 490nm wavelength with water as a control solution. Measure absorbance A of the test solution and the content of the calculatino should not be more than 2.0 % according to the following formula.

$$\text{The lactose content(\%)} = \frac{A \times 0.00475}{\text{}}$$

$$a \times m$$

A = Absorption of the test solution

a = Absorption factor of the standard lactose solution (slope of the calibration curve)

m = weight of sample(g)

Phenol solution: Heat mixture of 8 g of phenol and 2 g of water to dissolve until crystals are removed.

Loss on Drying When Potassium Caseinate is dried for 3 hours at 100°C, the weight loss should not be more than 15.0%.

Assay Accurately weigh about 0.15 g of Potassium Caseinate, previously dried, and proceed as directed under Kjeldahl Method in Nitrogen Determination.

1 mL of 0.1 N sulfuric acid = 1.401 mg of N

Sodium Copper Chlorophyllin

Synonyms: Sodium chlorophyllin

INS No.: 141(ii)

Compositional Specifications of Sodium Copper Chlorophyllin

Description Sodium Copper Chlorophyllin occurs as a blue-black to green-black powder. It is odorless or has a slight, characteristic odor.

Identification (1) Residues on ignition of Sodium Copper Chlorophyllin is dissolved in 10 mL of dilute hydrochloric acid by heating in a water bath. If the solution is not clear, it is filtered. Add water to make 10 mL, Test Solution. Following tests are carried out with this Test Solution.

(A) The test solution is tested by Perform Flame Coloration Test. The color of the flame is first green and then changes to yellow.

(B) To 5 mL of the test solution, add 0.5 mL of sodium diethyldithiocarbamate solution (1→1,000), a brown precipitate is formed.

(2) To 1 mL of Sodium Copper Chlorophyllin solution (1→1,000), add phosphate buffer solution (pH 7.5) to make 100 mL, and measure the absorbance. The solution exhibits maximum absorption bands at wavelengths of 403 ~ 407 nm and 627 ~ 633 nm. When the absorbances at these absorption maxima are A_1 and A_2 , the absorbance ratio A_1/A_2 is should not be more than 4.0.

Purity (1) pH : pH of this solution of Sodium Copper Chlorophyllin (1→100) should be within a range 9.5 ~ 11.0

(2) Specific Absorbance : Dissolve 0.1 g of Sodium Copper Chlorophyllin, accurately weighed, in water to make 1,000 mL. Take 10 mL of this solution, add phosphate buffer solution (pH 7.5) to make 100 mL. When the absorbance at the maximum absorption band near 405 nm and its value is converted into that of a dried form, $E_{1cm}^{1\%} = 508$ or higher. In this case, a light-shielded container should be used to avoid direct light.

(3) Arsenic : It should be no more than 4.0 ppm tested by Arsenic Limit Test.

(4) Lead : When 5.0 g of Sodium Copper Chlorophyllin is tested by Atomic Absorption Spectrophotometry or Inductively Coupled Plasma Emission Spectroscopy, its content should not be more than 5.0 ppm.

(5) Cadmium : When 5.0 g of Sodium Copper Chlorophyllin is tested by Atomic Absorption Spectrophotometry or Inductively Coupled Plasma Emission Spectroscopy, its content should not be more than 1.0 ppm.

(6) Mercury : When Sodium Copper Chlorophyllin is tested by Mercury Limit Test, its content should not be more than 1.0 ppm.

(7) Residue Solvent : When Sodium Copper Chlorophyllin is tested by Purity (5) for 「Oleoresin

Paprika₁,

Acetone] not more than 50 ppm(separate or total in case of use in combination)
Methyl Alcohol	
Isopropyl Alcohol	
Hexane	

Methylene Chloride should not be more than 10 ppm

(8) Inorganic Copper Salt : 1 g of Sodium Copper Chlorophyllin is dissolved in 60 mL of water. 1 µl of this solution is tested by Thin-Layer Chromatography without using a reference solution. Mixture of n-butanol:water:acetic acid (4:2:1) is used as a developing solvent. No light brown spots should be observed. For the thin-layer plate, silica gel for thin-layer chromatography is dried at 110°C for 1 hour. The development is stopped when the solvent front reaches approximately 10 cm. It is then air dried and sodium diethyldithiocarbamate solution (1→1,000) is sprayed upon the plate (not more than 300µg/g as Cu).

Loss on Drying When Sodium Copper Chlorophyllin is dried for 2 hours at 105°C, the weight loss should not be more than 5%.

Sodium Dehydroacetate



Chemical Formula: $C_8H_7O_4Na \cdot H_2O$

Molecular Weight: 208.15

INS No.: 266

Synonyms: Sodium 3-(1-hydroxyethylidene)- 6-methyl-1,2-pyran-2,4(3H)-dione

CAS No.: 4418-26-2

Compositional Specifications of Sodium Dehydroacetate

Content Sodium Dehydroacetate, when calculated on the dried basis, should contain not less than 98.0% of sodium dehydroacetate ($C_8H_7O_4Na \cdot H_2O = 190.13$).

Description Sodium Dehydroacetate occurs as a white crystalline powder. It is odorless or has a slight odor.

Identification (1) To 2 mL of an solution of Sodium Dehydroacetate (1→100), add 3 drops of potassium sodium tartarate solution and 2 drops of strong cupric acetate solution, and shake, a purple precipitate with white tint is produced.

(2) To 0.1 g of Dehydroacetic Acid, add 1 mL of water and 3 ~ 5 drops of salicylaldehyde solution and 0.1 mL of sodium hydroxide solution (1→2), and heat in water bath, it turns red.

(3) Sodium Dehydroacetate responds to the test for Sodium Salt in Identification.

(4) Dissolve 0.5 g of Sodium Dehydroacetate in 100 mL of water, add 1 mL of diluted hydrochloric acid, filter the resulting precipitate, and wash thoroughly with water. After drying at 75~80°C for 4 hours, the melting point should be within a range of 109 ~ 112°C.

Purity (1) Clarity and Color of Solution : Dissolve 0.5 g of Sodium Dehydroacetate in 10 mL of water, it should be colorless.

(2) Free Alkali : Dissolve 1 g of Sodium Dehydroacetate in 20 mL of freshly boiled and cooled water, add 2 drops of phenolphthalein solution. Even if a pink color develops, it should disappear upon addition of 0.3 mL of 0.1 N sulfuric acid.

(3) Chloride : Dissolve 1 g of Sodium Dehydroacetate in 30 mL of water, and shaking and add 9.5 mL of dilute nitric acid, and filtering. The residue is washed with water and the wash water is added to the filtrate. The filtrate is tested by Chloride Limit Test, its content should not be more than the amount that corresponds to 0.3 mL of 0.01 N hydrochloric acid.

(4) Sulfate : Dissolve 1 g of Sodium Dehydroacetate in 30 mL of water, and shaking, add 3 mL of dilute hydrochloric acid and filter. The residue is washed with water and the wash water is added to the filtrate. The filtrate is tested by Sulfate Limit Test, its content should not be more than the amount that corresponds to 0.3 mL of 0.01 N sulfuric acid.

(5) Arsenic : It should be no more than 4.0 ppm tested by Arsenic Limit Test.

(6) Lead : When 5.0 g of Nicotinic Acid is tested by Atomic Absorption Spectrophotometry or Inductively Coupled Plasma Emission Spectroscopy, its content should not be more than 2.0 ppm.

(7) Readily Carbonizable Substances : To 0.3 g of Sodium Dehydroacetate, test by Readily carbonizable substances. Its color should not be deeper than that of a Color Standard Solution C.

Water Content Accurately weigh 0.3 g of Sodium Dehydroacetate and test by the back titration method in Water Content Determination (Karl-Fischer Method). The water content should be within a range of 8.3 ~ 10.0%.

Residues on Ignition When thermogravimetric analysis is done with 1 g of Sodium Dehydroacetate, the residue should be within a range of 33.3 ~ 34.6%.

Assay Accurately weigh about 0.4 g of Sodium Dehydroacetate, add 50 mL of glacial acetic acid (for nonaqueous titration), and titrate with 0.1 N perchloric acid (indicator: 10 drops of α -naphtholbenzein solution) The end point is until the brown color of the solution changes to green.

1 mL of 0.1 N perchloric acid = 19.01 mg of $C_8H_7O_4Na$

Sodium Diacetate

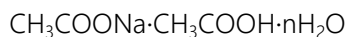

Chemical Formula: $\text{C}_4\text{H}_7\text{NaO}_4\cdot n\text{H}_2\text{O}$

Molecular Weight: anhydrous 142.09

INS No.: 262(ii)

Synonyms: Sodium hydrogen diacetate

CAS No.: 126-96-5

Compositional Specifications of Sodium Diacetate

Content Sodium Diacetate, when calculated on the dried basis(anhydrous), should contain 39.0~41.0% of free acetic acid and 58.0~60.0% of sodium acetate.

Description Sodium Diacetate is white hygroscopic crystalline solid with a scent of acetic acid.

Identification Sodium Diacetate solution (1→10) responds to test of acetates and sodium salts in Identification.

Purity (1) Lead : When 5.0 g of Sodium Diacetate is tested by Atomic Absorption Spectrophotometry or Inductively Coupled Plasma Emission Spectroscopy, its content should not be more than 2.0 ppm.

(2) Arsenic : It should be no more than 4.0 ppm tested by Arsenic Limit Test.

(3) Mercury : When Sodium Diacetate is tested by Mercury Limit Test, its content should not be more than 1.0 ppm.

(4) Readily Oxidizable Matters (as formic acid) : 1 g of Sodium Diacetate is dissolved in 50 mL of water. After adding 10 mL of dilute sulfuric acid, it is then heated at 80~90°C. This hot solution is titrated with 0.1 N potassium permanganate solution until the pale red color persists for at least 15 seconds. The content of readily oxidizables should not be more than 0.2%.

$$1 \text{ mL of } 0.1 \text{ N potassium permanganate solution} = 2.301 \text{ mg CH}_2\text{O}_2$$

Water Content Water content of Sodium Diacetate is determined by water determination (Karl-Fisher Method) and should not be more than 2.0%.

Assay (1) Free Acetic Acid : Approximately 4 g of Sodium Diacetate is precisely weighed and dissolved in 50 mL of water. After adding phenolphthalein solution, it is titrated with 1 N sodium hydroxide solution.

$$1 \text{ mL of } 1 \text{ N sodium hydroxide solution} = 60.05 \text{ mg CH}_3\text{COOH}$$

(2) Sodium Acetate : Approximately 0.5 g is precisely weighed and dissolved in 50 mL of glacial acetic

acid. This solution is titrated with 0.1 N perchloric acid solution (indicator : 1 mL of crystal violet solution in glacial acetic acid). At the end point, the solution turns from violet to blue, then to green. Separately, perform a blank test in the same manner.

1 mL of 0.1 N perchloric acid = 8.203 mg CH_3COONa

Sodium Erythorbate

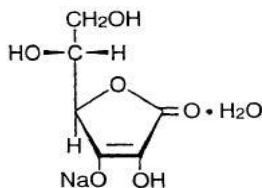

Chemical Formula: $C_6H_7O_6Na \cdot H_2O$

Molecular Weight: 216.13

INS No.: 316

Synonyms: Sodium isoascorbate

CAS No.: 6381-77-7

Compositional Specifications of Sodium Erythorbate

Content Sodium Erythorbate, when calculated on the dried basis, should contain not less than 98.0% of sodium erythorbate ($C_6H_7O_6Na \cdot H_2O$).

Description Sodium Erythorbate occurs as white to yellowish white crystalline powder, or granules. It is odorless and has a slightly salty taste.

Identification (1) Dissolve 0.1 g of Sodium Erythorbate in 100 mL of metaphosphoric acid solution (1→50). To 5 mL of this solution, add drop wise iodine solution until a slightly yellow color develops. To this solution, add 1 drop of cupric sulfate solution (1→1,000) and 1 drop of pyrrole, and warm in a water bath at 50 ~ 60°C for 5 minutes. A blue to blue-green color develops.

(2) To 10 mL of Sodium Erythorbate (1→100), add 1 mL of potassium permanganate solution. A pink color develops, and this color disappears immediately.

(3) Sodium Erythorbate responds to the test for Sodium Salt in Identification.

Purity

- (1) Specific Rotation : Approximately 1 g of Sodium Erythorbate is precisely weighed, which is dissolved in freshly boiled and cooled water so that the total volume becomes 10 mL. Optical rotation of this solution should be within a range of $[\alpha]_D^{25} = +95.5 \sim +98.0^\circ$
- (2) Clarity and Color of Solution : Weigh 1 g of Sodium Erythorbate, and dissolve it in 10 mL of water. This solution is clear, and its color is not darker than that of color standard solution J.
- (3) pH : pH of Sodium Erythorbate solution (1→20) should be within a range of 5.5 ~ 8.0.
- (4) Arsenic : It should be no more than 4.0 ppm tested by Arsenic Limit Test.
- (5) Lead : When 5.0 g of Sodium Erythorbate is tested by Atomic Absorption Spectrophotometry or Inductively Coupled Plasma Emission Spectroscopy, its content should not be more than 2.0 ppm.
- (6) Mercury : When Sodium Erythorbate is tested by Mercury Limit Test, its content should not be more than 1.0 ppm.

Loss on Drying Sodium Erythorbate is dried for 24 hours in a vacuum desiccator (silica gel) and the weight loss should not be more than 0.3%.

Assay Accurately weigh about 1 g of Sodium Erythorbate, previously dried, and dissolve it in metaphosphoric acid solution (1→50) to make exactly 250 mL. Measure exactly 50 mL of this solution, and titrate with 0.1 N iodine (indicator : starch solution).

1 mL of 0.1 N iodine = 10.81 mg of $C_6H_7O_6Na.H_2O$

Sodium Ferric Pyrophosphate

Sodium Iron Pyrophosphate

Chemical Formula: $\text{Na}_8\text{Fe}_4(\text{P}_2\text{O}_7)_5 \cdot n\text{H}_2\text{O}$

Molecular Weight: 1277.02(as anhydrous)

Synonyms: Sodium iron pyrophosphate

CAS No.: 10045-87-1

Compositional Specifications of Sodium Ferric Pyrophosphate

Content Sodium Ferric Pyrophosphate should contain within a range of 14.5 ~ 16.0% of iron (Fe).

Description Sodium Ferric Pyrophosphate is scentless white ~ yellowish brown powder.

Identification 0.5 g of Sodium Ferric Pyrophosphate is dissolved in 5 mL of dilute hydrochloric acid (1→2). When excess sodium hydroxide solution is added, reddish brown precipitates are formed. This is stirred for several minutes and filtered. The small amount of the initial filtrate is discarded. 1 drop of bromophenol blue solutions added to 5 mL of the clear filtrate. When 1 N hydrochloric acid is added drop-wise, the filtrated turns green, where 10 mL of zinc sulfate solution (1→8) is added. Upon adjusting pH to 3.8, white precipitates are formed.

Purity (1) Fluoride : 1 g of Sodium Ferric Pyrophosphate is precisely weighed and tested by Purity (3) for [Calcium Oxide]. The total consumed amount of sodium fluoride should not exceed 2.5 mL (Not more than 0.005%).

(2) Lead : 1.0 g of Sodium Ferric Pyrophosphate is weighed and transferred into 50 mL flask. Add 10 mL of 9 N hydrochloric acid, 10 mL of water, 20 mL of ascorbic acid-sodium iodide solution and 5 mL of trioctyl phosphine oxide solution and shake it to mix for 30 seconds. Add keep it to separate the layer and again add water so that organic layer reaches to neck part of flask. After shaking to mix it, keep it to separate the layer. This organic solvent layer is used as test solution. Separately, take 10 mL of lead standard solution and make it precisely to 100 mL. Take 2 mL of this solution and transfer into 50 mL flask. And operate under condition as test solution method, this solution is used as reference solution. When it is tested by Atomic Absorption Spectrophotometry or Inductively Coupled Plasma Emission Spectroscopy, absorbance(luminous intensity) of test solution should not be more than absorbance(luminous intensity) of reference solution.(not be more than 2.0 ppm.)

Ascorbic acid-sodium iodide solution : 10 g of ascorbic acid and 19.3 g sodium iodide are dissolved in water to make to 100 mL.

Trioctyl phosphine oxide solution : 5 g of trioctyl phosphine oxide is dissolved in methyl isobutyl ketone to make to 100 mL.

(3) Mercury : Proceed as directed under Purity (4) for [Reduced Iron]. However, the same procedure is followed with 3 mL of mercury standard solution (for reduced solution) (Not more than 3 ppm).

Loss on Ignition When thermogravimetric analysis is done at 800°C for 1 hour, loss weight should not be more than 8.0%.

Assay Proceed as directed under Assay of [Ferric Pyrophosphate].

Sodium Ferrocyanide

Chemical Formula: $\text{Na}_4\text{Fe}(\text{CN})_6 \cdot 10\text{H}_2\text{O}$

Molecular Weight: 484.06

INS No.: 535

Synonyms: Hexacyanoferrate of sodium; Yellow prussiate of soda

CAS No.: 13601-19-9

Compositional Specifications of Sodium Ferrocyanide

Content When Sodium ferrocyanide is quantified, it should contain not less than 99.0% of sodium ferrocyanide ($\text{Na}_4\text{Fe}(\text{CN})_6 \cdot 10\text{H}_2\text{O}$).

Description Sodium ferrocyanide is a yellow crystal or crystalline powder.

Identification (1) When 1 mL of ferric chloride is added to 10 mL of sodium ferrocyanide (1→100), a dark blue precipitate are formed.

(2) Sodium ferrocyanide responds to test of sodium salt in the identification method.

Purity (1) Cyanide : 10 mg of copper sulfate is dissolved in 8 mL of water and 2 mL of ammonium solution. A filtering paper is dipped into this solution, to which hydrogen sulfide is then added. When 1 drop of the aqueous solution of this additive (1→100) is dropped on the filtering paper that turned brown, white rings should not appear.

(2) Ferrocyanide : 10 mg of sodium ferrocyanide is dissolved in 10 mL of water. When a few drops of 2 N acetic acid that is saturated with benzidine and 1 drop of 1% lead nitrate are added to 1 drop of this solution, blue precipitates or color should not formed.

(3) Lead : Accurately weigh 5.0 g of sodium ferrocyanide into a 150 mL beaker, add 30 mL of water. Add Hydrochloric acid in small portion to the solution until the solid is dissolved throughly and add 1 mL of hydrochloric acid. Heat this solution for approximately 5 minutes and cool down. Add water to bring the total volume to 100 mL. Add Sodium Hydroxide Solution(1→4) or Hydrochloric acid(1→4) so that pH becomes 2 ~ 4. Transfer this solution into 250 mL separatory funnel, where water is added to make 200 mL. Then add 2 mL of 2% APDC solution and shake to mix. Extract the solution 2 times with 20 mL each of chloroform, which is evaporated to dryness in a water bath. Add 3 mL of Nitric Acid to the residue and heat it until nearly evaporated. To this solution, add 0.5 mL of Nitric Acid and 10 mL of water, concentrate it until the final solution becomes 3~5 mL, and add water to make 10 mL, test solution. When the test solution is tested by Atomic Absorption Spectrophotometry or Inductively Coupled Plasma Emission Spectroscopy, its content should not be more than 5.0 ppm.

2% APDC Solution : 2.0 g of Ammonium Pyrolidine Dithiocarbamate is dissolved in water to make 100 mL. Filter it when using.

(4) Chloride : When 0.11 g of sodium ferrocyanide is tested by Chloride Limit Test, the detected amount should not be more than the amount that corresponds to 0.6 mL of 0.01 N hydrochloric acid.(not

more than 0.2%)

- (3) (5) Sulfate : When 0.2 g of sodium ferrocyanide is tested by Sulfate Limit Test, the detected amount should not be more than the amount that corresponds to 0.4 mL of 0.01 N hydrochloric acid. (not more than 0.1%)

Water Content Water content of sodium ferrocyanide is determined by water determination (Karl-Fisher Titration) and should not be more than 1.0%.

Assay About 1.0 mg of sodium ferrocyanide is weighed accurately, dissolved in 200 mL of water, and 10 mL of sulfuric acid is added. Then the solution is titrated with 0.02 N potassium permanganate until the red color lasts for 30 secs.

1 mL of 0.02 N potassium permanganate = 48.41 mg of $\text{Na}_4\text{Fe}(\text{CN})_6 \cdot 10\text{H}_2\text{O}$

Sodium ferrous citrate

Chemical Formula: $\text{Na}_4\text{FeC}_{12}\text{H}_{10}\text{O}_{14}$

Molecular Weight: 526.01

Synonyms: Iron(II) sodium salt of 2-hydroxypropane-1,2,3-tricarboxylic acid

Compositional Specifications of Sodium ferrous citrate

Content Sodium ferrous citrate should contain 10.0-11.0% of Ferrous(Fe=55.85).

Description Sodium ferrous citrate occurs as light green to greenish yellow powder. It is odorless.

Identification (1) To 5 mL of Sodium ferrous citrate solution(1→100), add 1mL of hydrochloric acid(1→4) and 0.5mL of freshly prepared potassium ferrocyanide solution(1→10). A blue color appears.

(2) To 5mL of Sodium ferrous citrate solution(1→100), add 2mL of ammonia water. A red-brown color develops, but precipitate is not formed.

(3) Ignite 3g of Sodium ferrous citrate at 500-600°C for 3 hours. The residue responds to the test for sodium salts in Identification.

(4) To 0.5g of Sodium ferrous citrate, add 5mL of water and 10mL of potassium hydroxide solution(1→25), heat in a water bath for 10 minutes while stirring well, cool and filter. Take a portion of the filtrate, neutralize with acetic acid(1→2), then add an excess of calcium chloride dihydrate solution(3→40) and boil. A white precipitate is formed. After collecting the precipitate, add sodium hydroxide solution(1→25) to a part of it. The precipitate does not dissolve. Add hydrochloric acid(1→4) to the other part of the precipitate, then it dissolves.

Purity (1) Sulfate : Weigh 0.4g of Sodium ferrous citrate, add 50mL of water and dissolve it. Then add 100mL of water again. Take 10mL of this solution, then add 1mL of hydrochloric acid(1→4) and 0.1g of hydroxylamine chloride. boil for 1 minute, then cool and add water to make 50mL. Reference solution is prepared by mixing 0.45mL of 0.001N sulfuric acid, 1mL of hydrochloric acid(1→4) and water to make 50mL. When it is tested by Sulfate Limit Test, its content should be not more than 0.48% as SO_4 .

(2) Ferric salt : Weigh 2.0g of Sodium ferrous citrate, transfer into a flask with a ground-glass stopper, dissolve in 5mL of hydrochloric acid and 30mL of water, add 4g of potassium iodide, close a flask with a stopper, and allow to stand in a dark place for 15 minutes. Then, add 2mL of starch TS, and shake well. Even if a color develops, the color disappears on addition of 1.0mL of 0.1mol/l sodium thiosulfate to the solution.

(3) Lead : When 5.0 g of Sodium ferrous citrate is tested by Atomic Absorption Spectrophotometry or Inductively Coupled Plasma Emission Spectroscopy, its content should not be more than 1.0 ppm.

(4) Arsenic : It should be no more than 4.0 ppm tested by Arsenic Limit Test.

(5) Tartrate : Weigh 1.0g of Sodium ferrous citrate, add 5mL of water and 10mL of potassium hydroxide

solution(1→15), heat in a water bath for 10 minutes stirring well. Cool and filter. Measure 5mL of the filtrate, add diluted acetic acid(1→4) to make it weakly acidic, then add 2mL of acetic acid, and allow stand for 24 hours. No white, crystalline precipitate is formed.

Assay Accurately weigh about 1g of Sodium ferrous citrate, transfer into a flask with a ground-glass stopper, add 25mL of diluted sulfuric acid(1→20) and 2mL of nitric acid, and boil for 10 minutes. After cooling, add 20mL of water and 4g of potassium iodide, immediately close a flask with stopper tightly, allow to stand in a dark place for 15 minutes, add 100 mL of water and titrate the liberated iodine with 0.1 mol/l sodium thiosulfate(indicator: starch TS). Perform a blank test in the same manner.

1mL of 0.1 mol/l sodium thiosulfate = 5.585 mg of Fe

Sodium Fluoride

Chemical Formula: NaF

Molecular Weight: 41.99

Synonyms: Florocid

CAS No.: 7681-49-4

Content Sodium Fluoride, when calculated on the dried basis, should contain within a range of 98.0~102% of Sodium Fluoride(NaF).

Description Sodium Fluoride occurs as white powder and is odorless.

Identification

- (1) Sodium Fluoride is soluble in water but insoluble in ethanol.
- (2) 1 mg of Sodium Fluoride is transferred into a platinum crucible and 15 mL of sulfuric acid added. After covering with a glass plate, it is gently heated in a water bath. When the glass plate wash by flowing water, the dried surface of glass plate is corroded.
- (3) Sodium Fluoride solution(1→25) responds to the test for Sodium Salt reactions.

Purity

- (1) Free acid and Free Alkali : 2.0 g of Sodium Fluoride is weighed and transferred into a platinum dish. It is dissolved in 40 mL of water and then is added to 10 mL of a saturated solution of potassium nitrate. After cooling down it at 0°C, 3 drops of phenolphthalein solution is added and the following test is performed.
 - ① If the solution is colorless, add 2.0 mL of 0.1 N sodium hydroxide solution. A light red color develops.
 - ② If the solution is light red, add 0.5 mL of 0.1 N sulfuric acid. The color disappears.
- (2) Fluorinated silicate : Heat the test solution prepared in (1) Purity above until the solution boils. When the solution is hot, it is titrated with 0.1 N sodium hydroxide solution until its color is a light red. The consumed amount of sodium hydroxide solution should not be more than 1.5 mL.
- (3) Chloride : 0.3 g of Sodium Fluoride is dissolved in 20 mL of water. Add 0.2 g of boric acid and 1mL of nitrate in the above solution to make test solution. The test solution is proceed as directed under Chloride Limit Test. It should not be more than amount that corresponds to 1 mL of 0.001 N hydrochloric acid.
- (4) Lead : Sodium Fluoride is tested by purity (2) for 「Sodium Metaphosphate」(not more than 2.0 ppm).

Loss on Drying When Sodium Fluoride is dried at 150°C for 4 hours, the weight loss should not be more than 1%.

Assay 0.08 g of Sodium Fluoride is precisely weighed and dissolved in 25 mL of a mixture of acetic anhydride-glacial acetic acid(1:4). After cooling down it, it is titrated with 0.1 N perchloric acid solution (indicator : 1 mL of crystal violet buffered in glacial acetic acid). At the end point, the color of solution

turns to green. Separately, a blank test is done following the same procedure.

1 mL of 0.1 N perchloric acid solution = 4.199 mg NaF

Sodium Gluconate

Chemical Formula: $C_6H_{11}NaO_7$

Molecular Weight: 218.14

INS No.: 576

Synonyms: Sodium salt of D-gluconic acid

CAS No.: 527-07-1

[Content Specifications of Sodium Gluconate

Content Sodium Gluconate should contain within a range of 98.0~102.0% of sodium gluconate ($C_6H_{11}NaO_7$).

Description Sodium Gluconate is white ~ yellowish brown platelet or powder.

Identification (1) Sodium Gluconate solution (1→20) responds to the test for Sodium Salts in Identification.

(2) 0.7 mL of glacial acetic acid and 1 mL of freshly distilled phenyl hydrazine are added to 5 mL of warm Sodium Gluconate solution (1→10), which is then heated for 30 minutes in a water bath and cooled. When inner wall is scraped with a glass rod, crystallites are precipitated.

Purity (1) Lead : When 5.0 g of Sodium Gluconate is tested by Atomic Absorption Spectrophotometry or Inductively Coupled Plasma Emission Spectroscopy, its content should not be more than 2.0 ppm.

(2) Reduced Materials : Approximately 1 g of Sodium Gluconate is weighed and transferred into a 250 mL Erlenmeyer flask. 10 mL of water is added to dissolve the solid and 25 mL of alkaline copper citrate solution. A small beaker is placed on top of the flask, which is heated for precisely 5 minutes. It is then rapidly cooled to room temperature. To this solution, 25 mL of diluted acetic acid (1→10), 10 mL of 0.1N iodine solution, 10 mL of dilute hydrochloric acid, and 3 mL of starch solution are added. The resulting solution is titrated with 0.1 N sodium thiosulfate solution until the blue color disappears. The content of reduced materials should not be more than 0.5%.

$$\text{Content of Reduced Materials (as glucose)(\%)} = \frac{(V_1N_1 - V_2N_2) \times 27}{\text{weight of the sample(mg)}} \times 100$$

V_1 : Consumed amount of 0.1 N iodine solution (mL)

N_1 : Normality of 0.1 N iodine solution

V_2 : Consumed amount of 0.1 N sodium thiosulfate solution (mL)

N_2 : Normality of 0.1 N sodium thiosulfate solution

27 : Experimental corresponding amount for D-glucose

Assay Approximately 150 mg of Sodium Gluconate is weighed and dissolved in 75 mL of glacial acetic acid by heating. After cooling, quinidine red solution is added. The resulting solution is titrated with

0.1 N perchloric acid solution. The end point is where the color of the liquid disappears.

1 mL of 0.1 N perchloric acid solution = 21.81 mg $C_6H_{11}NaO_7$

• Quinaldine red solution : 100 mg of quinaldine red ($C_{21}H_{23}IN_2 = 430.33$) is dissolved in glacial acetic acid. Total volume of the solution is brought up to 100 mL with glacial acetic acid.

Sodium Hydrosulfite

Chemical Formula: $\text{Na}_2\text{S}_2\text{O}_4$

Molecular Weight: 174.11

CAS No.: 7775-14-6

Compositional Specifications of Sodium Hydrosulfite

Content Sodium Hydrosulfite should contain not less than 85.0% of sodium hydrosulfite ($\text{Na}_2\text{S}_2\text{O}_4$).

Description Sodium Hydrosulfite occurs as a white to gray-white crystalline powder. It is odorless or has a slight odor of sulfur dioxide.

Identification (1) To 10 mL of Sodium Hydrosulfite solution (1→100), add 1 mL of cupric sulfate solution. A gray-black color develops.

(2) To 10 mL of Sodium Hydrosulfite solution (1→100), add 1 mL of potassium permanganate solution. The color of the solution disappears.

(3) Sodium Hydrosulfite responds to the test for Sodium Salt (A) and (B) in Identification.

Purity (1) Clarity and Color of Solution : To 10 mL of formalin, add 10 mL of water, and neutralize with sodium hydroxide solution. Take 10 mL of the solution, weigh 0.5 g of Sodium Hydrosulfite, dissolve in the solution, and allow to stand for 5 minutes. The solution should not be more than slightly turbid.

(2) Arsenic : It should be no more than 4.0 ppm tested by Arsenic Limit Test.

(3) Lead : Sodium Hydrosulfite is tested by Purity (2) for Sodium Metaphosphate(not more than 2 ppm).

(4) Zinc : Take 5 mL of the solution A prepared in (3) above, add 0.1 mL of ammonia solution, filter, add water to make 20 mL, add 5 mL of diluted hydrochloric acid and 0.1 mL of freshly prepared potassium ferrocyanide solution, and allow to stand for 15 minutes. The solution is not more turbid than the following reference solution. To prepare reference solution, measure 8 mL of Zinc Standard Solution, transfer into a Nessler tube, add water to make 20 mL. add 5 mL of diluted hydrochloric acid and 0.1 mL of freshly prepared potassium ferrocyanide solution, add water, and allow to stand for 15 minutes.

(5) Disodium Ethylenediaminetetraacetate : Weigh 0.5 g of Sodium Hydrosulfite, dissolve in 5 mL of water, add 2 mL of 0.5% potassium chromate solution and 2 mL of arsenic trioxide solution. and heat in a water bath for 2 minutes. No purple color develops.

(6) Formic acid : To 10 mL of Sodium Hydrosulfite solution(1→1,000), add 5 mL of diluted hydrochloric acid (1→2), and add about 0.3 g of magnesium dust in small portions. After effervescence is almost no longer evolved, cover with a watch glass, and allow to stand for 2 hours. Measure 1 mL of this solution, add 2 mL of sulfuric acid and 0.5 mL of chromotropic acid solution, and heat in a water bath for 10 minutes. The color of the solution is not darker than that of the following reference solution. The reference solution is acquired by separately measuring 1 mL of diluted formaldehyde standard solution instead of sample and preparing in the same manner as sample.

Assay Add 10 mL of water to 10 mL of formalin, and neutralize with sodium hydroxide solution. To this

solution, add about 2 g of Sodium Hydrosulfite, accurately weighed, and dissolve in water to make exactly 500 mL. Take 25 mL of this solution, adjust the pH to 1.1 ~ 1.5 with diluted hydrochloric acid (1→10), and titrate with 0.1 N iodine solution for sodium hydrosulfite (indicator : starch solution).

1 mL of 0.1 N iodine solution = 4.353 mg of $\text{Na}_2\text{S}_2\text{O}_4$

Sodium Hydroxide

Chemical Formula: NaOH

Molecular Weight: 40.00

INS No.: 524

Synonyms: Caustic soda; Lye

CAS No.: 1310-73-2

Definition Sodium Hydroxide occurs as crystals called Sodium Hydroxide (crystal) and as Anhydrous called Sodium Hydroxide (Anhydrous). Sodium Hydroxide (crystal) is a mixture of sodium hydroxide (NaOH, Anhydrous) and sodium hydroxide hydrated (NaOH · H₂O, Mono hydrated).

Compositional Specifications of Sodium Hydroxide

Content Sodium Hydroxide (crystal) should contain within a range of 70.0 ~ 75.0% of sodium hydroxide (NaOH). Sodium Hydroxide (Anhydrous) should contain not less than 95.0% of sodium hydroxide (NaOH).

Description Sodium Hydroxide (crystal) occurs as white crystalline powder or granules. Sodium Hydroxide (Anhydrous) occurs as white lumps having various shapes including pellets, flakes, and rods, or as a white powder.

Identification (1) Sodium Hydroxide solution (1→50) is strongly alkaline.

(2) Sodium Hydroxide solution (1→25) responds to the test for Sodium Salt in Identification.

Purity (1) Clarity and Color of Solution : Dissolve 50 g of Sodium Hydroxide in freshly boiled and cooled water to make 250 mL, Test Solution. When 5 mL of this test solution is mixed with 20 mL of water, the solution should be colorless and should not be more than almost clear.

(2) Sodium Carbonate : The content of Sodium Carbonate (Na₂CO₃) obtained in Assay is not more than 2%.

(3) Arsenic : It should be no more than 4.0 ppm tested by Arsenic Limit Test.

(4) Lead : Sodium Hydroxide is tested by purity (2) for 「Sodium Metaphosphate」(not more than 0.5 ppm).

(5) Mercury : Take 10 mL of the test solution prepared in (1) above, add 1 mL of potassium permanganate solution (3→50) and about 30 mL of water, and shake. Neutralize by gradually adding purified hydrochloric acid, add 5 mL of diluted sulfuric acid (1→2). and cool, Test Solution. Add hydroxylamine hydrochloride solution (1→5) until the purple color of the potassium permanganate in the test solution disappears and the precipitate of manganese dioxide dissolves, add water to make 100 mL, and transfer into the gas washing bottle of an atomic absorption spectrophotometer. Add 10 mL of stannous chloride solution, immediately connect with the atomic absorption spectrophotometer, and start the diaphragm pump to circulate the air. When the recorder reading increases rapidly and then it indicates a constant value, measure the absorbance. The absorbance is not more than that of the following

solution. Measure 2 mL of Mercury Standard Solution, add 1 mL of potassium permanganate solution (3→50), 30 mL of water, and the same amount of purified hydrochloric acid as that used for preparing the test solution, and proceed in the same manner as the test solution. The content should not be more than 0.1 ppm as Hg.

Assay Accurately weigh about 50 g of Sodium Hydroxide, add freshly boiled and cooled water to make 1,000 mL. Use this solution as the test solution. Take 25 mL of the test solution, add 10 mL of freshly boiled and cooled water, and titrate with 1 N hydrochloric acid (indicator : 1 mL of bromophenol blue solution). After neutralizing, add about 1 mL of 1 N hydrochloric acid, and boil for about 5 minutes. After cooling, titrate the excess acid with 0.1 N sodium hydroxide, and determine the volume (A mL) of consumed 1 N hydrochloric acid. Separately, measure exactly 25 mL of the test solution, transfer into a flask with a ground-glass stopper, and add 25 mL of freshly boiled and cooled water. To the solution. add 10 mL of barium chloride solution. stopper, shake gently, and titrate with 1 N hydrochloric acid (indicator: 1 mL of phenolphthalein solution). Let (B mL) be the consumed volume.

$$\text{Content of sodium hydroxide(NaOH)(\%)} = \frac{0.0400(\text{g}) \times B \times 40}{\text{weight of the sample}(\text{g})} \times 100$$

$$\text{Content of sodium carbonate(Na}_2\text{CO}_3\text{)(\%)} = \frac{0.0530(\text{g}) \times (A-B) \times 40}{\text{weight of the sample}(\text{g})} \times 100$$

Sodium Hydroxide Solution

Compositional Specifications of Sodium Hydroxide Solution

Content Sodium Hydroxide Solution should contain within a range of 95.0 ~ 120% of the declared content of sodium hydroxide ($\text{NaOH} = 40.00$).

Description Sodium Hydroxide Solution is a colorless or slightly colored liquid.

Identification (1) Sodium Hydroxide Solution (1→50) is strongly alkaline.

(2) Sodium Hydroxide Solution (4% as NaOH calculated from the declared content) responds to the test for Sodium Salt in Identification.

Purity (1) Clarity and Color of Solution : To Sodium Hydroxide Solution, add freshly boiled and cooled water to prepare 20% solution as Sodium Hydroxide which is calculated from the declared content, Test Solution. When 5 mL of this test solution is mixed with 20 mL of water, the solution should be colorless and should not be more than almost clear.

(2) Sodium Carbonate : The content of Sodium Carbonate (Na_2CO_3) obtained in Assay is not more than 2.0%.

(3) Arsenic : It should be no more than 4.0 ppm tested by Arsenic Limit Test.

(4) Lead : Sodium Hydroxide Solution is tested by purity (2) for 「Sodium Metaphosphate」(not more than 2.0 ppm).

(5) Mercury : When Sodium Hydroxide Solution is tested by Mercury Limit Test, its content should not be more than 0.1 ppm.

Assay Accurately weigh about Sodium Hydroxide Solution corresponding to about 5 g of sodium hydroxide (NaOH). Add freshly boiled and cooled water to make exactly 100 mL, and use this solution as the test solution. Take 25 mL of the test solution, and proceed as directed under Assay in 「Sodium Hydroxide」. However, the number 40 in the equation is replaced with 4.

Sodium Hypochlorite

Chemical Formula: NaClO

Molecular Weight: 74.45

CAS No.: 7681-52-9

Definition The major component of this item is sodium hypochlorite. It includes acquiring saline solution by electrolysis.

Compositional Specifications of Sodium Hypochlorite

Content Sodium Hypochlorite should contain not less than 4.0% of available chlorine. Acquired saline solution by electrolysis should contain not less than 100ppm.

Description Sodium Hypochlorite is a colorless to light green-yellow liquid having an odor of chlorine.

Identification (1) When Sodium Hypochlorite is tested by Flame Coloration Test, it shows yellow.

(2) When diluted hydrochloric acid is added to Sodium Hypochlorite, gas is generated.

(3) Dip a red litmus paper in Sodium Hypochlorite. The color of the litmus paper changes to blue, and then fades.

Assay Accurately weigh about 3 g of Sodium Hypochlorite, add 50 mL of water, 2 g of potassium iodide and 10 mL of diluted acetic acid. Titrate the liberated iodine with 0.1 N sodium thiosulfate (indicator : starch solution). Separately, perform a blank test in the same manner, and make any necessary correction. However, pipette 10 mL of sodium hypochlorite water into a beaker, which is prepared by preparation equipment of sodium hypochlorite. Add 50 mL of water, 1 g of potassium iodide and 10 mL of acetic acid. Titrate free iodine with 0.01 N sodium thiosulfate.

1 mL of 0.1 N sodium thiosulfate = 3.546 mg of Cl

Sodium Iron Chlorophyllin

Compositional Specifications of Sodium Iron Chlorophyllin

Description Sodium Iron Chlorophyllin occurs as a green-black powder. It is odorless or has a slight, characteristic odor.

Identification (1) Add 5 mL of diluted hydrochloric acid to ignition residue, dissolve in a water bath, add water to make 10 mL, make it weakly alkaline with ammonia solution. add 10 mL of hydrogen sulfide solution, allow to stand for 30 minutes, and filter. Perform the following tests for the filtrate and the residue on the filter paper.

① To the filtrate, add 1 mL of diluted hydrochloric acid. and perform Flame Coloration Test. The color of the flame is yellow.

② Dissolve the residue on the filter paper with 2 mL of diluted nitric acid. add water to make 5 mL, and add 2 ~ 3 drops of ammonium thiocyanate solution. A red color develops.

(2) 0.1 g of Sodium Iron Chlorophyllin, add water to make 1000 mL. Take 10 mL of this solution, add phosphate buffer (pH 7.5) to make 100 mL, and measure the absorbance. The solution exhibits absorption maxima at wavelengths of 397 ~ 399 nm and 654 ~ 656 nm. When the absorbances at the absorption maxima are expressed as A1 and A2, respectively, A1/A2 should not be more than 9.5.

Purity (1) pH : 1 g of Sodium Iron Chlorophyllin, dissolved in 100 mL of water. pH of this solution is 9.5 ~ 11.0.

(2) Specific Absorbance : Accurately weigh about 0.1 g of Sodium Iron Chlorophyllin, dissolve in water to make exactly 1000 mL. Take 1 mL of this solution add phosphate buffer (pH 7.5) to make exactly 100 mL, measure the absorbance quickly at the absorption maximum near a wavelength of 398 nm, and calculate on the dried basis.

$$E_{1\text{cm}}^{1\%} = \text{Not less than 400}$$

Avoid direct sunlight during the procedure. and use light-resistant containers.

(3) Arsenic : It should be no more than 4.0 ppm tested by Arsenic Limit Test.

Loss on Drying When Sodium Iron Chlorophyllin is dried for 2 hours at 105°C, the loss should not be more than 5.0%.

Sodium Lactate

Sodium Lactate Solution

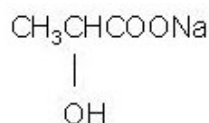

Chemical Formula: $\text{C}_3\text{H}_5\text{NaO}_3$

Molecular Weight: 112.06

INS No.: 325

Synonyms: Sodium 2-hydroxypropanoate

CAS No.: 72-17-3

Compositional Specifications of Sodium Lactate

Content Sodium Lactate should contain not less than 50.0% of sodium lactate ($\text{C}_3\text{H}_5\text{NaO}_3$) and 98.0 ~ 102.0% of the declared content.

Description Sodium Lactate is a colorless, clear, syrupy liquid. It is odorless or has a slight, characteristic odor.

Identification Sodium Lactate responds to the tests for Sodium Salt and Lactate in Identification.

Purity (1) pH : pH of Sodium Lactate should be within a range of 5.0 ~ 9.0.

(2) Citric acid, Oxalic acid, Tartaric acid, and Phosphoric acid : 5 mL of Sodium Lactate is diluted to 50 mL with freshly boiled and cooled water. pH of 4 mL of this solution is adjusted to 7.3 ~ 7.7 with 6 N ammonium hydroxide solution or 3 N hydrochloric acid, if necessary. When 1 mL of calcium chloride solution is added and boiled for 5 minutes in a water bath, it should not turn turbid.

(3) Sulfate : Weigh the amount of Sodium Lactate corresponding to 4.0 g of sodium lactate and the content should not be more than amount that corresponds to 0.5 mL of 0.01 N sulfuric acid.

(4) Cyanide : Weigh the amount of Sodium Lactate corresponding to 20 g of Sodium Lactate and transfer into a 100 mL of flask, where water is added to bring the total volume to 100 mL (Test Solution). Separately, 10 mL of sodium hydroxide solution transfer into a 100 mL flask, where 100 mg of potassium cyanide is added. 0.1 N sodium hydroxide solution is added to bring the total volume to 100 mL. Precisely 10 mL of this solution transfer into a 1,000 mL flask, which is then filled to 1,000 mL with 0.1 N sodium hydroxide solution (cyanide standard solution, which contains 10 μg per 1 mL). 10 mL of Test Solution transfer into a 50 mL beaker, while 0.1 mL of cyanide standard solution and 10 mL of water are placed in another 50 mL beaker. These beakers are placed in an ice bath and pH of the solutions are adjusted to 9 ~ 10 with 20% sodium hydroxide solution. To avoid over heating, 20% sodium hydroxide solution is slowly added while stirring. After settling for 3 minutes, pH of the solutions are adjusted to 5 ~ 6 with 10% phosphoric acid using a pH meter. These solutions are transferred into 100 mL separatory funnels containing 25 mL of cold water. Beakers and electrodes of

pH meter are washed with a few mL of cold water into the separatory funnels. 2 mL of bromine solution is added and the funnel is capped with a stopper and then mixed. 2 mL of 2% sodium arsenic solution is added and then the funnel is capped and then mixed. 10 mL each of n-butyl alcohol is added to each transparent solution, a stopper is placed, and the solution is mixed. Finally, 5 mL mixture of p-phenylenediamine-pyridine is added, mixed, and set aside for 15 minutes. Aqueous phase is removed and alcoholic phase is filtered through a filter paper. When absorbance of each Test and Standard solution is measured at 480 nm using 1 cm path length. Absorbance of Test Solution should not be bigger than that of Standard Solution.

Solutions

◦ p-phenylenediamine-pyridine mixed solution : 200 mg of p-phenylenediamine hydrochloric acid is completely dissolved in 100 mL of water by heating. After cooling, the solution is settled to precipitate. The supernatant is used to prepare mixed solution. 128 mL of pyridine is dissolved in 365 mL of water, where 10 mL of hydrochloric acid is added and mixed. 30 mL of p-phenylenediamine solution is added to the resulting solution, which is settled for 24 hours before use. When this mixed solution is stored in a brown bottle, it is stable for 3 weeks.

(5) Arsenic : It should be no more than 1.3 ppm tested by Arsenic Limit Test.

(6) Lead : When 5.0 g of Sodium Lactate is tested by Atomic Absorption Spectrophotometry or Inductively Coupled Plasma Emission Spectroscopy, its content should not be more than 2.0 ppm.

(7) Mercury : When Sodium Lactate is tested by Mercury Limit Test, its content should not be more than 1.0 ppm.

(8) Chloride : Weigh the amount of Sodium Lactate corresponding to 0.5 g of Sodium Lactate and the content should not be more than amount that corresponds to 0.7 mL of 0.01 N hydrochloric acid.

(9) Methanol and Methyl ester : 40 g of Sodium Lactate is transferred into a round bottom flask, where 10 mL of water is added followed by carefully adding 30 mL of 5 N potassium hydroxide solution. It is then distilled with a condenser. 10 mL of alcohol is previously added to the collecting vessel of the condenser. It is distilled until approximately 95 mL is collected. Water is added to bring the total volume to 100 mL (Test Solution). Separately, a standard solution is prepared so that it contains 10 mg of methyl alcohol in 100 mL of diluted alcohol (1→10). 10 mL each of Test and Standard Solution is transferred into a 25 mL flask, respectively. 5 mL each of potassium permanganate-phosphoric acid solution is added, mixed, and set aside for 15 minutes, where 2 mL each of oxalic acid-sulfuric acid solution is added and stirred with a glass rod until it becomes clear. 5 mL of puccine sulfite solution is added and water is added to bring the total volume to 25 mL. After 2 hours, absorbances of Test and Standard Solutions near the maximum absorption band near 575 nm are measured using water as a reference and 1cm path length. The absorbance of Test Solution should not be bigger than that of Standard Solution.

Solutions

◦ Potassium permanganate-Phosphoric acid solution : 3 g of potassium permanganate is added to a

mixture of 15 mL of phosphoric acid and 70 mL of water. Water is added to bring the total volume to 100 mL.

• Oxalic acid-Sulfuric acid solution : 50 mL of sulfuric acid is carefully added to 50 mL of water. After cooling, 5 g of oxalic acid is added and mixed until it dissolves.

(10) Sugars : When 5 drops of Sodium Lactate is added to 10 mL of hot Fehling's solution, red precipitates should not be formed.

Assay Weigh precisely the amount of Sodium Lactate corresponding to 0.3 g of Sodium Lactate and place in a flask. Add 60 mL of mixture of anhydrous acetic acid-glacial acetic acid (1:4) and mix that. After settling for 20 minutes, it is titrated with 0.1 N perchloric acid solution (indicator : 1 mL of crystal violet · glacial acetic acid solution). The end point is where the color of the solution changes from blue to green. Separately, a blank test is carried out in the same manner.

1 mL of 0.1 N perchloric acid solution 1 mL = 11.21 mg $C_3H_5NaO_3$

Sodium Lauryl Sulfate

INS No.: 487

Synonyms: Sodium dodecyl sulfate

CAS No.: 151-21-3

Definition Sodium Lauryl Sulfate is a mixture of sodium alkylsulfates consisting chiefly of sodium lauryl sulfate $[\text{CH}_3(\text{CH}_2)_{10}\text{CH}_2\text{OSO}_3\text{Na}]$.

Compositional Specifications of Sodium Lauryl Sulfate

Content Sodium Lauryl Sulfate should contain no less than 59.0% of total alcohols.

Description Sodium Lauryl Sulfate occurs as white or light yellow crystals having a slightly characteristic odor.

Identification (1) Sodium Lauryl Sulfate solution (1→10) responds to the test for Sodium Salt.

(2) Sodium Lauryl Sulfate solution (1→10) responds to the test by Sulfate Limit Test after acidification with hydrochloric acid and boiling gently for 20 min.

Purity (1) Alkalinity: 1.0 g of Sodium Lauryl Sulfate is dissolved in 100 mL of water, where phenol red solution is added. This solution is titrated with 0.1 N hydrochloric acid. The consumption should not be more than 0.5 mL.

(2) The content of Sodium Chloride and Sodium Sulfate : When the test proceed as directly under Sodium Chloride and Sodium Sulfate, the content of Combined Sodium Chloride and Sodium Sulfate should not be more than 8.0% when tested by following tests.

① Sodium chloride: Dissolve about 5 g, precisely weighed, in 50 mL of water. If necessary, neutralize the solution with dilute nitric acid, add 2 mL of potassium chromate solution, and titrate with 0.1 N silver nitrate. Perform blank test with the same method.

1 mL of 0.1 N silver nitrate = 5.844 mg of NaCl

② Sodium sulfate: Dissolve about 1 g, accurately weighed, in 10 mL of water, heat the mixture, and stir until completely dissolved. Add 100 mL of alcohol to the hot solution and digest at a temperature just below the boiling point for 2 h. Filter while hot through a sintered-glass filter crucible (G4), and wash the precipitate with 100 mL of hot alcohol. Dissolve the precipitate in the crucible by washing with about 150 mL of water, collecting the washing in a beaker. Acidify with 10 mL of hydrochloric acid, heat to boiling, add 25 mL of barium chloride solution, and allow to stand overnight. Collect the precipitate of barium sulfate on a suitable tared, porous-bottom porcelain filter crucible, wash until free from chloride, dry, and ignite to constant weight at 800°C

Weight of sodium sulfate (%) = The weight of barium sulfate (g) x 0.6086/weight of sample (g) x 100

(3) Unsulfated alcohols: Dissolve approximately 10 g of Sodium Lauryl Sulfate, precisely weighed, in 100 mL of water, and add 100 mL of alcohol. Transfer the solution to a separator, and extract with three 50 mL portions of solvent hexane. If an emulsion forms, add sodium chloride to promote separation of the two layers. Wash the combined solvent hexane extracts with three 50 mL portions of water, and dry with anhydrous sodium sulfate. Evaporate hexane on a steam bath until odor is no longer perceptible, when calculated on the dried basis at 105°C for 30 minutes and weighed, the amount should not be more than 4.0 %.

(4) Lead : When 5.0 g of Sodium Lauryl Sulfate is tested by Atomic Absorption Spectrophotometry or Inductively Coupled Plasma Emission Spectroscopy, its content should not be more than 5 ppm.

Assay 150 mL of water and 50 mL of hydrochloric acid are added to 5 g of precisely weighed Sodium Lauryl Sulfate, which is boiled for approximately 4 hours with a reflux condenser. After cooling, it is extracted twice with 75 mL each of ether. Ether extracts are combined and washed with water. Ether is removed by evaporation in a water bath. The residue is dried at 105°C for 30 minutes and weighed. The residue represents the total alcohols.

Sodium DL-Malate

Sodium *d/l*-Malic Acid

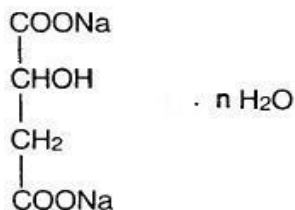

Chemical Formula: $\text{C}_4\text{H}_4\text{O}_5\text{Na}_2 \cdot n\text{H}_2\text{O}$ ($n = 3$ or $1/2$)

Molecular Weight: 232.10(3 hydrates)

187.06(1/2 hydrates)

INS No.: 350(ii)

Synonyms: Malic acid sodium salt

CAS No.: 676-46-0

Definition Sodium DL-Malate occurs as trihydrate and hemihydrate.

Compositional Specifications of Sodium DL-Malate

Content Sodium DL-Malate, when calculated on the dried basis, should contain within a range of 98.0 ~ 102.0% of Sodium DL-Malate ($\text{C}_4\text{H}_4\text{O}_5\text{Na}_2 = 178.07$).

Description Sodium DL-Malate occurs as white crystalline powder or lumps. It is odorless and has a salty taste.

Identification (1) Proceed as directed under Identification (1) in 「DL-Malic Acid」.

(2) Place Sodium DL-Malate solution (1→20) into a porcelain dish, add 10 mg of sulfanilic acid, and proceed as directed under Identification (1) in 「DL-Malic Acid」.

(3) Sodium DL-Malate responds to the test for Sodium Salt in Identification.

Purity (1) Clarity and Color of Solution : When 1 g of Sodium DL-Malate is dissolved in 10 mL of water, the solution should be colorless and clear.

(2) Free Alkali : Weigh 1 g of Sodium DL-Malate, dissolve in 20 mL of freshly boiled and cooled water, and add 2 drops of phenolphthalein solution. Even if become to pink color, the color disappears on addition of 0.4 mL of 0.1 N sulfuric acid.

(3) Chloride : When 1 g of Sodium DL-Malate is tested by Chloride Limit Test, its content should not be more than the amount that corresponds to 0.3 mL of 0.01 N hydrochloric acid.

(4) Arsenic : It should be no more than 4.0 ppm tested by Arsenic Limit Test.

(5) Lead : When 5.0 g of Sodium DL-Malate is tested by Atomic Absorption Spectrophotometry or Inductively Coupled Plasma Emission Spectroscopy, its content should not be more than 2.0 ppm.

(6) Mercury : When Sodium DL-Malate is tested by Mercury Limit Test, its content should not be more than 1.0 ppm.

(7) Readily Oxidized Matters : Weigh 0.1 g of Sodium DL-Malate, dissolve in 25 mL of water and 25 mL

of diluted sulfuric acid (1→20), and maintain at 20°C. Add 1.0 mL of 0.1 N potassium permanganate and the pink color of the solution should not disappear within 3 minutes.

Loss on Drying When Sodium DL-Malate is dried for 4 hours at 130°C, the weight loss of trihydrate hydrate should be within a range of 20.5 ~ 23.5% and the weight loss of hemihydrate should not more than 7%.

Residue on Ignition Sodium DL-Malate is dried for 4 hours at 130°C. When thermogravimetric analysis is done with dried material, the residue should be within a range of 78.2 ~ 84.4%.

Assay Dissolve 0.15 g of Sodium DL-Malate, precisely dried and accurately weighed, in 30 mL of acetic acid (for non-aqueous titration). Then it is titrated with 0.1 N perchlorate solution. Potentiometer is used to confirm the end point. When the indicator (1 mL of crystal violet-acetic acid) is used, the end point is the point where the color turns from red through blue and to green. Separately in the same method, the blank test is performed.

1 mL of 0.1 N perchlorate solution = 8.903 C₄H₄Na₂O₅.

Sodium Metabisulfite

Sodium Pyrosulfite

Chemical Formula: $\text{Na}_2\text{S}_2\text{O}_5$

Molecular Weight: 190.11

INS No.: 223

Synonyms: Sodium pyrosulfite

CAS No.: 7681-57-4

Compositional Specifications of Sodium Metabisulfite

Content Sodium Metabisulfite should contain not less than 95.0% of sodium metabisulfite ($\text{Na}_2\text{S}_2\text{O}_5$).

Description Sodium Metabisulfite is white crystallite or crystalline powder with odor of sulfur dioxide.

Identification Sodium Metabisulfite responds to the test for SO_3^{2-} bisulfite and sodium salts in Identification.

Purity (1) Clarity and Color of Solution : When 1 g of Sodium Metabisulfite is dissolved in 10 mL of water, the turbidity of the solution should be slightly turbid or better.

(2) pH : pH of Sodium Metabisulfite solution (1→10) should be within a range of 4.0 ~ 4.5.

(3) Thiosulfate : When 10% of Sodium Metabisulfite solution is acidified with sulfuric acid or hydrochloric acid, the solution should be transparent.

(4) Arsenic : It should be no more than 4.0 ppm tested by Arsenic Limit Test.

(5) Lead : Sodium Metabisulfite is tested by purity (2) for 「Sodium Metaphosphate」(not more than 2.0 ppm).

(6) Mercury : When Sodium Metabisulfite is tested by Mercury Limit Test, its content should not be more than 1.0 ppm.

(7) Iron : When 5.0 g of Sodium Metabisulfite is tested by Atomic Absorption Spectrophotometry or Inductively Coupled Plasma Emission Spectroscopy, its content should not be more than 10 ppm.

(8) Selenium : Transfer 2.0 g of Sodium Metabisulfite, precisely weighed, into a 50 mL beaker, add 10 mL of water and 5 mL of hydrochloric acid and boil to remove sulfur dioxide, Test Solution. Separately, 1.0 g of Sodium Metabisulfite is precisely weighed into a beaker, where 0.5 mL of selenium standard solution is added. Then a reference solution is prepared by the same manner as for test solution. 2 g of hydrazin sulfate is added into each beaker, heated and dissolved. After setting for 5 minutes, the resulting solution is transferred into a Nestler cylinder with adding water to make 50 mL. The red color of this test solution should not be deeper than that of reference solution. (Not more than 5 ppm)

Assay Approximately 0.2 g of Sodium Metabisulfite, precisely weighed, is transferred into a flask with a stopper filled with 50 mL of 0.1 N iodine solution. It is then dissolved. The stopper is placed and the flask is set-aside for 5 minutes. After 1 mL of hydrochloric acid is added, the excess iodine is titrated with 0.1 N sodium thiosulfate solution (indicator : starch solution).

1 mL of 0.1 N iodine solution = 4.753 mg of $\text{Na}_2\text{S}_2\text{O}_5$

Sodium Metaphosphate

INS No.: 452(i)

Synonyms: Graham's salt; Sodium hexametaphosphate;
Sodium tetrapolyphosphate

CAS No.: 10361-03-2

Compositional Specifications of Sodium Metaphosphate

Content Sodium Metaphosphate, when calculated on the dried basis, should contain within a range of 60.0 ~ 83.0% of phosphorus pentoxide ($P_2O_5 = 141.95$).

Description Sodium Metaphosphate occurs as colorless ~ white glassy lump, flakes, or white fibrous crystals or powder.

Identification (1) Sodium Metaphosphate solution (1→40) weakly acidic with diluted acetic acid or sodium hydroxide solution, add 5 mL of egg white solution. A white precipitate is formed.

(2) A solution of Sodium Metaphosphate (1→20) responds to the test for Sodium Salt in Identification.

Purity (1) Arsenic : It should be no more than 4.0 ppm tested by Arsenic Limit Test.

(2) Lead : Accurately weigh 5.0 g of Sodium Metaphosphate, transfer into a 150 mL beaker, add 30 mL of water, hydrochloric acid in small portion to the solution until the solid is dissolved thoroughly, and then add 1 mL of hydrochloric acid again. Heat this solution for about 5 minutes and cool down. Add water to make 100 mL, and adjust within a range of pH of 2~4 with sodium hydroxide solution(1→4) or hydrochloric acid(1→4). Transfer this solution into 250 mL separatory funnel, where water is added to make 200 mL. Then add 2 mL of 2% APDC solution and shake to mix. Extract the solution 2 times with 20 mL each of chloroform, which is evaporated to dryness in a water bath. Add 3 mL of Nitric Acid to the residue and heat it until nearly evaporated. To this solution, add 0.5 mL of Nitric Acid and 10 mL of water, concentrate it until the final solution becomes 3 ~ 5 mL, and add water to make 10 mL, Test Solution. When the test solution is tested by Atomic Absorption Spectrophotometry or Inductively Coupled Plasma Emission Spectroscopy, its content should not be more than 4.0 ppm.

(3) Cadmium : When the test solution of (2) in Purity is tested by Atomic Absorption Spectrophotometry or Inductively Coupled Plasma Emission Spectroscopy, its content should not be more than 1.0 ppm.

(4) Mercury : When Sodium Metaphosphate is tested by Mercury Limit Test, its content should not be more than 1.0 ppm.

(5) Fluoride : 10.0 g of Sodium Metaphosphate is precisely weighed and is tested by purity (8) for 「Calcium Citrate」(not more than 10 ppm).

Loss on Drying When Sodium Metaphosphate is dried for 4 hours at 110°C, the weight loss should not be more than 5%.

Assay To about 0.2 g of Sodium Metaphosphate, previously dried and accurately weighed, add 5 mL of nitric acid and 25 mL of water. It is then boiled for 30 minutes while adding water to supplement evaporating water. After cooling, add water to make 500 mL. It is used as the Test Solution which is filtered through a dried filter paper, if necessary. Take 5 mL of Test Solution, and add 20 mL of vanadate · molybdate solution and water to make 100 mL. It is mixed well by shaking and set-aside for 30 minutes. Absorbance of this solution is measured at 400 nm with 1cm path length. A reference solution is prepared by the same procedure with 5 mL of water instead of Test Solution. Separately, 10 mL of potassium phosphate, monobasic standard solution is mixed with 20 mL of diluted nitric acid (1→25) and water to make 250 mL. With 10 mL, 15 mL, and 20 mL each of this solution, same procedure is followed to measure absorbances, from which a calibration curve is prepared. From the calibration curve and the absorbance of Test Solution, the amount of Phosphorus(g) in 5 mL of Test Solution is obtained. The content of P₂O₅ is calculated from the following equation.

$$\text{Content of P}_2\text{O}_5(\%) = \frac{\text{Weight of P(g) in 5mL of Test Solution} \times 2.291 \times 100}{\text{weight of the sample(g)}} \times 100$$

Sodium Metasilicate

Chemical Formula: $\text{Na}_2\text{O}\cdot\text{SiO}_2\cdot n\text{H}_2\text{O}$ ($n = 5$ or 0)

INS No.: 550(ii)

Molecular Weight: 212.06(5hydrates)

CAS No.: 6834-92-0

122.06(anhydrous)

Definition Sodium Metasilicate is an anhydrous or hydrous (pentahydrate) silicate having a 1:1 molar ratio of Na_2O to SiO_2 .

Compositional Specifications of Sodium Metasilicate

Content Sodium Metasilicate should contain within a range of 90.0 ~ 110.0% as indicated the percent, each, of SiO_2 and Na_2O .

Description Sodium Meatsilicate occurs as a white granular material.

Identification (1) Place a drop of Sodium Meatsilicate solution (2→100) on a spot plate. Add to this 1 drop of 4 M sodium hydroxide and 1 drop of a solution prepared by dissolving 0.5 g of ammonium molybdate in 10 mL of water, followed by the addition of 3 mL of sulfuric acid. A deep-yellow color indicates the presence of silicate.

(2) Dip a clean nichrome wire into Sodium Meatsilicate solution (2→100) and place the wire in the flame of a Bunsen burner. A bright-yellow color indicates the presence of sodium.

Purity (1) Heavy metals: Transfer 10 g of Sodium Metasilicate to a 250-mL beaker, add 50 mL of 0.5 N hydrochloric acid, cover with a watch glass, and heat slowly to boiling. Boil gently for 15 min, cool, and let the undissolved material settle. Decant the supernatant liquid through Whatman No. 4 (or an equivalent) filter paper. Wash the slurry and beaker with four 10-mL portions of hot water, decanting each washing through the filter into the flask. Cool the filtrate, dilute with water to 100 mL, and mix to obtain the sample solution. Take 20 mL of the sample solution, add 1 drop of phenolphthalein solution, neutralize with ammonia solution and add 2 mL of dilute acetic acid. When performed heavy metal test with this solution, the quantity should not be more than 10 ppm.

Loss on Drying Dry at 105°C for 2 hour. It should not be more than 2.0% for the anhydrous and 42.0% for the pentahydrate.

Loss on Ignition Dry at 105°C for 2 hour and ignite about 1 g, precisely weighed, at 1000°C for 2 hour. It should not be more than 0.5% for the anhydrous and be between 40.5% and 42.5% for the pentahydrate.

Assay (1) Silicon Dioxide: In a beaker, acidify 1 g of Sodium Metasilicate, precisely weighed, with 5 mL of hydrochloric acid, and evaporate to dryness on a steam bath. Repeat the treatment with an additional 5 mL of hydrochloric acid, mix the residue with 1 mL of hydrochloric acid and 20 mL of water, and heat for 1.5 hr on a steam bath. Cool, filter through an ashless filter paper, and wash the paper and the residue thoroughly with hot water. Transfer the filter paper to a platinum crucible and dry at

105°C for 2 hr. Gradually increase the heat to burn away the paper, ignite the crucible and its contents to constant weight at 1000°C, cool in a desiccator, and weigh. Moisten the ignited residue with few drops of water, add 15 mL of hydrofluoric acid and 5 drops of sulfuric acid (1:3), and heat the crucible gradually until all of the acid is driven off. Ignite the residue to constant weight at 1000°C, cool the crucible in a desiccator, and weigh. The loss in weight is equivalent to the weight of SiO₂ in the sample taken.

(2) Sodium Oxide: Disperse 500 mg of Sodium Metasilicate, precisely weighed, in 150 mL of water, and heat on a steam bath. Cool and add 2 to 3 drops of phenolphthalein solution and 100 mL of 0.1 N sulfuric acid. Titrate an excess acid with 0.1 N sodium hydroxide. Subtract the volume of 0.1 N sodium hydroxide from the volume of 0.1 N sulfuric acid.

1 mL of 0.1 N sulfuric acid = 3.099 mg Na₂O

Sodium Methoxide

Chemical Formula: CH₃ONa

Molecular Weight: 54.02

CAS No.: 124-41-4

Compositional Specifications of Sodium Methoxide

Content Sodium Methoxide should contain not less than 95.0% of sodium methoxide (CH₃ONa).

Description Sodium Methoxide occurs as a white, hygroscopic, fine power.

Identification (1) Sodium Methoxide solution (1→100) is alkaline.

(2) To 1 drop of Sodium Methoxide solution (1→100), add 0.1 mL of diluted sulfuric acid (1→20) and 0.2 mL of potassium permanganate solution (1→300), and allow to stand for 5 minutes. Add 0.2 mL of anhydrous sodium sulfite solution (1→4) and 3 mL of sulfuric acid, and then add 0.2 mL of chromotropic acid solution. A red-purple to purple color develops.

(3) Sodium Methoxide responds to the test for Sodium Salt in Identification.

Purity (1) Clarity and Color of Solution : Weigh 5 g of Sodium Methoxide, and dissolve in freshly boiled and cooled water to make 100 mL. Test Solution Measure 20 mL of the sample solution, add 30 mL of freshly boiled and cooled water, the turbidity of the solution should be slightly turbid or better.

(2) Arsenic : It should be no more than 4.0 ppm tested by Arsenic Limit Test.

(3) Lead : When 5.0 g of Sodium Methoxide is tested by Atomic Absorption Spectrophotometry or Inductively Coupled Plasma Emission Spectroscopy, its content should not be more than 5.0 ppm.

(4) Mercury : When Sodium Methoxide is tested by Mercury Limit Test, its content should not be more than 1.0 ppm.

(5) Sodium Carbonate : Proceed as directed under Assay (3) (Not more than 0.5% as Na₂CO₃).

(6) Sodium Hydroxide : Proceed as directed under Assay (4) (Not more than 2.0% as NaOH).

Assay (1) Weigh quickly and accurately about 0.5 g of Sodium Methoxide, using a titration flask for Karl Fischer method, immediately add 10 mL of salicylic acid methanol solution, stopper tightly, dissolve, cool, and proceed as directed un (1) Direct Titration in Water Determination (Karl Fischer Method). Perform a blank test on 10 mL of salicylic acid methanol solution in the same manner, and cal the sum (A) of the contents of sodium hydroxide and sodium carbonate as sodium hydroxide (NaOH) by the following formula :

$$A(\%) = \frac{(a - b) \times f \times 2.222}{\text{weight of the sample(g)} \times 1,000} \times 100$$

a = Volume (mL) of Karl Fischer solution consumed in this test,

b = Volume (mL) of Karl Fischer solution consumed in the blank test,

f = Weight (mg) of water corresponding to 1 mL of Karl Fischer solution.

Salicylic acid methanol solution : 10 g of salicylic acid is dissolved in 100 mL of methanol solution for Karl Fischer. Prepare prior to use.

(2) Weigh quickly and accurately about 2 g of Sodium Methoxide, using an Erlenmeyer flask with a ground-glass stopper, immediately and gently dissolve in about 50 mL of freshly boiled and cooled water. add 10 mL of barium chloride solution (3→25), stopper, allow to stand for 5 minutes, and titrate with 1 N hydrochloric acid (indicator : 2 drops of phenolphthalein solution). Calculate the sum (B) of the contents of sodium methoxide and sodium hydroxide as sodium me(CH_3ONa) by the following formula:

$$B(\%) = \frac{0.054 \times \text{consumption of 1N hydrochloric acid(mL)}}{\text{weight of the sample(g)}} \times 100$$

(3) Add 1 mL of 1N hydrochloric acid to the solution after titration in (2) above, boil gently for about 5 minutes. cool, and titrate the excess acid with 0.1N sodium hydroxide. Calculate the content (C) of sodium carbonate (Na_2CO_3) by the following formula

$$C(\%) = \frac{0.053[1-\text{consumption of 0.1N sodium hydroxide(mL)}] \times 0.1}{\text{weight of the sample(g)}} \times 100$$

(4) Calculate the content (D) of sodium hydroxide (NaOH) by the following formula

$$D(\%) = A - (C \times 0.377)$$

(5) Calculate the content (E) of sodium methoxide (CH_3ONa) by the following formula

$$E(\%) = B - (D \times 1.350)$$

Storage Standards of Sodium Methoxide

Store in a hermetic container.

Sodium Molybdate

Chemical Formula: $\text{Na}_2\text{MnO}_4 \cdot 2\text{H}_2\text{O}$

Molecular Weight: 241.95

CAS No.: 7631-95-0

Compositional Specifications of Sodium Molybdate

Content Sodium Molybdate should contain more than 99.0% of Sodium Molybdate($\text{Na}_2\text{MnO}_4 \cdot 2\text{H}_2\text{O}$).

Description Sodium Molybdate occurs as colorless~ white crystals or crystalline powder.

Identification

(1) When Sodium Molybdate is tested by the test for Flame Coloring Test. It appears yellow color.

(2) When Sodium Phosphate(Dibasic) is added to nitric acid acidic solution of Sodium Molybdate, yellow color precipitates are formed. When ammonia solution is added, the precipitates dissolve.

Purity (1) pH : pH of Sodium Molybdate solution(1→20) should not be more than 10.0.

(2) Clarity and Color of Solution : Weigh 1.0 g of Sodium Molybdate, add 20 mL of water, and dissolve it. The turbidity of the solution should not be more than almost clear.

(3) Ammonium : Approximately 1.0 g of Sodium Molybdate is precisely weighed and transferred into a distillation flask. 140 mL of water and 2 g of magnesium oxide is added and a distilling plant is attached to the flask. Add 20 mL of boric acid solution(1→200) as solution for absorption to 100 mL flask. Immerse the end of the distilling plant condenser to solution for absorption and adjust the temperature for heating to flow by 5~7 mL per minute so that the distilled solution is made to 60 mL. Wash the end of the condenser with a little of water and add water to make to 100 mL. This solution is used as test solution. Separately, a reference solution, 1.0 mL of ammonium standard solution(1 mL of this solution contains 0.01 mL of ammonium) is taken into a flask for distilling. And 60 mL of distilled solution is made by the same method of test solution. Wash the end of the condenser with a little of water and add water to make to 100 mL. This solution is used as reference solution. Each 30 mL of test solution and 30 mL of reference solution is separately taken into Nessler tube and add 6 mL of phenol-sodium nitroprusside solution. After shaking it to mix, add 4 mL of sodium hypochlorite•sodium hydroxide solution and water to make to 50 mL and shake it. And then allow the solution to stand for 60 minutes. The color of test solution should not be more intense than that of reference solution. (not more than 0.001%).

Reagent

Phenol-sodium nitroprusside solution : Add water to 5 g of phenol and 25 mg of sodium nitroprusside to make to 500 mL. The solution should be stored in a cold dark place.

Sodium hypochlorite•sodium hydroxide solution : Add water to 1.05 g of sodium hypochlorite and 15 g of sodium hydroxide to make to 1000 mL. The solution is prepared before use.

- (4) Chloride : When 1.0 g of Sodium Molybdate is dissolved in 10 mL of dilute nitric acid by heating, which is tested by Chloride Limit Test, its content should not be more than the amount that corresponds to 0.14 mL of 0.01 N hydrochloric acid.
- (5) Nitrate : Dissolve 1.0 g of Sodium Molybdate in 10 mL of water. When adding 0.05 mL of Indigo Carmine and 10 mL of Sulfuric acid, the blue color appears. This blue color should not disappear completely in 5 minutes (not more than 0.003%).
- (6) Sulfate : Dissolve 1.0 g of Sodium Molybdate in 5 mL of hot water. Add 5 mL of nitric acid to evaporate to dryness in water bath. After adding 1 mL of hydrochloric acid(1→4) and 10 mL of water to precipitate, add water to make to 50 mL. Filtered solution is used as test solution. When it is tested by Sulfate Limit Test, its content should not be more than the amount that corresponds to 0.1 mL of 0.01 N sulfuric acid.
- (7) Phosphate : 2.5 g of Sodium Molybdate is taken into beaker of polyethylene material(PE). Dissolve it in 70 mL of water and adjust pH 4~5 with hydrochloric acid(1→10). And then add 2 mL of bromine solution and again adjust pH 1.7~1.9 with hydrochloric acid(1→10). Transfer this solution into glass beaker and heat it until it starts to boil. After cooling at about 20 °C, add water to make to 90 mL and transfer it into a separatory funnel. Add 10 mL of hydrochloric acid and 20 mL of ether and shake strongly it to mix for 3 minutes. Take water layer and it is used as A solution. Wash ether layer with each 10 mL of hydrochloric acid 4 times. Add 0.2 mL of tin chloride solution(This solution is made with 2 g of tin chloride by adding hydrochloric acid to make to 100 mL) and shake it to mix for 30 seconds. And then add 25 mL of ether to this solution. The color of this solution should not be more intense than that of reference solution. Separately, 2.5 g of Sodium Molybdate is taken into beaker of polyethylene material(PE). Dissolve it in 1 mL of phosphate standard solution(0.01 mg/mL) and 10 mL of silicate standard solution(0.01 mg/mL) and 60 mL of water adjust pH 4~5 with hydrochloric acid(1→10). And then add 2 mL of bromine solution and again adjust pH 1.7~1.9 with hydrochloric acid(1→10). Transfer this solution into glass beaker and heat it until it starts to boil. After cooling at about 20 °C, add water to make to 90 mL and transfer it into a separatory funnel. Add 10 mL of hydrochloric acid and 20 mL of ether and shake strongly it to mix for 3 minutes. Take water layer and it is used as B solution. Wash ether layer with each 10 mL of hydrochloric acid 4 times. Add 0.2 mL of tin chloride solution(This solution is made with 2 g of tin chloride by adding hydrochloric acid to make to 100 mL) and shake it to mix for 30 seconds. And then add 25 mL of ether to this solution. This solution is used as reference solution (not more than 0.0005%).
- (8) Silicate : Add water to A solution of purity (7) to make to 100 mL. Transfer it into 200 mL separatory funnel. After adding 10 mL of hydrochloric acid and 50 mL of n-butanol, shake strongly it to mix for 5 minutes. Discard water layer and wash n-butanol with each 10mL of hydrochloric acid(1→10) 4 times. Add 0.5 mL of tin chloride of purity (7) to n-butanol layer for 30 minutes and shake it to mix. And then add n-butanol to make to 50 mL solution. The color of this solution should not be more intense than that of reference solution. Separately, add water to B solution of purity (7) to make to 100 mL.

Transfer it into 200 mL separatory funnel. After adding 10 mL of hydrochloric acid and 50 mL of n-butanol, shake strongly it to mix for 5 minutes. Discard water layer and wash n-butanol with each 10mL of hydrochloric acid(1→10) 4 times. Add 0.5 mL of tin chloride of purity (7) to n-butanol layer for 30 minutes and shake it to mix. And then add n-butanol to make to 50 mL solution. This blue solution is used as reference solution (not more than 0.005%).

(9) Lead : When 5.0 g of Sodium Molybdate is tested by Atomic Absorption Spectrophotometry or Inductively Coupled Plasma Emission Spectroscopy, its content should not be more than 2.0 ppm.

(10) Iron : Add water to 0.4 g of Sodium Molybdate to make 40 mL solution. And then add 5 mL of 10% Sodium hydroxide solution and boil it for 5 minutes. After cooling it, add 30 mL of 10% tartaric acid solution, transfer it into a separatory funnel. Add 20mL of hydroxylamine hydrochloride•ammonium perchlorate and 3 mL of ammonia water(2→5). After adjusting pH to pH 4, add 2 mL of 0.2% *o*-phenanthroline solution. Keep it at 20~35°C for 15 minutes and extract it by shaking strongly it with 10 mL of each chloroform 2 times for 30 seconds. Collect the chloroform layer and add chloroform to make to 25 mL. The color of this solution should not be more intense than that of reference solution. Separately, add water to 0.8 mL of Iron standard solution(0.01 mg/mL) to make 40 mL solution. And then add 5 mL of 10% Sodium hydroxide solution and boil it for 5 minutes. After cooling it, add 30 mL of 10% tartaric acid solution, transfer it into a separatory funnel. Add 20mL of hydroxylamine hydrochloride•ammonium perchlorate and 3 mL of ammonia water(2→5). After adjusting pH to pH 4, add 2 mL of 0.2% *o*-phenanthroline solution. Keep it at 20~35°C for 15 minutes and extract it by shaking strongly it with 10 mL of each chloroform 2 times for 30 seconds. Collect the chloroform layer and add chloroform to make to 25 mL. This dark reddish brown solution is used as reference solution (not more than 0.002%).

Reagent

Hydroxylamine hydrochloride•ammonium perchlorate solution : Add water to 25 g of hydroxylamine hydrochloride and 4.3 mL of 60% perchlorate solution and 200 mL of water and 46 mL of ammonia water. Adjust pH to pH 4 and add water to make to 500 mL.

Assay 0.6 g of Sodium Molybdate is precisely weighed and dissolved in 50 mL of water. After adding 2 mL of acetic acid(1→3) and water to make to 200 mL, heat it until it starts to boil. Then boil it with lead acetate solution for 5 minutes and keep it to precipitate it. After filtering it, wash it until reaction of lead ion is disappeared. After ashing it at 560~625°C, weigh of lead molybdate.

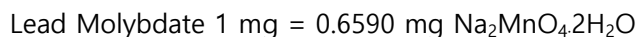

Reagent

Lead acetate solution : After adding water to 1.5 g of lead acetate to make to 20 mL, add 5 drops of acetic acid.

Sodium Nitrate

Chemical Formula: NaNO_3

Molecular Weight: 85.00

INS No.: 251

Synonyms: Chile saltpetre; Cubic or soda nitre

CAS No.: 7631-99-4

Compositional Specifications of Sodium Nitrate

Content Sodium Nitrate, when calculated on the dried basis, should contain not less than 99.0% of sodium nitrate (NaNO_3).

Description Sodium Nitrate occurs as colorless crystals or as a white crystalline powder. It is odorless and has a slightly salty taste.

Identification Sodium Nitrate responds to the tests for Sodium Salt and Nitrate in Identification.

Purity (1) Clarity and Color of Solution : Proceed as directed under Purity (1) for [Potassium Nitrate].

(2) Arsenic : It should be no more than 4.0 ppm tested by Arsenic Limit Test.

(3) Lead : Accurately weigh 5.0 g of Sodium Nitrate into a 150 mL beaker, add 30 mL of water. Add hydrochloric acid in small portion to the solution until the solid is dissolved thoroughly and add 1 mL of hydrochloric acid. Heat this solution for approximately 5 minutes and cool down. Add water to bring the total volume to 100 mL. Add sodium hydroxide solution(1→4) or hydrochloric acid(1→4) so that pH becomes 2 ~ 4. Transfer this solution into 250 mL separatory funnel, where water is added to make 200 mL. Then add 2 mL of 2% APDC solution and shake to mix. Extract the solution 2 times with 20 mL each of chloroform, which is evaporated to dryness in a water bath. Add 3 mL of nitric acid to the residue and heat it until nearly evaporated. To this solution, add 0.5 mL of nitric acid and 10 mL of water, concentrate it until the final solution becomes 3~5 mL, and add water to make 10 mL, test solution. When the test solution is tested by Atomic Absorption Spectrophotometry or Inductively Coupled Plasma Emission Spectroscopy, its content should not be more than 2.0 ppm.

2% APDC Solution : 2.0 g of Ammonium Pyrolidine Dithiocarbamate is dissolved in water to make 100 mL. Filter it when using.

(4) Mercury : When Sodium Nitrate is tested by Mercury Limit Test, its content should not be more than 1.0 ppm.

(5) Nitrite : Accurately weigh about 1 g of Sodium Nitrate, dissolve in water to make 100 mL. Take 20mL of this solution into a 100mL volumetric flask and add water to make 80 mL and add 10mL of sulfanilamide solution and mix. After 3 min add 1mL of coupling reagent, dilute to mark with water, mix and let stand for 15min. Measure the absorbance of the solution against water of 540nm using 10mm cuvettes. Read on the standard curve the amount of nitrite corresponding to the actual absorbance. Then the content should not be more than 30 ppm.

$$\text{Nitrite(ppm)} = \frac{A \times 5}{W}$$

A : content of nitrite calculated from calibration curve (μg)

W : weight of sample(g)

Calibration Curve Preparation : Pipette into 100mL volumetric flasks 0,5,10,20 and 50mL of nitrite standard (corresponding to 0,2,5,10 and 25 μg of nitrite) and dilute to about 80mL with water. Add to each of the flask. 10mL of sulfanilamide solution and mix. After 3 min add 1mL of coupling reagent, dilute to mark with water, mix and let stand for 15 min. Measure the absorbance of the solution against water at 540 nm using 10mm cuvettes. Draw a standard curve with absorbance as function of amount of nitrite.

Sulfanilamide solution : Dissolve 2 g of sulfanilamide in 1000 mL dilute hydrochloric acid TS

Coupling reagent : Dissolve 0.2 g of N-1-naphthylethylenediamine dihydrochloride in water and dilute to make 100 mL.

Standard solution : Accurately weigh 0.75 g of sodium nitrite and dissolve in water and dilute to make 1000 mL. Dilute 10 mL of this solution to 100 mL with water. Finally dilute 10 mL of this preparation to 1000 mL with water.

(6) Chloride : When 0.1 g of Sodium Nitrate is tested by Chloride Limit Test, its content should not be more than the amount that corresponds to 0.6 mL of 0.01 N hydrochloric acid.

Loss on Drying When Sodium Nitrate is dried for 4 hours at 105°C, the loss should not be more than 1%.

Assay Proceed as directed under Assay for [Potassium Nitrate].

1 mL of 0.1 N sulfuric acid = 8.500 mg of NaNO_3 .

Sodium Nitrite

Chemical Formula: NaNO_2

INS No.: 250

Molecular Weight: 69.00

CAS No.: 7632-00-0

Compositional Specifications of Sodium Nitrite

Content Sodium Nitrite, when calculated on the dried basis, should contain not less than 97.0% of sodium nitrite (NaNO_2).

Description Sodium Nitrite occurs as white to light yellow crystalline powder or granular or rod-shaped lumps.

Identification Sodium Nitrite responds to the tests for Sodium Salt and Nitrite in Identification.

Purity (1) Clarity and Color of Solution : When 1 g of Sodium Nitrite is dissolved in 20 mL of water, the solution should not be more than almost clear.

(2) Chloride : 1 g of Sodium Nitrite is dissolved in water to make 500 mL. Take 10 mL of this solution, add 3 mL of diluted acetic acid. and warm gradually. After the gas is no longer evolved, add 6 mL of diluted nitric acid. When Chloride Limit Test limit test is carried out with this test solution, its content should not be more than the amount that corresponds to 0.4 mL of 0.01 N hydrochloric acid.

(3) Sulfate: 1 g of Sodium Nitrite is dissolved in water to make 100 mL. Take 10 mL of this solution, add 1 mL of hydrochloric acid. 1 mL of diluted hydrochloric acid and 20 mL water is added to the residue, Test Solution. When the test solution is tested by Sulfate Limit Test, the content should not be more than the amount that corresponds to 0.5 mL of 0.01 N sulfuric acid.

(4) Arsenic : It should be no more than 4.0 ppm tested by Arsenic Limit Test.

(5) Lead : Sodium Nitrite is tested by purity (2) for 「Sodium Metaphosphate」(not more than 2.0 ppm).

(6) Mercury : When Sodium Nitrite is tested by Mercury Limit Test, its content should not be more than 1.0 ppm.

Loss on Drying When Sodium Nitrite is dried for 5 hours at 100°C, the weight loss should not be more than 3%.

Assay 1 g of Sodium Nitrite, previously dried and accurately weighed, is dissolved in water to make 100 mL, and use this solution as solution A. Weigh exactly 40 mL of 0.1 N potassium permanganate, transfer into an erlenmeyer flask, and add 100 mL of water and 5 mL of sulfuric acid. Take 10 mL of solution A while keeping the tip of the pipette below the surface of the liquid in an erlenmeyer flask. Allow to stand for 5 minutes, add 25 mL of 0.1 N oxalic acid, exactly measured, warm to about 80°C, and titrate the excess oxalic acid with 0.1 N potassium permanganate while hot. Perform a blank test in the same manner.

1 mL of 0.1 N potassium permanganate = 3.450 mg of NaNO_2

Sodium Oleate

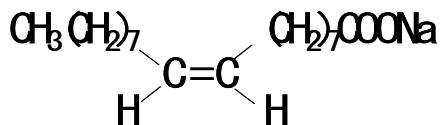

Chemical Formula: $\text{C}_{18}\text{H}_{33}\text{NaO}_2$

Molecular Weight: 304.45

INS No.: 470(ii)

Synonyms: Sodium salts of oleic acid

CAS No.: 143-19-1

Description Sodium Oleate occurs as a white ~ yellow powder or a pale yellowish brown chunk or lump with characteristic odor and taste.

Identification (1) Thoroughly, mix 50 mL of Sodium Oleate (2->50) in an aqueous solution with 5mL of sulfuric acid (1->2) and filter this mixture with pre-water wetted filter paper. Continue wash the residue until there is no acid indicated by the methyl orange indicator. Filter the remaining residue with a dry filter paper. Place 2-3 drops of the filtrate and 1mL of sulfuric acid in a small test tube. Brown lining is expected to show on the contact surface of both. Dissolve 1-3 drops of the filtrate with 3-4mL of acetic acid (1->4) and add 1 drop of chromium trioxide acetate solution (1->10) then slowly add 10~30 drops of sulfuric acid which would show a dark purple color.

(2) The residue on ignition of Sodium Oleate responds to the test for Sodium Salt.

Purity (1) Clarity and Color of Solution: When 0.5g of Sodium Oleate is dissolved in 20mL of water, the solution should be almost clear.

(2) Free Alkali: Precisely weigh 5g of Sodium Oleate powder and add 100mL of neutralized alcohol then heat this solution to dissolve. Filter insoluble substances and rinse the residue until it has no color with 40°C neutralized alcohol. Collect the filtrate and rinse solution. After cooling, titrate the solution with 0.05N sulfuric acid and its consumed amount is regarded as the a mL. Rinse the residue 5 times with 10mL of hot water and collect all the solutions in a beaker. Add 3 drops of Bromophenol blue solution and titrate it with 0.05N sulfuric acid. The consumed amount of 0.05N sulfuric acid is regarded as the b mL. When calculated by the following equation, the content of free alkali should not be more than 0.5%

$$\text{Content of Free Alkali (\%)} = [0.0040 * a + 0.0053 * b] / \text{Weight of sample (g)} * 100$$

(3) Arsenic: It should be no more than 4.0 ppm tested by Arsenic Limit Test.

(4) Lead : Sodium Oleate is tested by Purity (2) for 「Sodium Metaphosphate」(not more than 2.0 ppm).

Residue on Ignition Residue on ignition of Sodium Oleate should be within a range of 22 ~ 25%.

Sodium Pantothenate

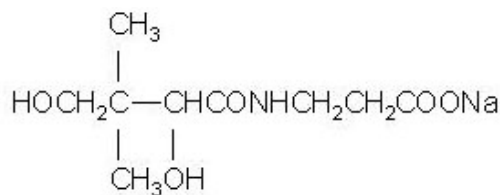

Chemical Formula: C₉H₁₆O₅NNa

Molecular Weight: 241.22

CAS No.: 867-81-2

Compositional Specifications of Sodium Pantothenate

Content Sodium Pantothenate, when calculated on the dried basis, should contain within a range of 5.6~6.0% of nitrogen (N = 14.01) and 9.3~9.7% of sodium (Na = 22.94).

Description Sodium Pantothenate is odorless white crystalline powder or powder with slightly sour taste.

Identification (1) Proceed as directed under Identification (1) and (2) in 「Calcium Pantothenate」.

(2) Sodium Pantothenate solution (1→20) responds to the test for Sodium Salt in Identification.

Purity (1) pH : pH of Sodium Pantothenate solution (2→10) should be within a range of 9.0~10.0.

(2) Specific Rotation : Approximately 1.25 g of Sodium Pantothenate, previously dried for 24 hours in a vacuum desiccator (silica gel) and weighed, is dissolved in 25 mL of water. Optical rotation of Sodium Pantothenate should be within a range of $[\alpha]_D^{20} = +25 \sim +28.5^\circ$.

(3) Arsenic : It should be no more than 4.0 ppm tested by Arsenic Limit Test.

(4) Lead : Sodium Pantothenate is tested by Purity (2) for 「Sodium Metaphosphate」(not more than 2.0 ppm).

(5) Calcium : 1 g of Sodium Pantothenate is dissolved in 10 mL of water, where 0.5 mL of diluted acetic acid and 0.5 mL of ammonium oxalate solution are added, precipitate should not be formed.

(6) Alkaloid : Proceed as directed under Purity (5) in 「Calcium Pantothenate」.

Loss on Drying When Sodium Pantothenate is dried for 24 hours in a vacuum desiccator (silica gel), the weight loss should not be more than 5%.

Assay (1) Nitrogen : 50 mg of Sodium Pantothenate, precisely dried and accurately weighed, is proceeded as directed under Semi-micro Kjeldahl Method in Nitrogen Determination Method.

(2) Sodium : Dissolve 0.6 g of Sodium Pantothenate, precisely dried and accurately weighed, in 50 mL of acetic acid. It is then titrated with 0.1 N perchloric acid (indicator : 1 mL Crystal violet glacial acetic acid solution). End point is where the violet color of the solution becomes through blue then to green. Separately, a blank test is carried out by the same procedure.

1 mL of 0.1 N Perchloric acid = 2.30 mg Na

Sodium Phosphate, Dibasic

Chemical Formula: Na₂HPO₄

Molecular Weight: 141.96

INS No.: 339(ii)

Synonyms: Disodium phosphate; Disodium acid phosphate

CAS No.: 7758-79-4

Definition Sodium Phosphate, Dibasic has two forms, crystalline (2 ~ 12 hydrated) and anhydrous, which is named dibasic sodium phosphate (crystalline) and dibasic sodium phosphate (anhydrous), respectively.

Compositional Specifications of Sodium Phosphate, Dibasic

Content Sodium Phosphate, Dibasic, when calculated on the dried basis, should contain not less than 98.0% of dibasic sodium phosphate (Na₂HPO₄ = 141.96).

Description Crystalline form of Sodium Phosphate, Dibasic is colorless ~ white crystallite or crystalline lump. Anhydrous form is white powder or granule.

Identification Sodium Phosphate, Dibasic solution (1→20) responds to test of sodium salts(A), (B) and Phosphate in Identification.

Purity Crystalline form is dried for 3 hours at 40°C and 4 hours at 120°C prior to test.

- (1) Water Insoluble substances : Sodium Phosphate, Dibasic is tested by Purity (1) [Sodium Phosphate, Tribasic] and the content of water insoluble substances should not be more than 0.2%.
- (2) pH : pH of Sodium Phosphate, Dibasic solution (1→100) is measured using a glass electrode and should be within a range of 9.0 ~ 9.6.
- (3) Arsenic : It should be no more than 4.0 ppm tested by Arsenic Limit Test.
- (4) Lead : Sodium Phosphate, Dibasic is precisely weighed and is tested by purity (2) for 「Sodium Metaphosphate」, its content should not be more than 4.0 ppm.
- (5) Cadmium : Sodium Phosphate, Dibasic is precisely weighed and is tested by purity (3) for 「Sodium Metaphosphate」, its content should not be more than 1.0 ppm.
- (6) Mercury : When Sodium Phosphate, Dibasic is tested by Mercury Limit Test, its content should not be more than 1.0 ppm.
- (7) Fluoride : 1 g of Sodium Phosphate, Dibasic is precisely weighed and is tested by purity (8) for 「Calcium Citrate」, its content should not be more than 10 ppm.

Loss on Drying When crystalline form of Sodium Phosphate, Dibasic is dried for 3 hours at 40°C and further dried for 4 hours at 120°C, the loss should not be more than 61.0%. When anhydrous form is dried for 4 hours at 120°C, the loss should not be more than 2%.

Assay Dissolve 3 g of Sodium Phosphate, Dibasic, previously dried and accurately weighed, in 50 mL of

water. The solution is kept at 15°C and titrated with 1 N hydrochloric acid (indicator : 3 ~ 4 drops of Methyl Orange.Xylene Cyanol FF solution).

1 mL of 1 N hydrochloric acid = 141.96 mg Na₂HPO₄

Sodium Phosphate, Monobasic

Chemical Formula: $\text{NaH}_2\text{PO}_4 \cdot n\text{H}_2\text{O}$ (n = 2, 1, or 0)

Molecular Weight: 119.98(anhydrous)

INS No.: 339(i)

Synonyms: Sodium dihydrogen phosphate;
Monosodium monophosphate; Sodium acid
phosphate

CAS No.: 7758-80-7

Definition Sodium Phosphate, Monobasic has two forms, crystalline (hydrate, dihydrate) and anhydrous, which is named monobasic sodium phosphate (crystalline) and monobasic sodium phosphate (anhydrous).

Compositional Specifications of Sodium Phosphate, Monobasic

Content Sodium Phosphate, Monobasic should contain not less than 97.0% of monobasic sodium phosphate ($\text{NaH}_2\text{PO}_4 = 119.98$), when calculated on the dried basis,

Description Crystalline form of Monobasic Sodium Phosphate is colorless ~ white crystallite or crystalline powder. Anhydrous form of Monobasic Sodium Phosphate is white powder or granule.

Identification Sodium Phosphate, Monobasic solution (1→20) responds to test of sodium salt and Phosphate in Identification.

Purity Crystalline form is dried for 16 hours at 40°C and 4 hours at 120°C prior to test.

- (1) pH : pH of Sodium Phosphate, Monobasic solution (1→100) should be within a range of 4.2 ~ 4.6 by glass electrode method.
- (2) Arsenic : It should be no more than 4.0 ppm tested by Arsenic Limit Test.
- (3) Lead : Sodium Phosphate, Monobasic is precisely weighed and is tested by purity (2) for 「Sodium Metaphosphate」, its content should not be more than 4.0 ppm.
- (4) Cadmium : Sodium Phosphate, Monobasic is precisely weighed and is tested by purity (3) for 「Sodium Metaphosphate」, its content should not be more than 1.0 ppm.
- (5) Mercury : When Sodium Phosphate, Monobasic is tested by Mercury Limit Test, its content should not be more than 1.0 ppm.
- (6) Fluoride : 1 g of Sodium Phosphate, Monobasic is precisely weighed and is tested by purity (8) for 「Calcium Citrate」, its content should not be more than 10 ppm.
- (7) Free Acid and Sodium Phosphate, Dibasic : 2 g of Sodium Phosphate, Monobasic is dissolved in 40 mL of water. When the solution is neutralized with 1 N sodium hydroxide solution or 1 N sulfuric acid, the consumed amount should not be more than 0.3 mL. (Indicator : Methyl Orange Indicator Solution).

Loss on Drying Sodium Phosphate, Monobasic is dried for 1 hour at 60°C and further dried for 4 hours at 105°. Loss on drying should be 2.0%, 15.0%, and 25.0% or less for anhydrous, 1 hydrated, and 2

hydrated form, respectively.

Assay Dissolve 3 g of Sodium Phosphate, Monobasic, previously dried and accurately weighed, in 30 mL of water. 5g of sodium chloride is added, which is dissolved by shaking. While the solution is kept at 15°C, it is titrated with 1 N sodium hydroxide solution (Indicator : 3 ~ 4 drops of thymol blue solution)

1 mL of 1 N sodium hydroxide solution = 119.98 mg NaH_2PO_4

Sodium Phosphate, Tribasic

Chemical Formula: Na_3PO_4

Molecular Weight: 163.94

INS No.: 339(iii)

Synonyms: Trisodium phosphate

CAS No.: 7601-54-9

Definition Tribasic Sodium Phosphate has two forms, crystalline and anhydrous, which is named tribasic sodium phosphate (crystalline) and tribasic sodium phosphate (anhydrous), respectively.

Compositional Specifications of Sodium Phosphate, Tribasic

Content Tribasic Sodium Phosphate, when calculated on the dried basis, should contain within a range of 97.0 ~ 103.0% of tribasic sodium phosphate ($\text{Na}_3\text{PO}_4 = 163.94$).

Description Crystalline form of Tribasic Sodium Phosphate is colorless ~ white crystallite or crystalline powder. Anhydrous form of Tribasic Sodium Phosphate is white powder or granule.

Identification Tribasic Sodium Phosphate solution (1→20) responds to test of Sodium Salt reactions (A), (B) and Phosphate reaction in Identification.

Purity Crystalline form is dried for 2 hours at 120°C and 5 hours at 200°C prior to the following tests.

- (1) Water Insoluble Substances : 10 g of Tribasic Sodium Phosphate is tested according to Purity (1) for 「Sodium Acid Pyrophosphate」, the content should not be more than 0.2%.
- (2) pH : pH of an aqueous solution (1→100) of Tribasic Sodium Phosphate is measured using a glass electrode method. Its should be within a range of 11.5 ~ 12.5.
- (3) Arsenic : It should be no more than 4.0 ppm tested by Arsenic Limit Test.
- (4) Lead : Tribasic Sodium Phosphate is precisely weighed and is tested by purity (2) for 「Sodium Metaphosphate」, its content should not be more than 4.0 ppm.
- (5) Cadmium : Tribasic Sodium Phosphate is precisely weighed and is tested by purity (3) for 「Sodium Metaphosphate」, its content should not be more than 1.0 ppm.
- (6) Mercury : When Tribasic Sodium Phosphate is tested by Mercury Limit Test, its content should not be more than 1.0 ppm.
- (7) Fluoride : 1 g of Tribasic Sodium Phosphate is precisely weighed and is tested by purity (8) for 「Calcium Citrate」, its content should not be more than 10 ppm.

Loss on Drying When crystalline form of Tribasic Sodium Phosphate is dried for 2 hours at 120°C and further dried for 5 hours at 200°C, the loss should not be more than 58.0%. When anhydrous form is dried for 5 hours at 200°C, the loss should not be more than 5%.

Assay Dissolve 2 g of Tribasic Sodium Phosphate, previously dried and accurately weighed, in 50 mL of water. The solution is kept at 15°C and titrated with 1 N hydrochloric acid (Indicator : 3 ~ 4 drops of Methyl Orange.Xylene Cyanol FF solution).

1 mL of 1 N hydrochloric acid = 81.97 mg Na_3PO_4

Sodium Polyacrylate

Compositional Specifications of Sodium Polyacrylate

Description Sodium Polyacrylate occurs as a white powder. It is odorless.

Identification To 0.2 g of Sodium Polyacrylate, add 100 mL of water by shaking, Test Solution. This solution is tested as follows.

- (1) To 10 mL of Test Solution, add 1 mL of calcium chloride solution, and shake. A white precipitate is formed immediately.
- (2) To 10 mL of Test Solution, add 1 mL of magnesium sulfate solution, and shake. A white precipitate is formed.
- (3) To 10 mL of Test Solution, add 1 mL of cobalt chloride solution (1→25) and then add 2 ~ 3 drops of ammonium chloride solution. Pale red precipitate is generated. When the precipitate is dried, it turns violet.
- (4) The residue on ignition of Sodium Polyacrylate responds to the test for Sodium Salt in Identification.

Purity (1) Free Alkali : To 0.2 g of Sodium Polyacrylate, add 60 mL of water and dissolve while shaking well, add 3 mL of calcium chloride solution and heat in a water bath for about 20 minutes, cool, and filter. Wash the residue on the filter paper with water, combine the filtrate and the washings, and add water to make 100 mL. Use this solution as solution A. Measure 50 mL of solution A, and add 2 drops of phenolphthalein solution. No pink color develops.

(2) Sulfate : When 1 mL of dilute hydrochloric acid is added to 20 mL of Purity in (1), which is tested by Sulfate Limit Test, its content should not be more than the amount that corresponds to 0.4 mL of 0.01 N sulfuric acid.

(3) Arsenic : It should be no more than 4.0 ppm tested by Arsenic Limit Test.

(4) Lead : Sodium Polyacrylate is tested by Purity (2) for Sodium Metaphosphate (not more than 2.0 ppm).

(5) Residual Monomers : Accurately weigh about 1 g of Sodium Polyacrylate, transfer into a 300 mL iodine bottle, add 100 mL of water, and dissolve by allowing to stand for about 24 hours while shaking occasionally. Add 10 mL of potassium bromate potassium bromide solution, accurately measured, shake well, add quickly about 10 mL of hydrochloric acid, immediately stopper tightly, shake well, transfer about 20 mL of potassium iodide solution into the top of the iodine bottle, and allow to stand in a dark place for 20 minutes. Loosen the stopper to allow the potassium iodide solution to flow into the solution, immediately stopper tightly, shake well, and titrate with 0.1 N sodium thiosulfate (indicator : starch solution). Perform a blank test in the same manner, and calculate the content by the following formula. It should not be more than 1%.

$$\text{Content of residual monomer(\%)} = \frac{0.0047 \times (a - b)}{\text{Weight of the sample(g)}} \times 100$$

a = volume (mL) of 0.1 N sodium thiosulfate consumed in the blank test,

b = volume (mL) of 0.1 N sodium thiosulfate consumed in this test.

(6) Low Molecular Weight Polymers : Accurately weigh about 2 g of Sodium Polyacrylate, add 200 mL of water, and dissolve by setting it aside for 24 hours while shaking occasionally. Add 50 mL of hydrochloric acid while stirring, warm in a water bath at 40°C for 30 minutes while stirring, and allow to stand for 24 hours. Filter the solution, add 1 drop of phenolphthalein solution to the filtrate, add sodium hydroxide solution (2→5) until the color of the filtrate changes to a slightly pink color, and add drop wise diluted hydrochloric acid (1→30) until the pink color disappears. Add 200 mL of water, add drop wise 25 mL of calcium chloride solution while stirring, and warm in a water bath at about 40°C for 30 minutes while stirring. Filter this solution with suction through the above glass filter, wash the residue 3 times with about 10 mL of water each time, dry at 105°C for 3 hours, allow to cool in a desiccator, Accurately weigh, and calculate the content by the following formula. It should not be more than 5%.

$$\text{Content of low molecular weight polymers(\%)} = \frac{\text{Weight of the residue(g)} \times 1.0324}{\text{Weight of the sample(g)}} \times 100$$

Loss on Drying When Sodium Polyacrylate is dried for 4 hours at 105°C, the weight loss should not be more than 10%.

Residue on Ignition Sodium Polyacrylate is dried for 4 hours at 105°C. When thermogravimetric analysis is done with 1 g of Sodium Polyacrylate, the amount of residues should not be more than 76%

Sodium Polyphosphate

INS No.: 451(i)

Synonyms: Sodium tripolyphosphate, Pentasodium
triphosphate

CAS No.: 7758-29-4
15091-98-2

Compositional Specifications of Sodium Polyphosphate

Content Sodium Polyphosphate, when calculated on the dried basis, should contain within a range of the equivalent of 53.0 ~ 80.0% of phosphorus pentoxide ($P_2O_5 = 141.95$).

Description Sodium Polyphosphate occurs as a white powder or as colorless to white glassy fragments or lumps.

Identification (1) Dissolve 0.1 g of Sodium Polyphosphate solution in 10 mL of water, add diluted acetic acid to make weakly acidic, and add 1 mL of silver nitrate solution. A white precipitate is formed.

(2) Sodium Polyphosphate solution (1→20) responds to the test for Sodium Salt in Identification.

Purity (1) Clarity and Color of Solution : Weigh 1 g of powdered Sodium Polyphosphate, add 20 mL of water, heat, and dissolve. It should be colorless and have a very slightly turbid.

(2) Chloride : When 0.1 g of Sodium Polyphosphate is tested by Chloride Limit Test, its content should not be more than the amount that corresponds to 0.6 mL of 0.01 N hydrochloric acid.

(3) Sulfate : Weigh 0.5 g of powdered Sodium Polyphosphate, add 30 mL of water and 2 mL of diluted hydrochloric acid, dissolve while boiling for 1 minute, cool. This solution is tested by Sulfate Limit Test, its content should not be more than the amount that corresponds to 0.5 mL of 0.01 N sulfuric acid.

(4) Orthophosphate : Weigh 1 g of powdered Sodium Polyphosphate, and add 2 ~ 3 drops of silver nitrate solution. No brilliant yellow color develops.

(5) Arsenic : It should be no more than 2.0 ppm tested by Arsenic Limit Test.

(6) Lead : Sodium Polyphosphate is tested by purity (2) for 「Sodium Metaphosphate」(not more than 4.0 ppm).

(7) Cadmium : Sodium Polyphosphate is tested by purity (3) for 「Sodium Metaphosphate」(not more than 1.0 ppm).

(8) Mercury : When Sodium Polyphosphate is tested by Mercury Limit Test, its content should not be more than 1.0 ppm.

(9) Fluoride : 1 g of Sodium Polyphosphate is tested by purity (8) for 「Calcium Citrate」(not more than 10 ppm).

Loss on Drying When Sodium Polyphosphate is dried for 4 hours at 110°C, the weight loss should not be more than 5%.

Assay Proceed as directed under Assay for 「Sodium Metaphosphate」.

Sodium Propionate

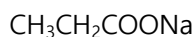

Chemical Formula: $\text{C}_3\text{H}_5\text{O}_2\text{Na}$

Molecular Weight: 96.06

INS No.: 281

Synonyms: Sodium propanoate

CAS No.: 137-40-6

Compositional Specifications of Sodium Propionate

Content Sodium Propionate, when calculated on the dried basis, should contain not less than 99.0% of sodium propionate ($\text{C}_3\text{H}_5\text{O}_2\text{Na}$).

Description Sodium Propionate occurs as white crystals, crystalline powder, or granules. It is odorless or has a slight, characteristic odor.

Identification (1) Proceed as directed under Identification (1) in 「Calcium Propionate」.

(2) Sodium Propionate responds to the test for Sodium Salt in Identification.

Purity (1) Clarity and Color of Solution : 1 g of Sodium Propionate, dissolved in 20 mL of water. This solution should be colorless and slightly turbid.

(2) Free Acid and Free Alkali : 2 g of Sodium Propionate is dissolved in 20 mL of freshly boiled and cooled water. When 2 drops of phenolphthalein solution and 0.3 mL of 0.1 N hydrochloric acid are added, it becomes colorless. When 0.6 mL of 0.1 N sodium hydroxide solution is added to the solution, it becomes red.

(3) Arsenic : It should be no more than 4.0 ppm tested by Arsenic Limit Test.

(4) Lead : When 5.0 g of Sodium Propionate is tested by Atomic Absorption Spectrophotometry or Inductively Coupled Plasma Emission Spectroscopy, its content should not be more than 5.0 ppm.

(5) Iron : When 5.0 g of Sodium Propionate is tested by Atomic Absorption Spectrophotometry or Inductively Coupled Plasma Emission Spectroscopy, its content should not be more than 50 ppm.

(6) Mercury : When Sodium Propionate is tested by Mercury Limit Test, its content should not be more than 1.0 ppm.

Loss on Drying When Sodium Propionate is dried for 1 hour at 105°C, the weight loss should not be more than 5%.

Assay Accurately weigh about 200 mg of Sodium Propionate, previously dried, dissolve in 50 mL of acetic acid for nonaqueous titration, and warm if necessary. Titrate with 0.1 N perchloric acid (indicator : 1 drop of crystal violet-acetic acid solution). Perform a blank test in the same manner, and make any necessary correction.

1 mL of 0.1 N perchloric acid = 9.606 mg of $\text{C}_3\text{H}_5\text{O}_2\text{Na}$

Sodium Pyrophosphate

Chemical Formula: $\text{Na}_4\text{P}_2\text{O}_7 \cdot n\text{H}_2\text{O}$ ($n = 10$ or 0)

Molecular Weight: 10hydrates 446.09

anhydrous 265.90

INS No.: 450(iii)

Synonyms: Tetrasodium pyrophosphate; Tetrasodium diphosphate; Tetrasodium phosphate

CAS No.: 7722-88-5

Definition Sodium Pyrophosphate occurs as crystals (decahydrate) called Sodium Pyrophosphate (crystal) and as anhydrous called Sodium Pyrophosphate (anhydrous).

Compositional Specifications of Sodium Pyrophosphate

Content Sodium Pyrophosphate, when calculated on the dried basis, should contain not less than 95.0% of sodium pyrophosphate ($\text{Na}_4\text{P}_2\text{O}_7 = 265.90$).

Description Sodium Pyrophosphate (crystal) occurs as colorless~white or white crystals or as a white crystalline powder. Sodium Pyrophosphate (anhydrous) occurs as white powder, granules or lumps.

Identification (1) 0.1 g of Sodium Pyrophosphate is dissolved in 10 mL of water, which is weakly acidified with dilute acetic acid. When silver nitrate solution is added to this solution, white precipitates are formed.

(2) Sodium Pyrophosphate solution (1→20) responds to test of Sodium Salt in Identification.

Purity Perform the test of Sodium Pyrophosphate, previously dried at 105°C for 4 hours

(1) Water Insoluble Substances : 10 g of Sodium Pyrophosphate is tested by Purity (1) for 「Acidic Sodium Pyrophosphate」, its content should not be more than 0.2%.

(2) pH : When Sodium Pyrophosphate solution(1→100) should be within a range of 9.9 ~ 10.7.

(3) Arsenic : It should be no more than 4.0 ppm tested by Arsenic Limit Test.

(4) Lead : Sodium Pyrophosphate is tested by purity (2) for 「Sodium Metaphosphate」(not more than 4.0 ppm).

(5) Cadmium : Sodium Pyrophosphate is tested by purity (3) for 「Sodium Metaphosphate」(not more than 1.0 ppm).

(6) Mercury : When Sodium Pyrophosphate is tested by Mercury Limit Test, its content should not be more than 1.0 ppm.

(7) Fluoride : 1 g of Sodium Pyrophosphate is precisely weighed and is tested by purity (8) for 「Calcium Citrate」(not more than 10 ppm).

Loss on Drying Sodium Pyrophosphate is dried for 4 hours at 105°C. It is then heat treated for 30 minutes at 550°C. The weight loss should not be more than 0.5% for anhydrous form and 38.0 ~ 42.0% for decahydrate form.

Assay After heat treatment, transfer approximately 500 mg of Sodium Pyrophosphate into a 400 mL beaker, and add 100 mL of water. pH of the solution is adjusted to 3.8 using a pH meter. 50 mL of zinc

sulfate solution (1→8) [125 g of $\text{ZnSO}_4 \cdot 7\text{H}_2\text{O}$ 125 g is dissolved in water to make 1,000 mL solution. pH is adjusted to 3.8] is mixed. After 2 minutes, Free acid is titrated with 0.1 N sodium hydroxide until pH become 3.8 again. However, after sodium hydroxide solution is added, the precipitated zinc hydroxide should be placed quietly to allow for melting again around the end point.

1 mL of 0.1 N sodium hydroxide solution = 13.30 mg $\text{Na}_4\text{P}_2\text{O}_7$

Sodium Saccharin

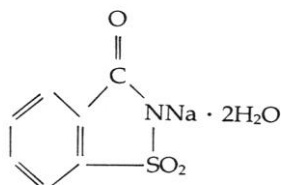

Chemical Formula: $C_7H_4O_3NSNa \cdot 2H_2O$

Molecular Weight: 241.21

INS No.: 954(iv)

Synonyms: Soluble saccharin

CAS No.: 6155-57-3

Compositional Specifications of Sodium Saccharin

Content Sodium Saccharin, when calculated on the dried basis, should contain within a range of 98.0 ~ 101.0% of soluble saccharin ($C_7H_4O_3NSNa = 205.17$).

Description Sodium Saccharin occurs as colorless to white crystals or crystalline powder. It has strong sweet taste in Sodium Saccharin solution.

Identification (1) Dissolve 0.5 g of Sodium Saccharin in 10 mL of water, add 1 mL of diluted hydrochloric acid, allow to stand for 1 hour, filter the white crystalline precipitate formed, wash the residue on the filter paper thoroughly with water, dry at 105°C for 2 hours, and measure the melting point. It should be within a range of 226 ~ 230°C.

(2) To 20 mg of Sodium Saccharin, add 40 mg of resorcinol and 10 drops of sulfuric acid, and heat gently until the color of the mixture changes to dark green. After cooling, dissolve in 10 mL of water and 10 mL of sodium hydroxide solution. The solution becomes to green fluorescence.

(3) Dissolve 0.1 g of Sodium Saccharin in 5 mL of sodium hydroxide solution, evaporate to dryness while gently heating. Careful to avoid being carbonized, and continue heating until the odor of ammonia no longer develops. After cooling, dissolve in about 20 mL of water, neutralize with diluted hydrochloric acid, filter. and then add 1 drop of ferric chloride solution to the filtrate. The color of this solution appears purple to reddish-purple.

(4) Sodium Saccharin solution (1→10) responds to the test for Sodium Salt in Identification.

Purity (1) Clarity and Color of Solution : When dissolve each 1 g of Sodium Saccharin, previously powdered, in 1.5 mL of water and 70 mL of 95% alcohol, respectively, both solutions should be colorless and clear.

(2) Free Acid and Free Alkali : Weigh 1 g of Sodium Saccharin, dissolve in 10 mL of freshly boiled and cooled water, and add 1 drop of phenolphthalein solution. The color of the solution should not become

to pink. When add 1 drop of 0.1 N sodium hydroxide again, the color of the solution should become to pink.

(3) Benzoate and Salicylate : Weigh 0.5 g of Sodium Saccharin, dissolve in 10 mL of water, and add 5 drops of acetic acid and 3 drops of ferric chloride solution. No precipitate is formed, and no purple to reddish-purple color develops.

(4) Arsenic : It should be no more than 4.0 ppm tested by Arsenic Limit Test.

(5) Lead : When 5.0 g of Sodium Saccharin is tested by Atomic Absorption Spectrophotometry or Inductively Coupled Plasma Emission Spectroscopy, its content should not be more than 1.0 ppm.

(6) o-Toluenesulfonamide : Weigh 40 g of Sodium Saccharin, dissolve in 200 mL of water, extract 3 times with 30 mL of ethyl acetate each time, combine all the ethyl acetate layers, wash with 30 mL of 25% sodium chloride solution, dehydrate to anhydrous sodium sulfate, and then evaporate the ethyl acetate. Dissolve the residue in 5 mL of solution of caffeine in ethyl acetate, Test Solution. Separately, measure 1.0 mL of a solution of o-toluenesulfonamide in ethyl acetate (1→1,000), remove the ethyl acetate while heating on a water bath, and dissolve the residue in 5 mL of a solution of caffeine in ethyl acetate (1→5,000), Standard Solution.

Procedure Perform Gas Chromatography on the test solution and the standard solution under the conditions given below. The ratio H/HS of the peak height of o-toluenesulfonamide (H) of the test solution to the peak height of caffeine (HS) does not more than the ratio H'/HS' of the peak height of o-toluenesulfonamide (H') of the standard solution to the peak height of caffeine (HS'). Specially, caffeine-ethyl acetate solution(1→5,000) is used as solution of internal standard.

Operation Conditions

- Column : Glass or stainless steel tube (length : 1 m, internal diameter: 3 ~ 4 mm)
- Column filler : To 177-250" diatomite for gas chromatography, add chloroform containing 3% succinic acid diethylene glycol polyester and evaporate it
- Detector : Hydrogen flame ionization detector(FID)
- Column temperature : Constant temperature of 195 ~ 205°C
- Carrier gas and flow rate : N_2 and Adjust the column temperature and the flow rate of the carrier gas so that the caffeine peak appears after about 6 minutes.

(7) Selenium : 1 g of Sodium Saccharin is dissolved in 100 mL of water, and tested by Cold Vapor Type in Atomic Spectrophotometry. The absorbance should not be more than that of selenium standard solution (3 mL → 100 mL) (Not more than 30 ppm).

Loss on Drying When Sodium Saccharin is dried for 4 hours at 120°C, the weight loss should not be more than 15%.

Assay Dissolve 0.3 g of Sodium Saccharin, precisely dried and accurately weighed, in 20 mL of acetic acid (For non-aqueous titration), and titrate with 0.1 N perchloric acid (indicator: 2 drops of crystal violet-glacial acetic acid solution) until the color of the solution changes from purple through blue to green. Perform a blank test in the same manner.

1 mL of 0.1 N perchloric acid = 20.52 mg of $C_7H_4O_3NSNa$

Sodium Selenate

Chemical Formula: Na_2SeO_4

Molecular Weight: 188.94

CAS No.: 13410-01-0

Compositional Specifications of Sodium Selenate

Content Sodium Selenate should contain more than 98% of Sodium Selenate(Na_2SeO_4).

Description Sodium Selenate is white~ light gray, minute powder.

Identification

(1) Sodium Selenate responds to the test for Sodium Salt in Identification.

(2) When Sodium Selenate is quantitatively analyzed, it shows an absorption maximum at a wavelength of the Sodium Selenate standards solution.

Purity (1) Clarity and Color of Solution : Dissolve 10 g of Sodium Selenate in 100 mL of water. This solution should be clear.

(2) Grain : When observe the solution of Purity (1) under the bright light, there is no the colored particle or even though there is it, it has a little colored particle.

Assay Sodium Selenate that corresponds to about 100 mg of Selenium, is precisely weighed and is put into a flask for decomposition. Dissolve completely in 12mL of nitric acid by shaking and mixing it and boil it gradually for 15 minutes. After cooling it to room temperature, boil it with adding 80 mL of perchloric acid until smoke disappears. It is transferred into 50 mL flask and wash a flask for decomposition with ammonium chloride(4→200). Add washed solution and ammonium chloride(4→200) to make to 50mL, this solution is used as test solution. Test solution and each standard solution are tested by Atomic Absorption Spectrophotometry or Inductively Coupled Plasma Emission Spectroscopy under below operation condition using the mixed solution of ammonium chloride(4→200)-perchloric acid(20:1) as a reference. Prepare the calibration curve and obtain concentration C (mg/mL) of selenium of test solution. The content of Sodium Selenate is calculated using the following equation.

$$\text{Content of Sodium Selenate(\%)} = \frac{C \times 2.3929}{\text{Weight of sample (g)}} \times \frac{100}{1,000}$$

Standard solution : 1.0 g of selenium is precisely weighted and is dissolved in maximum volume of nitric acid. After expelling it, add 2 mL of water to evaporate to dryness. Repeat this procedure 3 times and add 3 N hydrochloric acid to make to 1 L, this solution is used as standard solution. Again take precisely 10 mL of this solution and add water to make to 100 mL. Take 5, 10 and 25 mL of this solution and

transfer each solution into flask. And add 5mL of perchloric acid into each flask and boil it slightly for 15 minutes. After cooling to room temperature, add ammonium chloride solution(4→200) to make to 100 mL. 1 mL of each solution contains 5.0, 10.0 and 25.0 mg of selenium.

Operation Condition

Fluorescent Lamp	Selenium hollow cathode lamp
Analysis line wavelength	196 nm
Combustible support gas	Air
Combustible gas	Acetylene

Sodium Selenite

Chemical Formula: Na_2SeO_3

Molecular Weight: 172.94

CAS No.: 10102-18-8

Compositional Specifications of Sodium Selenite

Content Sodium Selenite should contain within a range of 98 ~ 101% of Sodium Selenite(Na_2SeO_3).

Description Sodium Selenite is white~pale light grey, odorless crystalline powder.

Identification To 50 mg of Sodium Selenite, 5 mL of 0.1N hydrochloric acid is added and dissolved, and 50 mg of stannous chloride is added. Then yellowish brown~orange colored precipitates are generated.

Purity (1) Carbonate : 0.5g of Sodium Selenite is added to 1 mL of water and 2 mL of diluted hydrochloric acid, bubbles should not be generated.

(2) Chloride : When 0.5g of Sodium Selenite is tested by Chloride Limit Test, the content of chlorine should not be more than 0.05 mg (not more than 0.01%).

(3) Nitrate : 0.2 g of Sodium Selenite is dissolved in 3 mL of water, and brucine in sulfuric acid solution is added to make 50mL, test solution. To 2 mL of nitrate standard solution and 0.2 g of Sodium Selenite, brucine in sulfuric acid solution is added to make 50 mL, reference solution. 50 mL of brucine in sulfuric acid solution is blank test solution. Test solution, reference solution, and blank test solution are heated in a water bath for 10 minutes, rapidly cooled at room temperature. Set the spectrophotometer to zero with blank test solution, measure the absorbance at wavelength 410 nm, the absorbance of test solution should not be higher than that of reference solution (not more than 0.01%).

Solutions

Brucine in sulfuric acid solution : 600mg of brucine in sulfuric acid is dissolved in 600 mL of sulfuric acid solution(2→3) which is previously prepared, to make 1000 mL.

Nitrate standard solution : 163 mg of potassium nitrate is dissolved in water to make 100 mL, 10 mL of this solution is diluted to 1000 mL (0.01mg NO_3/mL).

(4) Selenate and Sulphate : To 0.5 g of Sodium Selenite, 20 mg of sodium carbonate and 10 mL of hydrochloric acid are added, mixed, and slowly evaporated in a hood. The residue is washed with 1 mL of hydrochloric acid, evaporated again, and dried. To dried residue, 15 mL of hot water and 1 mL of hydrochloric acid are added and tested by Sulfate Limit Test, it should not be more than the turbidity generated by 0.15 mg of sulfuric acid (not more than 0.03%).

Assay Sodium Selenite that corresponds to about 100 mg of Selenium, is precisely weighed and is put into a flask for decomposition. Dissolve completely in 12mL of nitric acid by shaking and mixing it and boil it gradually for 15 minutes. After cooling it to room temperature, boil it with adding 80 mL of

perchloric acid until smoke disappears. It is transferred into 50 mL flask and wash a flask for decomposition with ammonium chloride(4→200). Add washed solution and ammonium chloride(4→200) to make to 50mL, this solution is used as test solution. Test solution and each standard solution are tested by Atomic Absorption Spectrophotometry or Inductively Coupled Plasma Emission Spectroscopy under below operation condition using the mixed solution of ammonium chloride(4→200)-perchloric acid(20:1) as a reference. Prepare the calibration curve and obtain concentration C (mg/mL) of selenium of test solution. The content of Sodium Selenite is calculated using the following equation.

$$\text{Content of Sodium Selenite(\%)} = \frac{C \times 2.1902}{\text{Weight of sample (g)}} \times \frac{100}{1,000}$$

Standard solution : 1.0 g of selenium is precisely weighted and is dissolved in maximum volume of nitric acid. After expelling it, add 2 mL of water to evaporate to dryness. Repeat this procedure 3 times and add 3 N hydrochloric acid to make to 1 L, this solution is used as standard solution. Again take precisely 10 mL of this solution and add water to make to 100 mL. Take 5, 10 and 25 mL of this solution and transfer each solution into flask. And add 5mL of perchloric acid into each flask and boil it slightly for 15 minutes. After cooling to room temperature, add ammonium chloride solution(4→200) to make to 100 mL. 1 mL of each solution contains 5.0, 10.0 and 25.0 mg of selenium.

Operation Condition

Fluorescent Lamp	Selenium hollow cathode lamp
Analysis line wevelength	196 nm
Combustible support gas	Air
Combustible gas	Acetylene

Sodium Sesquicarbonate

Chemical Formula: $\text{Na}_2\text{CO}_3 \cdot \text{NaHCO}_3 \cdot 2\text{H}_2\text{O}$

Molecular Weight: 226.03

INS No.: 500(iii)

Synonyms: Sodium monohydrogen dicarbonate

CAS No.: 533-96-0

Compositional Specifications of Sodium Sesquicarbonate

Content Sodium Sesquicarbonate should contain within a range of 35.0~38.6% of sodium hydrogencarbonate (NaHCO_3) and 46.4~50.0% of sodium carbonate (Na_2CO_3).

Description Sodium Sesquicarbonate is white crystallite, crumb, or crystalline powder.

Identification Sodium Sesquicarbonate solution (1→10) responds to the tests for Carbonate Salts and Sodium Salts in Identification.

Purity (1) Lead : Sodium Sesquicarbonate is tested by Purity (2) for 「Sodium Metaphosphate」(not more than 2.0 ppm).

(2) Arsenic : It should be no more than 4.0 ppm tested by Arsenic Limit Test.

(3) Mercury : When Sodium Sesquicarbonate is tested by Mercury Limit Test, its content should not be more than 1.0 ppm.

(4) Iron : 0.5 g of Sodium Sesquicarbonate is dissolved in 10 mL of dilute hydrochloric acid. Water is added to this solution to bring the total volume to 50 mL. 40 mg of ammonium persulfate and 10 mL of ammonium thiocyanate solution (2→25) are added to the solution. The resulting color should not be deeper than the reference color (Not more than 0.002%).

(5) Sodium Chloride : Approximately 10 g of Sodium Sesquicarbonate is precisely weighed and dissolved in 50 mL of water. The solution is acidified slightly by adding nitric acid. 1 mL of ferric ammonium sulfate solution (8→100) and 1 mL of 0.05 N ammonium thiocyanate solution are added to the solution, which is titrated with 0.05 N silver nitrate solution until the red color disappears. The solution is back titrated with 0.05 N ammonium thiocyanate solution until it turns pale red. The total consumed amount of 0.05 N ammonium thiocyanate solution is subtracted from the consumed amount of 0.05 N silver nitrate solution (Not more than 0.5%).

1 mL of 0.05 N silver nitrate solution = 2.922 mg sodium chloride

Water Content Water content is calculated by subtracting the contents of sodium hydrogen carbonate(%), sodium carbonate(%), and sodium chloride(%) from 100%. Water content should be within a range of 13.8~16.7%.

Assay (1) Sodium Hydrogen carbonate : Approximately 3 g of Sodium Sesquicarbonate is precisely

weighed and transferred into a 600 mL beaker with 50 mL of 0.5 N sodium hydroxide solution. It is then dissolved in 150 mL of carbon dioxide free water. 200 mL of 0.48 M barium chloride (pH 8.0) is added to the beaker while stirring. The solution is titrated with 0.5 N hydrochloric acid until pH is maintained at 8.8 for 1 minute. Separately, a blank test is carried out with 2.1 g of first grade sodium carbonate standard.

$$\text{Content(\%)} = \frac{(B - S) \times 42.00}{\text{weight of the sample(mg)}} \times 100$$

S : Consumed amount of 0.5 N hydrochloric acid for Test Solution (mL)

B : Consumed amount of 0.5 N hydrochloric acid for blank test with 2.1 g of first grade sodium carbonate standard (mL)

(2) Sodium Carbonate : Total alkalinity (as sodium oxide, Na₂O) of the sample is measured. Approximately 4.2 g of Sodium Sesquicarbonate is precisely weighed and dissolved in 100 mL of water. Methyl orange solution is added and the solution is shaken vigorously. The solution is then titrated with 1N sulfuric acid. The consumed amount (mL) of sulfuric acid is S.

$$\text{Content of sodium oxide(\%)} = \frac{S \times 30.99}{\text{weight of the sample(mg)}} \times 100$$

$$\text{Content of Sodium Oxide(\%)} = [\text{Content of Sodium oxide(\%)} - (\text{content of sodium hydrogen carbonate(\%)} \times 0.3689)] \times 1.7099$$

1.7099 : Conversion factor of sodium oxide to sodium carbonate

Sodium Silicoaluminate

INS No.: 554

Synonyms: Sodium aluminosilicate

CAS No.: 1344-00-9

Definition Sodium Silicoaluminate is a kind of sodium aluminum silicate which contains $\text{Na}_2\text{O} : \text{Al}_2\text{O}_3 : \text{SiO}_2$ with a molar ration of 1:1:13.2.

Compositional Specifications of Sodium Silicoaluminate

Content Sodium Silicoaluminate, when calculated on the dried basis at 105°C for 2 hours, should contain within a range of 66.0 ~ 71.0% of silica (SiO_2), 9.0 ~ 13.0% of alumina (Al_2O_3), and 4.0 ~ 7.0% of sodium oxide (Na_2O).

Description Sodium Silicoaluminate is fine amorphous white powder or particle.

Purity (1) Arsenic : It should be no more than 4.0 ppm tested by Arsenic Limit Test.

(2) Lead : Sodium Silicoaluminate is tested by purity (2) for 「Sodium Metaphosphate」(not more than 5.0 ppm).

(3) Mercury : When Sodium Silicoaluminate is tested by Mercury Limit Test, its content should not be more than 1.0 ppm.

Loss on Drying When Sodium Silicoaluminate is dried for 2 hours at 105°C, the weight loss should not be more than 8.0%.

Loss on Ignition Sodium Silicoaluminate is dried for 2 hours at 150°C. When thermogravimetric analysis is done with 5 g of the dried material at 900°C until the weight becomes constant, the weight loss should be within a range of 8.0~13.0%.

Assay (1) Silicon Oxide : Sodium Silicoaluminate is dried for 2 hours at 105°C. Transfer 500 mg of it ,accurately weighed, into a 250 mL beaker (inner wall of the beaker is washed with a small amount of water), where 30 mL of sulfuric acid and 15 mL of hydrochloric acid are added. It is then heated until thick white smoke is generated. After cooling, 15 mL of hydrochloric acid is added again and it is then heated until thick white smoke is generated. After cooling, 70 mL of water is added to the solution, which is filtered through a Whatman No. 40 filter paper or its equivalent. The residue and the filter paper are washed with hot water until perchloric acid is removed. The residues along with that filter paper are transferred into a platinum crucible with a known weight. The content in the platinum crucible is carbonized and then heat-treated at 900°C until the weight becomes constant. It is then cooled and weighed. The residue is wetted with small amount of water, where 15 mL of hydrofluoric acid and 8 drops of sulfuric acid are added and heated on a hot plate until sulfite gas evolves. After cooling, 5 mL of water, 10 mL of hydrofluoric acid, and 3 drops of sulfuric acid are added and evaporated to dryness on a hot plate. It is heated carefully until sulfite gas subsides. It is

further heated at 900°C until the weight becomes constant. It is then cooled and weighed. The loss in weight is the weight of silicon dioxide.

(2) Aluminum Oxide : Sodium Silicoaluminate is dried for 2 hours at 105°C. 500 mg of Sodium Silicoaluminate is transferred into a platinum dish, accurately weighed, and it is wetted with 8~10 drops of water. 25 mL of 70% perchloric acid and 10 mL of hydrofluoric acid are added and it is then heated until thick white smoke is generated. After cooling, 10mL of hydrofluoric acid is added again and it is then heated until thick white smoke is generated. After cooling, the residues are dissolved in water to make 250 mL, Test Sock Solution. 10 mL of this solution is diluted to 100 mL, Test Solution. In this case, the test solution, which is not used, is collected in a 250 mL Erlenmeyer flask for quantitative analysis of sodium oxide. Adjust absorbance or water at a wavelength 309.3 nm to 0 by Atomic Absorption Spectrophotometer, prepare a calibration curve between the absorption and the aluminium concentration of Standard Solution(Standard : Aluminum chloride) which contain each 5, 10, 20 and 50 μg of aluminum per 1 mL. The concentration(C) of aluminum in 1 mL of test solution is measured from the spectrophotometer. The amount of sodium oxide is calculated from the following equation.

$$\text{Amount of aluminum oxide (mg)} = (250C \times 10 \times 1.8895)/1,000$$

(3) Sodium Oxide : The stock solution, obtained Aluminum Oxide Test, is used as Test Soluton. Adjust absorbance or water at a wavelength 589.0 nm to 0 by Atomic Absorption Spectrophotometer, and transmission of sodium chloride standard solution(1 mL of this solution contains 200 μg of sodium) to 100%. Read %transmittancy from three of standard solutions(1 mL of each solution contains 50, 100 and 150 μg) and prepare a calibration curve between the transmission and the sodium concentration. The concentration(C) of sodium in 1 mL of test solution is measured from the spectrophotometer. The amount of sodium oxide is calculated from the following equation.

$$\text{Amount of sodium oxide (mg)} = (250C \times 1,348/1,000) - F$$

F is obtained by the following method and corresponds the amount of sodium sulfate that is included in the sample. Sodium Silicoaluminate is dried for 2 hours at 105°C, 12.5 g of which is precisely weighed and mixed with 240 mL of water in a high speed blender for longer than 5 minutes. This mixture is transferred into a 250 mL volumetric flask and water is added to fill the flask, Test Solution. A stopper is placed and it is shaken to thoroughly mix the sample. Electrical conductivity is measured using an appropriate tester. Separately, a calibration curve is prepared using a set of standard solutions containing 50, 200, 500 mg of sodium sulfate per 100 mL. The concentration of sodium sulfate (C') is obtained in terms of mg from the calibration curve. F is obtained by the following equation

$$F = 0.437(2.5C' \times w/W)$$

w : amount of sample used in quantitative test of sodium oxide

W : amount of sample used to prepare test solution

Sodium Stearoyl Lactylate

INS No.: 481(i)

Synonyms: Sodium stearoyl lactate

CAS No.: 25383-99-7

Definition Sodium Stearoyl Lactylate is a mixture of sodium stearoyl lactylate (major component) and its related acids and sodium salts.

Compositional Specifications of Sodium Stearoyl Lactylate

Description Sodium Stearoyl Lactylate is white ~ yellow powder, thin platelet, or lump with unique scent.

Identification (1) 2 g of Sodium Stearoyl Lactylate is well mixed with 10 mL of dilute hydrochloric acid, which is then heated in a water bath for 5 minutes and filtered while hot. Filtrate is neutralized with ammonia standard solution. This test solution responds to the test for Sodium Salt in Identification.

(2) The filtrate in (1) responds to the test for Lactate Salt in Identification.

(3) To the filter residue in (1), add 30 mL of sodium hydroxide, which is then heated for 30 minutes in a water bath. After cooling, 20 mL of dilute hydrochloric acid is added, which is then extracted twice with 30 mL of ether. Ether extracts are added and washed with 20 mL of water, which is then dehydrated with anhydrous sodium sulfate. Ether is evaporated in a water bath. The melting point of the residue is in a temperature range of 54~69°C.

(4) 1 g of Sodium Stearoyl Lactylate dissolves instantaneously in 20 mL of benzene.

Purity (1) Acid Value : Approximately 0.5 g of Sodium Stearoyl Lactylate is accurately weighed, 20 mL mixture of alcohol and ether(1:1) is added, (heated and dissolved if necessary) test solution, and proceeded as directed under Acid Value in Fats Test. The acid value should be within a range of 60 ~ 80.

(2) Ester Value : Approximately 1 g of Sodium Stearoyl Lactylate is precisely weighed and dissolved in 25 mL of 0.5 N alcoholic potassium hydroxide and 40 mL of toluene, Test Solution. It is proceeded as directed under Saponification Value and Esther value in Fats Test, and the ester value should be within a range of 150~190.

(3) Arsenic : It should be no more than 4.0 ppm tested by Arsenic Limit Test.

(4) Lead : When 5.0 g of Sodium Stearoyl Lactylate is tested by Atomic Absorption Spectrophotometry or Inductively Coupled Plasma Emission Spectroscopy, its content should not be more than 2.0 ppm.

(5) Cadmium : When 5.0g of Sodium Stearoyl Lactylate is tested by Atomic Absorption Spectrophotometry or Inductively Coupled Plasma Emission Spectroscopy, its content should not be more than 1.0 ppm.

(6) Mercury : When Sodium Stearoyl Lactylate is tested by Mercury Limit Test, its content should not be more than 1.0 ppm.

(7) Total lactates

• Test Solution : Approximately 200 mg of Sodium Stearoyl Lactylate is accurately weighed, where 10 mL

of 0.5 N alcoholic solution of potassium hydroxide and 10 mL of water. Air condenser is attached and the solution is gently boiled for 45 minutes. Inner walls of the condenser and the flask are washed with 40 mL of water. The solution is then heated in a water bath until the scent of alcohol disappears. 6 mL of sulfuric acid (1→2) is added to the solution, which is then heated until fatty acid dissolves. The solution is then cooled to 60°C, and 25 mL of petroleum ether is added and stir mixed. This mixture is carefully transferred into a separatory funnel with a stop cock and settled until aqueous phase is separated. The aqueous phase is separated out into a 100 mL volumetric flask. Petroleum phase is washed several times with 20 mL of water each time. This water is added to the volumetric flask and the total volume is brought up to 100 mL. Test solution is prepared by adding water to 1 mL of this solution and bringing up the total solution to 100 mL.

- Test procedure : 1 mL of test solution and 1 mL of water as a reference are placed in test tubes. 1 drop of copper sulfate standard solution is added to each test tube and well mixed by shaking. 9 mL of sulfuric acid is quickly added using a burette. Stop cock is loosely placed on the test tube that is then heated at 90°C for exactly 5 minutes in a water bath. The tube is then cooled below 20°C in an ice bath for exactly 5 minutes. 3 drops of p-phenyl phenol agent are added. While shaking, the tube is heated for 30 minutes at 30°C in a water bath. The tube is then heated for 90 seconds at 90°C then cooled to room temperature with ice water. Optical density is measure using an 1 cm path length cell at a wavelength of 570 nm. Using a calibration curve, that is prepared separately, the amount of total lactates (mg) in the test solution is obtained. The amount of total lactates from Sodium Stearoyl Lactylate should be within a range of 31~34%.
- Calibration curve : Lithium lactate is dried at 105°C for 4 hours. Precisely weighed 1.067 g of dried lithium lactate is dissolved in water so that the total volume is 1000 mL. 10 mL of this solution is further diluted to 100 mL. 1, 2, 4, 6, and 8 mL of this solution is diluted to 100 mL, respectively. Each contains 1, 2, 4, 6, and 8 µg of lactic acid, respectively. 1 mL of each of this solution is taken. By following the procedure described after [1 drop of copper sulfate standard solution is added] in Test Procedure section, optical density is measured and a calibration curve is prepared.

(8) Sodium: Transfer 250 mg of Sodium Stearoyl Lactylate, accurately weighed, to a beaker, dissolve by heating in 10 mL of alcohol and quantitatively transfer the solution into a 25 mL of volumetric flask. Wash the beaker twice with 5 mL portions of alcohol, combine the washings to the flask, and add alcohol to make 25 mL. Transfer 0.25 mL of this solution, precisely weighed, to a second 25 mL volumetric flask, and add 2.5mL of lanthanum standard stock solution and water to make 25mL, Test Solution. Measure Atomic absorbance by the use of spectrophotometer by following operation condition. Separately, measure absorbance values of sodium standard solution and prepare a calibration curve. Absorbance of the test solution is substituted to the calibration curve, and the concentration of sodium C(µg/mL) is obtained. The content should be within a range of 3.5 ~ 5.0%.

- Standard Solution : Transfer 0.2, 0.4 and 0.5 mL of the sodium standard stock solution into each of 100

mL volumetric flasks, and add 10 mL of lanthanum solution, respectively and water to make 100 mL.
(1 mL of the solution contains 2.0, 4.0, and 5.0 μ g of sodium, respectively.)

$$\text{Sodium(\%)} = \frac{2.5 \times C}{\text{weight of the sample(mg)}} \times 100$$

Operation Conditions

- Gas used : Combustible gas (acetylene or hydrogen)
 Combustible support gas (air)
- Lamp : Cadmium hollow cathode lamp
- Wavelength : 589 nm

Sodium Sulfate

Chemical Formula: $\text{Na}_2\text{SO}_4 \cdot n\text{H}_2\text{O}$ ($n = 0$ or 10)

Molecular Weight: 10hydrates 322.19
anhydrous 142.04

INS No.: 514(i)

CAS No.:
7757-82-6(anhydrous)
7727-73-
3(10hydrates)

Synonyms: Glauber's salt

Definition Sodium Sulfate occurs anhydrous or contains 10 molecules of water of crystallization, each call sodium sulfate (crystal) and Sodium Sulfate (anhydrous).

Compositional Specifications of Sodium Sulfate

Content Sodium Sulfate, when calculated on the dried basis, should contain not less than 99.0% of sodium sulfate ($\text{Na}_2\text{SO}_4 = 142.05$).

Description Sodium Sulfate occurs as colorless crystals or as a white crystalline powder.

Identification Sodium Sulfate responds to the tests for Sodium Salt and Sulfate in Identification.

Purity Perform tests of Sodium Sulfate, previously dried for 4 hours at 105°C .

- (1) Clarity and Color of Solution : When 1 g of Sodium Sulfate is dissolved in 10 mL of water, the solution should be colorless and should not be more than almost clear.
- (2) Chloride : When 1 g of Sodium Sulfate is dissolved in 100 mL of water and to 10 mL of the resulting solution, 6 mL of diluted nitric acid is added, Test Solution. When the test solution is tested by Chloride Limit Test, its content should not be more than the amount that corresponds to 0.3 mL of 0.01 N hydrochloric acid.
- (3) Arsenic : It should be no more than 3.0 ppm tested by Arsenic Limit Test.
- (4) Lead : Sodium Sulfate is tested by purity (2) for 「Sodium Metaphosphate」(not more than 2.0 ppm).
- (5) Mercury : When Sodium Sulfate is tested by Mercury Limit Test, its content should not be more than 1.0 ppm.
- (6) Selenium : 0.2 g of Sodium Sulfate is precisely weighed and is tested by purity (6) for 「Sulfuric acid」(not more than 30 ppm).

Loss on Drying When Sodium Sulfate is dried for 4 hours at 105°C , the weigh loss of crystal should be within a range of 51 ~ 57%, and that of anhydrous should not be more than 1.0%.

Assay Accurately weigh about 0.4 g of Sodium Sulfate, previously dried, dissolve in 200 mL of water, add 1 mL of hydrochloric acid, boil, and add gradually 30 mL of barium chloride solution. Heat this solution in a water bath for 1 hour, cool, and filter through a filter paper for quantitative analysis. Wash the

residue on the filter paper with warm water until the washings do not respond to the test by Chloride Limit Test. Dry the residue with the filter paper. ignite to constant weight, and Accurately weigh as Barium Sulfate.

$$\text{Content of sodium sulfate(\%)} = \frac{\text{weight of BaSO}_4(\text{g}) \times 0.6086}{\text{weight of the sample (g)}} \times 100$$

Sodium Sulfit

Chemical Formula: $\text{Na}_2\text{SO}_3 \cdot n\text{H}_2\text{O}$ (n = 0 or 10)

Molecular Weight: 10hydrates 322.19
anhydrous 142.04

INS No.: 514(i)

CAS No.:
7757-82-6(anhydrous)
7727-73-
3(10hydrates)

Synonyms: Glauber's salt

Definition Sodium Sulfit occurs as crystals (heptahedra) called Sodium Sulfit (crystal) or as anhydrous called Sodium Sulfit (anhydrous).

Compositional Specifications of Sodium Sulfit

Content Sodium Sulfit, when calculated on the anhydrous basis, should contain not less than 95.0% of sodium sulfit (Na_2SO_3).

Description Sodium Sulfit occurs as colorless to white crystals or as a white powder.

Identification Sodium Sulfit responds to the tests for Sodium Salt (A) & (B) and Sulfit in Identification.

Purity In the case of Sodium Sulfit (crystal), weigh two times as much as the quantity of the sample prescribed in Purity, and perform the test.

- (1) Clarity and Color of Solution : When 0.5 g of Sodium Sulfit is dissolved in 10 mL of water, the solution should be almost clear.
- (2) Arsenic : It should be no more than 4.0 ppm tested by Arsenic Limit Test.
- (3) Lead : Sodium Sulfit is tested by purity (2) for 「Sodium Metaphosphate」(not more than 2.0 ppm).
- (4) Selenium : Transfer 2.0 g of Sodium Sulfit, precisely weighed, into a 50 mL beaker, add 10 mL of water and 5 mL of hydrochloric acid and boil to remove sulfur dioxide, Test Solution. Separately, transfer 1.0 g of Sodium sulfit ,precisely weighed, into a beaker, where 0.05 mL of selenium standard solution is added. Then a reference solution is prepared by the same manner as for test solution. 2 g of hydrazin sulfate is added to each beaker, heated and dissolved. After setting for 5 minutes, the resulting solution is transferred into a Nestler cylinder with adding water to make 50 mL. The red color of this test solution should not be deeper than that of reference solution. (Not more than 5 ppm)
- (5) Iron : When 5.0 g of Sodium Sulfit is tested by Atomic Absorption Spectrophotometry or Inductively Coupled Plasma Emission Spectroscopy, its content should not be more than 10 ppm.
- (6) Mercury : When Sodium Sulfit is tested by Mercury Limit Test, its content should not be more than 1.0 ppm.
- (7) Thiosulphate : When the 10% aqueous solution of Sodium Sulfit is acidified with Sulfuric Acid or

hydrochloric acid, it should be transparent (not more than 0.1%).

Assay Transfer a quantity of Sodium Sulfite corresponding to approximately 0.25 g of Sodium Sulfite (anhydrous) into a flask with a stopper, and dissolve it in 50 mL of 0.1 N iodine solution. After settling for 5 minutes with a stopper, 2 mL of dilute hydrochloric acid (2→3) is added. An excess amount of iodine is titrated with 0.1 N sodium thiosulfate solution. (indicator: starch solution)

1 mL of 0.1 N iodine solution = 6.302 mg Na_2SO_3

$$\text{Content of sodium sulfite}(\text{Na}_2\text{SO}_3)(\%) = a \times \frac{6.302 \times (50 - V)}{\text{weight of the sample}(\text{g}) \times 10}$$

Crystals:2

a Anhydrous:1

V : 0.1 N amount of sodium thiosulfate solution (mL)

Sorbic Acid



Chemical Formula: $\text{C}_6\text{H}_8\text{O}_2$

INS No.: 200

Molecular Weight: 112.13

CAS No.: 110-44-1

Compositional Specifications of Sorbic Acid

Content Sorbic Acid, when calculated on the dried basis, should contain within a range of 99.0 ~ 101.0% of sorbic acid ($\text{C}_6\text{H}_8\text{O}_2$).

Description Sorbic Acid occurs as colorless needles or as a white crystalline powder. It is odorless or has a slight, characteristic odor.

Identification (1) To 0.1 g of Sorbic Acid, 10 mL of water is added. The suspension solution is acidic.

(2) To 1 mL solution of Sorbic Acid in acetone (1→100), add 1 mL of water and 2 drops of bromine solution and mix. The color of the solution disappears immediately.

Purity (1) Melting Point : Melting point of Sorbic Acid should be within a range of 132 ~ 135°C.

(2) Clarity and Color of Solution : When 0.2 g of Sorbic Acid is dissolved in 5 mL of acetone, the color of the solution should not be deeper than that of Color Standard Solution C.

(3) Chloride : Weigh 1.5 g of Sorbic Acid, add 120 mL of water, and dissolve while boiling. After cooling, add water to make 120 mL, and filter. Measure 40 mL of the filtrate, and add 6 mL diluted nitric acid, Test Solution. When the test solution is tested by Chloride Limit Test, its content should not be more than the amount that corresponds to 0.2 mL of 0.01 N hydrochloric acid.

(4) Sulfate : To 40 mL of the filtrate prepared in (3) above, add 1 mL of diluted hydrochloric acid, Test Solution. When the test solution is tested by Sulfate Limit Test, its content should not be more than the amount that corresponds to 5 mL of 0.01 N sulfuric acid.

(5) Arsenic : It should be no more than 4.0 ppm tested by Arsenic Limit Test.

(6) Lead : When 5.0 g of Sorbic Acid is tested by Atomic Absorption Spectrophotometry or Inductively Coupled Plasma Emission Spectroscopy, its content should not be more than 2.0 ppm.

(7) Mercury : When Sorbic Acid is tested by Mercury Limit Test, its content should not be more than 1.0 ppm.

(8) Aldehyde : To 3.0g of Sorbic Acid, add 450 mL of water, and adjust the pH of this solution to 4 using Hydrochloric acid(1→12). Add water to make 500 mL and filter it, Test Solution. Separately, add water to 2.5mL of 40% formaldehyde solution to make 1,000mL. Accurately pipet 3 mL of this solution and add water to make 500 mL, Reference Solution. To 5 mL of each of test solution and reference solution, add 2.5 mL of fuchsin sulfurous acid test solution. Then allow the solution to stand for 15~30 minutes.

The color of test solution should not be more intense than that of reference solution. (not more than 0.1% as formaldehyde).

Water Content 2 g of Sorbic Acid is tested by Water Content Determination Method (Karl-Fischer Method). The water content should not be more than 0.5%.

Residue on Ignition When thermogravimetric analysis is done with 2 g of Sorbic Acid, the residue should not be more than 0.2%.

Assay Accurately weigh about 1 g of Sorbic Acid, dissolve in neutralized ethanol to make 100 mL, measure 25 mL of this solution, and titrate with 0.1 N sodium hydroxide (indicator : 2 ~ 3 drops of phenolphthalein solution).

1 mL of 0.1 N sodium hydroxide = 11.21 mg of $C_6H_8O_2$

Sorbitan Esters of Fatty Acids

INS No.: 491, 492, 493, 494, 495,
496

Synonyms: Sorbitan monostearate; Sorbitan
tristearate; Sorbitan monolaurate; Sorbitan
monooleate; Sorbitan monopalmitate; Sorbitan
trioleate

CAS No.:
1338-41-6; 1338-39-2; 1338-43-8; 26266-
57-9

Compositional Specifications of Sorbitan Esters of Fatty Acids

Description Sorbitan Esters of Fatty Acids is white ~yellowish brown powders, flakes, granular, waxy lumps or liquid.

Identification (1) Dissolve 0.5 g of Sorbitan Esters of Fatty Acids in 5 mL of anhydrous ethanol while heating, add 5 mL of diluted sulfuric acid, heat in a water bath for 30 minutes, and cool. Oil drops or a white to yellowish white solid is deposited. Separate the oil drops or the solid, add 5 mL of ether, and shake. It dissolves.

(2) Take 2 mL of the remaining solution after the separation of the oil drops or the solid in (1) above, add 2 mL of freshly prepared catechol solution (1→20), shake, add 5 mL of sulfuric acid, and shake. A pink to red-brown color develops.

Purity (1) Acid Value : Approximately 5 g of Sorbitan Esters of Fatty Acids is precisely weighed and dissolved in 100 mL of 1:1 mixture of alcohol and ether by heating for the test solution. This test solution is proceeded as directed under Acid Value in Fats Test. The acid value should not be more than 10.

(2) Arsenic : It should be no more than 4.0 ppm tested by Arsenic Limit Test.

(3) Lead : When 5.0 g of Sorbitan Esters of Fatty Acids is tested by Atomic Absorption Spectrophotometry or Inductively Coupled Plasma Emission Spectroscopy, its content should not be more than 2.0 ppm.

(4) Polyoxyethylene : Weigh 1 g of Sorbitan Esters of Fatty Acids, add 20 mL of water, shake well while warming, and cool. Add 10 mL of ammonium thiocyanate-cobalt nitrate solution, shake well, add 10 mL of chloroform, shake again, and allow to stand. The color of the chloroform layer should not change to blue.

Residue on Ignition When thermogravimetric analysis is done with 2 g of Sorbitan Esters of Fatty Acids, the residue should not be more than 1.5%.

D-Sorbitol

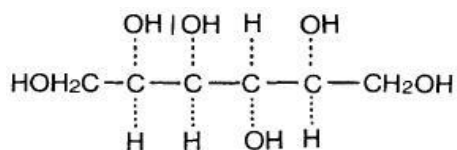

Chemical Formula: $\text{C}_6\text{H}_{14}\text{O}_6$

Molecular Weight: 182.18

INS No.: 420(i)

Synonyms: D-Glucitol; Sorbit

CAS No.: 50-70-4

Compositional Specifications of D-Sorbitol

Content D-Sorbitol, when calculated on the dried basis, should contain within a range of 97.0 ~ 101.0% of D-sorbitol ($\text{C}_6\text{H}_{14}\text{O}_6$).

Description D-Sorbitol occurs as white granules, powder, or crystalline solid. It is odorless and has a fresh, sweet taste.

Identification (1) pH : To 1 mL of D-Sorbitol solution (7→10), add 2 mL of ferrous sulfate solution and 1 mL of sodium hydroxide solution (1→5). The color of the solution changes to blue-green, but no turbidity appears.

(2) To 1 mL of D-Sorbitol solution (1→100), add 1 mL of freshly prepared catechol solution (1→10), shake well, add 2 mL of sulfuric acid, and shake. A red color develops immediately.

Purity (1) Free acid : 5 g of D-Sorbitol dissolve in 50 mL of freshly boiled and cooled water, add 1 drop of phenolphthalein solution and 0.5 mL of 0.01 N sodium hydroxide, and shake. The color of the solution changes to red color that persists for not less than 30 seconds.

(2) Arsenic : It should be no more than 4.0 ppm tested by Arsenic Limit Test.

(3) Lead : When 5.0 g of D-Sorbitol is tested by Atomic Absorption Spectrophotometry or Inductively Coupled Plasma Emission Spectroscopy, its content should not be more than 1.0 ppm.

(4) Nickel : When 5.0 g of D-Sorbitol is tested by Atomic Absorption Spectrophotometry or Inductively Coupled Plasma Emission Spectroscopy, its content should not be more than 2.0 ppm.

(5) Chloride : When 10 g of D-Sorbitol and proceed as directed under chloride, its content should not be more than the amount that corresponds to 1.5 mL of 0.01 N hydrochloric acid. (not more than 0.005%).

(6) Sulphate : When 10 g of D-Sorbitol is tested for sulphate, its content should not be more than the amount that corresponds to 2.0 mL of 0.01 N sulfuric acid (not more than 0.01%).

(7) Saccharide : 10 g of D-Sorbitol dissolve in 25 mL of water, add 8 mL of dilute hydrochloric acid,

attach a reflux condenser, heat for 3 hours in a water bath, and cool. The solution is neutralized with sodium hydroxide using methyl orange as an indicator. Bring the total volume of the solution to 100 mL with water, add 10 mL of water and 40 mL of Fehling's solution to 10 mL of the solution, boil gently for 3 minutes, allow to stand to form a precipitate of cuprous oxide, and filter the supernatant through a glass filter. Add immediately hot water to the precipitate in the flask, wash, filter through the above glass filter, and discard the washings. Repeat the procedure until the washings are no longer alkaline. Immediately dissolve the precipitate in the flask in 20 mL of ferric sulfate solution, filter through the above glass filter, wash with water, combine the filtrate and the washings, heat to 80°C and add 20 mL of 0.1 N potassium permanganate. The color of the solution should not disappear immediately.

(8) Reducing sugar : 1 g of D-Sorbitol dissolve in 25 mL of water, add 40 mL of Fehling's solution, boil gently for 3 minutes, follow the procedure in (7) Purity. In this case, 2 mL of 0.1 N potassium permanganate solution is used.

Loss on Drying When D-Sorbitol is dried for 3 hours at 80°C under a reduced pressure, the weight loss should not be more than 3%.

Residue on Ignition When thermogravimetric analysis is done with 5 g of D-Sorbitol, the residue should not be more than 0.02%.

Assay Dissolve 1 g of D-Sorbitol, precisely dried and accurately weighed, in water and then add water to make 500 mL. To 10 mL of this solution, add 50 mL of 0.3% potassium periodate solution and 1 mL of sulfuric acid, and then heat for 15 minutes in a water bath. After cooling, 2.5 g of potassium iodide is added to the solution, which is set-aside in a cold dark place for 5 minutes. Isolated iodine is titrated with 0.1 N sodium thiosulfate solution (indicator : starch solution). Separately, perform a blank test by the same procedure.

1 mL of 0.1 N Sodium thiosulfate solution = 1.822 mg $C_6H_{11}O_6$

D-Sorbitol Solution

Compositional Specifications of D-Sorbitol Solution

Content D-Sorbitol Solution should contain within a range of 67.0~73.0% of D-Sorbitol ($C_6H_{14}O_6 = 182.18$).

Description D-Sorbitol Solution is colorless transparent syrup-like liquid. Upon cooling, it may precipitate colorless crystals. It is scentless and has a sweet taste.

Identification Proceed as directed under Identification in 「D-Sorbitol」.

Purity (1) Specific Gravity : Specific gravity of D-Sorbitol Solution should not be less than 1.285.

(2) Free Acid : Dissolve 5 g of D-Sorbitol Solution in 50 mL of freshly boiled and cooled water, add 1 drop of phenolphthalein solution and 0.5 mL of 0.01 N sodium hydroxide, and shake. The color of the solution changes to red color that persists for not less than 30 seconds.

(3) Arsenic : It should be no more than 4.0 ppm tested by Arsenic Limit Test.

(4) Lead : When 5.0 g of D-Sorbitol Solution is tested by Atomic Absorption Spectrophotometry or Inductively Coupled Plasma Emission Spectroscopy, its content should not be more than 1.0 ppm.

(5) Nickel : When 5.0 g of D-Sorbitol Solution is tested by Atomic Absorption Spectrophotometry or Inductively Coupled Plasma Emission Spectroscopy, its content should not be more than 2.0 ppm.

(6) Saccharide : Dissolve 10 g of D-Sorbitol Solution in 25 mL of water, add 8 mL of dilute hydrochloric acid, attach a reflux condenser, heat for 3 hours in a water bath, and cool. The solution is neutralized with sodium hydroxide using methyl orange as an indicator. Add water to make 100 mL. Take 10 mL of this solution, add 10 mL water and 40 mL of Fehling's solution, boil gently for 3 minutes, allow to stand to form a precipitate of cuprous oxide, and filter the supernatant through a glass filter. Add immediately hot water to the precipitate in the flask, wash, filter through the above glass filter, and discard the washings. Repeat the procedure until the washings are no longer alkaline. Dissolve the precipitate in the flask in 20 mL of ferric sulfate solution, filter through the above glass filter, wash with water, combine the filtrate and the washings, heat to 80°C and add 20 mL of 0.1 N potassium permanganate. The color of the solution should not disappear immediately.

(7) Reducing Sugar : Dissolve 1 g of D-Sorbitol Solution in 25 mL of water, add 40 mL of Fehling's solution, boil gently for 3 minutes, follow the procedure in (6) Purity Saccharide. In this case, 2 mL of 0.1 N potassium permanganate solution is used.

Residue on Ignition To 5 g of D-Sorbitol Solution, 2 ~ 3 drops of sulfuric acid is added and slowly boiled by heating and ignited to ash. After thermogravimetric analysis with the residue, the amount of the final residue should not be more than 1 mg.

Assay Accurately weigh about 1 g of D-Sorbitol Solution, and dissolve in water to make 500 mL. Proceed as directed under Assay in 「D-Sorbitol」.

Spice Oleoresins

Definition Spice oleoresins are prepared by one of the following processes.

(1) Spice oleoresins is obtained by extracting each raw materials of spice with an appropriate solvent or a combination of solvents such as ethyl alcohol, methyl alcohol, trichloroethylene, acetone, isopropyl alcohol, methylene chloride, and hexane. Solvents should be removed according to the specifications in Residual Solvents.

(2) Spice oleoresins is a mixture of volatiles and non-volatiles from a spice. Volatiles in each raw materials of spice are fractionally distilled. Non-volatiles are extracted by the solvents listed in (1) and solvents are removed. In oleoresins, there are Oleoresin Thyme (origin : dried root cortex of *Thymus vulgaris* L.), Oleoresin Dill seed (origin : dried seeds of *Anethum graveolems* L.), Oleoresin Laurel Leaf (origin : dried leaves of *Laurus nobilis* L.), Oleoresin Marjoram (origin : dried root cortex of *Majorana hortensis* Moench), Oleoresin Basil, (origin : dried root cortex of *Ocimum basilicum* L.), Oleoresin Black and Oleoresin White Pepper (origin : dried fruits of *Piper nigrum* L.), Oleoresin Celery (origin : dried seeds of *Apium graveolens* L.), Oleoresin Anise (origin : dried fruits of *Pimpinella anisum* L.), Oleoresin Angelica Seed (origin : dried seeds of *Angelica archangelica* L.), Oleoresin Origanum (origin : dried leaves of *Origanum*), Oleoresin Ginger (origin : dried rootstocks of *Zingiber officinale* L.), Oleoresin Cardamom (origin : dried seeds of *Elettaria cardamomum* Maton), Oleoresin Caraway (origin : dried seeds of *Carum carvi* L.), Oleoresin Coriander (origin : dried seeds of *Coriandrum sativum* L.), Oleoresin Cumin (origin : dried seeds of *Cuminum cyminum* L.), Oleoresin Cubeb (origin : dried seeds of *Piper cubeba* L.), Oleoresin Parsley Leaf (origin : dried root cortex of *Petroselinum crispum* L.), oresin Parsley Seed (origin : dried seeds of *Petroselinum crispum* L.), Oleoresin Fennel (origin : dried leaves of *Foeniculum vulgare* P. Miller), Oleoresin Pimenta Berries (origin : dried fruits of *Pimenta officinalis* Lindl), Oleoresin Garlic (origin : bulbs or leaves of *Allium sativum* L.), Oleoresin Nutmeg (origin : seed kernel of dried mature seeds of *Myristica fragrans* Houttuyn), Oleoresin Rosemary (origin : juvenile leaves of *Rosmarinus officinalis* L.), Oleoresin Mace (origin : dried s pornioderm of dried mature seeds of *Myristica fragrans* Houtt.), Oleoresin Sage (origin : dried leaves of *Salvia officinalis* L.), Oleoresin Cinnamon (origin : dried inner barks of *Cinnamomum zeylanicum* nees), Oleoresin Onion (origin : bulbs of *Allium cepa* L.), Oleoresin Cassia (origin : dried barks of *Cinnamomum cassia* Blume), Oleoresin Capsicum (origin : dried fruits of *Capsicum annum* L. or *Capsicum frutescens* L.),

Oleoresin Clove (origin : dried flower buds of *Eugenia caryophyllata* Thunberg), and Oleoresin Tarragon (origin : leaves, stems, and flowers of *Artemisia dracunculus* L.). Dilutant, antioxidant, or other food additives (emulsifier, etc.) can be added for quality preservation.

Compositional Specifications of Spice Oleoresins

Description Spice oleoresins is liquid, viscous liquid, or semi solid material. It has characteristic scent and taste of the corresponding spice (and its raw material).

Identification (1) Dissolve 50 mg of Spice oleoresins in 10 mL of ethyl-alcohol. If necessary, Centrifuge

and use Test Solution. Separately, dissolve 1 mg of capsaicin with 10 mL of ethyl-alcohol to be used as a standard solution. Apply 10 mL of Test Solution and Standard Solution, separately, to silica gel plate for Thin Layer Chromatography. After developing the plate about 12 cm in the Developing solvent with a mixture of Ether : Ethylalcohol (19:1), and air-dry. Spray equally the plate with 2,6-Dibromoquinone-chloride solution. and set aside in ammonia gas. The spot of test solution should be same in the aspects of the color, developing distance comparing the blue spot of the standard solution(only apply for Oleoresin Capsicum).

(2) Spice oleoresins is refined by Test Procedure in Purity (4) for Volatile Oil. It is tested by (2) Solution Method in Infrared Spectrophotometry and it shows the following characteristic spectrum, except Oleoresin Capsicum.

(1) Thyme Oil



(2) Dill Seed Oil

① Dill Seed Oil, European Type



② Dill Seed Oil, Indian Type



(3) Laurel Leaf Oil



(4) Marjoram Oil

① Marjoram Oil, Spanish Type



② Marjoram Oil, Sweet



(5) Basil Oil

① Basil Oil, Comoros Type



② Basil Oil, European Type



(6) Black and White Pepper Oil



(7) Celery Seed Oil



(8) Anise Oil



(9) Angelica Seed Oil



(10) Origanum Oil, Spanish Type



(11) Ginger Oil



(12) Cardamom Oil



(13) Caraway Oil



(14) Coriander Oil



(15) Cumin Oil



(16) Cubeb Oil



(17) Parsley Herb Oil



(18) Parsley Seed Oil



(19) Fennel Oil



(20) Pimenta Oil



(21) Garlic Oil



(22) Nutmeg Oil



(23) Rosemary Oil



(24) Mace Oil



(25) Sage Oil

① Sage Oil, Dalmatian Type



② Sage Oil, Spanish Type



(26) Cinnamon Bark Oil

① Cinnamon Bark Oil, Ceylon Type



② Cinnamon Leaf Oil



(27) Onion Oil



(28) Cassia Oil



(29) Clove Leaf Oil

① Clove Leaf Oil



② Clove Oil



③ Clove Stem Oil



(30) Tarragon Oil



Purity (1) Arsenic : It should be no more than 4.0 ppm tested by Arsenic Limit Test.

(2) Lead : When 5.0 g of Spice oleoresins is tested by Atomic Absorption Spectrophotometry or Inductively Coupled Plasma Emission Spectroscopy, its content should not be more than 5.0 ppm.

(3) Residual Solvents : When Spice oleoresins is tested by Purity (5) for Paprika Extract Pigments, the content of residual solvents should be,

Methylene chloride, trichloroethylene	Not more than 30ppm (individual or total if combined))
Acetone	Not more than 30ppm
Isopropyl alcohol	Not more than 50ppm
Methyl alcohol	Not more than 50ppm
Hexane	Not more than 25ppm

(4) Volatile Oil : When Spice oleoresins is tested for the amount of volatile distillate by the following Test Procedure, it should be appropriate for the following specifications. Test Procedure. When it is diluted

with an emulsifier (a spice oleoresin type), the mixing ratio of the oleoresins is taken into account in the specifications.

- Oleoresin Thyme : 5~12 (v/w)%
- Oleoresin Dill Seed : 10~20 (v/w)%
- Oleoresin Laurel Leaf : 5~25 (v/w)%
- Oleoresin Marjoram : 10~20 (v/w)%
- Oleoresin Basil : 4~17 (v/w)%
- Oleoresin Black Pepper and oleoresin White Pepper : 15~35 (v/w)%
- Oleoresin Celery Seed : 7~20 (v/w)%
- Oleoresin Anise : 9~22 (v/w)%
- Oleoresin Angelica Seed : 2~7 (v/w)%
- Oleoresin Origanum Oil : 20~45 (v/w)%
- Oleoresin Ginger : 18~35 (v/w)%
- Oleoresin Cardamom : 50~80 (v/w)%
- Oleoresin Caraway : 10~20 (v/w)%
- Oleoresin Coriander : 2~12 (v/w)%
- Oleoresin Cumin : 10~30 (v/w)%
- Oleoresin Cubeb : 50~80 (v/w)%
- Oleoresin Parsley Herb : 2~10 (v/w)%
- Oleoresin Parsley Seed : 2~7 (v/w)%
- Oleoresin Fennel : 3~20 (v/w)%
- Oleoresin Pimenta Berries : 20~50 (v/w)%

Test Procedure : Sufficient amount of sample is precisely weighted (so that 2~5 mL of volatile oil can be collected) into a 1,000 ~ 2000 mL round bottom flask with a 24/40 ground joint neck, where a magnetic bar and 500 mL of water are added. A distilling head and reflux condenser are attached as shown in the figure. The flask is heated while stirring until the amount of the oil does not change. It is cooled to room temperature and set aside until the oil becomes clear. The volume of collected oil is measured (down to 0.02 mL) and its content is calculated by the formula;

$$\text{Content of volatile oil(V/W)\%} = \frac{\text{amount of collected oil(mL)}}{\text{weight of the sample(g)}} \times 100$$



(a) for oils heavier than water

(b) for oils lighter than water

Distilling head : Clevenger Traps (unit : mm)

(5) Piperin (only for oleoresin black pepper and oleoresin white pepper) : Preparation of Undiluted Standard Solution : Piperin is purified by recrystallization in isopropyl alcohol so that its melting point is 129~130°C. 100 mg of purified piperin as a crystal form is precisely weighted into a 100 mL flask and dissolved in dichloroethylene. Dilute it to 100 mL, and then 10 mL of this solution is rediluted to 100 mL with dichloroethylene (Undiluted Standard Solution).

- Preparation of Standard Solution : 1.0, 3.0, 5.0, and 10.0 mL (contains 0.1, 0.3, 0.5, and 1.0 mg of piperin) of undiluted Standard Solution is diluted to 100 mL with dichloroethylene (Standard Solutions).
- Preparation of Test Solution : Spice oleoresins is heated and stirred with glass rod in a 100°C steam bath or oven (hot plate should not be used). Approximately 100 mg is precisely weighted into a 100 mL flask and dissolved in dichloroethylene (total volume = 100 mL). 1 mL of this solution is further diluted to 100 mL with dichloroethylene (Test Solution).

Test Procedure : Absorptions of Test and Standard Solutions are measured at 342 nm with 1 cm path length using dichloroethylene as a standard. A standard curve of absorptions of 4 standard solutions using their concentrations (mg/100 mL) is obtained. Piperin concentration C (mg/100 mL) in the sample is obtained from the standard curve. The content of piperin in oleoresin black pepper and oleoresin white pepper is obtained by the following equation. It should not be less than 36%.

$$\text{Content of piperin(\%)} = 100 \times \frac{100C}{\text{weight of the sample(mg)}}$$

(6) Hot taste (only apply for Oleoresin Capsicum)

The hot taste of Spice oleoresins should be more than indicated contents within 100,000 through 2,000,000 tested by the following procedure.

Scoville Heat Units	Test Solution (mL)	Sugar Solution (mL)
360,000	20	10
480,000	20	20
600,000	20	30
720,000	20	40
840,000	20	50
960,000	20	60
1,080,000	20	70
1,200,000	20	80
1,320,000	20	90
1,440,000	20	100
1,560,000	20	110
1,680,000	20	120
1,800,000	20	130
1,920,000	20	140
2,040,000	20	150

- test method : Transfer 200 mg of Spice oleoresins into a 50 mL volumetric flask, and dilute to volume with alcohol. Shake the mixture and set aside to use test solution. Dissolve 0.15 g of test solution in 140 mL of sugar solution (10w/v%), and mix. This test solution is tested by following procedure. 240,000 as Scoville Heat Units is the level that three or more people sense spicy tastes when separately 5 people eat 5 mL of test solution. Dilute the test solution according to a below table in case that the unit is higher than this level.

Make the test solution by taking the test solution according to a below table in case that the Heat Units is less than 240,000.

Scoville Heat Units	Test Solution (mL)	Sugar Solution (mL)
---------------------	--------------------	---------------------

100,000	0.15	60
117,500	0.15	70
170,000	0.15	100
205,000	0.15	120

Spirulina Color

Definition Spirulina Color is a pigment obtained by extracting Spirulina Platensis (NORD.) GEITLER, which is a blue-green algae. The major pigment is Phycocyanin. Dilutant, stabilizer, or solvent can be added for the purpose of color value adjustment and quality preservation.

Compositional Specifications of Spirulina Color

Content Color value ($E_{1cm}^{10\%}$) of Spirulina Color should be higher than the indicated value.

Description Spirulina Color is blue powder having a slight characteristic odor.

Identification (1) The Test Solution obtained in Color Value section is blue and has a maximum absorption at about 618 nm.

(2) The Test Solution in (1) shows red fluorescence, which disappears after heating for 30 minutes at 90°C.

(3) When 3.9 g of ammonium sulfate is dissolved in 10 mL of the Test Solution in (1) and the solution is allowed to stand, blue precipitates are formed.

(4) When 1 mL of ferric chloride is added to 5 mL of the Test Solution in (1) and allow to stand for 20 minutes, the solution turns dark violet.

(5) When 0.1 mL of sodium hypochlorite solution (effective chlorine should not be less than 4%) is added to 5 mL of the Test Solution, the solution changes light yellow.

Purity (1) Arsenic : It should be no more than 4.0 ppm tested by Arsenic Limit Test.

(2) Lead : When 5.0 g of Spirulina Color is tested by Atomic Absorption Spectrophotometry or Inductively Coupled Plasma Emission Spectroscopy, its content should not be more than 8.0 ppm.

Assay (Color Value) Appropriate amount of Spirulina Color is precisely weighed so that the absorbance is within 0.3 ~ 0.7 and dissolved in citric acid dibasic sodium phosphate buffer solution with pH 6.0 so that the total volume is 100 mL (Test Solution). If necessary, the solution is centrifuged and the supernatant is used. Using citric acid dibasic sodium phosphate buffer solution with pH 6.0 as a reference solution, absorption A is measured at the maximum absorption at about 618 nm with 1 cm path length. Color value is obtained using the following formula.

$$\text{Color Value}(\overset{10\%}{E}_{1cm}) = \frac{A \times 10}{\text{weight of the sample(g)}}$$

• Citric acid-dibasic sodium phosphate buffer solution (pH 6.0)

Solution 1 : 0.1 M citric acid solution : 1 l of solution containing 21.01 g of citric acid (C₆H₈O₇·H₂O).

Solution 2 : 0.2 M dibasic sodium phosphate solution : 1 l of solution containing 71.63 g of dibasic sodium phosphate (Na₂HPO₄ · 12H₂O).

73.7 volume of Solution 1 and 126.3 volume of Solution 2 are mixed well and its pH is adjusted to 6.0.

Stearic Acid

Octadecanoic acid

Chemical Formula: $C_{18}H_{36}O_2$

Molecular Weight: 284.18

INS No.: 570

Synonyms: Octadecanoic acid

CAS No.: 57-11-4

Definition Stearic Acid is a solid fatty acid obtained from fats. It consists of a mixture of stearic acid ($C_{18}H_{36}O_2$) and palmitic acid ($C_{16}H_{32}O_2$). Its major component is stearic acid ($C_{18}H_{36}O_2$).

Compositional Specifications of Stearic Acid

Description Stearic Acid is white ~ pale yellow crystalline solid or powder.

Purity (1) Acid Value : When 0.5 g of Stearic Acid is precisely weighted, and proceeded as directed under Acid value in Fats Test, the Acid value should be 196~211.

(2) Solidification point : Solidification point of Stearic Acid should be 54.5~69.0.

(3) Lead : When 5.0 g of Stearic Acid is tested by Atomic Absorption Spectrophotometry or Inductively Coupled Plasma Emission Spectroscopy, its content should not be more than 1.0 ppm.

(4) Arsenic : It should be no more than 4.0 ppm tested by Arsenic Limit Test.

(5) Mercury : When Stearic Acid is tested by Mercury Limit Test, its content should not be more than 1.0 ppm.

(6) Iodine Value : Approximately 3.6 g of Stearic Acid is precisely weighted into a 500 mL Erlenmeyer flask with a stopper which contains 20 mL of 1 : 1 mixture of glacial acetic acid : cyclohexane and 25 mL of Weiss solution. A stopper is placed on the flask which is vigorously shaken and set aside for 1 hour in a dark place. 20 mL of potassium iodide solution and 100 mL of water (previously boiled and cooled) are added to the flask. The excess iodine is titrated with 0.1 N sodium thiosulfate solution. Sodium thiosulfate solution is added drop wise until yellow color disappears. Starch solution is added and the titration is continued until the blue color disappears completely. Near the end point, the flask is vigorously shaken with a stopper. Separately, a blank test is carried out by the same procedure. Iodine value is obtained by the following equation and it should not be more than 7.0.

$$\text{Iodine Value} = \frac{(B-S) \times 1.269}{\text{weight of the sample(g)}}$$

B : Consumed amount of 0.1 N sodium thiosulfate solution in the blank test (mL)

S : Consumed amount of 0.1 N sodium thiosulfate solution in the test for sample (mL)

(7) Saponification Value : 3 g of Stearic Acid is precisely weighted into a 250 mL flask, where 50 mL of 0.5 N alcoholic solution of potassium hydroxide is added. After attaching a reflux condenser, the

solution is saponified for 30 ~ 60 minutes. Cool the solution, the condenser is washed with small amount of water and removed. 1 mL of phenolphthalein TS is added. The resulting solution is then titrated with 0.5 N hydrochloric acid. The solution is boiled (red color appears again) and titrated again until the red color disappears. Saponification value is calculated using the following equation and should be 197 ~ 212.

(8) Unsaponifiable matter : 5 g of Stearic Acid is precisely weighted into a 250 mL flask, where 2 g of potassium hydroxide and 40 mL of alcohol are added and gently refluxed for 1 hour with a reflux condenser. The solution transfer into a separatory funnel (3.5 cm diameter x 30 cm length with 40 mL, 80 mL, and 130 mL scale marks) with a stopcock. The flask is washed with sufficient amount of alcohol, which is added to the funnel (total volume = 40 mL). The flask is washed with warm and cold water, which is added to the funnel (total volume = 80 mL). Finally, the flask is washed with a few mL of petroleum ether, which is added to the funnel. Cool the solution, 50 mL of petroleum ether is added to the funnel. The funnel is shaken vigorously for 1 minute and then settled to separate two phases completely. The supernatant ether layer is collected in a 500 mL separatory funnel with a stopcock. The aqueous layer is again extracted 6 times with 50 mL each of ether. These extracts are added to the first extract. The combined extracts are washed with 25 mL of 10% alcohol. This procedure is repeated until the aqueous layer doesn't get colorized by phenolphthalein TS. When this is accomplished, aqueous phase is discarded and the ether extract transfer into a pre-weighted beaker. With 10 mL of ether, the funnel is washed, which is added to the beaker. Ether layer is evaporated to dryness in a water bath, which is then dried at 100°C for 30 minutes until the weight becomes constant. Then the residue is cooled in a desiccator and weighted. The residue dissolve in 50 mL of warm alcohol (neutralized with sodium hydroxide using phenolphthalein as an indicator). The resulting solution is titrated with 0.02 N sodium hydroxide solution until a pale red color persists. The amount of oleic acid is obtained by multiplying the consumed amount of sodium hydroxide solution with 5.659(gm). The exact amount of unsaponifiables is obtained by subtracting the amount of fatty acid (as oleic acid) from the amount of residues. The content of unsaponifiable matter is calculated by the following equation and it should not be more than 1.5%.

$$\text{Unsaponifiable matter(\%)} = \frac{\text{content of residue(mg)} - \text{content as oleic acid(mg)}}{\text{weight of the sample(g)}} \times \frac{100}{1,000}$$

Water Content Water content of Stearic Acid is determined by water determination (Karl-Fisher Titration) and should not be more than 0.2%

Residue on Ignition When Residue on Ignition analysis is done with accurately weighted 2 g of Stearic Acid, the amount of Residue on Ignition should not be more than 0.1%.

Steviol Glycoside

INS No.: 960

CAS No.: 57817-89-7

58543-16-1

Synonyms: Stevioside; Rebaudioside A

Definition Steviol glycoside is obtained from *Stevia rebaudiana* Bertoni. The leaves are extracted with hot leaves and the aqueous extract is passed through an absorption resin and concentrate it. The product is recrystallized from methyl alcohol or ethyl alcohol and dried. Its major component is Steviol glucoside.

Compositional Specifications of Steviol Glycoside

Content When Steviol glycoside is dried and weighed, it should contain not less than 95.0% of whole Steviol glycoside.

Description Steviol glycoside is white to light yellow powder, flakes, or granules with strong sweet taste. It is odorless or having a slight characteristic odor.

Identification 0.5 g of Steviol glycoside is dissolved in 100 mL of water, test solution. 5 mg each of Stevioside for quantitative and Rebaudioside A is weighed and dissolved in 10 mL of water, standard solution. Liquid chromatography is carried out with test solution and standard solution under the operation conditions of assay. Retention time of the main peak of Test Solution is identical to the retention time of both peak of Stevioside and Rebaudioside or one peak of Standard Solution.

Purity (1) pH : pH of this aqueous solution (1→100) of Steviol glycoside should be 4.5~7.0 as determined by glass electrode method.

(2) Arsenic : It should be no more than 1.3 ppm tested by Arsenic Limit Test.

(3) Lead : Accurately weigh 10 g of Steviol glycoside and place in a platinum or quartz crucible. Add minute amount of sulfuric acid, wet, gradually heat and preliminarily heat-treat the solution at the temperature as low as possible. Again add 1 mL of sulfuric acid, gradually heat, ignite until it is heat-treated at 450 ~ 550°C. After heat-treating, add minute amount of nitric acid(1→150) to the residue, again, add nitric acid(1→150) to make 10 mL, test solution. When the test solution is tested by Atomic Absorption Spectrophotometry or Inductively Coupled Plasma Emission Spectroscopy, its content should not be more than 1.0 ppm.

(4) Residual solvent : 2 g of Steviol glycoside is precisely weighed into a 300 mL round bottom flask, 200 mL of water is added, boiling chips and 1 mL of silicone resin are added and mixed well. Receiver containing is connected to this, 4 mL of internal standard solution is precisely weighed and added to a 100 mL flask. While caring for the bubbles not to overflow, distill the solution at the rate of 2~3 mL per 1 minute until the milky liquid becomes about 90 mL, and water is added to make 100 mL, test

solution. However, tert-butyl alcohol (1→1,000) is used as internal standard solution. Separately, 0.5 g of methyl alcohol is precisely weighed and water is added to make 500 mL, again 2 mL of this solution and 4 mL of internal standard solution is weighed, water is added to make 100 mL, standard solution. 2µl of test solution and standard solution is taken respectively, and injected to gas chromatograph with the following operation condition. Then, ratio of methyl alcohol peak against tert-butyl alcohol peak in test Solution and standard solution, QT and QS, is calculated separately, and the content of methyl alcohol is calculated by following formula, the content should not be more than 200ppm.

$$\text{Content of methyl alcohol(\%)} = \frac{\text{Weight of methyl alcohol(g)}}{\text{Weight of sample(g)}} \times \frac{Q_T}{Q_S} \times \frac{2 \times 100}{500 \times 100} \times 100$$

QT : Ratio of methyl alcohol peak against tert-butyl alcohol peak in Test Solution

QS : Ratio of methyl alcohol peak against tert-butyl alcohol peak in standard solution

Operation Conditions

Column : PLOT Q or its equivalent

Detector : Hydrogen Flame Ionization Detector (FID)

Temperature at injection hole : 200°C

Column Temperature : 120°C

Detector temperature : 300°C

Carrier gas : Nitrogen or Helium

Ash When 1 g of Steviol glycoside is tested by Ash Limit Test, it should not be more than 1%.

Loss on Drying When 2 g of Steviol glycoside is dried for 2 hours at 105°C, the weight loss should not be more than 6%.

Assay Steviol glycoside is dried for 2 hours at 105°C, 50 ~ 100 mg of stevioside is precisely weighed, dissolved in water:acetonitrile(7:3) to make 50 mL, test solution. Separately, stevioside and rebaudioside A standard are dried for 2 hours at 105°C, 50 mg of each is precisely weighed, dissolved in water:acetonitrile(7:3) to make 50 mL, standard solution. Test and Standard Solutions are separately injected into liquid chromatography under the following operation conditions and the total amount of stevioglycoside is calculated. Peak areas and the retention time of dulcoside A, rubusoside, rebaudioside A, rebaudioside B, rebaudioside C, rebaudioside D, rebaudioside F, steviolioside and stevioside in Test Solution are obtained. and compare them for the identification. The amount of the 8 components except rebaudioside A, and the amount of rebaudioside are obtained by the following formula. The sum of these amount is the amount of steviol glycoside.

$$X (\%) = \frac{W_s}{W_t} \times \frac{A_x \times f_x}{A_s \times f_s} \times 100$$

$$\text{Rebaudioside A\%} = \frac{W_R}{W} \times \frac{A_X}{A_R} \times 100$$

X : Each steviol glycoside

W_s : Amount of Stevioside in standard solution (mg)

W_R : Amount of Ribaudioside A in standard solution (mg)

W : Amount of Sample in test solution (mg)

A_s : Peak area of stevioside in standard solution

A_R : Peak area of Rebaudioside A in standard solution

A_x : Peak area of X in test solution

f_x : Ratio of molecular weight of X to stevioside

(stevioside 1.00, rebaudioside A 1.20, rebaudioside B 1.00, rebaudioside C 1.18, rebaudioside D 1.40, Ribaudioside F 1.16, dulcoside A 0.98, rubusoside 0.80, steviolvioside 0.80)

Operation Conditions

-Detector : UV 210 nm

-Column : Capcell pak C18 MG II(4.6mm×250mm, 5μm) or its equivalent

-Column Temperature : 40°C

-Mobile Phase : Acetonitrile : 10 mM phosphoric acid buffer(pH 2.6) (32:68)

-Flow Rate : 1.0 mL/min

- The amount of Injection : 10 μL

Solutions

10 mM phosphoric acid buffer(pH 2.6)

Dissolve 1.1998 g of sodium phosphate, monobasic in water to make 1,000 mL. Add phosphoric acid(1→10) to adjust pH to 2.6.

Succinic Acid

C

H

²

□

C

O

O

H

□

C

H

²

□

C

O

O

H

Che

mic

al

For

mul

a:

C₄H

₆O₄

Mol

ecul

ar

Wei

ght:

118.

09

Syn

IN

S

N

o.:

36

3

C

A

S

N
o.:
11
0-
15
-6

Compositional Specifications of Succinic Acid

Content Succinic Acid should contain not less than 99.0% of succinic acid (C₄H₆O₄).

Description Succinic Acid occurs as colorless to white crystals or as a white crystalline powder. It is odorless and has a characteristic acid taste.

Identification Succinic Acid responds to the test for Succinic Acid salt in Identification.

Purity (1) Melting Point : Melting point of Succinic Acid should be within a range of 185 ~ 190°C.

(2) Lead : When 5.0 g of Succinic Acid is tested by Atomic Absorption Spectrophotometry or Inductively Coupled Plasma Emission Spectroscopy, its content should not be more than 5.0 ppm.

(3) Mercury : When Succinic Acid is tested by Mercury Limit Test, its content should not be more than 1.0 ppm.

(4) Readily Oxidizable Substances : Weigh 1 g of Succinic Acid, dissolve in 25 mL of water and 25 mL of diluted sulfuric acid. Add 4 mL of 0.1 N potassium permanganate, and keep 20°C. The color of the solution should not disappear within 3 minutes.

(5) Arsenic : It should be no more than 4.0 ppm tested by Arsenic Limit Test.

Residue on Ignition When thermogravimetric analysis is done with Succinic Acid, the residue should not be more than 0.025%.

Assay Accurately weigh about 1 g of Succinic Acid, and dissolve in water to make exactly 250 mL. Take 25 mL of this solution, and titrate with 0.1 N sodium hydroxide (indicator : 2 ~ 3 drops of phenolphthalein solution)

1 mL of 0.1 N sodium hydroxide = 5.904 mg of $C_4H_6O_4$

Sucralose

Chemical Formula: $C_{12}H_{19}Cl_3O_8$

Molecular Weight: 397.64

INS No.: 955

Synonyms: 4,1',6'-Trichlorogalactosucrose

CAS No.: 56038-13-2

Compositional Specifications of Sucralose

Content Sucralose, when calculated on the dried basis(anhydrous), should contain within a range of 98.0~102.0% of sucralose ($C_{12}H_{19}Cl_3O_8$).

Description Sucralose is scentless white ~ pale grayish white crystalline powder with strong sweet taste. It is readily soluble in water, methyl alcohol, and ethyl alcohol but hardly soluble in ethyl acetate.

Identification (1) When Sucralose is tested according to (1) potassium bromide disk method in Infrared Spectrophotometry, the maximum absorption should be appear at the same wavelength as a sucralose standard.

(2) 1.0 g of Sucralose is dissolved in 10 mL of methyl alcohol (Test Solution). Using sodium chloride solution (1→20) · acetonitrile mixture (7:3) as a developing solution, 5 μ l of the Test Solution is analyzed with thin layer chromatography. A spot appears at ratio of front (R_f) of 0.4 ~ 0.6. Here, silylated silica gel with octadecyl group is used as porous support material for the thin layer plate. Developing is stopped when the solvent front reaches approximately 15 cm and the solvent is evaporated with wind. Then, 15% sulfuric acid-methyl alcohol solution is sprayed. The spot is colorized by heating for 10 minutes at 125°C.

Purity (1) Specific Rotation : 1.0 g of Sucralose is precisely weighed and dissolved in water (total volume 10 mL). Optical rotation of the solution is measured. When it is translated to a dehydrated form, $[\alpha]_D^{20}$ = +84.0~+87.5°

(2) Lead : When 5.0 g of Sucralose is tested by Atomic Absorption Spectrophotometry or Inductively Coupled Plasma Emission Spectroscopy, its content should not be more than 1.0 ppm.

(3) Arsenic : It should be no more than 4.0 ppm tested by Arsenic Limit Test.

(4) Chlorinated Disaccharides : 1.0 g of Sucralose is dissolved in 10 mL of methyl alcohol (Test Solution). Dissolve 1.0 g of standard in 10mL of methyl alcohol(Control solution A). Measure 0.5mL of the control solution A, and add methyl alcohol to make 100mL(Control solution B). Analyze a 5ul portion each of the test solution, control solution A, and control solution B by thin layer chromatography following Identification (2). The main spot from the test solution corresponds to the spot from the control solution A. Even if any other spot is observed, it does not have a darker color than the spot from the control solution B(0.5%).

(5) Chlorinated Monosaccharides : 2.5 g of Sucralose is dissolved in methyl alcohol so that the total volume is precisely 10 mL (Test Solution). Separately, 10 g of D-mannitol is precisely weighed and dissolved in water so that the total volume is 100 mL (Reference Solution (A)). 10 g of D-mannitol and 40 mg of fructose are precisely weighed and dissolved in water so that the total volume is 100 mL (Reference Solution (B)). 1 µl of each solution is drop-wise added and dried on to a silica gel thin layer plate. This operation is repeated 4 times. After spraying p-anisidinephthalic acid solution, the thin layer plate is heated for 10 minutes at 98 ~ 102°C to colorize the spots. Spots for Test Solution should not be darker than those for Reference Solution (B) (not more than 0.16%). If there are any spots in Reference Solution (A), this procedure is repeated.

Solution

• p-anisidinephthalic acid solution : 1.23 g p-anisidine and 1.66 g phthalic acid are dissolved in methyl alcohol (total volume 100 mL). The solution is stored in a Light-resistant container in a cool place.

(6) Triphenyl Phosphine Oxide : Approximately 100 mg of Sucralose is precisely weighed and dissolved in acetonitrile-water mixture (67:33) so that the total volume is 10 mL (Test Solution). Separately, 100 mg of triphenyl phosphine oxide is precisely weighed and dissolved in acetonitrile-water mixture (67:33) so that the total volume is 10 mL. 1 mL of this solution is diluted to 100 mL with acetonitrile-water mixture (67:33) (Standard Solution). 25 µl of each solution is injected into a liquid chromatography using the following operation conditions and the content of triphenylphosphineoxide (mg/kg) is obtained. The content should not be more than 150 mg/kg.

$$\text{Content of triphenyl phosphine oxide (C}_{18}\text{H}_{15}\text{OP) (mg/kg)} = \frac{A_t}{A_s} \times \frac{10,000}{W}$$

A_t : Peak area in Test Solution

A_s : Peak area in Standard Solution

W : Weight of the sample (mg)

Operation Conditions

-Detector : UV 220 nm

-Column : Rad Pak C₁₈(inner diameter 8 mm, length 15 cm) or its equivalent

-Column Temperature : 40°C

-Mobile Phase : Acetonitrile-water mixture(67 : 33)

-Flow Rate : 1.5 mL/min

(7) Methyl Alcohol : Approximately 2.0 g of Sucralose is precisely weighed and dissolved in water so that the total volume is 10 mL (Test Solution). Separately, 2 mL of methyl alcohol is precisely weighed and dissolved in water so that the total volume is 100 mL. 1 mL of this solution is diluted to 100 mL with water (Standard Solution). 1 µl of each solution is injected into a gas chromatography using the following operation conditions and the content of methyl alcohol (%) is obtained. The content should not be more than 0.1%.

$$\text{Content of Methyl Alcohol (\%)} = \frac{St \times Cs \times Vt}{As \times Wt}$$

St : Peak area of Test Solution

Cs : Concentration of methyl alcohol in Standard Solution (%)

Vt : Used amount of Test Solution for the test (mL)

As : Peak area of Standard Solution

W : Weight of the sample (g)

Operation Conditions

- Column : A glass tube with inner diameter of 2 ~ 4 mm and length of 2 m
- Column Filler : 80 ~ 100 mesh coated with Porapak P.S. or its equivalent
- Detector : (Hydrogen) Flame Ionization Detector (FID)
- Temperature at injection hole : 200°C
- Column Temperature : constant temperature in a range of 140 ~ 160°C
- Detector Temperature : 250°C
- Carrier gas and flow rate : Nitrogen or Helium, 20 mL/min

Water Content Water content in approximately 1 g of Sucralose is determined by water determination (Karl-Fisher Titration) and should not be more than 2.0%.

Residue on Ignition When thermogravimetric analysis is done, the amount of residue should not be more than 0.7%.

Assay Approximately 1 g of Sucralose is precisely weighed and dissolved in acetonitrile · water mixture (15:85) so that the total volume of the solution is 100 mL. This solution is filtered through a 0.45 µm filter (Test Solution). Separately, approximately 1,000 mg of sucralose standard is precisely weighed and dissolved in acetonitrile-water mixture (15:85) so that the total volume of the solution is 100 mL (Standard Solution). 20 µL of each Standard Solution and Test Solution is injected into liquid chromatography using the following operation conditions. The content (%) of sucralose is obtained from the following equation.

$$\text{Content of sucralose(\%)} = \frac{At \times Ws}{As \times Wt} \times 100$$

At : Peak area of Test Solution

As : Peak area of Standard Solution

Wt : Weight of the sample (mg)

Ws : Weight of standard (mg)

Operation Conditions

- Detector : UV 190 nm or Differential refractometer (RI Detector)

- Column : Rad Pak C₁₈(inner diameter 8 mm, length 10 cm) or its equivalent
- Column Temperature : room temperature
- Mobile Phase : acetonitrile-water mixture (15:85)
- Flow Rate : 1.5 mL/min

Sucrose Esters of Fatty Acids

Synonyms: Sucrose fatty acid esters,

Sucrose acetate isobutyrate

INS No.: 473, 444

Compositional Specifications of Sucrose Esters of Fatty Acids

Definition Sucrose Esters of Fatty Acids are esters of fatty acids and sucrose and sucrose acetate isobutylate.

Description Sucrose Esters of Fatty Acids occur as white to yellow ~ brown powder or mass substances, or as colorless to light brown, viscous resinous or liquid substances. They are odorless or have a slight, characteristic odor.

Identification (1) To 1 g of Sucrose Esters of Fatty Acids, add 25 mL of 0.5 N alcoholic potassium hydroxide solution, equip with a reflux condenser, and heat in a water bath for 1 hour. Add 50 mL of water to the solution, and distill until the residual solution becomes about 30 mL. After cooling, add 5 mL of diluted hydrochloric acid to the residual solution, shake well, add sodium chloride to make a saturated solution, and extract twice with 30 mL of ether each time. Combine the ether layers, wash with 20 mL of water. Evaporate the ether and cool the residue to 5°C. Either colorless to light yellow solids are deposited or a liquid with an odor of acetic acid and isobutyric acid remains.

(2) Place 2 mL of the water layer separated from the ether layer in (1) above in a test tube. warm in a water bath until the odor of ether disappears. cool, and superimpose gently 1 mL of anthrone solution along the tube wall. The color of the interface changes to a blue to green color.

Purity (1) Acid Value : Accurately weigh about 3 g of Sucrose Esters of Fatty Acids, and dissolve in 40 mL of isopropyl alcohol and 20 mL of water and test by Acid Value in Flavoring Substance Test. It should not be more than 6.

(2) Arsenic : It should be no more than 4.0 ppm tested by Arsenic Limit Test.

(3) Lead : When 5.0 g of Sucrose Esters of Fatty Acids is tested by Atomic Absorption Spectrophotometry or Inductively Coupled Plasma Emission Spectroscopy, its content should not be more than 2.0 ppm.

(4) Cadmium : When 5.0 g of Sucrose Esters of Fatty Acids is tested by Atomic Absorption Spectrophotometry or Inductively Coupled Plasma Emission Spectroscopy, its content should not be more than 1.0 ppm.

(5) Mercury : When Sucrose Esters of Fatty Acids is tested by Mercury Limit Test, its content should not be more than 1.0 ppm.

(6) Other solvent(sucrose acetate isobutylate is excluded) : When Sucrose Esters of Fatty Acids proceed under following (A) and (B),

Isopropyl Alcohol not more than 350 ppm(separate or

Ethyl acetate	} total in case of use in combination)
Propylene glycol	
Isobutyl alcohol	not more than 10 ppm
Methyl Alcohol	not more than 10 ppm
Methyl ethyl ketone	should not be more than 10 ppm

(A) Isopropyl Alcohol, Ethyl Acetate, Isobutyl alcohol, Methyl Alcohol and Methyl Ethyl Ketone :
 Accurately weigh 1 g of sample into each of four sample vials. To one vial, add 5 mL of water, to the second, third, and fourth, add, respectively, standard solution A, B, and C, and seal them quickly with a septum. Place the sample vials in a headspace sampler and analyze by gas chromatography with a head space sampler using the following conditions. Measure peak area of each solvent in test solution and standard solution (Isopropyl Alcohol, Ethyl acetate, Isobutyl alcohol, Methyl Alcohol and Methyl ethyl ketone). Following standard addition method, plot the relationship between addition weight of solvent of each standard solution on a horizontal axis, and each peak area on a vertical axis. Calculate weight of each solvent of sample by the distance between the node of correlation line and horizontal axis, and the starting point.

Standard solution A, B, and C : Prepare standard solution A of methanol isopropanol, isobutanol, ethyl acetate and methyl ethyl ketone by weighing accurately 0.2g of each solvent into a 50mL volumetric flask containing approx 20 mL of water, then adding water to volume. Pipette accurately 5 mL and 10 mL of standard solution, dilute to 20 mL with water respectively, and each of them is standard solution B and C.

Operation Condition

Column : HP-1 or its equivalent

Detector : Hydrogen Flame Ionization Detector (FID)

Temperature at injection hole: 110°C

Column Temperature : 40°C

Carrier gas : Nitrogen

Headspace sampler condition

Heat temperature : 80°C

Heat time : 40 minutes

(B) Propylene Glycol : Accurately weigh 1 g of sample into a 10 mL volumetric flask, and add 0.1 mL of internal standard solution. Dissolve and make to volume with pyridine. Take 0.5 mL of sample in a centrifugation tube, and add 0.25 mL of hexamethyldisilazane and 0.1 mL of trimethylchlorosilane. After sealing the tube, shake it vigorously, let stand for 30 min at room temperature, then centrifuge. The supernatant is used as test Solution. The test solution proceed as gas chromatography with operation conditions below and calculate the concentration of Propylene Glycol from calibration

curve by internal standard method

Internal standard solution : Weigh 0.025 g of ethylene glycol and add pyridine to make 50mL.

Standard solution : Accurately weigh 0.025 g of Propylene Glycol and add pyridine to make 50 mL. Take 40, 200, 500, and 1,000 μ l of this solution into 10 mL volumetric flask respectively. Add 0.1 mL of internal standard solution to each volumetric flask and make exactly 10 mL with pyridine. Prepare each standard solution in the same manner as test solution.

Calibration Curve Preparation : Standard solutions of 4 different concentration proceed by gas chromatography under operation conditions below and prepare calibration curve.

Operation Condition

Column : HP-1(30m \times 0.32mm, 0.25 μ m) or its equivalent

Detector : Hydrogen Flame Ionization Detector (FID)

Temperature at injection hole: 230 $^{\circ}$ C

Amount of injection : 1 μ l

Type of injection : splitless

Column Temperature : Hold for 5 min at 60 $^{\circ}$ C and then 40 $^{\circ}$ C to 250 $^{\circ}$ C at 20 $^{\circ}$ C/min, and hold for 5 min at 250 $^{\circ}$ C.

Carrier gas : helium

Flow rate : Adjust flow rate so that Propylene Glycol derivatives is kept about 8 minutes

(7) Dimethyl Sulfoxide(sucrose acetate isobutylate is excluded) : 5 g of Sucrose Esters of Fatty Acids is precisely weighed and dissolved in tetrahydrofuran to make 25mL, test solution. Test solution proceeds gas chromatography under operation conditions below and measure the content of Dimethyl sulfoxide from calibration curve., its content should not be more than 2.0 ppm.

Standard solution : 0.1g of Dimethyl sulfoxide is precisely weighed and dissolved in tetrahydrofuran to make exactly 100 mL, undiluted standard solution. Each of 0.5, 1, 2, and 5 mL of undiluted standard solution is respectively measured and make exactly 50 mL with tetrahydrofuran, standard solution.

Calibration Curve Preparation : Different concentration of 4 standard solutions proceed gas chromatography under operation conditions below and prepare calibration curve.

Operation Condition

Column : HP-FFAP or its equivalent

Detector : Flame Photometric Detector (FPD)

Temperature at injection hole: 210 $^{\circ}$ C

Amount of injection : 3 μ l

Type of injection : splitless

Column Temperature : 150 ~ 170 $^{\circ}$ C

Carrier gas : Nitrogen

Flow rate : flow rate is adjusted so that Propylene Glycol derivatives is kept about 8 minutes

(8) Free Sucrose : Accurately weigh about 2 g of Sucrose Esters of Fatty Acids, add 40 mL of n-butanol, dissolve while warming on a water bath, extract twice with 20 mL of sodium chloride solution (1→20) each time, combine the extracts. add 2 mL of diluted hydrochloric acid, and heat in a water bath for 30 minutes. Cool, add 2 ~ 3 drops of phenolphthalein solution, neutralize with 1 N sodium hydroxide solution, and add water to make 100 mL. Use this solution as the sample solution. Take 20 mL of this solution, add 20 mL of Bertrand's solution A and 20 mL of Bertrand's solution B, boil gently for 3 minutes, and allow to stand to precipitate cuprous oxide (at this time, the color of the supernatant changes to deep blue). Filter the supernatant through a glass filter, wash the precipitate in the flask with hot water until the washings are no longer alkaline, and filter the washings through the glass filter (taking care not to allow cuprous oxide to be exposed to air). Dissolve the precipitate in the glass filter in 20 mL of Bertrand's solution C into Erlenmeyer flask or other suitable containers. Filter the solution through the above glass filter, wash with water, combine the filtrate and the washings, and titrate with Bertrand's solution D. Calculate the amount of copper from the consumed volume, determine the amount of invert sugar from Bertrand's Table, and calculate the content of free sucrose by the following formula. Its content should not be more than 5%.

$$\text{Content of free sucrose(\%)} = \frac{\text{weight of the invert sugar(mg)} \times 0.95 \times 5}{\text{weight of the sample(mg)}} \times 100$$

Quantitative Table for Sugars

sugar (mg)	equivalent weight for each sugar (mg)	sugar (mg)	equivalent weight for each sugar (mg)

	invert sugar	glucose	galactose	maltose	lactose		invert sugar	glucose	galactose	maltose	lactose
10	20.6	20.4	19.3	11.2	14.4	26	51.7	51.5	48.9	28.9	36.6
11	22.6	22.4	21.2	12.3	15.8	27	53.6	53.4	50.7	30.0	38.0
12	24.6	24.3	23.0	13.4	17.2	28	55.5	55.3	52.5	31.3	39.4
13	26.5	26.3	24.9	14.5	18.6	29	57.4	57.2	54.4	32.2	40.7
14	28.5	28.3	26.7	15.6	20.0	30	59.3	59.1	56.2	33.3	42.1
15	30.5	30.2	28.6	16.7	21.4	31	61.1	60.9	58.0	34.4	43.4
16	32.5	32.2	30.5	17.8	22.8	32	63.0	62.8	59.0	35.5	44.8
17	34.5	34.2	32.3	18.9	24.2	33	64.8	64.6	61.5	36.5	46.1
18	36.4	36.2	34.2	20.0	25.6	34	66.7	66.5	63.3	37.6	47.4
19	38.4	38.1	36.0	21.1	27.0	35	68.5	68.3	65.0	38.7	48.7
20	40.4	40.1	37.0	22.2	28.4	36	70.3	70.1	66.8	39.8	50.1
21	42.3	42.0	39.7	23.3	29.8	37	72.2	72.0	68.6	40.9	51.4
22	44.2	43.9	41.6	24.4	31.1	38	74.0	73.8	70.4	41.9	52.7
23	46.1	45.8	43.4	25.5	32.5	39	75.9	75.7	72.1	43.0	54.1
24	48.0	47.7	45.2	26.6	33.9	40	77.7	77.5	73.9	44.1	55.4
25	49.8	49.6	47.0	27.7	35.2	41	79.5	79.3	75.6	45.2	56.7

sugar (mg)	equivalent weight for eQach sugar (mg)					sugar (mg)	equivalent weight for eQach sugar (mg)				
	invert sugar	glucose	galactose	maltose	lactose		invert sugar	glucose	galactose	maltose	lactose
42	81.2	81.1	77.4	46.3	58.0	72	132.4	133.1	128.3	78.6	96.9
43	83.0	82.9	79.1	47.4	59.3	73	134.0	134.7	130.0	79.7	98.0
44	84.8	84.7	80.8	48.5	60.6	74	135.6	136.3	131.5	80.8	99.1
45	86.5	86.4	82.5	49.5	61.9	75	137.2	137.9	133.1	81.8	100.4
46	88.3	88.2	84.3	50.6	63.3	76	138.9	139.6	134.8	82.9	101.7
47	90.1	90.0	86.0	51.7	64.6	77	140.5	141.2	136.4	84.0	102.9
48	91.9	91.8	87.7	52.8	65.9	78	142.1	142.8	138.0	85.1	104.2
49	93.6	93.6	89.5	53.9	67.2	79	143.7	144.5	139.7	86.1	105.4
50	95.4	95.4	91.2	55.0	68.5	80	145.3	146.1	141.3	87.2	106.7
51	97.1	97.1	92.6	56.1	69.8	81	146.9	147.7	142.9	88.3	107.9
52	98.9	98.9	94.6	57.1	71.1	82	148.5	149.3	144.6	89.4	109.2
53	100.6	100.6	96.3	58.2	72.4	83	150.0	150.9	146.2	90.4	110.4
54	102.2	102.3	98.0	59.3	73.7	84	151.6	152.5	147.8	91.5	111.7
55	104.0	104.1	99.7	60.3	74.9	85	153.2	154.0	149.4	92.6	112.9
56	105.7	105.8	101.5	61.4	76.2	86	154.8	155.6	151.1	93.7	114.1
57	107.4	107.6	103.2	62.5	77.5	87	156.4	157.2	152.7	94.8	115.4
58	109.2	109.3	104.9	63.5	78.8	88	157.9	158.8	154.3	95.8	116.6
59	110.9	111.1	106.6	64.6	80.1	89	159.5	160.4	156.0	96.9	117.9
60	112.6	112.8	108.3	65.7	81.4	90	161.1	162.0	157.6	98.0	119.1
61	114.3	114.5	110.0	66.8	82.7	91	162.6	163.6	159.2	99.0	120.3
62	115.9	116.2	111.6	67.9	83.9	92	164.2	165.2	160.8	100.1	121.6
63	117.6	117.9	113.3	68.9	85.2	93	165.7	166.7	162.4	101.1	122.8
64	119.2	119.6	115.0	70.0	86.5	94	167.3	168.3	164.0	102.0	124.0
65	120.9	121.3	116.6	71.1	87.7	95	168.8	169.9	165.6	103.2	125.1
66	122.6	123.0	118.3	72.2	89.0	96	170.3	171.5	167.2	104.2	126.5
67	124.2	124.7	120.0	73.3	90.3	97	171.9	173.1	168.8	105.3	127.7
68	125.9	126.4	121.7	74.3	91.6	98	173.4	174.6	170.4	106.3	128.9
69	127.5	128.1	123.3	75.4	92.8	99	175.0	176.2	172.0	107.4	130.2
70	129.2	129.8	125.0	76.5	94.1	100	176.5	177.8	173.6	108.4	131.4
71	130.8	131.4	126.6	77.6	95.4						

(9) Dimethylformamide : 2 g of Sucrose Esters of Fatty Acids dissolve in tetrahydrofuran to make exactly 20mL. Test solution proceeds by gas chromatography under operation conditions below and calculate the concentration of Dimethylformamide from calibration curve. The concentration should not be more than 1.0 ppm.

Standard solution : Accurately weigh 0.1g of dimethylformamide dissolve in tetrahydrofuran to make 100 mL. Accurately pipette 1 mL of this solution and make 100 mL with tetrahydrofuran, stock standard solution. Take each of 0.5, 1, and 2 mL of stock standard solution respectively and make exactly 100 mL with tetrahydrofuran, standard solution.

Calibration Curve Preparation : 3 standard solutions proceed gas chromatography under operation conditions below and prepare calibration curve.

Operation Condition

Column : HP-FFAP or its equivalent

Detector : Nitrogen Phosphours Detector (NPD)

Temperature at injection hole: 180°C

Amount of injection : 1µl

Type of injection : splitless

Column Temperature : Keeping at 40°C for 2 minutes, it is raised as the rate of 20°C/minutes by 160°C, keep at 160°C for 2 minutes

Carrier gas : Helium

Water Content Approximately 500 mg of Sucrose Esters of Fatty Acids is precisely weighed and tested by the back titration method in water content determination (Karl-Fischer Method). The water content should not be more than 4%. However, Sucrose Esters of Fatty Acids transfer into a dried titration flask, where 10 mL of Karl-Fischer methyl alcohol is added and Karl-Fischer solution (approximately 10 mL excess) is added. It is sealed and stir-mixed for 20 minutes. It is titrated with water-methyl alcohol standard solution while stirring vigorously. Separately, a blank test is carried out.

Residue on Ignition When thermogravimetric analysis is done with 1 g of Sucrose Esters of Fatty Acids, the amount of residues should not be more than 2%.

Sulfur Dioxide

Chemical Formula SO_2
Molecular Weight 64.06

Sulfuric Acid

Chemical Formula: H₂SO₄

Molecular Weight: 98.08

INS No.: 513

Synonyms: Dihydrogen sulfate

CAS No.: 7664-93-9

Compositional Specifications of Sulfuric Acid

Content Sulfuric Acid should contain not less than 94.0% of sulfuric acid (H₂SO₄).

Description Sulfuric Acid is a colorless or slightly brownish, transparent or almost transparent, viscous liquid.

Identification (1) Sulfuric Acid solution (1→100) is strongly acidic.

(2) Sulfuric Acid solution (1→100) responds to the test for Sulfate Limit Test in Identification.

Purity (1) Chloride : When 2 g of Sulfuric Acid is tested by Chloride Limit Test, its content should not be more than the amount that corresponds to 0.3 mL of 0.01 N hydrochloric acid.

(2) Nitrate : Weigh 5 g of Sulfuric Acid, add gradually to 8 mL of water, add 1 mL of a solution of brucine in sulfuric acid (1→500) and sulfuric acid to make 25 mL. shake well, and warm at about 80°C for 10 minutes. This solution is used as the test solution. Measure 0.5 mL of Nitrate Standard Solution, add 8 mL of water, add 5 mL of sulfuric acid gradually, add 1 mL of a solution of brucine in sulfuric acid (1→500) and sulfuric acid to make 25 mL. shake well, and warm at about 80°C for 10 minutes. This solution is used as the reference solution. The color of the test solution is not darker than that of the reference solution.

(3) Arsenic : It should be no more than 4.0 ppm tested by Arsenic Limit Test.

(4) Lead : Accurately weigh 5.0 g of Sulfuric Acid, where water is added to make 25 mL, is tested by Atomic Absorption Spectrophotometry or Inductively Coupled Plasma Emission Spectroscopy, its content should not be more than 2.0 ppm.

(5) Mercury : When Sulfuric Acid is tested by Mercury Limit Test, its content should not be more than 1.0 ppm.

(6) Selenium : 0.3 g of Sulfuric Acid, precisely weighed, is carefully transferred into a 150 mL beaker, where 25 mL of 4 N hydrochloric acid is previously added, and it is mixed and heated until it boils. Heat this solution for 15 minutes in a water bath, add 25 mL of water, and cool, Test Solution. For reference solution, 2 mL of standard solution is weighed, transferred into a beaker and titrated with 50 mL of 2N hydrochloric acid. 50 mL of 2N hydrochloric acid is used for blank test solution. 5 mL of ammonia water is carefully added to test solution, reference solution, and blank test solution. After cooling, adjust pH of each solution 1.8 ~ 2.2 with using ammonia water(1→2). To each solution, 0.2 g of Hydroxylamine Hydrochloride is added, carefully shaken, and dissolved. Then 2,3-Diamino

Naphthalene solution is added, mixed, set aside for 100 minutes. Transfer each solution to separatory funnel, wash with 10 mL of water, add, and extract with 5 mL of cyclohexene. The aqueous layer is discarded, cyclohexene layer is centrifuged to remove slight amount of water. When absorption is analyzed at a wavelength of 380nm, the absorption of Test Solution should not be higher than that of the Standard Solution (Not more than 20 ppm).

Standard solution : Dilute Selenium standard solution or selling standard solution to 3 ppm with water.

2,3-Diamino naphthalene solution : Dissolve 0.1 g of 2,3-Diamino naphthalene solution and 0.5 g of hydroxylamine hydrochloride in 0.1N hydrochloric acid to make 100 mL.

7) (7) Iron : To 5.0 g of Sulfuric acid, add water to make 25 mL, test solution. When the solution is tested by Atomic Absorption Spectrophotometry or Inductively Coupled Plasma Emission Spectroscopy, its content should not be more than 20 ppm.

(8) Readily Oxidizable Substances : Weigh 8 g of Sulfuric Acid, add to 10 mL of water while cooling, and add 0.1 mL of 0.1 N potassium permanganate. The pink color of the solution should not disappear within 5 minutes.

(9) Reducing substances : Weigh 8 g of Sulfuric Acid, add to 50 mL of iced water and carefully titrate. Add 0.1 mL of 0.1 N potassium permanganate. The pink color of the solution should not disappear within 5 minutes. (not more than 40 ppm as sulfur dioxide)

Residue on Ignition The residue should not be more than 1 mg when placing 5 g sulfuric acid on platinum or quartz dish, evaporating it under water and igniting it at 450 ~ 550°C until being same weight.

Assay Accurately weigh about 2 g of Sulfuric Acid, and add to 50 mL of water. After cooling, add water to make exactly 100 mL. Take 25 mL of this solution, and titrate with 0.5 N sodium hydroxide (indicator : 1 ~ 2 drops of bromothymol blue solution).

1 mL of 0.5 N sodium hydroxide = 24.52 mg of H₂SO₄

Tagetes Extract

INS No.: 161b(ii)

Definition Tagetes Extract is a pigment that is obtained by extracting flowers of marigold of chrysanthemum family (*Tagetes erecta* WILLD.) with hexane. Its major colouring component is lutein of carotenoids and lutein dipalmitate. Dilutant, stabilizer, or solvent can be added for the purpose of color value adjustment and quality preservation.

Compositional Specifications of Tagetes Extract

Content Color value ($E_{1cm}^{10\%}$) of Tagetes Extract should not be less than declared value.

Description Tagetes Extract is orange yellow ~ yellowish brown liquid, lump, or paste with characteristic scent.

Identification (1) The solution, which Ethyl alcohol : n-Hexan (1:1) is added and dissolved in tagetes extract, exhibits maximum absorption at 469 ~ 475 nm and 441 ~ 447 nm. It exhibits maximum absorption at 420 ~ 426 nm in some cases.

(2) The solution, which tagetes extract is dissolved in acetone, becomes colorless when 5% sodium nitrite and 0.5M sulfuric acid solution are added in order.

Purity (1) Arsenic : It should be no more than 4.0 ppm tested by Arsenic Limit Test.

(2) Lead : When 5.0 g of tagetes extract is tested by Atomic Absorption Spectrophotometry or Inductively Coupled Plasma Emission Spectroscopy, its content should not be more than 2.0 ppm.

(3) Residual Solvent : When Tagetes Extract is tested by Purity (4) for 「Paprika Extract Pigments」, residual hexane should not be more than 25 ppm.

Assay(color value) Appropriate amount of Tagetes Extract is accurately weighed so that the absorbance is within 0.3 ~ 0.7 and dissolved in hexane (total volume 100 mL). 1 mL of this solution is diluted to 100 mL with hexane (Test Solution). If necessary, the solution is centrifuged and the supernatant is used. Using ethanol : hexane(1:1) as a reference solution, absorbance A is measured at the maximum absorption at 441~447 nm with 1 cm path length. Color value is obtained using the following equation.

$$\text{Color Value } (E_{1cm}^{10\%}) = \frac{A \times 1,000}{\text{weight of the sample(g)}}$$

Talc

INS No.: 553(iii)

Synonyms: Talcum

CAS No.: 14807-96-6

Definition Talc is purified from natural hydrated magnesium silicate. It may contain small amount of aluminum silicate.

Compositional Specifications of Talc

Description Talc is odorless and white ~ greyish white crystalline powder with a slippery touch.

Identification 0.2 g of Talc is mixed with 0.9 g anhydrous sodium carbonate and 1.3 g of anhydrous potassium carbonate. It is then heated until it melts completely in a platinum or nickel crucible. After cooling, it is transferred into a beaker with approximately 5 mL of hot water. Hydrochloric acid is slowly added until foaming stops. After adding 10 mL of hydrochloric acid, it is evaporated to dryness. After cooling, 20 mL of water is added to the residue, which is boiled and filtered. Gel phase residue on the filter paper. When the filtrate shows the reaction of Magnesium Salts in Identification.

Purity (1) Water-soluble substances and pH : 10 g of Talc is added to 100 mL of water. It is then heated for 2 hours while adding water to supplement the loss and shaking occasionally. After cooling, it is filtered using a Millipore filter. If the filtrate is turbid, it is filtered again through the same filter. The beaker and the filter is washed with water, which is added to the filtrate. The total volume of the filtrate is brought up to 100 mL with water. Use this solution as the test solution. pH of the test solution should be 7.5~9.5. 50 mL of the test solution is evaporated to dryness, which is then dried for 2 hours at 105°C. The weight of residue does not exceed 10 mg.

(2) Hydrochloric acid soluble substances : 1 g of Talc is mixed with 20 mL of diluted hydrochloric acid, which is stir-mixed and heated for 15 minutes at 50°C. After cooling, it is filtered. The beaker and the residue on the filter is washed with water, which is added to the filtrate. The total volume of the filtrate is brought up to 20 mL with water. 1 mL of diluted sulfuric acid is added to 10 mL of the filtrate, which is evaporated to dryness and heat treated at 550°C until the weight becomes constant. The residue does not exceed 10mg.

(3) Arsenic : It should be no more than 4.0 ppm tested by Arsenic Limit Test.

(4) Water-soluble iron : 20 mL of test solution in (1) is slightly acidified with hydrochloric acid. When 1 drop of potassium ferrocyanide solution is added to this solution, the solution does not turn blue.

(5) Lead : Accurately weigh 5 g of Talc, add 40 mL of diluted hydrochloric acid and 50 mL of water, mix well, mildly heat, cool, then filter. Wash the residue on the filter paper, combine the rinsings to the filtrate, then make up to 250 mL with water. Take 125 mL of this solution, evaporate to dry in the water bath, add 10 mL of diluted hydrochloric acid(1→10) to the residue, and make up to 10 mL, test solution. Separately, pipette 1 mL of lead standard solution, add diluted hydrochloric acid(1→10), then make up to 20 mL, reference solution. When test solution and reference solution are tested by flame

Atomic Absorption Spectrophotometry under following operation condition, the absorbance of test solution should not be higher than that of reference solution (not more than 2.0ppm).

Operation Condition

Light source lamp : lead cathode lamp

Analysis curve wavelength : 283.3nm

Combustible support gas : air

Combustible gas : acetylene

(6) Asbestos : Proceed test as directly under following (A) or (B), asbestos should not be detected. When asbestos is detected in the test by following (A) or (B), additionally test by (C), and asbestos should not be detected.

(A) Asbestos is measured by Potassium Bromide Disk Method in Infrared Spectrophotometry, absorption is identified at $600 \sim 650\text{cm}^{-1}$ (serpentine) or $757 \sim 759\text{cm}^{-1}$ (amphibole) of wave number. When absorption peak is at wave number $757 \sim 759\text{cm}^{-1}$, a certain amount of sample is ignited for 30 minutes at 850°C , cooled, again proceed under Infrared Spectrophotometry, and identify the absorption peak at wave number $757 \sim 759\text{cm}^{-1}$ which indicates tremolite in amphibole.

(B) When powder diffraction of Talc is measured with Powder X-Ray Diffractometer under following operation condition, the angle of diffraction 2θ identifies diffraction peak of $10.4 \sim 10.6^{\circ}$ (amphibole), $24.2 \sim 24.4^{\circ}$, and $12.0 \sim 12.2^{\circ}$ (serpentine).

Operation condition

X-ray light source : Cu $K\alpha$ monochromator

Tube current and tube voltage : 24 ~ 30mA, 40kV

Incidence angle : 1°

measurement angle : 0.2°

Scanning speed : $0.1^{\circ}/\text{minute}$

Scanning range (angle of diffraction 2θ) : $10 \sim 13^{\circ}$, $24 \sim 26^{\circ}$

(C) Observe form and color of asbestos with optical microscope, asbestos is confirmed if the following criteria are met:

- ① The ratio of length and width of fiber is in the range of 20:1 to 100:1 or when the length of fiber is longer than $5 \mu\text{m}$, the ratio of length and width is not less than 100:1.
- ② It can be split into very thin microfibers.
- ③ if 2 or more of the following 4 criteria are met:
 - Ⓐ parallel fibers occurring in bundles
 - Ⓑ fiber bundles displaying worn or frayed ends
 - Ⓒ fibers in the form of thin needles

Ⓓ matted masses of individual fibres and/or fibres showing curvature

Loss on Drying When Talc is dried for 1 hour at 105°C, the weight loss should not be more than 0.5%.

Loss on Ignition When loss on Ignition is done, weight loss should not be more than 6%.

Tamarind Color

Definition Tamarind Color is obtained by roasting and extracting with water from tamarind seeds (*Tamarindus indica* L. of leguminosae, a bean family). Its major pigment component is flavonoid. Dilutant, stabilizer, or solvent can be added for the purpose of color value adjustment and quality preservation.

Compositional Specifications of Tamarind Color

Content Color value ($E_{1cm}^{10\%}$) of Tamarind Color should be higher than the indicated value.

Description Tamarind Color is reddish brown ~ blackish brown liquid, lump, powder, or paste with a slight characteristic odor.

Identification (1) Test Solution obtained in Color Value section of Tamarind Color shows reddish brown.

(2) 0.5 g of Tamarind Color is dissolved in 100 mL of water. When 10 mL of this solution is acidified with 1 mL of hydrochloric acid, reddish brown precipitate is formed.

(3) 0.5 g of Tamarind Color is dissolved in 100 mL of water. When 2 mL of ferric chloride solution (1→50) is added to 10 mL of this solution, blackish brown precipitate is formed.

Purity (1) Arsenic : It should be no more than 4.0 ppm tested by Arsenic Limit Test.

(2) Lead : When 5.0 g of Tamarind Color is tested by Atomic Absorption Spectrophotometry or Inductively Coupled Plasma Emission Spectroscopy, its content should not be more than 10.0 ppm.

Assay (Color Value) Appropriate amount of Tamarind Color is precisely weighed so that the absorbance is within 0.3 ~ 0.7 and dissolved in acetic acid.sodium acetate buffer solution with pH 7.0 so that total volume is 100 mL (Test Solution). If necessary, the solution is centrifuged and the supernatant is used. Using acetic acid.sodium acetate buffer solution with pH 7.0 as a reference solution, absorption A is measured at the maximum absorbance at 500 nm with 1 cm cell. Color value is obtained using the following equation.

$$\text{Color Value}(E_{1cm}^{10\%}) = \frac{A \times 10}{\text{weight of the sample(g)}}$$

• Citric acid.dibasic sodium phosphate buffer solution (pH 7.0)

Solution 1 : 0.1M citric acid solution : 1L of solution containing 21.01 g of citric acid ($C_6H_8O_7 \cdot H_2O$).

Solution 2 : 0.2M dibasic sodium phosphate solution : 1L of solution containing 71.63 g of dibasic sodium phosphate ($Na_2HPO_4 \cdot 12H_2O$).

Solution 1 and Solution 2 are mixed well (35:165) and its pH is adjusted to 7.0.

Tamarind Gum

Synonyms: Tamarind seed polysaccharide

CAS No.: 39386-78-2

Definition Tamarind Gum is obtained from tamarind (*Tamarindus indica* LINNE) seeds and major component is polysaccharide. Dilutant can be added for the purpose of quality preservation.

Compositional Specifications of Tamarind Gum

Description Tamarind Gum is brownish gray- white powder having a slight odor.

Identification (1) 1 g of Tamarind Gum is dissolved in 100 mL of water at 80°C by stirring vigorously.

When it is cooled to room temperature, it becomes slightly turbid and viscous neutral liquid. When 3 mL of saturated sodium sulfate solution is added to 5 mL of this liquid, it becomes a jelly phase.

(2) 1 g of Tamarind Gum is slowly added and dissolved in 100 mL of 50% sugar solution at 80°C by stirring vigorously. After boiling carefully for 5 minutes, and then allowed to stand. It becomes solid of jelly phase.

Purity (1) Arsenic : It should be no more than 2.0 ppm tested by Arsenic Limit Test.

(2) Lead : When 5.0 g of Tamarind Gum is tested by Atomic Absorption Spectrophotometry or Inductively Coupled Plasma Emission Spectroscopy, its content should not be more than 10.0 ppm.

(3) Starch : 0.1 g of Tamarind Gum is dissolved in 10 mL of water, which is heated and then cooled. When 2 drops of iodine solution are added, it should not turn blue.

(4) Protein : When approximately 0.5 g of Tamarind Gum is tested as directed in Kjeldahl Method under Nitrogen Determination, the amount should not be more than 3%. (Protein Factor : 5.7).

(5) Crude Fat : 10 g of Tamarind Gum is precisely weighed into a cylindrical filter paper (Thimble Filter) and dried for 3 hours at 105°C. It is then extracted for 20 hours using a soxhlet extractor in a water bath. Then remove ether from the extract, and dried for 2 hours at 105°C. The content of crude fat should not be more than 1%.

Loss on Drying When 3 g of Tamarind Gum is dried for 3 hours at 100°C, the weight loss should not be more than 7%.

Ash 1 g of Tamarind Gum is tested for ash. The amount should not be more than 5%.

Tannase

Definition Tannase is the enzyme, which is obtained from the culture of *Aspergillus oryzae*. Diluent or stabilizer can be added for the purpose of activity adjustment and quality preservation.

Compositional Specifications of Tannase

Description Tannase is a white ~ pale brown powder, granule, paste or colorless ~ pale brown liquid with a characteristic scentless or a characteristic scent.

Identification When Tannase is proceeded as directed under Activity Test, it should have the activity as Tannase.

Purity (1) Arsenic : It should be no more than 4.0 ppm tested by Arsenic Limit Test.

(2) Lead : When 5.0 g of Tannase is tested by Atomic Absorption Spectrophotometry or Inductively Coupled Plasma Emission Spectroscopy, its content should not be more than 5.0 ppm.

(3) Coliform Group: Tannase is tested by Microbiological Method for [Coliform Group] in General Testing Methods in 「Standards and Specifications for Foods」. It should contain not more than 30 per 1g of this product.

(4) Salmonella : Tannase is tested by Microbiological Method for Salmonella] in General Testing Methods in 「Standards and Specifications for Foods」. It should be negative(-).

(5) E. Coli : When Tannase is tested by Microbe Test Methods for E. Coli in General Test Method 「Standards and Specifications for Foods」, it should be negative (-).

Activity Test (activity) Analysis Principle: The activity test is based on the hydrolysis of depside bond of tannin acid substrate at 30°C. Absorbance difference is measured by using spectrophotometer at 310nm. The preparation of Test Solution : When Tannase is weighted, 1 mL of the final diluent solution contains 1 Tannase unit. 50mM of citric acid buffer solution(pH 5.5) of the low temperature(5±3°C) is added to prepare Test solution.

Test Procedure : 4mL of substrate solution is added to a 25 × 150mm test tube and isothermalized for 10 minutes in a 30°C water bath. Precisely 1mL of Test solution is added to the test tube, and mixed well, and the reaction of the solution is conducted in a water bath(Reaction start). The test tube is separated with reaction solution A and B. After 10minutes from reaction start, 1mL of the reaction solution is taken in test tube A, and 9mL of 80% ethyl alcohol solution is added in the solution. Next, shake strongly and stop the reaction. This reaction solution is called as Solution A. After 20minutes from reaction start, 1mL of the reaction solution is taken in test tube B, and 9mL of 80% ethyl alcohol solution is added in the solution. Next, mix and stop the reaction. This reaction solution is called as Solution B. Solution A and B is diluted 10times by 80% ethyl alcohol, and these solutions are called as Enzyme test solution A and B. As control solution is 80% ethyl alcohol, each 1cm liquid layer of Enzyme test solution A and B, absorbance a and b, is measured at 310nm. The activity of the enzyme is calculated following the formula.

$$\text{Tannase unit/g} = \frac{(a - b) \times 20.3 \times 4}{\text{}}$$

$$10 \times 0.71 \times C$$

20.3 : μmol of tannic acid contained 1.0mL of substrate solution

4: Substrate solution for reaction(mL)

10: The difference between final and initial reaction time(min)

0.71: Absorbance change in the completed hydrolysis of tannic acid 20.3 μmol under above condition.

C: Sample amount containing in 1mL of the Test Solution(g)

a: Absorbance of Enzyme test solution A

b: Absorbance of Enzyme test solution B

Only, the value of (a-b) should be 0.09 ~ 0.11

Definition of Activity : 1 Tannase unit corresponds to the amount of enzyme, which hydrolyze 1 μmol of tannic acid per minutes under the above test conditions

Solutions

50mM citric acid buffer solution(pH 5.5)

Solution A : 10.5g of citric acid dissolve in 1000mL water.

Solution B : 14.7g of sodium citrate(2 hydrate) dissolve in 1000mL water.

A solution and B solution are mixed (138mL :500mL) and adjust pH to 5.5 with using both solutions.

Substrate solution : 0.32g of tannic acid (Sigma USP Grade) is weighted, and added in 10mL of 50mM citric acid(pH 5.5). Dissolve with warming and shaking. Add 50mM citric acid(pH 5.5) to make 100mL volume.

Storage standard of Tannase

Tannase should be stored in a hermetic container in a cold dark place.

Tannic Acid

INS No.: 181

Synonyms: Gallotannic acid; Tannins

CAS No.: 1401-55-4

Definition Tannic Acid is usually obtained from gallnut.

Compositional Specifications of Tannic Acid

Description Tannic Acid is yellowish white ~ pale brown amorphous powder, glistening scale shaped or spongy mass, odorless or with a faint, characteristic odor and astringent taste.

Identification (1) 1 g of Tannic Acid is dissolved 10 mL of water. When a small amount of ferric chloride solution is added, a bluish black colour or precipitate is formed.

(2) When alkaloid salts, albumin, or gelatin solution is added to the Test Solution obtained in (1), precipitate is formed.

Purity (1) Arsenic : It should be no more than 4.0 ppm tested by Arsenic Limit Test.

(2) Lead : When 5.0 g of Tannic Acid is tested by Atomic Absorption Spectrophotometry or Inductively Coupled Plasma Emission Spectroscopy, its content should not be more than 2.0 ppm.

(3) Residual Solvent : 1g of Tannic Acid is precisely weighed into a sample vial, 5µl of water is added, and seal it quickly with a septum, test solution. Proceed headspace-gas chromatography under operation conditions below and measure each amount of acetone and ethyl acetate from each calibration curve, it should be not more than 25ppm as individual or sum if used together

Operation Condition

Column : HP-1 or its equivalent

Detector : Hydrogen Flame Ionization Detector (FID)

Injection Port Temperature : 110°C

Column Temperature : 40°C

Detector Temperature : 110°C

Carrier gas : Nitrogen or helium

Head space sampler

Heating temperature : 80°C

Heating time : 40 minutes

Sample gas injection : 0.4mL

Mixed standard solution : 1 g of acetone and 1 g of ethyl acetate is precisely weighed into each flask, water is added to make 100 mL. 2, 20, 40 mL each of this solution is taken, water is added to make 100 mL, each mixed standard solution. (1 mL of each mixed standard solution contains 200, 2,000,

4,000µg of acetone and ethyl acetate, respectively).

Preparation of calibration curve : 1 g of tannic acid, free of acetone and ethyl acetate, is precisely weighed into a vial, 5µl each of 200, 2,000, 4,000ppm of mixed standard solution is added respectively, and seal it quickly with a septum. Proceed headspace-gas chromatography under operation conditions below and measure the peak area of acetone and ethyl acetate. From the peak area, prepare each calibration curve.

(4) Gums or Dextrins : 1 g of Tannic Acid is dissolved in 5 mL of water, which is then filtered. When 10 mL of alcohol is added to the filtrate, no turbid is produced within 15 minutes.

(5) Resinous substances : 1 g of Tannic Acid is dissolved in 5 mL of water, which is then filtered. When the filtrate is diluted to 15 mL with water, no turbid is produced

Loss on Drying When 3 g of Tannic Acid is dried for 2 hours at 105°C, the weight loss should not be more than 12%.

Residue on Ignition When Residue on Ignition is done with 1 g of Tannic Acid, the amount of residue should not be more than 1%.

Tara Gum

INS No.: 417

Synonyms: Peruvian carob

CAS No.: 39300-88-4

Definition Tara Gum is a polysaccharide obtained by grinding endosperm of tara (*Caesalpinia spinosa* Kuntze) seeds of actinidiaceae.

Compositional Specifications of Tara Gum

Description Tara Gum is nearly odorless, white ~ pale yellow powder.

Identification (1) When a small amount of sodium borate is added to an aqueous solution of Tara Gum, a gel is formed.

(2) 2 g of Tara Gum is placed in a 400 mL beaker. It is then moisten thoroughly with about 4 mL of isopropyl alcohol. With vigorous stirring, 200 mL of water is added and further stirred until the gum is completely and uniformly dispersed. 100 mL of this solution is transferred into another 400 mL beaker, which is heated for 10 minutes in a water bath. When it is cooled to room temperature, the solution shows a marked increase in viscosity.

Purity (1) Arsenic : It should be no more than 4.0 ppm tested by Arsenic Limit Test.

(2) Lead : When 5.0 g of Tara Gum is tested by Atomic Absorption Spectrophotometry or Inductively Coupled Plasma Emission Spectroscopy, its content should not be more than 2.0 ppm.

(3) Cadmium : When 5.0 g of Tara Gum is tested by Atomic Absorption Spectrophotometry or Inductively Coupled Plasma Emission Spectroscopy, its content should not be more than 1.0 ppm.

(4) Mercury : When 0.1 g of Tara Gum is tested by Mercury Test Method, its content should not be more than 1.0ppm.

(5) Starch : 0.1 g of Tara Gum is dissolved in 10 mL of water, which is heated and then cooled. When 2 drops of iodine solution are added, it should not produce blue.

(6) Protein : When 0.2 g of Tara Gum is precisely weighed and tested as directed in Kjeldahl Method under Nitrogen Determination, the amount should not be more than 3.5%. (Protein Factor : 6.25).

(7) Acid Insoluble substances : 0.5 g of Tara Gum is precisely weighed and dissolved in 150 mL of water and 1.5 mL sulfuric acid in a beaker, which is covered with a watch glass and heated for 6 hours in a water bath. Beaker wall is washed with water so that sample is not left on the wall. 500 mg of appropriate filtering aid is added to the filter, previously make a constant weight . The residue is washed thoroughly with hot water and dried for 3 hours at 105°C. It is subtracted the weight of the filtering aid from the weight of the residue, the amount should not be more than 2%.

Loss on Drying When Tara Gum is dried for 5 hours at 105°C, the weight loss should not be more than 15%.

Ash When Tara Gum is tested as indicated under ash, the amount should not be more than 1.5%.

DL-Tartaric Acid

dl-Tartaric Acid

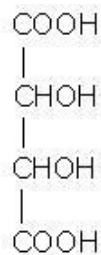

Chemical Formula: $\text{C}_4\text{H}_6\text{O}_6$

Molecular Weight: 150.09

Synonyms: 2,3-Dihydroxysuccinic acid

CAS No.: 133-37-9

Compositional Specifications of DL-Tartaric Acid

Content DL-Tartaric Acid, when calculated on the dried basis, should contain not less than 99.5% of DL-tartaric acid ($\text{C}_4\text{H}_6\text{O}_6$).

Description DL-Tartaric Acid occurs as colorless crystals or white crystalline powder. It is odorless and has an acid taste.

Identification (1) DL-Tartaric Acid solution (1→10) has no optical rotation.

(2) Proceed as directed under Identification (2), (3), and (4) in L-Tartaric acid.

Purity (1) Melting Point : Melting point of DL-Tartaric Acid should be within a range of 200 ~ 206°C

(2) Sulfate : Proceed as directed under Purity (2) in [L-Tartaric Acid].

(3) Arsenic : It should be no more than 4.0 ppm tested by Arsenic Limit Test.

(4) Lead : When 5.0 g of DL-Tartaric Acid is tested by Atomic Absorption Spectrophotometry or Inductively Coupled Plasma Emission Spectroscopy, its content should not be more than 2.0 ppm.

(5) Readily Oxidizable Substances : Dissolve 1.0 g of DL-Tartaric Acid in 25 mL of water and 25 mL of diluted sulfuric acid. Add 4.0 mL of 0.1 N potassium permanganate, keeping the solution at 20°C. The pink color of the solution does not disappear within 3 minutes.

Loss on Drying When DL-Tartaric Acid is dried for 3 hours in a vacuum desiccator (silica gel), the loss should not be more than 0.5%.

Residue on Ignition Proceed as directed under Residues on Ignition in [L-Tartaric Acid].

Assay Proceed as directed under Assay in [L-Tartaric Acid].

L-Tartaric Acid

d-Tartaric Acid

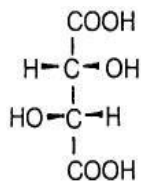

Chemical Formula: $\text{C}_4\text{H}_6\text{O}_6$

Molecular Weight: 150.09

INS No.: 334

Synonyms: L-2,3-Dihydroxysuccinic acid

CAS No.: 87-69-4

Compositional Specifications of L-Tartaric Acid

Content L-Tartaric Acid, when calculated on the dried basis, should contain not less than 99.7% of L-tartaric acid ($\text{C}_4\text{H}_6\text{O}_6$).

Description L-Tartaric Acid occurs as colorless and transparency crystals or as a white, fine crystalline powder. It is odorless and has an acid taste.

Identification (1) L-Tartaric Acid solution (1→10) is dextrorotatory.

(2) When L-Tartaric Acid is slowly heated, an odor that is similar to burning sucrose is generated.

(3) L-Tartaric Acid solution (1→10) is acidic.

(4) L-Tartaric Acid responds to the test for Tartrate in Identification.

Purity (1) Specific Rotation : Dissolve 2 g of L-Tartaric Acid, previously dried and accurately weighed in water to make 10 mL. Optical rotation of this solution should be within a range of $[\alpha]_D^{25} = +12.0 \sim +13.0^\circ$

(2) Sulfate : When 0.5 g of L-Tartaric Acid is tested by Sulfate Limit Test, its content should not be more than the amount that corresponds to 0.5 mL of 0.01 N sulfuric acid.

(3) Oxalate : Dissolve 1.0 g of L-Tartaric Acid in 10 mL of water, and add 2 mL of calcium chloride solution. No turbidity appears.

(4) Arsenic : It should be no more than 4.0 ppm tested by Arsenic Limit Test.

(5) Lead : When 5.0 g of L-Tartaric Acid is tested by Atomic Absorption Spectrophotometry or Inductively Coupled Plasma Emission Spectroscopy, its content should not be more than 2.0 ppm.

(6) Mercury : When L-Tartaric Acid is tested by Mercury Limit Test, its content should not be more than 1.0 ppm

Loss on Drying When L-Tartaric Acid is dried in a desiccator (silica gel) for 3 hours, the loss should not be more than 0.5%.

Residue on Ignition When thermogravimetric analysis is done with 2 g of L-Tartaric Acid, the amount of residues should not be more than 0.1%.

Assay Dissolve about 1.5 g of L-Tartaric Acid, previously dried and accurately weighed in water to make

exactly 250 mL. Take 25 mL of this solution, and titrate with 0.1 N sodium hydroxide (indicator : 2 ~ 3 drops of phenolphthalein solution).

1 mL of 0.1 N sodium hydroxide = 7.504 mg of $C_4H_6O_6$

Taurine

Chemical Formula: $C_2H_7NO_3S$

Molecular Weight: 125.14

CAS No.: 107-35-7

Compositional Specifications of Taurine

Content Dried material should contain not less than 99.0% of Taurine ($C_2H_7NO_3S = 125.14$).

Description Taurine is white crystalline powder. It is odorless.

Identification (1) When 5 drops of diluted hydrochloric acid and 5 drops of sodium nitrite solution are added to 5 mL of Taurine solution (1→20), bubbles are formed and colorless gas is generated.

(2) 7.5 mL of Sodium hydroxide solution is added to 0.5 g of Taurine, which is slowly heated to evaporate and then decomposed for 2 hours at 500°C. 5 mL of water is added to the residue, where 1 drop of nitroprusside sodium solution. Then the solution becomes violet red.

Purity (1) Clarity and Color of Solution : When 0.5 g of Taurine is dissolved in 20 mL of water, the solution is colorless.

(2) Chloride : When 1.0 g of Taurine is tested by Chloride Limit Test, its content should not be more than the amount that corresponds to 0.3 mL of 0.01 N hydrochloric acid.

(3) Sulfate : When 1.5 g of Taurine is tested by Sulfate Limit Test, its content should not be more than the amount that corresponds to 0.45 mL of 0.01 N sulfuric acid.

(4) Ammonia : 0.1 g of Taurine is dissolved in 70 mL of water in a flask, where 1 g of magnesium oxide is added and a distillation apparatus is attached. To a receiving flask, 2 mL of 0.1 N hydrochloric acid is added. Tip of the condenser is submerged in the solution. It is distilled until collected the distillate up to 40 mL. 5 mL of sodium hydroxide and water are added to make 50 mL solution. When 0.5 mL of Nestle solution is added, its color should not be deeper than the color standard (Use 2 mL of ammonia standard solution, with 5 mL of sodium hydroxide solution and water to make 50 mL, and 0.5 mL of nestle solution is added. Standard solution is prepared by the same procedure).

(5) Arsenic : It should be no more than 1.0 ppm tested by Arsenic Limit Test.

(6) Lead : When 5.0 g of Taurine is tested by Atomic Absorption Spectrophotometry or Inductively Coupled Plasma Emission Spectroscopy, its content should not be more than 2 ppm.

(7) Readily Carbonizable Substances : When 0.1 g of Taurine is tested by Readily Carbonizable Substances Test, the color should not be deeper than that of color standard S.

(8) Coliform Group : Taurine is tested by Microbe Test Methods for [Coliform Group] in General Test Methods in Food Code. It should be not more than 30 per 1 g of this product.

(9) Number of General Germs : When Taurine is tested by Total Viable Aerobic Count in General Test Method in Food Code, it should not be more than 1,000 per 1 g.

Loss on Drying When Taurine is dried for 2 hours at 105°C, the weight loss should not be more than

0.2%.

Residue on Ignition When thermogravimetric analysis is done with 1 g of Taurine, the amount of residues should not be more than 0.1%.

Assay Dissolve 0.2 g of Taurine, precisely dried and accurately weighed, in 50 mL of water, add 5 mL of formalin. It is then titrated with 0.1 N sodium hydroxide solution (indicator : 3 drops phenolphthalein solution). Separately, a blank test is carried out by the same method.

$$\text{Content(\%)} = \frac{12.514 \times (a-b)}{\text{weight of the sample(mg)}} \times 100$$

a : Consumed amount of 0.1 N sodium hydroxide solution for the test (mL)

b : Consumed amount of 0.1 N sodium hydroxide solution for the blank test (mL)

Tea Catechin

Definition Tea Catechin is obtained by extracting from leaves or stems of *Camellia sinensis* O. KZE with water or ethyl alcohol and then purifying, or by extracting them with hot water and then separating with methanol or ethyl acetate, and its main ingredient is catechin.

Composition Specifications of Tea Catechin

Content Tea Catechin, when calculated on the anhydrous basis, should be 70~110% as catechin.

Description Tea Catechin is a white, pale yellow ~ dark brown powder, paste, or liquid with characteristic smell.

Identification (1) When 0.1 g of Tea Catechin dissolve in 10 mL of 50% ethyl alcohol and 2 ~ 3 drops of ferric chloride (1→50) are added, the solution becomes greenish purple ~ dark purple.

(2) The aqueous solution of Tea Catechin exhibits absorption maximum at a wavelength of 265 ~ 280 nm.

Purity (1) Arsenic : It should be no more than 4.0 ppm tested by Arsenic Limit Test.

(2) Lead : When 5.0 g of Tea Catechin is tested by Atomic Absorption Spectrophotometry or Inductively Coupled Plasma Emission Spectroscopy, its content should not be more than 10.0 ppm.

(3) Residual Solvent : 1g of Tea Catechin is precisely weighed into a sample vial, 5 μ l of water is added, and seal it quickly with a septum, test solution. Proceed headspace-gas chromatography under operation conditions below and measure each amount of acetone and ethyl acetate from each calibration curve, it should be not more than 50ppm as individual or sum if used together

Operation Condition

Column : HP-1 or its equivalent

Detector : Hydrogen Flame Ionization Detector (FID)

Injection Port Temperature : 110°C

Column Temperature : 40°C

Detector Temperature : 110°C

Carrier gas : Nitrogen or helium

Head space sampler

Heating temperature : 80°C

Heating time : 40 minutes

Sample gas injection : 0.4mL

Mixed standard solution : 1 g of acetone and 1 g of ethyl acetate is precisely weighed into each flask, water is added to make 100 mL. 2, 20, 40 mL each of this solution is taken, water is added to make 100 mL, each mixed standard solution. (1 mL of each mixed standard solution contains 200, 2,000, 4,000 μ g of acetone and ethyl acetate, respectively).

Preparation of calibration curve : 1 g of tannic acid, free of acetone and ethyl acetate, is precisely

weighed into a vial, 5µl each of 200, 2,000, 4,000ppm of mixed standard solution is added respectively, and seal it quickly with a septum. Proceed headspace-gas chromatography under operation conditions below and measure the peak area of acetone and ethyl acetate. From the peak area, prepare each calibration curve.

Loss on Drying When Tea Catechin is dried at 100°C for 2 hours, the weight loss should not be more than 5%. (However, this applies only to powder products).

Assay 0.5 g of sample is precisely weighted and water content(W%) is measured. The amount that corresponds to about 30 mg of catechin of Tea Catechin is weighted, to which water is added. If necessary, it is heated for dissolution. The volume is made precisely 100 mL by adding water. To 5 mL of this solution, 5 mL of ferrous tartarate solution is added and then phosphate buffer (pH 7.5) is added to make precisely 25 mL for the test solution. With water as reference solution, absorbance is measure at 540 nm. Separately, the standard solution containing 5, 10, 15, 20, 25 mg of ethyl gallate (standard) are made. Using 5 mL of each of these standard solution and water, the same procedure as the test solution is performed to generate color. Then at 540 nm, absorbance is measured to determine the standard curve. From the absorbance of the test solution and the standard curve, the content (mg) of catechin in 100 mL of the test solution is determined, according to the following formula.

$$\text{Catechin Content(\%)} = \frac{C \times 1.5 \times 100}{\text{Weight of the sample(mg)} \times (100 - W)} \times 100$$

C : Concentration (mg/100 mL) of ethyl gallate in the test solution obtained from the standard solution

1.5 : Absorption of Ethyl Gallate 1mg corresponds to the absorption of tea catechin 1.5 mg.

W : Water content (%)

Tea Extract

Definition Tea Extract is obtained by extracting tea leaves of *Camellia sinensis* O. KZE. of Theaceae with water or ethyl alcohol and its major component is catechin.

Compositional Specifications of Tea Extract

Content Tea Extract (converted to anhydrous) are more than 20% as catechin, and should be 90 ~ 120% of the marked amount.

Description Tea Extract is pale yellow to dark brown power, paste, or liquid with a slight characteristic scent.

Identification (1) 0.1 g of Tea Extract in 10 mL of 50% ethyl alcohol. When 2 ~ 3 drops of ferric chloride(1→50) are added to the solution, it becomes greenish purple ~ darkish purple appear.

(2) The aqueous solution of Tea Extract show a maximum absorption peak at 265 ~ 280 nm.

Purity (1) Arsenic : It should be no more than 4.0 ppm tested by Arsenic Limit Test.

(2) Lead : When 5.0 g of Tea Extract is tested by Atomic Absorption Spectrophotometry or Inductively Coupled Plasma Emission Spectroscopy, its content should not be more than 10.0 ppm.

Loss on Drying When Tea Extract is dried for 2 hours at 100°C, the weight loss should not be more than 5%. (For powder only).

Assay 0.5 g of the sample is previously weighted and the amount of water (W%) is measured beforehand.

(1) Green tea extract : The amount that corresponds to about 30 mg of catechin of Tea Extract is accurately weighted, to which water is added. If necessary, it is heated for dissolution. The volume is made precisely 100 mL by adding water. To 5 mL of this solution, 5 mL of ferrous tartarate is added and then phosphate buffer (pH 7.5) is added to make precisely 25 mL for the test solution. With the control solution being water, absorbance is measure at 540 nm. Separately, the standard solution containing 5, 10, 15, 20, 25 mg of ethyl gallate (standard) per 100 mL are made. Using 5 mL of each of these standard solution, the same procedure as the test solution is performed to generate color. Then at 540 nm, absorbance is measured to determine the standard curve. From the absorbance of the test solution and the standard curve, calculate the content (mg) of catechin in 100 mL of the test solution by the following formula.

$$\text{Catechin Content(\%)} = \frac{C \times 1.5 \times 100}{\text{weight of the sample(mg)} \times (100 - W)} \times 100$$

C : Concentration of ethyl gallate in the test solution obtained from the standard solution (mg/100mL)

1.5 : The absorbance of 1 mg of ethyl gallate corresponds to that of 1.5 mg of tea catechin.

W : Water content (%)

(2) Woorong tea and red tea extracts : The amount of Tea Extract that corresponds to about 10 mg of

catechin is weighted accurately and dissolved in 1 mL of 50% ethanol, and made precisely 100 mL by adding water. This is the test solution. Separately, about 25 mg of (+) catechin (for assay) that is dried at 100 °C for 1 hour is accurately weighted and dissolved in 1 mL of 50% ethanol, and made precisely 100 mL by adding water. 5, 7.5, 10, 12.5, and 15 mL of this solution are respectively taken and diluted precisely to 25 mL by adding water. These are the standard solutions. To 0.15 mL of each standard solution and the test solution, 1.35 mL of water and 0.5 mL of Folin-Denis's solution are added and mixed. As for the control solution of the test solution, 0.5 mL of water is used. After 3 mins, 1 mL of sodium carbonate (1→10) is added. Place in a thermostatic water bath of 30°C for 1 hour and measure the absorbance at 700 nm. The standard curve is made from the measured values of the standard solutions of (+) catechin. Calculate the content of catechin in 100 mL of the test solution. The content of catechin is determined by the following formula.

$$\text{Catechin Content(\%)} = \frac{C \times 100}{\text{weight of the sample(mg)} \times (100 - W)} \times 100$$

C : Concentration (mg/100 mL) ethyl gallate in the test solution obtained from the standard curve

W : Water content (%)

Solutions

- Folin-Denis's solution : Add 180 mL of water to 25 g of sodium tungstate, 5 g of phosphomolybdic acid, and 15.5 mL of phosphoric acid. Attach a reflux condenser, heat the solution gently for 2 hours. Cool the solution and add water to make 1,000 mL.

Thaumatococcus danienii

INS No.: 957

CAS No.: 53850-34-3

Definition Thaumatococcus danienii is obtained by purifying the water extracts of seeds of Thaumatococcus danienii Benth. Its component is Thaumatococcus danienii.

Compositional Specifications of Thaumatococcus danienii

Content When Thaumatococcus danienii is quantitatively analyzed, it should contain more than the amount indicated as thaumatococcus danienii.

Description Thaumatococcus danienii is scentless whitish ~ grayish brown powder, flakes, or solid with a cool and strong sweet taste.

Identification (1) Dissolve 0.1 g of Thaumatococcus danienii in 10 mL of sodium hydroxide solution by heating and cooled. When 0.5 mL of copper sulfate solution (1→100) is added to this solution, it becomes reddish violet ~ bluish green in color.

(2) 2 mL of buffer solution (ninhydrine/acetic acid) and 2 mL of hydrazine sulfate solution (0.26→500) are added to 2 mL aqueous solution of Thaumatococcus danienii (1→100). Upon heating a water bath, this solution turns bluish violet.

Standard Solution

• Ninhydrine/Acetic acid buffer solution : Dissolve 2 g of ninhydrine in 50 mL of water, where 25 mL of acetic acid buffer and water are added to bring up the total volume to 100 mL.

• Acetic acid buffer : Dissolve 82 g of anhydrous sodium acetate in 140 mL of water. 25 mL of acetic acid and water are added to bring up the total volume to 250 mL. By adding acetic acid or sodium acetate solution (2→15), pH of this solution is adjusted to pH 5.51 ± 0.03.

(3) The solution obtained in Assay has a maximum absorption band near 277 nm.

Purity (1) Arsenic : It should be no more than 2.0 ppm tested by Arsenic Limit Test.

(2) Lead : When 5.0 g of Thaumatococcus danienii is tested by Atomic Absorption Spectrophotometry or Inductively Coupled Plasma Emission Spectroscopy, its content should not be more than 3.0 ppm.

(3) Aluminium : When 5.0 g of Thaumatococcus danienii is tested by Atomic Absorption Spectrophotometry or Inductively Coupled Plasma Emission Spectroscopy, its content should not be more than 100 ppm.

(4) Carbohydrate : 0.2 g of Thaumatococcus danienii is precisely weighted, dissolved in water to make 100 mL, test solution. 0.2 mL of test solution is taken into a test tube made of glass, cooled in an ice water bath, 1.2 mL of Cysteine.sulfuric acid solution which is previously cooled in an ice water bath is added, with a stopper, shaken vigorously, and mixed. Test tube is set aside in an ice water bath for 2 minutes, at room temperature for 3 minutes, and heated for 3 minutes in boiling water. It is immediately immersed

in an ice water bath and set aside for 5 minutes. The absorption is measured at 412 nm wavelength with 1cm path length. Then the concentration of carbohydrate(as glucose) in test solution is calculated from calibration curve. The content of carbohydrate should not be more than 3.0%.

Content of Carbohydrate(%) =

$$\frac{\text{concentration of carbohydrate in test solution(as glucose, } \mu\text{g/mL)}}{\text{Weight of sample(g)} \times 1 - (\text{loss on drying}(\%)/100)} \times \frac{100}{10^6} \times 100$$

Preparation of calibration curve : Dissolve standard of glucose in water to prepare the concentration to 10 ~ 100 $\mu\text{g/mL}$. Calibration curve is prepared from the absorption measured by same procedure of test solution.

Solution

L-Cysteine Solution : Dissolve 3 g of Cysteine hydrochloric acid hydrate in water to make 100 mL.

Cysteine.sulfuric acid : Mix 0.5 mL of L-Cysteine solution and 25 mL of 86% sulfuric acid. This is prepared freshly before use.

(5) Total viable aerobic count : When Thaumatin proceed as directed under Total viable aerobic count for Coliform in General Testing Methods in 「Standards and Specifications for Foods」, it should not be more than 1,000 per 1 g.

(6) E. coli : When Thaumatin proceed as directed under Microbiological Methods for E. coli in General Testing Methods in 「Standards and Specifications for Foods」, it should be negative (-).

Loss on Drying When Thaumatin is dried for 5 hours at 105°C, the weight loss should not be more than 9%.

Ash After carbonizing at 500°C, Thaumatin tested by Ash and Acid-Insoluble Ash Limit. The amount of ash should not be more than 1.0%.

Residue on Ignition When Residue on Ignition is done with precisely weighed 5 g of Thaumatin, the amount of residue should not be more than 0.05%.

Assay Approximately 1 g of Thaumatin is precisely weighted and dissolved in water (total volume = 100 mL), which is then filtered through a filter paper. 5 mL of this solution is diluted 100 mL with water (Test Solution). Absorption A of Test Solution is measured at the maximum absorption near 277 nm with 1cm path length using water as a reference. The content is obtained by the following equation.

$$\text{Content}(\%) = \frac{A \times 100}{0.567 \times S}$$

S : Weight of sample (g)

L-Theanine

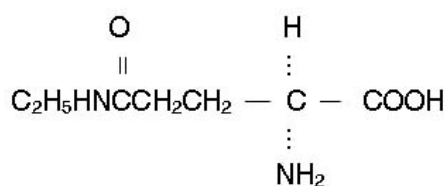

Chemical Formula: C₇H₁₄N₂O₃

Molecular Weight: 174.20

CAS No.: 3081-61-6

Compositional Specifications of L-Theanine

Content L-Theanine. when calculated on the dried basis, should contain within a range of 98.0 ~ 102.0% of L-theanine (C₇H₁₄N₂O₃).

Description L-Theanine occurs as a white crystalline powder. It is odorless and has a slightly characteristic and sweet taste.

Identification (1) To 5 mL of L-Theanine solution (1→1.000). add 1 mL of ninhydrin solution (1→1.000), and heat for 3 minutes. A purple color develops.

(2) Dissolve about 1 g of L-Theanine in 10 mL of diluted hydrochloric acid (1→2). equip with a reflux condenser, heat on a water bath for 6 hours, and add water to make 20 mL. Transfer 5 mL of this solution into a test tube, and add 2 g of sodium hydroxide. Suspend a red litmus paper moistened with water in the test tube, cover the mouth of the test tube, and heat in a water bath for 5 minutes. The color of the litmus paper changes to blue.

Purity (1) Clarity and Color of Solution : When 1 g of L-Theanine (Anhydrous) is dissolved in 20 mL of water, the solution should be colorless and almost clear.

(2) Specific rotation : Approximately 2.5 g of L-Theanine is precisely weighed, which is dissolved in water so that the total volume to make 50 mL. Optical rotation of the solution is measured. When it is translated to dried material, $[\alpha]_D^{20} = +7.7 \sim +8.5^\circ$

(3) pH : Approximately 1 g of L-Theanine is dissolved in water so that volume to make 100 mL. It should be within a range of 5.0~6.0.

(4) Chloride : When 0.5 g of L-Theanine is tested by Chloride Limit Test, the detected amount should not be more than the amount that corresponds to 0.30 mL of 0.01 N hydrochloric acid.

(5) Arsenic : It should be no more than 4.0 ppm tested by Arsenic Limit Test.

(6) Lead : When 5.0 g of L-Theanine is tested by Atomic Absorption Spectrophotometry or Inductively Coupled Plasma Emission Spectroscopy, its content should not be more than 2.0 ppm.

Loss on Drying When L-Theanine is dried 3 hours at 105°C, the weight loss should not be more than

0.5%.

Residue on Ignition When thermogravimetric analysis is done with L-Theanine, the residue should not be more than 0.2%.

Assay Approximately 0.35 g is precisely weighed and dissolved in 3 mL of formic acid, where 50 mL of glacial acetic acid (for non-aqueous titration) is added. This solution is titrated with 0.1 N perchloric acid solution (indicator : 1 mL of crystal violet buffered in glacial acetic acid). At the end point, the solution turns from violet to blue, then to green. Separately, a blank experiment is done following the same procedure.

1 mL of 0.1 N perchloric acid = 17.420 mg of $C_7H_{14}N_2O_3$

DL-Threonine

CH₃

CH

—

CHC

OO

H

□

□

OH

NH₂

Chemical

Formula:

C₄H₉O₃N

Molecula

r Weight:

119.12

Synonym

s

:

D

L

-

2 CAS

- No.:

A 80-

m 68-2

i

n

o

-

3

-

h
y
d
r
o
x
y
b
u
t
y
r
i
c
a
c
i
d

Compositional Specifications of DL-Threonine

Content DL-Threonine, when calculated on the dried basis, should contain within a range of 98.0 ~ 102.0% of DL-threonine (C₄H₉O₃N).

Description DL-Threonine occurs as white crystals or crystalline powder. It is odorless and has a slightly sweet taste.

Identification (1) DL-Threonine solution (1→25) has no optical rotation.

(2) To 5 mL of DL-Threonine solution (1→10), add 5 mL of potassium periodate and heat. A gas with an odor of ammonia is evolved, and it becomes the color of a red litmus paper wetted with water to blue.

(3) To 5 mL of DL-Threonine solution (1→1000), add 1 mL of ninhydrin solution. and heat for 3 minutes. A purple to red-purple color becomes.

Purity (1) Clarity and Color of Solution : When 1 g of DL-Threonine dissolved in 20 mL of water, the solution should be colorless and should not be more than almost clear.

(2) pH : pH of DL-Threonin solution (1→20) should be within a range of 5.0~6.5.

(3) Arsenic : It should be no more than 4.0 ppm tested by Arsenic Limit Test.

(4) Lead : When 5.0 g of DL-Threonine is tested by Atomic Absorption Spectrophotometry or Inductively Coupled Plasma Emission Spectroscopy, its content should not be more than 5.0 ppm.

(5) Allothreonine and Other Amino Acids : Weigh 0.1 g of DL-Threomne, and dissolve in water to make 50 mL. Use this solution as the test solution. Measure 0.005 mL of the test solution and proceed as directed under Paper Chromatography Method 1, using n-butanol, methyl ethyl ketone, ammonia solution, water mixture (5:3:1:1) as the developing solvent. Only one spot is observed. In the case, for the filter paper. use a No.2 filter paper for chromatography and stop the development when the developing solvent rises about 30 cm. Air-dry the filter paper and then dry at 100°C for 20 minutes, spray with a solution of 0.2% ninhydrin n-butanol, dry at 100°C for 5 minutes, and observe in daylight. Without using a reference solution.

(6) Chloride : When 0.5 g of DL-Threomne is proceeded as directed under chloride, its content should not be more than the amount that corresponds to 0.3 mL of 0.01 N hydrochloric acid.

Loss on Drying When DL-Threomne is dried for 3 hours at 105°C, the weight loss should not be more than 0.2%.

Residue on Ignition When thermogravimetric analysis is done with DL-Threomne, the amount of residues should not be more than 0.1%.

Assay Proceed as directed under Assay in 「Glycine」.

1 mL of 0.1 N perchloric acid = 11.91 mg of $C_4H_9NO_3$

L-Threonine

OH

H

: :

H₃C

—

C—

C—

COO

H

: :

H

NH₂

Chemical

Formula:

C₄H₉O₃N

Molecular

Weight:

119.12

Synonyms

:

L

-

2

CAS

-

No.:

A

72-

m

19-5

in

o

-

3

-
h
y
d
r
o
x
y
b
u
ty
ri
c
a
ci
d

Compositional Specifications of L-Threonine

Content L-Threonine, when calculated on the dried basis, should contain within a range of 98.0 ~ 102.0% of L-threonine (C₄H₉O₃N).

Description L-Threonine occurs as white crystals or crystalline powder. It is odorless and has a slightly sweet taste.

Identification (1) L-Threonine solution (1→25) has levorotatory.

(2) Proceed as directed under Identification and (2) and (3) in 「DL-Threonine」.

Purity (1) Clarity and Color of Solution : When 1 g of L-Threonine is dissolved in 20 mL of water, the solution should be colorless and should not be more than almost clear.

(2) pH : pH of L-Threonine solution (1→20) should be within a range of 5.0~6.5.

(3) Specific rotation : After drying for 3 hours at 105°C, approximately 3 g of L-Threonine is precisely weighed, which is dissolved in water to make 50 mL. Optical rotation of this solution should be within a range of $[\alpha]_D^{25} = -26 \sim -29^\circ$

(4) Arsenic : It should be no more than 4.0 ppm tested by Arsenic Limit Test.

(5) Lead : When 5.0 g of L-Threonine is tested by Atomic Absorption Spectrophotometry or Inductively Coupled Plasma Emission Spectroscopy, its content should not be more than 5.0 ppm.

(6) Allothreonine and other Amino Acids : Proceed as directed under Purity (5) in 「DL- Threonine」.

(7) Chloride : Proceed as directed under Purity (6) in 「DL- Threonine」.

Loss on Drying When DL- Threonine is dried for 3 hours at 105°C, the weight loss should not be more

than 0.2%.

Residue on Ignition When thermogravimetric analysis is done with DL-Threonine, the amount of residues should not be more than 0.1%.

Assay Proceed as directed under Assay in 「DL- Threonine」.

1 mL of 0.1 N Perchloric acid = 11.91 mg of $C_4H_9NO_3$

Titanium Dioxide

Chemical Formula: TiO_2

Molecular Weight: 79.90

INS No.: 171

Synonyms: CI pigment white 6; Titania

CAS No.: 13463-67-7

Compositional Specifications of Titanium Dioxide

Content Titanium Dioxide, when calculated on the dried basis, should contain not less than 99.0% of Titanium Dioxide (TiO_2).

Description Titanium Dioxide occurs as a white powder. It is odorless and tasteless.

Identification To 0.5 g of Titanium Dioxide, add 5 mL of sulfuric acid, and heat gently until fumes of sulfuric acid are evolved. Cool, add water gradually to make about 100 mL, filter, and add 2 ~ 3 drops hydrogen peroxide solution to 5 mL of the filtrate. The color becomes orange-red color.

Purity (1) Water-Soluble Substances : To 4 g of Titanium Dioxide, add 50 mL of water, shake, and allow to stand 24 hours, transfer into a 100 mL volumetric flask, add 2 mL of ammonium chloride solution, and shake. If a precipitate of titanium dioxide is not formed, add another 2 mL of ammonium chloride solution, and allow to stand. After the precipitate is formed, add water to make 200 mL, and filter while shaking. Discard 10 mL of the initial filtrate, transfer 100 mL of the subsequent filtrate into a platinum crucible previously weighed, evaporate to dryness, ignite to constant weight, and weigh the residue. The residue should not be more than 5 mg. (Not more than 0.25%)

(2) Hydrochloric Acid-Soluble Substances : Weigh 5 g of Titanium Dioxide, add 100 mL of diluted hydrochloric acid (1→20), shake, heat in a water bath for 30 minutes while stirring occasionally, and filter. Wash the residue three times with 10 mL of diluted hydrochloric acid (1→20) each time, combine the filtrate and the washings, evaporate to dryness, ignite to constant weight, and weigh the residue. The residue should not be more than 25 mg. (Not more than 0.5%)

(3) Arsenic : It should be no more than 1.3 ppm tested by Arsenic Limit Test.

(4) Lead : Transfer 10.0 g of Titanium Dioxide, previously dried and accurately weighed, into a beaker, and add 50 mL of 0.5 N hydrochloric acid. Cover it with a watch glass, boil for 15 minutes, and cool it down. Transfer it to 100~150 mL centrifuge tube and centrifuge it for 10~15 minutes until the insoluble substances are settled. Filter the supernatant through a filter paper (a Whatman No.4 filter paper or its equivalent) and transfer the filtrate to a 100 mL flask. To the residue, add 10~15 mL of hot water, mix, and centrifuge it. Filter the supernatant and add it to the filtrate. Repeat this preparation twice and add the solution to filtrate, dilute to 100 mL with water, test solution. When this test solution is tested by Atomic Absorption Spectrophotometry or Inductively Coupled Plasma Emission Spectroscopy, its content should not be more than 10 ppm.

- (5) Cadmium : When the test solution of (4) Purity is tested by Atomic Absorption Spectrophotometry or Inductively Coupled Plasma Emission Spectroscopy, its content should not be more than 1.0 ppm.
- (6) Antimony : When the test solution of (4) Purity is tested by Atomic Absorption Spectrophotometry or Inductively Coupled Plasma Emission Spectroscopy, its content should not be more than 2.0 ppm.
- (7) Zinc : When the test solution of (4) Purity is tested by Atomic Absorption Spectrophotometry or Inductively Coupled Plasma Emission Spectroscopy, its content should not be more than 50 ppm.
- (8) Mercury : When Titanium Dioxide is tested by Mercury Limit Test, its content should not be more than 1.0 ppm.
- (9) Aluminum Oxide and Silicon Dioxide : The total content of aluminum oxide and silicon dioxide determined by the following methods is not more than 2.0%.
- (i) Aluminum Oxide : Weigh 1 g of Titanium Dioxide and 10 g of sodium hydrogen sulfate, transfer into a quartz Erlenmeyer flask, and heat gently until completely fused. Cool, add 25 mL of diluted sulfuric acid (1→2). and heat carefully until the precipitate dissolves. Cool, and add water to make 120 mL. To the solution, add 65 mL of sodium hydroxide solution (1→4) while stirring, transfer gradually into a 500-mL volumetric flask containing 135 mL of sodium hydroxide solution (1→4) while stirring, and add water to make 500 mL. Allow to stand or centrifuge for 5 minutes. and filter. Transfer 100 mL of the filtrate into a 500-mL Erlenmeyer flask, add 1 drop of methyl orange solution, acidify with diluted hydrochloric acid (1→2), add 3 mL of diluted hydrochloric acid (1→2). And add 25 mL of 0.02 M EDTA exactly measured. Add drop wise ammonia solution until the color of the solution changes from red to orange-yellow, and add 10 mL of ammonium acetate buffer (77 g of ammonium acetate, add 10 mL of glacial acetic acid and add water to make 1,000 mL) and 10 mL of diammonium phosphate buffer (150 g of diammonium phosphate, add 700 mL of water and adjust to pH 5.5 with diluted hydrochloric acid (1→20) and add water to make 1,000 mL). It is boiled for 5 minutes and then cool rapidly in flow water. Add 3 drops of xylenol orange solution, and mixed. If the color of the solution changes to purple, yellow-brown, or pink, adjust the pH to 5.3 ~ 5.7 with acetic acid. if no pink color develops, use this solution as the test solution. if a pink color develops. repeat the above procedure with another 100-mL portion of the filtrate, using 50 mL of 0.02 M EDTA exactly measured. Use the resulting solution as the test solution. Add titrated 0.01 M zinc sulfate to the sample solution until the yellow-brown color of the solution becomes reddish (This persists for 5 ~ 10 seconds).

(Note: This titration should be carried out quickly. Near the end point, it is added by 0.2 mL until the color appears first. Even the color disappears in 5 ~ 10 seconds, it is regarded as the end point. If the observation of the first color change fails, it becomes an inaccurate titration. The consumption for the first color change should not be more than 8 mL. To be accurate, it should be 10 ~ 15 mL). Add 2 g of sodium fluoride, boil for 2 ~ 5 minutes, cool rapidly in flow water, titrate the liberated EDTA with 0.01 M zinc sulfate until the yellow-brown color of the solution becomes reddish, and

calculate the content by the following formula:

Content of aluminum oxide (Al_2O_3) (%) =

$$\frac{T \times \text{Weight of 0.01M zinc sulfate solution consumed in second titration (mL)}}{\text{weight of the sample (g)} \times 2}$$

In this case, T is calculated by the following method. It is the weight of aluminum oxide (mg) (Al_2O_3) corresponding to 1 mL of 0.01 M zinc sulfate.

• 0.01 M zinc sulfate solution : 2.9 g of zinc sulfate ($\text{ZnSO}_4 \cdot 7\text{H}_2\text{O}$) is dissolved in water to make 1,000 mL. 500 mg of aluminum (high purity, 99.0%) is precisely weighed and dissolved in 20 mL hydrochloric acid by gently heating. It is then diluted to 1,000 mL. 10 mL of this solution is transferred into a 500 mL Erlen Meyer flask with 90 mL of water and 3 mL of hydrochloric acid. 1 drop of methyl orange solution and 25 mL of 0.02 M EDTA solution are added and ammonia solution is added drop-wise until its red color turns orange yellow. After adding 10 mL of ammonium acetate buffer solution and 10 mL of diammonium phosphate buffer solution, it is boiled for 5 minutes and then quenched, where 3 drops of xylenol orange solution are added. Zinc sulfate solution is added until the yellow color becomes red. 2 g of sodium fluoride is added to the resulting solution, which is then boiled for 2 ~ 5 minutes and quenched. The free EDTA is titrated with this zinc sulfate solution until the yellow color becomes red. T is calculated from the following equation.

$$T = \frac{18.896 \times W}{V}$$

W : Weight of aluminum (g)

V : Weight of zinc sulfate solution consumed in second titration (mL)

$$18.896 = \frac{\text{Molecular weight of } \text{Al}_2\text{O}_3}{\text{Molecular weight of Al}} \times \frac{1,000\text{mg}}{\text{g}} \times \frac{10\text{mL}}{2}$$

(ii) Silicon Dioxide : Weigh 1.0 g of Titanium Dioxide and 10 g of sodium hydrogen sulfate, transfer into a platinum crucible, and heat gently until completely fused. Cool, add 25 mL of diluted sulfuric acid (1→2). heat carefully until the precipitate dissolves, cool, and add 150 mL of water gradually while shaking occasionally. Filter the solution through a filter paper for quantitative analysis (SC), wash the crucible with diluted sulfuric acid (1→2), and filter through the same filter paper. Transfer the filter paper into another platinum crucible. dry at 120°C, and ignite carefully at 450 ~ 550°C. Ignite at 1,000°C for 30 minutes, allow to cool in a desiccator, and Accurately weigh the total weight W(g). Add 2 drops of diluted sulfuric acid (1→2) and 5 mL of hydrofluoric acid, heat gradually and evaporate to dryness. ignite at 1,000°C for 30 minutes. allow to cool in a desiccator, Accurately weigh the total weight w (g), and calculate the content by the following formula :

$$\text{Content of silicon dioxide(SiO}_2\text{)(\%)} = \frac{W(\text{g}) - w(\text{g})}{\text{weight of the sample(g)}} \times 100$$

Loss on Drying When Titanium Dioxide is dried for 3 hours at 105°C, the weight loss should not be more than 0.5%.

Loss on Ignition When Titanium Dioxide is dried for 3 hours at 105°C and heat-treated at 775 ~ 825°C, the weight loss should not be more than 0.5% as anhydrous.

Assay Transfer about 0.2 g of Titanium Dioxide, previously dried and accurately weighed, into platinum crucible, add 2 g of sodium hydrogen sulfate, covered, and heat gently until completely fused. Ignite at a high temperature until the color turn to a deep orange to almost clear liquid. Cool, transfer the contents into a 250 mL beaker, wash the crucible with 75 mL of diluted sulfuric acid (1→30). transfer the washings into the beaker, and heat in a water bath until it dissolves and becomes almost clear. Dissolve 2 g of tartaric acid in the solution, add 2 ~ 3 drops of bromothymol blue solution, and neutralize with ammonia solution. If necessary filtered, and acidify with 1 ~ 2 mL of diluted sulfuric acid (1→2), pass an ample amount of hydrogen sulfide through it, add 30 mL of ammonia solution. Pass hydrogen sulfide through it until saturated, allow to stand for 10 minutes, filter, and wash the precipitate on the filter paper 10 times with 25 mL of mixture of ammonium tartrate solution(1→100) and ammonium sulfide solution (9:1). During filtering and washing, keep the filter paper immersed in the solution. Combine the filtrate and the washings. To this solution, add 40 mL of diluted sulfuric acid (1→2), boil until the hydrogen sulfide is removed, cool, and add water to make 400 mL. Add gradually 40 mL of cupferron solution while stirring, and allow to stand. After a yellow precipitate is formed, add cupferron IS until a white precipitate is formed. Filter the precipitate with light suction through a filter paper for quantitative analysis (SC), wash 20 times with diluted hydrochloric acid (1→10). and remove the water with slightly strong suction. Dry the precipitate together with the filter paper at 70°C, transfer into a crucible previously accurately weighed. heat very weakly until the fumes are not appear , ignite gradually. and then ignite at 900 ~ 950°C to constant weight. Cool. and weigh the amount of residue W (g). Using the values obtained in Purity (5), calculate the content by the following formula:

$$\frac{W(\text{g}) \times 100}{\text{Weight of the sample(g)}} \times \frac{100}{100 - \text{Content of aluminum oxide and silicon dioxide(\%)}}$$

Content of titanium dioxide (TiO₂)(%) =

***dl*- α -Tocopherol Acetate**

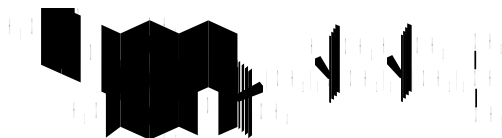

Chemical Formula: $C_{31}H_{52}O_3$

Molecular Weight: 472.75

CAS No.: 58-95-7

Compositional Specifications of *dl*- α -Tocopherol Acetate

Content *dl*- α -Tocopherol Acetate should contain not less than 96.0% of *dl*- α -Tocopherol ($C_{31}H_{52}O_3$).

Description *dl*- α -Tocopherol Acetate is colorless ~ yellow viscous liquid and odorless.

Identification 10 mg of *dl*- α -Tocopherol Acetate is dissolved in 10 mL of anhydrous ethyl alcohol, and 2 mL of nitric acid is added. After heating for 15 minutes at 75°C, the solution turns red ~ orange.

Purity (1) Refractive Index : Refractive Index n_D^{20} of *dl*- α -Tocopherol Acetate should be within a range of 1.494~1.499.

(2) Specific Gravity : Specific gravity of *dl*- α -Tocopherol Acetate should be within a range of 0.952~0.966.

(3) Clarity and Color of Solution : When 0.1 g of *dl*- α -Tocopherol Acetate is dissolved in 10 mL of anhydrous ethanol, the solution should be clear.

(4) Specific Absorbance : 10 mg of *dl*- α -Tocopherol Acetate is dissolved in anhydrous ethyl alcohol to make 100 mL. Absorbance is measured in a cell with 1 cm thickness at 284 nm. It should be a range of $E_{1cm}^{1\%} = 41.0\sim 45.0$.

(5) Arsenic : It should be no more than 2.0 ppm tested by Arsenic Limit Test.

(6) Lead : When 5.0 g of *dl*- α -Tocopherol Acetate is tested by Atomic Absorption Spectrophotometry or Inductively Coupled Plasma Emission Spectroscopy, its content should not be more than 2.0 ppm.

(7) α -Tocopherol : Accurately weigh about 1 g of *dl*- α -Tocopherol Acetate and proceed as directed under Assay in 「Vitamin E」. The content of α -Tocopherol should not be more than 0.5%.

(8) Acid Value : Dissolve 1 g of *dl*- α -Tocopherol Acetate in 25 mL of the 1:1 mixture of alcohol and ether neutralized with 0.1 N sodium hydroxide solution (indicator : phenolphthalein solution). Add 0.5 mL of phenolphthalein solution, and titrate with 0.1 N sodium hydroxide solution until a pale red color of the solution persists for 30 seconds. The consumed amount should not be more than 1.0 mL.

Assay Accurately weigh about 0.25 g of *dl*- α -Tocopherol Acetate, transfer into a 100 mL brown round bottom flask, add 25 mL of anhydrous ethyl alcohol and 20 mL solution of sulfuric acid in ethyl alcohol (3→20), and attach a reflux condenser to the flask. The solution is then boiled for 3 hours. After cooling, transfer the solution into a 200 mL brown mass flask, and add anhydrous ethyl alcohol to make 200 mL. Take 50 mL of this solution, add 50 mL solution of sulfuric acid in ethyl alcohol (3→200) and 20 mL

of water and proceed as directed under Assay in for 「Vitamin E」.

1 mL of 0.01 N ceric ammonium sulfate solution = 2.3638 mg $C_{31}H_{52}O_3$

d- α -Tocopherol Concentrate

Chemical Formula: C₂₉H₅₀O₂

Molecular Weight: 430.71

INS No.: 307a

Synonyms: RRR- α -Tocopherol concentrate;
5,7,8-trimethyltolcol

CAS No.: 59-02-9

Definition d- α -Tocopherol Concentrate is a form of vitamin E obtained from edible vegetable oil. Its major component is d- α -tocopherol. Edible vegetable oil can be added to adjust the required amount of total tocopherols.

Compositional Specifications of d- α -Tocopherol Concentrate

Content d- α -Tocopherol Concentrate should contain not less than 40.0% of total tocopherol, of which not less than 95.0% consists of d- α -tocopherol.

Description d- α -Tocopherol Concentrate is pale yellow~reddish brown, clear viscous oil with slightly characteristic odor.

Identification (1) 50 mg of d- α -Tocopherol Concentrate is dissolved in 10 mL of absolute alcohol, where 2 mL of nitric acid is added. When this solution is heated for 15 minutes at 75°C, bright red or orange colour developed.

(2) The retention time of the major peak in the chromatogram of the sample solution is the same as that of the standard solution, both relative to the internal standard, as obtained in the Assay.

Purity (1) Acidity : 1 g of d- α -Tocopherol Concentrate is dissolved in 25 mL of a mixture of equal volumes of alcohol and ether that has been neutralized to phenolphthalein TS with 0.1 N sodium hydroxide. 0.5 mL of phenolphthalein TS is added to this solution, which is then titrated with 0.1 N sodium hydroxide solution until the solution remains pale red color after shaking for 30 seconds. The consumed amount of the titrant should not be more than 1 mL.

(2) Lead : When 5.0 g of d- α -Tocopherol Concentrate is tested by Atomic Absorption Spectrophotometry or Inductively Coupled Plasma Emission Spectroscopy, its content should not be more than 2.0 ppm.

(3) Specific Rotation : d- α -Tocopherol Concentrate is weighed, equivalent to about 100 mg of total tocopherol, to a separator, and dissolved it in 50 mL of ether. It is added 20 mL of a 10% solution of potassium ferricyanide in sodium hydroxide solution (1→125) to the separator, and shake for 3 minutes. Ether solution is washed with 50m of water and dehydrated with anhydrous sodium sulfate. It is evaporated the dried ether solution on a water bath under reduced pressure until about 7 ~ 8 mL remain, and then removed the last traces of ether in a blowing nitrogen at a room temperature. The residue is immediately dissolved in 5 mL of isooctane. When specific rotation is calculated, it should be high α -type $[\alpha]_D^{25} = +24^\circ$ (or higher).

Assay Should follow the procedure in Assay for d-tocopherol (mixed).

d-Tocopherol Concentrate, Mixed

Synonyms: RRR-Tocopherols concentrate, mixed

INS No.: 307b

Definition Mixed d-Tocopherol Concentrate is a concentrate of d-Tocopherol obtained from edible vegetable oil. Main ingredients are d- α -Tocopherol, d- β -Tocopherol, d- γ -Tocopherol, and d- δ -Tocopherol. Edible vegetable oil can be added to adjust the content.

Compositional Specifications of d-Tocopherol Concentrate, Mixed

Content Mixed d-Tocopherol Concentrate contains not less than 34.0% of total tocopherol.

Description Mixed d-Tocopherol Concentrate is yellow~reddish brown viscous liquid having a characteristic odor.

Identification (1) 50 mg of Mixed d-Tocopherol Concentrate is dissolved in 10 mL of anhydrous alcohol, where 2 mL of nitric acid is added. When this solution is heated at 75°C for 15 minutes, the solution developed bright red or orange.

(2) The retention time of major peak of chromatogram (obtained in Assay) for high α -type match with those of standard preparation as compared with the retention time of peak of internal standard. The retention time of the third major peak of chromatogram (obtained in Assay) for low α -type matches with that of standard preparation as compared with internal standard.

Purity (1) Acidity : 1 g of Mixed d-Tocopherol Concentrate is dissolved in 25 mL of mixture of equal volumes of alcohol and ether that has been neutralized to phenolphthalein TS with 0.1 N sodium hydroxide, 0.5 mL of phenolphthalein TS is added to this solution, which is then titrated with 0.1 N sodium hydroxide solution until the solution remains faintly pink after shaking for 30 seconds. Not more than 1 mL of 0.1 N sodium hydroxide is required.

(2) Lead : When 5.0 g of Mixed d-Tocopherol Concentrate is tested by Atomic Absorption Spectrophotometry or Inductively Coupled Plasma Emission Spectroscopy, its content should not be more than 2.0 ppm.

(3) Arsenic : It should be no more than 4.0 ppm tested by Arsenic Limit Test.

(4) Mercury : When 0.1 g of Mixed d-Tocopherol Concentrate is tested by Mercury Test Method, its content should not be more than 1.0ppm.

(5) Specific Rotation : Mixed d-Tocopherol Concentrate is weighed, equivalent to about 100 mg of total tocopherols, to a separator and dissolved in 50 mL of ether. It is added 20 mL of a 10% solution of potassium ferricyanide in sodium hydroxide solution (1→125), and shake for 3 minutes. Ether solution is washed with 50 mL of water and dehydrated with anhydrous sodium sulfate. It is evaporated the dried ether solution on a water bath under reduced pressure until about 7 ~ 8 mL remain, and then removed the last traces of ether in a blowing nitrogen at a room temperature. The residue is immediately dissolved in 5 mL of isooctane. When specific rotation is calculated, it should be high α -

type $[\alpha]_D^{25} = +24^\circ$ (or higher), low α -type $[\alpha]_D^{25} = +20^\circ$ (or higher).

Assay

Solutions

- Internal Standard Solution : About 600 mg of hexadecyl hexadecanoate is precisely weighed and dissolved in 2 parts of pyridine and 1 part of anhydrous propionic acid in a 200 mL volumetric flask, and diluted to volume with the solution.
- Preparation of Standard Solution : 12, 25, 37, and 50 mg portions of α -tocopherol standard is precisely weighed into each of 50 mL Erlenmeyer flask with a ground joint neck, where 25 mL each of internal standard solution is added. It is refluxed for 10 minutes under water-cooled condensers.
- Preparation of Test Solution : About 60 mg of Mixed d-Tocopherol Concentrate is precisely weighed into another Erlenmeyer flask, where 10 mL each of internal standard solution is added. It is refluxed for 10 minutes under water-cooled condensers. Gas chromatography is carried out under the following conditions.

Operation Conditions

- Column : Glass tube 4 mm inner diameter \times 2 m length
- Column Filler : 80 to 100 mesh Chromosorb W-DMCS coated with 2% to 5% methylpolysiloxane gum
- Detector : (Hydrogen) Flame Ionization Detector (FID)
- Temperature at injection port : 290°C
- Column Temperature : a constant temperature in a range of 240~260°C
- Detector Temperature : 300°C
- Carrier gas and its flow rate : Nitrogen, Flow rate is adjusted so that hexadecyl hexadecanoate is detected in 18~20 minutes.

System Suitability

Chromatograph a suitable number of injections of the Assay Preparation, as directed under Calibration, to assure that the resolution factor, R, between the major peaks occurring at retention times of approximately 0.5(δ -tocopheryl propionate) and 0.63(β - γ -tocopheryl propionate), relative of hexadecyl hexadecanoate at 1.0, is not less than 2.5.

Calibration Curve

Chromatograph successive 2 to 5 μ L portions of each Standard Preparation until the relative response factor, F, for each is constant (i.e. within a range of approximately 2%) for three consecutive injection. Measure the areas under the first (α -tocopheryl propionate) and the second (hexadecyl hexadecanoate)

major peaks (excluding the solvent peak), and record the values as A_s & A_1 , respectively.

A factor "F" for each concentration of each Standard Solution is obtained from the following equation.

$$F = \frac{A_s}{A_1} \times \frac{C_1}{C_s}$$

C_1 : Exact concentration of internal standard solution (mg/mL)

C_s : Exact concentration of tocopherol standard solution (mg/mL)

Relative reaction coefficient curve is prepared by plotting peak area of α -tocopheryl propionate vs. relative reaction coefficient.

Test Procedure : 2~5 μ l of Test Solution is injected into chromatograph and measured the areas under the four major peaks occurring at relative retention times of 0.50, 0.63, 0.76, and 1.00. The content (mg) of each tocopherol type for δ -tocopheryl propionate, β - + γ -tocopheryl propionate, α -tocopheryl propionate and hexadecyl hexadecanoate in sample is calculated by the following equation.

$$\delta\text{-tocopherol} = \frac{10C_1}{F} \times \frac{a_\delta}{a_1}$$

$$\beta\text{-} + \gamma\text{-tocopherol} = \frac{10C_1}{F} \times \frac{a_{\delta+\gamma}}{a_1}$$

$$\alpha\text{-tocopherol} = \frac{10C_1}{F} \times \frac{a_\alpha}{a_1}$$

F is obtained from the relative response factor curve for each the corresponding areas under the δ -, β - + γ -, and α -tocopheryl propionate peak produced by the Sample Preparation. The relative response factor for δ -tocopheryl propionate and for β - + γ -tocopheryl propionate has been determined empirically to be the same as for α -tocopheryl propionate.

d- α -Tocopheryl Acetate



Chemical Formula: $C_{31}H_{52}O_3$

Molecular Weight: 472.75

CAS No.: 58-95-7

Compositional Specifications of *d*- α -Tocopheryl Acetate

Content *d*- α -Tocopheryl Acetate ($C_{31}H_{52}O_3$) should contain within a range of 96.0 ~ 102.0% of *d*- α -Tocopheryl Acetate.

Description *d*- α -Tocopheryl Acetate occurs as a colorless to yellow, viscous liquid. It is odorless or has a characteristic odor.

Identification (1) Add, with swirling, 2 mL of nitric acid to 10 mL of test solution from Purity (3) specific rotation, and heat at about 75°C for 15 min. A bright-red to orange color develops.

(2) The retention time of the major peak in the chromatogram of the test solution is the same as that of the standard solution, both relative to the internal standard solution, as obtained in the Assay.

Purity (1) Acidity : Dissolve 1g of *d*- α -Tocopheryl Acetate in 25 mL of a 1:1 alcohol:ether mixture that has been neutralized to phenolphthalein with 0.1N sodium hydroxide. Add 0.5 mL of phenolphthalein, and titrate with 0.1N sodium hydroxide until the solution remains faintly pink after shaking for 30 s. The consumed amount of the titrant should not be more than 1.0 mL.

(2) Lead : Transfer 10 g of *d*- α -Tocopheryl Acetate, precisely weighed, into a crucible or a platinum dish. Add 5 mL of 25% sulfuric acid cautiously and mix well, which is then evaporated to dryness on a steam bath. Place the dish on a heating plate, preash slowly until most of sulfuric acid disappears, and then ash at 450~550°C. Repeat the above mentioned procedure when ashing is insufficient. Prepare sample blank by ashing 5 mL of 25% sulfuric acid under the same method. After ashing, add 5 mL of 1N hydrochloric acid and dry it on a steam bath. Add 1 mL of 3N hydrochloric acid and approximately 5 mL of distilled water and dissolve any residue on a steam bath. Transfer each solution quantitatively to a 10 mL volumetric flask, dilute to volume with distilled water, and mix. Dilute it if necessary. This solution is used for test solution. When the test solution is tested by Atomic Absorption Spectrophotometry or Inductively Coupled Plasma Emission Spectroscopy, its content should not be more than 2.0 ppm.

(3) Specific rotation

Preparation of Test Solution : Transfer an accurately weighed amount of *d*- α -Tocopheryl Acetate, equivalent to about 200 mg of *d*- α -Tocopherol, into a 150 mL round-bottom, glass-stoppered flask,

and dissolve it in 25 mL of absolute alcohol. Add 20 mL of a 1:7 mixture of 2N sulfuric acid in alcohol, and reflux for 3 h, protected from sunlight. Cool, transfer into a 200 mL brown volumetric flask, dilute to volume with a 1:72 mixture of 2 N sulfuric acid in ethyl alcohol, and mix. This solution is used for test solution.

Procedure : Transfer an accurately weighed amount of the test solution, equivalent to about 100 mg of d- α -Tocopherol, into a separatory funnel, and add 200 mL of distilled water. Extract first with 75 mL of ether, then with two 25 mL portions of ether, and combine the ether extracts in another separatory funnel. Add 20 mL of a 10% solution of potassium ferricyanide in sodium hydroxide solution (1→125) to the ether solution, and shake for 3 min. Wash the ether solution four times with 50 mL portions of water, discard the water phase, and dry over anhydrous sodium sulfate. Evaporate the dried ether solution on a water bath or in an atmosphere of nitrogen until 7 or 8 mL remain, and then complete the evaporation, removing the last traces of ether without the application of heat, Immediately dissolve the residue in 5 mL of isooctane, and determine the optical rotation. When specific rotation is measured, $[\alpha]$ should not be less than $[\alpha]=+24^\circ$

Assay

Test Solution and Solution Preparation

Internal Standard Solution : Prepare a solution containing about 3 mg of hexadecyl hexadecanoate in each mL of n-hexane.

Preparation of Standard Solution : Dissolve about 30 mg of d- α -Tocopheryl Acetate standard, precisely weighed, in 10 mL of internal standard solution.

Preparation of Test Solution : Dissolve about 30 mg of d- α -Tocopheryl Acetate, precisely weighed, in 10 mL of internal standard solution.

Operation Conditions

Column : HP-1(30m \times 0.32 μ m) or equivalent to this.

Detector : Flame Ionization Detector (FID)

Injector Temperature : 290°C

Column Temperature : 240~260°C

Detector Temperature : 300°C

Carrier gas : Nitrogen

System Suitability : Chromatograph a suitable number of injections of 1 mg each of d- α -Tocopherol standard and d- α -Tocopheryl Acetate standard per mL of n-hexane, as directed under calibration curve section, to ensure that the resolution [R] is not less than 1.0.

Calibration Curve : Chromatograph successive 2 ~ 5 μ l portions of standard solution until the relative response factor is constant (within a range of 2%) for three consecutive injections. Measure the areas under the major peaks occurring at relative retention times of approximately 0.60 for d- α -Tocopheryl Acetate (A_s) and 1.0 for hexadecyl hexadecanoate (A_i , solvent peak excluded), and record the values as A_s and A_i , respectively.

A relative response factor "F" for each concentration of each standard solution is obtained from the following equation.

$$F = \frac{A_s}{A_1} \times \frac{C_1}{C_s}$$

C_1 : Exact concentration of internal standard solution (mg/mL)

C_s : Exact concentration of d- α -Tocopheryl Acetate standard solution (mg/mL)

Procedure : Chromatograph 2~5 μ l of test solution as described under calibration curve section. Measure the areas under the major peaks occurring at relative retention times of approximately 0.60 for d- α -Tocopheryl Acetate and 1.0 for hexadecyl hexadecanoate, and record the values as a_u and a_i , respectively. Calculate the content of d- α -Tocopheryl Acetate (mg) in the sample by the following equation.

$$\text{d-}\alpha\text{-Tocopheryl Acetate(\%)} = \frac{10C_1}{F} \times \frac{a_u}{a_i} \times \frac{100}{\text{Weight of the sample (mg)}}$$

d- α -Tocopheryl Acid Succinate

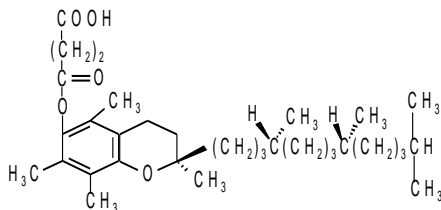

Chemical Formula $C_{33}H_{54}O_5$

Molecular Weight 530.79

Compositional Specifications of *d*- α -Tocopheryl Acid Succinate

Content *d*- α -Tocopheryl Acid Succinate ($C_{33}H_{54}O_5$) should contain within a range of 96.0 ~ 102.0% of *d*- α -Tocopheryl Acid Succinate.

Description *d*- α -Tocopheryl Acid Succinate occurs as a white to light gray

Identification (1) Add, with swirling, 2 mL of nitric acid to 10 mL of test solution from Purity (3) specific rotation, and heat at about 75°C for 15 min. A bright-red to orange color develops.

(2) The retention time of the major peak in the chromatogram of the Test Solution is the same as that of the standard solution, both relative to the internal standard solution, as obtained in the Assay.

Purity (1) Acidity : Dissolve 1g of *d*- α -Tocopheryl Acid Succinate in 25 mL of a 1:1 alcohol:ether mixture that has been neutralized to phenolphthalein with 0.1N sodium hydroxide. Add 0.5 mL of phenolphthalein, and titrate with 0.1N sodium hydroxide until the solution remains faintly pink after shaking for 30 s. The consumed amount of the titrant should be within a range of 18.0~19.3 mL.

(2) Lead : Transfer 10 g of *d*- α -Tocopheryl Acid Succinate, precisely weighed, into a crucible or a platinum dish. Add 5 mL of 25% sulfuric acid cautiously and mix well, which is then evaporated to dryness on a steam bath. Place the dish on a heating plate, preash slowly until most of sulfuric acid disappears, and then ash at 450~550°C. Repeat the above mentioned procedure when ashing is insufficient. Prepare sample blank by ashing 5 mL of 25% sulfuric acid under the same method. After ashing, add 5 mL of 1N hydrochloric acid and dry it on a steam bath. Add 1 mL of 3N hydrochloric acid and approximately 5 mL of water and dissolve any residue on a steam bath. Transfer each solution quantitatively to a 10 mL volumetric flask, dilute to volume with water, and mix. Dilute it if necessary. This solution is used for test solution. When the test solution is tested by Atomic Absorption Spectrophotometry or Inductively Coupled Plasma Emission Spectroscopy, its content should not be more than 2.0 ppm.

(3) Specific rotation

Preparation of Test Solution : Transfer an accurately weighed amount of *d*- α -Tocopheryl Acid Succinate, equivalent to about 200 mg of *d*- α -Tocopherol, into a 250 mL round-bottom, glass-stoppered flask, dissolve it in 50 mL of absolute alcohol, and reflux for 1 min. While the solution is boiling, add slowly about 1 g of potassium hydroxide pellets through the condenser to avoid overheating. Continue

refluxing for 20 min, and then, without cooling, add 2 mL of hydrochloric acid, dropwise, through the condenser. (This is essential to prevent oxidative action by air while the sample is in an alkaline medium.) Cool, and transfer the contents of the flask into a 500 mL separatory funnel, rinsing the flask with 100 mL each of water and of ether and adding the rinsings to the separatory funnel. Shake vigorously, allow the layers to separate, and collect each of the two layers in separate separatory funnels. Extract the aqueous layer with two 50 mL portions of ether, and add these extracts to the main ether extract. Wash the combined ether extracts with four 100 mL portions of water, and then evaporate the solutions on a water bath or in an atmosphere of nitrogen until about 7~8 mL remain. Complete the evaporation, removing the last traces of ether at room temperature. Immediately dissolve the residue in a 1:72 mixture of 2 N sulfuric acid in ethyl alcohol to bring the total volume of 200 mL. This solution is used for the test solution.

Procedure : Transfer an accurately weighed amount of the test solution, equivalent to about 100 mg of d- α -Tocopherol, into a separatory funnel, and add 200 mL of water. Extract first with 75 mL of ether, then with two 25 mL portions of ether, and combine the ether extracts in another separatory funnel. Add 20 mL of a 10% solution of potassium ferricyanide in sodium hydroxide solution (1→125) to the ether solution, and shake for 3 min. Wash the ether solution with four 50 mL portions of water, discard the washings, and dry over anhydrous sodium sulfate. Evaporate the dried ether solution on a water bath or in an atmosphere of nitrogen until 7~8 mL remain, and then complete the evaporation, removing the last traces of ether at room temperature, Immediately dissolve the residue in 5 mL of isooctane, and determine the optical rotation. When specific rotation is measured, $[\alpha]$ should not be less than $+24^\circ$

Assay Test Solution and Solution Preparation

Internal Standard Solution : Prepare a solution containing about 3 mg of hexadecyl hexadecanoate in each mL of n-hexane.

Preparation of Standard Solution : Transfer about 30 mg of d- α -Tocopheryl Acid Succinate standard, precisely weighed, into an approximately 15 mL screw cap vial. Pipet 2 mL of absolute methyl alcohol, 1 mL of 2,2-dimethoxypropane, and 0.1 mL of concentrated hydrochloric acid into the vial, cap, mix well, and allow to stand in the dark for 1 h. Evaporate to dryness on a steam bath with the aid of a stream of nitrogen. Pipet 10 mL of internal standard solution into the vial, cap, and shake vigorously.

Preparation of Test Solution: Prepare as directed for the preparation of standard solution, using an precisely weighed amount of sample equivalent to about 30 mg of d- α -Tocopheryl Acid Succinate.

Operation Conditions

Column : HP-1(30m \times 0.32 μ m) or equivalent to this.

Detector : Flame Ionization Detector (FID)

Injector Temperature : 290°C

Column Temperature : 260~280°C isothermally

Detector Temperature : 300°C

Carrier gas : Nitrogen

System suitability : Chromatograph a suitable number of injections of 1 mg each of d- α -Tocopherol standard and d- α -Tocopheryl Acid Succinate standard per mL of n-hexane, as directed under calibration curve section, to ensure that the resolution [R] is not less than 1.0.

Calibration Curve : Chromatograph successive 2 ~ 5 μ l portions of standard solution until the relative response factor is constant (within a range of 2%) for three consecutive injections. Measure the areas under the major peaks occurring at relative retention times of approximately 1.99 for methyl α -Tocopheryl Succinate (A_s) and 1.0 for hexadecyl hexadecanoate (A_i) and record the values as A_s and A_i , respectively.

A relative response factor "F" for each concentration of each standard solution is obtained from the following equation.

$$F = \frac{A_s}{A_i} \times \frac{C_i}{C_s}$$

C_i : Exact concentration of internal standard solution (mg/mL)

C_s : Exact concentration of d- α -Tocopheryl Acid Succinate standard solution (mg/mL)

Procedure : Chromatograph 2~5 μ l of the test solution as described under calibration curve section. Measure the areas under the major peaks occurring at relative retention times of approximately 1.99 for methyl α -Tocopheryl Succinate and 1.0 for hexadecyl hexadecanoate, and record the values as a_u and a_i , respectively. Calculate the content of d- α -Tocopheryl Acid Succinate (%) in the sample by the following equation.

$$d\text{-}\alpha\text{-Tocopheryl Acid Succinate(\%)} = \frac{10C_i}{F} \times \frac{a_u}{a_i} \times \frac{100}{\text{weight of the sample(mg)}}$$

Tomato Color

Synonyms: Natural yellow 27

INS No.: 160d(ii)

Definition

Tomato Color is a pigment obtained from tomatoes (*Lycopersicon esculentum* MILLER) of solanaceae by the following processes. Tomatoes are extracted with oil/fat. Or, dehydrated tomatoes in room temperature or heating condition are extracted with hexane or acetone and solvents are removed. Or, tomato juice is partitioned. Its major pigment component is lycopene of carotinoids. Diluent, stabilizer, or solvent can be added for the purpose of color value adjustment and quality preservation.

Compositional Specifications of Tomato Color

Content Color value ($E_{1\text{cm}}^{10\%}$) of Tomato Color should be more than the indicated value.

Description Tomato Color is dark red powder or oily liquid with a slight characteristic scent.

Identification Test Solution obtained in Color Value section has a maximum absorption band near 472 nm.

Purity (1) Arsenic : It should be no more than 4.0 ppm tested by Arsenic Limit Test.

(2) Lead : When 5.0 g of Tomato Color is tested by Atomic Absorption Spectrophotometry or Inductively Coupled Plasma Emission Spectroscopy, its content should not be more than 10.0 ppm.

(3) Cadmium : When 5.0 g of Tomato Color is tested by Atomic Absorption Spectrophotometry or Inductively Coupled Plasma Emission Spectroscopy, its content should not be more than 1.0 ppm.

(4) Mercury : When Tomato Color is tested by Mercury Limit Test, its content should not be more than 1.0ppm.

(5) Residual Solvents : When Tomato Color is tested by Purity (5) for Paprika Extract Pigments, the content of residual solvents should be,

Acetone Not more than 30ppm

Hexane Not more than 25ppm

Residue on Ignition When Tomato Color is tested by the procedure in Residues on Ignition, its content should not be more than 0.1%.

Assay(color value) Appropriate amount of Tomato Color is precisely weighted so that the absorption is within 0.3 ~ 0.7 and dissolved in 50 mL of dichloromethane. The total volume is brought up to 100 mL with petroleum ether. 1 mL of this solution is diluted to 100 mL with petroleum ether (Test Solution). If necessary, the solution is centrifuged and the supernatant is used. Using petroleum ether as a reference solution, absorption A is measured at the maximum absorption near 472 nm with 1cm path length. Color value is obtained using the following equation.

$$= \frac{A \times 1,000}{\text{_____}}$$

Color Value($E_{1cm}^{10\%}$)

Weight of the sample(g)

Tragacanth Gum

INS No.: 413

Synonyms: Tragant

CAS No.: 9000-65-1

Definition Tragacanth Gum is a polysaccharide obtained by drying the exuded secretion from stems of *Astragalus gummifer* LABILL. of leguminosae or allied species.

Compositional Specifications of Tragacanth Gum

Description Tragacanth Gum is white or whitish powder or white ~ pale yellowish white, semi-transparent flexible keratinous platelet or thin fragments.

Identification (1) When 50 mL of water is added to 1 g of Tragacanth Gum, it gradually forms almost uniformly dispersion.

(2) When iodine solution is added to the powder of Tragacanth Gum and examined under a microscope, a few number of blue starch grains are observed.

Purity (1) Arsenic : It should be no more than 4.0 ppm tested by Arsenic Limit Test.

(2) Lead : When 5.0 g of Tragacanth Gum is tested by Atomic Absorption Spectrophotometry or Inductively Coupled Plasma Emission Spectroscopy, its content should not be more than 2.0 ppm.

(3) Cadmium : When 5.0 g of Tragacanth Gum is tested by Atomic Absorption Spectrophotometry or Inductively Coupled Plasma Emission Spectroscopy, its content should not be more than 1.0 ppm.

(4) Mercury : When 0.1 g of Tragacanth Gum is tested by Mercury Test Method, its content should not be more than 1.0ppm.

(5) E. Coli : When Tragacanth Gum is tested by Microbe Test Methods for E. Coli in General Test Method 「Standards and Specifications for Foods」, it should be negative (-).

(6) Salmonella : When Tragacanth Gum is tested by Microbe Test Methods for Salmonella in General Test Method 「Standards and Specifications for Foods」, it should be negative (-).

(7) Karaya Gum : 20 mL of water is added to 1 g of Tragacanth Gum, which is boiled until it forms a homogeneous viscous liquid. 5 mL of hydrochloric acid is add to the this solution, which is then boiled for 5 minutes. its color should not develop light pink ~ red.

(8) Viscosity : 4.0 g of fine powder is weighed into a stirring container. It is uniformly wetted with 10 mL of alcohol, added 390 mL of water, then stirred with for 7 minutes (care must be taken to prevent lump formation). The resulting suspension is transferred into a 500 mL bottle. It is then capped and allowed to stand for 24 hours in a 25°C water bath (Test Solution). Test Solution is tested by 2. Rotational Type Viscosity Measurement in Viscosity Measurement. It should not be less than 250 cps.

(9) Acid Insoluble Ash : When Tragacanth Gum is tested as directed under Acid Insoluble Ash in Ash Test Method, the amount should not be more than 0.5%.

Ash When Tragacanth Gum is tested as directed under total ash in Ash Test, the amount of ash should not be more than 3.0%.

Tansglucosidase

1,4- α -D-Glucan 6- α -D-glucosyl transferase

Definition Tansglucosidase is an enzyme obtained from a culture of *Aspergillus niger* and its variety, the culture of *Bacillus* sp and culture of *Trichoderma reesei* inserted gene of transglucoamylase from *Aspergillus niger*. Dilutant or stabilizer can be added for the purpose of activity adjustment and quality preservation.

Compositional Specifications of Tansglucosidase

Description Tansglucosidase is white ~ dark brown powder, particle, paste or colorless ~ dark brown liquid.

Identification When Tansglucosidase is proceeded as directed under Activity Test, it should have the activity as Tansglucosidase.

Purity (1) Arsenic : It should be no more than 4.0 ppm tested by Arsenic Limit Test.

(2) Lead : When 5.0 g of Tansglucosidase is tested by Atomic Absorption Spectrophotometry or Inductively Coupled Plasma Emission Spectroscopy, its content should not be more than 5.0 ppm.

(3) Coliform Group : When Tansglucosidase proceed as directed under Microbiological Methods for Coliform Group in General Testing Methods in 「Standards and Specifications for Foods」, it should not contain more than 30 per 1 g of this product.

(4) Salmonella : When Tansglucosidase proceed as directed under Microbiological Methods for Salmonella in General Testing Methods in 「Standards and Specifications for Foods」, it should be negative (-).

(5) E. Coli : When Tansglucosidase is tested by Microbe Test Methods for E. Coli in General Test Method 「Standards and Specifications for Foods」, it should be negative (-).

Activity Test (activity)

◦ Analysis Principle : Activity test is based on substrate hydrolysis of methyl-D-glucoside at 40°C for 60 minutes and pH 5.0.

◦ Preparation of Test Solution : Test Solution (in water) is prepared so that the difference in absorption ($A_S - A_B$) is 0.15~0.32 under following test method.

◦ Test Procedure : 1 mL of substrate solution and 1 mL of acetic acid sodium acetate buffer solution (pH 5.0) are mixed in a test tube, which is isothermalized for 5 minutes in a $40 \pm 0.5^\circ\text{C}$ water bath. Exactly 0.5 mL of Test Solution is added to the tube, which is mixed by shaking and set aside for 60 minutes in a $40 \pm 5^\circ\text{C}$ water bath. It is then heated for 5 minutes in a boiling water bath and cooled in running water. 0.1 mL of this solution is added to a test tube, where 3 mL of colorizing solution is added. It is set aside for 20 minutes at $40 \pm 0.5^\circ\text{C}$. Absorption (A_S) of the resulting solution is measured at 505 nm with 1cm path length using water as a reference. Separately for enzyme blank test, 1 mL of acetic acid sodium acetate buffer solution (pH 5.0) and 0.5 mL of Test Solution are added to a test tube, which is set aside for 60 minutes at $40 \pm 0.5^\circ\text{C}$. Heat the test tube for 5 minutes in a boiling water bath, and

cool it in running water. After adding 1 mL of substrate solution, absorption (A_B) is measured using the same procedure as Test Solution.

Standard Curve

Glucose is dried for 6 hours at 105°C. 1 g of dried glucose is precisely weighted and dissolved in water (total volume = 100 mL, 100 mg/mL). A set of glucose standard solutions are prepared so that each solution contains 100 µg, 200 µg, 300 µg, 400 µg, and 500 µg per 1 mL. 0.1 mL of glucose standard solution. Each glucose standard solution is placed in a test tube, where 3 mL of colorizing solution is added. It is then set aside for 20 minutes in a $40 \pm 0.5^\circ\text{C}$ water bath. Separately, a reference solution is prepared using water instead of standard solution. Absorption for each standard solution is measured. A standard curve of absorption versus concentration of glucose (µg).

Enzyme activity is obtained using the following equation.

$$\text{Transglucosidase unit/g} = (A_S - A_B) \times G \times \frac{2.5}{0.5} \times \frac{n}{0.1 \times W}$$

G : Amount of glucose (µg) where the difference in absorption is 1 (obtained from the standard curve).

n : Dilution factor of test solution

W : Weight of sample(g)

Definition of Activity : 1 Transglucosidase unit corresponds to an amount of enzyme that produces 1 µg of glucose in 60 minutes under the test conditions above.

Solutions

- Substrate Solution : 2 g of α-Methyl-D-glucoside is weighted and dissolved in water (total volume = 100 mL).
- Acetic Acid · Sodium Acetate Buffer Solution (pH 5.0) : 0.02 M acetic acid are added to 0.02 M sodium acetate solution so that pH becomes 5.0.
- Colorizing Solution : After dissolve Glucose oxidase 550 unit, peroxidase 125 unit in 40 mL of tris-phosphate buffer solution(pH 7.2), add 1 mL of 0.4% of 4-aminoantipyrine solution and 1.4 mL of phenol solution(5%) and tris-phosphate buffer solution(pH 7.2) to make to 50 mL.

Storage Standards of Transglucosidase

Transglucosidase is strongly hygroscopic. Store in a cold dark place and well-closed containers.

Transglutaminase

Definition Transglutaminase is an enzyme obtained by the following procedure. Cultures of *Streptovercillium mobaraense* are extracted with water. The extracts are treated with cold ethyl alcohol to obtain enzyme. Diluent or stabilizer can be added for the purpose of activity adjustment and quality preservation.

Compositional Specifications of Transglutaminase

Description Transglutaminase is white ~ deep brown powder, granule, paste, or colorless ~ deep brown liquid.

Identification When Transglutaminase is proceeded as directed under Activity Test, it should have the activity as Transglutaminase.

Purity (1) Arsenic : It should be no more than 4.0 ppm tested by Arsenic Limit Test.

(2) Lead : When 5.0 g of Transglutaminase is tested by Atomic Absorption Spectrophotometry or Inductively Coupled Plasma Emission Spectroscopy, its content should not be more than 5.0 ppm.

(3) Coliform Group : Transglutaminase is tested by Microbiological Methods for Coliform Group in General Testing Methods in 「Standards and Specifications for Foods」. It should contain 30 or less per 1 g of Transglutaminase.

(4) Salmonella : Transglutaminase is tested by Microbiological Methods for Salmonella in General Testing Methods in 「Standards and Specifications for Foods」. It should be negative (-).

(5) E. Coli : When Transglutaminase is tested by Microbe Test Methods for E. Coli in General Test Method 「Standards and Specifications for Foods」, it should be negative (-).

Activity Test (activity) Analysis Principle : Activity test is based on generation of glutamate- γ -hydroxamate from the reaction between glutamic acid group and hydroxylamine.

◦Preparation of Test Solution : An appropriate amount of sample is dissolve in approximately 45 mL of 0.2 M tris-hydrochloric acid buffer solution (pH 6.0) by stirring for 30 minutes at room temperature. The solution is diluted exactly to 50 mL with 0.2 M tris-hydrochloric acid buffer solution (pH 6.0). The concentration should be such that an absorption value (measured by the following Test Procedure) lies within a range of 0.3 ~ 0.7.

◦Test Procedure : Exactly 0.2 mL of Test Solution is placed in a test tube, which is pre-heated for 1 minutes in a $37 \pm 1^\circ\text{C}$ water bath. 2 mL of substrate solution (previously isothermalized for 10 minutes at $37 \pm 1^\circ\text{C}$) is added to Test Solution and mixed by shaking immediately. This solution is set aside in the same water bath for exactly 10 minutes at $37 \pm 1^\circ\text{C}$, where 2 mL of colorizing solution is added. The reaction is stopped and the reaction mixture is centrifuged for 10 minutes at 3,000 rpm to separate the precipitates. Absorption of the supernatant is measured at 525 nm using water as a reference. Separately, enzyme blank test solution is prepared as follows. 0.2 mL of Test Solution and 2 mL of colorizing solution are mixed by shaking and set aside for 10 minutes at $37 \pm 1^\circ\text{C}$. After adding 2 mL of substrate solution to the resulting solution, it is centrifuged at 3,000 rpm. Absorption is measured by the same procedure

as the enzyme test solution. Absorption of Test Solution is obtained by subtracting the absorption of enzyme blank test solution from that of enzyme test solution.

◦ Standard Curve

64.8 mg of L-glutamate-γ-monohydroxamate is precisely weighted and dissolved in 10 mL of 0.2 M tris-hydrochloric acid buffer solution (pH 6.0). Standard Solutions are prepared so that 1 mL each contains 8.0, 16.0, 20.0, 24.0, and 32.0 μmol of L-glutamate-γ-monohydroxamate. 2 mL of substrate solution is added to 0.2 mL of each Standard Solution at 37 ± 1°C and set aside for 10 minutes. After adding 2 mL of colorizing solution, precipitates are removed by the same procedure as Test Solution. Absorptions at 525 nm are measured using water as a reference. A standard curve of absorption vs. concentration of L-glutamate-γ-monohydroxamate (μmol/mL) is prepared.

Enzyme activity is calculated by the following equation.

$$U/g = (A_s - A_B) \times G \times \frac{2.5}{0.5} \times \frac{n}{0.1 \times W}$$

$$\text{units/g} = \frac{C \times D}{W \times 10}$$

C : Concentration of hydroxamate of Test Solution obtained from the standard curve (μmol/mL)

D : Dilution factor of Test Solution (mL)

W : Dmount of sample(g)

10 : Reaction time (minutes)

Definition of Activity : 1 Transglucosidase unit corresponds to an amount of enzyme that produces 1 μmol per 1 minute of hydroxamic acid from the substrate under the test conditions above.

Solutions

◦ Substrate Solution : 2.42 g of tris(hydroxymethyl)amino-methane, 0.7 g of hydroxylamine hydrochloride, 0.31 g of glutathione, 1.01 g of carbobenzyloxy glutaminylglycine are precisely weighted and dissolved in 80 mL of water. pH is adjusted to 6.0 with 6 N hydrochloric acid. The total volume is brought up to 100 mL with water.

◦ 0.2 M Tris-Hydrochloric Buffer Solution (pH 6.0) : 24.22 g of tris(hydroxymethyl)amino-methane dissolve in 800 mL of water and pH is adjusted to 6.0 with 2.8 N hydrochloric acid. The total volume is brought up to 1,000 mL with water. The solution is stored at 5°C in a refrigerator.

◦ Colorizing Solution

Solution 1 : 3 N hydrochloric acid

Solution 2 : 12 g of trichloro acetic acid (Cl_3COOH) dissolve in water (total volume = 100 mL).

Solution 3 : 5 g ferric chloride ($\text{FeCl}_3 \cdot 6\text{H}_2\text{O}$) dissolve in 0.1 N hydrochloric acid (total volume = 100 mL).

Same amounts of Solution 1, 2, and 3 are well mixed before use.

Storage Standards of Transglutaminase

Store in a cold place in a hermetic, light-resistant container.

Triacetin

Glyceryl Triacetate

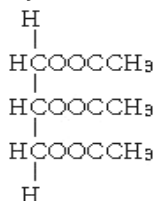

Chemical Formula: $\text{C}_9\text{H}_{14}\text{O}_6$

Molecular Weight: 218.21

INS No.: 1518

Synonyms: Glyceryl triacetate

CAS No.: 102-76-1

Compositional Specifications of Triacetin

Content Triacetin should contain not less than 98.5% of triacetin ($\text{C}_9\text{H}_{14}\text{O}_6$).

Description Triacetin is colorless liquid with slight fluidity. It has a slight fatty scent and bitter taste.

Identification (1) A few drops of Triacetin is taken into a test tube and approximately 0.5 g of potassium hydrogen sulfate is added. Upon heating, irritating vapor of acrolein is generated.

(2) A solution obtained in the Assay responds to test of acetates in Identification.

Purity (1) Specific Gravity : Specific gravity should be within a range of 1.154~1.158.

(2) Refractive Index : Refractive Index n_D^{20} of Triacetin should be within a range of 1.429~1.431.

(3) Acid Value : Approximately 25 g of Triacetin is precisely weighed. After adding 50 mL of toluene and 2 drops of thymol blue, the solution is titrated with 0.02 N sodium methoxide-toluene solution until the pale red color persists for 30 seconds. The consumed amount should not be more than 1.0 mL.

(4) Unsaturated matter : To 10 mL of Triacetin, bromine solution in carbon tetrachloride (1→100) is drop-wise added until the solution turns yellow. When this solution is then set-aside for 18 hours in a dark place, any precipitates should not form.

(5) Lead : When 5.0 g of Triacetin is tested by Atomic Absorption Spectrophotometry or Inductively Coupled Plasma Emission Spectroscopy, its content should not be more than 2.0 ppm.

(6) Arsenic : It should be no more than 4.0 ppm tested by Arsenic Limit Test.

Water Content Water content of Triacetin is determined by water determination (Karl-Fisher Method) and should not be more than 0.2%.

Assay Approximately 1 g of Triacetin is precisely weighed into a pressurizable bottle. 25 mL of 1 N potassium hydroxide solution and 15 mL of isopropyl alcohol are added and a cap is placed. Then the bottle is immersed in a water bath so that the solution level is below the water level, which is then heated for 1 hour at $98 \pm 2^\circ\text{C}$. After cooling, the excess alkali is titrated with 0.5 N sulfuric acid (indicator : 6 ~ 8 drops of phenolphthalein solution). Separately, a blank test is carried out

1 mL of 0.5 N sulfuric acid = 36.37 mg $C_9H_{14}O_6$

Trisodium Citrate

Sodium Citrate

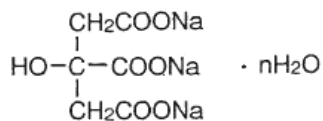

Chemical Formula: $\text{C}_6\text{H}_5\text{Na}_3\text{O}_7 \cdot n\text{H}_2\text{O}$ ($n = 0, 2, 5$)

Molecular Weight: 5hydrates 348.15

2hydrates 294.10

anhydrous 258.07

INS No.: 331(iii)

CAS No.:

68-04-2(anhydrous)

6132-04-

3(2hydrates)

Synonyms: Tribasic sodium citrate; Sodium citrate

Definition Trisodium citrate occurs as crystals (dihydrate, pentahydrate) called trisodium citrate (crystal) and as anhydrous material called trisodium citrate (anhydrous).

Compositional Specifications of Trisodium Citrate

Content Trisodium Citrate, when calculated on the dried basis, should contain within a range of 99.0 ~ 101.0% of trisodium citrate ($\text{C}_6\text{H}_5\text{Na}_3\text{O}_7 = 258.07$).

Description Trisodium Citrate occurs as colorless crystals or as white powder. It is odorless and has a fresh, salty taste.

Identification (1) Trisodium Citrate responds to the test for Citrate and Sodium Salt in Identification.

Purity (1) Clarity and Color of Solution : When Trisodium Citrate 1 g is dissolved in 20 mL of water, the solution should be colorless and almost clear.

(2) pH : pH of Trisodium Citrate solution (1→20) should be within a range of 7.6 ~ 9.0

(3) Sulfate : When 1 g of Trisodium Citrate is tested by Sulfate Limit Test in Identification, its content should not be more than the amount that corresponds to 0.5 mL of 0.01 N sulfuric acid.

(4) Arsenic : It should be no more than 1.3 ppm tested by Arsenic Limit Test.

(5) Lead : When 5.0 g of Trisodium Citrate is tested by Atomic Absorption Spectrophotometry or Inductively Coupled Plasma Emission Spectroscopy, its content should not be more than 1.0 ppm.

(6) Mercury : When Trisodium Citrate is tested by Mercury Limit Test, its content should not be more than 1.0 ppm.

Loss on Drying When Trisodium Citrate is dried at 180°C for 4 hours, the weight loss should be 30.3 % or less for pentahydrate, 13.5 % or less for dihydrate, and 1.0% or less for anhydrous form.

Assay Dissolve 0.2 g trisodium Citrate, previously dried at 180°C for 2 hours and accurately weighed, in

30 mL of glacial acetic acid (for non-aqueous titration) by heating. After cooling, the solution is titrated with 0.1 N perchloric acid (indicator : 1 mL of crystal violet-acetic acid solution). The end point is where the violet color of the solution changes to blue and then green. Separately, a blank test is carried out by the same procedure.

1 mL of 0.1 N perchloric acid = 8.602 mg of $C_6H_5O_7Na_3$

Trypsin

Definition Trypsin is an enzyme obtained from extracts of pancreas of pigs and cows. Dilutant or stabilizer can be added for the purpose of activity adjustment and quality preservation.

Compositional Specifications of Trypsin

Description Trypsin is white ~ deep brown powder, granule, paste or colorless~dark brown liquid.

Identification When Trypsin is proceeded as directed under Activity Test, it should have the activity as Trypsin.

Purity (1) Arsenic : It should be no more than 4.0 ppm tested by Arsenic Limit Test.

(2) Lead : When 5.0 g of Trypsin is tested by Atomic Absorption Spectrophotometry or Inductively Coupled Plasma Emission Spectroscopy, its content should not be more than 5.0 ppm.

(3) Coliform Group : Trypsin is tested by Microbe Test Methods for Coliform Group in General Test Methods in Food Code. It should not be more than 30 cfu per 1 g of this product.

(4) Salmonella : Trypsin is tested by Microbe Test Methods for Salmonella in General Test Methods in Food Code. It should be negative (-).

(5) E. Coli : When Trypsin is tested by Microbe Test Methods for E. Coli in General Test Method 「Standards and Specifications for Foods」 it should be negative (-).

Activity Test (activity)

◦Preparation of Test Solution : The final diluted solution in 0.001N hydrochloric acid is prepared so that it contains 3,000 trypsin units per 1 mL. A certain amount of this solution is diluted with 0.001N hydrochloric acid so that 0.2 mL of the solution contains 12, 18, and 24 Trypsin units. This solution is used as following Test Procedure.

◦Test Procedure : This test is carried out with maintaining around the cell at $25 \pm 0.1^\circ\text{C}$. Temperature of the reaction cell should be checked before and after the measurement and the difference should not be more than 0.5°C . 0.2 mL of 0.001 N hydrochloric acid and 3 mL of substrate solution are placed in a 1cm cell. It is set up in a spectrophotometer. It is adjusted so that the absorbance at 253 nm is 0.050. In another cell, accurately pipetted 0.2 mL of Test Solution containing 12 Trypsin units, where 3 mL of substrate solution is added. Using a spectrophotometer, absorbance is measured in a 30 second interval for 5 minutes. This is repeated with the Standard Solutions containing 18 and 24 Trypsin units. Absorbance curve vs. time for each concentration is plotted. Only the values in straight line region are used. An average value of 3 concentrations (only in straight line region) is taken as Trypsin activity. Trypsin units/mg for each concentration is obtained from the following equation.

$$\text{Trypsin units} = (A_1 - A_2) / (T \times W \times 0.003)$$

A1 : The last absorbance on the straight line

A₂ : The initial absorbance on the straight line

T : Time difference between the initial and the last time (min)

W : Amount of Trypsin used for absorbance measurement (mg)

Definition of Activity : 1 Trypsin unit corresponds to an activity that changes 0.003 absorbance unit per minute under the test conditions above.

Solutions

- 1/15M Phosphate Buffer Solution (pH 7.6) : 4.54 g of potassium phosphate, monobasic is dissolved in sufficient amount of water to make 500 mL. Separately, 4.73 g of anhydrous potassium phosphate, dibasic is dissolved in sufficient amount of water to make 500 mL. 13 mL of potassium phosphate, monobasic solution is mixed with 87 mL of potassium phosphate, dibasic solution
- Substrate Solution : 85.7 mg of N-benzoyl-L-arginine ethyl ester hydrochloride for Trypsin analysis is dissolved in water and the total volume is brought up to 100 mL with water (note : Using Trypsin reference standard, appropriateness of substrate and adjustment of spectrophotometer are checked). 10 mL of this solution is diluted to 100 mL with 1/15 M phosphate buffer solution (pH 7.6). Absorbance of this solution is measured at 253 nm with 1cm cell at $25 \pm 0.1^\circ\text{C}$ using water as a reference. Absorbance is adjusted to a range of 0.575~0.585 using 1/15 M phosphate buffer solution if necessary. This solution should be used within 2 hours after it is prepared.

Storage Standard of Trypsin

Trypsin is strongly hygroscopic, hence should be stored in a cold dark place with sealing tightly.

DL-Tryptophan

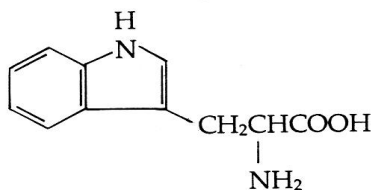

Chemical Formula: C₁₁H₁₂O₂N₂

Molecular Weight: 204.23

Synonyms: DL- α -Amino-3-indolepropionic acid

CAS No.: 54-12-6

Compositional Specifications of DL-Tryptophan

Content DL-Tryptophan, when calculated on the dried basis, should contain within a range of 98.0 ~ 102.0% of DL-tryptophan (C₁₁H₁₂O₂N₂).

Description DL-Tryptophan occurs as white to yellow crystals or crystalline, powder. It is odorless or has a slight odor and has a slightly sweet taste.

Identification (1) DL-Tryptophan solution (1→500) has no optical rotation.

(2) To 0.1 g of DL-Tryptophan, add 50 mL of water, and dissolve while heating. After cooling, to 10 mL of the solution, add 5 mL of p-dimethylaminobenzaldehyde solution and 2 mL of diluted hydrochloric acid, and heat in a water bath for 5 minutes. A red-purple to blue-purple color becomes.

(3) To 5 mL of DL-Tryptophan solution (1→1,000) add 1 mL of ninhydrin solution (1→1,000), and heat for 3 minutes. A purple color becomes.

Purity (1) Clarity and Color of Solution : Weigh 0.5 g of DL-Tryptophan, and dissolve in 10 mL of 0.5N sodium hydroxide solution. The solution should not be more than almost clear, and its color should not be darker than that of Color standard Solution C.

(2) pH : pH of DL-Tryptophan solution (1→50) should be within a range of 5.5 ~ 7.0.

(3) Arsenic : It should be no more than 4.0 ppm tested by Arsenic Limit Test.

(4) Lead : When 5.0 g of DL-Tryptophan is tested by Atomic Absorption Spectrophotometry or Inductively Coupled Plasma Emission Spectroscopy, its content should not be more than 5.0 ppm.

(5) Chloride : When 0.5 g of DL-Tryptophan is proceeded as directed under chloride, its content should not be more than the amount that corresponds to 0.3 mL of 0.01 N hydrochloric acid.

Loss on Drying When DL-Tryptophan is dried for 3 hours at 105°C, the weight loss should not be more than 0.3%.

Residue on Ignition When thermogravimetric analysis is done with approximately 1 g of DL-Tryptophan, the amount of residues should not be more than 0.1%.

Assay Approximately 0.3 g of DL-Tryptophan, previously dried and accurately weighed, is dissolved in 50

mL of glacial acetic acid by heating. After cooling, titrated with 0.1 N perchloric acid solution (indicator : 10 drops of α -naphtholbenzene solution). The end point is where the brown color of the solution becomes green.

1 mL of 0.1 N perchloric acid = 20.42 mg of $C_{11}H_{12}O_2N_2$

L-Tryptophan

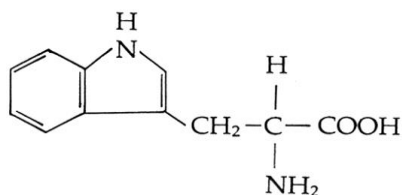

Chemical Formula: C₁₁H₁₂O₂N₂

Molecular Weight: 204.23

Synonyms: DL- α -Amino-3-indolepropionic acid

CAS No.: 54-12-6

Compositional Specifications of L-Tryptophan

Content L-Tryptophan, when calculated on the dried basis, should contain within a range of 98.0 ~ 102.0% of L-tryptophan (C₁₁H₁₂O₂N₂).

Description L-Tryptophan as white to yellowish-white crystals or crystalline powder. It is odorless or has a slight odor and has a slightly bitter taste.

Identification (1) L-Tryptophan solution is levorotatory. Add sodium hydroxide solution (1→5) to make the solution alkaline. The solution becomes dextrorotatory.

(2) Proceed as directed under Identification (2) and (3) in 「DL-Tryptophan」.

Purity (1) Clarity and Color of Solution : Weigh 0.5 g of L-Tryptophan. and dissolve in 10 mL of 0.5N sodium hydroxide solution. The solution should not be more than almost clear, and its color should not be darker than that of Color standard Solution C.

(2) pH : pH of L-Tryptophan solution (1→100) should be within a range of 5.5 ~ 7.0.

(3) Specific Rotation : L-Tryptophan is dried for 3 hours at 105°C. Approximately 0.5 g is precisely weighed and dissolved in 40 mL of water by heating. After cooling, water is added to make 50 mL solution. Optical rotation should be within a range of $[\alpha]_D^{25} = -30 \sim -33^\circ$

(4) Arsenic : It should be no more than 4.0 ppm tested by Arsenic Limit Test.

(5) Lead : When 5.0 g of L-Tryptophan is tested by Atomic Absorption Spectrophotometry or Inductively Coupled Plasma Emission Spectroscopy, its content should not be more than 5.0 ppm.

(6) Chloride : Proceed as directed under Purity (5) in 「DL-Tryptophan」.

Loss on Drying When L-Tryptophan is dried for 3 hours at 105°C, the weight loss should not be more than 0.3%.

Residue on Ignition When thermogravimetric analysis is done with approximately 1 g of L-Tryptophan, the amount of residues should not be more than 0.1%.

Assay Approximately 0.3 g of L-Tryptophan, previously dried and accurately weighed, is dissolved in 50 mL of glacial acetic acid by heating. After cooling, titrated with 0.1 N perchloric acid solution (indicator :

10 drops of α -naphtholbenzene solution). The end point is where the brown color of the solution becomes green.

1 mL of 0.1 N perchloric acid = 20.42 mg of $C_{11}H_{12}O_2N_2$

L-Tyrosine

L-β-(p-Hydroxyphenyl)alanine

Chemical Formula: C₉H₁₁NO₃

Molecular Weight: 181.19

Synonyms: L-β-(p-Hydroxyphenyl)alanine

CAS No.: 60-18-4

Compositional Specifications of L-Tyrosine

Content L- Tyrosine, when calculated on the dried basis, should contain within a range of 98.0 ~ 102.0% of L-Tyrosine (C₉H₁₁NO₃).

Description L-Tyrosine is white crystallite or crystalline powder. It is odorless, and it is tasteless or has a slightly characteristic odor.

Identification (1) To 5 mL saturated L-Tyrosine solution, add 1 mL of ninhydrin solution (1→50). When this solution is heated for 3 minutes in a water bath, it becomes bluish violet color.

(2) When 5 mL of saturated L-Tyrosine solution is mixed with 1 mL of ferrous chloride solution, which is then heated, solution becomes dark red color.

Purity (1) Clarity and Color of Solution : When 1 g of L-Tyrosine is dissolved in 20 mL of 1 N hydrochloric acid, the solution should be colorless and almost clear.

(2) pH : pH of saturated L-Tyrosine solution should be within a range of 5.0~6.5.

(3) Specific Rotation : Approximately 5 g of L-Tyrosine is precisely weighed and dissolved in 1 N hydrochloric acid, to make 100 mL. Optical rotation of L-Tyrosine is measured and converted into a dried form. It should be within a range of $[\alpha]_D^{25} = -10.5 \sim -12.5^\circ$

(4) Chloride : When 0.07 g of L-Tyrosine is proceeded as directed under chloride, its content should not more than the amount that corresponds to 0.2 mL of 0.01 N hydrochloric acid.

(5) Arsenic : It should be no more than 4.0 ppm tested by Arsenic Limit Test.

(6) Lead : When 5.0 g of L-Tyrosine is tested by Atomic Absorption Spectrophotometry or Inductively Coupled Plasma Emission Spectroscopy, its content should not be more than 5.0 ppm.

Loss on Drying When L-Tyrosine is dried for 3 hours at 105°C, the weight loss should not be more than 0.3%.

Residue on Ignition When thermogravimetric analysis is done with L-Tyrosine, the amount of residues should not be more than 0.1%.

Assay Approximately 0.3 g of L-Tyrosine is precisely weighed and dissolved in 3 mL of formic acid, where 50 mL of glacial acetic acid for non-aqueous titration is added. It is then titrated with 0.1 N perchloric acid (indicator : 1 mL Crystal violet glacial acetic acid solution). End point is where the violet color of the solution becomes through blue then to green. Separately, a blank test is carried out by the same procedure.

1 mL of 0.1 N Perchloric acid = 18.119 mg $\text{C}_9\text{H}_{11}\text{NO}_3$

r-Undecalactone

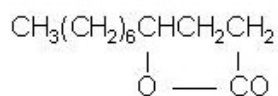

Chemical Formula: C₁₁H₂₀O₂

Molecular Weight: 184.28

Synonyms: γ -Undecyl lactone

CAS No.: 104-67-6

Compositional Specifications of r-Undecalactone

Content r-Undecalactone should contain not less than 98.0% of r-undecalactone (C₁₁H₂₀O₂).

Description r-Undecalactone is a colorless to light yellow, transparent liquid having a characteristic odor.

Identification To 1 mL of r-Undecalactone, add 6 mL of sodium hydroxide, and heat in a water bath while shaking. It almost dissolves, and the peach-like odor disappears. Acidify this solution with diluted sulfuric acid, and heat in a water bath while shaking. Oil phase separates, and a peach-like odor develops.

Purity (1) Specific Gravity : Specific gravity of r-Undecalactone should be within a range of 0.942 ~ 0.945.

(2) Refractive Index : Refractive Index n_D^{20} of r-Undecalactone should be within a range of 1.450 ~ 1.454.

(3) Clarity and Color of Solution : When 1 mL of r-Undecalactone is dissolved in 5 mL of 60% alcohol, the solution be clear.

(4) Acid Value : Acid value of r-Undecalactone is tested by Acid Value in Flavoring Substance Test. It should not be more than 5.

Assay Accurately weigh about 1 g of r-Undecalactone, and proceed as directed under Ester Value and Ester Content in flavoring Substances Tests.

1 mL of 0.5 N alcoholic potassium hydroxide = 92.14 mg of C₁₁H₂₀O₂

Urease

Definition Urease is an enzyme obtained from cultures of *Lactobacillus fermentum*. Dilutant or stabilizer can be added for the purpose of activity adjustment and quality preservation.

Compositional Specifications of Urease

Description Urease is white ~ dark brown power, granular, pasty substances or transparent ~ brown liquid.

Identification When Urease is proceeded as directed under Activity Test, it should have the activity as Urease.

Purity (1) Arsenic : It should be no more than 4.0 ppm tested by Arsenic Limit Test.

(2) Lead : When 5.0 g of Urease is tested by Atomic Absorption Spectrophotometry or Inductively Coupled Plasma Emission Spectroscopy, its content should not be more than 5.0 ppm

(3) Coliform Group : Phosphodiesterase proceed as directed under Microbe Test Methods in Coliform Group in General Test Methods in 「Standards and Specifications for Foods」. It should contain not more than 30 colonies per 1 g of this product.

(4) Salmonella : When Phosphodiesterase is tested by Microbe Test Methods for Salmonella in General Test Method 「Standards and Specifications for Foods」, it should be negative (-).

(5) E. Coli : When 25 g of Phosphodiesterase is tested by Microbe Test Methods for E. Coli in General Test Method 「Standards and Specifications for Foods」, it should be negative (-).

Activity Test (activity)

Analysis principle : Urea substrate by treating with Urease in pH 4.0 and 37°C produce ammonia. React ammonia with phenol-nitroprusside solution and alkaline sodium hypochlorite solution. Activity test is based on measuring absorbance of it.

Preparation of Test Solution : Dissolve the sample in water to make the final diluent solution conclude 0.1~0.4 unit per 1 mL.

Procedure : 0.5 mL of test solution and 2.5 mL of 0.1M acetate buffer solution(pH 4.0, 20% ethanol) are added to a test tube for enzyme test and settled at $37\pm 0.5^{\circ}\text{C}$ for 5 minutes. Precisely mix it with 1.0 mL of substrate solution warmed at $37\pm 0.5^{\circ}\text{C}$. React this solution for 30 minutes and then stop the reaction by adding 4 mL of 10% trichloroacetic acid solution (enzyme test solution). Separately, 0.5 mL of test solution and 2.5 mL of acetate buffer solution(pH 4.0, 20% ethanol) are added in the test tube for enzyme blank test, and settled for 35 minutes at $37\pm 0.5^{\circ}\text{C}$. Add 1.0 mL of substrate solution to mixed solution after adding 4 mL of 10% trichloroacetic acid solution (enzyme blank test solution). Take 2 mL of each enzyme test solution and enzyme blank test solution and add water to make 20 mL (When the sample is insoluble, it is centrifuged and 2 mL of the supernatant is used). Take 4 mL of each 10-times diluted enzyme test solution and enzyme blank test solution. After adding phenol-nitroprusside solution and alkaline sodium hypochlorite solution to these solutions, these are reacted for 30 minutes at $37\pm 0.5^{\circ}\text{C}$. Using water as a reference solution, absorbance is measured at wavelength 640 nm.

Preparation of standard curve : the solutions adding 2 mL of ammonium sulfate standard solution(0~100

$\mu\text{g/mL}$), 1 mL of 10% trichloroacetic acid solution and 0.625 mL of 0.1M acetate buffer solution(pH 4.0, 20% ethanol) to make to 20mL are measured following the same procedure as the 10 times diluted upper solutions. Using 2 mL of water as reference solution instead of 2 mL of ammonium sulfate standard solution, the absorbance is measured. A standard curve of concentration of ammonia($\mu\text{g/mL}$) is prepared.

The enzyme activity is calculated by the following formula.

$$\text{Urease} \begin{matrix} \text{(units/g or units/mL)} \end{matrix} = \frac{A \times 8.0}{17.03 \times 30 \times 0.5 \times W}$$

A : The difference of ammonia concentration of enzyme test solution and enzyme blank test solution gained from the standard curves

8.0 : Amount of final reaction solution(mL)

17.03 : Molecular weight of ammonia

30 : Reaction time(minutes)

0.5 : Amount of the test solution for reaction(mL)

W : Weight of sample in 1 mL of test solution(g or mL)

Definition of Activity : 1 Urease unit corresponds to the amount of enzyme which produces 1 μmol of ammonia per a minute under the conditions above.

Reagent

Substrate solution : Dissolve 0.60 g of urea in water and make it 100 mL.

0.1M acetate buffer solution(pH 4.0, 20% ethanol)

the 1st solution : Dissolve 6.01 g of acetic acid in water containing 20% ethanol and make it 1,000 mL.

the 2nd solution : Dissolve 13.61 g of trihydrate of sodium acetate in water containing 20% ethanol and make it 1,000 mL.

After mixing the 1st and 2nd solutions, adjust pH to 4.0

10% trichloroacetic acid solution : Add water to 100 g of trichloroacetic acid and make it 1,000 mL.

phenol-nitroprusside solution : Dissolve 5 g of phenol and 0.025 g of sodium nitroprusside in water and make it 500 mL. The solution should be stored in a cold dark place.

alkaline sodium hypochlorite solution : Dissolve 5.0 g of sodium hydroxide(commercial reagent, about 5% effective chlorine) and 7.5 mL of sodium hypochlorite solution in water and make it 500 mL. The solution is prepared before use.

Storage Standard of Urease

Urease should be stored in a hermetic container in a cold dark place.

L-Valine

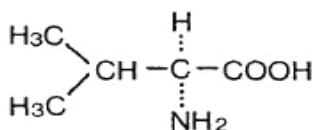

Chemical Formula: C₅H₁₁NO₂

Molecular Weight: 117.15

CAS No.: 72-18-4

Compositional Specifications of L-Valine

Content L-Valine, when calculated on the dried basis, should contain within a range of 98.0 ~ 102.0% of L-valine (C₅H₁₁NO₂).

Description L-Valine occurs as white crystals or crystalline powder. It is odorless and has a light characteristic taste.

Identification (1) Solution of L-Valine in 6 N hydrochloric acid (1→25) is D-form.

(2) To 5 mL of L-Valine solution (1→1,000), add 1 mL of ninhydrin solution, and heat for 3 minutes. The color of this solution becomes reddish-purple to blue-purple.

Purity (1) Clarity and Color of Solution : 0.5 g of L-Valine is dissolved in 20 mL of water. The solution should be colorless and the turbidity should not be more than almost clear.

(2) pH : pH of L-Valine solution (1→30) should be within a range of 5.5 ~ 7.0.

(3) Specific Rotation : Dissolve 4 g of L-Valine, previously dried for 3 hours at 105°C and precisely weighed, and add 6 N hydrochloric acid to make 50 mL. When Optical rotation of this solution is measured, it should be $[\alpha]_D^{20} = +26.5 \sim +29.0^\circ$.

(4) Arsenic : It should be no more than 4.0 ppm tested by Arsenic Limit Test.

(5) Lead : When 5.0 g of L-Valine is tested by Atomic Absorption Spectrophotometry or Inductively Coupled Plasma Emission Spectroscopy, its content should not be more than 5.0 ppm.

(6) Chloride : When 0.5 g of L-Valine is tested by Chloride Limit Test, its content should not be more than the amount that corresponds to 0.3 mL of 0.01 N hydrochloric acid.

Loss on Drying When L-Valine is dried for 3 hours at 105°C, the weight loss should not be more than 0.3%.

Residue on Ignition When thermogravimetric analysis is done with L-Valine, the residue should not be more than 0.1%.

Assay Proceed as directed under Assay in 「Glycine」.

1 mL of 0.1 N perchloric acid = 11.71 mg of C₅H₁₁NO₂

Vanillin



Chemical Formula: $C_8H_8O_3$

Molecular Weight: 152.15

Synonyms: Vanillic aldehyde

CAS No.: 121-33-5

Compositional Specifications of Vanillin

Content Vanillin, when calculated on the dried basis, should contain within a range of 97.0 ~ 103.0% of vanillin ($C_8H_8O_3$).

Description Vanillin occurs as white to light yellow needles or crystalline powder, having a vanilla-like scent and taste.

Identification (1) To the saturated solution of Vanillin, add 3 drops of ferric chloride solution. Then the color becomes blue-purple. Heat the solution to about 80°C for 5 minutes. The color of the solution changes to brown, and a white to gray-white precipitate is formed.

(2) To 1 g of Vanillin, add 5 mL of sodium hydrogen sulfite solution, dissolve while warming in hot water and shaking, add 10 mL of diluted sulfuric acid, warm at 60 ~ 70°C for approximately 5 minutes, and allow to stand. Crystals are precipitated.

Purity (1) Melting Point : Melting point of Vanillin should be within a range of 81 ~ 83°C.

(2) Clarity and Color of Solution : When 1 g of Vanillin is dissolved in 20 mL of water by heating at 80°C, the solution should be clear.

(3) Arsenic : It should be no more than 4.0 ppm tested by Arsenic Limit Test.

(4) Lead : When 5.0 g of Vanillin is tested by Atomic Absorption Spectrophotometry or Inductively Coupled Plasma Emission Spectroscopy, its content should not be more than 2.0 ppm.

Loss on Drying When Vanillin is dried for 4 hours in a vacuum desiccator(silica gel), the weight loss should not be more than 0.5%.

Residue on Ignition When thermogravimetric analysis is done with Vanillin, the residue should not be more than 0.05%.

Assay Accurately weigh about 1 g of Vanillin, and proceed as directed under Hydroxylamine Method 2 in Aldehyde and Ketone Content (3) in Flavoring Substances Tests, using 15 minutes as the time to allow to stand.

1 mL of 0.5 N hydrochloric acid = 76.07 mg of $C_8H_8O_3$

Vitamin A in Oil

Definition Vitamin A in Oil is a fatty oil obtained from the fresh liver, pyloric appendage, other parts of marine animals, its vitamin A (retinol) concentrate or vitamin A fatty acid ester (retinol fatty acid ester), or such substances dissolved in edible fats and oils.

Compositional Specifications of Vitamin A in Oil

Content 1 g of Vitamin A in Oil should contain not less than 30 mg of vitamin A, and 90.0 ~ 120.0% of the declared content of vitamin A. 300 mg of vitamin A is equivalent to 1,000,000 international units.

Description Vitamin A in Oil occurs as a light yellow to reddish-light yellow oily substance having a slight, characteristic odor.

Identification (1) Dissolve 50 mg of Vitamin A in Oil in chloroform to obtain the solution containing about 3 µg of vitamin A per mL. To 1 mL of the solution, add 5 mL of antimony trichloride solution. A blue color develops and immediately fades.

(2) Dissolve 50 mg of Vitamin A in Oil in isopropyl alcohol for vitamin A determination to obtain the solution containing about 3 µg of vitamin A per 1 mL. The solution exhibits an absorption maximum at a wavelength of 327 ± 1 nm.

Purity (1) Free Acid : 2 g of Vitamin A in Oil is dissolved in 20 mL of alcohol. Acid value of this solution is tested by Acid Value in Flavoring Substance Test. It should not be more than 2.8.

(2) Lead : When 5.0 g of Vitamin A in Oil is tested by Atomic Absorption Spectrophotometry or Inductively Coupled Plasma Emission Spectroscopy, its content should not be more than 2.0 ppm.

Assay Accurately weigh an amount of Vitamin A in Oil corresponding to not less than 0.15 mg as vitamin A and containing not less than 1 g of fats and oils, transfer into a flask, and add 30 mL of aldehyde-free alcohol and 1 mL of a solution of pyrogallol in alcohol (1→10). Add 3 mL of potassium hydroxide solution (9→10), equip with a reflux condenser, and heat in a water bath for 30 minutes to saponify. Cool quickly to ordinary temperature. add 30 mL of water, transfer into separating funnel. Wash the flask with 10 mL of water and then 40 mL of ether for vitamin A determination, transfer the washings into the separating funnel, shake well, and allow to stand. Transfer the aqueous layer into a separatory funnel and extract twice with 30 mL of ether for vitamin A determination. Wash the ether extract with 50 mL of water until the aqueous layer is not colorized with phenolphthalein solution. Allow to stand for 10 minutes. Remove water completely and transfer the ether layer into an Erlenmeyer flask. Wash the separatory funnel twice with 10 mL of ether for vitamin A determination each time and transfer the washings to the Erlenmeyer flask above. Add 5 g of anhydrous sodium sulfate, shake, and decant the ether extract into an Erlenmeyer flask. Wash the remaining sodium sulfate more than twice with 10 mL of ether for vitamin A determination each time, and transfer the washings into the Erlen Meyer flask above. Concentrate the ether extract to approximately 1 mL using a Guternadanish concentrator while shaking in a water bath at 45°C, immediately dissolve in isopropyl alcohol for vitamin A determination, diluting exactly to obtain the solution containing approximately 3µg of vitamin A per 1µl. Use this

solution as the test solution. Measure absorbances at wavelengths of 310 nm, 325 nm, and 334 nm, respectively, and calculate the content by the following formula. In this case, ether and isopropyl for vitamin A determination are used :

$$\text{Content of vitamin A (mg)} = E_{1\text{cm}}^{1\%}(325\text{nm}) \times 0.549$$

$$E_{1\text{cm}}^{1\%}(325\text{nm}) = \frac{A_{325}}{W/l} \times \frac{V}{100} \times f$$

$$f = 6.815 - 2.555 \left(\frac{A_{310}}{A_{325}} \right) - 4.260 \left(\frac{A_{334}}{A_{325}} \right)$$

A : Absorbance at each wavelength

W : Weight (g) of the sample in V mL of the test solution.

f : Correction factor (when it is within 0.970 ~ 1.030, 1 is used instead.)

V : Total volume (mL) of the test solution,

l : Path length of the solution (cm)

Storage Standards of Vitamin A in Oil

Place in a light-resistant hermetic container, replace the air with an inert gas, and store.

Vitamin B₁₂



Chemical Formula: $C_{63}H_{88}CoN_{14}O_{14}P$

Molecular Weight: 1,355.40

CAS No.: 68-19-9

Definition Cyanocobalamin is obtained by separating the cultures of *Streptomyces*, *Bacillus*, *Flavobacterium*, *Propionibacterium*, and *Rhizobium*. The major component is Cyanocobalamin.

Compositional Specifications of Cyanocobalamin

Content If Cyanocobalamin is converted to a dehydrated form, it should contain not less than 96.0% cyanocobalamin ($C_{63}H_{88}CoN_{14}O_{14}P$).

Description Cyanocobalamin is dark red crystallite or powder.

Identification (1) When absorbance of the Test Solution in Assay is measured, absorbance maximum are observed at 277~279 nm, 360~362 nm, and 548~552 nm. The ratio of A_{361}/A_{550} is 3.15~3.40.

(2) Approximately 1 mg of Cyanocobalamin and 50 mg of potassium pyrosulfate is transferred into a crucible, are melted by heating. After cooling, the lump is broken into small pieces with a glass rod. It is then dissolved in 3 mL of water by heating. After adding 1 drop of phenolphthalein TS, sodium hydroxide TS (1→10) is drop-wise added until the solution shows pale red color. When 500 mg of sodium acetate, 0.5 mL of dilute acetic acid, and 0.5 mL of sodium nitroso-2-naphthol-3,6-disulfonate solution (1→500) are added to the resultant solution, red or orange red color appears immediately. When 0.5 mL of hydrochloric acid is added and the solution is boiled for 1 minute, the red color persists.

(3) A 50 mL distillation flask (two neck / round bottom) is connected to a vertical condenser, of which the end is immersed in a test tube with 1 mL of 0.1 N sodium hydroxide solution. 1.5 ~ 2.0 mg of Cyanocobalamin is dissolved in 5 mL of water in the flask. 2.5 mL of hypophosphite is added to the flask, which is then gently boiled for 10 minutes under air. 1 drop of saturated ferrous ammonium

sulfate solution is added to the small test tube and 30 mg of sodium fluoride is added, which is gently boiled and cooled. Diluted sulfuric acid (1→7) is drop-wise added until the solution becomes clear. When 3 ~ 5 drops of diluted sulfuric acid (1→7) are added additionally, the solution turns blue or bluish green within a few minutes.

(4) 1 g of Cyanocobalamin dissolves in 80 mL of water. It is almost insoluble in ether, chloroform, or acetone.

Purity Analogous vitamin B₁₂: 1 mg of Cyanocobalamin is dissolved in 20 mL of water, which is transferred into a small separatory funnel. 4 mL of mixture of carbon tetrachloride and m-cresol (50:50) is added and mixed well for 1 minute by shaking. It is allowed to stand to separate phases. The lower phase is transferred into another separatory funnel, where 5 mL of diluted sulfuric acid (1→7) is added. The mixture is vigorously shaken. Two phases are separated, centrifuged if necessary. The supernatant should be colorless or should not be darker than the mixture of 0.15 mL of 0.1 N potassium permanganate solution and 250 mL water.

Loss on Drying Approximately 25 mg of Cyanocobalamin is accurately weighed and dried for 2 hours at 105°C under a decompression of 5 mm Hg or less. The loss on drying should not be more than 12%.

Assay Approximately 30 mg each of Cyanocobalamin and vitamin B₁₂ standard, previously measured losses on drying as method used in sample, is accurately measured and dissolved in water so that the total volume is 1,000 mL, respectively (Test Solution & Standard Solution). Absorbance of ET and ES for Test and Standard Solutions are measured at 361 nm with 1 cm path length.

$$\text{Amount of vitamin B}_{12}(\text{C}_{63}\text{H}_{88}\text{CoN}_{14}\text{O}_{14}\text{P})(\text{mg}) = \frac{\text{Weight of vitamin B}_{12}\text{standard (on dry basis) (mg)} \times E_T}{E_S}$$

Vitamin B₁ Dilaurylsulfate

Thiamine Dilaurylsulfate

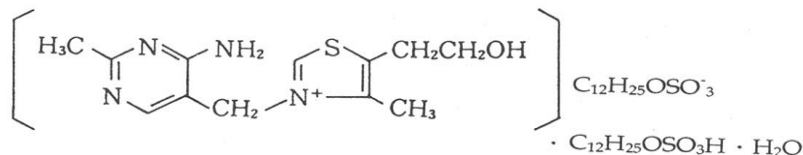

Chemical Formula: $C_{36}H_{68}O_9N_4S_3 \cdot H_2O$

Molecular Weight: 815.19

CAS No.: 39479-63-5

Compositional Specifications of Vitamin B₁ Dilaurylsulfate

Content Vitamin B₁ Dilaurylsulfate, when calculated on the dried basis, should contain within a range of 98.0 ~ 102.0% of Vitamin B₁ dilaurylsulfate ($C_{36}H_{68}O_9N_4S_3 \cdot H_2O$).

Description Vitamin B₁ Dilaurylsulfate occurs as colorless to white crystals or as a white crystalline powder. It is odorless or has a slight, characteristic odor.

Identification (1) To 1 g of Vitamin B₁ Dilaurylsulfate, add 30 mL of water and 15 mL of hydrochloric acid, which is boiled for approximately 4 hours with a reflux condenser. After cooling, it is extracted twice with 15 mL each of ether. Ether extracts are combined and washed with water. Ether is removed by evaporation in a water bath. The residue is dried for 15 minutes at 100°C and cooled. The melting point of Vitamin B₁ Dilaurylsulfate should be within a range of 20~28°C.

(2) To 0.1 g of Vitamin B₁ Dilaurylsulfate, add 20 mL of potassium chloride-hydrochloric acid solution boil for approximately 30 minutes cool, and filter. When take 1 mL of the filtrate, and add 1 mL of lead acetate solution and 1 mL of sodium hydroxide solution (1→10), it becomes yellow. The solution is heated in a water bath, and it turns brown. If it is further set-aside, black brown precipitate is formed.

(3) To 1 mL of the filtrate above (2), add 5 mL of 0.5 N sodium hydroxide solution, 0.5 mL of potassium ferricyanide solution, and 5 mL of n-butyl alcohol. It is tested by Identification (1) in 「Vitamin B₁ Hydrochloride」.

Purity (1) Chloride : To 0.25 g of Vitamin B₁ Dilaurylsulfate, add 30 mL of water, and shake, which is set-aside for 10 minutes. Add 6 mL of dilute nitric acid and filter and wash with water. Wash water is added to the filtrate, Test Solution. It is tested by Chloride Limit Test. Its content should not be more than the amount that corresponds to 0.4 mL of 0.01 N hydrochloric acid.

(2) Lead : When 5.0 g of Vitamin B₁ Dilaurylsulfate is tested by Atomic Absorption Spectrophotometry or Inductively Coupled Plasma Emission Spectroscopy, its content should not be more than 2.0 ppm.

Loss on Drying When Vitamin B₁ Dilaurylsulfate is dried for 24 hours in a vacuum desiccator (silica gel),

the weight loss should be not more than 2%.

Residue on Ignition When thermogravimetric analysis is done with Vitamin B₁ Dilaurylsulfate, the residue should be not more than 0.3%.

Assay Accurately weigh about 0.12 g of Vitamin B₁ Dilaurylsulfate, previously dried, add 40 mL of potassium chloride-hydrochloric acid solution, heat in a water bath for 30 minutes while shaking occasionally, cool, filter, wash with 50 mL of water, combine the filtrate and the washings, and add water to make 100 mL. Measure exactly 2 mL of this solution, and add water to make 50 mL. Use this solution as the Test Solution. Accurately weigh about 0.1 g of Vitamin B₁ Hydrochloride Reference Standard (measure previously the water content in the same manner as for 「Vitamin B₁ Hydrochloride」), dissolve in 40 mL of potassium chloride hydrochloric acid solution, and add water to make exactly 200 mL. 2 mL of this solution, accurately weighed, is diluted to 50 mL with water, Standard Solution. Quantitative analysis is carried out with test solution and standard solution following 「Vitamin B₁ Hydrochloride」.

$$\text{Contents(\%)} = \frac{A_T - A_T'}{A_S - A_S'} \times \frac{\text{Weight of Vitamin B}_1 \text{ Hydrochloride reference standard calculated on the anhydrous basis(g)}}{\text{Weight of the sample(g)}} \times \frac{2.41}{7} \times \frac{10}{0}$$

Vitamin B₁ Hydrochloride

Thiamine Hydrochloride



Chemical Formula: C₁₂H₁₇ON₄ClS·HCl

Molecular Weight: 337.29

CAS No.: 67-03-8

Compositional Specifications of Vitamin B₁ Hydrochloride

Content Vitamin B₁ Hydrochloride, when calculated on the anhydrous dried basis, should contain within a range of 98.0~102.0% of Vitamin B₁ hydrochloride (C₁₂H₁₇ON₄ClS.HCl).

Description Vitamin B₁ Hydrochloride occurs as white, fine crystals or crystalline powder. It is odorless or has a slight, characteristic odor.

Identification (1) Dissolve 5 mg of Vitamin B₁ Hydrochloride in a mixture of 5 mL of 0.5 N sodium hydroxide solution and 0.5 mL of potassium ferricyanide solution, add 5 mL of n-butyl alcohol, shake vigorously for 2 minutes, allow to stand, and observe under ultraviolet light. The upper layer emits a blue-purple fluorescence. The fluorescence disappears upon acidifying the solution. It reappears on making the solution alkaline.

(2) Dissolve 5 mg of Vitamin B₁ Hydrochloride in a mixture of 1 mL of lead acetate solution and 1 mL of sodium hydroxide solution (1→10). The color of the solution becomes yellow. Warm in a water bath. It changes to brown. Then allow to stand. A black brown precipitate is formed.

(3) Vitamin B₁ Hydrochloride responds to the test for Chloride in Identification.

Purity (1) Clarity and Color of Solution : When dissolve 1 g of Vitamin B₁ Hydrochloride in water to make 10 mL, the solution should not be darker than the solution added water to 1.5 mL of 0.1 N potassium dichromate solution and made to 1,000 mL.

(2) pH : pH of Vitamin B₁ Hydrochloride solution (1→100) should be within a range of 2.7 ~ 3.4.

(3) Sulfate : When 1.5 g of Vitamin B₁ Hydrochloride is tested by Sulfate Limit Test, its content should not be more than the amount that corresponds to 0.35 mL of 0.01 N sulfuric acid.

(4) Lead : When 5.0 g of Vitamin B₁ Hydrochloride is tested by Atomic Absorption Spectrophotometry or Inductively Coupled Plasma Emission Spectroscopy, its content should not be more than 2.0 ppm.

(5) Nitrate: 0.02 g of Vitamin B₁ Hydrochloride is dissolved in water to make to 20 mL, and 2 mL of sulfuric acid is added. After shaking it to mix, cool it. When 2 mL of ferrous sulfate solution is added to make layer, the interface layer of two solutions should not produce a band of brown color.

Water Content Vitamin B₁ Hydrochloride is tested by the Back Titration Method in Water Content

Determination (Karl-Fischer Method). The water content should not be more than 5%.

Residue on Ignition When thermogravimetric analysis is done with Vitamin B₁ Hydrochloride, the residue should not be more than 0.2%.

Assay Accurately weigh about 0.1 g each of Vitamin B₁ Hydrochloride and Vitamin B₁ Hydrochloride Reference Standard (measure previously the water content in the same manner as for Vitamin B₁ Hydrochloride), separately dissolve each in hydrochloric acid (1→10,000) to make exactly 200 mL, take 2 mL each, and add hydrochloric acid (1→10,000) to make 50 mL each. Use these solutions as the Test Solution and the Standard Solution, respectively. Measure exactly 5 mL of the test solution, and transfer into test tubes T and T' with ground-glass stoppers. Transfer 3 mL of cyanogen bromide for Vitamin B₁ Assay, exactly measured, into T, shake, add quickly 5 mL of sodium hydroxide solution (1→10), exactly measured, and shake again. Transfer 5 mL of sodium hydroxide solution (1→10), exactly measured, into T'. shake, add 3 mL of cyanogen bromide IS for Vitamin B₁ Assay, exactly measured, and shake again. Separately, measure exactly 5 mL of the standard solution, transfer into test tubes S and S' with ground-glass stoppers, and proceed in the same manner as for the test solution. Measure absorbances A_T, A_{T'}, A_S and A_{S'} of respective solutions at a wavelength of 368 nm using water as the reference solution, and calculate the content by the following formula:

Bromine Cyanide solution for Vitamin B₁ Assay : To 2 mL of bromine, add 100 mL of ice cold water and shake thoroughly, and add drop-wise ice cold potassium thiocyanide solution (1→10) until the color of bromine is completely decolorized.

$$\text{Contents(\%)} = \frac{A_T - A_{T'}}{A_S - A_{S'}} \times \frac{\text{Weight of Vitamin B}_1 \text{ Hydrochloride reference standard calculated on the anhydrous basis(g)}}{\text{Weight of the sample(g)}} \times 100$$

Vitamin B₁ Mononitrate

Thiamine mononitrate

Chemical Formula: C₁₂H₁₇O₄N₅S

Molecular Weight: 327.37

CAS No.: 532-43-4

Compositional Specifications of Vitamin B₁ Mononitrate

Content Vitamin B₁ Mononitrate, when calculated on the dried basis, should contain within a range of 98.0 ~ 102.0% of Vitamin B₁ Mononitrate (C₁₂H₁₇O₄N₅S).

Description Vitamin B₁ Mononitrate occurs as white to white crystalline powder. It is odorless or has a slight, characteristic odor.

Identification (1) Proceed as directed under Identification (1) and (2) in 「Vitamin B₁ Hydrochloride」.
(2) Vitamin B₁ Mononitrate responds to the test for Nitrate in Identification.

Purity (1) pH : pH of Vitamin B₁ Mononitrate solution(1→50) should be within a range of pH 6.5 ~ 8.0.
(2) Chloride : When 0.25 g of Vitamin B₁ Mononitrate is tested by Chloride Limit Test, its content should not be more than the amount that corresponds to 0.4 mL of 0.01 N hydrochloric acid.
(3) Lead : When 5.0 g of Vitamin B₁ Mononitrate is tested by Atomic Absorption Spectrophotometry or Inductively Coupled Plasma Emission Spectroscopy, its content should not be more than 2.0 ppm.

Loss on Drying When Vitamin B₁ Mononitrate is dried for 2 hours at 105°C, the weight loss should not be more than 1%.

Residue on Ignition When thermogravimetric analysis is done with Vitamin B₁ Mononitrate, the residue should not be more than 0.2%.

Assay Proceed as directed under Assay in 「Vitamin B₁ Hydrochloride」.

$$\text{Contents(\%)} = \frac{A_T - A_R}{A_S - A_S} \times \frac{\text{Weight of Vitamin B}_1 \text{ Hydrochloride reference standard calculated on the anhydrous basis(g)}}{\text{Weight of the sample(g)}} \times 0.9706 \times \frac{10}{0}$$

Vitamin B₁ Naphthalene-1,5-disulfonate

Thiamine Naphthalene-1,5-disulfonate



Chemical Formula: C₂₂H₂₄O₇N₄S₃·H₂O

Molecular Weight: 570.68

CAS No.: 573-09-1

Compositional Specifications of Vitamin B₁ Naphthalene-1,5-disulfonate

Content Vitamin B₁ Naphthalene-1,5-disulfonate, when calculated on the dried basis, should contain within a range of 98.0 ~ 102.0% of thiamine naphthalene-1,5-disulfonate (C₂₂H₂₄O₇N₄S₃ = 552.66).

Description Vitamin B₁ Naphthalene-1,5-disulfonate occurs as a white, fine crystalline powder. It is odorless or has a slight, characteristic odor.

Identification (1) Dissolve 10 mg of Vitamin B₁ Naphthalene-1,5-disulfonate in 100 mL of 0.001 N hydrochloric acid. Take 5 mL of the solution, and add 0.001 N hydrochloric acid to make 100 mL. The solution exhibits an absorption maximum at a wavelength of 226 ± 1 nm.

(2) Proceed as directed under Identification (1) and (2) in 「Vitamin B₁ Hydrochloride」.

Purity (1) Chloride : To 0.25 g of Vitamin B₁ Naphthalene-1,5-disulfonate, add 30 mL of water, and shake which is then set-aside for 10 minutes. Add 6 mL of dilute nitric acid and filter. When the filtrate is tested by Chloride Limit Test, its content should not be more than the amount that corresponds to 0.4 mL of 0.01 N hydrochloric acid.

(2) Lead : When 5.0 g of Vitamin B₁ Naphthalene-1,5-disulfonate is tested by Atomic Absorption Spectrophotometry or Inductively Coupled Plasma Emission Spectroscopy, its content should not be more than 2.0 ppm.

Loss on Drying When Vitamin B₁ Naphthalene-1,5-disulfonate is dried for 2 hours at 105°C, the weight loss should be not more than 5%.

Residue on Ignition The amount of residue of Vitamin B₁ Naphthalene-1,5-disulfonate should not be more than 0.2%.

Assay Accurately weigh about 0.16 g of Vitamin B₁ Naphthalene-1,5-disulfonate, previously dried, add 25 mL of diluted hydrochloric acid, heat in a water bath, cool, and add water to make exactly 1,000 mL. Take 2 mL of this solution, and proceed as directed under Assay in 「Vitamin B₁ Hydrochloride」.

$$\text{Contents(\%)} = \frac{A_T - A_R}{\text{reference standard calculated on the anhydrous basis(g)}} \times \frac{\text{Weight of Vitamin B}_1 \text{ Hydrochloride}}{1.6386} \times \frac{10}{0}$$

$A_S - A_{S'}$

Weight of the sample(g)

Vitamin B₁ Rhodanate

Thiamine Thiocyanate



Chemical Formula: C₁₃H₁₇ON₅S₂·H₂O

Molecular Weight: 341.17

CAS No.: 14940-85-3

Compositional Specifications of Vitamin B₁ Rhodanate

Content Vitamin B₁ Rhodanate, when calculated on the dried basis, should contain within a range of 98.0 ~ 102.0% of Vitamin B₁ Rhodanate (C₁₃H₁₇ON₅S₂ = 323.45).

Description Vitamin B₁ Rhodanate occurs as white crystals or crystalline powder. It is odorless or has a slight, characteristic odor.

Identification (1) Proceed as directed under Identification (1) and (2) in 「Vitamin B₁ Hydrochloride」.

(2) A saturated solution of Vitamin B₁ Rhodanate responds to the test for thiocyanide salt in Identification.

Purity (1) Chloride : To 0.3 g of Vitamin B₁ Rhodanate, add 1.5 mL of water, 0.3 g of ammonium nitrate, and 0.9 mL of sodium hydroxide solution (2→5). Then add drop-wise 3 mL of hydrogen peroxide gradually while shaking. Heat in a water bath for 30 minutes while shaking occasionally, cool, and add 3 mL of diluted nitric acid (2→3) and water to make 50 mL. Add 0.1 mL of dextrin solution (1→50) and 0.5 mL of silver nitrate solution. Then allow to stand for 5 minutes. The solution should be not more turbid than the reference solution prepared as follows. Take 0.5 mL of 0.01 N hydrochloric acid and proceed in the same manner as for the test solution.

(2) Lead : When 5.0 g of Vitamin B₁ Rhodanate is tested by Atomic Absorption Spectrophotometry or Inductively Coupled Plasma Emission Spectroscopy, its content should not be more than 2.0 ppm.

Loss on Drying When Vitamin B₁ Rhodanate is dried for 2 hours at 105°C, the weight loss should not be more than 6%.

Residue on Ignition When thermogravimetric analysis is done with Vitamin B₁ Rhodanate, the residue should not be more than 0.2%.

Assay Proceed as directed under Assay in 「Vitamin B₁ Hydrochloride」.

$$\text{Contents(\%)} = \frac{A_T - A_T'}{A_T - A_T'} \times \frac{\text{Weight of Vitamin B}_1 \text{ Hydrochloride}}{\text{reference standard calculated on the anhydrous basis(g)}} \times \frac{0.95}{9} \times \frac{10}{0}$$

$A_s - A_{s'}$

Weight of the sample(g)

Vitamin B₂

Riboflavin



Chemical Formula: C₁₇H₂₀N₄O₆

Molecular Weight: 376.38

Synonyms: Lactoflavin

INS No.: 101(i)

CAS No.: 83-88-5

Compositional Specifications of Vitamin B₂

Content Vitamin B₂, when calculated on the dried basis, should contain within a range of 98.0 ~ 102.0% of Vitamin B₂ (C₁₇H₂₀N₄O₆).

Description Vitamin B₂ occurs as yellow to light yellow crystals or crystalline powder, having a slight odor and a bitter taste.

Identification 1 mg of Vitamin B₂ is dissolved in water to make 100 mL. The solution is light yellow-green in color and emits a strong yellowish green fluorescence. The fluorescence disappears on addition of diluted hydrochloric acid or sodium hydroxide solution.

Purity (1) Specific Rotation : Dry Vitamin B₂, light-shielded, for 2 hours at 105°C. Dissolve 50 mg of Vitamin B₂, precisely weighed, in 2 mL of 0.1 N sodium hydroxide solution. Add 5 mL of freshly boiled and cooled water, and add 2 mL of ethanol while shaking sufficiently. Add freshly boiled and cooled water to make exactly 10 mL. When Optical rotation of this solution is measured within 30 minutes, should be within a range of $[\alpha]_D^{20} = -120 \sim -140^\circ$.

(2) Lumiflavin : To 25 mg of Vitamin B₂, add 10 mL of alcohol-free chloroform, shake for 5 minutes, and filter. The color of the filtrate should not darker than that of the solution prepared by adding water to 3 mL of 0.1 N potassium dichromate to make 1,000 mL.

(3) Arsenic : It should be no more than 4.0 ppm tested by Arsenic Limit Test.

(4) Lead : When 5.0 g of Vitamin B₂ is tested by Atomic Absorption Spectrophotometry or Inductively

Coupled Plasma Emission Spectroscopy, its content should not be more than 2.0 ppm.

(5) Cadmium : When 5.0g of Vitamin B₂ is tested by Atomic Absorption Spectrophotometry or Inductively Coupled Plasma Emission Spectroscopy, its content should not be more than 1.0 ppm.

(6) Mercury : When Vitamin B₂ is tested by Mercury Limit Test, its content should not be more than 1.0 ppm.

(7) Unsulfonated Primary Aromatic Amines : When G. Unsulfonated Primary Aromatic Amines in Coloring Matter Tests is done, the content should not be more than 0.01% as Aniline.

Loss on Drying When Vitamin B₂ is dried for 2 hours at 105°C, the weight loss should not be more than 1.5%.

Residue on Ignition When thermogravimetric analysis is done with Vitamin B₂, the amount of residue should not be more than 0.3%.

Assay Dissolve 0.015g of Vitamin B₂, previously dried and accurately weighed, in 800 mL of diluted glacial acetic acid (1→400) by heating at 60~70°C, cool, and add water to make exactly 1,000 mL. Use this solution as the test solution. Prepare the standard solution, using Riboflavin Reference Standard and proceeding in the same manner as the sample. Using water as the reference solution, measure absorbances A_T and A_S of the test solution and standard solution, respectively, at a wavelength of 445 nm, add 0.02 g of sodium hydrosulfite to solution of each. Decolorize by shaking well, and immediately measure absorbances A_T' and A_S'. Calculate the content by the following formula. Avoid direct sunlight during the procedure. and use light-shielded containers.

$$\text{Content(\%)} = \text{Weight of Vitamin B}_2 \text{ Standard(mg)} \times \frac{A_T - A_T'}{A_S - A_S'} \times \frac{100}{\text{Weight of sample(mg)}}$$

Vitamin B₂ Phosphate Sodium

Riboflavin 5'-Phosphate Sodium



Chemical Formula: C₁₇H₂₀N₄NaO₉P·0 ~ 2H₂O

Molecular Weight: 514.38

INS No.: 101(ii)

Synonyms: Riboflavin 5'-phosphate ester
monosodium salt

CAS No.: 103-40-
5(anhydrous)

Compositional Specifications of Vitamin B₂ Phosphate Sodium

Content Vitamin B₂ Phosphate Sodium, when calculated on the anhydrous basis, should contain not less than 95.0% of Vitamin B₂ Phosphate Sodium (C₁₇H₂₀N₄NaO₉P = 478.33).

Description Vitamin B₂ Phosphate Sodium occurs as yellow to orange crystals or crystalline powder. It is almost odorless and has a bitter taste.

Identification (1) Proceed as directed under Identification in 「Vitamin B₂」.

(2) The solution, which is made by decomposition of 50 mg of Vitamin B₂ Phosphate Sodium as B. Semi-micro Kjeldahl Method in Nitrogen Determination, responds to the test for Sodium Salt and Phosphate in Identification.

Purity (1) Clarity and Color of Solution : When 0.2 g of Vitamin B₂ Phosphate Sodium is dissolved in 10 mL of water, the solution should be clear.

(2) Specific Rotation : Approximately 0.3 g of Vitamin B₂ Phosphate Sodium is precisely weighed and dissolved in 5 N hydrochloric acid to make 20 mL. Optical rotation of Vitamin B₂ Phosphate Sodium is measured and converted to a value of anhydrous. It should be within a range of $[\alpha]_D^{20} = +38 \sim +43^\circ$.

(3) Lumiflavin : To 35 mg of Vitamin B₂ Phosphate Sodium, add 10 mL of alcohol-free chloroform, shake for 5 minutes, and filter. The color of the filtrate should not be darker than that of the solution prepared by adding water to 3.0 mL of 0.1 N potassium dichromate to make 1,000 mL.

- (4) Arsenic : It should be no more than 4.0 ppm tested by Arsenic Limit Test.
- (5) Lead : When 5.0 g of Vitamin B₂ Phosphate Sodium is tested by Atomic Absorption Spectrophotometry or Inductively Coupled Plasma Emission Spectroscopy, its content should not be more than 2.0 ppm.
- (6) Cadmium : When 5.0g of Vitamin B₂ Phosphate Sodium is tested by Atomic Absorption Spectrophotometry or Inductively Coupled Plasma Emission Spectroscopy, its content should not be more than 1.0 ppm.
- (7) Mercury : When Vitamin B₂ Phosphate Sodium is tested by Mercury Limit Test, its content should not be more than 1.0 ppm.
- (8) Unulfonated Primary Aromatic Amines : When G. Unulfonated Primary Aromatic Amines in Coloring Matter Tests is done, the content should not be more than 0.007% as Aniline. 10 mg of aniline is precisely weighed and dissolved in 30 mL of diluted hydrochloric acid (3→10), which is diluted to 100 mL with water. To 1.4 mL of this solution, hydrochloric acid(1→10) is added to make 100 mL, reference solution.

Water Content 25 mL of methanol (for Karl-Fischer)-ethylene glycol solution (for Karl-Fischer) (1:1) is transferred into a dried titration flask and titrated with Karl-Fischer solution until the end point. 0.1 g of Vitamin B₂ Phosphate Sodium is precisely weighed and immediately placed into a titration flask. It is then titrated by the Back Titration Method in Water Content Method (Karl-Fischer Method). Water content should not be more than 10%.

Assay Accurately weigh about 20 mg of Vitamin B₂ Phosphate Sodium, and proceed as directed under Assay in 「Vitamin B₂」. Calculate the content by the following formula. Avoid direct sunlight during the procedure and use light-shielded containers.

$$\text{Contents(\%)} = \text{Weight of Vitamine B2 standard (mg)} \times \frac{A_T - A_T'}{A_S - A_S'} \times \frac{1.271}{\text{Weight of Sample(mg)}} \times \frac{100}{100 - \text{Water Contents(\%)}} \times 100$$

Vitamin B₆ Hydrochloride

Pyridoxine Hydrochloride

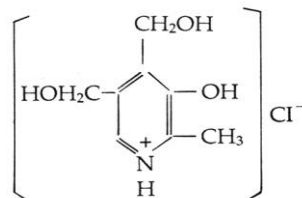

Chemical Formula: C₈H₁₁O₃N·HCl

Molecular Weight: 205.64

CAS No.: 58-56-0

Compositional Specifications of Vitamine B₆ Hydrochloride

Content Vitamin B₆ Hydrochloride, when calculated on the dried basis, should contain not less than 98.0% of Vitamin B₆ Hydrochloride (C₈H₁₁O₃N.HCl)

Description Vitamin B₆ Hydrochloride occurs as white to light yellow crystals or crystalline powder. It is odorless.

Identification (1) To 1 mL of Vitamin B₆ Hydrochloride solution (1→10,000), add 2 mL of a solution of 2,6-dibromoquinone chloroamide in ethanol (1→4,000) and 1 drop of ammonia solution. A blue color develops. When 1 mL of saturated boric acid solution is added before the test, and the same test is carried out, blue color does not develop.

(2) Vitamin B₆ Hydrochloride responds to the test for Chloride in Identification.

Purity (1) Melting Point : Melting point of Vitamin B₆ Hydrochloride should be within a range of 203 ~ 209°C.

(2) pH : pH of Vitamin B₆ Hydrochloride solution (0.5→25) should be within a range of 2.5~3.5.

(3) Lead : When 5.0 g of Vitamin B₆ Hydrochloride is tested by Atomic Absorption Spectrophotometry or Inductively Coupled Plasma Emission Spectroscopy, its content should not be more than 2.0 ppm.

(4) Chloride : 0.5 g of Vitamin B₆ Hydrochloride is dissolved in 50 mL of methanol. Add 5 mL of glacial acetic acid and 2~3 drops of eosin Y solution. When it is titrated by 0.1 N silver nitrate solution, the content which is calculated on the dried basis should be 16.9~17.6%.

1 mL of 0.1 N silver nitrate solution = 3.545mg Cl

Eosin Y solution : 50 mg of eosin Y is dissolved in 10 mL of water.

Loss on Drying When Vitamin B₆ Hydrochloride is dried for 4 hours in a vacuum desiccator, the weight loss should not be more than 0.5%.

Residue on Ignition When thermogravimetric analysis is done with Vitamin B₆ Hydrochloride, the residue should not be more than 0.1%.

Assay Accurately weigh about 0.4 g of Vitamin B₆ Hydrochloride, dissolve in 60 mL of glacial acetic acid (for non-aqueous titration) and 10 mL of mercury II acetate solution (for non-aqueous titration). Titrate with 0.1 N perchloric acid (indicator : 1 mL of crystal violet-glacial acetic acid solution). Separately, carry out a blank test.

1 mL of 0.1 N perchloric acid = 20.56 mg C₈H₁₁O₃N.HCl

Vitamin C

L-Ascorbic Acid

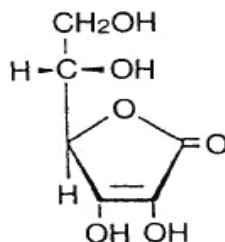

Chemical Formula: $C_6H_8O_6$

Molecular Weight: 176.13

Synonyms: Ascorbic acid

INS No.: 300

CAS No.: 50-81-7

Compositional Specifications of Vitamin C

Content Vitamin C, when calculated on the dried basis, should contain no less than 99.0% of Vitamin C ($C_6H_8O_6$).

Description Vitamin C occurs as white or light yellow crystals, crystalline powder or powder. It is odorless and has an acid taste.

Identification (1) Melting point of Vitamin C should be within a range of 187~192°C.

(2) To 2 mL of Vitamin C solution (1→100), 5 ~ 6 drops of sodium nitroprusside solution are added. When 1 drop of sodium hydroxide solution is added, the solution turns blue immediately.

(3) Dissolve 0.1 g of Vitamin C in 100 mL of metaphosphoric acid solution (1→50), and add drop-wise iodine solution until a slightly yellowish color develops. Add 1 drop each of cupric sulfate solution (1→1,000) and pyrrole. and heat in a water bath at 50 ~ 60°C for 5 minutes. A blue to bluish green color develops.

(4) To 10 mL of Vitamin C solution (1→100), add 1 mL of potassium permanganate solution, and then the color disappears immediately.

(5) To 5 mL of Vitamin C solution (1→100), add 0.3 mL of sodium hydroxide solution and 2 drops of uranyl acetate solution, and then the solution turns brown. When 2 mL of sodium hydroxide solution is added, it changes to light yellow.

Purity (1) Specific Rotation : Approximately 1 g of Vitamin C is precisely weighed and dissolved in freshly boiled and cooled water to make 10 mL. Optical rotation of this solution, when calculated on the dried basis, should within a range of $[\alpha]_D^{20} = +20.5 \sim +21.5^\circ$.

(2) Arsenic : It should be no more than 4.0 ppm tested by Arsenic Limit Test.

(3) Lead : When 5.0 g of Vitamin C is tested by Atomic Absorption Spectrophotometry or Inductively

Coupled Plasma Emission Spectroscopy, its content should not be more than 2.0 ppm.

(4) Mercury : When Vitamin C is tested by Mercury Limit Test, its content should not be more than 1.0 ppm.

Loss on Drying When Vitamin C is dried for 3 hours in a vacuum desiccator (silica gel), the weight loss should not be more than 0.4%.

Residue on Ignition When thermogravimetric analysis is done with Vitamin C, the amount of residue should not be more than 0.1%.

Assay Dissolve 0.2 g of Vitamin C, previously dried and accurately weighed, in 50 mL of metaphosphoric acid solution (1→50). Titrate with 0.1 N iodine solution (indicator : starch solution).

1 mL of 0.1 N iodine solution = 8.806 mg of $C_6H_8O_6$

Vitamin D₂

Calciferol



Chemical Formula: C₂₈H₄₄O

Molecular Weight: 396.66

CAS No.: 50-14-6

Compositional Specifications of Vitamin D₂

Description Vitamin D₂ is white crystal and odorless.

Identification (1) 50 mg of Vitamin D₂ is dissolved in 1 mL of anhydrous pyridine, where a solution of 50 mg 3,5-dinitro benzoyl in 1 mL anhydrous pyridine is added and heated for 10 minutes in a water bath. After cooling, 5 mL of water is added to form precipitates, which are then filtered and washed with water. Precipitates are twice recrystallized in acetone and then dried for 2 hours in a vacuum desiccator (sulfuric acid). Melting point should be within a range of 147~149°C.

(2) Dissolve 0.5 mg of Vitamin D₂ in 5mL of chloroform, add 0.3 mL of anhydrous acetic acid and 0.1 mL of sulfuric acid and shake. The color of this mixture turns red then violet, blue and finally green.

Purity (1) Specific Rotation : Approximately 0.3 g of Vitamin D₂ is precisely weighed and dissolved in ethanol to make 20 mL. The optical rotation of this solution should be within a range of $[\alpha]_D^{20} = +102 \sim +107^\circ$.

(2) Specific Absorbance : Specific absorbance is measured at 265nm with a solution of Vitamin D₂ in ethanol (aldehyde free). It should be $E_{1cm}^{1\%} = 445 \sim 485$ at 265 nm.

(3) Ergosterol : 10 mg of Vitamin D₂ is dissolved in 2 mL of 90% ethanol. 20 mg of digitonin is dissolved in 2 mL of 90% ethanol. Two solutions are mixed and kept for 18 hours. Precipitates should not be formed in this solution.

(4) Melting Point : Melting point of Vitamin D₂ should be within a range of 115~119°C.

Storage Standards of Vitamin D₂

Vitamin D₂ should be preserved in a light-shielded hermetic container filled with nitrogen in a cool place.

Vitamin D₃

Cholecalciferol



Chemical Formula: C₂₇H₄₄O

Molecular Weight: 384.65

CAS No.: 67-97-0

Compositional Specifications of Vitamin D₃

Description Vitamin D₃ occurs as white crystals. It is odorless.

Identification (1) Proceed as directed under Identification (1) in 「Vitamin D₂」. The melting point should be within a range of 133 ~ 135°C.

(2) Proceed as directed under Identification (2) in 「Vitamin D₂」.

Purity (1) Specific Rotation : Approximately 0.1 g of Vitamin D₃ is precisely weighed and dissolved in ethanol to make 200 mL. Optical rotation of this solution should be within a range of $[\alpha]_D^{25} = +103 \sim +112^\circ$.

(2) Specific Absorbance : Specific absorbance is measured at 265 nm with a solution of Vitamin D₃ in aldehyde free ethanol. It should be $E_{1\%}^{1\text{cm}} = 450 \sim 490$.

(3) 7-Dehydrocholesterol : Dissolve 10 mg of Vitamin D₃ in 2 mL of 90% ethanol, and add the solution prepared by dissolving 20 mg of digitonin in 2 mL of 90% ethanol, and allow to stand for 18 hours. Precipitate should not be formed.

(4) Melting Point : Melting point of Vitamin D₃ should be within a range of 84 ~ 89°C.

Storage Standards of Vitamin D₃

Vitamin D₃ should be preserved in a light-shielded hermetic container filled with nitrogen in a cool place.

Vitamin E

d,l- α -Tocopherol



Chemical Formula: $C_{29}H_{50}O_2$

Molecular Weight: 430.72

Synonyms: Alpha-tocopherol

INS No.: 307c

CAS No.: 2074-53-5

Compositional Specifications of Vitamin E

Content Vitamin E should contain not less than 96.0% of Vitamin E ($C_{29}H_{50}O_2$).

Description Vitamin E is yellow to brown, viscous and transparent liquid. It is odorless.

Identification Dissolve 10 mg of Vitamin E in 10 mL of anhydrous ethanol, add 2 mL of nitric acid, and heat at 75°C for 15 minutes. The color of the solution becomes red ~ orange.

- Purity**
- (1) Refractive Index : Refractive Index n_D^{20} of Vitamin E should be within a range of 1.503 ~ 1.507.
 - (2) Clarity and Color of Solution : When 0.1 g of Vitamin E is dissolved in 10 mL of anhydrous alcohol, it should be clear.
 - (3) Specific Absorbance : Accurately weigh about 10 mg of Vitamin E, and dissolve in anhydrous alcohol to make exactly 200 mL, and measure the absorbance a cell with 1 cm thickness at 292 nm. It should be within a range of $E_{1cm}^{1\%} = 71.0 \sim 76.0$.
 - (4) Arsenic : It should be no more than 4.0 ppm tested by Arsenic Limit Test.
 - (5) Lead : When 5.0 g of Vitamin E is tested by Atomic Absorption Spectrophotometry or Inductively Coupled Plasma Emission Spectroscopy, its content should not be more than 2.0 ppm.

Residue on Ignition When thermogravimetric analysis is done with Vitamin E, the amount of residue should not be more than 0.1%.

Assay Accurately weigh approximately 50 mg of Vitamin E, dissolve in 100 mL of sulfuric acid in ethyl alcohol mixture (3→200), add 20 mL of water, and titrate with 0.01 N ceric ammonium sulfate solution while stirring well (indicator : 2 drops of diphenylamine solution). Perform the procedure in a dark place, and the rate of the titration is about 25 drops per 10 seconds. Titrate until a blue-purple color of the solution persists for 10 seconds. Perform a blank test in the same manner, and make any necessary correction.

1 mL of 0.01 N ceric ammonium sulfate = 2.154 mg of $C_{29}H_{50}O_2$

Vitamin K1
Phylloquinone
Phytonadione



Chemical Formula: $C_{31}H_{46}O_2$

Molecular Weight: 450.71

Synonyms: Phytonadione

CAS No.: 84-80-0

Compositional Specifications of Phylloquinone

Content Phylloquinone should contain within a range of 97.0~102.0% of phylloquinone ($C_{31}H_{46}O_2$).

Description Phylloquinone is transparent sticky yellow ~ orange yellow liquid.

Identification (1) UV absorption spectrum of a solution of Phylloquinone in iso-octane (1→100,000) should be identical as the same absorption spectrum of a phylloquinone standard.

(2) Dissolve 50 mg of Phylloquinone in 10 mL of alcohol and add 1 mL of 10% potassium hydroxide alcoholic solution. It turns blue. When it is set-aside, the color changes from blue to violet and to brown.

(3) Dissolve 50 mg of Phylloquinone in 10 mL mixture of methyl alcohol-alcohol (1:1)(Test Solution). 0.75 g of sodium hydrosulfite is dissolved in 2 mL of warm water When this solution is added to the Test Solution and shaken vigorously, the yellow color disappears.

Purity (1) Refractive Index : Refractive Index n_D^{20} of Phylloquinone should be within a range of 1.525~1.529.

(2) Clarity and Color of Solution : When 1.0 g of Phylloquinone is dissolved in 10 mL of iso-octane, the solution should be clear and yellow.

(3) Absorption Ratio : Absorption (A_1 , A_2 , and A_3) of iso-octane solution of Phylloquinone (1→100,000) is measured at 248.5 nm, 253.5 nm, and 269.5 nm, respectively. A_2/A_1 and A_2/A_3 should be within a range of 0.69 ~ 0.73 and 0.74 ~ 0.78, respectively. Absorption (A_4 and A_5) of iso-octane solution of Phylloquinone(1→100,000) is measured at 284.5 nm and 326.0 nm, respectively. A_4/A_5 should be within a range of 0.28 ~ 0.34.

(4) Lead : When 5.0 g of Phylloquinone is tested by Atomic Absorption Spectrophotometry or Inductively Coupled Plasma Emission Spectroscopy, its content should not be more than 2.0 ppm.

(5) Menadione : To 20 mg of Phylloquinone, add 0.5 mL of mixture of alcohol and water (1:1) and add 1 drop of 1-phenyl-3-methyl-5-pyrazolon in alcohol and 1 drop of ammonia water, which is set-aside for 2 hours. The solution should not turn bluish violet.

Assay 0.1 g of Phylloquinone is precisely weighed and transferred into a 100 mL volumetric flask and add iso-octane to make 100 mL. Take 10 mL of this solution, add iso-octane to make 100 mL. Take 10 mL of the resulting solution, add iso-octane to make 100 mL (Test Solution). Separately, a Standard Solution is prepared using approximately 0.1 g (precisely weighed) of phylloquinone standard by following the same procedure as above. Maximum absorption near 248.5 nm is measured for Test Solution and Standard Solution with 1 cm path length using iso-octane as a reference. The content is calculated by the following equation.

$$\text{Content (\%)} = \frac{A_U}{A_S} \times \frac{W_S}{W_U} \times 100$$

A_U : Absorption of Test Solution

A_S : Absorption of Standard Solution

W_S : Weight of standard material (g)

W_U : Weight of sample (g)

Storage Standards of Phylloquinone

Phylloquinone should be preserved in a sealed, Light-resistant container.

Xanthan Gum

INS No.: 415

CAS No.: 11138-66-2

Definition Xanthan Gum is a high-molecular-weight polysaccharide gum produced by a pure culture fermentation of a carbohydrates with *Xanthomonas Campestris*, purified by isopropyl alcohol, dried, and milled. Xanthan Gum is a mixture of sodium, potassium, and calcium salt of glucose, mannose, and gluconates.

Compositional Specifications of Xanthan Gum

Content Xanthan Gum (on the dried basis) contains 4.2~5.0% of carbon dioxide (CO₂), which corresponds to 91.0~108.0% of xanthan gum.

Description Xanthan Gum is white to pale brown powder and has a little odor.

Identification 300 mL of water, previously heated to 80°C, is transferred into a 500 mL beaker and a stir with a mechanical stirrer. 1.5 g of Xanthan Gum and 1.5 g of locust bean gum are added and dissolved, which is then kept at 60°C or higher for 30 minutes. When it allowed to cool at room temperature for at least 2 hours, a rubbery gel is formed. When locust bean gum is not mixed, a rubbery gel does not form.

Purity (1) Arsenic : It should be no more than 4.0 ppm tested by Arsenic Limit Test.

(2) Lead : When 5.0 g of Xanthan Gum is tested by Atomic Absorption Spectrophotometry or Inductively Coupled Plasma Emission Spectroscopy, its content should not be more than 2.0 ppm.

(3) Isopropyl Alcohol : 4 g of Xanthan Gum is accurately weighed and transferred into a 300 mL round bottom flask, 200 mL of water is added, boiling chips and 1 mL of silicone resin are added and mixed well. Fractionating column is connected to this, 4 mL of internal standard solution is accurately taken and added to a 100 mL flask. With adjusting the heat so that foam does not enter the column, distill the solution at the rate of 2~3 mL per 1 minute until the milky liquid becomes about 90 mL, and water is added to make 100 mL, test solution. However, tert-butyl alcohol (1→1,000) is used as internal standard solution. Separately, 0.5 g of isopropyl alcohol is precisely weighed and water is added to make 500 mL, again 2 mL of this solution and 4 mL of internal standard solution is taken, water is added to make 100 mL, standard solution. 2 μ l of test solution and standard solution is taken respectively, and injected to gas chromatograph as the following operation condition. Then, ratio of isopropyl alcohol peak against tert-butyl alcohol peak in test solution and standard solution, QT and QS, is calculated separately, and the content of isopropyl alcohol is calculated by following formula, the content should not be more than 0.05%.

$$\text{Content of Isopropyl alcohol(\%)} = \frac{\text{Weight of isopropyl alcohol(g)}}{\text{Weight of sample(g)}} \times \frac{Q_T}{Q_S} \times \frac{2 \times 100}{500 \times 100} \times 100$$

QT : Ratio of isopropyl alcohol peak against tert-butyl alcohol peak in Test Solution

QS : Ratio of isopropyl alcohol peak against tert-butyl alcohol peak in standard solution

Operation Conditions

Column : PLOT Q or equivalent

Detector : Hydrogen Flame Ionization Detector (FID)

Temperature at injection port : 200°C

Column Temperature : 120°C

Detector temperature : 300°C

Carrier gas : Nitrogen or Helium

- (4) Viscosity : Viscosity of 1% aqueous solution of Xanthan Gum is measured by 2. Rotational Type Viscosity Measurement in Viscosity Measurement. It should be 600 cps or higher.
- (5) Nitrogen : When Xanthan Gum is tested by Kjeldahl Nitrogen Test in nitrogen determination method, the amount should not be more than 1.5%.
- (6) Total Viable Aerobic Count : When Xanthan Gum is tested by Microbe Test Methods for Total Viable Aerobic Count (Number of General Germs) in General Test Method in 「Standards and Specifications for Foods」, it should not be more than 5,000 cfu per 1 g.
- (7) E. Coli : When Xanthan Gum is tested by Microbe Test Methods for E. Coli in General Test Method 「Standards and Specifications for Foods」, it should be negative (-).
- (8) Salmonella : When Xanthan Gum is tested by Microbe Test Methods for Salmonella in General Test Method 「Standards and Specifications for Foods」, it should be negative (-).
- (9) Number of Fungi : When Xanthan Gum is tested by Microbe Test Methods for Number of Fungi in General Test Method in 「Standards and Specifications for Foods」, it should not be more than 500 per 1 g.

Loss on Drying When Xanthan Gum is dried for 2 hours and 30 minutes at 105°C, the weight loss should not be more than 15%.

Residue on Ignition When Residue on Ignition is done with accurately weighed 3 g of Xanthan Gum, the amount of residue should be between 6.5 and 16.0%.

Pyruvic Acid (1) Test Solution : 600 mg of Xanthan Gum is precisely weighed and dissolved in water to make 100 mL. 10 mL of this solution is placed in a 250 mL round bottom flask and 20 mL of 1N hydrochloric acid is added. Then record the whole weight and a reflux condenser is attached. It is then refluxed for 3 hours and cooled. The reflux condenser is removed and water is added to make up for any weight loss during refluxing. 2 mL of this solution is transferred into a 30 mL separatory funnel containing 1 mL solution of 1 g 2,4-dinitrophenylhydrazine prepared in 200 mL 2 N hydrochloric acid

with a stop cock. It is then mixed and allowed to stand at room temperature for 5 minutes. The mixture is then extracted with 5 mL of ethylacetate and aqueous phase is discarded. The hydrazone is extracted three 5 mL portions of sodium carbonate TS. The total volume of the resultant extract is brought up to 50 mL with sodium carbonate TS.

(2) Standard Solution : 45 mg of pyruvic acid is precisely weighed into 500 mL volumetric flask, diluted with water and mix. 10 mL of this solution is taken and continued as directed under sample solution.

(3) Test Method : Absorbance of Test Solution and Standard Solution are determined at 375 nm using sodium carbonate TS as a blank. Absorbance value of Test Solution should be greater than that of Standard Solution (not less than 1.5%).

Assay

Experimental apparatus is as follows.



(1) Experimental Apparatus

A : Soda Water Tower (filled with calcium hydroxide granules)

B : Mercury Valve

C : Side Arm

D : 100 mL Reaction flask with a long neck

E : Heating Device

F : Reflux Condenser

G : 400 mL connection tube which is connected to the reaction tube

H : Stopcock

I : Trap (It is filled with approximately 25 g of 20 mesh zinc or tin and connected to an absorption tower,

J).

J : Absorption Tower (It is consisted of a connection tube and a trap. There is a glass filter in-between.)

K : Erlenmeyer Flask (Connected to the bottom of the absorption tower)

L : Soda water tower

M : Three way stopcock

N : All the ground joints of capillary controller or needle valve (which controls air flow or vacuum) are 35/25.

(2) Experimental Method : Approximately 1.2 g of Xanthan Gum is precisely weighed and transferred into flask (D), where 25 mL of 0.1 N hydrochloric acid and boiling stones are added. The reaction flask is then connected (Vaseline is applied to the ground joints. Mercury in the inner tube of the mercury valve (B) is raised by approximately 5 cm and check for air leakage. The stop cock (M) is closed to hold the pressure. If the mercury does not drop in 1 ~ 2 minutes, there is no leak.). It is then heated for 2 minutes and cooled for 15 minutes in a flowing air (CO₂-free) at a flow rate of 3,000~6,000 mL per hour. 23 mL of hydrochloric acid is added through the connection tube (G) and the absorption tower (J) is disconnected. 25 mL of 0.25 N sodium hydroxide solution and 5 drops of butyl alcohol are added to the absorption tower, which is then re-connected. Then air (CO₂-free) flow at a rate of 2,000 mL per hour. Hydrochloric acid in the connection tube (G) is transferred to the flask (D), which is then heated for 2 hours and cooled. Using compressed air, sodium hydroxide solution in the absorption tower is transferred into the flask (K). The absorption tower is washed three 15 mL portion of water using compressed air. The flask is separated from the apparatus. 10 mL of 10% barium chloride solution is added to the flask, which is then plugged and mixed for approximately 2 minutes. It is then titrated with 0.1 N hydrochloric acid using phenolphthalein TS as an indicator. Separately, a blank test is carried out by the same procedure.

0.25 N sodium hydroxide solution 1 mL = 5.5 mg CO₂

$$\text{CO}_2(\%) = \frac{5.5 \times (B-S)}{2.5 \times \text{Weight of the sample(mg)}} \times 100$$

B : Consumed amount of 0.1 N hydrochloric acid for blank test (mL)

S : Consumed amount of 0.1 N hydrochloric acid for the test (mL)

Xylanase

Definition Xylanase is an enzyme obtained from cultures of *Thermomyces lanuginosus* and *Aspergillus oryzae* inserted the genes of xylanase. Dilutant or stabilizer can be added for the purpose of activity adjustment and quality preservation.

Compositional Specifications of Xylanase

Description Xylanase is white ~ dark brown power, granular, pasty substances or colorless ~ dark brown liquid.

Identification When Xylanase is proceeded as directed under Activity Test, it should have the activity as Xylanase.

Purity (1) Arsenic : It should be no more than 4.0 ppm tested by Arsenic Limit Test.

(2) Lead : When 5.0 g of Xylanase is tested by Atomic Absorption Spectrophotometry or Inductively Coupled Plasma Emission Spectroscopy, its content should not be more than 5.0 ppm

(3) Coliform Group : Xylanase proceed as directed under Microbe Test Methods in Coliform Group in General Test Methods in 「Standards and Specifications for Foods」. It should contain not more than 30 colonies per 1 g of this product.

(4) Salmonella : When Xylanase is tested by Microbe Test Methods for Salmonella in General Test Method 「Standards and Specifications for Foods」, it should be negative (-).

(5) E. Coli : When 25 g of Xylanase is tested by Microbe Test Methods for E. Coli in General Test Method 「Standards and Specifications for Foods」, it should be negative (-).

Activity Test (activity)

Analysis principle : Azo-wheat arabinoxylan substrate(colored with remazol) by treating with Xylanase for 15 minutes at pH 6.0, temperature 50°C is precipitated with ethanol and activity test is based on colorimetry of the blue color of decomposition supernatant of remazol colored substrate which is not precipitated.

Preparation of Test Solution : When Xylanase is weighted, use water or phosphate buffer solution so that 1 mL of the final diluent solution contains 0.4~1.4 Xylanase unit.

Procedure : Take precisely 0.1 mL of test solution into tube, keep it at 50±0.5°C for 10 minutes. Then add precisely 0.9 mL of substrate solution and immediately shake it to mix. Keep this solution at 50±0.5°C precisely for 30 minutes. Then add 5 mL of stop solution and immediately shake it to mix. Keep this solution for 30 minutes and centrifuge it by 4,000rpm for 15 minutes. Measure absorbance of supernatant at wavelength 585nm within 20 minutes.

Preparation of standard curve : Weigh precisely Xylanase(Novozyme co. or its equivalent) which contains 4000 Xylanase unit. After dissolving it in 0.1M phosphate buffer solution(pH 6.0), make to volume to 200 mL. Take precisely 2 mL, 3 mL, 4 mL, 5 mL, 6 mL and 7 mL of this solution. Then add 0.1M phosphate buffer solution(pH 6.0) to each solution to make to 100 mL. This solution is used as each standard solution. 1 mL of each solution contains Xylanase of 0.4, 0.6, 0.8, 1.2 and 1.4 unit. Take precisely 0.1 mL

of standard solution into each tube, keep it at $50 \pm 0.5^\circ\text{C}$ for 10 minutes. Then add precisely 0.9 mL of substrate solution and immediately shake it to mix. Keep this solution at $50 \pm 0.5^\circ\text{C}$ precisely for 30 minutes. Then add 5 mL of stop solution and immediately shake it to mix. Keep this solution for 30 minutes and centrifuge it by 4,000rpm for 15 minutes. Measure absorbance of supernatant at wavelength 585nm within 20 minutes. The factor of enzyme(unit/mL) is plotted along the X axis and the absorbance is plotted along the Y axis. Prepare standard curve of enzyme activity.

Activity of an enzyme is calculated by the following equation.

$$\text{Xylanase (units/g)} = \frac{C}{W}$$

C : Activity of test solution is obtained from standard curve

W : Weight of sample in 1 mL of test solution(g)

Reagent

Substrate solution : Weigh precisely 0.5 g of azo-wheat arabinoxylan(Megazyme co. or its equivalent) and dissolve it in 0.1M phosphate buffer solution(pH 6.0). Add 0.1M phosphate buffer solution(pH 6.0) to make to 100mL.

Stop solution : Add 99.9% ethanol to 6.65 mL of 2N hydrochloric acid to make the total volume to 1,000 mL.

Phosphate buffer solution(pH 6.0) : Weigh 60.5 g of sodium phosphate, monobasic($\text{Na}_2\text{H}_2\text{PO}_4 \cdot \text{H}_2\text{O}$) and 10.945 g of sodium phosphate,dibasic($\text{Na}_2\text{HPO}_4 \cdot \text{H}_2\text{O}$) and dissolve them in 400 mL of water. Add 2 mL of 4N sodium hydroxide solution and then add water to make to 500 mL. After taking 200 mL of this solution, add 1,600 mL of water to mix. Adjust pH to 6.0 with 4N sodium hydroxide solution or 2N hydrochloric acid and add water to make to 2,000 mL.

Storage Standard of Xylanase

Xylanase should be stored in a hermetic container in a cold dark place.

Xylitol

1,2,3,4,5 - Pentahydroxypentane

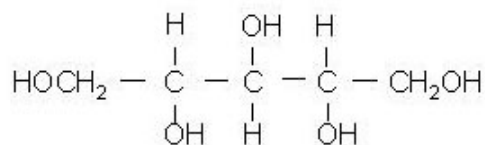

Chemical Formula: $\text{C}_5\text{H}_{12}\text{O}_5$

Molecular Weight: 152.15

INS No.: 967

Synonyms: 1,2,3,4,5-Pentahydroxypentane

CAS No.: 87-99-0

Compositional Specifications of Xylitol

Content Xylitol, when calculated on the dried basis, should contain within a range of 98.5~101.0% xylitol ($\text{C}_5\text{H}_{12}\text{O}_5$).

Description Xylitol is white crystal or crystalline powder.

Identification (1) When Xylitol proceed as directed under (1) potassium bromide disk method in Infrared Spectrophotometry, the maximum absorption should appear at the same wavelength as a xylitol standard. If there is any difference, both the sample and the standard are dissolved in an appropriate solvent. After solvent is dried, the same procedure is repeated with the solid material.

(2) 5 g of Xylitol is dissolved in 10 mL mixture of hydrochloric acid : formalin (1:1). The resulting solution is reacted for 2 hours at 50°C. Then 25 mL of ethyl alcohol is added. The resulting precipitates are filtered. These are recrystallized twice with ethyl alcohol. After drying for 2 hours at 105°C, melting point is measured. It should be within a range of 195~201°C.

Purity (1) Arsenic : It should be no more than 4.0 ppm tested by Arsenic Limit Test.

(2) Lead : When 5.0 g of Xylitol is tested by Atomic Absorption Spectrophotometry or Inductively Coupled Plasma Emission Spectroscopy, its content should not be more than 1.0 ppm.

(3) Nickel : When 5.0 g of Xylitol is tested by Atomic Absorption Spectrophotometry or Inductively Coupled Plasma Emission Spectroscopy, its content should not be more than 2.0 ppm.

(4) Other Polyvalence Alcohol : L-arabinitol, galactitol, and mannitol, and sorbitol are quantitatively analyzed following the same procedure as in xylitol. The content of the total polyvalence alcohols is calculated using the following equation and should not be more than 2%.

$$\text{Content}(\%) = 100 \times \frac{W_S \times R_U}{\quad}$$

$$W_u \times R_s$$

Ws : Weight of all polyvalence alcohol standards (mg)

Wu : Weight of sample (mg) (as dehydrated form)

Ru : Peak area ratio of polyvalence alcohol derivatives vs. erythritol derivatives in test solution.

Rs : Peak area ratio of polyvalence alcohol derivatives vs. erythritol derivatives in standard solution.

(5) Reduced Sugars : Approximately 500 mg of Xylitol is precisely weighed into a 10 mL Erlenmeyer flask with 2 mL of water. Use this solution as the test Solution. Separately, 2 mL of glucose solution (0.5 mg/mL) is added to another Erlenmeyer flask. 1 mL each of Fehling solution A and B is added to each Erlenmeyer flask, respectively. Both solution are boiled and then cooled. Test Solution should be less turbid than glucose solution, also should show reddish brown precipitates (Not more than 0.2%).

Water Content Water content of Xylitol is determined by water determination (Karl-Fisher Titration) and should not be more than 0.5%.

Residue on Ignition When thermogravimetric analysis is done with precisely weighed 10 g of Xylitol, the amount of residue should not be more than 0.1%.

Assay 5 g of Xylitol, precisely weighed, dissolve in water to make 100 mL (Test A Solution). Separately, 4.9 g of xylitol standard and 25 mg each of L-arabinitol, galactitol, mannitol and sorbitol, accurately weighed, transfer into a 100 mL volumetric flask, and add water to make 100 mL. Respectively (Standard A Solution). 1 mL each of Test A Solution and Standard A Solution transfer into a round bottom flask, respectively. 1 mL of internal standard solution (500 mg of erythritol is dissolved in 25 mL of water) added to each flask. Each is then evaporated to dryness using a vacuum evaporator at 60°C in a water bath. 1 mL of pyridine and 1 mL of anhydrous acetic acid are added to each flask, where a reflux condenser is attached. Both are completely acetylated by boiling. Use this solution as the test solution and standard solution. 1 µl of each Test Solution and Standard Solution is injected into gas chromatography. The content of xylitol (%) is calculated from the following equation.

$$\text{Content of xylitol(\%)} = 100 \times \frac{W_s \times R_u}{W_u \times R_s}$$

Ws : Weight of xylitol standard (mg)

Wu : Weight of sample (mg) (as dehydrated form)

Ru : Peak area ratio of xylitol derivatives vs. erythritol derivatives in test solution.

Rs : Peak area ratio of xylitol derivatives vs. erythritol derivatives in standard solution.

Operation Conditions

-Column : A stainless tube with inner diameter of 2 mm and length of 2 m

-Column Filler : Chromosorb W HP coated with 3% OV 225

-Detector : (Hydrogen) Flame Ionization Detector (FID)

-Temperature at injection hole : 250°C

- Column Temperature : 200°C
- Detector Temperature : 250°C
- Carrier gas and flow rate : Nitrogen, 30 mL per minute
- Retention time : Retention time for internal standard (erythritol) is 3.3 minutes. Relative retention time (1 minute for erythritol) for each component is approximately 2.77 for L-arabinitol, 3.9 for xylitol, 6.96 for galactitol, 7.63 for mannitol, and 8.43 for sorbitol.

D-Xylose



Chemical Formula: $C_5H_{10}O_5$

Molecular Weight: 150.13

CAS No.: 58-86-6

Definition D-Xylose is obtained from hydrolysis with hot acidic aqueous solution or enzyme and separation of wood, cotton (*Gossypium arboreum* LINNE) of malvaceae, rice (*Oryza sativa* LINNE) of gramineae, sugar cane (*Saccharum officinarum* LINNE) of gramineae, corn (*Zea Mays* LINNE) of gramineae or stems, fruits, or skins of other same genus. Its major component is D-xylose.

Compositional Specifications of D-Xylose

Content After drying, D-Xylose contains 98.0 ~ 101.0% D-xylose ($C_5H_{10}O_5$).

Description D-Xylose is colorless ~ white crystallite or white crystalline powder. It has odorless and sweet taste.

Identification (1) When 2~3 drops of aqueous solution (1→20) of D-Xylose are added to 5 mL of hot Fehling solution, red precipitate is formed.

(2) 1 g of xylose is dissolved in 25 mL of water (freshly boiled and cooled). This solution is dextrorotatory.

(3) 1 g of D-Xylose is dissolved in 3 mL of water by heating, where 3 mL mixture of 4 mL alcoholic solution of diphenyl amine (1→40) and 10 mL of diluted hydrochloric acid. When the solution is heated for 5 minutes in a water bath, it showed yellow ~ pale orange color.

(4) 0.5 g of D-Xylose is dissolved in 20 mL of water, where 30 mL of phenylhydrazine hydrochloride-sodium acetate solution and 10 mL of diluted acetic acid are added. When the solution is heated in a water bath, precipitate is formed, which are recrystallized in water. The melting point of the precipitate is 160~163°C.

Purity (1) Clarity of Solution : When 4 g of D-Xylose is dissolved in 200 mL of water, it is colorless and almost clear.

(2) Free acid : 1 g of D-Xylose is dissolved in 10 mL of water (freshly boiled and cooled). When 1 drop of phenolphthalein solution and 1 drop of 0.2 N sodium hydroxide solution are added to this solution, it should turn red.

(3) Sulfates : 1 g of D-Xylose is dissolved in 30 mL of water. When this Solution is tested for sulfates, the content should not be more than the amount that corresponds to 0.1 mL of 0.01 N sulfuric acid.

(4) Arsenic : It should be no more than 1.0 ppm tested by Arsenic Limit Test.

(5) Lead : When 5.0 g of D-Xylose is tested by Atomic Absorption Spectrophotometry or Inductively Coupled Plasma Emission Spectroscopy, its content should not be more than 2.0 ppm.

(6) Other Saccharides : 0.5 g of D-Xylose is dissolved in water to make 1,000 mL. 0.1 mL of D-Xylose is tested by Method 1 in Filter Paper Chromatography. When the top of developing solution reaches 15cm from the Test Solution spot, stop. The position of the solution is marked. After the solvent is blow dried, it is developed with the same solvent until the front reaches the same point. This operation is repeated one more time. Colorizing solution is sprayed on to the filter paper, which is dried for 5 minutes at 100~125°C. There should be only one red spot under natural light. Reference solution is not used.

- Developing Solution : a mixture of n-butyl alcohol, pyridine, and water (6:4:3)
- Colorizing Solution : 0.93 g of aniline and 1.66g of anhydrous phthalic acid are dissolved in 100 mL of n-butyl alcohol (saturated with water).
- Filter Paper : No.2 filter paper for chromatography is used.

Loss on Drying When 3 g of D-Xylose is dried for 3 hours at 105°C, the weight loss should not be more than 1%.

Residue on Ignition When Residue on Ignition is done with precisely weighed 5 g of D-Xylose, the amount of residue should not be more than 0.05%.

Assay Approximately 1 g of dried D-Xylose is precisely weighed and dissolved in water to make 500 mL. 10 mL of this solution is added into an iodine bottle, where precisely 50 mL of sodium meta periodate solution (1→400) is added and 1 mL of sulfuric acid is added. It is then heated for 15 minutes in a water bath. After cooling, 2.5 g of potassium iodide is added and well mixed by shaking. After allowing to stand for 15 minutes in a cold dark place, it is titrated with 0.1 N sodium thiosulfate solution (indicator : starch solution). Separately, a blank test is carried out.

0.1 N sodium thiosulfate solution 1 mL = 1.877 mg $C_5H_{10}O_5$

Yeast

Definition Liquid yeast is obtained by separating and washing cultures food-grade yeasts belonging to the *Saccharomyces sp* in the edible carbohydrate medium. Raw yeast is obtained by dehydrating and forming. Dry yeast(active) or sterilized dry yeast(inactive) is obtained by removing water from raw yeast. Small amount of emulsifier can be added.

Compositional Specifications of Yeast

A. Dry Yeast

Description Dry Yeast is yellow ~ brown granule, powder, or solid with a characteristic scent.

Purity (1) Activation(In the case, this applies to active dry yeast only) : When 5 g of Dry Yeast is added to 50 mL of 1 % sugar solution and heated to 35~40°C, gas should be generated within 2 hours and 30 minutes.

(2) Arsenic : It should be no more than 5.0 ppm tested by Arsenic Limit Test.

(3) Lead : When 5.0 g of Dry Yeast is tested by Atomic Absorption Spectrophotometry or Inductively Coupled Plasma Emission Spectroscopy, its content should not be more than 1.0 ppm.

(4) Total Viable Aerobic Count(In the case, this applies to inactive dry yeast only) : When Guar Gum is tested by Microbe Test Methods for Total Viable Aerobic Count (Number of General Germs) in General Test Method in 「Standards and Specifications for Foods」, it should not be more than 7,500 per 1 g

(5) Coliform Group(In the case, this applies to inactive dry yeast only) : When yeast proceed as directed under Microbe Test Methods for Coliform Group in General Test Methods in 「Standards and Specifications for Foods」, it should contain not more than 10 colonies per 1 g of this product.

(6) Salmonella(In the case, this applies to inactive dry yeast only) : When Locust Bean Gum is tested by Microbe Test Methods for Salmonella in General Test Method 「Standards and Specifications for Foods」, it should be negative (-).

B. Raw Yeast

Description Raw Yeast is milky white ~ yellowish brown solid with a characteristic scent.

Purity (1) Activation : When 5 g of Raw Yeast is added to 50 mL of 10% sugar solution and heated to 30~35°C, gas should be generated within 1 hour.

(2) Arsenic : It should be no more than 3.0 ppm tested by Arsenic Limit Test.

(3) Lead : When 5.0 g of Raw Yeast is tested by Atomic Absorption Spectrophotometry or Inductively Coupled Plasma Emission Spectroscopy, its content should not be more than 1.0 ppm.

C. Liquid Yeast

Description Liquid Yeast is white ~ yellowish brown liquid with a characteristic scent.

Purity (1) Activation : When 5 g of Liquid Yeast is added to 50 mL of 10% sugar solution and heated to 30~35°C, gas should be generated within 1 hour.

(2) Arsenic : It should be no more than 1.5 ppm tested by Arsenic Limit Test.

(3) Lead : When 5.0 g of Liquid Yeast is tested by Atomic Absorption Spectrophotometry or Inductively Coupled Plasma Emission Spectroscopy, its content should not be more than 1.0 ppm.

Storage Standards of Yeast

Dry yeast should be stored in light-resistant and shielded container.

Yeast Extract

Definition Yeast Extract consists of yeast cell components such as amino acids, peptides, carbohydrates, and water soluble salts. It is generated from hydrolysis of polypeptide bonds by yeast that is present in edible yeast, or added edible yeast. Salts can be added during manufacturing process

Compositional Specifications of Yeast Extract

Content When Yeast Extract is Yeast Extract, it should contain not less than 42% of protein.

Description Yeast Extract is liquid, powder, granule, or paste.

Purity Place liquid or paste sample in a container, that is previously weighted. Evaporate the sample in the water bath to dry. For powder and granule, it is dried at 105°C until the weight becomes constant. Following each content specification is based on a dried form.

- (1) Lead : When 5.0 g of Yeast Extract is tested by Atomic Absorption Spectrophotometry or Inductively Coupled Plasma Emission Spectroscopy, its content should not be more than 2.0 ppm.
- (2) Sodium : Approximately 1.5 g (converted to a dried form) is precisely weighted into a porcelain crucible and reduced to ash for 2~4 hours at 246~260°C. Dissolve the ash with 5 mL of 20% hydrochloric acid. If the residue is needed to completely dissolve, heat the solution and filter through an acid washed filter paper into a 500 mL flask. Filter paper is washed with warm water to the flask. The volume of the filtrate is brought up to 500 mL with water. 1 mL of this solution is diluted to 100 mL with water (Test Solution). Separately, 0.5 mL of undiluted sodium standard solution is diluted to 100 mL with water (Sodium Standard Solution). Sodium Standard Solution and Test Solution is analyzed with atomic absorption spectrophotometer and the content of sodium in the sample is obtained not more than 20.0%.
- (3) Potassium : Approximately 1 g (converted to a dried form) is precisely weighted into a porcelain crucible and reduced to ash for 2~4 hours at 246~260°C. Dissolve the ash with 5 mL of 20% hydrochloric acid. If the residue is needed to completely dissolve, heat the solution and filter paper into a 500 mL flask. Filter paper is washed with warm water to the flask. The volume of the filtrate is brought up to 500 mL with water. 0.8 mL of this solution is diluted to 100 mL with water (Test Solution). Potassium Standard Solution and Test Solution is analyzed with atomic absorption spectrophotometer and the content of potassium in the sample is obtained not more than 13.0%.
- Potassium Standard Solution : Potassium chloride is dried for 2 hours at 130°C. 9.534 g of dried potassium chloride is precisely weighted and dissolved in water (total volume = 1,000 mL). 0.4 mL of this solution is further diluted to 1,000mL (Standard Solution). 1 mL of this solution contains 2 µg of K.
- (4) Mercury : When Yeast extract is tested according to Mercury Test, its content should not be more than 3.0 ppm.
- (5) Insoluble substances : Approximately 5 g (converted into a dried form) is precisely weighted into a 250 mL flask with a stopper, where 75 mL of water is added. It is covered with a watch glass and

gently boiled for 2 minutes. The content is filtered through a porcelain type glass filter (previously weighted), which is then dried for 1 hour at 105°C. It is cooled in a desiccator and weighted. The content of insoluble substances should not be more than 2%.

(6) Ratio of Nitrogen in α -Amino Acid over Total Nitrogen : 7~25 g (converted into a dried form without sodium) is precisely weighted into a 500 mL volumetric flask using 50 mL of warm water (repeated several times). The total volume is brought up to 500 mL with water (Test Solution). 20 mL of Test Solution is neutralized with 0.2 N barium hydroxide solution or 0.2 N sodium hydroxide solution (indicator : phenolphthalein TS). Add 10 mL of freshly prepared phenolphthalein : formalin solution to this solution, which is titrated with 0.2 N barium hydroxide solution until it turns clear red. A small excess amount of 0.2 N barium hydroxide solution is precisely added to the resulting solution, which is back titrated with 0.2 N hydrochloric acid. Separately, a blank test is carried out by following the same procedure with 20 mL of water. The content of α -amino nitrogen is calculated by the following equation. The ratio (AN/TN) of α -amino nitrogen (AN) over total nitrogen (TN) should be 15 ~ 55%.

1 mL of 0.2 N barium hydroxide solution = 2.8 mg of α -amino nitrogen

• Phenolphthalein Formalin Solution : 50 mL of 40% formalin containing 1 mL of 0.05% phenolphthalein TS in 50% alcohol (neutralized to pH 7.0 with 0.2 N barium hydroxide solution or 0.2 N sodium hydroxide solution).

(7) Glutamic Acid : 5 mg (converted to a dried form) of Yeast Extract is precisely weighted and added with 0.2 N sodium citrate buffer solution (pH 2.2, total volume 5 mL) (Test Solution). If there is any insoluble residue, it is filtered or centrifuged and the supernatant is used. 2 mL each of Test Solution and glutamic acid standard solution is analyzed by ion exchange amino acid analyzer. From the obtained chromatogram, the concentration of glutamic acid (C_A , mg/mL) in Test Solution is obtained. The content of glutamic acid in sample is obtained by the following equation and it should not be more than 12.0%. The content of glutamic acid in total amino acid should not be more than 28.0%.

$$\text{Content of glutamic acid(\%)} = \frac{C_A \times 5 \times 100}{\text{weight of the sample(mg)}}$$

$$C_A \text{ (mg/mL)} = \frac{A_A \times C_s}{A_s}$$

A_A : Peak area of glutamic acid in Test Solution

A_s : Peak area of glutamic acid in glutamic acid Standard Solution

C_s : Concentration of glutamic acid Standard Solution (mg/mL)

$$\frac{\text{Glutamic acid content in total amino acid (\%)}}{\text{content of glutamic acid(\%)}} = \frac{\text{content of glutamic acid(\%)}}{6.25N_T} \times 100$$

N_T : Total nitrogen content (%)

-Ion Exchange Amino Acid Analyzer : A sulfonated polystyrene column is attached. sample is eluted by reacting with ninhydrine solution. Absorptions at 440 nm and 570 nm are automatically measured by spectrophotometer.

- Glutamic Acid standard solution : 1,250 ± 2 mg of glutamic acid is precisely weighted into a 500 mL volumetric flask, and made 250 mL with water. dissolve undissolved amino acid by adding 5 mL of hydrochloric acid. The total volume is brought up to 500 mL with water. Exactly 1 mL of this solution is mixed with 4 mL of sodium citrate buffer solution (pH 2.2) (total volume = 5 mL). 2 mL of this solution contains 1.0 mg of glutamic acid.
- 0.2 N Sodium Citrate Buffer Solution (pH 2.2) : Dissolve weighted 10.52 g of sodium citrate in 150 mL of water. pH of this solution is adjusted to pH 2.2, which is then diluted to 200 mL with water.
- Ninhydrine standard solution : 18 g of ninhydrin and 0.7 g of hydrindantin is precisely weighed and dissolved in 675 mL of dimethyl sulfoxide. This solution is added to 225 mL of acetic lithium standard solution (pH 5.2).

(8) Total viable aerobic count : Yeast Extract (converted to a dried form) is tested by Total viable aerobic count in Microbiological Methods in General Testing Methods in 「Standards and Specifications for Foods」. It should not be more than 50,000 per 1 g.

(9) Fungi : Yeast Extract (converted to a dried form) is tested by Fungi in Microbiological Methods in General Testing Methods in 「Standards and Specifications for Foods」. It should not be more than 50 per 1 g.

(10) Coliform Group : Yeast Extract (converted to a dried form) is tested by Microbiological Methods for Coliform Group in General Testing Methods in 「Standards and Specifications for Foods」. It should not be more than 10 per 1 g.

(11) Salmonella : Yeast Extract (converted to a dried form) is tested by Microbiological Methods for Salmonella in General Testing Methods in 「Standards and Specifications for Foods」. It should be negative (-).

Assay Approximately 0.3 g (converted to a dried form, nitrogen excluded) of Yeast Extract is analyzed by the procedure in Kjeldahl Method in Nitrogen Determination Method.

0.1 N sulfuric acid 1 mL = 1.401 mg N

Yucca Extract

Definition Yucca Extract is obtained by extracting roots of yucca (*Yucca brevifolia* Engelm, *Yucca schidigera*) of agavaceae with water. Dilutant or other food additives can be added for the purpose of quality preservation.

Compositional Specifications of Yucca Extract

Description Yucca Extract is a dark brown liquid with a characteristic scent.

Identification 1 g of Yucca Extract is dissolved in water (total volume = 1,000 mL). This solution has a maximum absorption band at 250 ~ 300 nm.

Purity (1) Acidity : pH of Yucca Extract should be 3.8~4.0.

(2) Coliform Group : When Yucca Extract proceed as directed under Microbiological Methods for Coliform Group in General Testing Methods in 「Standards and Specifications for Foods」, it should be negative (-).

(3) Formability : 1.9 L of water is added to a 3.8ℓ glass bottle (16.3cm diameter), where 6 drops of 85% phosphoric acid are added. Add 60 mL of aqueous solution of Yucca Extract (1.1→1,000), the bottle is shaken vigorously 100 times. The height of foam layer should be maintained at 1.2 cm or more for 30 seconds.

(4) Arsenic : It should be no more than 2.0 ppm tested by Arsenic Limit Test.

(5) Lead : When 5.0 g of Yucca Extract is tested by Atomic Absorption Spectrophotometry or Inductively Coupled Plasma Emission Spectroscopy, its content should not be more than 2.0 ppm.

Ash 5 g of Yucca Extract is precisely weighted and tested by Ash and Acid-Insoluble Ash Limit, the amount of ash should not be more than 10%.

Residue on Ignition When Yucca Extract is tested by Residue on Ignition, its content should not be more than 5.0%.

Zinc Gluconate



Chemical Formula: $\text{C}_{12}\text{H}_{22}\text{O}_{14}\text{Zn}\cdot n\text{H}_2\text{O}$ ($n = 0 \sim 3$)

Molecular Weight: 455.69

CAS No.: 4468-02-4

Compositional Specifications of Zinc Gluconate

Content If Zinc Gluconate, when calculated on the dried basis(anhydrous), it should contain 97.0 ~ 102.0% of zinc gluconate ($\text{C}_{12}\text{H}_{22}\text{O}_{14}\text{Zn}$).

Description Zinc Gluconate occurs as white crystalline powder or granules.

Identification (1) Zinc Gluconate solution (1→10) responds to the test for Zinc Salt in Identification.

(2) Proceed as directed under Identification (2) for 「Sodium Gluconate」.

Purity (1) Cadmium : When 5.0 g of Zinc Gluconate is tested by Atomic Absorption Spectrophotometry or Inductively Coupled Plasma Emission Spectroscopy, its content should not be more than 2.0 ppm.

(2) Chloride : When 0.3 g of Zinc Gluconate is tested by Chloride Limit Test, the content should not be more than the amount that corresponds to 0.42 mL of 0.01 N hydrochloric acid.

(3) Sulfate : When 0.49 g of Zinc Gluconate is tested by Sulfate Limit Test, the content should not be more than the amount that corresponds to 0.5 mL of 0.01 N sulfuric acid.

(4) Lead : When 5.0 g of Manganese Gluconate is tested by Atomic Absorption Spectrophotometry or Inductively Coupled Plasma Emission Spectroscopy, its content should not be more than 2.0 ppm.

(5) Arsenic : It should be no more than 4.0 ppm tested by Arsenic Limit Test.

(6) Reducing Matter : Approximately 1 g of Zinc Gluconate is weighed and transferred into a 250 mL Erlenmeyer flask. 10 mL of water is added to dissolve the solid and 25 mL of alkaline copper citrate solution. A small beaker is placed on top of the flask, which is heated for precisely 5 minutes. It is then rapidly cooled to room temperature. To this solution, 25 mL of diluted acetic acid (1→10), 10 mL of 0.1 N iodine solution, 10 mL of dilute hydrochloric acid, and 3 mL of starch solution are added. The resulting solution is titrated with 0.1 N sodium thiosulfate solution until the blue color disappears. The content of reduced materials should not be more than 1.0%.

$$\text{Content of Reducing Matter(as glucose)}(\%) = \frac{(V_1N_1 - V_2N_2) \times 27}{\text{weight of the sample}(\text{mg})} \times 100$$

V_1 : Consumed amount of 0.1 N iodine solution (mL)

N_1 : Normality of 0.1 N iodine solution

V_2 : Consumed amount of 0.1 N sodium thiosulfate solution (mL)

N_2 : Normality of 0.1 N sodium thiosulfate solution

27 : Experimental corresponding amount for D-glucose

Water Content Water content of Zinc Gluconate as determined by water content determination method (Karl-Fischer Method) should not be more than 11.6%.

Assay Accurately weigh about 0.7 g of Zinc Gluconate, add 100 mL of water, dissolve while warming if necessary, add 5 mL of ammonia-ammonium chloride solution, and 0.1 mL of Eriochrom black solution are added to the solution, which is titrated with 0.05 M EDTA solution until the color becomes blue.

1 mL of 0.05 M EDTA = 22.784 mg of $C_{12}H_{22}O_{14}Zn$

Zinc Oxide

Chemical Formula: ZnO

Molecular Weight: 81.38

CAS No.: 1314-13-2

Compositional Specifications of Zinc Oxide

Content After ignition, Zinc Oxide should contain not less than 99.0% of zinc oxide (ZnO).

Description Zinc Oxide is fine, white, and scentless powder.

Identification (1) When Zinc Oxide is strongly heated, it becomes to yellow. After cooling, the color disappears.

(2) The solution, which Zinc Oxide dissolve in 3 N hydrochloric acid, responds to the test for Zinc Salt in Identification.

Purity (1) Alkalinity : 2 g of Zinc Oxide is dispersed in 20 mL of water and boiled for 1 minute, which is then filtered. When 0.1 mL of phenolphthalein indicator solution is added, this solution should not become to red.

(2) Lead : Zinc Oxide is tested by purity (2) for 「Sodium Metaphosphate」(not more than 10 ppm).

(3) Cadmium : Zinc Oxide is tested by purity (3) for 「Sodium Metaphosphate」(not more than 3.0 ppm).

(4) Substances that do not precipitate by sulfate : Dissolve about 2 g of Zinc Oxide, accurately weighed, in 20 mL diluted acetic acid (1→4) and add water to make 200 mL. Zinc is completely precipitated by adding ammonium sulfide standard solution and the precipitates are filtered. First portion of the filtered solution is discarded. 100 mL from the later portion is then placed on a platinum dish, which was previously heat treated until the weight doesn't change. A few drops of sulfuric acid are added to this solution, which is then evaporated to dryness. It is then heat treated carefully at $800 \pm 25^\circ\text{C}$ until sublimes. After the weight becomes constant, the amount of residue not more than 5 mg.

Loss on Ignition 2 g of Zinc Oxide is precisely weighed and heat treated at $800 \pm 25^\circ\text{C}$ until the weight becomes constant, the weight loss should not be more than 1%.

Assay Dissolve about 1.5 g of Zinc Oxide, previously weighed and heat treated, in 50 mL of 1 N sulfuric acid that contains 2.5 g of ammonium chloride (heat slowly if necessary). The solution is then titrated with 1 N sodium hydroxide solution (indicator : methyl orange solution).

1 mL of 1 N Sulfuric Acid = 40.69 mg ZnO

Zinc Sulfate

Chemical Formula: $\text{ZnSO}_4 \cdot 7\text{H}_2\text{O}$

Molecular Weight: 287.54

CAS No.: 7446-20-0

Compositional Specifications of Zinc Sulfate

Content Zinc Sulfate, when calculated on the dried basis(anhydrous), should contain not less than 98.0 % of zinc sulfate(ZnSO_4).

Description Zinc Sulfate occurs as colorless needles, granules, or white crystalline powder. It is odorless.

Identification Zinc Sulfate solution (1→20) responds to the tests for Zinc Salt and Sulfate in Identification.

Purity (1) Free acid : When add 1 drop of methyl orange solution to Zinc Sulfate solution (1→20), the color of the solution should not be changed to pink

(2) Alkali Metal and Alkali-Earth Metals : Weigh 2 g of Zinc Sulfate, transfer into a 200 mL flask, dissolve in 150 mL of water, and add ammonium sulfide until the precipitate is no longer formed. Add water to make 200 mL, and filter through a dry filter paper. Discard the initial filtrate. take 100 mL of the subsequent filtrate, evaporate to dryness, ignite to constant weight, and weigh the residue. It is then heat treated until the weight becomes constant. The content should not be more than 0.5%.

(3) Arsenic : It should be no more than 4.0 ppm tested by Arsenic Limit Test.

(4) Lead : Zinc Sulfate is tested by purity (2) for 「Sodium Metaphosphate」(not more than 4.0 ppm).

(5) Cadmium : Zinc Sulfate is tested by purity (3) for 「Sodium Metaphosphate」(not more than 2.0 ppm).

(6) Mercury : When Zinc Sulfate is tested by Mercury Limit Test, its content should not be more than 5.0 ppm.

Water Content Precisely weigh 0.1 g of Zinc Sulfate. When it is tested by the direct titration method in water content determination (Karl-Fischer Method), the water content should not be more than 43.5%.

Assay Accurately weigh about 300 mg of Zinc Sulfate, add 100 mL of water, add 5 mL of ammonia-ammonium chloride buffer, and titrate with 0.05 M EDTA (indicator : 0.1 mL of Eriochrome black T solution) until the color of the solution changes to deep blue.

1 mL of 0.05 M EDTA = 8.073 mg of $\text{ZnSO}_4 \cdot 7\text{H}_2\text{O}$

Natural Flavoring Substances

Definition These materials are obtained from the following origins by processes such as extraction, distillation, **microbiological or enzymatic processes**. They are used to add or enhance aroma. There are refined oils, extracts, and Oleoresin (spice oleoresins whose specification is separately set is excluded). **However, microorganisms used for microbiological process shall be listed on [Annex 1] and [Annex 2] of 「Food Code」, and enzymes used for enzymatic process shall be food additives regulated on this 「Food Additives Code」. Moreover,** these materials include two or more simple combinations of the following flavors in a way that does not cause any chemical changes. And water, spirits(ethyl alcohol), vegetable oil can be added for preserving quality.

(1) When natural flavoring substances are prepared or processed, appropriate solvents (ethyl alcohol, hexane, isopropyl alcohol) are used individually or together, and they are obtained by extraction from each raw material. Used solvents should be removed upon specification of residual solvents.

Compositional Specifications of natural flavoring substances

Purity Residual Solvents (limited to form of oleoresin) : When natural flavoring substances is tested by Purity (5) for Paprika Extract Pigments,the content of residual solvents should be,

Isopropyl alcohol	Not more than 50ppm
Hexane	Not more than 25ppm

No.	General Name	Origin Name
1	Alfalfa	<i>Medicago sativa</i> L.
2	Almond, bitter(free from prussicacid) (Bitter almond)	<i>Prunus amygdalus</i> Batsch. <i>Prunus armeniaca</i> L., or <i>Prunus persica</i> (L.) Batsch.
3	Ambergris	<i>Physeter macrocephalus</i> L.
4	Ambrette(seed)	<i>Hibiscus moschatus</i> Moench.
5	Amyris(West Indian sandalwood)	<i>Amyris balsamifera</i> L.
6	Angelica root	<i>Angelica archangelica</i> L.
7	Angelica seed	<i>Angelica archangelica</i> L.
8	Angelica stem	<i>Angelica archangelica</i> L.
9	Angola weed	<i>Roccella fuciformis</i> Ach
10	Angostura (Cusparia bark)	<i>Galipea officinalis</i> Hancock.
11	Anise	<i>Pimpinella anisum</i> L.
12	Apricot kernel (Persic oil)	<i>Prunus armeniaca</i> L.
13	Arnica flowers	<i>Arnica montana</i> L., <i>A. fulgens</i> Pursh, <i>A. sororia</i> A. <i>fulgens</i> Pursh, <i>A. sororia</i> Greene, or <i>A. cordifolia</i> Hooker.
14	Artemisia (Wormwood)	<i>Artemisia</i> spp.
15	Artichoke leaves	<i>Cynara scolymus</i> L.
16	Asafetida	<i>Ferula</i> (<i>Ferula assa-foetida</i> L. and related spp. Of <i>Ferula</i> .)

No.	General Name	Origin Name
17	Balm(Lemon balm, Melissa)	Melissa officinalis L.
18	Balsam of Peru	Myroxylon pereirae Klotzsch.
19	Basil	Ocimum basilicum L.
20	Bay leaves	Laurus nobilis L.
21	Bay(Myrcia oil)	Pimenta racemosa (Mill.) J. W. Moore.
22	Benzoin resin	Styrax benzoin Dryander, S. paralleloneurus Pekins, S. tonkinensis(Pierre) Craib ex Hartwich, or other spp. Of the Section Anthostyrax of the genus Styrax.
23	Bergamot(Bergamot orange)	Citrus aurantium L. subsp. Beramia Wright et Arn.
24	Blackberry bark	Rubus, Section Eubatus.
25	Bois de rose	Aniba rosaeodora Ducke.
26	Boldus(Boldo) leaves	Peumus boldus Mol.
27	Boronia flowers	Boronia megastigma Nees.
28	Bryonia root	Bryonia alba L., or B. dioica Jacq
29	Buchu leaves	Barosma betulina Bartl. Et Wendl., B. crenulata(L.) Hook. Or B. serratifolia Willd.
30	Buckbean leaves	Menyanthes trifoliata L.
31	Cacao	Theobroma cacao L.
32	Cajeput	Melaleuca leucadendron L. and other Melaleuca spp.
33	Camomile(Chamomile) flowers, Hungarian	Matricaria chamomilla L.
34	Camomile(Chamomile) flowers, Roman or English	Anthemis nobilis L.
35	Camphor tree	Cinnamomum camphora (L.) Nees et Eberm

No.	General Name	Origin Name
36	Cananga	Cananga odorata Hook. F. and Thoms.
37	Capsicum	Capsicum frutescens L. and Capsicum annuum L.
38	Caraway	Carum carvi L.
39	Cardamomseed (Cardamon)	Elettaria cardamomum Maton.
40	Carrot	Daucus carota L.
41	Cascara sagrada	Rhamnus purshiana DC.
42	Cascarilla bark	Croton eluteria Benn.
43	Cassia bark, Chinese	Cinnamomum cassia Blume.
44	Cassia bark, Padang or Batavia	Cinnamomum burmanni Blume.
45	Cassia bark, Saigon	Cinnamomum loureirii Nees.
46	Cassie flowers	Acacia farnesiana(L.) Willd.
47	Castoreum	Castor fiber L. and C. canadensis Kuhl.
48	Catechu, black	Acacia catechu Willd.
49	Cedar, white(Aborvitae), leaves, and twigs	Thuja occidentalis L.
50	Celery seed	Apium graveolens L.
51	Centuary	Centaurium umbellatum Gilib
52	Cherry pits	Prunus avium L. or P. cerasus L.
53	Cherry laurel leaves	Prunus laurocerasus L.
54	Cherry, wild, bark	Prunus serotina Ehrh.
55	Chervil	Anthriscus cerefolium (L.) Hoffm.
56	Chest nut leaves	Castanea dentata (Marsh.) Borkh
57	Chicory	Cichorium intybus L.

No.	General Name	Origin Name
58	Chirata	Swertia chirata Buch. Ham
59	Cinchona, red, bark	Cinchona succirubra Pav. Or its hybrids
60	Cinchona, yellow, bark	Cinchona ledgeriana Moens, C. calisaya Wedd., or hybrids of these with other spp. Of Cinchona.
61	Cinnamon bark, Ceylon	Cinnamomum zeylanicum Nees.
62	Cinnamon bark, Chinese	Cinnamomum cassia Blume.
63	Cinnamon bark, Saigon	Cinnamomum loureirii Nees.
64	Cinnamon leaf, Ceylon	Cinnamomum zeylanicum Nees.
65	Cinnamon leaf, Chinese	Cinnamomum cassia Blume.
66	Cinnamon leaf, Saigon	Cinnamomum loureirii Nees.
67	Citronella	Cymbopogon nardus Rendle.
68	Citrus peels	Citrus spp.
69	Civet(Zibeth, Zibet, Zibetum)	Civet cats, Viverra civetta Schreber and Viverra zibetha Schreber.
70	Clary(Clary sage)	Salvia sclarea L.
71	Clover	Trifolium spp.
72	Coca(decocainized)	Erythroxyllum coca Lam. And other spp. Of Erythroxyllum.
73	Coffee	Coffea spp.
74	Cognac oil, white and green	Ethyl oenanthata, so called.
75	Cola nut(Cola nut)	Cola acuminata Schott and Endl., and other spp. of Cola.
76	Copaiba	South American spp.of Copaifera L.
77	Coriander	Coriandrum sativum L.

78	Cork, oak	Quercus suber L., Q.occidentalis F. Gay, Q.acutissima, Q.mongolica, Q.serrata
----	-----------	--

No.	General Name	Origin Name
79	Costmary	Chrysanthemum balsamita L.
80	Costus root	Saussurea lappa Clarke.
81	Cumin(Cummin)	Cuminum cyminum L.
82	Curacao orange peel (Orange, bitter peel)	Citrus aurantium L.
83	Currant, black, buds and leaves	Ribes nigrum L.
84	Cusparia bark	Galipea officinalis Hancock.
85	Damiana leaves	Turnera diffusa Willd.
86	Dandelion	Taraxacum officinale Weber and T. laevigatum DC.
87	Dandelion root	Taraxacum officinale Weber and T. laevigatum DC.
88	Davana	Artemisia pallens Wall.
89	Dill, Indian	Anethum sowa Roxb., (Pucedanum graveolens Benth et Hook., Anethum graveolens L.)
90	Dittany(Fraxinella) roots	Dictamnus albus L.
91	Dittany of Crete	Origanum dictamnus L.
92	Dog grass(Quackgrass, Triticum)	Agropyron repens(L.) Beauv.
93	Dragon's blood (Dracorubin)	Daemonorops spp.
94	Elder tree leaves	Sambucus nigra L.
95	Elder flowers	Sambucus canadensis L. and S. nigra L.
96	Elecampane rhizome and roots	Inula helenium L.
97	Elemi	Canarium commune L. or C. luzonicum Miq.
98	Erigeron	Erigeron canadensis L.

No.	General Name	Origin Name
99	Estragole(Estragon, Esdragol, Esdragon, Tarragon)	Artemisia dracunculus L.
100	Eucalyptus globulus leaves	Eucalyptus globulus Labill.
101	Fennel, sweet	Foeniculum vulgare Mill.
102	Fenugreek	Trigonella foenum graecum L.
103	Fir("pine")needles and twigs	Abies sibirica Ledeb., A. alba Mill., A. sachalinesis Masters or A. mayriana Miyabe et Kudo.
104	Fir, balsam, needles and twigs	Abies balsamea(L.) Mill.
105	Galanga(Galangal)	Alpinia officinarum Hance.
106	Galanga, greater	Alpinia galanga Willd.
107	Galbanum	Ferula galbaniflua Boiss. Et Buhse and other Ferula spp.
108	Gambir(Catechu, Pale)	Uncaria gambir Roxb.
109	Genet flowers	Spartium junceum L.
110	Gentian, stemLess	Gentiana acaulis L.
111	Gentian rhizome or roots	Gentiana lutea L.
112	Geranium	Pelargonium spp.
113	Geranium, East Indian	Cymbopogon martini Stapf.
114	Geranium, rose	Pelargonium graveolens L'Her.
115	Germander, chamaedrys	Teucrium chamaedrys L.
116	Germander, golden	Teucrium polium L.
117	Ginger	Zingiber officinale Rosc.
118	Grapefruit	Citrus paradisi Macf.

119	Guaiac	Guaiacum officinale L., G. santum L., Bulnesia sarmienti Lor.
-----	--------	--

No.	General Name	Origin Name
120	Guarana	Paullinia cupana HBK.
121	Guava	Psidium spp.
122	Haw, black, bark	Viburnum dilatatum Thunb.
123	HemLock needles 및 twigs	Tsuga canadensis(L.) Carr. Or T. heterophylla(Raf.) Sarg
124	Hickory bark	Carya spp.
125	Horehound(Hoarhound)	Marrubium vulgare L.
126	Hops	Humulus lupulus L.
127	Horsemint	Monarda punctata L.
128	Hyacinth flowers	Hyacinthus orientalis L.
129	Hyssop	Hyssopus officinalis L.
130	Iceland moss	Cetraria islandica Ach
131	Immortelle	Helichrysum augustifolium DC.
132	Imperatoria	Peucedanum ostruthium (L.) Koch(Imperatoria ostruthium L.)
133	Jasmine	Jasminum officinale L. and other spp. Of Jasminum.
134	Juniper(berries)	Juniperus communis L.
135	Labdanum	Cistus spp.
136	Laurel berries	Laurus nobilis L.
137	Laurel leaves	Laurel (Laurus spp.
138	Lavender	Lavandula officinalis Chaix.
139	Laverder, spike	Lavandula latifolia Vill.
140	Lavandin	Hybrids between Lavandula
141	Lemon	Citrus limon(L.) Burm. f.
142	Lemon grass	Cymbopogon citratus DC. and Cymbopogon lexeosus Stapf.
143	Lemon peel	Citrus limon (L.) Burm. f.

144	Lime	Citrus aurantifolia Swingle.
145	Linaloe wood	Bursera delpechiana Poiss. and other Bursera spp.
146	Linden flowers	Tilia spp.

No.	General Name	Origin Name
147	Linden leaves	Tillia spp.
148	Locust bean(Carob bean)	Ceratonia siliqua L.
149	Lovage	Levisticum officinale Koch
150	Lungmoss (Lungwort)	Sticta pulmonacea Ach.
151	Lupulin	Humulus lupulus L.
152	Mace	Myristica fragrans Houtt.
153	Maidenhair fern	Adiantum capillus-veneris L.
154	Mandarin	Citrus reticulata Blanco.
155	Maple, mountain	Acer spicatum Lam.
156	Marjoram, sweet	Majorana hortensis Moench.
157	Mate	Ilex paraguariensis St. Hil.
158	Menthol	Mentha spp.
159	Menthyl acetate	Mentha spp.
160	Mimosa(Black wattle) flowers	Acadia decurrens Willd. var. dealbata
161	Molasses(extract)	Saccharum officinarum L.
162	Mullein flowers	Verbascum phlomoides L. or V. thapsiforme Schrad.
163	Musk(Tonquin musk)	Musk deer, Moschus moschiferus L.

No.	General Name	Origin Name
164	Mustard	Brassica spp.
165	Myrrh	Commiphora molmol Engl., C. abyssinica (Berg) Engl., or other Commiphora spp.
166	Myrtle leaves	Myrtus communis L.
167	Naringin	Citrus paradisi Macf.
168	Neroli, bigarade	Citrus aurantium L.
169	Nutmeg	Myristica fragrans Houtt.
170	Olibanu	Boswellia carteri Birdw. and other Boswellia spp.
171	Onion	Allium cepa L.
172	Opopanax(Bisabolmyrrh)	Opopanax chironium Koch (true opopanax) of Commiphora erythraea Engl. var. Llabrescens.
173	Orange, bitter, flowers	Citrus aurantium L.
174	Orange, bitter, peel	Citrus aurantium L.
175	Orange, sweet	Citrus sinensis (L.) Osbeck.
176	Orange, sweet, flowers	Citrus sinensis (L.) Osbeck.
177	Orange, sweet, peel	Citrus sinensis (L.) Osbeck.
178	Orange leaf	Citrus sinensis (L.) Osbeck.
179	Origanum	Origanum spp.
180	Orris root	Iris germanica L.(including its variety florentina Dykes) and I. pallida Lam.

No.	General Name	Origin Name
181	Palmarosa	Cymbopogon martini Stapf.
182	Paprika	Capsicum annum L.
183	Parsley	Petroselinum crispum(Mill.) Mansf.
184	Passion flower	Passiflora incarnata L.
185	Patchouly	Pogostemoncablin Benth. And P. heyneanusBenth.
186	Peach leaves	Prunus persica (L.) Batsch
187	Peach kernel (Persic oil)	Prunus persica Sieb. Et Zucc.
188	Peanut stearine	Arachis hypogaea L.
189	Pennyroyal, American	Hedeoma pulegioides(L.) Pers
190	Pennyroyal, European	Mentha pulegium L.
191	Pepper, black	Piper nigrum L.
192	Pepper, white	Piper nigrum L.
193	Peppermint	Mentha piperita L.
194	Peruvian balsam	Myroxylon pereirae klotzsch.
195	Petitgrain	Citrus aurantium L.
196	Petitgrain lemon	Citrus limon(L.) Burm .f.
197	Petitgrain mandarin or tangerine	Citrus reticulata Blanco.
198	Pimenta(Allspice)	Pimenta officinalis Lindl.
199	Pimenta leaf	Pimenta officinalis Lindl.
200	Pine, dwarf, needles, and twigs	Pinus mugo Turra var. pumilio (Haenke) Zenari

No.	General Name	Origin Name
201	Pine, Scotch, needles, and twigs	<i>Pinus sylvestris</i> L.
202	Pine, white, bark	<i>Pinus strobus</i> L.
203	Pine, white oil	<i>Pinus palustris</i> Mill., and other <i>Pinus</i> spp.
204	Pipsissewa leaves	<i>Chimaphila umbellata</i> Nutt.
205	Pomegranate	<i>Punica granatum</i> L.
206	Poplar buds	<i>Populus balsamifera</i> L.(<i>P.tacamahacca</i> Mill.), <i>P. candicans</i> Ait., or <i>P. nigra</i> L.
207	Prickly ash bark	<i>Xanthoxylum</i> (or <i>Zanthoxylum</i>) <i>Americanum</i> Mill. Or <i>Xanthoxylum</i> <i>clavaherculis</i> L.
208	Quassia	<i>Picrasma excelsa</i> (Sw.) Planch, or quassia (<i>Quassia amara</i> L.)
209	Quebracho bark	<i>Aspidosperma quebracho-</i> blanco Schlecht, or (<i>Quebrachia lorentzii</i> (Griseb)).
210	Quillaia (Soapbark)	<i>Quillaja saponaria</i> Mol
211	Quince seed	<i>Cydonia oblonga</i> Miller.
212	Red saunders (Red sandalwood)	<i>Pterocarpus san alinus</i> L.
213	Rhatany root	<i>Krameria triandra</i> Ruiz et Pav. Or <i>K.</i> <i>argentea</i> Mart.
214	Rhubarb, garden root	<i>Rheum rhaponticum</i> L.
215	Rhubarb root	<i>Rheum officinale</i> Baill., <i>R. palmatum</i> L., or other spp.(excepting <i>R. rhaponticum</i> L.) or hybrids of <i>Rheum</i> grown in China.
216	Rose absolute	<i>Rosa alba</i> L., <i>Rosa centifolia</i> L., <i>Rosa</i> <i>damascena</i> Mill., <i>Rosa gallica</i> L., and vars. of these spp.

217	Rose (otto of roses, attar of roses)	Rosa alba L., Rosa centifolia L., Rosa damascena Mill., Rosa gallica L., and vars. of these spp.
-----	--------------------------------------	--

No.	General Name	Origin Name
218	Rose buds	Rosa alba L., Rosa centifolia L., Rosa damascena Mill., Rosa gallica L., and vars. of these spp.
219	Rose flowers	Rosa alba L., Rosa centifolia L., Rosa damascena Mill., Rosa gallica L., and vars. of these spp.
220	Rose fruits(hips)	Rosa alba L., Rosa centifolia L., Rosa damascena Mill., Rosa gallica L., and vars. of these spp.
221	Rose geranium	Pelargonium graveolens L'Hdr.
222	Rose leaves	Rosa spp.
223	Rosemary	Rosmarinus officinalis
224	Saffron	Crocus sativus L.
225	Sage	Salvia officinalis L.
226	Sage, Greek	Salvia triloba L.
227	Sage, Spanish	Salvia lavandulaefolia Vahl.
228	St. John's loaf bread	Ceratonia siliqua L.
229	St. Johnswort leaves, flowers, and caulis	Hypericum perforatum L.
230	Sandalwood, white(yellow, or East Indian)	Santalum album L.
231	Sandarac	Tetraclinis articulata(Vahl.), Mast
232	Sarsaparilla	Smilax aristolochiaefolia Mill., (Mexican sarsaparilla), S. regelii Killip et Morton(Honduras sarsaparilla), S. febrifuga Kunth (Ecuadorean sarsaparilla), or undetermined Smilax spp.(Ecuadorean or Central Americal sarsaparilla).

No.	General Name	Origin Name
233	Sassafras leaves	Sassafras albidum (Nutt.) Nees
234	Savory, summer	Satureia hortensis L.
235	Savory, winter	Satureia Montana L.
236	Schinus molle	Schinus molle L.
237	Senna, Alexandria	Cassia acutifolia Delile
238	Simaruba bark	Simaruba amara Aubl
239	Sloe berries (Blackthorn berries)	Prunus spinosa L.
240	Snakeroot, Canadian (Wild ginger)	Asarum canadense L.
241	Spearmint	Mentha spicata L.
242	Spike lavender	Lavandula latifolia Vill.
243	Spruce needles and twigs	Picea glauca(Moench) Voss or P. mariana(Mill.) BSP.
244	Storax(Styrax)	Liquidambar orientalis Mill. or L. styraciflua L.
245	Tamarind	Tamarindus indica L.
246	Tangerine	Citrus reticulata Blanco.
247	Tansy	Tanacetum vulgare L.
248	Tea	Thea sinensis L.
249	Thistle, blessed(Holy thistle)	Onicus benedictus L.
250	Thyme	Thymus vulgaris L. andThymus zygis var. gracils Boiss.
251	Thyme, white	Thymus vulgaris L. and Thymus zygis var. gracils Boiss.
252	Thyme, wild or creeping	Thymus serpyllum L.

No.	General Name	Origin Name
253	Tuberose	Polianthes tuberosa L.
254	Tolu	Myroxylon balsamum (L.) Harms
255	Turmeric	Curcuma longa L.
256	Valerian rhizome and roots	Valeriana officinalis L.
257	Vanilla	Vanilla planifolia andr. Or Vanilla tahitensis. J. W. Moore.
258	Veronica	Veronica officinalis L.
259	Vervain, European	Verbena officinalis Linne Verbena officinalis
260	Vetiver	Vetiveria zizanioides Stapf.
261	Violet, Swiss	Viola calcarata L.
262	Violet, flowers	Viola odorata L.
263	Violet, leaves	Viola odorata L.
264	Violet, leaves absolute	Viola odorata L.
265	Walnut husks (hulls), leaves and green nuts	Juglans nigra L. or J. regia L.
266	Wild cherry bark	Prunus serotina Ehrh.
267	Woodruff, sweet	Asperula odorata L.
268	Yucca, Joshua tree	Youcca brevifolia Engelm
269	Ylang ylang	Cananga odorata Hook. F. and Thoms.
270	Yucca, Mohave	Yucca schidigera Roezl ex Ortgies (Y. Mohavensis Sarg)
271	Zedoary bark	Curcuma zedoaria Rosc.
272	Mastic	Pistacia lentiscus LINNE
273	Para cress	<i>Spilanthesacmella</i> Linné
274	Other natural flavoring substances : flavorings obtained by manufacturing/processing raw food materials that are appropriate for '1. Food Ingredient Standards' in 'Chapter 2. Common Standards and	

	Specifications for General Foods' in 「Food Code」.
--	---

Synthetic Flavoring Substances

Definition There are synthetic flavoring substances for flavorings as follows. However, this item includes two or more simple combinations of the following flavors in a way that does not cause any chemical changes. Water, spirits(ethyl alcohol), propylene glycol, triacetin, glycerin can be added for dilution, dissolution, dispersion, etc.

Order	General Name	Synonyms
A001	Acetal	Ethylidene diethyl acetal; acetaldehyde diethyl acetal; diethyl acetal; 1,1- Diethoxyethane; Ethylidene diethyl ether; 1,1-Diethoxyethane
A002	Acetaldehyde	Acetic aldehyde; Ethanal; Ethyl aldehyde
A003	Acetaldehyde butyl phenethyl acetal	2-Butoxy-2-phenylethoxy-ethane; 1-Butoxy-1-(2-phenylethoxy)ethane
A004	Acetaldehyde diisoamyl acetal	Butane, 1,1'-[ethylidenebis(oxy)]bis[3-methyl]-, 3-Methyl-1-[1-(3-methyl-butoxy)- ethoxy]-butane
A005	Acetaldehyde ethyl cis-3-hexenyl acetal	Ethyl cis-3-hexenyl acetal; cis-1-(ethoxyethoxy)-3-hexene; 1-Ethoxy-1-(cis-3- hexenyloxy)ethane, Leaf acetal; Leaf alcohol ethyl acetal; Acetaldehyde ethyl (Z)-3-hexenyl acetal; 1- Ethoxy-1-(3-hexenyloxy)ethane; Acetaldehyde ethyl 3-hexenyl acetal
A006	Acetaldehyde phenethyl propyl acetal	Benzene, 2-(1-propoxyethoxy)ethyl; Acetal R; pepital; 1-Phenethoxy-1- propoxy-ethane; Propyl phenethyl acetal; 2-(1-Propoxyethoxy)ethyl]benzene
A007	Acetamide	Acetic acid amide; Acetimidic acid; Ethanamide; Ethanamidic acid; Methanecarboxamide

Order	General Name	Synonyms
A008	Acetanisole	Methyl 4-methoxyphenyl ketone; 4-Acetylanisole; p-Acetyl anisole; p-Methoxy- acetophenone; Navatone; 1-(4-Methoxyphenyl)ethanone; 4-Methoxyacetophenone
A009	Acetoin	Acetyl methyl carbinol; 2,3-Butanolone; Dimethylketol; 3-Hydroxy-2-butanone; γ -hydroxy- β -oxobutane; 3-Hydroxybutan-2-one; Acetoin
A010	Acetophenone*	Acetylbenzol; Phenyl methyl ketone; Benzoylmethide; Acetyl benzene; Hypnone; Methyl phenyl ketone; 1-Phenylethanone
A011	2-Acetoxy-3-butanone	1-Methyl-2-oxopropyl acetate; sec-Butan-3-onyl acetate; Acetoin acetate; acetyl methyl carbonyl acetate; 2-Butanon-3-yl acetate; 2-Acetoxy-3-butanone
A012	6-Acetoxydihydrotheaspirane	(2 <i>RS</i> ,5 <i>SR</i> ,6 <i>SR</i>)-2,6,10,10-Tetramethyl-1-oxaspiro[4,5]dec-6-yl acetate; 2,6,10,10-Tetramethyl-1-oxaspiro(4.5)dec-6-yl acetate
A013	4-(p-Acetoxyphenyl)-2-butanone	4-(p-Hydroxyphenyl)-2-butanone acetate; 4-(3-Oxobutyl)phenylacetate; p-(2-Acetylethyl)phenylacetate; 4-(4-Acetoxyphenyl)butan-2-one
A014	2-Acetyl-1-methylpyrrole	1-Methyl-2-acetylpyrrole; methyl 1-methylpyrrol-2-yl ketone; 1-methylpyrrol-2-yl methyl ketone; 2-acetyl-n-methyl pyrrol
A015	2-Acetyl-1-pyrroline	
A016	3-Acetyl-2,5-dimethylfuran	2,5-Dimethyl-3-acetyl furan
A017	4-Acetyl-2,5-dimethylfuran-3(2H)-one	4-Acetyl-2,5-dimethyl-3(2H)-furanone
A019	4-Acetyl-2-methylpyrimidine	Ethanone, 1-(2-methyl-4-pyrimidinyl)-
A020	2-Acetyl-2-thiazoline	2-Acetyl-4,5-dihydrothiazole; acetylthiazoline-2; Acetyl thiazoline-2; 2-Acetyl-4,5-dihydrothiazole

Order	General Name	Synonyms
A021	2-Acetyl-3,(5 or 6)-dimethylpyrazine	3-Acetyl-2,5-dimethylpyrazine; 2-Acetyl-3,5-dimethylpyrazine and 3-acetyl-2,5- dimethylpyrazine; 3-Acetyl-2,5-dimethylpyrazine and 3-acetyl-2,6-dimethylpyrazine mixture
A022	2-Acetyl-3,5-dimethylfuran	1-(3,5-Dimethyl-2-furanyl)ethanol; 5-Dimethyl-2-furyl methyl ketone
A023	2-Acetyl-3-ethylpyrazine	2-Acetyl-3-ethyl-1,4-diazine; 3-Ethyl-2-pyrazinyl methyl ketone; 2-Ethyl-3-pyrazinyl methyl ketone
A024	2-Acetyl-3-methylpyrazine	Ethanone, 1-(3-Methylpyrazinyl)-; 1-(3-Methylpyrazinyl)ethan-1-one; 2-Methyl-3-acetylpyrazine; 3-Acetyl-2-methylpyrazine; Ketone, methyl 3-methylpyrazinyl; 2-Acetyl-3-methyl-1,4-diazine
A025	2-Acetyl-5-methylfuran	Ethanone, 1-(5-Methyl-2-furanyl)-; 1-(5-Methyl-2-furyl)ethanone; Methyl 5-methyl-2-furyl ketone; 1-(3-Methyl-2-furyl)ethanone
A026	4-Acetyl-6-tert-butyl-1,1-dimethylindan	Celestolide; Crysolide; Ethanone, 1-[6-1,1-Dimethylethyl)-2,3-dihydro-1,1-dimethyl- 1H-indane; 4-Acetyl-6-(1,1-dimethylethyl)-1,1-dimethylindane; 4- Acetyl-6-t- butyl-1,1-dimethylindane; Celestolide; 4-Acetyl-1,1-dimethyl-6-tert-butylindane
A027	3-(Acetylmercapto)hexyl acetate	3-Acethylthiohexyl acetate; 3-Acetylthiohexyl ethanoate
A028	2-Acetylpyrazine	Acetylpyrazine; Methylpyrazinyl ketone; 2-Acetylpyrazine
A029	acetylpyridine	2-Acetylpyridine; Methyl-2-pyridyl ketone; 2-Acetopyridine
A030	3-Acetylpyridine	Methyl pyridyl ketone; Methyl β -pyridyl ketone; 1-(3-Pyridinyl)ethanone; β -Acetylpyridine; Methyl-3-pyridyl ketone
A031	2-Acetylthiazole	2-Thiazolyl methyl ketone; Methyl-2-thiazolyl ketone; 5-Acetyl thiazole; methyl-5- thiazolyl ketone; 1-(Thiazol-2-yl)ethan-1-one; Ethanone, 1-(2-thiazolyl)-; 2-Thiazolyl methyl ketone

Order	General Name	Synonyms
A032	Aconitic acid	2-Carboxyglutaconic acid; 1,2,3-Propenetricarboxylic acid; Achilleic acid; Citridic acid; equisetic acid; 1-Propene-1,2,3-tricarboxylic acid; Prop-1-ene-1,2,3-tricarboxylic acid; Aconitic acid
A033	Adenosine monophosphate	Adenosine 5 -monophosphate sodium salt; ; Mono- or Disodium adenylate
A034	Aldehyde C ₁₆	Ethyl methylphenylglycidate; Ethyl α,β -epoxy- β -methyl-hydrocinnamate; Ethyl α,β epoxy- β -methylphenyl propionate; Ethyl 2,3-epoxy-3-phenyl-butanoate; 3-Methyl-3-phenyl glycidic acid ethyl ester; Ethyl 2,3-epoxy-3-methyl-3- phenylpropionate; Ethyl 2,3-epoxy-3-phenylbutyrate; Ethyl 3-methyl-3-phenylglycidate
A035	Allyl 10-undecenoate	2-Propenyl 10-undecenoate; Allyl hendecenoate; Allyl undecylenate; allyl undecylenoate; Allyl 10-undecylenate
A036	Allyl 2-ethylbutyrate	2-Propenyl furan-2-ethylbutanoate; 2-Propenyl 2-ethylbutyrate; Allyl 2-ethylbutanoate; 2-Propenyl 2-ethylbutanoate
A037	Allyl 2-furoate	Allyl furan-2-carboxylate; Allyl pyromucate; 2-Furancarboxylic acid; 2-Propenyl ester; 2-Propenyl 2-furoate; 2-Propenyl furan-2-carboxylate
A038	Allyl α -ionone	Allyl ionone; Allyl cyclocitryllideneacetone; Butenyl α -cyclocitrylidenemethyl ketone; α -Cyclocitrylidenemethyl butenyl ketone; 1-(2,6,6-Trimethyl-2-cyclohexen-1-yl)-1,6-heptadiene-3-one; α -Allylionone
A039	Allyl anthranilate	2-Propenyl anthranilate; 2-Propenyl 2-aminobenzoate; Allyl 2-aminobenzoate; Allyl o-aminobenzoate; Vinyl carbonyl anthranilate
A040	Allyl butyrate	Butenoic acid, 2-propenylester; 2-Propen-1-yl butenoate, 2- Propenyl butyrate; Allyl butanoate; Allyl-n-butyrate; Vinyl carbonyl butyrate

Order	General Name	Synonyms
A041	Allyl cinnamate	Vinyl carbiny cinnamate; Cinnamic acid, allyl ester; 2-propen-1-yl 3-phenyl-2-propenoate; Allyl 3-phenylpropenoate; Allyl β -phenylacrylate; propenyl cinnamate; 2-Propenyl 3-phenyl-2-propenoate; Allyl- β -phenylacrylate; Propenyl cinnamate
A042	Allyl crotonate	2-Butenoic acid, 2-propenyl ester; Crotonic acid, allyl ester
A043	Allyl cyclohexaneacetate	Allyl cyclohexylacetate; 2-Propenyl cyclohexaneacetate; 2-Propen-1-yl cyclohexaneacetate
A044	Allyl cyclohexanebutyrate	Allyl 4-cyclohexylbutyrate; 2-Propen-1-yl cyclohexanebutyrate; Allyl hexahydrophenylbutyrate; Allyl cyclohexyl-n-butylate, 2-propenyl 4-cyclohexylbutyrate
A045	Allyl cyclohexanehexanoate	Allyl 6-cyclohexanehexanoate; 2-Propen-1-yl cyclohexanecaproate; allyl hexahydrophenylhexanoate, 2-propenyl 6-cyclohexanehexanoate; Allyl cyclohexylcaproate; Allyl cyclohexylcaproate; Allyl 3-cyclohexylhexanoate; Allyl cyclohexanecaproate
A046	Allyl cyclohexanepropionate*	Allyl cyclohexylpropionate; Allyl 3-cyclohexylpropionate; Allyl β -cyclohexylpropionate; 2-propen-1-yl cyclohexanepropionate; Allyl hexahydrophenylpropionate
A047	Allyl cyclohexanevalerate	Allyl 5-cyclohexylpentanoate; Allyl cyclohexanepentanoate; 2-Propen-1-yl cyclohexanevalerate; 2-Propen-1-yl cyclohexanepentanoate; Allyl hexahydrophenylvalerate; Allyl cyclohexylvalerate; 2-Propenyl 5-cyclohexanepentanoate
A048	Allyl disulfide	Diallyl disulfide; 2-Propenyl disulphide
A049	Allyl heptanoate	Allyl enanthate; Allyl heptylate; Allyl heptoate; Allyl oenanthate; 2-Propenyl heptanoate

Order	General Name	Synonyms
A050	Allyl hexanoate*	Allyl caproate; Allyl capronate; 2-Propenyl hexanoate
A051	Allyl isothiocyanate*	2-Propenyl isothiocyanate; Allyl thiocarbonimide; Allyl isosulfocyanate; Allinat(H&R); 3-Isouthiocyanatopropene; Isothiocyanic acid, allyl ester
A052	Allyl isovalerate	Allyl isovalerianate; Allyl isopentanoate; 2-Propenyl 3-methylbutanoate; 2-Propenyl isovalerate; 2-propenyl isopentanoate; Allyl 3-methylbutanoate
A053	Allyl mercaptan	Allyl sulfhydrate; Allylthiol; 2-Propene-1-thiol; 2-Propene-1-thiol
A054	Allyl methyl disulfide	Methyl allyl disulfide; Methyl allyl disulphide
A055	Allyl methyl trisulfide	Methyl allyl trisulfide; Methyl allyl trisulphide
A056	Allyl nonanoate	2-Propenyl nonanoate; Allyl nonylate; 2-Propenyl pelargonate; Allyl pelargonate
A057	Allyl octanoate	2-Propenyl octylate; 2-Propenyl octanoate; Allyl caprylate; Allyl octylate
A058	Allyl phenoxyacetate	2-propenyl phenoxyacetate; Acetic acid, phenoxy, allyl ester; Acetate PA
A059	Allyl phenylacetate	Acetic acid, phenyl, allyl ester, 2-propenyl phenylacetate; Allyl α -toluate
A060	Allyl propionate	2-Propenyl propanoate; Allyl propanoate
A061	Allyl propyl disulfide	Disulfide, 2-propenyl propyl; Disulfide, allyl propyl; 2-Propenyl propyl disulfide, 4,5-dithia-1-octene; Propyl allyl disulfide
A062	Allyl sorbate	2-Propenyl 2,4-hexadienoate; Allyl-2,4-hexadienoate, 2-propenyl sorbate; Allyl hexa-2,4-dienoate
A063	Allyl sulfide	2-Propenyl sulfide; Diallyl sulfide; Thioallyl ether; 2-Propenyl sulfide,3,3'-thiobispropene; 2-Propenyl sulphide
A064	Allyl thiohexanoate	Hexanethioic acid, S-2-propenyl ester
A065	Allyl thiopropionate	Thioallyl ester, Propionic acid; Thioacrylic ester, thiopropionic acid, allyl ester

Order	General Name	Synonyms
A066	Allyl tiglate	Allyl 2-methylcrotonate; Allyl-trans-2,3-dimethylacrylate; Allyl-trans-2-methyl-2-butenolate; 2-propenyl tiglate
A067	Allyl valerate	Pentanoic acid, 2-propenyl ester; Valeric acid, allyl ester; Allyl pentanoate
A068	4-Allyl-2,6-dimethoxyphenol	4-Allylsyringol; 6-Methoxy eugenol; Phenol, 2,6-dimethoxy-4-(2-propenyl)-; 4-Methoxyeugenol
A069	4-Allylphenol	Phenol, 4-(2-propenyl)-; Chavicol; Phenol, <i>p</i> -allyl; 3-(<i>p</i> -Hydroxyphenyl)-1-propene; <i>p</i> -Hydroxyallylbenzene; <i>p</i> -Allylphenol
A070	1-Amino-2-propanol	Isopropanolamine; (RS)-1-Amino-2-propanol; DL-1-Amino-2-propanol; α -Aminoisopropyl alcohol; β -Aminoisopropanol; 1-Amino-2-hydroxypropane; 1-Methyl-2-aminoethanol; 2-Hydroxy-1-methylethanol; 2-Hydroxy-1-propylamine threanine
A071	2-Aminoacetophenone	1-Acetyl-2-aminobenzene; <i>o</i> -Acetylaniline; 2-Acethylaniline; 2-Acetylphenylamine; <i>o</i> -Aminoacetophenone; <i>o</i> -Aminoacetylbenzene; 2-Aminophenyl methyl ketone; <i>o</i> -Aminophenyl methyl ketone; Methyl 2-aminophenyl ketone
A072	Ammonium isovalerate	Isovaleric acid, ammonium salt; Ammonium isovalerianate; Ammonium 3-methylbutanoate; Butanoic acid, 3-methyl-, ammonium salt
A073	Ammonium sulfide	Diammonium sulfide; Ammonium monosulfide
A074	Amyl 2-furoate	Amyl furan-2-carboxylate; Furancarboxylic acid, pentyl ester; Pentyl furan-2-carboxylate; Pentyl-2-furoate; 2-Furoic acid; <i>n</i> -Pentyl furan-2-carboxylate
A075	Amyl alcohol	<i>n</i> -Butyl carbinol; 1-Pentanol; pentyl alcohol
A076	N-Amyl butyrate	Amyl butanoate; Pentyl butanoate; Pentyl butylrate; Amyl butyrate
A077	N-Amyl formate	Amyl formate; Amyl methanoate; <i>n</i> -Pentyl methanoate; Pentyl formate

Order	General Name	Synonyms
A078	N-Amyl heptanoate	Pentyl heptanoate; Amyl heptanoate; Amyl heptylate; Amyl heptoate; Amyl oenanthate,
A079	N-Amyl hexanoate	Amyl caproate; Amyl hexylate; pentyl hexanoate; n-Pentyl hexanoate; Amyl hexanoate; Pentyl caproate
A080	Amyl methyl disulfide	Disulfide,methyl pentyl; 1-Methyldisulfanylpentane; 2,3-Dithiaoctane
A081	N-Amyl octanoate	Pentyl octylate; Amyl caprylate; Amyl octylate; pentyl octanoate; n-Pentyl octylate; Amyl octanoate
A082	2-Amyl-(5 or 6)-keto-1,4-dioxane	2-Pentyl-5 or 6-keto-1,4-dioxane; 1,4-Dioxan-2-one, 5(or 6)-pentyl-5(or 6)-pentyl-1,4-dioxan-2-one; 5(or 6)-Pentyl-1,4-dioxan-2-one; 5-Pentyl-1,4- dioxan-2-one
A083	α -Amylcinnamaldehyde*	Buxine; α -Pentyl- β -phenylacrolein; Flomine; Jasmine aldehyde; Floxine; Jasmonal; flosal; Amyl cinnamal; Amyl cinnamic aldehyde; α -Amyl- β -phenyl-acrolein; 2-Benzylidene heptanal; α -Pentyl-cinnamaldehyde; α -Amylcinnamaldehyde
A084	α -Amylcinnamaldehyde dimethyl acetal	α -n-Amylcinnamal, dimethyl acetal; α -Pentylcinnamaldehyde, dimethyl acetal; α -n-Amyl- β -phenylacroleindimethylacetal; 1,1-Dimethoxy-2-amyl-3-phenyl-2-propene; 1,1-Dimethoxy-2-benzylidene-heptane; (2-(Dimethoxymethyl)-1-heptenyl)benzene, α -amyl- β -phenylacrolein dimethyl acetal; 1,1-Dimethoxy-2-benzylideneheptane; α -Pentylcinnamaldehyde dimethyl acetal
A085	α -Amylcinnamyl acetate	Ammyl cinnamyl acetate; Acetic acid, α -amylcinnamyl ester; α -n-Amyl- β -phenylacryl acetate; Floxin acetate; α -Pentylcinnamyl acetate; 2-(Phenylmethylene)heptyl acetate
A086	α -Amylcinnamyl alcohol	2-Benzylideneheptanol; n-Amyl cinnamic alcohol; 2-Amyl-3-phenyl-2-propen-1-ol; 2-Benzylidene-heptanol; α -Pentylcinnamyl alcohol; 2-Phenyl-3-phenylprop-2-en-1-ol

Order	General Name	Synonyms
A087	α -Amylcinnamyl formate	α -n-Amyl- β -phenylacryl formate; α -Pentylcinnamyl formate; 2-(Phenylmethylene)heptyl formate; α -Amyl- β -phenylacryl formate; α -n-Amyl-phenylacryl formate
A088	α -Amylcinnamyl isovalerate	α -Amylcinnamyl isovalerianate; α -n-Amyl- β -phenylacryl 3-methylbutanoate; α -n-Amyl- β -phenylacryl isovalerate; Floxin isovalerate; α -Pentylcinnamyl isovalerate; 2-(Phenylmethylene)heptyl isovalerate; α -Amyl- β -phenylacryl isovalerate; α -Amylcinnamyl 3-methylbutyrate; Isovalerate
A089	trans-Anethole	trans-Methoxy-4(1-propenyl benzene; Anise camphor; 1-Methoxy-4-propenylbenzene; estragole iso; 1-Propene, 1-(4-methoxyphenyl); p-Methoxy- α -phenylpropene; Isoestragole; 1-Methoxy-4-propenyl benzene; p-Methoxypropenyl benzene; p-Propenyl anisole; p-Propenylphenyl methyl ether; 4-Methoxy-1-propenylbenzene; p-Methoxy- α -phenylpropene
A090	O-Anisaldehyde*	Benzaldehyde, 2-methoxy; 2-Anisaldehyde; 2-Methoxybenzaldehyde; 2-Methoxybenzenecarboxaldehyde; 2-Methoxyphenylformaldehyde; O-Formylanisole; O-Methoxybenzaldehyde; Salicylaldehyde methyl ether
A091	Anisole	Phenyl methyl ether; Benzene, methoxy; Methoxybenzene; Methyl phenyl ether
A092	Anisyl acetate	Benzyl alcohol, p-methoxy, acetate; Anisyl alcohol, acetate; 4-Methoxybenzyl acetate; cassi ketone; p-Anisyl acetate; p-Methoxybenzyl acetate; 1-Methoxy-4-acetoxymethylbenzene; Benzenemethanol, 4-methoxy-, acetate
A093	Anisyl alcohol	Benzyl alcohol,p-methoxy; Anise alcohol; p-Anisyl alcohol; Anisic alcohol; p-Methoxybenzyl alcohol; 4-Methoxybenzyl alcohol
A094	Anisyl butyrate	Butyric acid, p-methoxybenzyl ester; Butanoic acid, p-methoxybenzyl ester; Benzyl alcohol, p-methoxy, butyrate; p-Anisyl butyrate; p-Methoxybenzyl butyrate; 4-Methoxybenzyl butanoate; Anisyl butanoate

Order	General Name	Synonyms
A095	Anisyl formate	p-methoxybenzyl alcohol, formate; Anisyl methanoate; 4-methoxybenzyl formate; p-Methoxybenzyl methanoate; Anisyl alcohol, formate; p-Anisyl formate; p-Methoxybenzyl formate; Benzenemethanol, 4-methoxy-, formate
A096	Anisyl phenylacetate	Anisyl α -toluate; Benzenacetic acid, (4-methoxyphenyl)methyl ester; p-Methoxybenzyl phenylacetate; Phenylacetic acid p-methoxybenzyl ester; 4-Methoxybenzyl phenylacetate, Anisyl α -toluene
A097	Anisyl propionate	Benzyl alcohol p-methoxy, propionate; Propionic acid, p-methoxybenzyl ester; p-Anisyl propionate; p-Methoxybenzyl propionate; 4-Methoxybenzyl propanoate; Anisyl propanoate; Benzenemethanol; 4-Methoxy-, propionate
A098	Acetol acetate	2-Propanone, 1-hydroxy-, acetate; Acetonyl acetate; Acetoxyacetone; Acetoxypropanone; Acetylmethyl acetate; O-Acetylacetol; 1-Acetoxy-2-propanone; 1-Acetoxyacetone; 1-Hydroxy-2-propanone acetate; 2-Oxopropyl acetate; 1-(Acetyloxy)-2-propanone; acetoxy-2-propanone
A099	Amyl propionate	Propanoic acid, pentyl ester; Propionic acid, pentyl ester; n-Pentyl propionate; Pentyl propanate; Pentyl propionate; n-Pentyl propanoate; Amyl propanoate; N-Amyl n-propionate; pentyl propanoate
A100	Amyl isothiocyanate	Pentyl isothiocyanate; n-Amyl isothiocyanate; Pentane, 1-isothiocyanato-; 1-Isouthiocyanatopentane
A101	4-Acetylpyridine	Ketone, methyl 4-pyridyl; Methyl 4-pyridyl ketone; 4-Pyridyl methyl ketone; Pyridine, 4-acetyl-; γ -Acetylpyridine; 1-(4-Pyridinyl)ethanone
A102	Amyl benzoate	n-Pentyl benzoate; Pentyl benzoate; Benzoic acid, amyl ester; n-amyl benzoate
A103	Amyl salicylate	Benzoic acid, 2-hydroxy-, pentyl ester; Salicylic acid, pentyl ester; Pentyl salicylate; Amylester kyseliny salicylove; N-Amyl salicylate; Salicylic acid, amyl ester

Order	General Name	Synonyms
A104	Amyl valerate	Valeric acid, pentyl ester; Amyl valerianate; Pentyl pentanoate; Pentyl valerate; 1-Pentyl n-valerate; n-Pentyl valerate; Pentyl ester of pentanoic acid; N-Amyl N-valerate
A105	Amyl cinnamate	2-Propenoic acid, 3-phenyl-, pentyl ester; Cinnamic acid, pentyl ester; Pentyl cinnamate; Pentyl (2E)-3-phenyl-2-propenoate; n-amyl cinnamate
A106	Amyl decanoate	Pentyl decanoate
A107	Amyl lactate	Lactic acid, pentyl ester; Pentyl 2-hydroxypropanoate; Pentyl lactate
A108	Allyl methyl sulfide	1-Propene, 3-(methylthio)-; Methyl allyl sulfide; 3-(Methylthio)propene; 3-(Methylsulfanyl)-1-propene; 3-(methylthio)-1-propene; methyl 2-propenyl sulfide; Methylallyl sulphide; Sulfide, allyl methyl
A109	Amyl isovalerare	Butanoic acid, 3-methyl-, pentyl ester; Isovaleric acid, pentyl ester; Pentyl 3-methylbutyrate; 1-Pentyl isovalerate; Pentyl 3-methylbutanoate; Pentyl isovalerate; N-amyl isovalerate
A110	Allyl propyl sulfide	2-propenyl propyl sulfide; 4-thia-1-heptene
A111	Allyl prop-1-enyl disulfide	
A112	Allyl propyl trisulfide	Trisulfide, allyl propyl
A113	Acetaldehyde di-cis-3-hexenyl acetal	acetaldehyde hexenyl acetal
A114	Amyl 2-methyl butyrate	N-Amyl 2-methyl butyrate; Pentyl 2-methylbutanoate; n-amyl 2-methylbutanoate; pentyl 2-methylbutyrate; Butanoic acid, 2-methyl-, pentyl ester
A115	5-Acetyl-2,3-dihydro-1,4-thiazine	acetyl dihydro thiazine
A116	Acetaldehyde 1,3-octanediol acetal	
A117	Acetaldehyde hexyl isoamyl acetal	1-Hexyloxy-1-isopentyloxyethane; Acetaldehyde hexyl 3-methylbutyl acetal; hexyl oxy isopentyloxyethane; 1-Hexyloxy-1-isopentyloxyethane
A118	3{(4-Amino-2,2-dioxido-1H-2,1,3-benzothiadiazin-5-	3-(4-Amino-1H-benzo[c][1,2,6]thiadiazin-5-yloxy)-2,2-dimethyl-N-propylpropanamide-2,2-dioxide

Order	General Name	Synonyms
	yl)oxy]-2,2-dimethyl-N-propylpropanamide	
A119	Acetic acid*	Ethanoic acid
A120	Acetovanillone	
A121	3-(Acetylthio)-hexanal	
A122	S-Allyl-L-cysteine	(2R)-2-Amino-3-(prop-2-en-1-ylsulfanyl) propanoic acid; (2R)-3-(Allylthio)-2-aminopropanoic acid; (R)-Allylthio-2-aminopropanoic acid; S-Allylcysteine; (+)-S-Allylcysteine; S-2-Propenylcysteine
A123	4-Aminobutyric acid	gamma-Aminobutanoic acid; gamma-Aminobutyric acid; 3-Carboxypropylamine; 4-Aminobutanoic acid; 4-Aminobutyric acid; GABA
A124	4-Amino-5,6-dimethylthieno[2,3-d]pyrimidin-2(1H)-one	
A125	4-Amino-5,6-dimethylthieno[2,3-D]pyrimidin-2(1H)-one hydrochloride	
A126	3-[(4-Amino-2,2-dioxido-1H-2,1,3-benzothiadiazin-5-yl)oxy]-2,2-dimethyl-N-propylpropanamide	3-(4-Amino-1H-benzo[c][1,2,6]thiadiazin-5-yloxy)-2,2-dimethyl-N-propylpropanamide-2,2-dioxide; 3-[(4-Amino-2,2-dioxido-1H-2,1,3-benzothiadiazin-5-yl)oxy]-2,2-dimethyl-N-propyl-propanamide; (1Z)-N-{3-[(4-Imino-2,2-dioxido-3,4-dihydro-1H-2,1,3-benzothiadiazin-5-yl)oxy]-2,2-dimethylpropyl}propanimidic acid
A127	(3R,3S)-3-[[[(4-Amino-2,2-dioxido-1H-2,1,3-benzothiadiazin-5-yl)oxy)methyl]-N-cyclopentyl-2-oxo-3-piperidinecarboxamide	(3R,3S)-3-[[[(4-Amino-2,2-dioxido-1H-2,1,3-benzothiadiazin-5-yl)oxy)methyl]-N-cyclopentyl-2-oxopiperidine-3-carboxamide
A128	(S)-1-(3-(((4-Amino-2,2-dioxido-1H-benzo[c][1,2,6]thiadiazin-5-yl)oxy)methyl)piperidin-1-yl)-3-methylbutan-1-one	1-[(3S)-3-[[[(4-Amino-2,2-dioxido-1H-2,1,3-benzothiadiazin-5-yl)oxy)methyl]-1-piperidinyl]-3-methyl-1-butanone
A129	4-Amino-5-(3-(isopropylamino)-2,2-dimethyl-3-oxopropoxy)-2-methylquinoline-3-carboxylic acid	3-Quinolincarboxylic acid, 4-amino-5-[2,2-dimethyl-3-[(1-methylethyl)amino]-3-oxopropoxy]-2-methyl-

Order	General Name	Synonyms
A130	(2S,5R)-N-[4-(2-Amino-2-oxoethyl)phenyl]-5-methyl-2-(propan-2-yl)cyclohexanecarboxamide	4-Methyl-2-(1-[[[(2S,5R)-5-Methylethyl]cyclohexyl]carbonyl]amino]-benzeneacetamide; (2S,5R)-N-[4-(2-amino-2-oxo-ethyl)phenyl]-2-isopropyl-5-methyl-cyclohexanecarboxamide
A131	Amyl phenylacetate	
A132	beta-Angelicalactone	5-Methylfuran-2(5H)-one; 4-Methyl-2-butenolide; 4-Hydroxy-2-pentenoic acid gamma-lactone
B001	Benzaldehyde *	Bitter almond oil, synthetic; Benzenecarboxaldehyde, artificial; Benzenecarbonal; Benzenemethylal; Benzoic aldehyde; Benzene methylal
B002	Benzaldehyde dimethyl acetal	Dimethoxy-(phenyl)-methane; α,α -Dimethoxy toluene; (Dimethoxymethyl)benzene; 1,1-Dimethoxy phenyl methane
B003	Benzaldehyde glyceryl acetal	Benzaldehyde, cyclic acetal with glycerol; 4-Hydroxymethyl-2-phenyl-m-dioxolane; Benzalglycerin; 5-Hydroxy-2-phenyl-1,3-dioxane; Phenyl-m-dioxan-5-ol (α, α'); 2-phenyl-1,3-dioxan-5-ol (α, α'); 5-Hydroxy-2-phenyl-1,3-dioxane; 4-(Hydroxymethyl)-2-phenyl-1,3-dioxolane; 2-Phenyl-5-hydroxy-1,3-dioxane; 2-Phenyl-4-hydroxymethyl-1,3-dioxolane; 4-Hydroxy methyl-2-phenyl-1,3-dioxolan
B004	Benzaldehyde propylene glycol acetal	4-Methyl-2-phenyl-1,3-dioxolane; 4-Methyl-2-phenyl -m-dioxolane; Benzaldehyde propylene glycol cyclic acetal
B005	Benzenethiol	Phenyl mercaptan; Thiophenol
B006	2-Benzofurancarboxaldehyde	2-Formylbenzofuran
B007	Benzoin	α -Hydroxy- α -phenylacetophenone; Benzoyl phenylcarbinol; 2-Hydroxy-2-phenyl- acetophenone; 2-Hydroxy-1,2-diphenylethanone
B008	Benzophenone	Diphenylmethanone; α -Oxodiphenylmethane; phenyl ketone; Benzoyl benzene; diphenyl ketone

Order	General Name	Synonyms
B009	Benzothiazole	
B010	N-Benzoylanthranilic acid	2-Benzoylaminobenzoic acid; dianthramid B; Anthranilic acid, N-benzoyl-; 2-Carboxybenzanilide; N-(2-Carboxyphenyl)benzamide
B011	Benzyl 2,3-dimethylcrotonate	Benzyl 2,3-dimethyl-2-butenoate; Benzyl methyl tiglate; Benzyl 2,3-dimethyl-trans-2-butanoate; Benzyl 2,3-dimethyl-2-butenoate
B012	Benzyl 2-methoxyethyl acetal	benzyl methoxyethyl acetal; Acetaldehyde benzyl β -methoxyethyl acetal; 1-Benzoxo-1-(2-methoxyethoxy)ethane; 1-Benzyl-1-(β -methoxy)-ethoxyethane; Acetaldehyde benzyl 2-methoxyethyl mixed acetal; 1-Benzyl-1-(2-methoxyethoxy)ethane; Acetaldehyde benzyl methoxyethyl acetal; 1-Benzyl-1-(2-methoxyethoxy)ethane
B013	Benzyl acetate*	Benzyl ethanoate; Acetic acid, benzyl ester
B014	Benzyl acetoacetate	Benzyl acetyl acetate; benzyl β -ketobutyrate; benzyl 3-oxobutanoate; Benzyl 3-oxobutyrate
B015	Benzyl alcohol*	Phenylmethyl alcohol; α -Hydroxy toluene; phenyl carbinol; Phenyl methanol
B016	Benzyl benzoate	Benzoic acid, benzyl ester; Benzyl alcohol benzoic ester; Benzyl benzene carboxylate; Benzyl henylformate; Phenylmethyl benzoate
B017	Benzyl butyl ether	Butyl benzyl ether; n-Butyl benzyl ether
B018	Benzyl butyrate	Aldehyde C-19; butyric acid, benzyl ester; Benzyl butanoate; Benzyl n-butyrate; Phenylmethyl butyrate; Benzyl n-butanoate
B019	Benzyl cinnamate	Isobutyric acid, benzyl ester; Benzyl cinnamate; Benzyl 2-methyl propanoate; Benzyl 3-phenylpropenoate; Cinnamein; Benzyl β -phenylacrylate; 2-Propenoic acid, 3-phenyl, phenylmethyl ester
B020	Benzyl disulfide	α -Benzylidithio toluene; 1,4-Diphenyl-2,3-dithiobutane; Di(phenylmethyl)disulfide; α -(benzylidithio)toluene; 1,4-Diphenyl-1,2,3-dithiobutane; Di(phenylmethyl)disulfide

Order	General Name	Synonyms
B021	Benzyl ethyl ether	Ethyl benzyl ether
B022	Benzyl formate	Benzyl methanoate; Formic acid benzyl ester; Phenylmethyl formate
B023	Benzyl hexanoate	Hexanoic acid, Phenylmethyl ester; Hexanoic acid, benzyl ester; Benzyl caproate
B024	Benzyl isobutyrate	Benzyl cinnamate; Isobutyric acid, benzyl ester; Benzyl β -phenylacrylate; Benzyl-3-phenylpropenoate; Cinnamein; Phenylmethyl isobutyrate; Pineapple aldehyde c-19; Benzyl 2-methylpropanoate
B025	Benzyl isovalerate	Benzyl isovalerianate; Benzyl isopentanoate; Benzyl 3-methyl butyrate; Benzyl 3-methylbutanoate
B026	Benzyl mercaptan	Benzylthiol; Benzenemethanethiol; Phenylmethanethiol; α -Mercaptotoluene; Benzyl hydrosulfide; Thiobenzyl alcohol; α -Toluenthiol; Benzylmercaptan
B027	Benzyl methyl sulfide	Methyl benzyl sulfide; α -(Methylthio)toluene; Methylthio methyl benzene
B028	Benzyl phenylacetate	Phenylacetic acid, benzyl ester; Benzyl α -toluate; Phenylmethyl phenylacetate; Benzyl-2-phenyl ethanoate
B029	Benzyl propionate *	Propionic acid, benzyl ester; Benzyl propanoate
B030	Benzyl salicylate	Salicylic acid, benzyl ester; Benzyl o-hydroxybenzoate; Benzyl 2-hydroxybenzoate; Phenylmethyl 2-hydroxybenzoate
B031	Benzyl trans-2-methyl-2-butenate	Benzyl tigate; Benzyl 2-methylcrotonate; Benzyl trans-2,3-dimethyl acrylate; Benzyl trans-2-methyl crotonate; Benzyl 2-methyl-trans-2-butenate
B032	3-Benzyl-4-heptanone	Benzyl dipropyl ketone; morellone; 1-Phenyl-2-ethyl-3-hexanone; morellone
B033	Biphenyl	Phenylbenzene, diphenyl
B034	Birch tar oil	

Order	General Name	Synonyms
B035	Bis(methylthio)methane	2,4-Dithiapentane; bis(methyl mercapto)methane; Formaldehyde dimethyl dithioacetal; Formaldehyde dimethyl mercaptal; Thioformaldehyde dimethyl acetal
B036	Bisabolene	1,4(8),12-Bisabolatriene; 1-Methyl-4-(1,5-dimethyl-1,4-hexadienyl)-1-cyclohexene; β -bisabolene; 1-Methyl-4-(5-methyl-1-methylene-4-hexenyl)-1-cyclohexene; γ -bisabolene; 1-Methyl-4-(1,5-dimethyl-4-hexenylidene)-1-cyclohexene; 1-Methyl-4-(1,5-dimethyl-1,4-hexadienyl)-1-cyclohexene
B037	Borneol	Baros; d-camphanol; 2-Hydroxycamphane; camphol; Endo-2-camphanol; Endo-2-bornanol; Endo-2-hydroxycamphane; 2-Hydroxybornane; 1,7,7-Trimethylbicyclo(2,2,1)heptan-2-ol; 2-Bornanol; Borneo camphor; Bornyl alcohol; 2-Camphanol; Baros camphor
B038	Bornyl acetate	Borneol acetate; 2-Camphanyl acetate; l-Bornyl acetate; d-bornyl acetate; Bornyl acetic ether; Bornyl ethanoate; endo-2-bornyl acetate
B039	L-Bornyl acetate	(1S-endo)-1,7-Trimethylbicyclo[2.2.1]heptan-2-ol acetate; Bicycol[2.2.1]heptan-2-ol, 1,7,7-trimethyl-, acetate, (1S,2R,4S)-; (-)-Bornyl acetate
B040	Bornyl butyrate	Bornyl butanoate; Butanoic acid,1,7,7-trimethylbicyclo[2.2.1]hept-2-yl ester endo; Butyric acid, 2-bornyl ester
B041	Bornyl formate	Borneol formate; d-Bornyl formate; Endo-2-bornanyl formate; 2-Camphanyl formate; l-Bornyl formate; Bornyl methanoate
B042	Bornyl isovalerate (endo-)	Bornyval; Bornyl isovalerianate; Bornyl-3-methylbutanoate; Bornyval; Bornyl 3-Methylpentanoate; Bornyl 3-methylbutyrate; Bornyl isopentanoate
B043	Bornyl valerate	Bornyl valerianate; Bornyl n-pentanoate; Bicyclo[2.2.1]heptan-2-ol, 1,7,7-trimethyl; Endo-bornyl n-pentanoate; Endo-2-bornyl valerate; Endo-2-camphanyl valerate; Bornyl pentanoate

Order	General Name	Synonyms
B044	β -Bourbonene	
B045	Butan-2-ol	2-Butanol; 2-Hydroxybutane; Butylene hydrate; Methyl Ethyl carbinol; sec-Butyl alcohol
B046	Butan-3-one-2-yl butanoate	1-Methyl-2-oxopropyl butyrate; sec-Butan-3-onyl butyrate; Acetoxy butyrate
B047	2,3-Butanedithiol	2,3-Dimercaptobutane
B048	1,2-Butanedithiol	1,2-Dimercaptobutane
B049	1,3-Butanedithiol	1,3-Dimercaptobutane
B050	2-keto-4-Butanethiol	4-Mercapto-2-butanone; 4- Mercaptobutan-2-one
B051	1-Butanethiol	<i>n</i> -Butanethiol; <i>n</i> -Butyl mercaptan; Butyl mercaptan
B052	2-Butanone	Methyl ethyl ketone; Mek; Ketone C-4; Ethyl methyl ketone;
B053	(1-Buten-1-yl) methyl sulfide	But-1-enyl methyl sulphide; 1-Butenyl methyl sulfide
B054	Butter acids	
B055	Butter esters	
B056	Butyl 10-undecenoate	Butyl 10-hendecenoate; Butyl undecylenoate; Butylundec-10-enoate
B057	N-Butyl 2-methylbutyrate	Butyl 2-methylbutyrate; Butyl-2-methylbutanoate
B058	Butyl acetate *	Butyl ethanoate; n-butyl acetate
B059	Butyl acetoacetate	Butyl 3-ketobutyrate; Butyl 3-ketobutanoate; Butyl- β -ketobutyrate; Butyl 3-oxobutanoate, Butyl β -ketobutanoate
B060	Butyl alcohol	Propyl carbinol; 1-Butanol; n-Butyl alcohol, butan-1-ol; Butan-1-ol; Hydroxybutane

Order	General Name	Synonyms
B061	Butyl anthranilate	Butyl-2- aminobenzoate; Butyl o-aminobenzoate; Nibutyl 2-aminobenzoate
B062	Butyl butyrate *	n-butyl n-Butanoate; Butyl butanoate
B063	Butyl butyryllactate	Butyl-O-butyryllactate; Lactic acid, butyl ester, butyrate; Butyl 2-butyryloxypropanoate, Butyl butyrolactate; 2-butoxy-1-methyl-2-oxoethyl butyrate; Butyl- α -butyroxyl propionate; Butyl 2-(propylcarboxyl) propanoate
B064	Butyl cinnamate	n-Butyl phenylacrylate; Cinnamic acid, butyl ester; Butyl β -phenyl acrylate; Butyl 3-phenyl propenoate; Butyl 3-phenylpropenoate
B065	Butyl dec-2-enoate	Butyl 2-decenoate
B066	Butyl ethyl disulfide	1-Ethylbisulfanybutane, 3,4-Dithiooctane
B067	sec-Butyl ethyl ether	2-Butyl ethyl ether (sec-); 2- Butyl ethyl ether; Ether, sec-butyl ethyl
B068	Butyl ethyl malonate	Ethyl butyl malonate, Butyl ethyl propanedioate
B069	Butyl formate	Butyl methanoate; n-Butyl methanoate
B070	Butyl heptanoate	Butyl heptoate; butyl heptylate; n-Butyl heptoate; n-Butyl heptyrate; n-Butyl oenanthate; Butyl oenanthate
B071	Butyl hexanoate	Butyl caproate; Butyl carpronate; Butyl hexylate; n-Butyl hexanoate
B072	Butyl isobutyrate	Butyl 2-methylpropanoate; n-Butyl 2-methyl propanoate; Butyl-2-methylpropionate
B073	Butyl isothiocyanate	Isothiocyanic acid, butyl ester; 1-Isothiocyanatobutane; n-Butyl isothiocyanate; 4-Isothiocyanato-but-1-ene
B074	Butyl isovalerate	Butyl 3-methylbutanoate; Butyl isopentanoate; Butyl isovalerianate
B075	Butyl lactate	Butyl 2-hydroxypropanoate; Butyl α -hydroxypropionate; Butyl hydroxypropanoate

Order	General Name	Synonyms
B076	Butyl laurate	n-Butyl dodecanoate; Butyl dodecanoate; Butyl laurate; Butyl dodecylate
B077	Butyl levulinate	Butyl acetylpropionate; Butyl 4-ketovalerate; Butyl γ -butyrolactone; Butyl 4-oxopentanoate; Butyl 4-oxovalerate; n-Butyl acetopropionate; n-Butyl γ -ketovallerate; n-Butyl levulinate
B078	Butyl phenylacetate	Butyl α -toluate
B079	3-n-Butyl phthalide	3-Butylphthalide
B080	Butyl propionate	Butyl propanoate; n-Butyl propanoate
B081	Butyl salicylate	Butyl (2-hydroxyphenyl) formate; Benzoic acid; 2-hydroxy-; Butyl ester; n-Butyl o-hydroxybenzoate; n-Butyl salicylate; Butyl 2-hydroxybenzoate; Butyl (2-hydroxy-phenyl)-methanoate
B082	Butyl stearate	Butyl octadecanoate; Butyl octadecylate
B083	Butyl sulfide	Butylthiobutane; n-butylt sulfide; 1-1'-Thiobisbutane; Dibutyl sulfide; n-Butyl sulfide; Butylsulfide; Di-n-butyl sulphide
B084	Butyl valerate	n-Butylpentanoate; n-Butyl-n-valerianate; Butyl valerianate
B085	2-(2-Butyl)-4,5-dimethyl-3-thiazoline	2-(sec-Butyl)-4,5-dimethyl-3-thiazoline; 2,5-Dihydro-4,5-dimethyl-2-(1-methylpropyl)- thiazole; 2-(1-Methylpropyl)-4,5-dimethyl-3-thiazoline; 2,5-Dihydro-4,5-dimethyl-2-but- 2-yl thiazole
B086	2-(sec-Butyl)cyclohexanone	ortho-sec-Butylcyclohexanone; Freskomenthe; 2-(1-Methylpropyl)-cyclohexanone; 2-But-2-ylcyclohexanone
B087	2-Butyl-2-butenal	2-Ethylidene hexanal; 2- Ethylidinehexanal
B088	2-Butyl-5(6-keto-1,4)-dioxane	5(or 6)-Butyl-1,4-dioxane-2-one 1,4-Dioxan-2-one; 5(or 6)-Butyl-1

Order	General Name	Synonyms
B089	Butylamine	1-Aminobutane; n-Butylamine
B090	sec-Butylamine	(+/-)-2-Aminobutane; (+/-)-2-Butanamine; (+/-)-2-Butylamine; (+/-)-sec-Butylamine; (RS)-sec-Butylamine; 1-Methylpropanamine; 1-Methylpropylamine; 2-Aminobutane; 2-Butylamine; Butafume; Butan-2-ylamine; dl-2-Butylamine; DL-sec-Butylamine; Tutane; But-2-ylamine
B091	α -Butylcinnamaldehyde	2-Benzylidene hexanal; Butyl cinnamic aldehyde; α -Butyl- β -phenylacrolein
B092	2-Butylfuran	
B093	3-Butylidenephthalide	Liguisticum lactone
B094	Butyraldehyde	Butyl aldehyde; Butanal; Butyric aldehyde; 1-Aminobutane; m-Butylamine ; n-Butyraldehyde; Butyric aldehyde; n-Butanal; Butan-1-al; n-Butyl aldehyde
B095	Butyramide	Butyramide; Butanimidic acid; n-Butylamide; Butanamide
B096	Butyric acid *	n-Butyric acid; Butanoic acid; Ethylacetic acid; 1-Propanecarboxylic acid
B097	2-Butyrylfuran	1-(2-Furyl)-1-butanone; 2-Furyl propyl ketone; Furyl n-propyl ketone
B098	sec-Butyl acetate	Acetic acid, sec-butyl ester; sec-Butyl alcohol acetate; Acetic acid 2-butoxy ester; dl-sec-Butyl acetate; sec-Butyl ethanoate; Acetate de butyle secondaire; 1-Methylpropyl acetate; 1-Methylpropyl ethanoate; 2-Butanol acetate;2-Butyl acetate;Acetic acid, 1-methylpropyl este
B099	Butane-1,3-diol	β -Butylene glycol; Methyltrimethylene glycol; 1-Methyl-1,3-propanediol; 1,3-Butylene glycol; 1,3-Dihydroxybutane; 1,3-Butandiol; 1,3-Butylenglykol; 1,3-Butanodiol;Butanediol,1,3-;1,3-Butanediol

Order	General Name	Synonyms
B100	2-Butoxyethan-1-ol	Ethanol, 2-butoxy-; β -Butoxyethanol; Butyl cellosolve; Butyl glycol; Butyl oxitol; Ethylene glycol butyl ether; Ethylene glycol monobutyl ether; Glycol butyl ether; Glycol monobutyl ether; Monobutyl glycol ether; O-Butyl ethylene glycol; 2-Butoxy-1-ethanol; 2-Butoxyethanol; 3-Oxa-1-heptanol; Butyl 2-hydroxyethyl ether; 2-Hydroxyethyl n-butyl ether; n-Butoxyethanol; 2-n-Butoxyethanol; Ethylene glycol mono-n-butyl ether; Butoxyethanol; Butylglycol; Ethylene glycol n-butyl ether; Monobutyl ether of ethylene glycol; Butyl monoether glycol; 2-butoxyethanol ; 2-n-Butoxy-1-ethanol
B101	Butyl benzoate	n-Butyl benzoate; Benzoic acid n-butyl ester; Butyl ester of benzoic acid; Benzoic acid, butyl ester
B102	β -Bisabolene	Cyclohexene, 1-methyl-4-(5-methyl-1-methylene-4-hexenyl)-, (S)-; 1,5-Heptadiene, 6-methyl-2-(4-methyl-3-cyclohexen-1-yl)-, (S)-(-)-; l- β -Bisabolene; (+,-)- β -Bisabolene; 1-Methyl-4-(5-methyl-1-methylene-4-hexenyl)-1-cyclohexene; (-)- β -bisabolene; 1-Methyl-4-(5-methyl-1-methylene-4-hexenyl)-(S)-cyclohexene
B103	Butane-2-thiol	sec-Butyl thioalcohol; sec-Butanethiol; sec-Butyl mercaptan; sec-Butyl thiol; Secondary butylmercaptan; 1-Methyl-1-propanethiol; 2-Butyl mercaptan; 2-Mercaptobutane; Sec-butyl hydrosulfide; 2-Butanethiol
B104	Butane-2,3-diol	Dimethylethylene glycol; 2,3-Butylene glycol; 2,3-Dihydroxybutane; D-2,3-Butane diol; 2,3-Butanediol; 2,3-Butandiol; 2,3-butanodiol
B105	Bisabola-1,12-dien-8-ol	3-Cyclohexene-1-methanol, α ,4-dimethyl- α -(4-methyl-3-pentenyl)-, (R*,R*); 5-Hepten-2-ol, 6-methyl-2-(4-methyl-3-cyclohexen-1-yl)-; Bisabolol; α ,4-Dimethyl- α -(4-methyl-3-pentenyl)-3-cyclohexene-1-methanol; 6-Methyl-2-(4-methyl-3-cyclohexen-1-yl)-5-hepten-2-ol; (R*,R*)- α ,4-Dimethyl- α -(4-methyl-3-pentenyl)-3-cyclohexene-1-methanol; (R*,R*)- α ,4-Dimethyl- α -(4-methyl-3-pentenyl)cyclohex-3-ene-1-methanol; Camilol; Dragosantol; Hydagen B; α -Bisabalol; α -bisabolool

Order	General Name	Synonyms
B106	Benzyl methyl ether	Ether, benzyl methyl; α -Methoxytoluene; Methyl benzyl ether; Methoxymethylbenzene; α -Methylbenzyl ether; Benzene, (methoxymethyl)-
B107	Butyl 2-furoate	2-Furoic acid, butyl ester
B108	sec-Butyl formate	Formic acid, 1-methylpropyl ester; Formic acid, sec-butyl ester; sec-Butyl methanoate; s-Butyl formate
B109	Butyl octanoate	Caprylic acid n-butyl ester; n-Caprylic acid n-butyl ester; Octanoic acid, butyl ester; n-Butylcaprylate; n-Butyl n-octanoate; n-Butyl octanoate; Butyl caprylate
B110	Butyl but-2-enoate	
B111	Butyl methyl ketone	n-Butyl methyl ketone; Hexan-2-one; Methyl butyl ketone; Methyl n-butyl ketone; 2-Oxohexane; Hexanone-2; Ketone, butyl methyl; 2-Hexanone
B112	But-3-en-2-ol	Methyl vinylcarbinol; 1-Buten-3-ol; 1-Methyl-2-propenol; 3-Butene-2-ol; 3-Hydroxy-1-butene; Propenol, 1-methyl; 3-Buten-2-ol
B113	Benzyl isothiocyanate	Isothiocyanic acid, benzyl ester; Benzyl mustard oil; Toluene, α -isothiocyanato-; (Isothiocyanatomethyl)benzene; Benzene, (isothiocyanatomethyl)-
B114	Benzaldehyde diethyl acetal	Benzene, (diethoxymethyl)-; Toluene, α,α -diethoxy-; Diethoxymethyl)benzene
B115	sec-Butyl butyrate	Butyric acid, sec-butyl ester; Butanoic acid, 2-butyl ester; Butanoic acid, 1-methylpropyl ester
B116	3-Butenyl isothiocyanate	1-Butene, 4-isothiocyanato-; Isothiocyanic acid, 3-butenyl ester; 4-Isothiocyanato-1-butene; 1-butene 4-isothiocyanate
B117	Butanal diethyl acetal	Butyraldehyde, diethyl acetal; Butylaldehyde diethyl acetal; 1,1-Diethoxybutane; n-Butyraldehyde diethyl acetal

Order	General Name	Synonyms
B118	sec-Butyl Isothiocyanate	Butane, 2-isothiocyanato-; Isothiocyanic acid, sec-butyl ester; 2-Isothiocyanatobutane;2-Butyl isothiocyanate
B119	Butyl 2-methylbut-2(cis)-enoate	Butyl angelate
B120	Benzyl valerate	Valeric acid, benzyl ester; Benzylvaleryl; Benzyl pentanoate;Benzyl valerianate; Benzyl N-valerate; Phenylmethyl (benzyl) valerate; Phenylmethyl pentanoate;Pentanoic acid, phenylmethyl ester
B121	Butyl hex-2-enoate	
B122	Bisabola-1,8,12-triene	
B123	sec-Butyl lactate	Lactic acid, sec-butyl ester
B124	Butyl deca-2,4-dienoate	
B125	Butyl decanoate	n-Capric acid n-butyl ester; Decanoic acid, butyl ester; Butyl caprate; n-Butyl n-decanoate; n-butyl decanoate
B126	Butyl nonanoate	n-butyl nonanoate;Nonanoic acid, butyl ester
B127	Bis(1-mercaptopropyl)sulfide	Propanethiol, 1,1'-thiobis-
B128	Benzyl octyl ether	
B129	Benzyl 2-methylbutyrate	Benzyl 2-methylbutanoate;Butanoic acid, 2-methyl-, phenylmethyl ester
B130	1-Butoxy-1-ethoxyethane	Butane, 1-(1-ethoxyethoxy)-;1-(1-Ethoxyethoxy)butane
B131	Butyl oct-2-enoate	2-Octenoic acid, butyl ester
B132	Benzyl crotonate	
B133	1-Butoxy-1-(2-methylbutoxy)ethane	
B134	Butyl hex-3-enoate	Butyl trans-3-hexenoate

Order	General Name	Synonyms
B135	1-Butoxy-1-isopentyloxyethane	
B136	(E)-3-Benzo[1,3]dioxol-5-yl-N,N-diphenyl-2-propenamide	(2E)-3-(1,3-Benzodioxol-5-yl)-N,N-diphenylprop-2-enamide
B137	(E)-N-[2-(1,3-Benzodioxol-5-yl)ethyl]-3-(3,4-dimethoxyphenyl)prop-2-enamide	N-(Adamantane-1-yl)-1,3-benzodioxole-5-acrylamide
B138	2-(3-Benzyloxypropyl)pyridine	2-[3-(Phenylmethoxy)propyl]-pyridine
B139	alpha-Bisabolol	Levomenol; Kamillosan; Bisabola-1,12-dien-8-ol
B140	3- and 4- butyl-2- thiophenecarboxyaldehyde (mixture)	Mixture of 3- and 4- butyl-2- thiophenecarboxyaldehyde
B141	(E)-N-[2-(1,3-Benzodioxol-5-yl)ethyl]-3-(3,4-dimethoxyphenyl)prop-2-enamide	Rubescenamine; (2E)-N-[2-(1,3-benzodioxol-5-yl)ethyl]-3-(3,4-dimethoxyphenyl)prop-2-enamide
B142	(±)-Bicyclo[2.2.1]hept-5-ene-2-carboxylic acid, ethyl ester	(±)-Ethyl bicyclo[2.2.1]hept-5-ene-2-carboxylate; (±)-5-Norbornene-2-carboxylic acid, ethyl ester
B143	Butyl 2-naphthyl ether	beta-Naphthol butyl ether; 2-Butoxynaphthalene
C001	delta-Cadinene	α-, β-, γ, epsilon-Cadiene
C002	Camphene	3,3-Dimethyl-2-methylene norcamphane; 2,2-Dimethyl-3-methylene norbornane

Order	General Name	Synonyms
C003	Campholene acetate	α -Campholene acetate; 1-Acetoxy-2-(2,2,3-trimethyl-3-cyclopentanyl)ethane; 3-Cyclopentene-; -ethanol; 2,2,3-Trimethyl-, acetate; 2-(2,2,3-Trimethyl-3- cyclopentenyl)ethyl acetate
C004	α -Campholenic alcohol	α -Campholenol; 3-Cyclopentene-1-ethanol; 2,2,3-Trimethyl-; 2-(2,2,3-trimethyl)-3- cyclopentene-1-ethanol; 2-(2,2,3-Trimethylcyclopent-3-enyl)ethanol; 2-(2,3,3-Trimethyl- cyclopent-3-en-1-yl)ethanol
C005	d-Camphor	Gum camphor; Formosa camphor; 2-Camphanone; 2-bornanone; 2-Keto-1,7,7-trimethylnorcamphane; 1,7,7-Trimethylbicyclo (2.2.1) 2-heptanone; Laurel camphor; d-2-Bornanone; d-2-Camphanone
C006	Capsaicin	n-(4-Hydroxy-3-methoxybenzyl)-8-methyl-6-nonenamide; trans-8-Methyl-n-vanillyl-6-nonenamide; Isodecenoic acid vanillylamide; 8-Methylnon-6-enoyl 4-hydroxy-3-methoxybenzylamide
C007	delta-3-Carene	3-Carene; Isodiprene; d-3-Carene; Car-3-ene; 4,7,7-Trimethyl-3-norcarene; 3,7,7-Trimethylbicyclo[4,1,0]hept-3-ene
C008	Carvacrol	Cymophenol; Thymol(iso); Propyl iso o-cresol; p-Cymene-2-ol; 2-p-Cymenol; 2-Hydroxy-p-cymene; Isopropyl-o-cresol; Isothymol; 2-Methyl-5-isopropyl phenol; 2-Methyl-5-(1-methylethyl)phenol, Cymenphenol; 2-Hydroxy-p-cymenol
C009	Carvacryl ethyl ether	Ethyl carvacrol; 2-Ethoxy-p-cymene; Ethyl carvacryl ether
C010	Carveol	<i>p</i> -Mentha-6,8-dien-2-ol; 1-Methyl-4-isopropenyl-6-cyclohexen-2-ol
C011	4-Carvomethenol	Terpineol; 4-Terpinenol; 1-p-Menthen-4-ol; 1-Methyl-4-isopropyl-1-cyclohexen-4-ol; Origanol
C012	Carvone	Carvol; 6,8(9)- <i>p</i> -Menthadien-2-one; 1-menthyl-4-isopropenyl-6-cyclohexen-2-one
C013	d-Carvone	<i>p</i> -Mentha-6,8-dien-2-one; Dextro-carvone; (+)-Carvone

Order	General Name	Synonyms
C014	l-Carvone	p-Mentha-6,8-dien-2-one; Laevo-carvone; (-)-Carvone; p-Mentha-6,8-dien-2-one
C015	cis-Carvone oxide	1,6-Epoxy-p-menth-8-en-2-one.
C016	Carvone-5,6-oxide	7-Oxabicyclo[4.1.0]heptan-2-one, 1-methyl-4-(1-methylethenyl)-(1S,4R,6S)-; 1,6-Epoxy-p-menth-8-en-2-one
C017	Carvyl acetate	p-Mentha-6,8-dien-2-yl acetate; Carveyl acetate
C018	Carvyl propionate	l-Carveol propionate; 1-p-Mentha-6,8-dien-2-yl propionate
C019	β -Caryophyllene	2-Methylene-6,10,10-trimethylbicyclo (7.2.0) undec-5-ene; Caryophyllene
C020	β -Caryophyllene alcohol	Isocaryophyllene
C021	Caryophyllene alcohol acetate	Caryophyllene acetate
C022	β -Caryophyllene oxide	Caryophyllene epoxide; 4-12,12-Trimethyl-9-methylene-5-oxatricyclo[8.2.0.04, 6] dodecane
C023	Cedarwood oil alcohols	
C024	Cedarwood oil terpenes	
C025	1,4-Cineole	1,4-Epoxy-p-menthane
C026	Cinnamaldehyde *	Cinnamal; Cinnamic aldehyde; β -Phenylacrolein; 3-Phenylpropenal; Zimtaldehyde; Cassiaaldehyde; Benzylidene acetaldehyde; Phenylacrolein
C027	Cinnamaldehyde ethylene glycol acetal	Cinnamic aldehyde ethylene glycol acetal; Cinncloval; 2-Styryl-1,3-dioxolane; 2-styryl- <i>m</i> -dioxolane

Order	General Name	Synonyms
C028	Cinnamic acid *	3-Phenylacrylic acid; benzylideneacetic acid; Benzenepropenoic acid; Cinnamylic acid; β -Phenylacrylic acid; 3-Phenylpropenoic acid; 2-Phenyl-2-propenoic acid; Benzenepropenoic acid; tert- β -Phenylacrylic acid; 3-Phenyl-2-propenoic acid
C029	Cinnamyl acetate *	3-Phenyl-2-propen-1-yl acetate; 3-Phenylallyl acetate
C030	Cinnamyl alcohol *	Zimtalcohol; Cinnamic alcohol; γ -Phenylallyl alcohol; 3-Phenyl-2-propen-1-ol; styryl carbinol
C031	Cinnamyl benzoate	
C032	Cinnamyl butyrate	3-Phenyl-2-propen-1-yl butanoate; Butyric acid, 3-Phenyl-2-propen-1-yl ester; 3-Phenylallyl butyrate; Phenyl propenyl-n-butyrate
C033	Cinnamyl cinnamate	3-Phenyl-2-propen-1-yl 3-phenylpropenoate; 3-Phenylallyl cinnamate; Cinnamyl β -phenyl acrylate; Cinnamyl 3-phenyl propenoate; Phenylallyl cinnamate; Styracin
C034	Cinnamyl formate	3-Phenyl -2-propen-1-yl formate; 3-Phenylallyl formate; Cinnamyl methanoate
C035	Cinnamyl isobutyrate	Cinnamyl 2-methylpropanoate; 3-Phenyl-2-propen-1-yl isobutyrate; 3-Phenyl-2-propen-1-yl 2-methylpropanoate; Cinnamyl 2-methylpropanoate
C036	Cinnamyl isovalerate	3-Phenylallyl 3-methylbutanoate; 3-Phenyl-2-propen-1-yl 3-methylbutanoate; Cinnamyl 3-methylbutanoate; Ethyl 4-hydroxy-3-methoxybenzoate; 3-Phenylallyl isovalerate; Cinnamyl-3-methylbutyrate; Cinnamyl isovalerianate
C037	Cinnamyl phenylacetate	3-Phenyl-2-propen-1-yl phenylacetate; 3-Phenylallyl phenylacetate; Cinnamyl α -toluate
C038	Cinnamyl propionate	3-Phenyl-2-propen-1-yl propionate; 3-Phenylallyl propionate; γ -Phenylallyl propionate; 3-Phenyl-2-propenyl propanoate

Order	General Name	Synonyms
C039	Citral *	Geranial; 2- <i>trans</i> -3,7-Dimethyl-2,6-octadien-1-al; 2- <i>cis</i> -3,7-Ddimethyl-2,6-octadien-1-al; 2,6-Dimethyloctadien-2,6-al-8; Neral; Lemarome; Lemarome; 3,7-Dimethyl-2,6-octadienal; <i>trans</i> -3,7-Dimethylocta-2,6-dienal; <i>cis</i> - and <i>trans</i> -3,7-Dimethyl-2,6-octadienal
C040	Citral diethyl acetal	Citrathal; 1,1-Diethoxy-3,7-dimethyl-2,6-octadiene; 3,7-Dimethyl-2,6-octadienal diethylacetal
C041	Citral dimethyl acetal	Citrathal; 1,1-Dimethoxy-3,7-dimethyl-2,6-octadiene; 3,7-Dimethyl-2,6-octadienal dimethylacetal
C042	Citral propylene glycol acetal	
C043	Citronellal *	3,7-Dimethyl-6-octenal; 3,7-Dimethyl-6-octen-1-al; Rhodinal (dextro-rotatory form)
C044	Citronellol *	<i>d</i> -Citronellol or the <i>l</i> -form <i>sec</i> Rhodinol; 3,7-Dimethyl-6-octen-1-ol; (-)-3,7-Dimethyl-6-octen-1-ol
C045	Citronelloxyacetaldehyde.	
C046	Citronellyl acetate	3,7-Dimethyl-6-octen-1-yl ethanoate; Citronellyl ethanoate; 3,7-Dimethyl-6-octen-yl acetate
C047	Citronellyl anthranilate	6-Octen-1-ol, 3,7-dimethyl-, 2-aminobenzoate
C048	Citronellyl butyrate	3,7-Dimethyl-6-octen-yl butyrate; 3,7-Dimethyl-6-octen-1-yl butanoate; Citronellyl butanoate
C049	Citronellyl formate *	3,7-Dimethyl-6-octen-1-yl methanoate; Citronellyl methanoate; 3,7-Dimethyl-6-octen-1-yl formate
C050	Citronellyl isobutyrate	3,7-Dimethyl-6-octen-1-yl 2-methylpropanoate; 3,7-Dimethyl-6-octen-1-yl isobutyrate; Citronellyl 2-methylpropionate

Order	General Name	Synonyms
C051	Citronellyl oxycetaldehyde	Muget aldehyde; 6,10-Dimethyl-3-oxa-9-undecenal
C052	Citronellyl phenylacetate *	Citronellyl α -toluate; 3,7-Dimethyl-6-octen-1-yl phenylacetate
C053	Citronellyl propionate	3,7-Dimethyl-6-octen-1-yl propanoate; Citronellyl propanoate; 3,7-Dimethyl-6-octen-1-yl propionate
C054	Citronellyl valerate	Citronellyl valerianate; 3,7-Dimethyl-6-octen-1-yl pentanoate; Citronellyl pentanoate; 3,7-Dimethyl-6-octen-1-yl valerate
C055	p-Cresol	1-Methyl-4-hydroxybenzene; 1-Hydroxy-4-methylbenzene; p-Cresylic acid; 4-Methylphenol; 4-Cresol; p-Hydroxytoluene; p-Methyl phenol; 4-Hydroxytoluene
C056	o-Cresol	<i>o</i> -Cresylic acid; 2-Hydroxy-1-methylbenzene; 1-Hydroxy-2-methylbenzene; <i>o</i> -Hydroxytoluene; <i>o</i> -Methylphenol; 2-Methylphenol
C057	M-Cresol	<i>m</i> -Cresylic acid; 1-Hydroxy-3-methylbenzene; 3-Hydroxytoluene; 1-Methyl-3-hydroxybenzene; 3-Methylphenol; m-Methylphenol; 3-Hydroxytoluene
C058	Crotonic acid	(E)-2-Butenoic acid; trans-2-Butenoic acid; But-2-enoic acid (cis and trans)
C059	Cuminaldehyde	p-Propyl iso benzaldehyde; 4-Isopropylbenzenecarboxaldehyde; 4-(1-Methylethyl)-benzaldehyde; Cumaldehyde; Cuminal; Cuminic aldehyde; p-Isopropyl benzaldehyde; 4-Isopropylbenzaldehyde
C060	Cyclamen aldehyde	α -Methyl-p-isopropylhydrocinnamaldehyde; 2-Methyl-3-(p-isopropylphenyl) propionaldehyde; Cyclamal; Cyclaviol; Cyclosal; 3-(p-Cumenyl)-2-methylpropionaldehyde
C061	Cycloheptadec-9-en-1-one	9-Cycloheptadecen-1-one; civetone; α -trans-Civettone; Citvettone; cis-9-Cycloheptadecen-1-one
C062	Cyclohexanecarboxylic acid	Benzoic acid, Hexahydro; Carboxycyclohexane; Cyclohexylmethanoic acid, Hexahydrobenzoic acid

Order	General Name	Synonyms
C063	Cyclohexaneethyl acetate	Cyclohexylethyl acetate; Hexahydrophenethyl acetate; 2-Cyclohexylethyl acetate; Cyclohexane ethyl acetate; Ethylcyclohexyl acetate
C064	Cyclohexanone	Anon; Hexanon; Ketohexamethylene; Nadone; Pimelic ketone; Ketohexamethylene; pimelic ketone; Sextone; Nadone; Cyclohexyl ketone
C065	Cyclohexyl acetate	Cyclohexane acetate
C066	Cyclohexyl anthranilate	Cyclohexyl 2-aminobenzoate; Cyclohexyl <i>o</i> -aminobenzoate
C067	Cyclohexyl butyrate	Cyclohexyl butanoate
C068	Cyclohexyl cinnamate	Cyclohexyl β -phenylacrylate; cyclohexyl 3-phenylpropenoate; Cyclohexyl-3-phenyl prop-2-enoate
C069	Cyclohexyl formate	Formic acid, cyclohexyl ester
C070	Cyclohexyl isovalerate	Cyclohexyl isovalerianate; Cyclohexyl isopentanoate; Cyclohexyl 3-methylbutanoate; cyclohexyl 2-methylbutanoate
C071	Cyclohexyl propionate	
C072	Cyclohexylacetic acid	Hexahydrophenylacetic acid; Cyclohexaneacetic acid
C073	Cyclohexylmethyl pyrazine	2-Pyrazinyl cyclohexyl methyl; (2-Pyrazinylmethyl)cyclohexane; (Pyrazinylmethyl)- cyclohexane; 2-Pyrazinylcyclohexylmethane; 2-(cyclohexylmethyl)pyrazine
C074	Cycloionone	6,7,8,8a-Tetrahydro-2,5,5,8a-tetramethyl-5H-1-benzopyran
C075	Cyclopentanethiol	Cyclopentyl mercaptan
C076	Cyclopentanone	Adipic ketone; Dumasin; Ketocyclopentane; Ketopentamethylene; Ketocyclopentane; Ketopentamethylene; Adipic ketone; Dumasin

Order	General Name	Synonyms
C077	N-Cyclopropyl-trans-2-cis-6-nonadien-amide	N-Cyclopropyl-(E2,Z6)-nonadienamide; 2,6-Nonadienamide, N-cyclopropyl-, (2E,6Z)-
C078	p-Cymene	Cymol; Cymene; 4-Methyl-1-isopropylbenzene; p-Methylcumene; 1-Isopropyl-4-methylbenzene; p-Isopropyltoluene; 1-Methyl-4-isopropyl benzene; p-Methyl-isopropylbenzene; 4-Isopropyl-1-methylbenzene
C079	Cedrol	1H-3a,7-Methanoazulen-6-ol, octahydro-3,6,8,8-tetramethyl-, [3R-(3 α ,3a β ,6 α ,7 β ,8a α)]-; 8 β H-Cedran-8-ol; α -Cedrol; (+)-Cedrol; Cedran-8-ol
C080	Cyclopentanol	Cyclopentyl alcohol; Hydroxycyclopentane
C081	Cyclohexanol	Cyclohexyl alcohol; Adronal; Adronol; Anol; Hexahydrophenol; Hexalin; Hydroxycyclohexane; Naxol; Phenol, hexahydro-; 1-Cyclohexanol; Cyclohexane, hydroxy-; Hydralin; Hydrophenol
C082	α -Cedrene	1H-3a,7-Methanoazulene, 2,3,4,7,8,8a-hexahydro-3,6,8,8-tetramethyl-, [3r-(3 α ,3a β ,7 β ,8a α)]-; Cedr-8-ene
C083	cis-Carvyl acetate	2-Cyclohexen-1-ol, 2-methyl-5-(1-methylethenyl)-, acetate, cis-; p-Mentha-6,8-dien-2-ol, acetate, cis-; Carvyl acetate Z; 5-Isopropenyl-2-methyl-2-cyclohexen-1-yl acetate; Z-carvyl acetate; cis-2-Methyl-5-(1-methylethenyl)-2-cyclohexen-1-yl acetate
C084	Coumane	1a,7b-dihydrocyclopropa[c]chromen-2(1H)-one; Cyclopropylcoumarin
C085	Carvacryl methyl ether	Carvacrol methyl ether; methyl carvacrol
C086	Carvacryl acetate	
C087	Citronellyl hexanoate	

Order	General Name	Synonyms
C088	β-Cubebene	1H-Cyclopenta[1,3]cyclopropa[1,2]benzene, octahydro-7-methyl-3-methylene-4-(1-methylethyl)-, [3aα,3bβ,4β,7α,7aα*]-; 1H-Cyclopenta[1,3]cyclopropa[1,2]benzene, 2,3,3aα,3bα,4,5,6,7-octahydro-4α-isopropyl-7β-methyl-3-methylene-; 1H-Cyclopenta[1,3]cyclopropa[1,2]benzene, octahydro-7-methyl-3-methylene-4-(1-methylethyl)-, (3aα,3bα,4α,7β,7aR*); 4-Isopropyl-7-methyl-3-methyleneoctahydro-1H-cyclopenta[2,3]cyclopropa[1,2-a]benzene;β-Cuvebene
C089	8(14)-Cedrene	beta-Cedrene
C090	Citronellyl tiglate	2-Butenoic acid, 2-methyl-, 3,7-dimethyl-6-octenyl ester, (E)-; 3,7-Dimethyl-6-octenyl (2Z)-2-methyl-2-butenolate; E-Citronellyl tiglate
C091	Cedrenol	1H-3a,7-Methanoazulen-5-ol, octahydro-3,8,8-trimethyl-6-methylene-; Cedr-8(15)-en-9-ol
C092	2-Cedrene	
C093	Caryophyllene alcohol	4,4,8-trimethyltricyclo[6.3.1.02,5]dodecan-1-ol
C094	Citronellyl decanoate	
C095	Citronellyl dodecanoate	
C096	Cinnamaldehyde propyleneglycol acetal	4-methyl-2-(2-phenylethenyl)-1,3-dioxolane; 4-Methyl-2-styryl-1,3-dioxolane; 1,3-Dioxolane, 4-methyl-2-(2-phenylethenyl)-
C097	(±)-1-Cyclohexylethanol	(±)-Methylcyclohexylcarbinol; (±)-Cyclohexanemethanol
C098	L-Cysteine monohydrochloride*	L-Cysteine hydrochloride
C099	dl-Camphor	dl-1,7,7-Trimethylbicyclo[2.2.1]hepta-2-one;dl-2- Camphanone; dl-2-keto-1,7,7-Trimethylnorcamphane; (4S,R)-
C100	Cyclohexanone diethyl acetal	Cyclohexanone diethyl acetal; Rhumacetal; 1,1-Diethoxycyclohexane
C101	Cyclopropanecarboxylic acid (2-isopropyl-5-methyl-	N-(2-Isopropyl-5-methylcyclohexyl)cyclopropanecarboxamide

Order	General Name	Synonyms
C102	N-Cyclopropyl-5-methyl-2-isopropylcyclohexanecarboxamide	N-Cyclopropyl-5-methyl-2-(1-methylethyl)-cyclohexanecarboxamide;N-Cyclopropyl-5-methyl-2-(propan-2-yl)cyclohexanecarboximidicacid;Cyclohexanecarboxamide,N-cyclopropyl-5-methyl-2-(1-methylethyl)-
D001	Damascenone	1-(2,6,6,-Trimethyl-1,3-cyclohexadienyl)-2-buten-1-one; Floriffone; β -Damascone; 4-(2,6,6-Trimethylcyclohexa-1,3-
D002	β -Damascone	Damasione; Dihydro floriffone b; 4-(2,6,6-Trimethylcyclohex-1-enyl)but-2-en-4-one; 1-[(2,6,6)-Trimethyl-cyclohex-1-enyl]-but-2-en-1-one; tr-1-(2,6,6-Trimethyl-1-cyclohexen-1-yl)but-2-en-1-one
D003	delta-Damascone	2-Buten-1-one, 1-(2- β -6,6-trimethyl-3-cyclohexen-1- α -yl); 1-(2,6,6-Trimethyl-3- cyclohexen-1-yl)-2-butene-1-one
D004	α -Damascone	Dihydro floriffo; 2-Buten-1-one, 1-(2,6,6-trimethyl-2-cyclohexen-1-yl)-; 4-(2,6,6-Trimethyl-2-cyclohexenyl)-2-butene-4-one
D005	Trans- α -Damascone	Trans-1-2(2,6,6-trimethyl-2-cyclohexen-1-yl)but-2-en-1-one; 2-Buten-1-one, 1-(2,6,6-trimethyl-2-cyclohexen-1-yl)-, (2E)-
D006	2,4-Ddimethyl-5-acetylthiazole	2,4-Dimethyl-5-thiazoyl methyl ketone; 5-Acetyl-2,4-dimethylthiazole; 2,4-Dimethyl-5-acetylthiazole
D007	Dec-2-enal	3-Heptylacrolein; decenaldehyde; Decylenic aldehyde; n-Decene-2-al; trans-2-Decenal; Decenaldehyde; Decenaldehyde; 3-Heptylacrolein; Decylenic aldehyde; Dec-2-enal; 2-Decen-1-al
D008	(E,E)-2,4-Decadien-1-ol	trans,trans-2,4-Decadienol; 2,4-Decanoic acid; Deca-2,4-dien-1-ol
D009	2-trans,4-trans-Decadienal	Deca-2(trans),4(trans)-dienal; Heptenyl acrolein; 2,4-Decadienal; Deca-2,4-dienal; Heptenyl acrolein; 2,3-Decadienal

Order	General Name	Synonyms
D010	γ -Decalactone	4-Decanolide; 5-Hexyldihydro-2(3H)-furanone; 4-Hydroxydecanoic acid lactone; Deca-1,4-lactone; Decano-1,4-lactone; 4-Hydroxydecanoic acid, γ -lactone; 4-n-Hexyl-4-hydroxybutanoic acid lactone; γ -n-Decalactone; Decanolide-1,4; γ -n-Hexyl- γ -butyrolactone
D011	delta-Decalactone	5-Decanolide; 6-Pentyltetrahydro-2-pyrone; Deca-1,5-lactone; Decano-1,5-lactone; Decanolide-1,4; γ -n-Hexyl- γ -butyrolactone; 5-Hydroxy-decanoic acid, δ -Lactone; 5-n-Amyl-5-hydroxypentanoic acid lactone; Decanolide-1,5; Amyl-delta-valerolactone; delta-n-Amyl-delta-valerolactone
D012	Decanal *	Capraldehyde; Aldehyde C-10; Capric aldehyde; Caprinaldehyde; n-Decylaldehyde; Decylic aldehyde; Decyl aldehyde; n-Decanal
D013	Decanal dimethyl acetal	Aldehyde C-10 dimethyl acetal; Capraldehyde dimethyl acetal; Decylaldehyde dimethyl acetal; 1,1-Dimethoxy decane; 10,10-Dimethoxy decane
D014	Decanoic acid	Capric acid; Decylic acid
D015	1-Decanol *	Nonylcarbinol; Decylic alcohol; Alcohol C-10; capric alcohol; Decyl alcohol; Nonyl carbinol; Decan-1-ol; n-Decyl alcohol
D016	3-Decanol	Ethyl heptyl carbinol; Heptyl ethyl carbinol
D017	3-Decanone	Ethyl heptyl ketone
D018	2-trans-4-trans-7-cis-Decatrienal	(2E,4E,7Z)-Decatrienal
D019	3-Decen-2-one	Heptylidene acetone; Oenanthylidene acetone ; Dec-3-en-2-one; Enanthylidene acetone

Order	General Name	Synonyms
D020	1-Decen-3-ol	Heptyl ethenyl carbinol
D021	4-Decenal	(Z)-dec-4-en-1-al; Decenaldehyde, Dec-4-enal (cis)
D022	9-Decenal	
D023	9-Decenoic acid	Dec-9-enoic acid
D024	4-Decenoic acid	4-Decenoic acid
D025	5- and 6-Decenoic acid (mixture)	Dec-(5- and 6)-enoic acid; Decenoic acid; milk lactone
D026	cis-4-Decenyl acetate	4-Decen-1-ol, acetate, (Z)-dec-4-en-1-al
D027	Decyl acetate	Decyl ethanoate; Acetate C-10; Decanyl acetate; n-Decyl ethanoate; 1-Acetoxydecane; Acetic acid decyl ester; Decanol acetate
D028	Decyl butyrate	Decyl butanoate; n-Decyl butanoate; 1-Butyroxy decane
D029	Decyl propionate	Decyl propanoate; n-Decyl propanoate; 1-Propionoxy decane
D030	2-Decylfuran	Furan, 2-decyl-
D031	Dehydromenthofuro lactone	5,6-Dihydro-3,6-dimethylbenzofuran-2(4H)-one; 2(4H)-Benzofuranone, 5,6-dihydro-3,6-dimethyl-, (R)-; 3,6-Dimethyl-5,6-dihydro-2(4H)benzofuranone; 3,6-dimethyl-4,5-dihydro-6H-benzo(b) furan-2-one
D032	Dehydrodihydroionol	4-(2,6,6-Trimethyl-1,3-cyclohexadienyl)-3-butan-2-ol; 1,3-Cyclohexadiene-1-propanol, α -2,6,6-tetramethyl-; α -2,6,6-tetramethyl-1,3-cyclohexadien-1-propanol
D033	Dehydrodihydroionone	Dehydrodihydro- β -ionone; 3,4-Dehydrodihydro- β -ionone; 4-(2,6,6-Trimethylcyclohexadien-1-yl) 2-butanone; Dehydrodihydroionone

Order	General Name	Synonyms
D034	Dehydronootkatone	5,6-Dimethyl-8-isopropenyl bicyclo[4.4.0]-1,9-decadien-3-one; 4.β.H,5.α.-eremophila-1(10),8,11-trien-2-one; 8,9-didehydronootkatone
D035	1,2-Di((1'-ethoxy)-ethoxy)propane	3,5,8,10-Tetraoxadodecane, 4,6,9-trimethyl-; Acetaldehyde ethyl propylene glycol mixed acetal; 4,6,9-Trimethyl-3,5,8,10-tetraoxadodecane
D036	Di(butan-3-one-1-yl) sulfide	Di-(3-oxobutyl)sulfide; bis(Butan-3-one-1-yl) sulfide
D037	Diacetyl	Dimethyl diketone; Biacetyl; 2,3-Butanedione; 2,3-Diketobutane; Dimethylglyoxal; Dimethylglyoxal
D038	Diallyl polysulfides	Mixture of diallyl di-, tri-, tetra-, and pentasulfides; Polysulfides, diallyl; 2-Propenylpolysulfides; allyl polysulfides
D039	Diallyl trisulfide	Allyl trisulfide; Prop-2-enyl-trithio prop-2-ene; Allyl trisulphide
D040	Dibenzyl ether	Benzyl ether; Benzyl oxide
D041	Dibutyl sebacate	Butyl sebacate; Dibutyl decanedioate; Dibutyl 1,8-octanedicarboxylate; n-Butyl sebacate
D042	4,4-Dibutyl-γ-butyrolactone	4-Butyl-4-octanolide; 5,5-Dibutyldihydro-2(3H)-furanone; 4-Butyl-4-hydroxyoctanoic acid lactone; 4-Butyloctano-1,4-lactone; 4-Butyl-4-hydroxyoctanoic acid, γ-lactone; Dibutyl butyrolactone; 4,4-Dibutyl-4-hydroxy-butyric acid, γ-lactone
D043	Dicyclohexyl disulfide	Cyclohexyl disulfide; Disulfide, dicyclohexyl
D044	Diethyl disulfide	Disulfide, diethyl; Ethyl disulfide; 3,4-dithiahexane; Ethyl disulphide; Ethyldithioethane
D045	Diethyl malate	Diethyl 2-hydroxybutanedioate; d-Ethyl malate; Diethylhydroxysuccinate; Ethyl malate
D046	Diethyl malonate	Ethyl propanedioate; Ethyl methanedicarboxylate; Ethyl malonate; Malonic ester

Order	General Name	Synonyms
D047	Diethyl sebacate	Ehyl decanedioate; Diethyl decanedioate; Diethyl 1,8-octanedicarboxylate; Ethyl sebacate
D048	Diethyl succinate	Diethyl butanedioate; Diethyl ethanedicarboxylate; Ethyl succinate
D049	Diethyl sulfide	Ethyl sulfide; 1-1'-Thiobisethane; 3-Thiapentane; Diethylthioether; Ethyl monosulfide; Ethyl thioether; Ethyl thioethane; Thioethyl ether; Sulfodor; Ethane, 1,1-Thiobis-
D050	Diethyl tartrate	Diethyl 2,3-dihydroxybutanedioate; Diethyl 2,3-dihydroxysuccinate; ethyl tartrate
D051	Diethyl trisulfide	1-Ethyltrisulfanylethane, 3,4,5-Trithiaheptane
D052	Minture of 3,6-Diethyl-1,2,4,5-tetrathiane and 3,5-diethyl-1,2,4-trithiolane	1,2,4,5-Tetrathiane, 3,6-diethyl- and 1,2,4-trithiolane, 3,5-diethyl-1,2,4-trithiolane
D053	cis-trans-3,5-Diethyl-1,2,4-trithiolane	(+/-)-cis-and trans-3,5-Diethyl-1,2,4-trithiolane
D054	3,5-Diethyl-2-methylpyrazine	Pyrazine, 3,5-diethyl-2-methyl-pyrazine; 2-Methyl-3,5-diethyl-1,4-diazine; 2,6-Diethyl-3-methylpyrazine
D055	2,5-Diethyl-3-methylpyrazine	Pyrazine, 2,5-diethyl-3-methyl-pyrazine; 2,5-Diethyl-3-methyl-1,4-diazine
D056	2,3-Diethyl-5-methylpyrazine	2-Methyl-5,6-diethylpyrazine; 2,3-Diethyl-5-methyl-1,4-diazine
D057	2,3-Diethylpyrazine	2,3-Diethyl-1,4-diazine
D058	2,5-Diethyltetrahydrofuran	Tetrahydrofuran, 2,5-diethyl-; Furan, 2,5-diethyltetrahydro-;
D059	Difurfuryl ether	Furfuryl ether
D060	2,4-Difurfurylfuran	Furan, 2,4-bis(2-furanylmethyl)-
D061	6,7-Dihydro-2,3-dimethyl-5H-cyclopentapyrazine	5H-Cyclopentapyrazine, 6,7-dihydro-2,3-dimethyl; (5H)-2,3-dimethyl-6,7-dihydrocyclopenta(B)pyrazine

Order	General Name	Synonyms
D062	5,7-Dihydro-2-methylthieno(3,4-d)pyrimidine	5,7-Dihydro-2-methylthieno[3,4d]pyridine; Thieno(3,4d)pyrimidine, 5,7-dihydro-2-methyl
D063	4,5-Dihydro-3(2H)-thiophenone	Tetrahydrothiophen-3-one; 3-Tetrahydrothiophenone; 3-thiophanone, 3-thiophane; Dihydrothiophenone
D064	Dihydro- α -ionone	2-Butanone, 4-(2,6,6-trimethyl-2-cyclohexen-1-yl); 4-(2,6,6-trimethyl-2-cyclohexen-1-yl)butan-2-one
D065	Dihydro- β -ionol	1-Cyclohexene-1-propanol, α ,2,6,6-tetramethyl-; β -Dihydroionol; 4-(2,6,6-trimethyl-1-cyclohexenyl)butan-2-ol
D066	Dihydro- β -ionone	2-Butanone, 4-(2,6,6-trimethyl-1-cyclohexen-1-yl); 4-(2,6,6-Trimethyl-1-cyclohexenyl)buten-2-one
D067	Dihydrocarveol	8- <i>p</i> -Menthen-2-ol; 6-methyl-3-Isopropenylcyclohexanol; Tuberyl alcohol
D068	Dihydrocarvone	<i>p</i> -Menth-8-en-2-one; 3-Isopropenyl-6-methylcyclohexanone; <i>cis</i> -Dihydrocarvone; <i>cis</i> -l-Dihydrocarvone; 8- <i>p</i> -menthen-2-one; <i>cis</i> - <i>p</i> -Menthen-8(9)-one(2); 1-Methyl-4-isopropenyl cyclohexan-2-one; <i>Cis</i> -Dihydrocarvone; <i>cis</i> -Menthen- 8(9)-one(2)
D069	Dihydrocarvyl acetate	<i>p</i> -Menth-8(9)-em-2-yl acetate; Tuberyl acetate; 1-Methyl-4-isopropenylcyclohexan-2-yl acetate; Carhydrine; 8- <i>p</i> -Menthen-2-yl; <i>p</i> -Menth-8-(9)-en-2-yl acetate; 6-Methyl-3-isopropenyl cyclohexyl acetate; 6-Methyl-3-(1-methylvinyl)cyclohexyl acetate; Dihydrocarveyl acetate
D070	Dihydrocoumarin	1,2-Benzodihydropyrone; Hydrocoumarin; <i>o</i> -Hydroxydihydrocinnamic acid lactone; 3,4-Dihydro-2h-1-benzopyran-2-one; 2-Chromanone; meliotine; Benzodihydropyrone; 3,4-Dihydrocoumarin; Hydrocoumarin; Melilotic acid lactone; 2-Oxochroman

Order	General Name	Synonyms
D071	(+/-)Dihydrofarnesol	3,7,11-Trimethyl-6,10-dodecadien-1-ol, (+/-); 2,3-Dihydrofarnesol,(+/-)
D072	Dihydrojasmane	2-Pentyl-3-methyl-2-cyclopenten-1-one; 3-Methyl-2-pentylcyclopent-2-en-1-one; Dihydrojasmane; 3-Methyl-2-(n-pentanyl)-2-cyclopentene-1-one
D073	Dihydromintlactone	2(3H)-Benzofuranone, hexahydro-3,6-dimethyl; 3,6-Dimethylcyclohexylacetolactone; 2-(2-Hydroxy-4-methylcyclohexyl)propionic acid γ -lactone; (+/-)-Dihydromintlactone
D074	1,10-Dihydronootkatone	Dihydronootkatone;1,4,4a,5,6,7,8,8a-octahydro-4,4a-dimethyl-6-isopropenyl-2(1H)-naphthalenone
D075	2,5-Dihydroxy-1,4-dithiane	1,4-Dithiane-2,5-diol; Mercaptoacetaldehyde dimer; p-dithiane-2,5-diol
D076	Dihydroxyacetone	2-Propanone, 1,3-dihydroxy(monomer); 1,3-Dihydroxyacetone; α,α -Dihydroxyacetone(monomer); (Bis)hydroxymethylketone(monomer); Chromelin(monomer);1,4-Dioxan-2,5-dimethanol,2,5-dihydroxy-,trans(dimeric form)
D077	Dihydroxyacetophenone	1-(x,y-Dihydroxyphenyl) ethanone; dioxyacetophenone; 2,4-Dihydroxyacetophenone; 1-Phenyletanone, Dihydroxy derivative; Dihydroxyphenyl methyl ketone; 1-(dihydroxyphenyl)ethanone; 1-Ethanone
D078	2,4-Dihydroxybenzoic acid	β -Resorcylic acid; 4-carboxyresorcinol; β -Resorcinolic acid; p-Hydroxysalicylic acid
D079	Diisopentyl thiomalate	Butanedioic acid, nercapto-, bis(3-methylbutyl) ester; bis(3-Methylbutyl)- mercaptosuccinate
D080	Diisopropyl disulfide	Isopropyl disulfide; 2,5-Dimethyl-3,4-dithiahexane; bis(1-Methylethyl)disulfide; Disulfide, bis(1-methylethyl)

Order	General Name	Synonyms
D081	Diisopropyl trisulfide	Bis(1-methylethyl)trisulfide; 2,6-Dimethyl-3,4,5-trithiaheptane
D082	Dimercaptomethane	Methanedithiol
D083	3,4-Dimethoxy-1-vinylbenzene	3,4-Dimethoxystyrene; 1,2-Dimethoxy-4-vinylbenzene
D084	M-Dimethoxybenzene	1,3-Dimethoxybenzene; Dimethylresorcinol; Resorcinol dimethyl ether
D085	p-Dimethoxybenzene	Dimethylbenzyl carbonyl acetate; 1,4-Dimethoxybenzene; Dimethyl hydroquinone; Hydroquinone dimethyl ether; 4-Methoxyphenyl methyl ether
D086	1,2-Dimethoxybenzene	Veratrole; o-Dimethoxybenzene; Catechol dimethyl ether
D087	N1-(2,4-Dimethoxybenzyl)-N2-(2-(pyridin-2-yl)ethyl)oxalamide	Ethanediamide, N-[(2,4-dimethoxyphenyl)methyl]-N -(2-(2-pyridinyl)ethyl)-
D088	1,1-Dimethoxyethane	Acetaldehyde dimethyl acetal; Dimethyl acetal; Ethylidene dimethyl ether
D089	2,6-Dimethoxyphenol	2-Hydroxy-1,3-dimethoxybenzene; syringol; pyrogallol dimethyl ether; Pirogallol, 1,3-dimethyl ether; Syringol
D090	1,1-Dimethoxy-trans-2-hexene	1,1-Dimethoxy-E-2-hexene; 2-hexene, 1,1-dimethoxy-,(2E)-; 2-Hexene, 1,1-dimethoxy-, (E)-; (E)-2-Hexenal dimethyl acetal; trans-20-Hexenal dimethyl acetal
D091	2,4-Dimethyl anisole	1,3-Dimethyl-4-methoxybenzene; 2,4-Dimethyl-1-methoxybenzene; 1-Methoxy-2,4-dimethylbenzene; 4-methoxy-m-xylene
D092	Dimethyl anthranilate	Methyl N-methylantranilate; Dimethyl anthranilate; 2-Methylamino methyl benzoate; Methyl 2-Methylamonobenzoate; Methyl o-Methylaminobenzoate
D093	Dimethyl benzyl carbonyl butyrate	Benzyl dimethyl carbonyl butyrate; Dmbc butyrate; 2-Benzyl-2-propyl butyrate; 1,1-Dimethyl-2-phenethyl butyrate; 2-benzyl-2-propyl butyrate; DMBC butyrate; 2-Methyl-1-phenyl-2-propyl butyrate; α,α -Dimethylphenethyl butyrate

Order	General Name	Synonyms
D094	Dimethyl disulfide	Methyl disulfide; Methyl disulphide
D095	(+/-)-N,N-Dimethyl menthyl succinamide	Butanoic acid, 4-(Dimethylamino-4-oxo-, (1R,2S,5R)-5-methyl-2-(1-methylethyl)- cyclohexyl ester; Butanoic acid, 4-(dimethylamino)-4-oxo-, [1R-(1 α , 2 β , 5 α)]-5-methyl-2-(1-methylethyl)cyclohexyl ester
D096	Dimethyl methoxy furanone	2,5-Dimethyl-4-methoxy-3(2H)-furanone; 4-Methoxy-2,5-dimethyl-3(2H)-furanone; Furaneol methyl ether; Mesifurane; 4-Methoxy-2,5-dimethyl-3-furanone
D097	2,6-Dimethyl octanal	Isodecylaldehyde
D098	Dimethyl phenethyl carbonyl acetate	2-Methyl-4-phenyl-2-butyl acetate; 1,1-Dimethyl-3-phenylpropan-1-yl acetate; 1,1-Dimethyl-3-phenylpropyl acetate; Dimethyl phenethyl carbonyl acetate
D099	Dimethyl phenethyl carbonyl isobutyrate	2-Methyl-4-phenyl-2-butyl isobutyrate; 2-Methyl-4-phenyl-2-butyl 2-methylpropanoate; phenylethyl dimethyl carbonyl isobutyrate; 1,1-Dimethyl-3-phenylpropyl isobutyrate; Dimethyl phenethyl carbonyl isobutyrate
D100	Dimethyl succinate	Dimethyl butanedioate; Methyl succinate; Methyl butanedioate
D101	Dimethyl trisulfide	Methyl trisulfide; Methyl trithio methane; Methyl trisulphide
D102	2,6-(Dimethyl)thiophenol	Benzenethiol, 2,6-dimethyl-; 2,6-dimethylbenzenethiol; 2,5-xylenethiol
D103	3,5-Dimethyl-1,2,4-trithiolane	1,2,4-Trithiolane, 3,5-dimethyl-; 2,5-dimethyl-1,3,4-trithiolane; 3,5-dimethyl-1,2,4- trithiaclopentane
D104	3,4-Dimethyl-1,2-cyclo-pentadione	2-Hydroxy-3,4-dimethyl-2-cyclopenten-1-one

Order	General Name	Synonyms
D105	3,5-Dimethyl-1,2-cyclo-pentadione	
D106	3,7-Dimethyl-1,3,6,-octatriene	β -Ocimene; Ocimene; trans- β -ocimene; 1,3,6-octatriene, 3,7-dimethyl-
D107	3,5- and 3,6-Dimethyl-1,3-dimethyl-2-isobutylpyrazine	Pyrazine, 3,5-dimethyl-3-(2-methylpropyl)- and pyrazine, 3,6-dimethyl-3-(2-methylpropyl)-; 3,5-Dimethyl-3-(2-methylpropyl)-1,4-diazine and 3,6-dimethyl-3-(2-methylpropyl)-1,4-diazine
D108	2,4-Dimethyl-1,3-dioxolane	1,3-Dioxolane, 2,4-dimethyl-; Acetaldehyde cyclic propylene glycol acetal; Propylene acetal
D109	(E,R)-3,7-Dimethyl-1,5,7-octatrien-3-ol	3,7-Dimethylocta-1,5,7-trien-3-ol; Hotrienol; Dehydrolinalool; (E)-3,7-dimethyl-1,5,7-octatrien-3-ol
D110	2,6-Dimethyl-10-methylene-2,6,11-dodecatrienal	
D111	3,7-Dimethyl-1-octanol	3,7-Dimethylcotanol; Dihydrocitronellol; Tetrahydrogeraniol
D112	2,5-Dimethyl-2,5-dihydroxy-1,4-dithiane	2,5-Dihydroxy-2,5-dimethyl-1,4-dithiane; 2,5-Dimethyl-2,5-dihydroxy-p-dithiane
D113	3,7-Dimethyl-2,6-octadien-1-yl 2-ethylbutanoate	Geranyl 2-ethyl butyrate; trans-3,7-Dimethyl-2,6-octadien-1-yl 2-ethylbutanoate; 3,7-Dimethylocta-2,6-dienyl 2-ethylbutanoate
D114	2-(3,7-Dimethyl-2,6-octadienyl)cyclopentanone	(E)-2-(3,7-Dimethyl-2,6-octadienyl)cyclopentanone; Decenylcyclopentanone; Geranylcyclopentanone
D115	4,5-Dimethyl-2-ethyl-3-thiazoline	2-Ethyl-4,5-dimethyl-3-thiazoline; 2-Ethyl-2,5-dihydro-4,5-dimethylthiazole
D116	4,5-Dimethyl-2-isobutyl-3-thiazoline	2,5-Dihydro-4,5-dimethyl-2-(2-methylpropyl) thiazole; 2-Isobutyl-4,5-dimethyl-3-thiazoline; 4,5-Dimethyl-2-(2-methylpropyl)-3-thiazoline; 3-Thiazoline, 4,5-dimethyl-2-(2-methylpropyl)-

Order	General Name	Synonyms
D117	2,4-Dimethyl-2-pentenoic acid	
D118	2,5-Dimethyl-3(2H)-furanone	3(2H)-Furanone, 2,5-dimethyl-; 2,3-Dihydro-2,5-dimethyl-3-furanone; 2,5-Dimethyl-2,3-dihydrofuran-3-one; 2,5-Dimethyl-2H-furan-3-one
D119	(+/-)-trans- and cis-4,8-Dimethyl-3,7-nonadien-2-ol	(+/-)E- and Z-4,8-Dimethyl-3,7-nonadien-2-ol; 3,7-Nonadien-2-ol, 4,8-dimethyl- (E,Z)-
D120	(E) & (Z)-4,8-Dimethyl-3,7-nonadien-2-one	Citronone
D121	(+/-)-trans- and cis-4,8-Dimethyl-3,7-nonadien-2-yl acetate	(+/-)E- and Z-4,8-Dimethyl-3,7-nonadien-2-yl; Acetate; 3,7-Nonadien-2-ol, 4,8-dimethyl-, acetate (E,Z)-
D122	2,6-Dimethyl-3-[(2-methyl-3-furyl)thio]-4-heptanone	1,3-Diisopropylacetyl 2-methyl-3-furyl sulfide; 4-Heptanone, 2,6-dimethyl-3-[(2-methyl-3-furyl)thio]-; 3-((2-Methyl-3-furyl)thio)-2,6-dimethyl-4-heptanone
D123	2,5-Dimethyl-3-furan thioisovalerate	2,5-Dimethyl-3-(isopentylthio)furan; S-(2,5-Dimethyl-3-furyl) 3-methylbutanethioate; S-(2,5-dimethyl-3-furyl)thioisovalerate; 2,5-Dimethyl-3-thioisovaleryfuran
D124	2,5-Dimethyl-3-furanthiol	2,5-Dimethyl-3-furylmercaptan; 2,5-Dimethyl-3-mercaptofuran
D125	2,5-Dimethyl-3-furanthiol acetate	Ethanethioic acid, S-(2,5-dimethyl-3-furyl)ester; S-(2,5-Dimethyl-3-furyl)- ethanethioate; S-(2,5-Dimethylfuran-3-yl)ethanethioate; S-(2,5-Dimethylfuran-3-yl)thioacetate; Thioacetic acid S-(2,5-dimethylfuran-3-yl)ester; 2,5-Dimethyl-3-thioacetoxyfuran; 3-Thioacetyl-2,5-dimethylfuran; 3-Acetylthio-2,5-dimethylfuran; 3-(Acetylthio)-2,5-dimethylfuran

Order	General Name	Synonyms
D126	bis-(2,5-Dimethyl-3-furyl) disulfide	3,3(1)-Dithiobis(2,5-dimethylfuran); Furan, 3,3"-dithiolbis[2,5-dimethyl]-
D127	4,5-Dimethyl-3-hydroxy-2,5-dihydrofuran-2-one	3-Hydroxy-4,5-dimethyl-2(5H)-furanone; 3-Hydroxy-4,5-dimethylfuran-2(5H)-one; 2,3-Dimethyl-4-Hydroxy-2,5-dihydrofuran-5-one; 3-Hydroxy-4, 5-dimethyl-2(5)-furanone; 2-Hydroxy-3-methyl-2-penten-4-olide; Sugar lactone; 2-Hydroxy-3-methylpent-2-en-1,4-lactone
D128	2,5-Dimethyl-3-oxo-(2H)-fur-4-yl butyrate	Butanoic acid, 4,5-Dihydro-2,5-dimethyl-4-oxo-3-furanyl ester; 4-Butyroxyl-2,5-dimethyl-3(2H)-furanone
D129	2,5-Dimethyl-3-thiofuroylfuran	S-(2,5-Dimethyl-3-furyl)thio-2-furoate; 3-Furancarbothioic acid S-(2,5-dimethyl-3-furanyl) ester
D130	1,4-Dimethyl-4-acetyl-1-cyclohexene	1-(1,4-Dimethylcyclohex-3-en-1-yl)ethan-1-one; 1,4-Dimethylcyclohex-3-enyl methyl ketone
D131	2,5-Dimethyl-4-ethoxyfuran-3(2H)-one	3(2H)-Furanone, 4-ethoxy-2,5-dimethyl-; 2,3-Dihydro-2,5-dimethyl-4-ethoxy-3- furanone; 2,5-Dimethyl-2,3-dihydro-4-ethoxyfuran-3-one; 2,5-Dimethyl-4-ethoxy-2H- furan-3-one
D132	2,6-Dimethyl-4-heptanol	Di-isobutyl carbinol; 4-Hydroxy-2,6-dimethyl heptane; Di-isobutyl carbinol
D133	2,6-Dimethyl-4-heptanone	Di-isobutyl ketone; 4-Heptanone, 2,6-dimethyl; Isobutyl ketone; isovalerone; iso-Nonanone
D134	2,2-Dimethyl-5-(1-methylpropen-1-yl)tetrahydrofuran	Citroxide; Furan, tetrahydro-2,2-dimethyl-5-(1-methyl-1-propenyl)-; Ocimen quintoxide; Tetrahydrofuran, 2,2-dimethyl-5-(1-methyl-1-propenyl)-

Order	General Name	Synonyms
D135	6,10-Dimethyl-5,9-undecadien-2-one	2,6-Dimethyl-2,6-undecadien-10-one; Geranyl acetone; 5,9-Undecadien-2-one, 6,10-dimethyl-, (E); (E)-6,10-dimethylundeca-5,9-dien-2-one; α,β -Dihydropseudoionone
D136	2,6-Dimethyl-5-heptenal	2,6-Dimethylhept-5-1-al; 2,6-Dimethyl-2-hepten-7-al; Melonal
D137	2,4-Dimethyl-5-vinylthiazole	
D138	2,6-Dimethyl-6-hepten-1-ol	2,6-Dimethylhept-7-en-1-ol; α -Melonol
D139	3,7-Dimethyl-6-octenoic acid	Citronellic acid; Rhodinolic acid; Rhodinic acid
D140	(S)-3,7-Dimethyl-7-octen-1-ol	
D141	2,4-Dimethylacetophenone	Acetyl-m-xylene; Methyl 2,4-dimethylphenyl ketone; 1-(2,4-Dimethylphenyl)ethanone
D142	2,4-Dimethylbenzaldehyde	2,4-Xylylaldehyde; 1-Formyl-2,4-dimethylbenzene
D143	2,3-Dimethylbenzofuran	Benzofuran, 2,3-dimethyl-
D144	p- α -Dimethylbenzyl alcohol	p-Tolyl methyl carbinol; Methyl-p-tolyl carbinol; 1-p-Tolyl-1-ethanol; 4-(α -Hydroxyethyl)toluene; 4-Methyl- α -phenethyl alcohol; 1-(4-Methylphenyl)ethanol, 1-p-Tolyethanol; 1-(p-Tolyl)ethan-1-ol; 4-Toluene
D145	a,a-Dimethylbenzyl isobutyrate	Phenyldimethylcarbiny isobutyrate.
D146	(+/-)-trans- and cis-5-(2,2-Dimethylcyclopropyl)-3-methyl-2-pental	(+/-)E- and Z-5-(2,2-Dimethylcyclopropyl)-3-methyl-2-pental; 2-Pental, 5-(2,2-dimethylcyclopropyl)-3-methyl-(E,Z)-; Acitral
D147	4-(1,1-Dimethylethyl)phenol	p-Tert-butyl 4-tert-butylphenol; p-Tert-butylphenol, 4-Tert-butylphenol; p-Tert-butylphenol; 1-Hydroxy-4-tert-butylbenzene

Order	General Name	Synonyms
D148	2,5-Dimethylfuran	Furan, 2,5-dimethyl-
D149	2,6-Dimethyloctanal	Isodecanal; Decylaldehyde(ISO); 2,6-Dimethyl octanoic aldehyde; isoaldehyde C-10; isodecylaldehyde
D150	α,α -Dimethylphenethyl acetate	Dimethyl benzyl carbinyl acetate; 2-Benzyl-2-propylate; 1,1-Dimethyl-2-phenethyl acetate; Benzyl dimethylcarbinyl acetate; Benzylpropyl acetate; 2-Benzyl-2-propyl acetate; 2-Methyl-1-phenyl-2-propyl acetate
D151	α,α -Dimethylphenethyl alcohol	Dimethylbenzyl carbinol
D152	α,α -Dimethylphenethyl butyrate	Benzyl dimethylcarbinyl butyrate
D153	α,α -Dimethylphenethyl formate	Benzyl dimethylcarbinyl formate
D154	N,N-Dimethylphenethylamine	Benzenemethanamine, N,N- α -trimethyl-, (R)-; Benzylamine, N,N, α -trimethyl-, L-(+)-; (+)-(R)-N,N-Dimethyl- α -phenethylamine; (+)-N,N, α -Trimethylbenzylamine; (+)-N,N-Dimethyl- α -methylbenzylamine; (R)-(+) -N,N-Dimethyl-1-phenethylamine; (R)- α -Methylbenzyl dimethylamine; (R)-Dimethyl(1-phenylethyl)amine; (R)-N,N-Dimethyl-1-phenethylamine; (R)-[1-(Dimethylamino)ethyl]benzene
D155	α,α -Dimethylphenylethyl alcohol	2-Benzyl-2-propanol; 2-Hydroxy-2-methyl-1-phenylpropane; α,α -Dimethylphenethanol; Benzyl dimethyl carbinol; Dimethyl benzyl carbinol; 1,1-Dimethyl-2-phenylethanol; 2-Methyl-1-phenyl-propanol-2; 2-Methyl-1-phenylpropan-2-ol; 2-Benzyl-2-propanol; 2-Hydroxy-2-methyl-1-phenylpropanone
D156	α,α -Dimethylphenylethyl formate	2-Benzyl-2-propyl formate; 2-Methyl-1-phenyl-2-propyl formate; Benzyl dimethylcarbinyl formate; Dimethylbenzylcarbinyl formate; α,α -Dimethylphenethyl formate

Order	General Name	Synonyms
D157	2,3-Dimethylpyrazine	2,3-Dimethyl-1,4-diazine
D158	2,5-Dimethylpyrazine	2,5-Dimethylpiazine; 2,5-Dimethylparadiazine; 2,5-Dimethyl-1,4-diazine; glycoline
D159	2,6-Dimethylpyrazine	2,6-Dimethylparadiazine; 2,6-Dimethylpiazine; 2,6-Dimethyl-1,4-diazine; 2,6-Dimethyl-p-diazine
D160	2,6-Dimethylpyridine	2,6-Lutidine
D161	p- α -Dimethylstyrene	p-Propenyl iso benzene; 1-Isopropenyl-4-methylbenzene; p-Isopropenyl toluene; 1-Methyl-4-isopropenylbenzene; 2-p-Tolyl propene; 4- α -Dimethylstyrene; dehydro-p-cymene
D162	2,5-Dimethyltetrahydro-3-furyl thioacetate, cis and trans isomers	cis and trans-2,5-Dimethyltetrahydro-3-furyl thioacetate; Ethanethioic acid, S-(tetrahydro-2,5-dimethylfuryl)ester; S-(2,5-dimethyl)tetrahydrofuran-3-yl thioacetate
D163	2,5-Dimethyltetrahydrofuran-3-thiol, cis and trans isomers	cis & trans 2,5-Dimethyltetrahydrofuran-3-thiol; Tetrahydro-2,5-dimethylfuran-3-thiol
D164	4,5-Dimethylthiazole	
D165	2,5-Dimethylthiazole	
D166	Diphenyl ether	Phenyl ether; Diphenyl oxide
D167	1,3-Diphenyl-2-propanone	α,α -1-Diphenylacetone; Benzyl ketone; Dibenzyl ketone; α,α -Diphenylacetone
D168	Dipropyl disulfide	Propyldithiopropene; di- <i>n</i> -propyl disulfide; 1-Propyl disulfide; Propyl disulfide
D169	Dipropyl trisulfide	Propyl trisulfide; Propyl trithio propane; Propyl trisulphide

Order	General Name	Synonyms
D170	Disodium succinate	Succinic acid, disodium salt; Sodium succinate; Hept-2-enoic acid; Disodium butanedioic acid
D171	1,4-Dithiane	p-Dithiane; 1,4-Dithiacyclohexane; Tetrahydro-1,4-dithiin; Diethylene disulfide
D172	2,8-Dithianon-4-ene-4-carboxaldehyde	Methialdol; 5-(Methylthio)-2-(methyl-thio) methylpent-2-en-1-al; 2-Pentalen, 5-(methyl-thio-2-[(methylthio)methyl]-2-pentalen
D173	2,2'-(Dithiodimethylene)difuran	2-Furfuryl disulfide; Methyl 2-furylmethyl disulfide; Furfuryl methyl disulfide; Bis (2-furfuryl) disulfide; difurfuryl Disulfide; Furfuryl disulfide; Difurfuryl disulfide
D174	Divanillin	[1,1 -Biphenyl]-3,3 -dicarboxaldehyde, 6,6-dihydroxy-5,5 -dimethoxy-; 3,3 -Biphenyl-dicarboxaldehyde, 6,6 -dihydroxy-5,5 -dimethoxy-; 6,6 -Dihydroxy-5,5 -dimethoxybiphenyldicarboxaldehyde; 2,2 -Dihydroxy-3,3 -dimethoxy-5,5 -diformylbiphenyl; 5,5 -Bivanillin; Dehydrodivanillin
D175	2-trans-6-cis-Dodecadienal	2,6-Dodecadienal,(E,Z)-; Dodeca-2,6-dienal
D176	trans,trans-2,4-Dodecadienal	(E,E)-2,4-dodecadienal; Dodeca-2,4-dienal
D177	γ-Dodecalactone	4-Dodecanolide; 5-Octyldihydro-2(3H)-furanone; Dodeca-1,4-lactone; 4-n-Octyl-4-hydroxybutanoic acid lactone; Dodecano-1,4-lactone; Dodecanolide-1; 4-Hydroxydodecanoic acid, γ-lactone; γ-Octyl-γ-butyrolactone; γ-n-Octyl-γ-n-butyrolactone; Dodecanolide-1,4
D178	delta-Dodecalactone	5-Dodecanolide; 6-Heptyltetrahydro-2-pyrone; Dodeca-1,5-lactone; Dodecanolide-1,5; Dodecano-1,5-lactone; n-Heptyl-δ-valerolactone; 5-Hydroxydodecanoic acid, δ-lactone; delta-n-Heptyl-delta-valerolactone; delta-Heptyl-delta-valerolactone; Dodecanolide-1,5

Order	General Name	Synonyms
D179	trans-2-Dodecenal	2-Dodecenal; 3-Nonylacrolein; 2-Dodecenal; n-Dodecenal; Dodec-2-enal
D180	(Z)-4-Dodecenal	cis-4-Dodecenal; Tangerinal
D181	2-Dodecenoic acid	(E)-2-Decenoic acid, trans-2-Decenoic acid; 2-Decenoic acid
D182	Dodecyl isobutyrate	Dodecyl 2-methylpropanoate; Lauryl isobutyrate; Lauryl 2-methylpropanoate; Propanoic acid, 2-methyl-, dodecyl ester; Lauryl 2-methylpropionate
D183	Diethyl oxalate	Oxalic acid, diethyl ester; Diethyl ethanedioate; Ethyl oxalate; Diethyl ester kyseliny stavelove; Diethyl ester of oxalic acid; Diethyl ester, oxalic acid; Oxalic ether; Ethanedioic acid, diethyl ester
D184	Diphenylmethane	Benzene, 1,1'-methylenebis-; Methane, diphenyl-; Benzene, (phenylmethyl)-; Benzylbenzene; Ditan; Ditane; Benzene, benzyl-; Toluene, α -phenyl-; 1,1'-Dimethylenebis(benzene)
D185	Diethyl carbonate	Ethyl carbonate; Diatol; Ethoxyformic anhydride; Diaethylcarbonat; Diethyl ester of carbonic acid; Carbonic acid, diethyl ester
D186	2,4-Dimethylphenol	2,4-Xylenol; m-Xylenol; 1-Hydroxy-2,4-dimethylbenzene; 4-Hydroxy-1,3-dimethylbenzene; 4,6-Dimethylphenol; 1,3-Dimethyl-4-hydroxybenzene; 1,2,4-Xylenol; Phenol, 2,4-dimethyl-
D187	1,1-Dipropoxyethane	Acetaldehyde, dipropyl acetal; Acetaldehyde di-n-propyl acetal; Dipropyl acetal; n-Propyl acetal; 1-(1-Propoxyethoxy)propane; Ethane, 1,1-dipropoxy; Propane, 1,1'-[ethylidenebis(oxy)]bis-
D188	2,4-Dimethylpyridine	2,4-Lutidine; α,γ -Dimethylpyridine; 2,4-Lutidene; Pyridine, 2,4-dimethyl-
D189	Dimethyl malonate	Malonic acid, dimethyl ester; Dimethyl propanedioate; Methyl malonate; Dimethyl ester of malonic

Order	General Name	Synonyms
		acid;Propanedioic acid, dimethyl ester
D190	Dimethoxymethane	Dimethyl formal; Anesthenyl; Formal; Formaldehyde dimethyl acetal; Methoxymethyl methyl ether; Methylal; Methylene dimethyl ether; Methylene glycol dimethylether; Formaldehyde dimethyl; Methylenedioxydimethane; Formaldehyde methyl ketal; 2,4-Dioxapentane; Methyl formal; Dimethylacetal formaldehyde;Methane, dimethoxy-
D191	1,3-Diformylpropane	Glutaraldehyde; Pentanedial; Glutural; Glutardialdehyde; Glutaric acid dialdehyde; Glutaric aldehyde; Glutaric dialdehyde; 1,5-Pentanedione; Glutaraldehyd; Glutarol;Glutaclean; Sterihyde; Dioxopentane; Glutaralum; Gluter aldehyde; Pentane-1,5-dial; Potentiated acid glutaraldehyde;Glutaral;1,5-Pentanedial
D192	Dipropyl sulfide	Propyl sulfide; Dipropyl thioether; Propyl monosulfide; 4-Thiaheptane; 1,1'-Thiobispropane; n-Propyl sulfide; di-n-Propyl sulfide; Sulfide, n-propyl-; 1-(Propylsulfanyl)propane;Propane, 1,1'-thiobis-
D193	Dodecane	Adakane 12; Bihexyl; Dihexyl; n-Dodecane min; Duodecane;n-Dodecane
D194	Dodec-1-ene	α -Dodecene; n-Dodec-1-ene; Adacene 12; α -Dodecylene; Dodecylene α -; Dodecene-1;1-Dodecene;Tetrapropylene
D195	1,1-Diphenethoxyethane	Acetaldehyde diphenylethylacetal; (2-[1-(2-Phenylethoxy)ethoxy]ethyl)benzene;Benzene, 1,1'-[ethylidenebis(oxy-2,1-ethanediyl)]bis-;Phenylethylacetal
D196	Dimethylamine	N-Methylmethanamine; N,N-Dimethylamine;Methanamine, N-methyl-
D197	3,4-Dihydroxybenzaldehyde	Benzaldehyde, 3,4-dihydroxy-; 3,4-Dihydroxybenzenecarbonal; 1,2-Dihydroxy-4-formylbenzene; 4-Formyl-1,2-dihydroxybenzene; Protocatechualdehyde; Protocatechuic aldehyde;4-Formyl-1,2-benzenediol

Order	General Name	Synonyms
D198	Dibutyl succinate	Butanedioic acid, dibutyl ester; Succinic acid, dibutyl ester; Di-n-butyl succinate; Succinic acid di-n-butyl ester
D199	Diethyl maleate	Maleic acid, diethyl ester; Ethyl maleat; Diethyl (Z)-2-butenedioate; 2-Butenedioic acid (Z)-, diethyl ester
D200	Diethyl adipate	Adipic acid, diethyl ester; Diethyl hexanedioate; Ethyl δ -carboethoxyvalerate; Ethyl adipate; Diethyl adipate; 1,6-Diethyl hexanedioate; Diethylester kyseliny adipove; Hexanedioic acid, diethyl ester
D201	Diethoxymethane	Methane, diethoxy-; Ethane, 1,1'-[methylenebis(oxy)]bis-; Diethylformal; Ethoxymethyl ethyl ether; Ethylal; Formaldehyde diethyl acetal; 1-(Ethoxymethoxy)ethane; 1,1-Diethoxy methane
D202	3,3-Dimethylbutan-2-ol	Pinacolyl alcohol; tert-Butyl Methyl carbinol; 2,2-Dimethyl-3-butanol; 3,3-Dimethyl-2-butanol; Pinacolyl alcohol- tert-butyl methylcarbinol; 2-Butanol, 3,3-dimethyl-
D203	3,4-Dimethylpyridine	3,4-Lutidine; 3,4-Lutidene; Pyridine, 3,4-dimethyl-
D204	2,3-Dimethylpyridine	2,3-Lutidine; Pyridine, 2,3-dimethyl-
D205	2,4-Dimethylhexane	Hexane, 2,4-dimethyl-
D206	2,2-Dimethylhexane	Hexane, 2,2-dimethyl-
D207	3,5-Dimethylpyridine	3,5-Lutidine; Pyridine, 3,5-dimethyl-
D208	Diethyl Fumarate	Fumaric acid, diethyl ester; Ethyl fumarate; 2-Butenedioic acid, diethyl ester, (E)-; Diethylester kyseliny fumarove; Diethyl ester of (E)-2-Butenedioic acid; Diethyl (2E)-2-butenedioate; 2-Butenedioic acid (E)-, diethyl ester
D209	Diethyl nonanedioate	Nonanedioic acid, diethyl ester; Azelaic acid, diethyl ester; Diethyl azelaate; Diethyl azelate

Order	General Name	Synonyms
D210	2,5-Dimethylthiophene	Thiophene, 2,5-dimethyl-
D211	2,6-Dimethylocta-2,4,6-triene	cis-Allo-ocimene; Neo-allo-ocimene; allo-3,7-dimethyl-1,3,6-octatriene (allo-ocimene); neo-allo-3,7-dimethyl-1,3,6-octatriene (neo-allo-ocimene);2,4,6-Octatriene, 2,6-dimethyl-;Allo-Ocimene;(4E,6E)-2,6-Dimethyl-2,4,6-octatriene
D212	1,1-Diethoxyheptane	Heptanal, diethyl acetal; Heptaldehyde diethyl acetal; n-Heptanal diethyl acetal;Heptane, 1,1-diethoxy-
D213	2-Decanone	Decan-2-one; Methyl octyl ketone; Methyl n-octyl ketone; Octyl methyl ketone
D214	Di-isopentyl succinate	Succinic acid, diisopentyl ester
D215	Diethyl pentanedioate	Glutaric acid, diethyl ester; Diethyl glutarate; Ethyl glutarate; Propane-1,3-dicarboxylic acid diethyl ester;Pentanedioic acid, diethyl ester
D216	1,1-Dibutoxyethane	Butane, 1,1'-[ethylidenebis(oxy)]bis-; Acetaldehyde, dibutyl acetal; Di-n-butyl acetal; Ethane, 1,1-dibutoxy-; 1,1-Di-n-butoxyethane; Dibutyl acetal; 1-(1-Butoxyethoxy)butane;6-Methyl-5,7-dioxaundecane
D217	1,1-Dimethoxyhexane	Hexane, 1,1-dimethoxy-; hexanal dimethyl acetal
D218	6,10-Dimethylundecan-2-one	Hexahydropseudoionone; Pseudoionone, hexahydro-; Tetrahydrogeranylacetone; 6,10-Dimethyl-2-undecanone;2-Undecanone, 6,10-dimethyl-
D219	1,2-Dihydrolinalool	6-Octen-3-ol, 3,7-dimethyl-; 3,7-Dimethyl-6-octen-3-ol; Dihydrolinalol
D220	2,6-Dimethyloct-6-en-3-one	
D221	Dodecyl butyrate	1-Dodecanol, butanoate; Butanoic acid, dodecyl ester;Butyric acid, dodecyl ester

Order	General Name	Synonyms
D222	1,1-Diethoxypropane	Propionaldehyde, diethyl acetal; Propanaldiethylacetal;Propane, 1,1-diethoxy-
D223	1,1-Dihexyloxyethane	
D224	Decanal propyleneglycol acetal	
D225	1,1-Di-isobutoxyethane	Acetaldehyde, diisobutyl acetal; Propane, 1,1'-[ethylidenebis(oxy)]bis*2-methyl-; 1-(1-Isobutoxyethoxy)-2-methylpropane; Diisobutyl acetal; Ethane, 1,1-diisobutyloxy
D226	Dimethyl tetrasulfide	Dimethyl tetrasulphide; 1,4-Dimethyltetrasulfane;Tetrasulfide, dimethyl
D227	3,7-Dimethyloctanal	Tetrahydrocitra;Octanal, 3,7-dimethyl-
D228	Dodecan-2-one	Decyl methyl ketone; Methyl decyl ketone; Dodecanone-(2);2-Dodecanone
D229	Dodecyl propionate	Propanoic acid, dodecyl ester
D230	2,5-Dithiahexane	1,2-Bis(methylmercapto)ethane; 1,2-Bis(methylthio)ethane; 1,2-Bis(methylsulfanyl)ethane;Ethane, 1,2-bis(methylthio)-
D231	2,3-Dihydrofarnesene	
D232	Dodecan-2-ol	Dodecanol-2;2-Dodecanol
D233	1,1-Dipentyloxyethane	
D234	1,1-Di-isobutoxypropane	Propanal di-isobutyl acetal
D235	Dec-9-en-1-ol	ω -Decen-1-ol; Decylenic alcohol; 9-Decenol; ω -Decenol; 1-Decen-10-ol;9-Decen-1-ol
D236	1,1-Di-isobutoxy-2-methylpropane	
D237	1,1-Di-isobutoxypentane	Valeraldehyde di-isobutyl acetal; Pentanal diisobutyl acetal
D238	1,1-Di-isobutoxy-3-methylbutane	Butane, 1,1-diisobutoxy-3-methyl-

Order	General Name	Synonyms
D239	1,1-Di-(2-methylbutoxy)ethane	Acetaldehyde di(2-methylbutyl)acetal
D240	Dodecanal dimethyl acetal	1,1-Dimethoxydodecane; Dodecanal dimethyl acetal; Lauryl aldehyde dimethyl acetal;Dodecane, 1,1-dimethoxy-;Lauraldehyde, dimethyl acetal;n-Dodecanal dimethyl acetal
D241	2,6-Dimethyl-7-octen-2-ol	3,7-Dimethyl-1-octen-7-ol; Dihydromyrcenol; 2,6-Dimethyl-oct-7-en-2-ol; Mircenol, 6,10-dihydro;7-Octen-2-ol, 2,6-dimethyl-
D242	neo-Dihydrocarveol	5-Isopropenyl-2-methylcyclohexanol; neo iso dihydrocarveol
D243	1,1-Dimethylethyl propionate	Propionic acid, tert-butyl ester;t-Butyl propanoate; t-Butyl propionate; tert-butyl propanoate;Propanoic acid, 1,1-dimethylethyl ester
D244	3,7-Dimethyloctyl acetate	1-Octanol, 3,7-dimethyl-, acetate; 3,7-Dimethyl-1-octanol, acetate; Dihydrocitronellyl acetate; 3,7-Dimethyloctanyl acetate;Tetrahydrogeranyl acetate
D245	(E)-2-Decenol	trans-2-Decen-1-ol; (2E)-2-Decen-1-ol; Dec-2-enol;2-Decen-1-ol
D246	(+/-) cis- and trans-1,2-Dihydroperillaldehyde	(+/-)-Z- and E-1,2-Dihydroperillaldehyde;4-Isopropenylcyclohexane-carboxaldehyde
D247	2,6-Dimethoxy-4-vinylphenol	
D248	2,6-Dimethylocta-1,5,7-trien-3-ol	
D249	1,2-Dihydro-1,1,6-trimethylnaphthalene	Naphthalene, 1,2-dihydro-1,1,6-trimethyl-; 1,1,6-Trimethyl-1,2-dihydro-naphthalene (dehydro-ar-ionene); 1,1,6-trimethyl-1,2-dihydronaphthalene
D250	Dihydromyrcenol	
D251	2,5-Dimethyl-4-ethylloxazole	Oxazole, 4-ethyl-2,5-dimethyl-; 4-Ethyl-2,5-dimethyl-1,3-oxazole
D252	Decanal diethyl acetal	1,1-Diethoxydecane; 1,1-Bis(ethyloxy)decane; n-Decanal diethyl acetal;Decane, 1,1-diethoxy-

Order	General Name	Synonyms
D253	3,3-Diethoxybutan-2-one	
D254	1,1-Diethoxyundecane	
D255	1,1-Diethoxynonane	Nonanal diethyl acetal;n-Nonanal diethyl acetal;Nonane, 1,1-diethoxy-
D256	2,5-Dimethyl-2-vinylhex-4-enal	
D257	cis-4-Decenol	cis-4-Decen-1-ol; (4Z)-4-Decen-1-ol; 4Z-decen-1-ol; (Z)-4-decenol;(Z)-4-decen-1-ol;4-Decen-1-ol, (Z)-
D258	cis-Dec-7-eno-1,4-lactone	(Z)-5-(3-Hexenyl)dihydrofuranne-2(3H)-one
D259	11-Dodecenoic acid	dodecenoic acid
D260	Di-(1-propenyl)-sulfide (mixture of isomeres)	1Propene, 1-1'-thiobis-, (Z,Z)-;(E,Z) Bis(1-propenyl)sulfide;(E,E) Bis(1-propenyl)sulfide
D261	Dec-7-eno-1,4-lactone	
D262	2,3-Dihydro-5,7-dihydroxy-2-(3-hydroxy-4-methoxyphenyl)-4H-1-benzyopyran-4-one	Hesperetin; (±)-Hesperetin; (±)-5,7,3'-Trihydroxy-4'-methoxyflavanone; Eriodictyol 4'-monomethyl ether
D263	N-[2-(3,4-Dimethoxyphenyl)ethyl]-3,4-dimethoxycinnamic acid amide	Rubenamin;2-Propenamide, 3-(3,4-dimethoxyphenyl)-N-[2-(3,4-dimethoxyphenyl)ethyl]-;
D264	3,6-Dimethyl-2,3,3a,4,5,7a-hexahydrobenzofuran	3,6-Dimethyl-2,3,3a,4,5,7a-hexahydro-1-benzofuran; 3,9-Epoxy-p-Menth-1-ene
D265	1,1-Diethoxyhex-3-ene	cis-3-Hexenal diethyl acetal;3-Hexene, 1,1-diethoxy-, (Z)-;(3Z)-1,1-Diethoxy-3-hexene; (Z)-3-hexenal diethyl acetal
D266	2,6-Dimethyl-5-heptenal propyleneglycol acetal	
D267	2,7-Dimethylocta-5(trans),7-dieno-1,4-lactone	

Order	General Name	Synonyms
D268	2,4-Dimethyl-4-nonanol	dimethyl nonanol
D269	2,4-Dimethyl-3-oxazoline	dimethyl oxazoline
D270	Dimethyl benzyl carbonyl crotonate	2-methyl-1-phenyl-2-propyl crotonate
D271	N-3,7-Dimethyl-2,6-octadienylcyclopropylcarboxamide	Cyclopropanecarboxamide, N-[(2E)-3,7-dimethyl-2,6-octadienyl]-
D272	1,4-Dioxaspiro[4.5]decan-2-one, 3,9-dimethyl-6-(1-methylethyl)-	Freshone
D273	Dimethylbenzyl carbonyl hexanoate	
D274	9-Decen-2-one	Dec-9-en-2-one; Methyl oct-7-enyl ketone
D275	N1-(2,3-Dimethoxybenzyl)-N2-(2-(pyridin-2-yl)ethyl) oxalamide	Ethanediamide, N1-[(2,3-dimethoxyphenyl)methyl]- N2-[2-(2-pyridinyl)ethyl]-
D276	2,6-Dipropyl-5,6-dihydro-2H-thiopyran-3-carboxaldehyde	3,6-Dihydro-2,6-dipropyl-2H-thiopyran-5-carboxaldehyde
D277	N-(1,1-Dimethyl-2-hydroxyethyl)-2,2-diethylbutanamide	2,2-Diethyl-N-(2-hydroxy-1,1-dimethylethyl) butanamide; Butanamide, 2,2-diethyl-N-(2-hydroxy-1,1-dimethylethyl)-
D278	8-Decen-5-olide	2H-Pyran-2-one, tetrahydro-6-(3-pentenyl)-; 8-Decenoic acid, 5-hydroxy-, delta-lactone; 6-(pent-3-en-1-yl)tetrahydro-2H-pyran-2-one
D279	Dimethyl glutarate	Pentanedioic acid, bis[5-methyl-2-(1-methylethyl)cyclohexyl] ester; Glutaric acid, di-(p-menth-3-yl) ester
D280	Dimethyl adipate	Hexanedioic acid, dimethyl ester; Dimethyl hexanedioate; Adipic acid, dimethyl ester; Methyl adipate
D281	mixture of 2,4-, 3,5- and 3,6-Dimethyl-3-cyclohexenylcarbaldehyde	Trivertal; Ivy carbaldehyde; Mixture of 2,4-dimethylcyclohex-3-ene-1-carbaldehyde, 3,5-dimethylcyclohex-3-ene-1-carbaldehyde and 3,6-dimethylcyclohex-3-ene-1-carbaldehyde
D282	2,5-Dimethyl-6,7-dihydro-5H-cyclopentapyrazine	

Order	General Name	Synonyms
D283	mixture of 2,5 and 2,7-Dimethyl-6,7-dihydro-5H-cyclopentapyrazine	2,5-Dimethyl-6,7-dihydro-5H-cyclopenta[b]pyrazine and 2,7-Dimethyl-6,7-dihydro-5H-cyclopenta[b]pyrazine;
D284	4,5-Dimethyl-2-isobutylthiazole	2-Isobutyl-4,5-dimethyl thiazole; 4,5-Dimethyl-2-(2-methylpropyl)-1,3-thiazole; 4,5-Dimethyl-2-(2-methylpropyl)thiazole
D285	2,6-Dimethyl-5-heptenol	
D286	Diisopropyl adipate	Adipic acid, diisopropyl ester; Hexanedioic acid, bis(1-methylethyl) ester; Hexanedioic acid, 1,6-bis(1-methylethyl) ester; Isopropyl adipate
D287	3-(1-((3,5-Dimethylisoxazol-4-yl)methyl)-1H-pyrazol-4-yl)-1-(3-hydroxybenzyl)-imidazolidine-2,4-dione	3-[1-[(3,5-Dimethylisoxazol-4-yl)methyl]pyrazol-4-yl]-1-[(3-hydroxyphenyl)methyl]imidazolidine-2,4-dione
E001	(+/-)-2,8-Epithio-cis-p-menthane	6-Thiabicyclo[3.2.1]octane, 4,7,7-trimethyl-, (Z)-; Zestoril; 2,8-Epithio-p-menthane
E002	4,5-Epoxy-(E)-2-decenal	3-(3-Pentyloxiran-2-yl)prop-(E)-2-enal, 2-Propenal, 3-(3-pentyloxiranyl),(2E)-
E003	Epoxyoxophorone	7-Oxabicyclo[4.1.0]heptane-2,5-dione, 1,3,3-trimethyl-, 2,5,5-Trimethyl-2,2-epoxyoxolabovone-1,4-dione
E004	Epsilon-decalactone	6-Decanolide; 7-Butyl-2-oxooxacycloheptane; Deca-1,6-lactone; Decano-1,6-lactone; 6-Butylhexanolide; 7-butyl-2-oxepanone; 2-oxepanone, 7-butyl
E005	Epsilon-dodecalactone	6-Dodecanolid; 7-Hexyl-2-oxooxacycloheptane; Dodeca-1,6-lactone; Dodecano-1,6-lactone; 7-Hexyl-2-oxepanone; 2-oxepanone, 7-hexyl-
E006	Ethane-1,1-dithiol	1,1-Ethanedithiol
E007	1,2-Ethanedithiol	Dithioglycol; Ethylene mercaptan; 1,2-Dimercaptoethane; Ethylene dithioglycol; ethylenedimercaptan; Ethylene dimercaptan
E008	Ethanethioic acid,s-(2-methyl-3-furanyl) ester	3-(Acetylthio)-2-methylfuran; S-(2-methyl)-3-furyl thioacetate; 2-Methyl-3-thioacetatoxyfuran; 2-Methyl-3-furanthiol acetate

Order	General Name	Synonyms
E009	Ethanol	Ethyl alcohol; Methyl carbinol; Dehydrated alc.; Ethyl hydrate; Ethyl hydroxide
E010	1-Ethoxy-3-methyl-2-butene	Prenyl ethyl ether; Ethoxy-3-methyl-2-butene; Ethyl 3-methylbut-2-enyl ether
E011	2-Ethoxy-3-methylpyrazine	
E012	p-Ethoxybenzaldehyde	Homoanisaldehyde; 4-Ethoxybenzaldehyde
E013	o-(Ethoxymethyl)phenol	Phenol, 2-(ethoxymethyl)-; o-(ethoxymethyl)hydroxybenzene; o-hydroxybenzyl ethyl ether; α -Ethoxy-o-cresol; 2-(Ethoxymethyl)phenol
E014	2-Ethoxythiazole	2-Thiazolyl ethyl ether; Ethyl-2-thiazosyl ether
E015	Ethyl (p-tolyloxy)acetate	Vinegar naphtha; Ethyl p-cresoxy acetate; Ethyl (4-methylphenoxy)acetate; Ethyl cresoxyacetate
E016	Ethyl 10-undecenoate	Ethyl undec-10-enoate; Ethyl 10-hendecenoate; Ethyl undecylenoate
E017	Ethyl 2-(methyldithio)propionate	Ethyl α -(methyldithio)propionate
E018	Ethyl 2-(methylthio)acetate	Ethyl(methylthio)acetate, Ethyl β -(methylthio)acetate; Ethyl 2-methylthioacetate
E019	Ethyl 2,4,7-decatrienoate	Ethyl deca-2,4,7-trienoate; 2,4,7-Decatrienoic acid, ethyl ester
E020	Ethyl 2,4-dioxohexanoate	Ethyl-2,4-diketocaproate; Ethyl propionyl pyruvate; Ethyl propionylpyruvate
E021	Ethyl 2-acetyl-3-phenylpropionate	Ethyl 2-acetyldihydrocinnamate; Ethyl 2-benzylacetoacetate; Ethyl α -acetylhydroxycinnamate; Ethyl benzyl acetoacetate; Ethyl-3-oxo-2-benzylbutanoate
E022	S-Ethyl 2-acetylaminoethanethioate	(Acetylamino)ethanethioic acid, S-ethyl ester; S-ethyl 2-acetamidoethanethiolate; N-Acetylthioglycine, S-ethyl ester; N-Acetylglycinethiol ethyl ester

Order	General Name	Synonyms
E023	Ethyl 2-ethyl-3-phenylpropionate	Ethyl 2-benzylbutyrate; Ethyl 2-ethyl dihydrocinnamate; Ethyl 2-ethyl-3-phenylpropanoate; Ethyl α -ethyl dihydrocinnamate; Ethyl benzylbutyrate
E024	Ethyl 2-mercaptopropionate	ethyl thioacetate; 2-Mercapto propionic acid, ethyl ester
E025	Ethyl 2-methyl-3,4-pentadienoate	ethyl 2-methylpenta-3,4-dienoate; 2,4-Pentadienoic acid, 2-methyl-ethyl ester
E026	Ethyl 2-methyl-3-pentenoate	ethyl 2-methylpent-3-enoate; 3-Pentenoic acid, 2-methyl-, ethyl ester
E027	Ethyl 2-methyl-4-pentenoate	ethyl 2-methylpent-4-enoate; 4-Pentenoic acid, 2-methyl-, ethyl ester
E028	Ethyl 2-methylbutyrate	Ethyl 2-methylbutanoate
E029	Ethyl 2-methylpentanoate	Ethyl 2-methylvalerate; Pentanoic acid, 2-methyl, ethyl ester
E030	Ethyl 2-nonynoate	Ethyl octyne carbonate; Ethyl octyne carboxylate; Ethyl non-2-yanoate; Ethyl hexyl propiolate
E031	Ethyl 3-(2-furyl)propionate	Ethyl 2-furanpropionate; Ethyl furfurylacetate; Ethyl furylpropionate;
E032	Ethyl 3-(furfurylthio)propionate	Ethyl 3-(2-furfurylthio)propionate; Ethyl β -furfuryl- α -thiopropionate; propanoic acid, 3-[(2-furanylmethyl)thio]-, ethyl ester; Ethyl β -furfuryl- α -thiopropionate
E033	Ethyl 3-(methylthio)butyrate	
E034	(+/-)Ethyl 3-acetoxy-2-methylbutyrate	Butanoic acid, 3-(acetyloxy)-2-methyl, ethyl ester; 3-Acetoxy-2-methylbutyric acid, ethyl ester
E035	Ethyl 3-hexenoate	Hydrosorbic acid, ethyl ester
E036	Ethyl 3-hydroxybutyrate	Ethyl β -hydroxybutyrate; Ethyl-3-hydroxybutanoate

Order	General Name	Synonyms
E037	Ethyl 3-hydroxyhexanoate	Hexanoic acid, 3-Hydroxy-, ethyl ester, ethyl 3-hydroxycaproate
E038	(+/-)-Ethyl 3-mercaptobutyrate	3-Mercaptobutyric acid, ethyl ester
E039	Ethyl 3-mercaptopropionate	Ethyl 3-thiopropionate; Propanoic acid, 3-mercapto-, ethyl ester
E040	Ethyl 3-methylpentanoate	Ethyl 3-methylvalerate; Pentanoic acid, 3-methyl-, ethyl ester
E041	Ethyl 3-methylthiopropionate	Ethyl- β -methylthiopropionate; ethyl methylmercaptopropionate
E042	Ethyl 3-oxohexanoate	Ethyl- β -ketohehexanoate; Ethyl α -ketohehexanoate; Ethyl 3-ketohehexanoate; hexanoic acid, 3-oxo-, ethyl ester
E043	Ethyl 3-phenylpropionate	Ethyl dihydrocinnamate; Ethyl hydrocinnamate
E044	Ethyl 4-(acetylthio)butyrate	Butanoic acid, 4-(acetylthio)-, ethyl ester
E045	Ethyl 4-(methylthio)butyrate	Butanoic acid, 4-methylthio-, ethyl ester
E046	2-Ethyl 4-methylthiazole	Thiazole, 2-ethyl-4-methyl-
E047	Ethyl 4-phenylbutyrate	Butanoic acid, 4-phenyl, ethyl ester; Ethyl 4-phenylbutanoate; Ethyl phenylbutyrate; Ethyl- γ -phenylbutyrate
E048	Ethyl 5-(methylthio)valerate	Pentanoic acid, 5-(methylthio)-, ethyl ester
E049	Ethyl 5-hexenoate	5-Hexenoic acid, ethyl ester
E050	Ethyl acetate*	Ethyl ethanoate; Acetic ether; Vinegar naphtha
E051	Ethyl acetoacetate*	Ethyl acety acetate; Ethyl 3-oxobutyrate; Ethyl acetylacetate; Ethyl 3-ketobutyrate; Ethyl 3-oxobutanoate; Acetoacetic ester; Ethyl β -ketobutyrate; ethyl-3-oxobutanoate
E052	Ethyl aconitate(mixed esters)	Ethyl-2-carboxyglutaconate; Ethyl 1-propene-1,2,3-tricarboxylate; Mixture of mono-di-and tri-ethyl propene-1,2,3-tricarboxylate; Triethyl aconitate

Order	General Name	Synonyms
E053	Ethyl acrylate	Ethyl propeonate
E054	Ethyl anthranilate	Ethyl-2-aminobenzoate; Ethyl <i>o</i> -aminobenzoate
E055	Ethyl benzoate	Benzenecarboxylate; Ethyl benzenecarboxylate
E056	Ethyl benzoylacetate	Ethyl 3-phenyl-3-oxopropionate; Benzoyl acetic ester; ethyl β -keto- β -phenyl propionate; ethyl 3-phenyl-3-oxopropanoate
E057	Ethyl β -phenylpropionate	Ethyl 3-phenyl-2,3-epoxypropionate; ethyl α,β -epoxy- β -phenylpropionate; ethyl phenylglycidate; Ethyl α,β -epoxy- α -phenylpropionate; Ethyl 3-phenylglycidate
E058	Ethyl brassylate	Ethylene undecane dicarboxylate; Tridecanedioic acid cyclic ethylene glycol diester; Ethylene glycol brassylate, cyclic diester; Cyclo-1,13-ethylenedioxytridecan-1,13-dione; Emeressence 1150 (EMEQ); musk T (TAKA); 1,4-Dioxacycloheptadecan-5,17-dion; ethyleneglycol tridecadioic acid cyclic diester; MC-5(Soda); Ethylene brassylate
E059	Ethyl butyrate *	Ethyl butanoate; Ethyl n-butanoate; Butyric ether; Ethyl butanoate
E060	Ethyl cinnamate *	Ethyl phenylacrylate; cinnamic acid, ethyl ester; Ethyl β -phenylacrylate; ethyl-3-phenylpropenoate; Ethyl trans-cinnamate
E061	Ethyl cis-3-hexenoate	Ethyl Z-3-hexenoate; Ethyl (3Z)-hexenoate
E062	Ethyl cis-4,7-octadienoate	Ethyl octa-4,7-dienoate; Ethyl (Z)-4,7-octadienoate; 4,7-octadienoic acid, ethyl ester, (Z)-
E063	Ethyl cis-4-heptenoate	4-Heptenoic acid, ethyl ester; (Z)-Ethyl cis-hept-4-enoate; cis-4-Heptenoic acid ethyl ester

Order	General Name	Synonyms
E064	Ethyl cis-4-octenoate	(Z)-ethyl oct-4-enoate; Ethyl oct-4-enoate
E065	Ethyl cyclohexanecarboxylate	Cyclohexanecarboxylic acid, ethyl ester
E066	Ethyl cyclohexanepropionate	Ethyl hexahydrophenylpropionate; Cyclohexane ethyl propionate; Ethyl-3-cyclohexyl- propanoate; Ethyl cyclohexylpropionate; Hexahydro phenylethyl propionate; Ethyl 3-cyclohexylpropionate
E067	Ethyl decanoate*	Ethyl caprinate; Ethyl caprate; Ethyl decylate
E068	Ethyl dodecanoate	Ethyl laurate; Ethyl dodecylate
E069	Ethyl formate	Ethyl methanoate; Formic ether
E070	Ethyl furfuryl ether	Furfuryl ethyl ether; 2-(Ethoxymethyl)furan
E071	Ethyl heptanoate*	Ethyl caproate; Ethyl heptoate; ethyl heptylate, Ethyl oenanthatate; Oenanthic ester
E072	Ethyl hex-2-enoate	Ethyl hex-2-enoate; Ethyl (E)-2-hexenoate; 2-hexenoic acid, ethyl ester, (E)-
E073	Ethyl hexadecanoate	Ethyl cetylalate; ethyl palmitate; Hexadecanoic acid, ethyl ester
E074	Ethyl hexanoate*	Capronic ether absolute; Ethyl caproate; Ethyl capronate; ethyl hexylate
E075	Ethyl isobutyrate	Ethyl 2-methylpropanoate; Propanoic acid, 2-methyl-ethyl ester; Ethyl isobutanoate
E076	Ethyl isovalerate*	Ethyl isovalerianate; Ethyl 3-methylbutanoate; Ethyl isopentanoate; Ethyl β -methylbutyrate
E077	Ethyl lactate	Ethyl 2-hydroxypropanoate; Ethyl α -hydroxy propionate
E078	Ethyl levulinate	Ethyl 4-ketovalerate; Ethyl acetylpropanoate; Ethyl γ -ketovalerate; Ethyl-4-oxopentanoate; Ethyl 4-oxovalerate; Ethyl laevulinate; Ethyl 4-oxopentanoate; Ethyl laevulinate

Order	General Name	Synonyms
E079	Ethyl maltol	2-Ethyl-3-hydroxy-4h-pyran-4-one; Veltol-plus; 3-Hydroxy-2-ethyl-4-pyrone; 2-Ethyl pyromeconic acid; 3-Ethyl-2-hydroxy-4H-pyran-4-one; 2-ethyl-3-ol-4H-pyran-5-one; 2-Ethyl-3-ol-4H-pyran-4-one
E080	Ethyl methyl disulfide	Methyldisulfanylethane; 2,3-Dithiapentane
E081	Ethyl methyl-p-tolylglycidate	Ethyl 2,3-epoxy-3-methyl-3-p-tolylpropionate; Ethyl methyl-p-methylphenylglycidate; Oxiranecarboxylic acid, 3-methyl-3(4-methylphenyl)-ethyl ester; Ethyl 3-methyl-3-(4-methylphenyl)oxiranecarboxylate; Ethyl 2,3-epoxy-3-methyl-3-ptolylpropionate
E082	Ethyl N-ethylantranilate	Benzoic acid, 2-(ethylamino)-, ethyl ester; Ethyl o-(ethylamino)benzoate
E083	Ethyl nitrite	Nitrous ether; spirit of nitrous ether
E084	Ethyl N-methylantranilate	Benzoic acid, 2-(methylamino)-, ethyl ester; Anthranilic acid, N-methyl-, ethyl ester; Ethyl 2-(methylamino)benzoate
E085	Ethyl nonanoate	Ethyl nonylate; Ethyl pelargonate
E086	Ethyl octadecanoate	Ethyl stearate; Octadecanoic acid, ethyl ester
E087	Ethyl octanoate*	Ethyl caprylate; Ethyl octylate
E088	Ethyl oleate	Ethyl cis-9-octadecenoate; Ethyl 9-octadecenoate
E089	Ethyl p-anisate	Ethyl p-methoxybenzoate; Ethyl 4-methoxybenzoate; Ethyl anisate
E090	Ethyl pentanoate	Ethyl valerate; Ethyl valerianate

Order	General Name	Synonyms
E091	Ethyl phenylacetate*	α -Toluic acid, ethyl ester; Ethyl α -toluate; Ethyl benzeneacetate
E092	Ethyl propionate*	Ethyl propanoate; Propionic ether
E093	Ethyl propyl disulfide	1-Ethyldisulfanylpropane, 3,4-Dithiaheptane
E094	Ethyl propyl trisulfide	3,4,5-Trithiaoctane
E095	Ethyl pyruvate	Ethyl acetylformate; ethyl pyroracemate; Ethyl α -ketopropionate; Ethyl-2-oxopropanoate
E096	Ethyl r-anisate	
E097	o-Ethyl s-(2-furylmethyl) thiocarbonate	O-Ethyl s-(2-furylmethyl thiocarbonate; O-Ethyl s-(furan-2-yl methyl)thiocarbonate; O-Ethyl S-(2-furanylmethyl)thiocarbonate; O-Ethyl S-(2-furanylmethyl)carbonothioate; Ethoxy carbonyl furfurylthiol
E098	Ethyl salicylate	Salicylic ether; Sal ethyl; salicylic acid, ethyl ester; Ethyl 2-hydroxybenzoate; Ethyl o-hydroxy benzoate
E099	Ethyl sorbate	Ethyl-2,4-hexadienoate; Ethyl hexa-2,4-dienoate; Ethyl sorbate
E100	Ethyl tetradecanoate	Ethyl myristate
E101	Ethyl thioacetate	Acetic acid, thioethyl ester; Thioacetic acid, ethyl ester, S-ethyl acetothioate; Acetic acid thio ethyl; Ethanethioic acid, S-ethyl ester
E102	Ethyl tiglate	Ethyl trans-2-methylcrotonate; Ethyl 2-methylcrotonate; Ethyl trans-2,3-dimethyl acrylate; Ethyl trans-2-methyl-2-butenolate; Tiglic acid ethyl ester
E103	Ethyl trans-2, cis-4-decadienoate	Ethyldeca-2(cis),4(trans)-dienoate; Ethyl (2E,4Z)-decadienoate
E104	N-Ethyl trans-2-cis-6-nonadienamide	2,6-Nonadienamide, N-ethyl-, (2E,6Z)-

Order	General Name	Synonyms
E105	Ethyl trans-2-decenoate	Ethyl dec-2-enoate; 2-Decenoic acid, ethylester, (E)-
E106	Ethyl trans-2-hexenoate	
E107	Ethyl trans-2-octenoate	Ethyl 2-octenoate; 2-Octenoic acid, ethyl ester, (E)-; Ethyl oct-2(trans)-enoate
E108	Ethyl trans-4-decenoate	Ethyl dec-4-enoate; 4-Decenoic acid, ethyl ester, (E)-
E109	Ethyl trans-butenoate	Ethyl crotonate; ethyl α -crotonate; Ethyl trans-2-butenoate; trans-2-butenoic acid ethylester
E110	Ethyl undecanoate	Ethyl hendecanoate; ethyl undecylate; Ethyl undecanoate
E111	Ethyl vanillin*	Bourbonal; ethyl protal; 3-Ethoxyprotocatechualdehyde; Ethylprotocatechualdehyde-3-ethyl ether; 3-Ethoxy-4-hydroxybenzaldehyde
E112	Ethyl vanillin β -D-glucopyranoside	Glucoethylvanillin; 3-ethoxy-4-(β -glucopyranosyloxy)benzaldehyde
E113	Ethyl vanillin isobutyrate	2-Ethoxy-4-formylphenyl isobutyrate; 2-Ethoxy-4-formylphenyl 2-methylpropanoate
E114	Ethyl vanillin propylene glycol acetal	2-(3-Ethoxy-4-hydroxyphenyl)-4-methyl-1,3-dioxolane; 2-ethoxy-4-(4-methyl-1,3-dioxolan-2yl)phenol
E115	2-Ethyl(or methyl)-(3-, 5- or 6-)methoxypyrazine	2-Methyl(or ethyl)-(3,5 and 6)-methoxypyrazine; 2,5, or 6-Methoxy-3-ethylpyrazine; Mixture of 2-ethyl-3-methoxypyrazine and 2-ethyl-5-methoxypyrazine and 2-ethyl-6-methoxypyrazine and 2-methyl-3-methoxypyrazine and 2-methyl-5-methoxypyrazine and 2-methyl-6-methoxypyrazine; 3-Ethyl-(5 or 6)-methoxypyrazine, 5 or 6-Methoxy-3-ethyl-pyrazine
E116	2-Ethyl-1,3,3-trimethyl-2-norbornanol	Ethyl fenchol; 2-Ethylfenchol; 2-norbornanol, 2-ethyl-1,3,3-trimethylbicyclo[2.2.1]- heptan-2-ol
E117	2-Ethyl-1-hexanol	2-Ethylhexan-1-ol; 2-Ethyl hexyl alcohol

Order	General Name	Synonyms
E118	4-Ethyl-2,6-dimethoxyphenol	4-Ethylsyringol; phenol, 4-ethyl-2,6-dimethoxy-; 2,6-Dimethoxy-4-ethylphenol
E119	3-Ethyl-2,6-dimethylpyrazine	2,6-Dimethyl-3-ethylpyrazine; 2-Ethyl-3,5-dimethylpyrazine; 3,5-Dimethyl-2-ethylpyrazine
E120	1-Ethyl-2-acetyl pyrrole	1-(n-ethylpyrrol-2-yl) ethanone; 1-Ethyl-2-acetylazole; 2-Acetyl-1-ethylpyrrole
E121	2-Ethyl-2-heptenal	2-ethyl-3-butylacrolein; 2- Ethylhept-2-enal
E122	5-Ethyl-2-hydroxy-3-methylcyclopent-2-en-1-one	1,2-cyclohexanedione; 2-Cyclopenten-1-one, 5-ethyl-2-hydroxy-3-methyl-; 5-ethyl-3-methylcyclopent-2-en-1-one
E123	3-Ethyl-2-hydroxy-4-methylcyclopent-2-en-1-one	2-Cyclopenten-1-one, 3-ethyl-2-hydroxy-4-methyl-; 3-Ethyl-2-cyclopenten-2-ol-1-one; ethylcyclopentenolone; 3-ethyl-4-methylcyclopent-2-en-1-one
E124	N-Ethyl-2-isopropyl-5-methylcyclohexane carboxamide	n-Ethyl-p-menthane-3-carboxamide; Cyclohexanecarboxamine, N-ethyl-5-methyl-2-(1-methylethyl)-; N-ethyl-p-menthane-3-
E125	5-Ethyl-2-methylpyridine	2-Methyl-5-ethylpyridine; pyridine, 5-ethyl-2-methyl-; 5-Ethyl-2-picoline
E126	2-Ethyl-3,(5 or 6)-dimethylpyrazine	3,5-Dimethyl-2-ethylpyrazine; 2,5-Dimethyl-3-ethylpyrazine; Mixture of 2-ethyl-3,5-dimethylpyrazine and 3-ethyl-2,5-dimethylpyrazine; 2,6- Dimethyl-3-ethylpyrazine; 2-Ethyl-3,6-dimethyl pyrazine; 3-Ethyl-2,5(6)-dimethyl pyrazine; 3,6-Dimethyl-2-ethylpyrazine
E127	5-Ethyl-3-hydroxy-4-methyl-2(5H)-furanone	2-Hydroxy-3-methyl-2-hexenoic acid, γ -lactone; 2-Ethyl-3-methyl-4-hydroxydihydro-2,5-furan-5-one; 2-hydroxy-3-methyl- γ -2-hexene-lactone; Ethyl Fenugreek lactone; Emoxyfurone
E128	2-Ethyl-3-methylpyrazine	2-ethyl-3-methyl-1,4-diazine; 2-Methyl-3-ethylpyrazine

Order	General Name	Synonyms
E129	2-Ethyl-4,5-dimethyloxazole	4,5-Dimethyl-2-ethyloxazole; Oxazole, 2-ethyl-4,5-dimethyl-
E130	2-Ethyl-4-hydroxy-5-methyl-3(2H)-furanone	Homofuronol (GIV); 5-Ethyl-4-hydroxy-2-methyl-3(2H)-furanone; 3(2H)-furanone, 5-ethyl-4-hydroxy-2-methyl-
E131	2-Ethyl-5-methylpyrazine	2-Methyl-5-ethylpyrazine; 2-Ethyl-5-methyl-1,4-diazine
E132	2-Ethyl-6-methylpyrazine	Pyrazine, 2-ethyl-6-methyl; 2-Methyl-6-ethylpyrazine; 6-Methyl-2-ethylpyrazine; 2-Ethyl-6-methyl-1,4-diazine
E133	Ethylamine	1-Aminoethane; Aminoethane; Monoethylamine; n-Ethylamine
E134	4-Ethylbenzaldehyde	Benzaldehyde, 4-ethyl; <i>p</i> -ethylbenzaldehyde
E135	α -Ethylbenzyl butyrate	1-Phenyl-1-propyl butyrate; Ethyl phenyl carbonyl butyrate; α -phenylpropyl butyrate; 1-Phenylpropyl butyrate; α -Ethylbenzyl butyrate
E136	2-Ethylbutyl acetate	β -Ethylbutyl acetate
E137	2-Ethylbutyraldehyde	2-Ethylbutanal; diethylacetaldehyde
E138	2-Ethylbutyric acid	2-Ethylbutyric acid; Diethylacetic acid; α -Ethylbutyric acid
E139	Ethylcyclopentenolone	3-Ethyl-2-hydroxy-2-cyclopenten-1-one; 3-Ethylcyclopentane-1,2-dione; 3-Ethyl-2-cyclopenten-2-ol-1-one; 2-Hydroxy-3-ethyl-2-cyclopenten-1-one; Ethyl cyclopentenolone; Ethyl cyclopentalone
E140	2-Ethylfuran	2-Ethyloxole
E141	4-Ethylguaiacol	2-Methoxy-4-ethylphenol; 1-hydroxy-2-methoxy-4-ethylbenzene; Ethyl 3(2-furyl)propionate; 4-Ethyl-2-

Order	General Name	Synonyms
		methoxyphenol; Homocresol; 2-Methoxy-2-ethylphenol
E142	2-Ethylhexanethiol	2-Ethylhexane-1-thiol; 2-Ethylhexyl mercaptan
E143	1-Ethylhexyl tiglate	1-Ethylhexyl 2-methylcrotonate; Octen-3-yl 2-methyl-2-butenate; 2-Butenoic acid, 2-methyl-, 1-ethylhexyl ester, (E)-; 1-Ethylhexyl 2-methyl-2-butenate; 1-Ethylhexyl α -methylcrotonate; 3-octyl 2-methylcrotonate; 3-Octyl 2-methyl-2-butenate; 3-Octyl tiglate; Oct-3-yl 2-methylcrotonate; Oct-3-yl tiglate
E144	(+/-)-4-Ethyloctanal	Octanal, 4-ethyl; Excital
E145	4-Ethyloctanoic acid	4-ethylcaprylic acid
E146	p-Ethylphenol	4-Hydroxyethylbenzene; 1-Ethyl-4-hydroxybenzene; 4-Ethylphenol
E147	2-Ethylpyrazine	2-Ethyl-1,4-diazine; Ethylpyrazine; 2-Ethyl pyrazine
E148	3-Ethylpyridine	β -Ethylpyridine; β -lutidine
E149	2-(Ethylthio)phenol	2-Ethylphenyl mercaptan; 2-Ethylbenzenethiol
E150	Eucalyptol*	Cajeputol; cineole; 1,8-epoxy- <i>p</i> -methane; 1,8- Cineole; 1,8-Oxido- <i>p</i> -menthane; 1,3,3-Trimethyl-2-oxabicyclo[2.2.2]octane
E151	Eugenol*	4-Hydroxy-3-methoxy-1-allylbenzene; eugenic acid; 2-Methoxy-4-(2-propen-1-yl) phenol; 1-Hydroxy-2-methoxy-4-propenylbenzene; 4-Allylcetachol-2-methyl ether; 2-methoxy-4-allylphenol; 4-Allylguaiacol; 4-Allyl-2-methoxyphenol; 1-Hydroxy-2-methoxy-4-allyl benzene; 2-Methoxy-4-prop-2-enylphenol; 1-Hydroxy-2-methoxy-4-(2-propenyl)benzene

Order	General Name	Synonyms
E152	Eugenyl acetate	2-Methoxy-4-(2-propen-1-yl)phenyl acetate; 4-allyl-2-methoxyphenyl acetate; Acetyl eugenol; eugenol acetate; 2-methoxy-4-(3-propenyl)phenyl acetate; Aceteugenol; 2-Methoxy-4-phenyl acetate
E153	Eugenyl benzoate	4-Allyl-2-methoxyphenyl benzoate; benzoyl eugenol; eugenol benzoate
E154	Eugenyl formate	4-(2-propen-1-yl)-2-methoxyphenyl formate; 4-Eugenyl formate; 4-Allyl-2-methoxyphenyl formate; 4-(2-propenyl)-2-methoxyphenyl formate; Eugenol formate
E155	Eugenyl isovalerate	4-Allyl-2-methoxyphenyl isovalerate; Butanoic acid, 3-methyl-, 2-methoxy-4-(2-propenyl)phenyl ester
E156	Ethanethiol	Ethyl hydrosulfide; Ethyl mercaptan; Ethyl sulfhydrate; Ethyl thioalcohol; Mercaptoethane; Thioethanol; Thioethyl alcohol; 1-Mercaptoethane
E157	(+/-) Ethyl 2-hydroxy-2-methylbutyrate	Ethyl 2-methylacrylate; Butyric acid, 2-hydroxy-2-methyl-, ethyl ester; Butanoic acid, 2-hydroxy-2-methyl-, ethyl ester, (±); 2-Hydroxy-2-methylbutyric acid ethyl ester; ethyl 2-hydroxy-2-methylbutyrate ; Butyric acid, 2-hydroxy-2-methyl-
E158	2-Ethylphenol	Phenol, o-ethyl-; o-Ethylphenol; Phlorol; 1-Ethyl-2-hydroxybenzene; 1-Hydroxy-2-ethylbenzene; Florol; Ethylphenol; Phenol, 2-ethyl-
E159	Ethyl methacrylate	Methacrylic acid, ethyl ester; Ethyl 2-methyl-2-propenoate; Ethyl 2-methylacrylate; Ethyl methyl acrylate; Ethyl- α -methyl acrylate; 2-Methylacrylic acid, ethyl ester; 2-Methyl-2-propenoic acid ethyl ester; Ethyl 2-methacrylate; 2-Propenoic acid, 2-methyl-, ethyl ester

Order	General Name	Synonyms
E160	2-Ethylbutan-1-ol	1-Butanol, 2-ethyl-; Pseudohexyl alcohol; 2-Ethylbutyl alcohol; 3-Methylolpentane; 2-Ethylbutanol; 2-Ethylbutanol-1; sec-Hexyl alcohol; sec-Pentyl carbinol; 3-Pentyl carbinol; Ethylbutanol; sec-Hexanol; 2-Ethyl-1-butanol
E161	2-Ethylpyridine	α -Ethylpyridine; Pyridine, 2-ethyl-
E162	2-Ethylhexyl acetate	2-Ethyl-1-hexanol acetate; 2-Ethyl-1-hexyl acetate; β -ethylhexyl acetate; 2-Ethylhexyl ethanoate; Acetic acid α -ethylhexyl ester; 2-Ethylhexanyl acetate; 2-Ethylhexylester kyseliny octove; Ethyl hexyl acetate; Ethyl(2)-hexyl acetate; Octyl acetate; Acetic acid, 2-ethylhexyl ester
E163	2-Ethyl hexanal	α -Ethylcaproaldehyde; Butylethylacetaldehyde; Ethylbutylacetaldehyde; 2-Ethylhexaldehyde; 2-Ethylhexylaldehyde; 3-Formylheptane; 2-Ethylcaproaldehyde; Ethylhexaldehyde; 2-Ethylcapronaldehyde α -Ethylhexanal; 2-Ethylhexan-1-al; Hexanal, 2-ethyl-
E164	2-Ethyl hexanoic acid	α -Ethylcaproic acid; α -Ethylhexanoic acid; Butylethylacetic acid; Ethylhexanoic acid; Ethylhexoic acid; 2-Butylbutanoic acid; 2-Ethylcaproic acid; 3-Heptanecarboxylic acid; Kyselina heptan-3-karboxylova; 2-Ethyl-1-hexanoic acid; 2-Ethylcapronic acid; Hexonic acid, 2-ethyl-; 2-Ethylhexoic acid; Hexanoic acid, 2-ethyl-
E165	4-Ethylpyridine	Pyridine, 4-ethyl-; γ -Ethylpyridine
E166	Ethyl isothiocyanate	Isothiocyanic acid, ethyl ester; Ethyl mustard oil; Isothiocyanatoethane; Mustard oil; 1-Isothiocyanatoethane; Ethane, isothiocyanato-
E167	Ethyl linolate(Ethyl (Z,Z)-9,12-octadecadienoate)	Linoleic acid ethyl ester; 9,12-Octadecadienoic acid (Z,Z)-, ethyl ester; Ethyl cis,cis-9,12-octadecadienoate; Mandenol; Ethyl (9Z,12Z)-9,12-octadecadienoate; ethyl (Z,Z)-9,12-octadecadienoate; Ethyl linoleate

Order	General Name	Synonyms
E168	Ethyl nicotinate	Nicotinic acid, ethyl ester; β -Pyridinecarboxylic acid ethyl ester; Ethyl 3-pyridinecarboxylate; Ignicut; 3-Ethoxycarbonyl)pyridine; 3-Carboethoxypyridine; Picolinic acid ethyl ester; 3-Pyridinecarboxylic acid, ethyl ester
E169	Ethyl 2-furoate	2-Furoic acid, ethyl ester; Ethyl furan-2-carboxylate; Ethyl pyromucate; Ethyl 2-furancarboxylate; Furan-2-carboxylic acid ethyl ester; 2-Carboethoxyfuran; Ethyl furoate; 2-Furancarboxylic acid, ethyl ester
E170	Ethyl vanillate	Vanillic acid, ethyl ester; 4-Hydroxy-3-methoxybenzoic acid ethyl ester; Ethyl 4-hydroxy-3-methoxybenzoate; m-Anisic acid, 4-hydroxy-, ethyl ester; 3-Methoxy-4-hydroxybenzoic acid, ethyl ester; Benzoic acid, 4-hydroxy-3-methoxy-, ethyl ester
E171	3-Ethylphenol	Phenol, 3-ethyl-; Phenol, m-ethyl-; m-Ethylphenol; 1-Ethyl-3-hydroxybenzene; 1-Hydroxy-3-ethylbenzene
E172	Ethyl furfuracrylate	
E173	Ethyl 3-methylcrotonate	Crotonic acid, 3-methyl-, ethyl ester; Ethyl β,β -dimethylacrylate; Ethyl dimethylacrylate; Ethyl isopropylideneacetate; Ethyl senecioate; Ethyl 3-methyl-2-butenate; Ethyl 3,3-dimethylacrylate; Ethyl β -methylcrotonate; Ethyl 3-methylbut-2-enoate; -Methyl-2-butenic acid, ethyl ester; 2-Butenoic acid, 3-methyl-, ethyl ester
E174	Elemol	o-Menth-8-ene-4-methanol, α,α -dimethyl-1-vinyl-, (1S,2S,4R)-(-)-; 2-(3-Isopropenyl-4-methyl-4-vinylcyclohexyl)-2-propanol; Cyclohexanemethanol, 4-ethenyl- $\alpha,\alpha,4$ -trimethyl-3-(1-methylethenyl)-, [1r-(1 α ,3 α ,4 β)]-
E175	2-Ethylthiophene	Thiophene, 2-ethyl-
E176	Ethyl 3-octenoate	3-Octenoic acid, ethyl ester; Ethyl (3E)-3-octenoate; Ethyl oct-3-enoate

Order	General Name	Synonyms
E177	Ethyl linolenate	Linolenic acid, ethyl ester; Ethyl cis,cis,cis-9,12,15-octadecatrienoate; Ethyl (9Z,12Z,15Z)-9,12,15-octadecatrienoate; Ethyl α -linolenate;ethyl (Z,Z,Z)-9,12,15-octadecatrienoate;9,12,15-Octadecatrienoic acid, ethyl ester, (Z,Z,Z)-
E178	1-Ethyl-4-methoxybenzene	Benzene, 1-ethyl-4-methoxy-; Anisole, p-ethyl-; p-Ethylanisole; 4-Ethylanisole; 1-methoxy-4-ethyl-benzene; p-Ethylanisol
E179	Ethyl (E)-2-methyl-2-pentenoate	2-Pentenoic acid, 2-methyl-, ethyl ester (2E); 2-Pentenoic acid, 2-methyl-, ethyl ester (E); Ethyl (E)-2-methyl-2-pentenoate
E180	Ethyl 4-pentenoate	Ethyl pent-4-enoate; 4-Ethoxycarbonylbut-1-ene;4-Pentenoic acid ethyl ester
E181	1-Ethyl-2-pyrrolecarboxaldehyde	Tea pyrrole;1-Ethyl 1H-Pyrrole-2-carboxaldehyde; 1-Ethyl-2-formylpyrrole; 1H-Pyrrole-2-carboxaldehyde, 1-ethyl-; Pyrrole-2-carboxaldehyde, 1-ethyl-; 1-Ethylpyrrole-2-aldehyde; N-Ethyl-2-formylpyrrole; N-Ethylpyrrole-2-carboxaldehyde
E182	Ethyl pent-2-enoate	
E183	Ethyl 2-phenylpropionate	
E184	1-Ethoxy-1-(2-phenylethoxy)ethane	
E185	Ethyl 2-ethylhexanoate	Ethyl 2-ethylcaproate;Ethyl α -ethylhexanoate;Hexanoic acid, 2-ethyl-, ethyl ester
E186	Ethyl 2-ethylbutyrate	Butanoic acid, 2-ethyl-, ethyl ester;2-Ethyl-n-butyric acid ethyl ester
E187	Ethyl 2-acetoxypropionate	
E188	1-Ethoxy-1-pentyloxybutane	

Order	General Name	Synonyms
E189	2-Ethyl-4-methyl-1,3-dioxolane	1,3-Dioxolane, 2-ethyl-4-methyl-; Propanal, cyclic 1-methyl-1,2-ethanediyl acetal;1,3-Dioxolane, 2-ethyl-4-methyl, cis
E190	1-Ethoxy-4-methoxybenzene	p-Ethoxyanisole; Ethyl p-methoxyphenyl ether;Benzene, 1-ethoxy-4-methoxy-
E191	Ethyl acetoacetate propylene glycol acetal	1,3-Dioxolane-2-acetic acid, 2,4-dimethyl-, ethyl ester;Ethyl 2,4-dimethyl-1,3-dioxolane-2-acetate;ethyl acetoacetate propylene glycol acetal
E192	Ethyl 4-methylpent-3-enoate	
E193	Ethyl 2-methoxybenzoate(Ethyl o-anisate)	o-Anisic acid, ethyl ester; Ethyl o-methoxybenzoate; o-Methoxybenzoic acid, ethyl ester;Benzoic acid, 2-methoxy-, ethyl ester
E194	1-Ethoxy-1-methoxyethane	Acetaldehyde, ethyl methyl acetal;Acetaldehyde methyl ethyl acetyl; 1,1-Ethoxymethoxyethane;Ethane, 1-ethoxy-1-methoxy-
E195	Ethyl 3,7-dimethyl-2,6-octadienoate	
E196	1-Ethoxy-1-pentyloxyethane	Acetaldehyde ethyl amyl acetal; 1-(1-ethoxyethoxy)pentane (acetaldehyde ethylamyl acetal);Pentane, 1-(1-ethoxyethoxy)-
E197	1-Ethoxy-1-isopentyloxyethane	
E198	1-Ethoxy-1-(2-methylbutoxy)ethane	
E199	3-(Ethylthio)propan-1-ol	
E200	5-Ethyl-2-methylthiazole	Thiazole, 5-ethyl-2-methyl-; 5-Ethyl-2-methyl-1,3-thiazole;2-methyl-5-ethylthiazole
E201	δ -Elemene	Cyclohexene, 4-ethenyl-4-methyl-3-(1-methylethenyl)-1-(1-methylethyl)-, (3r-trans)-; p-Menth-3-ene, 2-isopropenyl-1-vinyl-, (1S,2R)-(-)-; 3-Isopropenyl-1-isopropyl-4-methyl-4-vinyl-1-cyclohexene
E202	1-Ethoxy-1-propoxyethane	Acetaldehyde, ethyl propyl acetal;1-(1-Ethoxyethoxy)propane; Ethane, 1-ethoxy-1-propoxy;Propane, 1-(1-

Order	General Name	Synonyms
		ethoxyethoxy)-
E203	(+/-) Ethyl 2-hydroxy-3-methylvalerate	Ethyl 2-ethyl lactate; Pentanoic acid, 2-hydroxy-3-methyl-, ethyl ester (9CI); Valeric acid, 2-hydroxy-3-methyl-, ethyl ester (8CI); 2-Hydroxy-3-methylpentanoic acid ethyl ester; Ethyl 2-hydroxy-3-methylpentanoate
E204	Ethyl 4-methylpentanoate	Ethyl 4-methylvalerate; Ethyl isocaproate; Ethyl isohexanoate; Pentanoic acid, 4-methyl-, ethyl ester; Valeric acid, 4-methyl-, ethyl ester
E205	(+/-) Ethyl 3-hydroxy-2-methylbutyrate	Butanoic acid, 3-hydroxy-2-methyl-, ethyl ester
E206	Ethyl dodec-2-enoate	
E207	Ethyl geranyl ether	
E208	Ethyl pentadecanoate	n-Pentadecanoic acid ethyl ester; Pentadecanoic acid, ethyl ester
E209	Ethyl hept-2-enoate	
E210	1-Ethoxy-1-hexyloxyethane	Acetaldehyde ethyl hexyl acetal; 1-(1-Ethoxyethoxy) hexane; Ethyl hexyl acetal; Hexane, 1-(1-ethoxyethoxy)-
E211	Ethyl 4-hydroxybenzyl ether	
E212	Ethyl dec-9-enoate	Ethyl 9-decenoate
E213	N-[(Ethoxycarbonyl)methyl]-p-menthane-3-carboxamide	[1R-(1 α ,2 β ,5 α)]-N-[[5-Methyl-2-(1-methylethyl)cyclohexyl] carbonyl glycine ethyl ester
E214	cis- and trans-5-Ethyl-4-methyl-2-(2-methylpropyl)-thiazoline	5-ethyl-2,5-dihydro-4-methyl-2-(2-methylpropyl)-thiazole
E215	cis- and trans-5-Ethyl-4-methyl-2-(2-butyl)-thiazoline	5-ethyl-2,5-dihydro-4-methyl-2-(1-methylpropyl)-thiazole
E216	Ethyl 3-acetoxy octanoate	Ethyl 3-(acetoxy)octanoate

Order	General Name	Synonyms
E217	3-(Ethylthio)butanol	
E218	1-Ethoxy-1-(3-methylbutoxy)-3-methylbutane	
E219	1-Ethoxy-2-methyl-1-propoxypropane	
E220	1-Ethoxy-2-methyl-1-isopentyloxypropane	
E221	(+/-)- Ethyl 3-mercapto-2-methylbutanoate	
E222	Ethyl alpha-acetylcinnamate	Ethyl 2-benzylidene-3-oxobutanoate; Butanoic acid, 3-oxo-2-(phenylmethylene)-, ethyl ester
E223	N-Ethyl-2,2-diisopropylbutanamide	N,2-Diethyl-2-(isopropyl)-3-methylbutyramide; Butanamide, N-ethyl-2,2-bis(1-methylethyl)-
E224	Ethyl 2-hydroxy-3- phenylpropionate	Ethyl-2-hydroxy-3-phenylpropanoate; Benzenepropanoic acid, alphahydroxy-, ethyl ester; 3-Phenyllactic acid ethyl ester; Ethyl phenyllactate; Lactic acid, 3-phenyl-, ethyl ester
E225	N-ethyl-5-methyl-2-(1-methylethenyl)cyclohexanecarboxamide	N-Ethyl-5-methyl-2-(prop-1-en-2-yl)cyclohexanecarboxamide
E226	Ethyl 2,5-dimethyl-3-oxo- 4(2H)-furyl carbonate	
E227	(±)-Eriodictyol	(±)-3',4',5,7-tetrahydroxyflavanone; 2-(3,4-Dihydroxyphenyl)-5,7-dihydroxy-2,3-dihydrochromen-4-one; 2-(3,4-Dihydroxyphenyl)-5,7-dihydroxy-4-chromanone
E228	2-Ethoxy-3-ethylpyrazine	3-Ethyl-2-ethoxypyrazine
E229	Ethyl acetoacetate ethyleneglycol acetal	Fructone;Ethylacetoacetate3-ethyleneacetal; Ethyl3-oxobutyrateethyleneketal; 1,3-Dioxolane-2-aceticacid,2-methyl-,ethylester,ethyl2-(2-methyl-1,3-dioxolan-2-yl)acetate
E230	Ethyl 5-acetoxyoctanoate	delta-Acetoxyoctanoic acid, ethyl ester; Octanoic acid, 5-(acetyloxy)-, ethyl ester
E231	Ethyl 2-acetyloctanoate	Ethyl alpha-hexylacetoacetate; Ethyl 2-acetylcaprylate; Octanoic acid, 2-acetyl-, ethyl ester
E232	(2or4)-Ethyl-(4or2),6-dimethyldihydro-1,3,5-dithiazine	2(4)-Ethyl-4(2),6-dimethyldihydro-1,3,5-dithiazinane; Ethyl thialdine

Order	General Name	Synonyms
E233	5-Ethyl-2,3-dimethylpyrazine	2,3-Dimethyl-5-ethyl pyrazine
E234	Ethyl 2-hydroxy-4-methylbenzoate	
E235	Ethyl linalyl ether	3,7-Dimethyl octa-1,6-dien-3-yl ethyl ether; 3,7-Dimethylocta-1,6-dien-3-yl ethyl ether; 3-Ethoxy-3,7-dimethyl-1,6-octadiene; Linalool ethyl ether, 3-Ethoxy-3,7-dimethylocta-1,6-diene
E236	2-Ethyl-2,5-dihydro-4-methylthiazole	2-Ethyl-4-methyl-3-thiazoline; 2-Ethyl-2,5-dihydro-4-methylthiazole; 2-Ethyl-4-methyl-2,5-dihydro-1,3-thiazole
E237	2-Ethyl-3-(methylthio)pyrazine	2-(Methylthio)-3-ethylpyrazine
F001	α -Farnesene	1,3,6,10-Dodecatetraene, 3,7,11-trimethyl (α -isomer)
F002	β -Farnesene	3,7,11-Trimethyl-1,3,6,10-dodecatetraene; 2,6,10-Trimethyl-2,6,9,11-dodecatetrene
F003	Farnesol	2,6,10-Trimethyl-2,6,10-dodecatrien-12-ol; 3,7,11-Trimethyl-2,6,10-dodecatrien-1-ol; 3,7,11- Trimethyldodeca-2,6,10-trien-1-ol; Farnesol
F004	Fenchol	2-Fenchanol; α -Fenchol; 1,3,3-Trimethylbicyclo-2,2,1-heptan-2-ol; 1,3,3-Trimethylbicycloheptan-2-ol
F005	d-Fenchone	d-1,3,3-Trimethyl-2-norcamphanone; 1,3,3-trimethylbicyclo (2.2.1) heptan-2-one; d-2-Fenchanone; fenchone; 1,3,3-Trimethylbicyclo-1,2,2-heptanone-2; d-1,3,3- Trimethyl-2-norbornanone; Fenchone; d-1,3,3-Trimethyl-2-norbornanone; d-1,3,3- Trimehyl-2-norcamphanone; 1,3,3-trimethylbicyclo[2.2.1]heptan-2-one; d-2-fenchanone
F006	Formic acid*	Methanoic acid
F007	2-Formyl-6,6-dimethylbicyclo[3.1.1]hept-2-ene	Myrtenal; benihinal; 2-Formyl-6,6-dimethyl-2-norpinene; 6,6-Dimethyl-2-norpinene- 2-aldehyde; 6,6-Dimethylbicyclo[3.1.1]hept-2-ene-2-carboxaldehyde, 6,6-Dimethyl- 2-norpinene-2-carboxaldehyde, Pin-2-ene-1-carbaldehyde; Pin-2-en-10-al

Order	General Name	Synonyms
F008	Furaneol acetate	4-Acetoxy-2,5-dimethylfuran-3(2H)-one
F009	4-[(2-Furanmethyl)thio]-2-pentanone	4-(Furan-2-ylmethylsulfanyl)pentane-2-one; 4-Furfurylthio-2-pentanone
F010	Furfural	Furfuraldehyde; 2-Furylcarboxaldehyde; fural; 2-Furancarbal; 2-Formylfuran; 2-Furaldehyde; α -Furfuraldehyde; Pyromucic aldehyde; 2-Furancarboxaldehyde
F011	Furfuryl 2-methyl-3-furyl disulfide	3-[(2-Furanylmethyl)dithio]-2-methylfuran; 2-Methyl-3-[(2-furanylmethyl)-dithio]furan; (2-Methyl-3-furyl) furfuryl disulfide; 3-(Furfuryldithio)-2-methylfuran; 2-Methyl-3-furyl 2-furylmethyl disulphide
F012	Furfuryl 3-methylbutanoate	3-Methylbutanoic acid; Furanylmethyl ester; Furfuryl isovalerate
F013	Furfuryl acetate	2-Furanmethanol, acetate; 2-Furyl carbinyl acetate
F014	Furfuryl alcohol	2-Furancarbinol; 2-Furanmethanol; Furfuralcohol; α -Furylcarbinol; 2-Furylcarbinol; 2-Hydroxymethylfuran
F015	Furfuryl butyrate	3-Octanon-1-ol; Methylol methyl amyl ketone; Ketone alcohol; Caproylethanol; 3-Oxo-1-octanol; Hexanoylethanol; 2-Acetyl-1-hexanol; Butanoic acid; 2-Furanylmethyl ester; 2-Furylmethyl butanoate
F016	Furfuryl isopropyl sulfide	Isopropyl furfuryl sulfide; Isopropyl furfuryl sulphide
F017	Furfuryl mercaptan	α -Furfuryl mercaptan; Furfurylidene-2-butanal; 2-Furanmethanethiol; 2-Furyl methanethiol

Order	General Name	Synonyms
F018	Furfuryl methyl ether	Methyl furfuryl ether
F019	Furfuryl methyl sulfide	Methyl furfuryl sulfide
F020	Furfuryl octanoate	α -Furfuryl octanoate; α -Furfuryl caprylate; Octanoic acid; 2-Furanylmethyl ester; 2-furfuryl octanoate
F021	Furfuryl pentanoate	Furfuryl valerate; α -Furfuryl pentanoate; α -Furfuryl valerate; Pentanoic acid; 2-Furanylmethyl ester; α -Furfuryl pentanoate; Furfuryl pentanoate
F022	Furfuryl propionate	Furfuryl propanoate; 2-Furanmethanol propionate
F023	S-Furfuryl thioacetate	furfuryl thioacetate; Furfuryl thiol acetate; S-furfuryl acetothioate
F024	S-Furfuryl thioformate	2-furanmethanethiol formate; Furfurylthiol formate; 2-Furfuryl thioformate
F025	S-Furfuryl thiopropionate	furfuryl thiopropionate; s-Furfuryl propanethioate
F026	2-Furfurylidenebutyraldehyde	2-Ethyl-3-(2-furyl)-2-propenal; 2-Furfurylidenebutanal; 3-(2-furyl)-2-ethyl-2-propenal; 3-(2-furyl)-2-ethylacrolein; Furfurylidene-2-butyraldehyde; 3-Ethyl-3(2-furyl)-2-propenal; 2-Ethyl-3(2-furyl)acrolein
F027	N-Furfurylpyrrole	1-Furfurylpyrrole; 1-(2-Furfuryl)pyrrole; 1-Furfuryl-1H-pyrrole
F028	2-Furyl methyl ketone	2-Acetylfuran; Methyl 2-furyl ketone; Acetylfuran; 2-Furyl methyl ketone
F029	4-(2-Furyl)-3-buten-2-one	4-(2-Furyl)-3-buten-2-one; furfuralacetone; 3-(2-Furyl)acrylaldehyde; 4-(2-Furyl)but-3-en-2-one
F030	3-(2-Furyl)acrolein	Furyl acrolein; (3-(2-furyl) acrolein); 2-Furanmethanethiol; 2-Furanacrolein; 3-(2-Furyl)-2-propen-1-al; 2-Propenal,

Order	General Name	Synonyms
		3-(2-Furanyl)-; 3-(2- Furyl)acrylaldehyde
F031	1-(2-Furyl)butan-3-one	1-(2-Furanyl)-3-butanone; 1-(2-Furyl)-3-butanone; 4-(2-Furyl)-2-butanone; Furfurylacetone; 2-Butanone, 4-(2-furanyl)-; 4-(2- Furyl) butan-2-one
F032	2-Furyl-2-propanone	4-(2-Furyl)but-3-en-2-one; 1-(2- Furyl)-propan-2-one; Furfuryl methyl ketone; 2-Acetonifuran; Furyl acetone; Methyl furfuryl ketone
F033	1-Furyl-2-propanone	furyl acetone
F034	Fusel oil, refined	1-(2-Furyl)-propan-2-one; Amyl alcohol, commercial; (not well defined); Fusel oil, refined (mixed amyl alcohols)
F035	2-Furoic acid	α -Furancarboxylic acid; α -Furoic acid; Pyromucic acid; 2-Carboxyfuran; Furan-2-carboxylic acid; Furancarboxylic acid-(2);2-Furancarboxylic acid
F036	2-Formyl pyrrole	Pyrrole-2-carboxaldehyde; Pyrrole-2-aldehyde; 2-Pyrrolylcarboxaldehyde; α -Pyrrolaldehyde; 2-Pyrrolecarbaldehyde;2-Pyrrolecarboxaldehyde; 1H-Pyrrole-2-carbaldehyde; 1H-pyrrole-2-carboxyaldehyde; 2-carboxaldehyde-1H-pyrrole;H-pyrrole-2-carboxaldehyde;2-Pyrrolcarbaldehyde
F037	Furfural diethyl acetal	Furan, 2-(diethoxymethyl)-; 2-(Diethoxymethyl)furan;2-Furaldehyde diethyl acetal
F038	l-Fenchone	Alpha-fenchone; (1R,4S)-1,3,3-Trimethylbicyclo[2.2.1]heptan-2-one
F039	1-(2-Furfurylthio)-2-propanone	(Furfurylthio)acetone; 1-[(Furan-2-ylmethyl)sulfanyl]propan-2-one
G001	Geranic acid	(E)-2,6-Octadienoic acid, 3,7-dimethyl- ; 3,7- Dimethyl-2(trans),6-octadienoic acid; 3,7-Dimethylocta-2,6-dienoic acid

Order	General Name	Synonyms
G002	Geraniol*	trans-3,7-Dimethyl-2,7-octadien-1-ol; trans-3,7-Dimethyl-2,6-octadien-1-ol; 2,6-Dimethyl-2,6-octadien-8-ol; trans-3,7-Dimethyl-2,7-octadien-1-ol; 2-trans-3,7-Dimethyl-2,6-octadien-1-ol; 3,7-Dimethyl-2,6 and 3,6-octadien-1-ol
G003	Geranyl 2-methylbutyrate	Butanoic acid, 2-methyl-, (2E)-3,7-dimethyl-2,6-octadienyl ester; Butanoic acid, 2-methyl-, 3,7-dimethyl-2,6-octadienyl ester, (E)-; Geranyl 2-methylbutanoate
G004	Geranyl acetate*	Geranyl ethanoate; trans-3,7-dimethyl-2,6-octadien-1-yl ethanoate; trans-3,7-dimethyl-2,6-octadien-1-yl acetate; 2,6-Dimethyl-2,6-octadiene-8-yl acetate; geraniol acetate
G005	Geranyl acetoacetate	trans-3,7-dimethyl-2,6-octadien-1-yl 3-oxobutanoate; trans-3,7-Dimethyl-2,6-octadien-1-yl acetoacetate; Geranyl β -ketobutyrate; Geranyl 3-oxo-butanoate
G006	Geranyl acetone	6,10-Dimethyl-5,9-undecadien-2-one.
G007	Geranyl benzoate	Geraniol benzoate; trans-3,7-Dimethyl-2,6-octadien-1-yl benzoate; 3,7-Dimethylocta-2(trans),6-dienyl benzoate
G008	Geranyl butyrate	trans-3,7-Dimethyl-2,6-octadien-1-yl butanoate
G009	Geranyl formate*	Geranyl methanoate; trans-3,7-Dimethyl-2,6-octadien-1-yl methanoate; trans-3,7-Dimethyl-2,6-octadien-1-yl formate
G010	Geranyl hexanoate	trans-3,7-Dimethyl-2,6-octadien-1-yl hexanoate; Geranyl caproate; geranyl hexylate
G011	Geranyl isobutyrate	Geranyl 2-methylpropanoate; trans-3,7-Dimethyl-2,6-octadien-1-yl 2-methylpropanoate; trans-3,7-Dimethyl-2,6-octadien-1-yl isobutyrate; 3,7-Dimethyl-2,6-octadienyl-2-methyl propanoate; Geranyl 2-methylpropionate

Order	General Name	Synonyms
G012	Geranyl isovalerate	Geranyl isovalerianate; trans-3,7-Dimethyl-2,6-octadien-1-yl 3-methylbutanoate; trans-3,7-dimethyl-2,6-octadien-1-yl isovalerate; trans-3,7-dimethyl-2,6-octadien-1-yl isopentanoate; Geranyl 3-methylbutanoate; Geranyl isopentanoate; 3,7-Dimethyl-2,6-octadienyl-3-methylbutanoate; Geranyl 3-methylbutyrate
G013	Geranyl phenylacetate	trans-3,7-Dimethyl-2,6-octadien-1-yl phenylacetate; Geranyl α -toluate; 3,7-dimethylocta-2(trans),6-dienyl phenylacetate
G014	Geranyl propionate	trans-3,7-Dimethyl-2,6-octadien-1-yl propanoate; Geranyl propanoate; trans-3,7- Dimethyl-2,6-octadien-1-yl propanoate; 2,6-Dimethy octadien-6-yl-8- n-propionate
G015	Geranyl tiglate	2-Butenoic acid, 2-methyl 3,7-dimethyl-2,6-octadienyl ester,(E,E)-; Tiglic acid,3,7- dimethyl-2,6-octadienyl ester; Tiglic acid, geraniol ester
G016	Geranyl valerate	Pentanoic acid, (2E)-3,7-dimethyl-2,6-octadienyl ester; 2,6-Octadien-1-ol, 3,7-dimethyl-, valerate, (E)-; Pentanoic acid, 3,7-dimethyl-2,6-octadienyl ester, (E)-; Valeric acid, 3,7-dimethyl-2,6-octadienyl ester, (E)-; Geraniol valerate; Geranyl pentanoate; 2,6-Dimethyl-2,6-octadiene-8-yl pentanoate
G017	Glucose pentaacetate	1,2,3,4,6-Pentaacetyl- α -d-glucose; β -Phenylacetyl-dextro-glucose; α -Pebtaacetyl-dextro-glucose; 1,2,3,4,6-Pentaacetyl- β -d-glucose; Pentaacetyl glucose; 1,2,3,4,6-pentaacetyl- α - \circ -glucose; 1,2,3,4,6-pentaacetyl- β - \circ -glucose
G018	Glyceryl 5-hydroxydecanoate	Decanoic acid, 5-hydroxy-, Monoester with glycerol; 2,3-Dihydroxypropyl 5-hydroxydecanoate
G019	Glyceryl 5-hydroxydodecanoate	Dodecanoic acid, 5-hydroxy-, Monoester with glycerol; 2,3-Dihydroxypropyl 5-hydroxydodecanoate

Order	General Name	Synonyms
G020	Glyceryl tribenzoate	1,2,3-Propanetriol tribenzoate; Tribenzoin; Propanetri-1,2,3-yl tribenzoate
G021	Glyceryl tripropionate	Propionic acid, triglyceride; Tripropionin; 1,2,3-Tri(propionyloxy)propane
G022	Glycyrrhizin, ammoniated	Glycyrrhizic acid, ammoniated; Glycyrrhizin
G023	Guaiacol	Pyroguaiac acid; 1-Oxy-2-methoxybenzene; o-Methylcatechol; 1-Hydroxy-2-methoxybenzene; 2-Methoxyphenol; o-Hydroxyanisole; o-Methoxyphenol; Methylcatechol; Pyrocatechol monomethyl ether; 1-Oxy-2-methoxybenzene
G024	Guaiacyl acetate	1-Acetoxy-2-methoxybenzene; 2-Methoxyphenyl acetate; acetyl guaiacol; o-Methoxyphenyl acetate; 2-methoxyphenol acetate; o-Acetoxyanisole; Guaiacyl acetate
G025	Guaiacyl phenylacetate	o-Methylcatechol acetate; Guaiacol phenylacetate; o-methoxyphenyl phenylacetate; 2-Methoxyphenyl phenylacetate; o-Methylcatechol phenylacetate; o-methoxyphenyl acetate
G026	Guaiene	1,4-Dimethyl-7-isopropenyl-D9,10-octahydroazulene
G027	Guaiol acetate	1,4-Dimethyl-7-(a-hydroxyisopropyl)-d9,10-octahydroazulene acetate.
G028	Geosmin	4A(2h)-Naphthalenol, octahydro-4,8a-dimethyl-,(4 α ,4 α ,8 α β)-; 4a(2H)-Naphthalenol, octahydro-4,8a-dimethyl-, [4S-(4 α ,4 α ,8 α β)]-; 4a- α -(2H)-Naphthol, octahydro-4- α ,8a- β -dimethyl-; 4,8a-Dimethyloctahydro-4a(2H)-naphthalenol
G029	Germacra-1(10),4(14),5-triene	Germacrene D; 8-Isopropyl-1-methyl-5-methylene-1,6-cyclodecadiene;1,6-Cyclodecadiene, 1-methyl-5-

Order	General Name	Synonyms
		methylene-8-(1-methylethyl)-, [s-(e,e)]-;D-Germacrene
G030	N-Gluconyl ethanolamine	N-(2-Hydroxyethyl)-hexonamide; 2,3,4,5,6-Pentahydroxy-N-(2-hydroxyethyl)-hexanamide; gluconic acid ethanolamine; N-(2-Hydroxyethyl)-gluconamide
G031	N-Gluconyl ethanolamine phosphate	N-(2-Hydroxyethyl)-hexonamide phosphate; 2-[(2,3,4,5,6-pentahydroxyhexanoyl)amino]ethyl dihydrogen phosphate; 2,3,4,5,6-Pentahydroxy-N-(2-hydroxyethyl)hexanamide phosphate; Gluconic acid ethanolamine phosphate
G032	Glyceryl monooleate	Monoolein; 2,3-Dihydroxypropyl 9-octadecanoate
G033	Glyceryl monostearate	Monostearin; alpha-Monostearin; 1-Glyceryl monooctadecanoate; 2,3-Dihydroxypropyl octadecanoate
G034	Glycyrrhizic acid	
H001	cis-3-Hecenyl anthranilate	3-Hexenyl-2-aminobenzoate; (Z)-Hex-3-enyl anthranilate; (Z)-3-Hexenyl anthranilate; Hex-3(cis)-enyl anthranilate; (Z)-Hexenyl 2-aminobenzoate
H002	Hept-2(trans)-enal	trans-2-Heptenal; 3-Butylacrolein; β-Butylacrolein; 2-Heptenic aldehyde; 4-Propylcrotonaldehyde; α,β-heptenoic aldehyde; 2-Heptenal; (E)-2-hepten-1-al; 2-Heptenal; β-Butyl acrolein; Trans-hept-2-en-1-al; 3-Butylacrolein; β-Butylacrolein; Hept-2-enal; Trans-Hept-2-enal
H003	Hept-2-en-1-yl isovalerate	Hept-2-enyl isovalerate; Butanoic acid, 3-methyl-, (E2)-heptenyl ester

Order	General Name	Synonyms
H004	trans-2-trnas-4-Heptadien-1-ol	2,4-Heptadien-1-ol, (2E,4E)-; 2,4-Heptadien-1-ol, (E,E)-; (2E,4E)-Heptadienol; (E,E)-Hepta-2,4-dien-1-ol
H005	(E,E)-2,4-Heptadienal	2,4-Heptadienal; trans,trans-2,4-Heptadienal; Hepta-2,4-dienal
H006	γ-Heptalactone	4-Heptanolide; 5-Propyldihydro-2(3H)-furanone; Hepta-1,4-lactone; Heptanolide-1,4; 4-n-propyl-4-hydroxybutanoic acid lactone; Heptano-1,4-lactone; Heptanolide-(4,1); 4-hydroxyheptanoic acid, γ-lactone; γ-n-Propyl-γ-butyrolactone; γ-Heptalactone; Heptanolide-(4,1); 4-Hydroxyheptanoic acid, γ-Lactone
H007	(+/-)-Heptan-2-yl butyrate	Hept-2-yl butyrate; 2-Heptyl ester; 1-Methylhexyl butyrate; Butanoic acid; 1-Methylhexyl ester
H008	(+/-)-Heptan-3-yl acetate	Hept-3-yl acetate; 1-Ethylpent-1-yl acetate; Acetic acid, 3-Heptyl ester; 1-Ethylpentyl acetate, 3-Heptanol acetate; Hex-3-enyl but-2-enoate
H009	N-(Heptan-4-yl)benzo[D][1,3]dioxole-5-carboxamide	1,3-Benzodioxole-5-carboxamide, N-(1-propylbutyl)-N-(1-propylbutyl)-1,3- benzodioxole-5-carboxamide
H010	Heptanal	Enanthal; oenanthal; Aldehyde C-7; Enanthaldehyde; n-Heptaldehyde; n-Heptyl aldehyde; Heptyl aldehyde; Heptaldehyde; Aldehyde Heptan-1-alc-7
H011	Heptanal dimethyl acetal	Enanthal dimethyl acetal; Oenanthal dimethyl acetal; Heptaldehyde dimethyl acetal; 1,1-Dimethoxy heptane; Aldehyde C-7 dimethyl acetal
H012	Heptanal glyceryl acetal (mixed 1,2 and 1,3 acetals)	2-Hexyl-4-hydroxymethyl-1,3-dioxolan; 2-Hexyl-4-hydroxy-1,3-dioxan; Mixture of 2-hexyl-4-hydroxymethyl-1,3-dioxolane and 2-hexyl-5-hydroxy-1,3-dioxane; 4-Hexyl- 2-hydroxymethyl-1,3-dioxolane; heptaldehyde glyceryl acetal; 2- Hexyl-4- hydroxymethyl-1,3-dioxolan & 2- Hexyl-5-hydroxy-1,3-dioxane; 2-Hexyl-4-hydroxy- 1,3-

Order	General Name	Synonyms
		dioxane
H013	2,3-Heptanedione	Acetyl pentanoyl; Acetyl valeryl; Valeryl acetyl
H014	2-Heptanethiol	(+/-)-2-Heptanethiol
H015	Heptanoic acid	n-Heptylic acid; Oenanthic acid; Heptoic acid; Oenanthylic acid; Enanthic acid; n-Heptanoic; Enanthic; n-Heptanoic acid
H016	2-Heptanol	2-Hydroxyheptane; <i>n</i> -amyl methyl carbinol; <i>sec</i> -heptyl alcohol; Amyl methyl carbinol; Methyl amyl carbinol
H017	3-Heptanol	Butyl ethyl carbinol; Ethyl butyl carbinol; n-Butyl ethyl carbinol
H018	2-Heptanone	Amyl methyl ketone; ketone C-7; Methyl amyl ketone; Heptan-2-one; Amyl methyl ketone
H019	3-Heptanone	Butyl ethyl ketone; Ethyl butyl ketone; Ethyl- <i>n</i> -butyl ketone
H020	4-Heptanone	Butyrone; dipropyl ketone
H021	(Z)-4-Hepten-1-ol	Cis-4-heptenol; 4-(Z)-heptenol
H022	3-Hepten-2-one	n-Butylideneacetone; 1-Acetyl-1-pentene; Butylidene acetone; Methyl pentenyl ketone; Hept-3-en-2-one
H023	(+/-)-1-Hepten-3-ol	Hept-1-en-3-ol; Butyl vinyl carbinol; 1- Hepten-3-ol

Order	General Name	Synonyms
H024	2-Hepten-4-one	Propenyl propyl ketone; Ethyl ethylidene acetone; 1-Butyryl propylene; Hept-2-en-4-one
H025	cis-4-Heptenal	(Z)-hept-4-en-1-al; 4-Hepten-1-al; n-Propylidene butyraldehyde; Cis-4-hepten-1-al; Hept-4-enal; Cis-4-Ethylidene butyraldehyde
H026	trans-4-Heptenal	trans Hept-4-enal; 4-Hepten-1-al; n-Propylidene butyraldehyde
H027	4-Heptenal diethyl acetal	1,1-Diethoxyhept-4-ene (cis and trans); 1,1-Diethoxy-4-heptene
H028	(E)-2-Heptenoic acid	trans-2-Heptenoic acid
H029	trans-3-Heptenyl 2-methylpropanoate	<i>trans</i> -3-Heptenyl isobutyrate; Hept-3(trans)-enyl isobutyrate
H030	trans-3-Heptenyl acetate	Hept-3(trans)-enyl acetate; 3-Hepten-1-ol, acetate
H031	Hept-trans-2-en-1-yl acetate	2-Hepten-1-ol, acetate, (2E)-; 2-Hepten-1-ol, acetate, (E)-; (E)-2-Heptenyl acetate; trans-2-Heptenyl acetate
H032	Heptyl acetate	Heptyl ethanoate; Acetate C-7; Heptanyl acetate
H033	Heptyl alcohol	1-Heptyl alcohol; Hexyl carbinol; Alcohol C-7; Enanthic alcohol; 1-Heptanol; Hydroxy heptane; Heptan-1-ol; Enanthyl alcohol
H034	Heptyl butyrate	Heptyl butanoate; n-Heptyl-n-butanoate; n-heptyl-n-butyrate
H035	Heptyl cinnamate	Heptyl- β -phenylacrylate; heptyl-3-phenyl propenoate
H036	Heptyl formate	Heptyl methanoate ; n-Heptyl methanoate
H037	Heptyl isobutyrate	<i>n</i> -Heptyl dimethylacetate; <i>n</i> -Heptyl isobutanoate; n-Heptyl-2-methylpropanoate
H038	Heptyl octanoate	Heptyl caprylate; Heptyl octylate; n-Heptyl octanoate

Order	General Name	Synonyms
H039	cis- and trans-2-Heptylcyclopropanecarboxylic acid	Cyclopropanecarboxylic acid, 2-heptyl-
H040	3-Heptyldihydro-5-methyl-2(3H)-furanone	3-Heptyl-4-pentanolide; α -n-Heptyl- γ -valerolactone; 3-Heptyl-5-methyl-2(3H)-furanone; α -Heptyl- γ -valerolactone; α -n-Heptyl-8-valerolactone;
H041	2-Heptylfuran	1-(2-Furyl)-heptane
H042	Hex-2-enyl acetate	2-Hexen-1-yl acetate; 2-hexenyl ethanoate; Hex-2-enyl acetate
H043	Hex-3(trans)-enal	
H044	1-Hexadecanol	Alcohol C-16; Cetyl alcohol; Palmityl alcohol; Hexadecan-1-ol; n-Hexadecyl alcohol
H045	omega-6-Hexadecenlactone	6-Hexadecenolide; Oxacycloheptadec-7-en-2-one; Hexadec-6-eno-1,16-lactone; Ambrettolide; Hexadec-6-eno-1,16-lactone; Cyclohexadecen-7-olide; 16-Hydroxy-6-hexadecenoic acid, w-lactone; 16-hydroxy- Δ 7-hexadecenoic acid, lactone; hexadec-7-en-1,16-lactone; omega-6-hexadecenlactone; 16-Hydroxy-7-hexadecenoic acid lactone; 6-Hexadecenolide
H046	2,4-Hexadien-1-ol	1-Hydroxy-2,4-hexadiene, Sorbic alcohol, Sorbyl alcohol; Hexa-2,4-dien-1-ol
H047	(E,E)-2,4-Hexadienal	trans, trans-2,4-hexadienal; 2-Propylene acrolein; Hexa-2(trans),4(trans)-dienal; Sorbic aldehyde; Hexa-2(trans),4(trans)-dienal; Hexa-2,4-dienal
H048	(E,E)-2,4-Hexadienoic acid	(E,E)-2,4-Hexadienoic acid, Panosorb, (E,E)-1,3-Pentadiene-1-carboxylic acid, Sorbistat; Sorbic acid; Hexa-2,4-dienoic acid
H049	2,4-Hexadienyl acetate	Sorbyl acetate; 2,4-Hexadien-1-ol, acetate

Order	General Name	Synonyms
H050	2,4-Hexadienyl butyrate	Sorbyl butyrate; Butanoic acid, 2,4-Hexadienyl ester
H051	2,4-Hexadienyl isobutyrate	Sorbyl isobutyrate; Propanoic acid, 2-Methyl-, 2,4-Hexadienyl ester
H052	2,4-Hexadienyl propionate	Sorbyl propionate; 2,4-Hexadien-1-ol, propanoate
H053	1,6-Hexalactam	epsilon-Caprolactam; omega-Caprolactam; 1-Aza-2-cycloheptanone; 2-Azacycloheptanone; 2-Ketohexamethylenimine; 2-Oxohexamethylenimine; 2-Perhydrazepinone; 6-Caprolactam; 6-Hexanelactam; Aminocaproic lactam; Azepan-2-one; Caprolactam; Hexahydro-2-azepinone; Hexahydro-2H-azepin-2-one; Hexano-6-lactam; Hexanoic acid, 6-amino-, cyclic lactam; Hexanolactam
H054	γ-Hexalactone	4-Hexanolide; 5-Ethyldihydro-2(3H)-furanone; 4-Hydroxyhexanoic acid lactone; hexa-1,4-lactone; Ethyl butyrolactone; 4-Ethyl-4-hydroxybutanoic acid lactone; γ-Ethyl-γ-butyrolactone; Hexano-1,4-lactone; γ-Caprolactone; ethyl butyrolactone; γ-Ethyl-n-butyrolactone; Hexanolide-1,4; 4-Hydroxyhexanoic acid γ-lactone; Tonkalide; γ-Hexalactone
H055	delta-Hexalactone	5-Hexanolide; 6-Methyltetrahydro-2-pyrone; 5-Hydroxyhexanoic acid lactone; 5-Hydroxyhexanoic acid lactone; 5-Methyl-5-hydroxypentanoic acid lactone; 5-Methyl-δ-valerolactone; Hexano-1,5-lactone; 5-Hydroxyhexanoic acid, δ-lactone; δ-Caprolactone; Tetrahydro-6-methyl-2H-pyran-2-one; delta-Hexalactone; 5-Methyl-d-valerolactone
H056	Hexanal	Hexaldehyde; Caproaldehyde; Aldehyde C-6; n-Caproaldehyde; Caproic aldehyde; Hexoic aldehyde; n-Hexaldehyde

Order	General Name	Synonyms
H057	2,3-Hexanedione	Butyryl acetyl; Acetyl butyryl; Acetyl-n-butyryl; Methyl propyl diketone
H058	3,4-Hexanedione	Diethyl diketone; Dipropionyl; 3,4-Dioxohexane; Diethyl- α , β -diketone
H059	1,6-Hexanedithiol	1,6-Dimercaptohexane; Hexamethylene dimercaptan
H060	1-Hexanethiol	Hexyl mercaptan
H061	Hexanoic acid	<i>n</i> -Caproic acid; hexoic acid; <i>n</i> -Hexylic acid; Pentane-1-carboxylic acid; Caproic acid; 2-Butylacetic acid; Pentylformic acid
H062	3-Hexanol	Ethyl propyl carbinol; 3-Hydroxyhexane
H063	3-Hexanone	Ethyl propyl ketone; 3-Oxohexane
H064	2-Hexen-1-ol	2-Hexenol; <i>trans</i> -2-hexenol; α , β -Hexenol; Leaf alcohol; γ -Propyl allyl alcohol; Hex-2(<i>trans</i>)-en-1-ol; 3-Propylallyl alcohol; <i>Trans</i> -2-hexen-1-ol; <i>trans</i> -2-Hexen-1-ol
H065	<i>cis</i> -3-Hexen-1-ol	3-Hexen-1-ol; (<i>Z</i>)-hex-3-enol; Green leaf alcohol; Leaf alcohol; Blatter alcohol; <i>cis</i> -3-hexenol; β , γ -Hexenol; Hex-3(<i>cis</i>)-en-1-ol; Blatteralkohol; Hex-3-en-1-ol; Hex-3(<i>trans</i>)-en-1-ol
H066	4-Hexen-1-ol	Hex-4-en-1-ol; 2-Hexen-ol-6; 4-Hexenyl alcohol

Order	General Name	Synonyms
H067	2-Hexen-1-yl acetate	
H068	1-Hexen-3-ol	Vinyl propyl carbinol; 1-Vinylbutan-1-ol; Vinyl butan-1-ol; Propyl vinyl carbinol
H069	4-Hexen-3-one	2-Hexen-4-one; 2-Hexen-2-one; Hex-2-en-4-one; Propylene ethyl ketone
H070	2-Hexenal	Hexen-2-al; β -propylacrolein; Leaf aldehyde; trans-2-Hexenal; trans-2-Hexen-1-al; β -Propylacrolein; trans-hex-2-enal
H071	cis-3-Hexenal	3-Hexenal, (Z)-; cis- β,γ -Hexylenic aldehyde; Hex-3-enal
H072	cis-4-Hexenal	4-Hexenal, (Z)-; Hex-4-enal
H073	3-Hexenal	
H074	trans-4-Hexenal	(E)-4-Hexenal; trans-Hex-4-enal
H075	(E)-2-Hexenal diethyl acetal	2-Hexene,1,1-diethoxy-,(2E)-
H076	trans-2-Hexenoic acid	β -Propylacrylic acid; 3-Propylacrylic acid; Acrylic, β -propyl acid; Hexen-2-oic acid; α,β -Hexylenic acid; α,β -Hexenoic acid; Hex-2(trans)-enoic acid
H077	3-Hexenoic acid	3-Hexenic acid; hydrosorbic acid; β -Amylene- α -carboxylic acid; 2-Pentene-1- carboxylic acid; Propylidenepropionic acid
H078	cis-2-Hexenol	(Z)-3-Hexen-1-ol; (Z)-2-Hexenol; 2-Hexen-1-ol; Hex-2(cis)-en-1-ol; 2- Hexenol
H079	(Z)-3-Hexenyl (E)-2-butenate	2-Butanoic acid, 3-hexenyl ester; (E,Z)-Crotonate de (Z)-3-hexenyle; (Z)-3-Hexenyl crotenate; (Z)-2-Butenoic acid 3-hexenyl ester; cis-3-Hexenyl trans-2-butenate; Hex-3-enyl but-2-enoate

Order	General Name	Synonyms
H080	3-Hexenyl 2-hexenoate	(Z)-Hexenyl(E)-2-Hexenoate; 2-Hexenoic acid, 3-hexenyl ester,(E,Z); 2-Hexenoic acid, (E), 3-hexenyl ester,(Z); cis-3-Hexenyl trans-2-hexenoate; Hex-3-enyl hex-2-enoate
H081	3-Hexenyl 2-methylbutanoate	3-Hexenyl 2-methylbutyrate; cis-3-Hexenyl- α -methylbutyrate ; Hex-3-enyl 2-methylbutyrate; Hex-3-enyl 2-methylbutanoate
H082	3-Hexenyl 3-methylbutanoate	3-Hexenyl 3-isovalerate; 3-Hexenyl isopentanoate; 3-Hexenyl isovalerate; cis-3-hexenyl isovalerate; Hex-3-enyl isovalerate
H083	cis-3-Hexenyl acetate	<i>cis</i> -3-Hexen-1-yl acetate; cis-3-Hexenyl ethanoate; Hex-3(cis)-enyl acetate
H084	cis-3-Hexenyl benzoate	Hex-3-enyl benzoate; 3-Hexen-1-ol, benzoate, (Z); (Z)-3-hexenyl benzoate
H085	cis-3-Hexenyl butyrate	Hex-3-enyl butyrate; β,γ -Hexenyl-n-butyrate; cis-3-Hexenyl butanoate; Leaf butyrate
H086	trans-2-Hexenyl butyrate	(E)-2-Hexenyl butyrate; Butanoic acid, 2-hexenyl ester; trans-2-Hexenyl butanoate; Hex-2-enyl butyrate
H087	cis-3-Hexenyl cis-3-hexenoate	Hex-3-enyl hex-3-enoate; 3-Hexenoic acid, 3-hexenyl ester, (Z,Z)-; (Z)-3-Hexenyl (Z)-3-hexenoate
H088	cis-3-Hexenyl formate	3-Hexenyl methanoate; Hex-3(cis)-enyl formate; β,γ -Hexenyl methanoate; (Z)-3-hexenol formate; Leaf alcohol formate
H089	trans-3-Hexenyl formate	
H090	trans-2-Hexenyl formate	Hexen-1-ol, formate,(E)-(E)-Hex-2-enyl formate; Hex-2-enyl formate; (E)-Hex-2-enyl formate

Order	General Name	Synonyms
H091	3-Hexenyl formate (cis and trans mixture)	
H092	cis-3-Hexenyl hexanoate	Hex-3-enyl hexanoate; β,γ -Hexenyl hexoate; cis-3-Hexenyl caproate; Leaf caproate; cis-3-hexen-1-ol hexenoate; 3-Hexenyl caproate
H093	(E)-2-Hexenyl hexanoate	Hexanoic acid, (2E)-2-hexenyl ester; trans-2-Hexenyl caproate; trans-2-Hexenyl hexanoate
H094	cis-Hexenyl isobutyrate	(Z)-3-Hexenyl isobutyrate; (Z)-Hex-3-enyl isobutyrate; 3-Hexenyl 2-methylpropionate; cis-3-Hexenyl isobutyrate; Hex-3(cis)-enyl isobutyrate; β,γ -Hexenyl isobutanoate
H095	(E)-2-Hexenyl isovalerate	Butanoic acid, 3-methyl-, 2-hexenyl ester,(E); (E)-Hex-2-enyl isovalerate; trans-2-Hexenyl isovalerate; Hex-2-enyl isovalerate
H096	cis-3-Hexenyl lactate	Hex-3-enyl lactate; cis-3-Hexenyl 2-hydroxypropanoate; (Z)-3-hexenyl lactate; propanoic acid, 2-hydroxy-, 3-hexenyl ester, (Z)-; Leaf lactate
H097	2-Hexenyl octanoate	Octanoic acid, 2-hexenyl ester, (E)-
H098	3-Hexenyl phenylacetate	Benzeneacetic acid, 3-hexenyl ester, (Z)-; cis-3-Hexenyl phenyl acetate; 3-Hexenyl α -toluate; β,τ -hexenyl o-toluate; β,γ -Hexenyl α -toluate; Hex-3(cis)-enyl phenylacetate
H099	cis-3- and trans-2-Hexenyl propionate	(Z)-3 and (E)-2-Hexenyl propionate; Green note propionate; cis-1-3, trans-2-Hexenyl propionate; Propanoic acid, cis-3, trans-2-hexenyl ester
H100	cis-3 and trans-2-Hexenyl propionate	(E)-2-Hexenyl propionate; 2-Hexen-1-ol, propionate,(E); (E)-Hex-2-enyl propionate; 2-Hexenyl propanoate; trans-2-Hexenyl propionate
H101	cis-Hexenyl propionate	2-Hexen-1-ol, propanoate, (E); (E)-Hex-2-enyl-propionate; trans-2-Hexenyl propionate; (Z)-3-hexenyl propionate; Hex-3(cis)-enyl propionate; β,γ -Hexenyl propanoate

Order	General Name	Synonyms
H102	cis-3-Hexenyl pyruvate	(Z)-3-Hexenyl pyruvate; Propanoic acid, 3-oxo-, 3-hexenyl ester,(Z); Hex-3-enyl 2-oxopropionate; Hex-3-enyl pyruvate
H103	cis-Hexenyl tiglate	(Z)-3-Hexenyl(E)-2-methyl-2-butenolate; (Z)-3-hexenyl2-methylcrotonate; cis-3-Hexenyl α -methylcrotonate; cis-3-Hexenyl trans-2-methyl-2-butenolate; cis-3-Hexenyl tiglate; Hex-3(cis)-enyl 2-methylcrotonate; cis-3-Hexenyl-2-methyl- trans-2-butenolate
H104	(E)-2-Hexenyl valerate	trans-2-Hexenyl pentanoate; (E)-Hex-2-enyl valerate; Pentanoic acid, 2-hexenyl ester,(E)
H105	cis-Hexenyl valerate	(Z)-3-Hexenyl valerate; cis-3-Hexenyl pentanoate; (Z)-Hex-3-enyl valerate; Valeric acid, 3-hexenyl ester,(Z); cis-3-Hexenyl valerate; Hex-3-enyl valerate
H106	n-Hexyl 2-butenolate	Hexyl crotonate; Hexyl 2-butenolate
H107	Hexyl 2-furoate	2-Furancarboxylic acid, hexyl ester; 2-Furoic acid; Hexyl furan-2-carboxylate
H108	Hexyl 2-methyl-3- and 4-pentenoate (mixture)	Hexyl-2-methylpent-(3 and 4)-enoate
H109	Hexyl 2-methylbutyrate	hexyl 2-methylbutanoate
H110	Hexyl 3-mercaptopbutanoate	Butanoic acid, 3-mercapto-, Hexyl ester; 3-Mercaptopbutanoic acid hexyl ester
H111	Hexyl 3-methylbutanoate	Hexyl isovalerate; hexyl isopentanoate; Hexyl isovalerianate
H112	Hexyl acetate	Hexyl ethanoate; 1-Acetoxy-hexane

Order	General Name	Synonyms
H113	Hexyl alcohol	Caproic alcohol; Alcohol C-6; 1-Hexanol; Hexan-1-ol; n-Hexyl alcohol; Amyl carbinol; n-Hexanol
H114	Hexyl benzoate	Benzoic acid, hexyl ester; Agrumat; n-Hexyl benzenecarboxylate; n-Hexyl benzoate; Hexyl phenyl methanoate
H115	Hexyl butyrate	Hexyl butanoate; n-Hexyl n-butanoate
H116	Hexyl formate	Hexyl methanoate; n-Hexyl formate; Formic acid hexyl ester
H117	Hexyl hexanoate	Hexyl caproate; Hexyl capronate; hexyl hexylate
H118	Hexyl isobutyrate	Hexyl 2-methylpropanoate
H119	Hexyl octanoate	Hexyl caprylate; <i>n</i> -Hexyl- <i>n</i> -octanoate; <i>n</i> -Hexyl- <i>n</i> -octoate; <i>n</i> -Hexyl octylate; Hexyl octylate
H120	Hexyl phenylacetate	Phenylacetic acid, hexyl ester; Henzeneacetic acid, hexyl ester; Hexyl α -toluate; n-hexyl phenylacetate
H121	Hexyl propionate	n-Hexyl propanoate
H122	Hexyl trans-2-hexenoate	Hexyl 2-hexenoate; 2-Hexenoic acid, hexyl ester, (E)-; Hexyl (E)-2-hexenoate
H123	2-Hexyl-4,5-dimethyl-1,3-dioxolane	Heptanal2,3-butandiol acetal
H124	2-Hexyl-4-acetoxytetrahydrofuran	
H125	2-Hexyl-5 or 6-keto-1,4-dioxane	5-Hexyl-1,4-dioxan-2-one
H126	Hexylamine	1-Aminohexane; 1-Hexylamine; Mono-n-hexylamine; n-Hexylamine
H127	α -Hexylcinnamaldehyde	α -n-Hexylcinnamic aldehyde; Jasmonal h; 2-Benzylidene-octanal; α -n-Hexyl- β - phenyl acrolein; Hexyl cinnamic aldehyde; 1-(phenylmethylene)cotanal
H128	2-Hexylidene cyclopentanone	Cyclopentanone, 2-hexylidene-; α -Hexylidene cyclopentanone; Jasmalone; 2- Hexylidenecyclopentan-1-one

Order	General Name	Synonyms
H129	2-Hexylthiophene	Thiophene, 2-hexyl-
H130	(-)-Homoeriodictyol, sodium salt	4H-1-Benzopyran-4-one, 2,3-dihydro-5,7-dihydroxy-2-(4-hydroxy-3-methoxyphenyl)-, sodium salt; (+,-)-5,7,4 - Trihydroxy-3 -methoxyflavanone, sodium salt; (+,-)-Homoeriodictyol sodium salt
H131	2-(2-Hydroxy-4-methyl-3-cyclohexenyl) propionic acid γ -lactone	Wine lactone; 2(3H)-Benzofuranone, 3a,4,5,7a-tetrahydro-3,6-dimethyl; 3a,4,5,7a-Tetrahydro-3,6-dimethylbenzofuran-2(3H)-one
H132	Hydratropic aldehyde	2-Phenylpropanal; Hydratropaldehyde; α -Methyltolualdehyde; α -Methylphenyl- acetaldehyde; α -Phenylpropionaldehyde; 2-Phenylpropionaldehyde; 2-Phenylpropanal; 2-Phenylpropionald
H133	Hydratropic aldehyde dimethyl acetal	1,1-Dimethoxy-2-phenylpropane; 2-Phenylpropionaldehyde dimethyl acetal; Phenylpropanal dimethyl acetal
H134	Hydrogen sulfide	Hydrosulfuric acid
H135	Hydroquinone monoethyl ether	1-Ethoxy-4-hydroxybenzene; p-Ethoxyphenol; 4-Ethoxyphenol; p-Hydroxyphenetole
H136	4-Hydroxy-2,3-dimethyl-2,4-nonadien	4-Hydroxy-2,3-dimethyl-2,4-nonadienoic acid γ lactone; Bovolide; 2(5H)-Furanone, 3,4-dimethyl-5-pentylidene-; 3,4-Dimethyl-5-pentylidene-5H-furan-2-one; 5-Pentylidene-3,4-dimethyl-2,5-dihydrofuran-2-one; 4-Hydroxy-2,3-dimethyl-2,4- nonadienoic acid γ lactone
H137	5-Hydroxy-2,4-decadienoic acid delta-lactone	2,4-Decadien-5-olide; pentyl- α -pyrone; 6-Pentyl-2H-pyran-2-one; 6-Pentyl- α - pyrone; 2H-pyran-2-one, 6-pentyl-; 5-Hydroxy-2,4-decadienoic acid lactone; 6-amyl- α -pyrone
H138	4-Hydroxy-2,5-dimethyl-3(2H)-furanon	4-Hydroxy-2,5-dimethylfuran-3(2H)-one; 2,5-Dimethyl-4-hydroxy-3(2H)furanone; fleureol(Fleurchem); Fraison(Vioryl); Furanone pure crystals; Strawberry furanone; Furaneol; 2,5-Dimethyl-4-hydroxy-2,3-dihydrofuran-3-one

Order	General Name	Synonyms
H139	1-Hydroxy-2-butanone	2-Oxo-1-butanol; propionyl carbinol; Ethyl hydroxymethyl ketone; 1-Butanol-2-one
H140	4-Hydroxy-2-butenic acid γ -lactone	2(5H)-Furanone; Crotonic acid, 4-hydroxy-, γ -lactone; α , β -Crotonolactone; delta, α , β -Butenolide; γ -Crotolactone; γ -Crotonolactone; γ -Hydroxycrotonic acid lactone; 2,5-Dihydrofuranone; 2-Buten-4-olide; 2-Butenoic acid, 4-hydroxy-, γ -lactone; 2-Oxo-2,5-dihydrofuran; 4-Hydroxy-2-butenic acid lactone; 5-Oxo-2,5-dihydrofuran-3-yl ester; 5H-Furan-2-one; Cratone; Isocrotonolactone
H141	2-Hydroxy-2-cyclohexen-1-one	3-Methyl-1,2-cyclohexanedione; 2-Methyl-3,4-cyclohexanedione; 1,2-Cyclohexanedione; 2-cyclohexen-1-one, 2-hydroxy-; Cyclohexane-1,2-dione
H142	5-Hydroxy-2-decenoic acid delta-lactone, 5-hydroxy-2-dodecenoic acid delta-lactone and 5-tetradecenoic acid delta-lactone, mixture of	
H143	5-Hydroxy-2-decenoic acid δ -lactone	2-decen-5olide; 6-pentyl-5,6-dihydro-2-pyrone; 2-decene-1,5-lactone; Dec-2-eno- 1,5-lactone; (-)-2-Decenoic acid, 5-hydroxy, δ -lactone; 5,6-Dihydro-6- pentyl- 2H- pyran-2-one; (R)-5,6-dihydro-6-pentyl-2H-pyran-2-one; Massoia lactone; Massoi lactone; 2H-pyran-2-one, 5,6-dihydro-6-pentyl-, (R)-; 5-Hydroxy-2-decenoic acid lactone
H144	5-Hydroxy-2-dodecenoic acid delta-lactone	Dodec-2-eno-1,5-lactone; 2-Dodecen-5-olide; 6-Heptyl-2h-dihydro-2-pyrone; 6-heptyl-5,6-dihydro(2H)pyran-2-one; 5-Hydroxy-2-dodecenoic acid lactone; Delta-2-dodecenolactone; 6-Heptyl-5,6-dihydro-2-pyrone; 5-Heptyl-2-pentene-5-olide
H145	3-Hydroxy-2-octanone	2-Octanone, 3-hydroxy-

Order	General Name	Synonyms
H146	3-Hydroxy-2-oxopropionic acid	Propanoic acid, 3-hydroxy-2-oxo-; 3-Hydroxy-2-oxopropionic acid
H147	3-Hydroxy-2-pentanone	Acetyl ethyl carbinol; 2-Pentanone, 3-hydroxy-; 3- Hydroxypentan-2-one; Acetyl ethyl carbonol
H148	2-Hydroxy-3,5,5-trimethyl-2-cyclohexen-1-one	2-Hydroxy-3,5,5-trimethyl-2-cyclohexenone; 3,5,5-trimethyl-1,2-cyclohexanedione; 2-Cyclohexen-1-one, 2-hydroxy-3,5,5-trimethyl-; 3,5,5-Trimethyl-1,2-cyclohexanedione
H149	4-Hydroxy-3,5-dimethoxybenzaldehyde	Syringic aldehyde; Syringaldehyde; Gallaldehyde 3,5-dimethyl ether
H150	6-Hydroxy-3,7-dimethyloctanoic acid lactone	3,7-dimethyl-6-octanolide; 4-methyl-7-(1-methylethyl)-2-oxooxacycloheptane; 3,7-dimethylocta-1,6-lactone; Menthone lactone; 3,7-Dimethyloctano-1,6-lactone; 6-Hydroxy-3,7-dimethyl caprylic acid, lactone; 4-Methyl-7-isopropyl-2-oxoeapanone; Menthane lactone
H151	4-Hydroxy-3-methoxybenzoic acid	Vanillic acid; 4-Hydroxy-m-anisic acid
H152	N-(4-Hydroxy-3-methoxybenzyl) nonanamide	Nonanoyl 4-hydroxy-3-methoxybenzylamide; n-Nonanoyl vanillylamide; Pelargonyl vanillylamide; N-Nonanoyl 4-hydroxy-3-methoxybenzylamide; Nonivamide; vanillylnonanamide; N-(4-Hydroxy-3-methoxybenzyl)nonanamide
H153	4-Hydroxy-3-methyloctanoic acid γ -lactone	Whiskey lactone; 3-Methyloctano-1,4-lactone; 3-Methyl-4-octanolide; 5-butyl-4-methyldihydro-2(3h)-furanone; 4-Hydroxy-3-methyloctanoic acid lactone; methyl octalactone; β -Methyl- γ -octalactone; 4-Butyl-3-methyl-1,4-butyrolactone; 5-butyldihydro-4-methylfuran-2(3H)-one
H154	4-Hydroxy-3-pentenoic acid lactone	α -Angelica lactone; 3-penten-4-olide; Pent-3-en-1,4-lactone; 5-Methyl-2(3H)- furanone; 5- Methylfuran-2(3H)-one; 4-Hydroxy-3-pentenoic acid lactone; β - γ -Angelica lactone; γ -Methyl β -butenolide

Order	General Name	Synonyms
H155	4-Hydroxy-4-methyl-5-hexenoic acid γ lactone	Lilac lactine; 2(3H)-Furanone, 5-ethenyldihydro-5-methyl-; 5-Methyl-5-viyl- dihydrofuran-2-one; 4-Methyl-5-hexen-1,4-olide; 4-Hydroxy-4-methyl-5-hexenoic acid
H156	4-Hydroxy-4-methyl-7-cis-decenoic acid γ lactone	2(3H)-Furanone, 5-(3-Hexenyl)dihydro-5-methyl-, (Z); (Z)-5-Hex-3-enyldihydro- 5-methylfuran-2(3H)-one; Lactone of cis Jasmine; 4-Methyl-cis-7-decene γ -lactone; cis-5-Hexenyldihydro-5-methylfuran-2(3H)-one; 4-Hydroxy-4-methyldec-9-enoic acid lactone
H157	2-Hydroxy-4-methylbenzaldehyde	2,4-Cresotaldehyde; 4-Methylsalicylic aldehyde; 4-Methylsalicylaldehyde
H158	5-Hydroxy-4-methylhexanoic acid delta-lactone	2H-Pyran-2-one,tetrahydro-5,6-dimethyl-; Hexanoic acid, 5-hydroxyl-4-methyl-, delta-lactone; 4-Methyl-5-hydroxyhexanoic acid lactone; 5,6-Dimethyltetra- hydrofuran-2-one
H159	5-Hydroxy-4-octanone	5-Hydroxyoctan-4-one; Butyrolin; 5-Octanol-4-one; Butyrolin
H160	3-Hydroxy-4-phenylbutan-2-one	2-Butanone, 3-hydroxy-4-phenyl-
H161	3(2)-Hydroxy-5-methyl-2(3)-hexanone	
H162	1-(3-Hydroxy-5-methyl-2-thienyl)ethanone	Ethanone, 1-(3-hydroxy-5-methyl-2-thienyl)
H163	4-Hydroxy-5-methyl-3(2H)-furanone	3(2H)-Furanone, 4-hydroxy-5-methyl-; 4-Hydroxy-5-methyl-2,3-dihydrofuran-3-one; 5-Methyl-4-hydroxy-3(2H)-furanone; 2,3-Dihydro-4-hydroxy-5-methylfuran-3-one

Order	General Name	Synonyms
H164	cis-4-Hydroxy-6-dodecenoic acid lactone	(E)-6-dodecen-4-olide; 5-(cis-2octenyl)dihydro-2(3H)-furanone; (Z)-4-hydroxy-6- dodecenoic acid lactone; Dodec-6-eno-1,4-lactone; γ -Dodecen-6-lactone; 1,4-Dodec- 6-enolactone; cis-6-dodecen-4-olide; 2(3H)-furanone, dihydro-5(2-octenyl), (Z)-; cis-dihydro-5-(2-octenyl)-2(3H)furanone; 4-Hydroxy-6-dodecenoic acid lactone; Dihydro-5(2-octenyl)-2(3H)-furanone
H165	5-Hydroxy-7-decenoic acid δ -lactone	7-Decen-5-olide; 6-Pentyltetrahydro-2-pyrone; 7-decene-1,5-lactone; Dec-7- eno-1,5-lactone; Jasmine lactone; cis-5-(2-Pentenyl)pentanolide; 2H-pyran-2-one, tetrahydro-6-(2-pentenyl)-, Z; 5-Hydroxy-7-decenoic acid lactone
H166	5-Hydroxy-8-undecenoic acid delta-lactone	8-Undecen-5-olide; 6-Hexyltetrahydro-2-pyrone; Undec-8-eno-1,5-lactone; 2H-pyran-2-one, 6-(3-hexenyl)tetrahydro-, (Z)-; 5-Hydroxy-8-undecenoic acid lactone; cis-6-(3-Hexenyl)tetrahydro(2H)pyran-2-one; 5-Hydroxyundec-8-enoic acid deltalactone; 6-(3-Hexenyl)tetrahydro(2H)pyran-2-one
H167	2-Hydroxyacetophenone	<i>o</i> -Acetylphenol; ethanone, 1-(2-hydroxyphenyl)-; <i>o</i> -hydroxyacetophenone; 2'-Hydroxyacetophenone
H168	4-Hydroxybenzaldehyde	<i>p</i> -Oxybenzaldehyde; 4-Formylphenol; <i>p</i> -Formylphenol; <i>p</i> -Hydroxybenzaldehyde
H169	2-Hydroxybenzoic acid	2-Carboxy phenol; 2-Hydroxybenzene carboxylic acid; Salicylic acid; <i>o</i> -Hydroxybenzoic acid
H170	4-Hydroxybenzoic acid	4-Carboxyphenol; <i>p</i> -Hydroxybenzoic acid; <i>p</i> -salicylic acid

Order	General Name	Synonyms
H171	4-Hydroxybenzyl alcohol	4-Hydroxybenzene methanol; p-Hydroxybenzyl alcohol; p-(Hydroxymethyl)phenol; (4-Hydroxyphenyl)methanol
H172	4-Hydroxybutyric acid lactone	γ -Butyrolactone; 4-butanolide; Dihydro-2(3H)-furanone; Butyro-1,4-lactone; 4-Hydroxybutanoic acid lactone; 1,4-Epoxy butan-1-one; 2-Oxo oxolen; 3 (or 4-)-Hydroxybutyric acid, lactone; 1,2-Butanolide
H173	Hydroxycitronellal *	Citronellalhydrate; Oxydihydrocitronellal; Lily aldehyde; 3,7-Dimethyl-7-hydroxy octanal; 7-Hydroxy-3,7-dimethyl octan-1-al; Laurine, Citronellaldehyde; 3,7-Dimethyl-1,7-octanediol; 7-Hydroxy-3,7-dimethyloctan-1-al
H174	Hydroxycitronellal diethyl acetal	1,1-Diethoxy-3,7-dimethyl-7-octanol; 8,8-Diethoxy-2,6-dimethyl-2-octanol; 1,1- Diethoxy-3,7-dimethyloctan-7-ol; 7-Hydroxy-1,1-diethoxy-3,7-dimethyl octane
H175	Hydroxycitronellal dimethyl acetal*	8,8-Dimethoxy-2,6-dimethyl-2-octanol; 1,1-Dimethoxy-3,7-dimethyl-7-octanol; 8,8-Dimethoxy-2,6-dimethyl-2-octanol; 1,1- Dimethoxy-3,7-dimethyloctan-7-ol
H176	Hydroxycitronellol	3,7-Dimethyl-1,7-octanediol; Dyoxydihydrocitronello; citronellohydrate; 3,7-Dimethyloctane-1,7-diol; 3,7-Dimethyl-1,7-octanediol, 2,6-dimethyl-2,8-octanediol; 3,7- Dimethyloctane-1,7-diol; Hydroxycitronello; 7-Hydroxy-3,7-dimethyloctan-1-ol; Hydroxydihydrocitronello; hydroxyciol
H177	6-Hydroxydihydrotheaspirane	6-Hydroxy-2,6,10,10-tetramethyl-1-oxasprio(4,5)decane; 1-Oxasprio[4,5]decan-6-ol, 2,6,10,10-tetramethyl-[2S-2 α ,5 α (R-*)]]-
H178	3-(Hydroxymethyl)-2-heptanone	3-Octanon-1-ol; methylol methyl amyl ketone; Ketone alcohol; caproylethanol; 3-Oxo-1-octanol; hexanoylethanol; Octan-3-on-1-ol; Hexanoylethanoate; 1-hydroxyoctan-3-on
H179	3-Hydroxymethyl-2-octanone	3-(Hydroxymethyl)octan-2-one
H180	10-Hydroxymethylene-2-pinene	2-(6,6-Dimethylbicyclo[3.1.1]hept-2-en-2-yl)ethan-1-ol; 6,6-Dimethyl-bicyclo- [3.1.1]hept-2-ene-2-ethanol, Homomyrtenol; 2-Hydroxyethyl-6,6- dimethyl- bicyclo- [3,1,1]-hept-2-ene; 2-Norpinene-2-ethanol, 6,6-Dimethyl-; Nopol; 6,6-Dimethyl-2- norpinene-2-ethanol

Order	General Name	Synonyms
H181	Hydroxynonanoic acid delta-lactone	5-Nonanolide; 6-Butyltetrahydro-2pyrone, delta-Nonalactone; Nona-1,5-lactone; 5-n-Butyl-5-hydroxypentanoic acid lactone; 5-Hydroxynonanoic acid lactone; 5-n-Butyl- δ -valerolactone; Nonano-1,5-lactone; δ -Nonalactone; α ,n-Butyl- δ -hydroxypelargonic acid, lactone; 6-Butyltetrahydro-2H-pyrann-2-one; 1,5-Nonanolactone; Nonanolide-1,5; n-Butyl-delta-valerolactone
H182	4-(p-Hydroxyphenyl)-2-butanone	1-p-Hydroxyphenyl-3-butanone; oxyphenylon; p-Hydrobenzylacetone; p-Hydroxybenzyl acetone; 4-(4-Hydroxyphenyl)butan-2-one; Raspberry ketone; Rastone; Oxanone
H183	(+/-)-2-Hydroxypiperitone	Piperitone, 2-hydroxy-; Diosphenol; Buccocamphor; 2-Hydroxy-6-isopropyl-3-methyl- 2-cyclohexen-1-one
H184	5-Hydroxyundecanoic acid delta-lactone	5-Undecanolide; 6-Hexyltetrahydro-2-pyrone; Undeca-1,5-lactone; delta-Undecalactone; 5-n-Hexyl-5-hydroxypentanoic acid lactone; δ -n-Hexyl- δ -valerolactone; Undecano- 1,5-lactone; 5-Hydroxyundecanoic acid lactone; Undecanolide-1,5; α -nhexyl- delta- valerolactone; 5-n-Hexyl-5-hydroxypentanoic acid
H185	3-(4-hydroxy-phenyl)-1-(2,4,6-trihydroxy-phenyl)-propan-1-one	Phloretin; 2',4',6'-trihydroxy-3-(p-hydroxyphenyl)propiophenone; beta.-(p-Hydroxyphenyl)-2,4,6-trihydroxypropiophenone; beta-(p-Hydroxyphenyl)phloropropiophenone; 2',4',6'-Trihydroxy-3-(4-Hydroxyphenyl)propiophenone; 2',4',6'-Trihydroxy-3-(p-hydroxyphenyl)propiophenone; Dihydrongeninin; Naringenin dihydrochalcone; Phloretol
H186	5-Hydroxymethylfurfuraldehyde	2-Furaldehyde, 5-(hydroxymethyl)-; 5-Hydroxymethylfurfural; Hydroxymethylfurfurole; 5-(Hydroxymethyl)Furfurole; 5-(Hydroxymethyl)-2-formylfuran;5-(Hydroxymethyl)-2-furaldehyde; 5-(Hydroxymethyl)-2-furancarbal; 5-(Hydroxymethyl)-2-furfural; 5-(Hydroxymethyl)-2-furfuraldehyde; 5-(Hydroxymethyl)furan-2-aldehyde; 5-(Hydroxymethyl)furfural;5-Oxymethylfurfurole; 5-Hydroxymethylfurfuraldehyde; 5-Hydroxymethyl-2-furancarbaldehyde; Hydroxymethylfurfuraldehyde; 5-(Hydroxymethyl)-2-furancarboxaldehyde; 2-Hydroxymethyl-5-furfural; 5-(hydroxymethyl)-2-furfural (HMF);2-Furancarboxaldehyde, 5-(hydroxymethyl)-

Order	General Name	Synonyms
H187	4-Hydroxyacetophenone	Ethanone, 1-(4-hydroxyphenyl)-; p-Hydroxyacetophenone; p-Hydroxyphenyl methyl ketone; p-Oxyacetophenone; Methyl p-hydroxyphenyl ketone; Phenol, p-acetyl-; Piceol; 4'-Hydroxyacetophenone; Acetophenone, p-hydroxy-; Hydroxyacetophenone, para; p-Acetylphenol; 4-Acetylphenol
H188	Hexadecano-1,16-lactone	Cyclohexadecanolide; Dihydroambrettolide; Hexadecanoic acid, 16-hydroxy-, o-lactone; Hexadecanolide; Juniperic acid lactone; 1,16-Hexadecanolide; 16-Hexadecanolactone; 16-Hexadecanolide; Hexadecanolid; 1,16-Hexadecanolactone; 16-Hydroxyhexadecanoic acid lactone; Oxacycloheptadecan-2-one
H189	1-Hydroxypropan-2-one	Acetol; Hydroxyacetone; Acetone alcohol; Acetylcarbinol; Hydroxypropanone; Methanol, acetyl-; 1-Hydroxy-2-propanone; hydroxyacetone (acetol); hydroxypropan-2-one; 1-Hydroxyacetone; -Hydroxy-2-propanone 2-Propanone, 1-hydroxy-
H190	4-Hydroxy-4-methylpentan-2-one	2-Pentanone, 4-hydroxy-4-methyl-; Acetyltrimethylcarbinol; Diacetone alcohol; Diketone alcohol; Tyranton; 4-Hydroxy-4-methylpentanone; 4-Hydroxy-4-methyl-2-pentanone; 2-Methyl-2-pentanol-4-one; 4-Methyl-2-pentanone-4-ol; 4-Hydroxy-2-keto-4-methylpentane; 4-Hydroxy-4-methyl-pentan-2-on; Diacetone; 4-Hydroxy-4-methylpentanone-2; 2-Hydroxy-2-methyl-4-pentanone; 2-Methyl-3-pentanol-4-one; 4-Methyl-4-hydroxy-2-pentanone; Hydroxy-4-methyl-2-pentanone; Pyraton
H191	4-Hydroxy-3-methoxycinnamaldehyde	

Order	General Name	Synonyms
H192	2-Hydroxy-4-methylvaleric acid	
H193	2-(4-Hydroxyphenyl)ethan-1-ol	p-Hydroxyphenethyl alcohol; 4-Hydroxyphenethyl alcohol; β -(p-Hydroxyphenyl)ethanol; β -(4-Hydroxyphenyl)ethanol; 2-(p-Hydroxyphenyl)ethanol; 2-(4-Hydroxyphenyl)ethanol; 4-Hydroxyphenylethanol; Phenethyl alcohol, p-hydroxy-; p-Thyrosol; Tyrosol; p-Tyrosol; 4-Hydroxyphenylethyl alcohol; p-Hydroxyphenylethyl alcohol; Ethanol, 2-(4-hydroxyphenyl); p-Hydroxy-benzeneethanol; tyrosol [2-(4-hydroxyphenyl)ethanol];Benzeneethanol, 4-hydroxy-;4-(2-Hydroxyethyl)phenol
H194	4-Hydroxy-3,5-dimethoxybenzoic acid	Benzoic acid, 4-hydroxy-3,5-dimethoxy-; 3,5-Dimethoxy-4-hydroxybenzoic acid; Cedar acid;Syringic acid
H195	4-Hydroxy-3,5-dimethoxycinnamic acid	3,5-Dimethoxy-4-hydroxycinnamic acid; Sinapinic acid; Sinapic acid; trans-3,5-Dimethoxy-4-hydroxycinnamic acid; 2-Propenoic acid, 3-(4-hydroxy-3,5-dimethoxyphenyl)-; (2E)-3-(4-Hydroxy-3,5-dimethoxyphenyl)-2-propenoic acid;Cinnamic acid, 4-hydroxy-3,5-dimethoxy-
H196	Heptyl heptanoate	Heptyl heptoate;Heptanoic acid, heptyl ester
H197	Hexadec-1-yl acetate	Acetic acid, hexadecyl ester; Cetyl acetate; Hexadecyl acetate; Palmityl acetate; n-Hexadecyl ethanoate; 1-Acetoxyhexadecane; Acrylated lanolin alcohol; hexadecanyl acetate
H198	Hexadecanal	Palmitaldehyde; 1-hexadecanal;n-Hexadecanal

Order	General Name	Synonyms
H199	Hexadecano-1,4-lactone	2(3H)-Furanone, 5-dodecyldihydro-; Hexadecanoic acid, 4-hydroxy-, γ -lactone; γ -Palmitolactone; 5-Dodecyldihydro-2(3H)-furanone; γ -hexadecalactone
H200	5-Hexenol	1-Hexen-6-ol; Hex-5-en-1-ol;5-Hexen-1-ol
H201	cis-4-hexen-1-ol	(4Z)-4-Hexen-1-ol; (Z)-4-Hexen-1-ol;4-Hexen-1-ol, (z)-
H202	trans-3-hexenol	trans-3-Hexen-1-ol; trans-3-Hexenol; E-3-Hexenol; (E)-Hex-3-en-1-ol; (3E)-3-Hexen-1-ol; 3(E)-hexen-1-ol; (3E)-Hexenol; (E)-3-Hexen-1-ol; (E)Hex-3-enol; (Z)-3-hexen-1-ol;3-Hexen-1-ol, (E)-
H203	Hexyl valerate	Pentanoic acid, hexyl ester; Hexyl pentanoate; Hexyl valerianate; Valeric acid, hexyl ester; 1-Hexyl n-valerate;Hexyl n-valerate
H204	Hexyl heptanoate	Heptanoic acid, hexyl ester
H205	2-Hexylpyridine	Pyridine, 2-hexyl-; Pyridine, 2-(n-hexyl)-
H206	4-Hydroxy-3-methoxycinnamic acid	2-Propenoic acid, 3-(4-hydroxy-3-methoxyphenyl)-; Ferulic acid; 3-(4-Hydroxy-3-methoxyphenyl)-2-propenoic acid; 3-(4-Hydroxy-3-methoxyphenyl)acrylic acid; 3-Methoxy-4-hydroxycinnamic acid; (2E)-3-(4-Hydroxy-3-methoxyphenyl)-2-propenoic acid;Cinnamic acid, 4-hydroxy-3-methoxy-
H207	Heptadecan-1-ol	n-Heptadecanol; Heptadecyl alcohol; 1-Hydroxyheptadecane; Prim-n-heptadecyl alcohol; Heptadecanol;1-Heptadecanol
H208	1-Hexene-3-one	Propyl vinyl ketone; Vinyl propyl ketone
H209	Heptane-1-thiol	n-Heptylmercaptan; Heptyl mercaptan; Heptyl thiol; Normal-heptyl mercaptan

Order	General Name	Synonyms
H210	4-Hydroxy-3,5-dimethoxyacetophenone	Acetophenone, 4'-hydroxy-3',5'-dimethoxy-; Acetosyringone; 1-(4-Hydroxy-3,5-dimethoxyphenyl)ethanone; 3',5'-Dimethoxy-4'-hydroxyacetophenone; Acetosyringon; 3,5-Dimethoxy-4-hydroxyacetophenone; Acetophenone, 3,5-dimethoxy-4-hydroxy-; 1-(4-Hydroxy-3,5-dimethoxyphenyl)-ethanone (acetosyringone); 4-acetylsyringol; Phenol, 4-acetyl-2,6-dimethoxy; Ethanone, 1-(4-hydroxy-3,5-dimethoxyphenyl)-
H211	Heptano-1,5-lactone	Heptanoic acid, 5-hydroxy-, δ -lactone; 6-Ethyltetrahydro-2H-pyran-2-one; 2H-pyran-2-one, 6-ethyltetrahydro-; δ -Heptalactone; 5-Hydroxyheptanoic acid lactone
H212	Hexanal diethyl acetal	1,1-Diethoxyhexane; n-Hexanal diethyl acetal; Hexane, 1,1-diethoxy-
H213	4-Hydroxymethyl-2-methyl-1,3-dioxolane	
H214	trans-3-Hexenyl acetate	(3E)-3-Hexenyl acetate; (3E)-Hexenyl acetate; (E)-3-hexen-1-ol acetate; (E)-3-Hexen-1-yl acetate; (E)-3-hexenol acetate; (E)-3-Hexenyl acetate; (E)-Hex-3-enol acetate; 3-Hexen-1-ol, acetate, (e)-
H215	4-Hydroxy-3,5-dimethoxycinnamaldehyde	
H216	Heptanal propylene glycol acetal	
H217	Hexyl isothiocyanate	Hexane, 1-isothiocyanato-; Isothiocyanic acid, hexyl ester; n-Hexyl isothiocyanate; 1-Isothiocyanatohexane
H218	4-Hydroxybenzyl methyl ether	
H219	2-Heptyl acetate	1-Methylhexyl acetate; 2-Heptanol, acetate

Order	General Name	Synonyms
H220	Hexyl nonanoate	Nonanoic acid, hexyl ester
H221	sec-Heptyl hexanoate	Hexanoic acid, 1-methylhexyl ester;1-Methylhexyl hexanoate;2-heptyl hexanoate
H222	3,7,10-Humulatriene	1,4,8-Cycloundecatriene, 2,6,6,9-tetramethyl-, (E,E,E)-; Humulene; Cycloundeca-1,4,8-triene,2,6,6,9-tetramethyl-; 2,6,6,9-Tetramethyl-1,4,8-cycloundecatriene; α -Caryophyllene
H223	Heptyl hexanoate	Hexanoic acid, heptyl ester;N-heptyl hexanoate
H224	Hexyl decanoate	Decanoic acid, hexyl ester
H225	Hept-3-en-1-ol	(3E)-3-Hepten-1-ol;3-Hepten-1-ol
H226	Hexyl lactate	propanoic acid, 2-hydroxy-, hexyl ester
H227	Hexyl 9-octadecenoate	
H228	Hexanal dihexyl acetal	
H229	Hexyl dodecanoate	
H230	Hex-4-enyl acetate	4-Hexen-1-ol, acetate, (z)-; (Z)-4-Hexen-1-yl, acetate;cis-4-Hexenyl acetate
H231	Hexyl tetradecanoate	
H232	5-hexenyl isothiocyanate	hexenyl isothiocyanate
H233	Heptyl 2-methylbutyrate	heptyl 2-methylbutanoate;Butanoic acid, 2-methyl-, heptyl ester
H234	Heptyl isovalerate	
H235	trans-3-Hexenyl hexanoate	(E)-3-Hexen-1-ol, hexanoate;(E)-3-hexenyl hexanoate
H236	cis-3-Hexenyl heptanoate(3-Hexenyl heptanoate)	Heptanoic acid, 3-hexenyl ester, (z)-; (3Z)-3-Hexenyl heptanoate;(Z)-3-hexenyl heptanoate

Order	General Name	Synonyms
H237	cis-3-Hexenyl octanoate(Hex-3-enyl octanoate)	Octanoic acid, 3-hexenyl ester, (z)-; cis-3-Hexanyl n-octanoate; (3Z)-3-Hexenyl octanoate; (Z)-3-hexenyl octanoate
H238	cis-3-Hexenyl salicylate(Hex-3-enyl salicylate)	Benzoic acid, 2-hydroxy-, 3-hexenyl ester, (Z)-; Salicylic acid, 3-hexen-1-yl ester; β,γ -cis-Hexenyl salicylate; Salicylic acid, 3-hexenyl ester, (Z)-; (3Z)-3-Hexenyl salicylate; (Z)-3-Hexenyl salicylate
H239	3-Hexenyl methyl carbonate	
H240	Hex-2-enyl phenylacetate	
H241	cis-3-hexenyl decanoate(Hex-3-enyl decanoate)	Decanoic acid, 3-hexenyl ester, (z)-;cis-3-Hexenyl n-decanoate; (3Z)-3-Hexenyl decanoate
H242	sec-Hept-4(cis)-enyl acetate	
H243	trans-2-Hexenyl 2-methylbutyrate	hexenyl methyl butyrate
H244	trans-2-Hexenal propylene glycol acetal	(+/-)(E) & (Z)-2-Hexenal propylene glycol acetal; 1,3-Dioxolane, 4-methyl-2-(1E)-1-pentenyl- (9CI); 1,3-Dioxolane, 4-methyl-2-(1-pentenyl)-, (E)-
H245	Hexanal butane-2,3-diol acetal	
H246	Hexanal octane-1,3-diol acetal	hexanal 1,3-octanediol acetal;hexanal octanediol acetal
H247	Hexenal glyceryl acetal	
H248	Hex-3-enyl hexadecanoate	
H249	Hex-3-enyl 2-ethylbutyrate	
H250	sec-Heptyl isovalerate	
H251	Hexanal hexyl isoamyl acetal	

Order	General Name	Synonyms
H252	N-(2-Hydroxyethyl)-2,3-dimethyl-2,3-dimethyl-2-isopropylbutanamide	N-(2-Hydroxyethyl)-2,3-dimethyl-2-(1-methylethyl) butanamide; N-(2-Hydroxyethyl)-2-isopropyl-2,3-dimethylbutanamide
H253	delta-Hexadecalactone	Tetrahydro-6-undecyl-2H-pyran-2-one; 6-Undecyltetrahydropyran-2-one; delta-Hexadecanolide; delta-Palmitolactone; 5-Hexadecanolide; 5-Hydroxyhexadecanoic acid delta lactone; 6-Undecyltetrahydro-2H-pyran-2-one
H254	cis-3-Hexenoic acid	(Z)-Hex-3-enoic acid
H255	cis-3-Hexenyl acetoacetate	Butanoic acid, 3-oxo-, (3Z)-3-hexenyl ester; (Z)-Hex-3-en-1-yl 3-oxobutanoate
H256	2-Hexyl-2-decenal	
H257	2-Hexylidenehexanal	2-Butyl-2-octenal
H258	4-Hydroxy-6-methyl-2-heptanone	
H259	3-Hydroxy-3-methyl-2,4-nonanedione	Lactadione
I001	Indole	Benzopyrrole; 1-Benzazole; 1-Benzazole; 1-BenzoPyrrole; 2,3-Benzopyrrole
I002	α-Ionol	3-Buten-2-ol, 4-(2,6,6-trimethyl-2-cyclohexen-1-yl)-; 4(2,6,6-trimethyl-2-cyclohexenyl)-3-buten-2-ol; 4-(2,6,6-Trimethyl-2-cyclohexenyl)but-3-en-2-ol
I003	β-Ionol	4-(2,2,6-Trimethyl-1-cyclohexenyl)but-3-en-2-ol; 3-Buten-2-ol, 4-(2,6,6-trimethyl-1-cyclohexen-1-yl)-; 4-(2,6,6-trimethyl-1-yl)-3-buten-2-ol
I004	α-Ionone*	1-(2,6,6-Trimethyl-1,3-cyclohexadienyl)-2-buten-1-one; 4-(2,6,6 Trimethylcyclohexa- 1,3-dienyl)but-2-en-4-one; floriffone; α-risone; α-Cyclocitrylideneacetone; 4-(2,6,6- Trimethyl-2-cyclohexen-1-yl)-3-buten-2-one
I005	β-Ionone*	Ionone; β-Cyclocitrylideneacetone; 4-(2,6,6-Trimethyl-1-cyclohexen-1-yl)-3-buten-2-one; Irisone
I006	γ-Ionone	4-(2-Methylene-6,6-dimethylcyclohexyl)-3-buten-2-one; 4-(2,2-Dimethyl-6-methylenecyclohexyl)-3-buten-2-one

Order	General Name	Synonyms
I007	β -Ionone epoxide	3-Buten-2-one, 4-(2,2,6-trimethyl-7-oxabicyclo[4.1.0]hept-1-yl)-; 4-(2,6,6-Trimethyl- 7-oxabicyclo[4.1.0]heptane, 3-buten-2-one; β -Ionone 5,6-epoxide; β -Ionone epoxide; 4-(1,2-Oxido-2,6,6-trimethylcyclohexyl)-3-buten-2-one; 4-(2,6,6-Trimethyl-1,2- epoxycyclohexyl)-3-buten-2-one; 5,6- β -Ionone epoxide; 5,6-Epoxy- β -ionone
I008	β -Ionyl acetate	3-Buten-2-ol, 4-(2,6,6-trimethyl-1-cyclohexen-1-yl)-, acetate
I009	α -Irone	6-Methylionone; 6-Methyl- α -ionone; 4-(2,5,6,6-Tetramethyl-2- cyclohexenyl)-3- buten-2-one; cis-(2,6)-cis-(21,22)- α -Irone; 6-methyl-x-ionone; 4-(2,5,6,6-Tetramethyl- 2-cyclohexen-1-yl)-3-buten-2-one; 6-Methyl- α -ionone
I010	Isoambrettolide	Oxacycloheptadec-10-en-2-one; 9-Hexadecenoic acid, 16-hydroxy-, o-lactone; delta- 9-Isoambrettolic acid, lactone; Oxacycloheptadec-10-en-2-one
I011	Isoamyl 2-furanpropionate	a-Isoamyl furfurylacetate.
I012	Isoamyl 2-methylbutyrate	3-Methylbutyl 2-methylbutanoate; Isoamyl 2-methylbutanoate; Isopentyl 2- methylbutanoate
I013	Isoamyl acetate*	Amyl isoacetate; 3-Methylbutyl acetate; Amyl iso ethanoate; Isoamyl ethanoate; Isopentyl acetate; Common amyl acetate; β -Methylbutyl acetate; Isoamyl ethanoate
I014	Isoamyl acetoacetate	
I015	Isoamyl alcohol	Butyl iso carbinol; Amyl iso alcohol; Pentyl iso alcohol; Isopentanol; Isobutyl carbinol; isopentyl alcohol; 3-Methyl-1-butanol; Isopentyl alcohol
I016	Isoamyl benzoate	Pentyl iso benzoate; Amyl iso benzoate; Benzoic acid, isopentyl ester; 3-Methylbutyl benzoate; Amyl benzoate; Isopentyl benzoate; Isopentyl phenyl methanoate

Order	General Name	Synonyms
I017	Isoamyl butyrate*	Amyl iso butyrate; Pentyl iso butyrate; isopentyl butanoate; Isoamyl butanoate; Pentyl iso butanoate; Amyl iso butanoate; 3-methylbutyl butanoate; 3-Methylbutyl butyrate; Isopentyl butyrate; Isoamyl n-butyrate
I018	Isoamyl cinnamate	Pentyl iso cinnamate; Amyl iso cinnamate; Cinnamic acid, Isoamyl ester; Pentyl iso 3-phenylacrylate; Amyl iso β -phenylacrylate; Pentyl iso 3-phenylpropenoate; isopentyl β -phenylacrylate; Isoamyl β -phenylacrylate; Isoamyl 3-phenyl-propenoate; Isopentyl cinnamate
I019	Isoamyl formate*	Amyl iso formate; Pentyl iso formate; Pentyl iso methanoate; Isopentyl methanoate; Amyl iso methanoate; Isoamyl methanoate; 3-Methylbutyl formate; Isopentyl formate; Isoamyl formate
I020	Isoamyl formate	3-Methylbutyl 3-furylpropionate; Amyl(iso) 2-furanpropionate; Isoamyl 2-furanpropionate; Isoamyl 2-furylpropionate; Isopentyl 2-furanpropionate; Isoamyl furylpropionate; Isoamyl furfurylacetate; Isoamyl furfurylhydracrylate; α -Isoamyl furfurylacetate
I021	Isoamyl hexanoate	Pentyl iso hexanoate; Pentyl iso caproate; Isopentyl caproate; Amyl iso hexanoate; amy l iso caproate, 3-methylbutyl hexanoate; Isoamyl caproate; Isoamyl capronate; isoamyl hexylate; Isopentyl hexanoate; Isoamyl hexanoate; Isopentyl n-hexanoate
I022	Isoamyl isobutyrate	Isopentyl isobutyrate; 3-Methylbutyl 2-methylpropanoate; Isopentyl isobutyrate; Isoamyl 2-methylpropanoate; Iso-amyl 2-methylpropanoate; Iso-amyl isobutyrate; isopentyl 2-methylpropanoate
I023	Isoamyl isovalerate*	Amyl iso isovalerate; Pentyl iso isovalerate; Isopentyl isopentanoate; Isoamyl 3-methylbutanoate; Isoamyl isopentanoate; 3-Methylbutyl 3-methylbutyrate; 3-methylbutyl 3-methylbutanoate; Isopentyl 3-methylbutanoate; Pentyl iso 3-methylbutanoate; Pentyl iso isopentanoate; Amyl iso 3-methylbutanoate; Amyl iso isopentanoate; Isopentyl isovalerate; Isopentyl isopentanoate; Iso amyl β -methyl butyrate
I024	Isoamyl laurate	Amyl iso laurate; Amyl iso dodecanoate; Pentyl iso laurate; Pentyl iso dodecanoate; Isopentyl dodecanoate; Isopentyl dodecylate, 3-methylbutyl dodecanoate; Isoamyl dodecanoate; Isoamyl dodecylate; Isopentyl laurate; 3-Methylbutyl laurate; Isoamyl laurate

Order	General Name	Synonyms
I025	Isoamyl nonanoate	Pentyl iso nonanoate; Amyl iso nonanoate; Isopentyl nonylate; 3-Methylbutyl nonanoate; 3-Methylbutyl pelargonate; Isopentyl pelargonate; Amyl iso pelargonate; Amyl iso nonylate; Isoamyl nonylate; Isoamyl pelargonate; Isopentyl nonanoate
I026	Isoamyl octanoate	Pentyl iso octanoate; Amyl iso octanoate; amyl iso caprylate; Pentyl iso octylate; Isopentyl octylate; Amyl iso octylate; 3-Methylbutyl octanoate; Isoamyl caprylate; isoamyl octylate; Isopentyl octanoate; Isopentyl octanoate
I027	Isoamyl phenylacetate	Amyl iso phenylacetate; Pentyl iso phenylacetate; Phenylacetic acid, Isopentyl ester; Amyl iso α -toluate; 3-Methylbutyl phenylacetate; Isoamyl α -toluate; Isopentyl phenylacetate; Pentyl phenylacetate and 3-methylbutyl phenylacetate
I028	Isoamyl propionate*	Amyl iso propionate; Pentyl iso propionate; Isopentyl propanoate; Isoamyl propanoate; 3-methylbutyl propanoate; 3-Methylbutyl propionate; Pentyl iso propanoate; Amyl iso propanoate; Isopentyl propionate; Isoamyl propionate
I029	Isoamyl pyruvate	Amyl iso pyruvate' pentyl iso pyruvate; Isoamyl α -ketopropionate; Isoamyl 2-oxopropanoate; Isopentyl pyruvate; 3-Methylbutyl 2-oxopropanoate; Isoamyl pyrroacetate; Pentyl pyruvate
I030	Isoamyl salicylate	Amyl iso salicylate; Amyl iso o-hydroxybenzoate; Pentyl iso salicylate; 3-Methylbutyl o-hydroxybenzoate; 3-Methylbutyl salicylate; Pentyl iso o-hydroxybenzoate; Isopentyl o-hydroxybenzoate; Salicylic acid, isopentyl ester; Isoamyl 2-hydroxybenzoate; Isoamyl o-hydroxybenzoate; isopentyl salicylate; Isopentyl 2-hydroxybenzoate
I031	Isoborneol	Borneo(iso); Exo-2-camphanol; exo-2-bornanol; Isobornyl alcohol; Isocamphol; (iso)-Camphol; (exo)-2-Camphanol; (exo)-2-Bornanol; Bornan-2-ol; exo-1,7,7- Trimethylbicyclo[2.2.1]heptan-2-ol

Order	General Name	Synonyms
I032	Isobornyl 2-methylbutyrate	Butanoic acid, 2-methyl-, 1,7,7-trimethylbicyclo-[2.2.1]hept-2-yl ester
I033	Isobornyl acetate	Bornyl iso acetate; exo-2-bornyl acetate; Bornyl iso ethanoate; Isobornyl ethanoate; exo-2-camphanyl acetate; 2-Camphanyl acetate
I034	Isobornyl formate	Bornyl iso formate; exo-2-bornyl formate; Isobornyl methanoate; exo-2-camphanyl formate
I035	Isobornyl isobutyrate	Propanoic acid, 2-methyl-, (1R,2R,4R)-1,7,7-trimethylbicyclo[2.2.1]hept-2-yl ; Isobornyl 2-methylpropionate
I036	Isobornyl isovalerate	Isobornyl isovalerianate; Bornyl iso isovalerianate; Bornyl iso isovalerate; Isobornyl 3-methylbutanoate; Isobornyl isopentanoate; Bornyl iso isopentanoate; Bornyl iso 3-methylbutanoate; Isobornyl 3-methylbutyrate
I037	Isobornyl propionate	Bornyl iso propionate; exo-2-bornyl propionate; Isobornyl propionate; exo-2-camphanyl propionate
I038	Isobutyl 2-butenate	Isobutyl crotonate
I039	(+/-)-Isobutyl 3-methylthiobutyrate	2-Methylpropyl 3-(methylthio)butyrate; 2-Methylpropyl 3-(methylthio)butanoate; Butanoic acid, 3-(methylthio)-, 2-methylpropyl ester; Isobutyl 3-(methylthio)butyrate
I040	Isobutyl acetate	Butyl iso acetate; Butyl iso ethanoate; 2-methyl-1-propyl acetate; isobutyl ethanoate
I041	Isobutyl acetoacetate	Butyl iso acetoacetate; butyl iso 3-ketobutyrate; isobutyl 3-ketobutyrate; Butyl iso 3-ketobutanoate; isobutyl 3-

Order	General Name	Synonyms
		ketobutanoate; 2-methyl-1-propyl acetoacetate; Butyl iso 3-Oxobutanoate; Isobutyl- β -ketobutyrate; Isobutyl-3-oxobutanoate; 2-Methylpropyl 3-oxobutyrate
I042	Isobutyl alcohol	Butyl iso alcohol; butanol(iso); Propyl iso carbinol; 2-Methyl-1-propanol; Isopropyl carbinol; Isobutanol; 2-Methylpropanol; 2- Methylpropan-1-ol; Isobutanol; Isopropyl carbinol
I043	Isobutyl angelate	Butyl iso angelate; Buty iso cis-2-methyl-2-butenate; Isobutyl 2-methylbut-2(cis)- enoate; Isobutyl cis- α,β -dimethylacrylate; Isobutyl cis-2-methyl-2-butenate; isobutyl cis- α -methylcrotonate
I044	Isobutyl anthranilate	Butyl iso anthranilate; Butyl iso o-aminobenzoate; Isobutyl 2-aminobenzoate; Isobutyl o-aminobenzoate
I045	Isobutyl benzoate	butyl iso benzoate; 2-methylpropyl benzoate; Isobutyl benzenecarboxylate, Eglantine; Isobutyl phenyl methanoate
I046	Isobutyl butyrate	Butyl iso butyrate; 2-methyl-1-propyl butyrate; butyl iso butanoate; isobutyl butanoate; 2-Methyl propanyl butyrate; 2-methylpropyl butanoate
I047	Isobutyl cinnamate	Isobutyl-3-phenylpropenoate; isobutyl- β -phenylacrylate; Labdanol; 2-methylpropyl cinnamate; 2-Methylpropyl β -phenylacrylate; 2-Methylpropyl 3-phenylpropenoate
I048	Isobutyl formate	Butyl iso formate; 2-Methyl-1-propyl formate; Isobutyl methanoate; Butyl iso methanoate; Tetryl formate
I049	Isobutyl furyl propionate	Isobutyl 3-(2-furyl)propionate; Isobutyl 2-furanpropionate; Isobutyl furfurylacetate; Isobutyl-2-furanpropionate
I050	Isobutyl heptanoate	Butyl iso heptanoate; Butyl iso heptoate; 2-Methyl-1-propyl heptanoate; Isobutyl heptoate; Isobutyl heptylate; Isobutyl heptoate

Order	General Name	Synonyms
I051	Isobutyl hexanoate	Butyl iso hexanoate; Butyl iso caproate; 2-Methyl-1-propyl caproate, 2-methylpropyl hexanoate; Isobutyl caproate; Isobutyl capronate; isobutyl hexylate
I052	Isobutyl isobutyrate	Butyl iso isobutyrate; Butyl iso 2-methylpropanoate; 2-Methyl-1-propyl 2-methylpropanoate; Isobutyl 2-methylpropanoate; Isobutyl 2-methylpropionate
I053	Isobutyl N-methylantranilate	Benzoic acid, 2-(methylamino)-, 2-methylpropyl ester
I054	Isobutyl phenylacetate*	Butyl iso phenylacetate; 2-Methylpropyl phenylacetate; Isobutyl α -toluate
I055	Isobutyl propionate	Butyl iso propionate; Isobutyl propanoate; Butyl iso propanoate; 2-Methyl-1-propyl propanoate
I056	Isobutyl salicylate	Butyl iso salicylate; 2-Methyl-1-propyl salicylate; Butyl iso o-hydroxybenzoate; 2-Methylpropyl o-hydroxybenzoate; Isobutyl o-hydroxybenzoate; Isobutyl 2-hydroxybenzoate; 2-Methylpropyl 2-hydroxybenzoate; Butyl salicylate
I057	2-Isobutyl-3-methoxypyrazine	2-Butyl-iso-3-methoxypyrazine; 2-Methoxy-3-(2-methylpropyl)pyrazine; 2-Methoxy-3- isobutylpyrazine; 2-Butyl-3-methoxypyrazine
I058	2-Isobutyl-3-methylpyrazine	2-Butyl-iso-3-methylpyrazine; 2-Methyl-3-isobutyl pyrazine; 2-methyl-3-(2- methylpropyl)-pyrazine; 2-(2-Methylpropyl)-3-methylpyrazine; 2-Isobutyl-3-methyl- 1,4-diazine; 2-Butyl-3-methylpyrazine
I059	2-Isobutyl-4,6-dimethyldihydro-1,3,5-dithiazine and 4-isobutyl-2,6-dimethyldihydro-1,3,5-dithiazine (mixture)	2(4)-Isobutyl-4(2),6-dimethyldihydro-4H-1,3,5-dithiazine; Dimethyl isobutyl dihydro- 1,3,5-dithiazine; Dihydro-2-isobutyl-4,6-dimethyl-4h-1,3,5-dithiazine and dihydro-6- isobutyl-2,4-dimethyl-4h-1,3,5-dithiazine
I060	Isobutylamine	1-Amino-2-methylpropane; 2-Methyl-1-aminopropane; 2-Methyl-1-propanamine; 2-Methylpropanamine; 2-Methylpropylamine; 3-Methyl-2-propylamine; iso-Butylamine; Monoisobutylamine; Valamine

Order	General Name	Synonyms
I061	N-Isobutyldeca-trans-2-trans-4-dienamide	N-Isobutyl (E2),(E4)-decadienamide; 2,4-Decadienamide, N-(2-methylpropyl)-, (2E, 4E)-; 2,4-Decadienamide, N-(2-methylpropyl)-, (E,E)-; 2,4-Decadienamide, N- isobutyl-, (E,E)-; (E,E)-N-(2-Methylpropyl)-2,4-decadienamide; N-(2-methyl- propyl)deca-trans-2-trans-4-dienamide; N-Isobutyl-2-trans-4-trans-decadienamide; N-Isobutyl deca-trans-2-trans-4-dienamide; Pellitorin; Pellitorine; trans-Pellitorine
I062	α -Isobutylphenethyl alcohol	Benzylisobutyl carbinol; α -butyl iso phenethyl alcohol; 2-Methylpropyl benzyl carbno; Benzyl isoamyl alcohol; isobutyl benzylcarbinol; 4-Methyl-1-yl-1- phenyl-2- pentanol; 4-Methyl-1-phenyl-2-pentanol, 2-Methyl propyl benzyl carbinol, Benzylisoamyl acetone; 4- Methyl-1-phenylpentan-2-ol
I063	2-Isobutylthiazole	2-Butyl iso thiazole; Thiazole, 2-isobutyl; 2-Butylthiazole
I064	Isobutyraldehyde	Butyraldehyde(iso); butyl iso aldehyde; Butyric iso aldehyde; Isobutyl aldehyde; isobutyric aldehyde; 2-Methyl propanal; Isobutanal
I065	Isobutyric acid	Butyric iso acid; 2-Methylpropionic acid; Isopropylformic acid; 2-Methylpropanoic acid; Isobutyric acid
I066	Isoeugenol*	4-Hydroxy-3-methoxy-1-propen-1-yl benzene; 3-Methoxy-4-hydroxy-1-propen-1-yl benzene; 1-Hydroxy-2-methoxy-4-propenylbenzene; 2-Methoxy-4-propenylphenol; 4-propenyl guaiacol; 1-Hydroxy-2-methoxy-4-propen-1-ylbenzene; 2-Methoxy-4-(1-propenyl)phenol
I067	Isoeugenyl acetate	Isoeugenol acetate; 4-Acetoxy-3-methoxy-1-(1-propen-1-yl) benzene; 2-Methoxy-4- (prop-1-enyl)phenyl acetate; Acetyl isoeugenol; 2-Methoxy-4-propenylphenyl acetate; Acetisoeugenol

Order	General Name	Synonyms
I068	Isoeugenyl benzyl ether	4-Propenyl-1(benzyloxy)-2-methoxybenzene; Benzyl 2-methoxy-4-propenylphenyl ether; 1-Benzyloxy-2-methoxy-4-propenylbenzene; 2-Methoxy-4-propenylphenyl benzyl ether; Benzyl isoeugenyl ether; Benzyl isoeugenol; 2-Methoxy-4-propenylphenyl ether
I069	Isoeugenyl ethyl ether	1-Ethoxy-2-methoxy-4-(prop-1-enyl)benzene; 1-Ethoxy-2-methoxy-4-propenylbenzene; 2-Ethoxy-5-propenylanisole; Ethyl isoeugenol; Ethyl isoeugenyl ether; 1-Ethoxy-2-methoxy-4-benzene
I070	Isoeugenyl formate	4-(1-Propen-1-yl)-2-methoxyphenyl formate; 2-Methoxy-4-(1-propen-1-yl) phenyl formate; 2-Methoxy-4-propenyl phenyl formate; propenyl-2-methoxyphenyl formate; 4-Methoxy-4-phenyl formate; 2-Methoxy-4-propenylphenyl formate
I071	Isoeugenyl methyl ether	Isoeugenol methyl ether; 3,4-Dimethoxy-1-(1-propen-1-yl) benzene; 1,2-Dimethoxy-4-propenylbenzene; Methyl isoeugenol; 4-Propenyl veratrole; 1,2-Dimethoxy-4-(prop-1-enyl)benzene; 1,2-Dimethoxy-4-propenyl
I072	Isoeugenyl phenylacetate	2-Methoxy-4-(1-propen-1-yl) phenyl phenylacetate; Isoeugenol α -toluate; 2-Methoxy-4-propenyl phenylacetate; 4-Propenylguaiacyl phenylacetate; 2-Methoxy-4-phenyl phenylacetate
I073	Isojasmone	2-hexylidene cyclopentanone and 2-hexyl-2-cyclopenten-1-one (mixture); 2-Hexyl-2-cyclopenten-1-one and 2-hexylidenecyclopentanone (mixture); 2-Methyl-3-(2-pentenyl)-2-cyclopenten-1-one; 2-Hexyl-cyclopenten-2-one-1
I074	DL-Isomenthone	cis-Menthone; cis-2-Methyl-5-isopropylcyclohexanone; d,l-Isomenthone; Cyclohexanone, 5-methyl-2-(1-methylethyl)-, (Z)-; Isomenthone; cis-para-Menthan-3-one; cis-1-Methyl-4-isopropyl-3-cyclohexanone; 1-Methyl-4-isopropyl-3-cyclohexanone; d,l-cis-para-Menthan-3-one

Order	General Name	Synonyms
1075	α -Isomethylionyl acetate	3-Methyl-4-(2,6,6-trimethyl-2-cyclohexen-1-yl)-3-buten-2-yl acetate
1076	α -Isomethyl ionone	γ -Methylionone; Raldeine- γ ; iraldeine- γ ; α -Cyclocitrylidene butanone; Methyl- γ - ionone(so called); 4-(2,6,6-Trimethyl-2-cyclohexen-1-yl)-3-methyl-3-buten-2-one; Isomethylionone
1077	β -Isomethylionone	3-Buten-2-one, 3-methyl-4-(2,6,6-trimethyl-1-cyclohexen-1-yl)-
1078	Isoorioenyl pyrazine (Isopropenyl)	2-(α -Methylvinyl) pyrazine; 2-Isopropenyl-1,4-diazine; 2-(1-methylvinyl)pyrazine; 2-Isopropenylpyrazine; Isopropenylpyrazine
1079	Isopentyl 4-(2-furan)butyrate	3-Methylbutyl 2-furylbutyrate; Amyl 2-furanbutyrate; Isoamyl 2-furanbutyrate; Isopentyl 2-furanbutyrate; Isopentyl furyl-2-butylate; Isoamyl furfurylpropionate; 3-Methylbutyl 2-furanbutyrate; α -Isoamyl furfurylpropionate
1080	Isopentyl acetoacetate	Amyl iso acetoacetate; Isopenetyl acetoacetate; 3-Methylbutyl acetoacetate; 3-methylbutyl 3-oxobutanoate; Isopentyl β -ketobutyrate; isopentyl β -ketobutyrate; Pentyl iso 3-oxobutanoate; Isopentyl 3-oxobutanoate; Amyl iso β -ketobutyrate; 3-Methylbutyl β -ketobutyrate; Amyl iso 3-oxobutanoate; Isoamyl β -ketobutyrate; Isoamyl 3-oxobutanoate, 3-Methylbutyl 3-oxobutyrate; Pentyl 3-Oxobutanoate
1081	Isopentyl amine	Pentyl iso amine; 1-Aminoisopentane; Butyl iso carbylamine; Isoamylamine; 3-Methylbutylamine; isoamino pentane; Isobutyl carbylamine; 1-Butanamine, 3-methyl-
1082	Isopentylidene isopentylamine	N-(3-Methylbutylidene)-3-methyl-1-butylamine; N-Isoamylidene-isoamylamine; 1-Butanamine, 3-methyl-N-(3-methylbutylidene)-

Order	General Name	Synonyms
1083	Isophorone	2-Cyclohexen-1-one, 3,5,5-trimethyl-; isoacetophorone; 3,5,5-Trimethyl-2-cyclohexen- 1-one; 3,5,5-Trimethylcyclohex-2-en-1-one; 1,5,5-Trimethyl-3-oxocyclohexene; 1,3,3-Trimethylcyclohexane-5-one; Isophorone
1084	Isoprenyl acetate	3-Methyl-3-butenyl acetate
1085	Isopropenyl acetate	
1086	5-Isopropenyl-2-methyl-2-vinyl tetrahydrofuran	Anhydro linalool oxide; 2-Ethenyl-2-methyl-5-(1-methylethenyl) tetrahydrofuran; furan, 2-ethenyl-tetrahydro-2-methyl-5-(1-methylethenyl)-; 2-Methyl-2-vinyl- 5- isopropenyl tetrahydroforan; Anhydrolinalool oxide
1087	cis-5-Isopropenyl-cis-2-methylcyclopentan-1-carboxaldehyde	Cyclopentanecarboxaldehyde, 2-methyl-5-(1-methylethenyl)-, [R-(1 α ,2 α ,5 α 0)-; <i>cis</i> -2-methyl- <i>cis</i> -5-isopropenylcyclopentan-1-carboxaldehyde; Photocitral; 5-(1- Methylene-ethyl)-2-methylcyclopentanecarboxaldehyde; Photocitral; 5- Isopropenyl-2- methylcyclopentanecarboxaldehyde; Photocitral A
1088	Isopropyl 2-methylbutyrate	Butanoic acid, 2-methyl-, 1-methylethyl ester; 1-Methylethyl-2-methylbutanoate
1089	Isopropyl acetate	Propyl iso acetate
1090	Isopropyl alcohol *	Propyl iso alcohol; Propanol(iso); Petrohol; sec-Propyl alcohol; Dimethylcarbinol; Isopropanol; 2-propanol; Isopropanol; Propan-2-ol; Isopropanol

Order	General Name	Synonyms
I091	Isopropyl benzoate	Propyl iso benzoate; 1-Methylethyl benzoate
I092	Isopropyl butyrate	Propyl iso butyrate; propyl iso butanoate; Isopropyl butanoate; Isopropyl n-butanote; Isopropyl
I093	Isopropyl cinnamate	Propyl iso cinnamate; 1-Methylethyl-3-phenylpropenoate; Isopropyl β -phenylacrylate; Isopropyl 3-phenylpropenoate
I094	Isopropyl formate	Isopropyl methanoate; Propyl iso formate; Propyl iso methanoate
I095	Isopropyl hexanoate	Propyl iso hexanoate; Propyl iso hexylate; Propyl iso capronate; Propyl iso caproate; Isopropyl caproate; Isopropyl capronate; isopropyl hexylate
I096	Isopropyl isobutyrate	Propyl iso isobutyrate; Isopropyl 2-methylpropanoate; Propyl-iso-2-methylpropanoate
I097	Isopropyl isovalerate	Propyl iso isovalerate; Isopropyl isovalerianate; Propyl iso isopentanoate; Isopropyl isopentanoate; Isopropyl 3-methylbutanoate; Propyl iso 3-methylbutanoate
I098	Isopropyl myristate	Tetradecanoic isopropyl ester; Isopropyl tetradecanoate; Tetradecanoic acid, 1-Methylethyl ester; Isopropyl myristate
I099	p-Isopropyl phenylacetaldehyde	p-Propyl iso phenylacetaldehyde; Cortexal; Cumylacetaldehyde; Cuminic acetaldehyde; p-Cymen-7-carboxaldehyde; homo-cuminic aldehyde; 4-Isopropyl phenyl acetaldehyde; 2-(p-Isopropylphenyl)acetaldehyde; Cumylaldehyde; p-Propylphenylacetaldehyde
I100	Isopropyl phenylacetate	Isopropyl α -toluate
I101	Isopropyl propionate	Propyl iso propionate; Isopropanoate
I102	Isopropyl sorbate	Propan-2-yl(2E, 4E)-hexa-2,4-dienoate; 2,4-Hexadienoic acid, 1-methylethyl ester; Isopropyl 2,4-hexadienoate

Order	General Name	Synonyms
I103	Isopropyl tiglate	Crotonate; Isopropyl-2-methyl-2-butenate; Propyl iso tiglate; Propyl iso α -methylcrotonate; Isopropyl 2-methylcrotonate; Isopropyl- α -methyl crotonate; isopropyl-3-methyl-2-butenate; Propyl tiglate
I104	4-Isopropyl-2-cyclohexenone	2-Cyclohexenone, 4-(1-methylethyl)-; 4-Isopropylcyclohex-2-enone; 4-Isopropylcyclohex-2-en-1-one, Crypton; Cryptone; dl-Kryptone
I105	2-Isopropyl-4,6-dimethyl and 4-isopropyl-2,6-dimethyldihydro-1,3,5-dithiazine (mixture)	2(4)-Isopropyl-4(2),6-dimethyldihydro-4H-1,3,5-dithiazine; 4,6-Dimethyl-2- (1-methylethyl)dihydro-1,3,5-dithiazine; Dimethyl isopropyl dihydro-1,3,5-dithiazine; Dihydro-2-isopropyl-4,6-dimethyl-4h-1,3,5-dithiazine and dihydro-4-isopropyl-2,6- dimethyl-4h-1,3,5-dithiazine
I106	2-Isopropyl-4-methylthiazole	Thiazole, 4-methyl-2-(1-methylethyl)-; 4-Methyl-2-isopropylthiazole
I107	2-Isopropyl-5-methyl-2-hexenal	<i>iso</i> -Dihydrovandulyl aldehyde
I108	p-Isopropylacetophenone	p-Propyl iso acetophenone; p-Isopropylacetylbenzene; 4-Isopropylacetophenone; Acetocumene; p-Acetyl cumol; 1,4-Acetyl-isopropyl benzol; 1-Isopropyl-4- acetylbenzene; p-Isopropyl acetylbenzol; Methyl p-isopropylphenyl ketone; 1-(4-Isopropylphenyl)ethanone; p-Acetylcumene; p-Propylacetophenone
I109	Isopropylamine	1-Methylethylamine; 2-Aminopropane; 2-Propylamine; Monoisopropylamine; sec-Propylamine
I110	p-Isopropylbenzyl alcohol	Cuminol; Cumin alcohol; p-Cymen-7-ol; Cumic alcohol; Cuminic alcohol; Cuminol; Cuminy alcohol; p-cymen-1-ol; 4-Isopropylbenzyl alcohol
I111	Isopropylmethoxypyrazine	2-Ethyl (or methyl)-(3,5 or 6)-isopropylpyrazine; 2-Isopropyl-(3,5 or 6)-methoxypyrazine; 2-propyl-iso-(3,6 or 6)-methoxypyrazine; 2-Isopropyl-3- methoxypyrazine; 2-Isopropyl-5-methoxypyrazine; 2-Isopropyl-6-methoxypyrazine; 2-methoxy-3 or 6-(1-methylethyl)pyrazine; Methoxy isopropyl pyrazines mixture; 2- Isopropyl-3-methoxypyrazine; 2-Methoxy-(3,5 or 6)-isopropylpyrazine

Order	General Name	Synonyms
I112	2-Isopropyl-N,2,3-trimethyl butyram	2-Isopropyl- N,2,3-trimethylbutanamide; N,2,3-Trimethyl-2-(1-methylethyl)butanamide; 2-Isopropyl-N,2,3-trimethylbutyramide; N,2,3-trimethyl-2-isopropylbutanamide
I113	2-Isopropylphenol	<i>o</i> -Cumenol; 1-Hydroxy-2-isopropylbenzene; <i>o</i> -Isopropylphenol; Phenol, 1-(1-methylethyl)-; Phenol, 2-(1-methylethyl)-; 1-Hydroxy-1-isopropylbenzene
I114	3-(<i>p</i> -Isopropylphenyl)propionaldehyde	<i>p</i> -Propyl iso hydrocinnamaldehyde; 3-(4-Isopropylphenyl)propionaldehyde; Cuminyal acetaldehyde; <i>p</i> -cymyl propanal; <i>p</i> -Isopropylhydrocinnamaldehyde; 3-(<i>p</i> -Isopropylphenyl)-propionic aldehyde; 3-(<i>p</i> -Cumenyl)propionaldehyde, <i>p</i> -Cuminyalpropanal; 3-(<i>p</i> -Cumenyl)propionaldehyde
I115	2-Isopropylpyrazine	Pyrazine, (1-methylethyl)- isopropyl-Pyrazine; Isopropylpyrazine; Isopropyl-1,4-diazine
I116	Isopulegol	Pulegol (iso); <i>p</i> -8(9)-Menthen-3-ol; <i>p</i> -Menth-8-en-3-ol; 1-Methyl-4-isopropenyl- cyclohexan-3-ol; <i>p</i> -Menth-8(9)-en-3-ol; <i>l</i> -Isopulegol
I117	Isopulegone	δ -8(9)- <i>p</i> -Menthen-3-one; 1-Isopropyl-4-methyl-2-cyclohexanone; 1-Propyl-iso-4- methyl-2-cyclohexanone; <i>p</i> -Menth-8-en-3-one; 1-Methyl-4-isopropenylcyclo- hexan-3-one; 1-Methyl-4-isopropenyl-3-cyclohexanone; trans- <i>p</i> -Menth-8-en-3- one
I118	Isopulegyl acetate	Pulegol-iso-acetate; 1-Methyl-4-isopropenylcyclohexan-3-yl acetate; <i>p</i> -menth-8- en- 3-yl acetate; Isopulegol acetate; Acetylated citronellal; Pulegol acetate; 5-Methyl-2-isopropenylcyclohexyl acetate
I119	Isoquercitrin, enzymatically modified	α -Glycosyl-isoquercitrin; Isoquercetin
I120	Isoquinoline	Quinoline(iso); 3,4-benzopyridine; 2-Azanaphthalene; 2-Benzazine; Benzo(o)pyridine; BenzoPyrine

Order	General Name	Synonyms
I121	Isovaleric acid	Active valeric acid; Valeric iso acid; 3-Methylbutyric acid; 3-Methylbutanoic acid; Delphinic acid; Isobutyl formic acid; Isopropyl lactic acid; β -Methyl butyric acid; valerianic acid; Isopentanoic acid
I122	Isobutyl 2-methylprop-2-enoate	Methacrylic acid, isobutyl ester; Isobutyl α -methacrylate; Isobutyl methacrylate; Isobutyl 2-methyl-2-propenoate; 2-Methylpropyl methacrylate; Isobutyl α -methacrylate; 2-Propenoic acid, 2-methyl-, 2-methylpropyl ester
I123	4-Isopropylphenol	Phenol, p-isopropyl-; p-Cumenol; p-Isopropylphenol; Australol; 4-(1-Methylethyl)phenol; 1-Hydroxy-4-isopropylbenzene; p-Cuminol ; Phenol, 4-(1-methylethyl)-
I124	Isopentyl heptanoate	Heptanoic acid, 3-methylbutyl ester; ; 3-methylbutyl heptanoate; iso-Amyl n-heptanoate
I125	Isobutyl hexadecanoate	Hexadecanoic acid, 2-methylpropyl ester
I126	Isopropyl hexadecanoate	Hexadecanoic acid, 1-methylethyl ester; Palmitic acid, isopropyl ester; Hexadecanoic acid, isopropyl ester; Isopropyl n-hexadecanoate; Isopropyl ester of hexadecanoic acid; 1-Methylethyl ester 1-methylethyl hexadecanoate; Hexadecanoic acid isopropyl n-hexadecanoate; 1-methylethyl hexadecanoate; 2-propyl hexadecanoate; Isopropyl palmitate
I127	α -Ionene	1,2,3,4-tetrahydro-1,1,6-trimethyl-naphthalene; Ionene; 1,1,6-trimethyltetraline; 1,1,6-Trimethyl-1,2,3,4-tetrahydronaphthalene; ionene (1,1,6-trimethyl-1,2,3,4-tetrahydronaphthalene); Naphthalene, tetrahydro-1,1,6-trimethyl-; Naphthalene, 1,2,3,4-tetrahydro-1,1,6-trimethyl-
I128	Isophytol	1-Hexadecen-3-ol, 3,7,11,15-tetramethyl-; Hexadec-1-en-3-ol, 3,7,11,15-tetramethyl-; 3,7,11,15-Tetramethyl-1-hexadecen-3-ol; 1-Hexadecene-3-ol, 3,7,11,15-tetramethyl

Order	General Name	Synonyms
I129	2-Isopropyl-5-methylphenyl acetate	O-Acetylthymol; Thymol acetate; Thymyl acetate; Thimyl acetate; Phenol, 5-methyl-2-(1-methylethyl)-, acetate
I130	Isobutyl lactate	Isobutyl 2-hydroxypropanoate; 2-methylpropyl 2-hydroxypropanoate; Propanoic acid, 2-hydroxy-, 2-methylpropyl ester
I131	Isobutyl isothiocyanate	Propane, 1-isothiocyanato-2-methyl-; Isothiocyanic acid, isobutyl ester; i-Butyl isothiocyanate; 2-Methylpropyl isothiocyanate; 1-Isothiocyanato-2-methylpropane
I132	3-Isopropylphenol	Phenol, m-isopropyl-; m-Cumenol; m-Isopropylphenol; 3-(1-Methylethyl)phenol; Isopropylphenol, meta; Phenol, 3-(1-methylethyl)-
I133	Isoamyl isothiocyanate	Butane, 1-isothiocyanato-3-methyl-; 1-Isothiocyanato-3-methylbutane
I134	2-Isopropylpyridine	Pyridine, 2-(1-methylethyl)-
I135	Isolongifolene	2H-2,4a-Methanonaphthalene, 1,3,4,5,6,7-hexahydro-1,1,5,5-tetramethyl-, (2S,4aR)-(-); 2H-2,4a-Methanonaphthalene, 1,3,4,5,6,7-hexahydro-1,1,5,5-tetramethyl-, (2S-cis)-; (-)-Isolongifoline; Isolongipholene; 2H-2,4a-methanonaphthalene, 1,3,4,5,6,7-hexahydro-1,1,5,5-tetramethyl-, (2s)-
I136	Isobutanal diethyl acetal	Isobutyraldehyde, diethyl acetal; Isobutyraldehyde diethyl acetal; 1,1-Diethoxy-2-methylpropane; 1,1-Diethoxyisobutane; Propane, 1,1-diethoxy-2-methyl-
I137	Isopentyl valerate	Valeric acid, 3-methylbutyl ester; iso-Amyl N-valerate; 3-Methylbutyl pentanoate; Pentanoic acid, 3-methylbutyl ester; Isopentyl pentanoate

Order	General Name	Synonyms
I138	Isopropyl isothiocyanate	Propane, 2-isothiocyanato-; 2-Isothiocyanatopropane
I139	[R-(E)]-5-Isopropyl-8-methylnona-6,8-dien-2-one	isopropyl methyl nonadienone
I140	Isoamyl decanoate(3-methylbutyl decanoate)	Pentadecanoic acid, 3-methylbutyl ester; iso-Amyl n-decanoate; Isopentyl decanoate;3-methylbutyl decanoate
I141	Isopropyl decanoate	Decanoic acid, 1-methylethyl ester;N-capric acid isopropyl ester
I142	Isobutyl 2-methylbutyrate	Butyric acid, 2-methyl-, isobutyl ester; Isobutyl 2-methylbutanoate; 2-Methyl-1-propyl 2-methylbutyrate; 2-methylpropyl 2-methylbutanoate;Butanoic acid, 2-methyl-, 2-methylpropyl ester
I143	Isovaleraldehyde diethyl acetal	Butane, 1,1-diethoxy-3-methyl-; Isovaleraldehyde, diethyl acetal; 3-Methylbutanal, diethyl acetal; 1,1-diethoxy-3-methyl butane; isopentanal diethyl acetal
I144	Isobutyl 10-undecenoate	isobutyl undecenoate
I145	Isopropyl octanoate	n-Octanoic acid isopropyl ester; Octanoic acid, 1-methylethyl ester; Octanoic acid, isopropyl ester; iso-Propyl n-octanoate;2-propyl octanoate
I146	Isobutyl octanoate	n-Caprylic acid isobutyl ester; Octanoic acid, 2-methylpropyl ester; iso-Butyl caprylate; Octanoic acid, isobutyl ester; iso-Butyl n-octanoate;2-methylpropyl octanoate
I147	Isopropyl crotonate	
I148	3-Isopropenylpentanedioic acid	
I149	1-Isobutoxy-1-ethoxyethane	

Order	General Name	Synonyms
I150	Isopropyl dodecanoate	Dodecanoic acid, 1-methylethyl ester; Isopropyl laurate
I151	Isopentyl 2-methylcrotonate	Isoamyl angelate; (Z)-2-Methyl-2-butenic acid 3-methylbutyl ester; 2-Butenoic acid, 2-methyl-, 3-methylbutylester
I152	Isobutyl valerate	Valeric acid, isobutyl ester; Isobutyl valerate; 2-Methyl-1-propyl n-valerate; 2-Methylpropyl valerate; Isobutyl pentanoate; Pentanoic acid, 2-methylpropyl ester
I153	1-Isopentyloxy-1-pentyloxyethane	
I154	Isopropyl valerate	Valeric acid, isopropyl ester; Pentanoic acid isopropyl ester; Isopropyl pentanoate; Pentanoic acid, 1-methylethyl ester
I155	2-Isobutyl-4-methyl-1,3-dioxolane	1,3-Dioxolane, 4-methyl-2-(2-methylpropyl)-; 2-Isobutyl-4-methyl-1,3-dioxolane
I156	Isodihydrocarveol	
I157	Isoamyl lactate(3-methylbutyl 2-hydroxypropanoate)	Propanoic acid, 2-hydroxy-, 3-methylbutyl ester; Isopentyl 2-hydroxypropanoate; 3-methylbutyl lactate
I158	Isobutyl tetradecanoate	Tetradecanoic acid, 2-methylpropyl ester; 2-methylpropyl tetradecanoate; Myristic acid isobutyl ester; Isobutyl myristate
I159	2-Isobutyl-4,5-dimethyloxazole	Oxazole, 4,5-dimethyl-2-(2-methylpropyl)-; 2-Isobutyl-4,5-dimethyl-1,3-oxazole; Oxazole, 4,5-dimethyl-2-isobutyl; 4,5-Dimethyl-2-isobutyloxazole
I160	Isobutyl decanoate	Decanoic acid, 2-methylpropyl ester; Decanoic acid, isobutyl ester; 2-methylpropyl decanoate; N-capric acid isobutyl ester
I161	S-Isopropyl 3-methylbut-2-enethioate	S-Isopropyl thiosenecioate; S-isopropyl 3-methylthiocrotonate; isopropyl methyl but enethioate
I162	Isobutyl dodecanoate	Lauric acid isobutyl ester; Dodecanoic acid, 2-methylpropyl ester; 2-methylpropyl dodecanoate; Isobutyl laurate
I163	Isovaleraldehyde glyceryl acetal	

Order	General Name	Synonyms
I164	Isopentyl tetradecanoate	
I165	1-Isobutoxy-1-ethoxypropane	
I166	2-Isopropyl-4-methyl-1,3-dioxolane	1,3-Dioxolane, 4-methyl-2-(1-methylethyl), trans
I167	1-Isobutoxy-1-isopentyloxyethane	
I168	Isopentyl hexadecanoate	3-Methylbutyl hexadecanoate
I169	1-Isobutoxy-1-ethoxy-3-methylbutane	
I170	1-Isopentyloxy-1-propoxyethane	
I171	1-Isopentyloxy-1-propoxypropane	
I172	2-(5-Isopropyl-2-methyl-tetrahydrothiophen-2-yl)ethylacetate	Tetrahydro-2-methyl-5-(1-methylethyl)-2-thiopheneethanolacetate
I173	Isoamyl phenethyl ether	(2-(3-Methylbutoxy)ethyl)benzene; 3-Methylbutyloxyethylbenzene; 1-(2-((3-Methylbutyl)oxy)ethyl)benzene; (2-(3-Methylbutoxy)ethyl)benzene; 2-(3-Methylbutoxy)ethylbenzene; Isopentylphenethylether; Greenether;2-(3-Methylbutoxy)ethylbenzene
I174	3-[3-(2-Isopropyl-5-methylcyclohexyl)-ureido]-butyric acid ethyl ester	Ethyl 3-(3-(2-isopropyl-5-methylcyclohexyl)ureido)butanoate; 3-[[[[5-Methyl-2-(1-methylethyl)cyclohexyl]amino]carbonyl]cmino]butanoic acid ethyl ester
I175	2-(5-Isopropyl-2-methyl-tetrahydrothiophen-2-yl)-ethanol	
I176	2-Isopropyl-4-methyl-3-thiazoline	2,5-Dihydro-2-isopropyl-4-methylthiazole; Thiazole, 2,5-dihydro-4-methyl-2-(1-methylethyl); 4-methyl-2-(propan-2-yl)-2,5-dihydro-1,3-thiazole
L002	Lauryl acetate	Acetate C-12; dodecanyl acetate; Dodecyl acetate; Lauryl ethanoate; Dodecanyl ethanoate; Lauryl acetate
L003	Lauryl alcohol	Alcohol C-12; Dodecyl; n-Dodecyl alcohol; 1-Dodecanol; Dodecyl carbinol; Dodecan-1-ol; Dodecyl alcohol; 1-

Order	General Name	Synonyms
		Dodecanol; Undecyl carbinol
L004	Levulinic acid	3-Acetylpropionic acid; Laevulinic acid; 3-Ketobutane-1-carboxylic acid; γ -Oxopentanoic acid; 4-oxovaleric acid; laevulinic acid; β -Acetylpropionic acid; γ -Ketovaleric acid; 4-Oxopentanoic acid; Acetopropionic acid; Levulinic acid
L005	d-Limonene	Cinene; citrene; Cajeputene; Carvene;dipentene; Kautschin; 1,8(9)-p-Menthadiene; p-Mentha-1,8-diene; 1-Methyl-4-isopropenyl-1-cyclohexene; d-1-Methyl-4- isopropenyl-1-cyclohexene
L006	l-Limonene	Levo-Limonene
L007	Linalool*	Linalol; 2,6-Dimethyl-2,7-octadiene-6-ol; Coriandrol (d-linalool from coriander oil); 3,7-Dimethyl-1,6-octadien-3-ol; dl-linalool (synthetic); 2,6-Dimethyl-octadien-2,7-ol-6
L008	Linalool oxide	2-Methyl-2-vinyl-5-(2-hydroxy-2-propyl_tetrahydrofuran; 5(2-Hydroxyisopropyl)-2- methyl-2-vinyltetrahydrofuran; 2-Furanmethanol, 5-ethenyltetrahydro- α,α -5- trimethyl-, cis; cis-trans-2-vinyl-2-methyl-5-(1'hydroxy-1'- methylethyl)- tetrahydrofuran; Linalool oxide (5-ring)
L009	Linalyl acetate*	1,5-Dimethyl-1-ethenylhex-4-enyl acetate; Licareol acetate; Linalool acetate; Bergamol; 3,7-Dimethyl-1,6-octadien-3-yl acetate
L010	Linalyl anthranilate	3,7-Dimethyl-1,6-octadien-3-yl anthranilate; Linalyl o-aminobenzoate; 3,7-Dimethyl- 1,6-octadien-3-yl-2-aminobenzoate; Linalyl 2-aminobenzoate
L011	Linalyl benzoate	1,5-Dimethyl-1-vinylhex-enyl benzoate; Linalool benzoate; 3,7-Dimethyl-1,6- octadien- 3-yl benzoate
L012	Linalyl butyrate	1,5-Dimethyl-1-ethenylhex-4-enyl butyrate; 3,7-Dimethyl-1,6-octadien-3-yl butyrate; 3,7-Dimethyl-1,6-octadien-3-yl butanoate; linalool isobutyrate; Linalyl-n-butyrate; linalool butanoate

Order	General Name	Synonyms
L013	Linalyl cinnamate	3,7-Dimethyl-1,6-octadien-3-yl cinnamate; 3,7-Dimethyl-1,6-octadien-3-yl 3-phenylpropenoate; 3,7-Dimethyl-1,6-octadien-3-yl β -phenylacrylate; Linalyl β -phenylacrylate; linalyl 3-phenylpropenoate; Linalyl 3-phenylpropenoate
L014	Linalyl formate	1,5-Dimethyl-1-ethenylhex-4-enyl formate; 3,7-Dimethyl-1,6-octadien-3-yl formic acid ester; Linalool formate; 3,7-Dimethyl-1,6-octadien-3-yl formate
L015	Linalyl hexanoate	1,5-Dimethyl-1-ethenylhex-4-enyl hexanoate; 3,7-dimethylocta-1,6-dien-3-yl hexanoate; linalyl capronate; linalyl caproate; Linalyl hexoate; linalyl hexylate; Linalyl hexoate; 3,7-Dimethyl-1,6-octadien-3-yl hexanoate
L016	Linalyl isobutyrate	1,5-Dimethyl-1-ethenylhex-4-enyl 3-methylpropionate; 3,7-Dimethylocta-1,6-dien-3-yl isobutylate; Linalool isobutyrate; Linalyl 3-methylpropionate; 3,7-Dimethyl-1,6-octadien-3-yl 2-methylpropanoate; Linalool 2-methylpropanoate; Linalyl 2-methylpropionate
L017	Linalyl isovalerate	1,5-Dimethyl-1-ethenylhex-4-enyl 3-methylbutyrate; 3,7-dimethylocta-1,6-dien-3-yl isovalerate; Linalyl isopentanoate; Linalyl 3-methylbutylate; Linalyl isovalerianate; 3,7-Dimethyl-1,6-octadien-3-yl isovalerate; 3,7-Dimethyl-1,6-octadien-3-yl 3-methylbutanoate; Linalyl 3-methylbutanoate
L018	Linalyl octanoate	1,5-Dimethyl-1-ethenylhex-3-enyl octanoate; 3,7-Dimethyl-1,6-octadien-3-yl octanoate; Linalool octanoate; Linalyl caprylate; Linalyl octoate; linalyl octylate
L019	Linalyl phenylacetate	Benzeneacetic acid, 1-ethenyl-1,5-dimethyl-4-hexenyl ester; 3,7-dimethyl-1,6-octadien-3-yl phenylacetate; Linalyl α -toluate; 1,5-dimethyl-1-vinylhex-4-enyl phenylacetate

Order	General Name	Synonyms
L020	Linalyl propionate	1,5-Dimethyl-1,6-octadien-3-yl propionate; Linalool propanoate; 3,7-Dimethyl-1,6- octadien-3-yl propionate; 3,7-Dimethyl-1,6-octadien-3-yl-propanoate
L021	linoleic acid and linolenic acid (mixture)	(9Z,12Z)-cotadeca-9,12-dienoic acid; 9,12-Octadecadienoic acid; 9,12,15- octadecatrienoic acid; Octadeca-9,12-dienoic acid
L022	Longifolene	1,4-Methanoazulene, decahydro-4,8,8-trimethyl-9-methylene-, (1S,3aR,4S,8aS)-(+)-; (+)-Longifolene; D-longifolene; 1,4-Methanoazulene, decahydro-4,8,8-trimethyl-9-methylene-; (+)-Longofolene; (+)-Longifolen;1,4-Methanoazulene, decahydro-4,8,8-trimethyl-9-methylene-, [1S-(1 α ,3a β ,4 α ,8a β)]-
L023	Lavandulol	4-Hexen-1-ol, 5-methyl-2-(1-methylethenyl)-, (r)-; 4-Hexen-1-ol, 2-isopropenyl-5-methyl-, (-)-; (R)-Lavandulol; 2-Isopropenyl-5-methyl-4-hexen-1-ol;(-)-Lavandulol
L024	N-Lactoyl ethanolamine	Propanamide, 2-hydroxy-N-(2-hydroxyethyl)-; N-(β -Hydroxyethyl)-2-hydroxypropionamide; N-(β -Hydroxyethyl)lactamide; N-Hydroxyaethylactamid; 2-Hydroxy-N-(2-hydroxyethyl)propanamide; Lactic acid monoethanolamide; Monoethanolamine lactic acid amide;N-(2-Hydroxyethyl)lactamide
L025	Linalyl valerate	Pentanoic acid, 1-ethenyl-1,5-dimethyl-4-hexenyl ester; Linalyl N-valerate; 1,5-Dimethyl-1-vinyl-4-hexenyl pentanoate
L026	Lavandulyl Acetate	
L027	Linalool oxide(5) acetate	

Order	General Name	Synonyms
L028	N-Lactoyl ethanolamine phosphate	N-(2-hydroxy-1-oxopropyl)ethanolamine O-phosphate; 2-[(2-hydroxypropanoyl)amino]ethyl dihydrogen phosphate; Phosphoric acid mono-[2-(2-hydroxypropionylamino)-ethyl] ester
L029	Lauric acid	Dodecanoic acid
L030	Linalool oxide pyranoid	Epoxylinool (pyranoid); 6-Ethenyl-2,2,6-trimethyl tetrahydro-2H-pyran-3-ol; 6-Ethenyl-2,2,6-trimethyltetrahydro-2H-pyran-3-ol; 6-Ethenyl-3,4,5,6-tetrahydro-2,2,6-trimethyl-2H-pyran-3-ol; 3-Hydroxy-2,2,6-trimethyl-6-vinyl tetrahydropyran; Linalool pyran oxide; Tetrahydro-2,2,6-trimethyl-6-vinyl-2H-pyran-3-ol; 2,2,6-Trimethyl-6-vinyl tetrahydro-2H-pyran-3-ol; 2,2,6-Trimethyl-6-vinyltetrahydro-2H-pyran-3-ol; 6-Ethenyl-2,2,6-trimethyloxan-3-ol
M001	Maltol*	3-Hydroxy-2-methyl-4h-pyran-4-one; 3-hydroxy-2-methyl- γ -pyrone; Palatone; Corps praline; Veltol; 3-Hydroxy-2-methyl-(1,4-pyran); 3-hydroxy-2-methyl-4-pyrone; larixinic acid; 2-Methyl pyromeconic acid; 4H-Pyran-4-one, 3-hydroxy-2-methyl; 2-Methyl pyromeconic acid
M002	Maltol propionate	4H-Pyran-4-one, 2-methyl-3-(1-oxopropoxy)-, Veltol propionate
M003	Maltyl isobutyrate	Maltyl 2-methylpropanoate; 2-methyl-4-pyran-3-yl 2-methylpropanoate; propanoic acid, 2-methyl-, 2-methyl-4-oxo-4H-pyran-3-yl ester; Maltol isobutyrate
M004	p-Menth-1-en-3-ol	1-Methyl-4-isopropyl-1-cyclohexen-3-ol; Neopiperitol(trans-form); piperitol
M005	p-Menth-1-en-9-al	Carvomenthenal
M006	p-Menth-3-en-1-ol	Terpinen-1-ol; 4-Isopropyl-1-methyl-3-cyclohexen-1-ol; 1-Terpinenol; $\Delta\beta$ -para- Menthen-1-ol; 1-Methyl-4-isopropyl-3-cyclohexen-1-ol; 1-Terpinenol; 1-Terpinenol; p-3-Methenol-1
M007	p-Menth-8-en-1-ol	1-Methyl-4-isopropenylcyclohexan-1-ol; β -Terpineol; 4-Isopropenyl-1-methyl-1-cyclohexanol
M008	p-Mentha-1,4(8)-dien-3-one	2-Cyclohexen-1-one, 3-methyl-6-(1-methylethylidene)-; 1-Methyl-4-isopropylidene-1-cyclohexen-3-one;

Order	General Name	Synonyms
		Piperitenone; 3-Methyl-6-(1-methylethylidene)cyclohex-2-en-1-one; Piperitenone; 4-Isopropylidene-1-methyl-1-cyclohexen-3-one
M009	p-Mentha-1,8-dien-7-al	1-Cyclohexene-1-carboxaldehyde, 4-(1-methylethenyl)-; Dihydrocuminic aldehyde; 4-isopropenyl-1-cyclohexene-1-carboxaldehyde; Perilla aldehyde; Perillaldehyde; p-mentha-1,8-dien-7-al
M010	p-Mentha-1,8-dien-7-ol	Dihydrocuminic alcohol; Hydrocumin alcohol; Menthadien-7-carbinol; 4-isopropenyl-1-cyclohexenecarbinol; Iso-carveol; Perilla alcohol; 1-Hydroxymethyl-4-isopropenyl-1-cyclohexene; Perillyl alcohol; Dihydrocuminy alcohol
M011	p-Mentha-1,8-dien-7-yl acetate	Perillyl acetate; Acetic acid, perillyl ester; Menthadien-7-carbinyl acetate; 1,8-para-Menthadien-7-yl acetate; 4-Isopropenyl-1-cyclohexene carbinol acetate; Dihydrocuminy acetate; 4-(1-Methylvinyl)cyclohex-1-ene-1-methylacetate; Perilla acetate; p-Mentha-1,8-dien-7-yl acetate
M012	p-Mentha-8-thiol-3-one	8-Mercapto-p-menthane-3-one; 8-Mercapto-3-p-menthanone; Thiomenthone; 8-Mercaptomenthone
M013	p-1(7)8-Menthadien-2-yl acetate, cis and trans isomers	cis- and trans-p-1(7),8-Menthadien-2-yl acetate; p-Mentha-1(7),8-dien-2-yl acetate, Acetic acid, p-1(7),8-menthadien-2-yl ester; Menthadienyl acetate; p-Mentha-1,8(10)-dien-9-yl acetate
M014	Menthadienol	p-Mentha-1,8(10)-dien-9-ol.
M015	p-Menthan-2-ol	Carvomenthol; Cyclohexanol, 2-Methyl-5-(1-methylethyl)-; Hexahydrocarvacrol; 3-Isopropyl-6-methylcyclohexanol; 1-Methyl-4-isopropyl-2-cyclohexanol

Order	General Name	Synonyms
M016	p-Menthan-2-one	Carvomenthone; Tetrahydrocarvone; 1-Methyl-4-isopropylcyclohexan-2-one; 5-Isopropyl-2-methylcyclohexanone; Tetrahydromenthone
M017	p-Menthane-3,8-diol	Cyclohexanemethanol,2-hydroxy- $\alpha,\alpha,4$ -trimethyl; 2-(2'-Hydroxypropan-2'-yl)-5- methylcyclohexanol; 2-Hydroxy- $\alpha,\alpha,4$ -trimethylcyclohexanmethanol
M018	1-p-Menthen-9-yl acetate	9-Acetoxy-1- <i>p</i> -menthene; 3-cyclohexene-1-menthanol, $\alpha,4$ -dimethyl-,acetate; <i>p</i> -menth-1-en-9-yl acetate
M019	1-p-Menthene-8-thiol	$\alpha,\alpha,4$ -Trimethyl-3-cyclohexene-1-methanethiol; p-Menth-1-ene-8-thiol
M020	Menthofuran	4,5,6,7-Tetrahydro-3,6-dimethylbenzofuran; 3,9-Epoxy- <i>p</i> -mentha-3,8-diene
M021	-Menthol*	Peppermint camphor; 5-Methyl-2-isopropylhexahydrophenol; 5-Methyl-2-isopropyl- cyclohexanol; menthacamphor; 1-Isopropyl-iso-4-methylcyclohexan-2-ol; 1-Propyl-iso- 4-methylcyclohexan-2-ol; Hexahydrothymol; 3- <i>p</i> -Menthanol; <i>p</i> -menthan-3-ol; 1-Methyl-4-isopropylcyclohexan-3-ol, 1-3- <i>p</i> -Menthanol; dl-3- <i>p</i> -Menthanol; 2-Isopropyl-5-methylcyclohexanol
M022	dl-Menthol*	
M023	d-neo-Menthol	2-Isopropyl-5-methylcyclohexanol; ; 2-Propyl-iso-5-methylcyclohexanol; 2-Isopropyl-5-methylcyclohexanol; d- β -Pulegomenthol; (+)-Neo-menthol
M024	(-)-Menthol 1- and 2-propylene glycol carbonate	Carbonic acide, 2-hydroxyethyl 5-methyl-2-(1-methylethyl)cyclohexyl ester; l-Menthol 1-(or 2)-propylene glycol carbonate; Menthol propylene glycol carbonate
M025	(-)-Menthol ethylene glycol carbonate	Carbonic acide, 2-hydroxyethyl 5-methyl-2-(1-methylethyl)cyclohexyl ester; l-menthol ethylene glycol carbonate;

Order	General Name	Synonyms
		2-Hydroxyethyl 5-methyl-2-(1-methylethyl)cyclohexyl carbonate; Menthol glycol carbonate
M026	D,L-Menthol-propylene glycol carbon	D,L-Menthol(+/-)-propylene glycol carbonate; Carbonic acid, 2-hydroxypropyl-5- methyl-2-(1-methylethyl)cyclohexylester; 5-Methyl-2-(1-methylethyl)-2-hydroxy propyl carbonic acid cyclohexyl ester
M027	Menthone	4-Isopropyl-1-methylcyclohexan-3-one; 4-Propyl-iso-1-methylcyclohexan-3-one; 2-Isopropyl-5-methyl-cyclohexanone; p-Menthan-3-one, trans-p-Menthan-3-one, trans-menthone; trans-2-Methyl-5-isopropylcyclohexanone
M028	DL-Menthone 1,2-glycerol ketal	1,4-Dioxaspiro[4,5]decane-2-methanol; l-Menthone 1,2-glycerol ketal; l-menthone 1,2-glyceryl ketal; 6-Isopropyl-9-methyl-1,4-dioxaspiro[4,5]decana-2-methanol; l-9-Methyl-6-(1-methylethyl)-1,4-dioxaspiro[4,5]decane-2-methanol
M029	(-)-Menthone-1,2-glycerol ketal	1,4-Dioxaspiro[4,5]decane-2-methanol; d,l-Menthone 1,2-glycerol ketal; d,l-Methyl- 6-(1-methylethyl)-1,4-dioxaspiro[4,5]fecane-2-mthanol; Frescolat racemic ; DL- Menthone-1,2-glycerol ketal
M030	cis and trans-Menthone-8-thioacetate	Menthon 8-thioacetate; (S)-menthon-8-yl thioacetate; menthone thioacetate; 8-Acetylthio-p-menthan-3-one; 8-Acetylthiomenthan-3-one; cis-1-methyl-1-(4-methyl- 2-oxocyclohexyl)ethyl thioacetate; cis-2-(1-Acetylthio-1-methylethyl)- 5- methylcyclohexanone; trans-1-methyl-1-(4-methyl-2-oxocyclohexyl)ethyl thioacetate; trans-2-(1-Acetylthio-1-methylethyl)-5-methylcyclohexanone
M031	3-(L-Menthoxo)-2-methylpropane-1,2-diol	3-l-Menthoxo-2-methylpropan-1,2-diol
M032	2-(L-Menthoxo)ethanol	Ethanol, 2-[[5-methyl-2-(1-methylethyl)cyclohexy]-oxy]-; 2-(p-Menthan-3-yloxy) ethanol; 3-(2-Hydroxyethoxy)-p-menthane; Coolact5

Order	General Name	Synonyms
M033	Menthyl acetate	p-Menthan-3-yl acetate; 5-Methyl-2-(1-methylethyl)cyclohexyl acetate; l-p-Menth-3-yl acetate; Menthol acetate; 1-Isopropyl-4-methylcyclohex-2-yl acetate
M034	Menthyl isovalerate	Menthyl 3-methylbutanoate; Menthyl isovalerianate; Menthyl isopentanoate; 1-Isopropyl-4-methylcyclohex-2-yl 3-methylbutanoate; Menthol isovalerate; 1-propyl- iso-4-methylcyclohex-2-yl 3 methylbutanoate; p-Menth-3-yl isovalerate; validol
M035	l-Menthyl lactate	Frescolate; α -Hydroxypropanoic acid, 5-methyl-2-(1-methylethyl)cyclohexyl ester; (-)-p-Menthan-3-yl lactate; propanoic acid, 2-hydroxy-, 5-methyl-2-(1-methylethyl) cyclohexyl ester; (-)-Menthyl lactate; 5-Methyl-2-(1-methylethyl)cyclohexyl α -hydroxypropanoate; l-p-Menthan-3-yl lactate
M036	L-Menthyl methyl ether	Cyclohexane,2-methoxy-4-methyl-1-(1-methylethyl)-,(1S,2R,4R)-; 1-Isopropyl-2- methoxy-4-methylcyclohexane; 2-Isopropyl-5-methylcyclohexyl methyl ether; 1-Menthyl methyl ether
M037	Menthyl pyrrolidone carboxylate	D- and L-proline, 5-oxo, 5-methyl-2-(1-methylethyl)cyclohexyl ester; 2-Isopropyl-5-methylcyclohexyl 5-oxo-2-pyrrolidine carboxylate; Questice
M038	Menthyl valerate	Pentanoic acid, (1R,2S,5R)-5-methyl-2-(1-methylethyl)cyclohexyl ester; Methyl pentanoate; Methyl valerianate
M039	3-Mercapto-2-butanone	

Order	General Name	Synonyms
M040	erythro and threo-3-Mercapto-2-methylbutan-1-ol	1-Butanol, 3-mercapto-2-methyl; 3-Mercapto-2-methylbutyl alcohol
M041	3-Mercapto-2-methylpentan-1-ol (racemic)	
M042	3-Mercapto-2-methylpentanal	
M043	3-Mercapto-2-pentanone	
M044	4-Mercapto-2-pentanone	2-Pentanone, 4-mercapto-4-Mercaptopentan-2-one
M045	1-Mercapto-2-propanone	Mercaptoacetone
M046	2-Mercapto-3-butanol	2-Butanol, 3-mercapto-, (R [*] -, S [*] -); 2-Hydroxy-3-butanethiol; 3-hydroxy-2-butanethiol; 3-Mercapto-2-butanol; 3-Mercaptobutan-2-ol
M047	3-Mercapto-3-methyl-1-butanol	1-Butanol, 3-mercapto-3-methyl-; 3-Methyl-3-mercaptobutyl alcohol; 3-Mercapto-3-methylbutyl alcohol
M048	3-Mercapto-3-methylbutyl formate	3-Methyl-3-thiobutyl formate; 1-Butanol, 3-mercapto-3-methyl, formate ester; 3-Methyl-3-mercaptobutyl formate
M049	(+/-)-4-Mercapto-4-methyl-2-pentanol	2-Pentanol, 4-mercapto-4-methyl-
M050	4-Mercapto-4-methyl-2-pentanone	Thiomethyl pentanone-4,4,2; 2-Mercapto-2-methylpentan-4-one
M051	2-Mercaptoanisole	2-Methoxythiophenol; Benzenethiol, o-methoxy-; Methoxybenzenethiol; o-Methoxythiophenol; Thioguaiacol; 2-Methoxybenzenethiol
M052	3-Mercaptohexanol	3-Mercapto-1-hexanol, 3-Thiohexan-1-ol; 3-Thiohexanol; 3-Thiohexanol
M053	3-Mercaptohexyl acetate	3-Thiohexyl acetate; 3-Thiohexyl ethanoate

Order	General Name	Synonyms
M054	3-Mercaptohexyl butyrate	3-Thiohexyl butrate; 3-Thiohexyl butanoate
M055	3-Mercaptohexyl hexanoate	3-Mercaptohexyl caproate; 3-Thiohexyl caoroate; 3-thio-1-hexyl caproate; 3-Thio-1-hexyl hexanoate
M056	2-(Mercaptomethyl)pyrazine	Mercaptomethylpyrazine; Pyrazine methanethiol; Pyrazinyl methylmercaptan
M057	(+/-)-2-Mercaptomethylpentan-1-ol	(+/-)-2-Mercapto-2-methylpentan-1-ol
M058	2-, 3- and 10-Mercaptopinane	Mixture of 2,6,6 trimethyl-bicyclo[3.1.1]heptane-(2,3 and 10)-thiols; Bicyclo[3.1.1]heptane-2-thiol, 2,6,6-trimethyl-; pinanethiol; Pinanyl mercaptan
M059	2-Mercaptopropionic acid	Thiolactic acid; α -Mercaptopropanoic acid; 2-Thiolpropionic acid
M060	Methionyl butyrate	1-Propanol, 3-(methylthio)-, butyrate; Butyric acid, 3-(methylthio)propyl ester; 3-(Methylthio)propyl butyrate
M061	3-(1-Methoxy)-1,2-propanediol	3-1-Menthoxyp propane-1,2-diol; 3-L-Menthoxyp propane-1,2-diol; 3-l-(p-Menthane-3- yloxy)-1,2-propanediol
M062	trans- and cis-1-Methoxy-1-decene	(E)- and (Z)-1-Methoxy-1-decene; 1-Decene, 1-methoxy- (E,Z)-; Decanal methyl enol ether
M063	4-Methoxy-2-methyl-2-butanethiol	4-Methoxy-2-methylbutanethiol; 2-Butanethiol, 4-methoxy-2-methyl-
M064	2-Methoxy-3-(1-methylpropyl)pyrazine	2-Methoxy-3- <i>sec</i> -butylpyrazine; 2-(1-Methylpropyl)-3-methoxypyrazine; 2-Sec- butyl- 3-methoxypyrazine, 2-(2-Bytyl)-3-methoxypyrazine; 2-But-2-yl-3-methoxypyrazine; 2-Methoxy-3-(1-methylpropyl)-cyclohexanone
M065	(S1)-Methoxy-3-heptanethiol	3-Heptanethiol, 1-methoxy-, (3S); Aruscol
M066	2,5 or 6-Methoxy-3-methylpyrazine(mixture of isomers)	2-Methoxy-3-methylpyrazine; 2-Methoxy-5-methylpyrazine; 2-methoxy-6- methylpyrazine; Mixture of 2-methoxy-3-methylpyrazine; Methylmethoxypyrazine

Order	General Name	Synonyms
M067	1-Methoxy-4-(1-propenyl)benzene	Anethole; p-Propylanisole; Isoestragole; p-Propylphenyl methylether; Propenylanisole;
M068	N1-(2-Methoxy-4-methylbenzyl)-N2-(2-(pyridin-2-yl)ethyl)oxalamide	Ethanediamide, N-[(2-methoxy-4-methylphenyl)methyl]-N-[2-(2-pyridinyl)ethyl]-
M069	N1-(2-Methoxy-4-methylbenzyl)-N2-(2-(5-methylpyridin-2-yl)ethyl)oxalamide	Ethanediamide, N-[(2-methoxy-4-methylphenyl)methyl]-N-[2-(5-methyl-2-pyridinyl)ethyl]-
M070	2-Methoxy-4-methylphenol	3-Methoxy-4-hydroxytoluene; Homocatechol monoethyl ether; 1-Hydroxy-2-methoxy-4-methylbenzene; Valspice; Cresol; 4-Hydroxy-3-methyl-1-methyl benzene; 2-Methoxy- p-cresol; 4-methylguaiacol
M071	2-Methoxy-4-propylphenol	Dihydroeugenol; Phenol, 2-methoxy-4-propyl-; 4-Propylguaiacol; 5-propyl- <i>o</i> -hydroxyanisole; 4-Propyl- <i>o</i> -methoxyphenol; 4-Propyl-ortho-Methoxyphenol; 5-Propyl-ortho-Hydroxyanisole
M072	2-Methoxy-4-vinylphenol	4-Hydroxy-3-methoxystyrene; <i>p</i> -vinylguaiacol / 4-Hydroxy-3-methoxystyrene; Phenol, 4-ethenyl-2-methoxy-; <i>p</i> -Vinylcatechol- <i>o</i> -methyl ether; <i>p</i> -Vinylguaiacol; Vinyl guaiacol; <i>p</i> -Vinylcatechol- <i>o</i> -methyl ether
M073	2-Methoxyacetophenone	1-(2-Methoxyphenyl)ethanone; 2-Acetylanisole; 2-Methoxyphenyl methyl ketone; Methyl 2-methoxyphenyl ketone; Methyl <i>o</i> -methoxyphenyl ketone; <i>o</i> -Acetylanisole; <i>o</i> -Methoxyacetophenone
M074	<i>p</i> -Methoxy- α -methylcinnamaldehyde	3-(4-Methoxyphenyl)-2-methylprop-2-enal; 3-(<i>p</i> -Methoxyphenyl)-2-methyl-2-propenal; 4'-Methoxy-2-methylcinnamaldehyde; α -Methyl- <i>p</i> -methoxycinnamaldehyde; 3-(2-Methoxyphenyl)-2-methyl-2-propenal; α -Methylmethoxycinnamic aldehyde
M075	<i>p</i> -Methoxybenzaldehyde	<i>p</i> -Anisaldehyde; Anisic aldehyde; aubepine; 4-Methoxybenzaldehyde; Aubepine; Aubepine liquid

Order	General Name	Synonyms
M076	2-Methoxybenzoic acid	o-Anisic acid; o-Methoxybenzoic acid; Salicylic acid methyl ether
M077	3-Methoxybenzoic acid	3-Anisic acid; m-Anisic acid; m-Methoxybenzoic acid
M078	4-Methoxybenzoic acid	4-Anisic acid; Anisic acid; p-Anisic acid, p-Methoxybenzoic acid; Draconic acid
M079	o-Methoxycinnamaldehyde	β -(o-Methoxyphenyl) acrolein; 3-(o-methoxyphenyl)-2-propenal; Methoxycinnamaldehyde; 3-(4-Methoxyphenyl)-2-propenal; 2-propenal, 3-(4-methoxy0-phenyl)-; 2'-Methoxycinnamaldehyde; β -o-Methoxyphenyl acrolein; 3-o-Methoxyphenyl-2-propenal; 3-(2-Methoxyphenyl)-2-propenal
M080	p-Methoxycinnamaldehyde	3-(4-Methoxyphenyl)-2-propenal; 4-Methoxycinnamaldehyde; p-Cumaric aldehyde methyl ether; β -(p-Methoxyphenyl)-acrolein; 3-(p-Methoxyphenyl)-propenal; 3-(p-Methoxyphenyl)propen-2-al-1; 3-4-Methoxyphenyl-2-propenal
M081	1-(p-Methoxyphenyl)-1-penten-3-one	Ethone; <i>p</i> -Methoxystyryl ethyl ketone; α -Methyl anisylacetone; α -Methylanisylideneacetone; 1-(4-Methoxyphenyl)-1-penten-3-one; amethylanisylidene acetone; 1-(4-Methoxyphenyl)pent-1-en-3-one
M082	4-(p-Methoxyphenyl)-2-butanone	p-Methoxybenzylacetone; Methyl oxanone; Bramble ketone; Frambinonmethylether; Ketanone; Anisyl acetone; Rambinone methylether; p-Methoxy phenylbutanone; Raspberry ketone methylether; 4-(4-Methoxyphenyl)-2-butanone, Methyloxanone; Raspberry ketone
M083	1-(p-Methoxyphenyl)-2-propanone	4-Methoxyphenylacetone; Anisic ketone; anisketone; Anisyl methyl ketone; p-Methoxyphenylacetone; 1-(4-Methoxyphenyl)-2-propanone; 3-(4-Methoxyphenyl)-propan-2-one; Anisic ketone

Order	General Name	Synonyms
M084	1-(4-Methoxyphenyl)-4-methyl-1-penten-3-one	Isopropyl 4-methoxystyryl ketone; α,α -Dimethylanisylacetone; p-Methoxystyryl isopropyl ketone; Isopropyl p-methoxystyryl ketone; Methoxystyryl isopropyl ketone
M085	Methoxypyrazine	2-Methoxy-1,4-diazine; 2-methoxypyrazine
M086	Methyl (E)-2-(Z)-4-decadienoate	Methyl deca-2,4-dienoate
M087	Methyl (methylthio) acetate	Acetic acid, (methylthio)-, methyl ester; Methyl 2-(methylthio)acetate; (Methylthio)acetic acid methyl ester
M088	Methyl 10-undecenoate	10-Undecenoic acid, methyl ester; Methyl undec-10-enoate; Methyl undecylenate
M089	Methyl 1-acetoxycyclohexyl ketone	1-Acetylcyclohexyl acetate; 1-Acetoxy-1-acetylcyclohexane; 1-Acetoxycyclohexyl acetate; ethanone, 1-[1-(acetyloxy)cyclohexyl]-
M090	Methyl 1-propenyl disulfide	Methyl propenyl disulfide; Disulfide, methyl 1-propenyl-; Methylthio-1-propene; 1-propenyl methyl disulfide; 1-Propenyl methyl disulphide
M091	Methyl 2-furoate	Methyl furoate; Furan- α -carboxylic acid, methyl ester; Methyl-2-furoate; methyl pyromucate; 2-Furoic acid
M092	Methyl 2-hydroxy-4-methylpentanoate	Methyl 2-hydroxy-4-methylvalerate; Methyl 2-hydroxyisocaproate; Pentanoic acid, 2-hydroxy-4-methyl-, methyl ester
M093	Methyl 2-methyl-2-propenoate	2-Propenoic acid, 2-methyl-, methyl ester; Methyl 2-methacrylate, 2-(methoxycarbonyl)-1-propene
M094	Methyl 2-methyl-3-furyl disulfide	Furan, 2-methyl-3-(methylthio)-; 2-Methyl-3-(methylthio)furan, 2-Methyl-3-furyl methyl disulfide

Order	General Name	Synonyms
M095	S-Methyl 2-methylbutanethioate	Methyl 2-(methylthio)butyrate; Methylthiol 2-methylbutyrate
M096	Methyl 2-methylbutyrate	Butanoic acid, 2-methyl-, methyl ester; Methyl-2-methylbutanoate; Methyl methylethylacetate
M097	Methyl 2-methylpentanoate	Methyl 2-methylvalerate; Pentanoic acid, 2-methyl-, methyl ester
M098	Methyl 2-nonenoate	
M099	Methyl 2-nonenonate	Methyl non-2-enoate; Methyl nonylenate; Methyl nonylenoate
M100	Methyl 2-oxo-3-methylpentanoate	Methyl 2-keto-3-methylvalerate; methyl 3-methyl-2-oxovalerate; Pentanoic acid, 3-methyl-2-oxo-, methyl ester; Methyl 2-oxo-3-methylvalerate; Methyl 2-keto-3-methylpentanoate
M101	Methyl 2-pyrrolyl ketone	2-Pyrrolyl methyl ketone; 2-Acetyl pyrrole; 2-Acetopyrrole; Methyl-2-pyrrolyl ketone
M102	Methyl 2-undecynoate	Methyl decine carbonate; Methyl decyne carbonate; Methyl undec-2-ynoate; Methyl octyl propiolate
M103	Methyl 3-(methylthio)butanoate	3-(Methylthio)butyric acid methyl ester; Butanoic acid, 3-(methylthio)-, methyl ester; 3-Methylsulfanylbutyric acid methyl ester
M104	Methyl 3,7-dimethyl-6-octenoate	Methyl citronellate ; Methyl-3,7-dimethyl-oct-6-enoate
M105	Methyl 3-hexenoate	o-Hexylhexanolide; Methyl hydrosorbate
M106	Methyl 3-hydroxyhexanoate	Hexanoic acid, 3-hydroxy-, methyl ester; Methyl β -hydroxycaproate; Methyl β -hydroxyhexanoate; Methyl 3-hydroxycaproate
M107	Methyl 3-mercaptobutanoate	Butanoic acid, 3-mercapto-, methyl ester; 3-Mercaptobutanoic acid methyl ester

Order	General Name	Synonyms
M108	S-Methyl 3-methylbutanethioate	Methyl thioisovalerate; S-methyl 3-methylbutyrate; Methane thioisopentanoate
M109	Methyl 3-methylthiopropionate	Methyl β -methylthiopropionate; Methylmercaptomethylpropionate; Methyl- β - methylmercaptopropionate; Methyl- β -methylthiopropionate; β -Methylthiopropionic acid, methyl ester ; Methyl β -Methiopropionate
M110	Methyl 3-nonenoate	3-Nonenoic acid, methyl ester; Methyl non-3-enoate
M111	Methyl 3-phenylpropionate	Methyl dihydrocinnamate; Methyl hydrocinnamate; Methyl phenyl propionate
M112	Methyl 4-(methylthio)butyrate	Methyl 4-(methylmercapto)butyrate; Mixture of methyl 9,12-octadecadienoate and methyl 9,12,15-octadecatrienoate; Methyl γ -methyl mercapto butyrate; Methyl γ -(methylthio)butyrate
M113	S-Methyl 4-methylpentanethioate	
M114	Methyl 4-methylvalerate	Methyl isobutyrylacetate; Methyl isocaproate; Methyl-4-methyl pentanoate; Methyl isobutyl acetate
M115	Methyl 4-phenylbutyrate	Methyl γ -phenylbutyrate; γ -Phenylbutyric acid, methyl ester
M116	(+/-)-Methyl 5-acetoxyhexanoate	Hexanoic acid, 5-(acetyloxy)-,methyl ester; 5-Acetoxyhexanoic acid methyl ester
M117	Methyl 9-undecenoate	methyl undec-9-enoate; Methyl undecylenate; Methyl 9-hendecenoate; Methyl 9- undecylenate
M118	Methyl acetate	Methyl ethanoate
M119	Methyl anisate	Methyl p-anisate; Methyl p-methoxybenzoate; Methyl 4-methoxybenzoate
M120	Methyl anthranilate *	o-Amino methyl benzoate; Methyl 2-aminobenzoate; methyl o-aminobenzoate
M121	Methyl benzoate	Methyl benzenecarboxylate; Niobe oil

Order	General Name	Synonyms
M122	S-Methyl benzothioate	Methanethiol, Benzoate; Methylthiyl benzoate; Methane thiobenzoate; S-Methyl thiobenzoate
M123	Methyl benzyl disulfide	Benzylidithiomethane; Benzyl methyl disulfide; disulfide, phenylmethyl methyl; Methyl phenylmethyl disulfide
M124	Methyl β -naphthyl ketone*	Cetone d; Oranger crystals; β -Acetylnaphthalene; 2'-Acetonaphthone; 2-acetyl- naphthalene; methyl naphthyl ketone; β -naphthyl methyl ketone; 1-(2-Naphthyl) ethanone; Methyl 2-naphthyl ketone
M125	4-Methyl biphenyl	p-Methyldiphenyl; p-methylphenylbenzene; 4-Methyl-1,1'-biphenyl; Phenyl-p-tolyl; p-Phenyltoluene
M126	Methyl butyrate	Methyl butanoate
M127	Methyl caproate	Methyl hexanoate; Methyl hexanoate; methyl hexylate
M128	Methyl cinnamate*	Methyl-3-phenyl propenoate; Methyl-3-phenyl prop-2-enoate
M129	Methyl cis-3-hexenoate	Methyl (Z)-3-hexenoate
M130	Methyl cis-4-octenoate	(Z)-methyl oct-4-enoate; Methyl oct-4(cis)-enoate
M131	Methyl cis-5-octenoate	5-Octenoic acid, methyl ester, (5Z)
M132	Methyl cyclohexanecarboxylate	Cyclohexanecarboxylic acid, methyl ester
M133	γ -Methyl decalactone	4-Methyl-4-decanolide; 5-Hexyldihydro-5-methyl-2(3H)-furanone; 5-Hexyl-5- methyl-dihydrofuran-2(3H)-one; Dihydrojasmonone lactone; 2(3H)-furanone, 5-hexyldihydro-5-methyl-; 4-Methyldecanolide; lactojasmonone; Methyl γ -decalactone; Dihydrojasmonone lactone
M134	Methyl dihydrojasmonate	hedione; Methyl 3-oxo-2-pentyl-1-cyclopentylacetate; 2-Amylcyclopentanone acetic acid, methyl ester; Methyl

Order	General Name	Synonyms
		hydrojasmonate; Methyl-(2-amyl-3-oxocyclopentyl); methyl-2-(-pentyl-3-oxo-1-cyclopentyl)acetate; Methyl epidihydrojasnone; Jasmonic acid, (E)-dihydro-, methyl ester
M135	Methyl disulfide	dimethyl disulfide
M136	Methyl ethyl sulfide	(Methylthio)Ethane; 1-(methylthio)Ethane; 2-Thiabutane; Ethyl methyl sulfide; Ethyl methyl thioether
M137	Methyl ethyl trisulfide	Ethyl methyl trisulfide, 2,3,4-Trithiahexane; 2,3,4-Trithiohexane
M138	Methyl furfuryl disulfide	Methyl 2-furylmethyl disulfide; Furfuryl methyl disulfide
M139	Methyl heptanoate	Methyl heptoate; Methyl heptylate; Methyl oenanthate
M140	Methyl heptin cabonate	Methyl 2-octynoate; Methyl heptine carbonate; Methyl heptyne carbonate; Methyl oct-2-ynoate; Methyl pentylpropiolate
M141	Methyl hex-2-enoate	Methyl- α,β -hexanoate; methyl- β -propylacrylate
M142	S-Methyl hexanethioate	
M143	Methyl isobutyrate	Methyl dimethylacetate; Methyl-2-methylpropanoate
M144	Methyl isopentyl disulfide	Disulfide, isopentyl methyl; Isoamyl methyl disulfide; Isopentyl methyl disulfide; Methyl isopentyl disulfide
M145	Methyl isovalerate	Methyl isovalerianate; Methyl isopentanoate; Methyl 3-methylbutyrate; Methyl 3-methylbutanoate; Methyl β -methyl butyrate

Order	General Name	Synonyms
M146	Methyl jasmonate	Methyl 3-oxo-2-pent-2-enyl-1-cyclopentylacetate; 2-Pentenyl cyclopentanone-3- acetic acid, methyl ester; 2-(cis-Penten-2'-yl)-3-oxo-cyclopentane acetic acid, methyl ester; methyl (2-pent-2-enyl-3-oxo-1-cyclopentyl) acetate; Methyl epi-jasmonate
M147	Methyl laurate	Methyl dodecanoate; Methyl dodecylate; Methyl laurate
M148	Methyl linoleate and methyl linolenate (mixture)	Methyl linoleate; Methyl linolenate, methyl linoleate mixture; methyl 9,12- octadecadienoate; methyl 9,12,15-octadecatrienoate mixture; 9,12,15-Octadecatrienoic acid, methyl ester, (Z,Z,Z,-); Linoleic and linolenic methyl acids; Methyl octadeca-9(cis),12(cis)-dienoate
M149	Methyl mercaptan	Thiomethyl alcohol; methyl sulfhydrate; Mercaptomethane; Methanethiol; Methylmercaptan
M150	Methyl myristate	Methyl tetradecanoate; Methyl n-tetradecanoate; Methyl myristate
M151	Methyl N,N-dimethylantranilate	Benzoic acid, 2-(dimethylamino)-, methyl ester; Anthranilic acid, N,N-dimethyl-, methyl ester; Methyl 2-(dimethylamino)benzoate; Methyl o-(dimethylamino)benzoate
M152	Methyl N-acetylantranilate	Benzoic acid, 2-(acetylamino)-, methyl ester; Anthranilic acid, N-acetyl-, methyl ester; Methyl 2-(acetylamino)benzoate; Methyl 2-acetamidobenzoate; Methyl N- acetoantranilate; o-(Methoxycarbonyl)acetanilide; o-Acetamidobenzoic acid methyl ester
M153	Methyl N-formylantranilate	Benzoic acid, 2-(formylamino)-, methyl ester; Methyl o-formamidobenzoate; N-Formylantranilic acid, methyl ester
M154	Methyl nicotinate	3-Carbomethoxypyridine; Methyl 3-pyridinecarboxylate; 3-Pyridinecarboxylic acid, methyl ester

Order	General Name	Synonyms
M155	Methyl N-methylantranilate*	Dimethyl anthranilate
M156	Methyl nonanoate	Methyl nonylate; Methyl pelargonate; Methyl nonylate
M157	Methyl octanoate	Methyl caprylate; Methyl octoate; Methyl octylate
M158	Methyl octyne carbonate	Methyl 2-nonynoate; Methyl octine carbonate; Methyl octyne carbonate
M159	Methyl o-methoxybenzoate	o-Methoxy methyl benzoate; Methyl salicylate o-methyl ether; Dimethyl salicylate; Methyl o-anisate; Methyl 2-methoxybenzoate; Methyl salicylate methyl ether; o-Methoxybenzoic acid methyl ester
M160	Methyl phenethyl ether	Pandanol; 2-Methoxyethyl benzene; Phenylethyl methyl ether; Phenylethylmethylether
M161	Methyl phenyl disulfide	Phenyl methyl disulfide
M162	Methyl phenyl sulfide	(methylthio)Benzene; 1-phenyl-1-thioethane; Methyl phenyl thioether; Phenyl methyl sulfide; Phenylthiomethane; Thioanisol; Thioanisol; Thioanisole; Benzene, (methylthio)-; Sulfide, methyl phenyl-
M163	Methyl phenylacetate	Phenylacetic acid methyl ester; Methyl α -toluate
M164	Methyl p-hydroxybenzoate	Methylparaben
M165	S-Methyl propanethioate	Propanethioic acid, S-methyl ester; S-Methyl thiopropionate
M166	Methyl propionate	Methyl propanoate

Order	General Name	Synonyms
M167	Methyl propyl disulfide	Methyldithiopropene; Methyl n-propyl disulfide; Propyl methyl disulfide
M168	Methyl propyl trisulfide	Propyl methyl trisulfide; Methyl trithio propane; Propyl methyl trisulphide
M169	3-(2-Methyl propyl) pyridine	3-Butyl iso pyridine; 3-Isobutyl pyridine; 3-ButylPyridine
M170	2-(2-Methyl propyl)pyridine	2-Butyl iso pyridine; 2-Isobutyl pyridine; 2-ButylPyridine
M171	Methyl p-tert-butylphenylacetate	<i>p-tert</i> -Butylphenylacetic acid, methyl ester; Methyl (4-(1,1-dimethylethyl)phenyl)- acetate
M172	Methyl salicylate*	Methyl 2-hydroxybenzoate; synthetic wintergreen oil; synthetic sweet birch oil; synthetic teaberry oil; Methyl o-hydroxybenzoate
M173	Methyl sorbate	2,4-Hexadienoic acid, methyl ester; methyl 2,4-hexadienoate; methyl (E,E)-2,4- hexadienoate; Methyl hexa-2,4-dienoate
M174	Methyl sulfide	2-Thiapropene; Thiobismethane; Dimethyl sulfide
M175	S-Methyl thioacetate	S-methyl acetothioate; Methanethiol acetate; S-methyl ethanethioate
M176	Methyl thiobutyrate	S-methyl butanethioate; Methylthiol n-butyrate; Thiobutyric acid, methyl ester; Mathanethiol n-butyrate
M177	S-Methyl thiofuroate	Methyl 2-thiofuroate; Methanethiol furoate; Methyl thiofuroate; Thiofuroic acid, methylester; S-methyl 2-furanthiocarboxylate; Furoylthiomethane; Methyl thio-2-furoate
M178	Methyl trans-2-octenoate	Methyl (E)-2-octenoate; 2-Octenoic acid, methyl ester, (E)-; Methyl-2-octenoate; Methyl oct-2(trans)-enoate
M179	Methyl valerate	Methyl pentanoate; Methyl-n-valerate; methyl valerianate
M180	3-Methyl-1,2,4-trithiane	1,2,4-Trithiane, 3-methyl, 3-Methyl-1,2,4-trithiacyclohexane

Order	General Name	Synonyms
M181	2-Methyl-1,3-cyclohexadiene	Dihydrotoluene(1,3); dihydrotoluene(delta1,3)
M182	2-Methyl-1,3-dithiolane	
M183	2-Methyl-1-butanethiol	Amyl mercaptan; 2-Methylbutyl mercaptan; Thioamyl alcohol
M184	(+/-)-2-Methyl-1-butanol	(+/-)2-Methyl-1-butanol; 2-Methyl-n-butanol; 2-Methylbutyl alcohol; Active amyl alcohol; Active primary amyl alcohol; Primary active amyl alcohol; sec-Butylcarbinol
M185	3-Methyl-1-cyclopentadecanone	<i>d,l</i> -Muscone; methyloxaltone; 3-emthylcyclopentadecanone; 3- Methylcyclopentadecan-1-one; Muscone
M186	1-Methyl-1-cyclopenten-3-one	3-Methyl-2-cyclopenten-1-one; 1-Methyl-1-cyclopenten-3-one
M187	2-Methyl-1-methylthio-2-butene	2-Methyl-1-methylsulfanyl-but-2-ene; Methyl 2-methyl-2-butenyl sulfi de
M188	3-Methyl-1-pentanol	3-methylpentan-1-ol; 2-ethyl-4-butanol; 1-pentanol, 3-methyl-
M189	1-Methyl-1-phenethyl isobutyrate	2-phenylpropan-2-yl isobutyrate; α,α -dimethylbenzyl 2-methylpropanoate; Phenyl dimethyl carbonyl isobutyrate; Dimethyl phenyl carbonyl isobutyrate; Phenylpropan-2-yl 2-methylpropionate; α,α -Dimethylbenzyl isobutyrate; 2-Phenylpropan-2-yl 2-methylpropanoate
M190	4-Methyl-1-phenyl-2-pentanone	Benzyl isobutyl ketone; Isobutyl benzyl ketone; Benzyl 2-methylpropyl ketone
M191	2-Methyl-1-propanethiol	Isobutyl nercaptan
M192	(2S-trans)-5 Methyl-2-(1-methylethyl)cyclohexanone	l-Menthone
M193	3-Methyl-2-(2-pentenyl)-2-cyclopenten-1-one	cis Jasmone; Jasmone; 3-Methyl-2-pent-2-enylcyclopent-2-en-1-one; 3- Methyl-2- (pent-2(cis)-enyl)cyclopent-2-

Order	General Name	Synonyms
		en-1-one
M194	3-Methyl-2(3-methylbut-2-enyl)furan	γ -Clausenane; Rosefuran; 2-(3-Methyl-2-butenyl)-3-methylfuran; Furan, 3-methyl- 2-(3-methyl-2-butenyl)-; 3-Methyl-2(3-methylbut-2-en-1-yl)furan
M195	2-Methyl-2-(methyldithio)propanal	2-Methyl-2-(methyldithio)propionaldehyde; 2-(Methyldithio)isobutyraldehyde
M196	1-Methyl-2,3-cyclohexadione	3-Methyl-1,2-cyclohexanedione; 2-methyl-3,4-cyclohexanedione; 3- Methylcyclohexan-1,2-dione
M197	5-Methyl-2,3-hexanedione	2-Methyl-4,5-hexanedione; acetyl isovaleryl; Isobutyl methyl diketone; Isobutyl methyl glyoxal; Acetyl isopentanoyl
M198	3-Methyl-2,4-nonanedione	3-Methylnonane-2,4-dione
M199	4-Methyl-2,6-dimethoxyphenol	2,6-Dimethoxy- <i>p</i> -cresol; 4-Methylsyringol; Phenol, 2,6-dimethoxy-4-methyl-
M200	3-Methyl-2-butanethiol	Isopentyl mercaptan; isoamyl mercaptan; Isopentanethiol; Isoamyl thioalcohol; Isoamyl sulfhydrylate; sec-Isoamylmercaptan
M201	3-Methyl-2-butanol	Isopropyl methyl carbinol; 2-Butanol, 3-methyl; Methyl isopropyl carbinol
M202	3-Methyl-2-buten-1-ol	Prenol
M203	2-Methyl-2-butenal	2-Methylcrotonaldehyde; 2-Methyl crotonaldehyde; tiglic aldehyde; 2,3-Dimethyl- acrolein; Tiglaldehyde
M204	3-Methyl-2-butenal	3-Methylcrotonaldehyde; 2-Butenal, 3-methyl-; 3-Methylcrotonaldehyde; Prenal; senecialdehyde; 3-Methyl but-2-enal
M205	trans-2-Methyl-2-butenic acid	2-Methyl-2-butenic acid; 2-Butenoic acid, 2-methyl-, (E); trans-2-Methyl-crotonic acid; tiglic acid; trans-2-

Order	General Name	Synonyms
		methylcrotonic acid
M206	3-Methyl-2-cyclohexen-1-one	3-Methyl- Δ^2 -cyclohexenone; 3-Methyl-d-2-cyclohexenone; 1-Methyl-1-cyclohexenone-3
M207	3-(5-Methyl-2-furyl) butanal	3-(5-Methyl-2-furyl) butyraldehyde; 2-Furanpropanal, β ,5-dimethyl-
M208	3-(5-Methyl-2-furyl)prop-2-enal	3-(5-Methylfuryl)acrolein; 1-(5-Methyl-2-furanyl)-1-propen-3-al; 3-(5-Methyl-2-furanyl)-2-propenal; 5-Methyl-2-furanacrolein; 2-Propenal, 3-(5-methyl-2-furanyl)-
M209	5-Methyl-2-hept-4-one	Fibertone; hazeltone; 2-hepten-4-one, 5-methyl
M210	2-(4-Methyl-2-hydroxyphenyl)propionic acid γ -lactone	dimethyl-3,6-benzo-2(3H)-furanone; furaminton
M211	2-Methyl-2-octenal	
M212	3-Methyl-2-oxobutanoic acid	3-Methyl-2-oxobutyric acid; 2-Oxoisovaleric acid; Dimethylpyruvic acid
M213	3-Methyl-2-oxobutanoic acid, sodium salt	Sodium 3-methyl-2-oxobutyrate, Sodium α -ketoisovalerate; Sodium 3-methyl-2-oxobutanoate
M214	3-Methyl-2-oxopentanoic acid	3-Methyl-2-oxovaleric acid, Methyl ethyl pyruvic acid; Sodium 3-methyl-2-oxopentanoic acid
M215	4-Methyl-2-oxopentanoic acid	4-Methyl-2-oxovaleric acid, Isopropyl pyruvic acid; 2-Keto-4-methyl-pentanoic acid; 4-Methyl-2-oxopentanoic acid; α -Ketoisocaproic acid
M216	3-Methyl-2-oxopentanoic acid, sodium salt	Sodium 3-methyl-2-oxobutyrate
M217	4-Methyl-2-oxopentanoic acid, sodium salt	Sodium 4-methyl-2-oxovalerate, 4-Methyl-2-oxovaleric acid, Sodium salt; Sodium 4-methyl-2-ketopentanoate; Sodium 4-methyl-2-oxopentanoate

Order	General Name	Synonyms
M218	4-Methyl-2-pentanone	Isobutyl methyl ketone; Isopropylacetone; Isohexanone; Butyl iso methyl ketone; hexone; Methyl isobutyl ketone; isohexanone-2
M219	2-Methyl-2-pentenal	α -Methyl- β -ethylacrolein; 3-Ethyl-2-methylacraldehyde 2-propylidene propionaldehyde; Methyl ethyl acrolein; 2,4-Dimethyl crotonaldehyde; Homotiglic aldehyde; Isohexenal
M220	4-Methyl-2-pentenal	
M221	2-Methyl-2-pentenoic acid	Strawberriff; 3-Ethyl-2-methylacrylic acid; β -Amylene- β -carboxylic acid; 2-Pentene-2-carboxylic acid; 2-Propylidenepropionic acid; 2-Pentene-2-carboxylic acid
M222	4-Methyl-2-pentyl-1,3-dioxolane	2-Amyl-4-methyl-1,3-dioxolane; 1,3-Dioxolane, 4-methyl-2-pentyl-, <i>cis</i> 4-Methyl-2-pentyl-1,3-dioxolane; Hexanal propylene glycol acetal
M223	5-Methyl-2-phenyl-2-hexenal	2-Phenyl-5-methyl-2-hexenal
M224	4-Methyl-2-phenyl-2-pentenal	Eglantal
M225	3-Methyl-2-phenylbutyraldehyde	α -iso-Propyl phenylacetaldehyde; α -Phenylisopentanal; α -Isopropyl phenylacetaldehyde; α -phenyl isovaleraldehyde; 3-Methyl-2-phenylbutanal; α -iso-propyl phenylacetaldehyde
M226	5-Methyl-2-thiophenecarboxyaldehyde	5-Methyl-2-thiophenecarbaldehyde; 5-Methyl-2-thenaldehyde; 5-Methyl-2- thiophenecarbaldehyde; 2-Formyl-5-methylthiophen; 2-Thiophene carboxaldehyde, 5-methyl; 2-Thiophenecarbaldehyde,5-methyl-
M227	2-Methyl-3-(2-furyl)acrolein	Furfurylidene-2-propanal; α -Methyl- β -furylacrolein; 2-Methyl-3-(2-furyl)propenal; 2-methyl-3-furylacrolein; α -Methylfurylacrolein; 2-propenal, 3-(2-furanyl)-2-methyl-; 3-(2- Furyl)-2-methylprop-2-enal; 2-Furfurylidenepropionaldehyde; α -Methyl- β - furylacrolein

Order	General Name	Synonyms
M228	5-Methyl-3(2H)-furanone	3(2H)-Furanone, 5-methyl-
M229	2-Methyl-3-(methylthio)furan	Dimethylthiofuran; 2-Methyl-3-thiomethylfuran
M230	2-Methyl-3-(p-methylphenyl)propanal	Satinaldehyde; 2-Methyl-3-(p-tolyl)propionaldehyde; 2-Methyl-3-(4-methylphenyl)-propanal; 2-Methyl-3-tolylpropionaldehyde
M231	2-Methyl-3,5 and 6-(furfurylthio)pyrazine	1. 2-Furfurylthio-3-methylpyrazine; 2. 2-furfurylthio-5-methylpyrazine; 3. 2-furfurylthio-6-methylpyrazine; 2-Furfuryl thio-(3,5 or 6)-methylpyrazine; Methyl(furfurylthio)pyrazine (mixture of isomers)
M232	2-Methyl-3,5 or 6-ethoxypyrazine	2-Methyl-3-ethoxypyrazine and 2-methyl-5-ethoxypyrazine and 2-methyl-6-ethoxypyrazine, 2-ethoxy-3 or 5 or 6-methylpyrazine
M233	6-Methyl-3,5-heptadien-2-one	2-Methyl-hepta-2,4-dien-6-one; methyl heptadienone; 1-Acetyl-4-methyl-1,3-pentadiene
M234	2-Methyl-3-buten-2-ol	
M235	2-Methyl-3-furanthiol	2-Methyl-3-furylmercaptan
M236	2-Methyl-3-furfurylthiopyrazine	

Order	General Name	Synonyms
M237	bis(2-Methyl-3-furyl) disulfide	3,3'-Dithio-bis-(2-methylfuran); 3,3'-Dithio-2,2'-dimethyldifuran; 2-Methyl-3-furyl disulfide
M238	bis(2-Methyl-3-furyl) tetrasulfide	3,3'-Tetrathio-bis(2-methylfuran); Bis(2-methyl-3-furyl) tetrasulfide; 2-Methyl-3-furyl tetrasulfide; 2-Methyl-3-furyl tetrasulphide
M239	(+/-)-3-[(2-Methyl-3-furyl)thio]-2-butanone	2-Butanone, 3-[(2-methyl-3-furanyl)thio]-; 3-[(2-Methyl-3-furyl)sulfanyl]-2-butanone; 3-[(2-Methyl-3-furanyl)sulfanyl]-2-butanone
M240	3-[(2-Methyl-3-furyl)thio]-4-heptanone	1,3-Diethylacetyl 2-methyl-3-furyl sulfide; 4-heptanone, 3-[(2-methyl-3-furanyl)]thiol-
M241	4-[(2-Methyl-3-furyl)thio]-5-nonanone	1,3-Dipropylacetyl 2-methyl-3-furyl sulfide; 5-nonanone, 4-((2-methyl-3-furyl)thio)-
M242	(E)-6-Methyl-3-hepten-2-one	trans-6-Methylhept-3-en-2-one; 3-Hepten-2-one, 6-methyl-
M243	5-Methyl-3-hexen-2-one	Isobutylidene acetone; 5- Methylhex-3-en-2-one
M244	Methyl-3-methyl-1-butenyl disulphide	
M245	1-Methyl-3-methoxy-4-isopropylbenzene	1-Isopropyl-2-methoxy-4-methylbenzene; 3-Methyl-p-cymene; Thymol methylether; 3-Methoxy-para-Cymene
M246	(E)-7-Methyl-3-octen-2-one	trans-7-Methyl-3-octen-2-one; 7- Methyl-3-octenone-2
M247	4-Methyl-3-penten-2-one	Isopropylidene acetone; Methyl isobutenyl ketone; Mesityl oxide
M248	2-Methyl-3-pentenoic acid	3-Pentenoic acid, 2-methyl-
M249	2-Methyl-3-tetrahydrofuranthiol	bis-(2-methyl-3-tetrahydrofuran)disulfide; 2- Methyltetrahydrofuran-3-thiol

Order	General Name	Synonyms
M250	2-Methyl-3-thioacetoxy-4,5-dihydrofuran	4,5-Dihydro-2-methyl-3-thioacetoxyfuran; 4,5-Dihydro-2-methyl-3-furanthiol acetate; ethanethioic acid, S-(4,5-dihydro-2-methyl-3-furanyl)ester; 2-Methyl-4,5-dihydro-3-furanthiol acetate; S-(4,5-dihydro-2-methyl-3-furyl thioacetate
M251	2-Methyl-3-tolylpropionaldehyde (mixed o,m,p-)	2-Methyl-3-tolyl propanal
M252	7-Methyl-4,4a,5,6-tetrahydro-2(3H)-naphthalenone	2(3H)-Naphthalenone, 4,4a,5,6-tetrahydro-7-methyl-
M253	2-Methyl-4-pentenoic acid	2-methylpent-4-enoate; 4-Pentenoic acid, 2-methyl-
M254	2-Methyl-4-phenyl-2-butanol	Butanol, 2-methyl-4-phenyl-; Dimethylphenylethyl carbinol; Dimethyl phenylethyl carbinol; 1,1-dimethyl-3-phenyl-1-propanol; α,α -Dimethyl- γ phenylpropyl alcohol; Phenyl ethyl dimethyl carbinol; Phenylethyl dimethyl carbinol
M255	2-Methyl-4-phenyl-2-butyl acetate	Dimethylphenylethyl carbonyl acetate
M256	2-Methyl-4-phenyl-2-butyl isobutyrate	Dimethylphenyl ethylcarbonyl isobutyrate
M257	3-Methyl-4-phenyl-3-buten-2-one	3-Benzylidene-2-butanone; 1-Methyl-1-benzylideneacetone; α -methyl- α - benzalacetone; Benzylidene methyl ethyl ketone; 3-Benzylidene-butane-2-one; Benzylidene methyl acetone; Benzylidene methyl acetone
M258	2-Methyl-4-phenylbutyraldehyde	2-Methyl-4-phenylbutanal; Butanol, 2-
M259	2-Methyl-4-propyl-1,3-oxathiane	1,3-Oxathiane, 2-methyl-4-propyl-; Oxane
M260	2-Methyl-5-(methylthio)furan	2-Methyl-5-thiomethylfuran; Methyl 5-methyl-2-furyl sulfide; (5- Methylfuryl-2)- thiomethane
M261	Methyl-5-hepten-2-ol	

Order	General Name	Synonyms
M262	6-Methyl-5-hepten-2-one	2-Methyl heptenone; 2-Methyl-2-hepten-6-one; methyl hexenyl ketone; Methyl heptenone
M263	6-Methyl-5-hepten-2-yl acetate	5-Hepten-2-ol, 6-methyl-, acetate; (+/-)-Sulcatol acetate
M264	5-Methyl-5-hexen-2-one	Methallyl acetone; 4-Acetyl-2-methyl-1-butene; Isobutylidene acetone; 2-Methylallylacetone; 2-Methyl-1-hexen-5-one; 2-Methyl-allylacetone
M265	2-Methyl-5-isopropylpyrazine	5-Isopropyl-2-methylpyrazine; 2-Isopropyl-5-methylpyrazine; 5-Methyl-5-isopropyl- 1,4-diazine
M266	2-Methyl-5-methoxythiazole	5-Methoxy-2-methylthiazole
M267	3-Methyl-5-propyl-2-cyclohexen-1-one	Celery ketone; 3-Methyl-5-propyl-2-cyclohexenone; 1-Methyl-5-n-propyl-1- cyclohexen-3-one
M268	4-Methyl-5-thiazole ethanol	4-Methyl-5-(β -hydroxyethyl)-thiazole; 5-Hydroxyethyl-4-methylthiazole; 5-(2-hydroxyethyl-4-methylthiazole); 2-(4-Methylthiazol-5-yl)ethanol; sulfuroil; 4-methyl-5-thiazolethanol; 5- β -Hydroxyethyl-4-methylthiazole; 4-Methyl-5-thiazole ethanol; 5-Thiazole ethanol, 4-methyl-
M269	4-Methyl-5-thiazoleethanol acetate	4-Methyl-5-(2-acetoxyethyl)-thiazole; Sulfuryl acetate; 4-Methyl-5-thiazolethanol acetate; 4-Methyl-5-thiazoleethyl acetate; 4-Methyl-5-thiazoleethanol acetate; 5-Thiazoleethanol, 4-methyl-, acetate
M270	(+/-)-2-(5-Methyl-5-vinyltetrahydrofuran-2-yl)propionaldehyde	2-Furanacetaldehyde, 5-ethenyltetrahydro- α ,5-dimethyl-, (+/-); Lilac aldehyde, (+/-)
M271	4-Methyl-5-vinylthiazole	Thiazole, 4-methyl-5-vinyl

Order	General Name	Synonyms
M272	5-Methyl-6,7-dihydro-5H-cyclopentapyrazine	5h-5-Methyl-6,7-dihydrocyclopenta(b) pyrazine; 6,7-Dihydro-5-methyl-5h- cyclopentapyrazine; Maple lactone pyrazine
M273	<i>p</i> -Methyl acetophenone*	<i>p</i> -Tolyl methyl ketone; 1-Acetyl-4-methylbenzene; <i>p</i> -Acetotoluene; <i>p</i> -methylacetophenone; 1-Methyl-4-acetyl benzene; Methyl <i>p</i> -tolyl ketone; 1-(4-Methylphenyl)ethane; <i>p</i> -Acetyl toluene
M274	2-Methylallyl butyrate	2-Methylallyl butanoate; Isopropenyl carbinyln-butyrate; Methanllyl butyrate; β -methylallyl-n-butyrate; 2-Methyl-2-propen-1-yl butyrate
M275	Methyl- α -ionone	Iraldein; α -Cetone; α -Cyclocitrylidene butanone; α -Cyclocitrylidene methyl ethyl ketone; α -n-methylionone; Raldeine; 5-(2,6,6-Trimethyl-2-cyclohexen-1-yl)-4- penten-3-one
M276	<i>o</i> -Methylanisole	1-Methoxy-2-methylbenzene; <i>o</i> -Cresyl methyl ether; 2-Methoxy toluene; <i>o</i> -methoxy toluene; Methyl <i>o</i> -tolyl ether
M277	<i>p</i> -Methylanisole	4-Methoxytoluene; <i>o</i> -Methyl- <i>p</i> -cresol; 1-Methoxy-4-methylbenzene; <i>p</i> -Cresyl methyl ether; <i>p</i> -Methoxy toluene; Methyl <i>p</i> -cresol; Methyl <i>p</i> -tolyl ether; Methyl <i>p</i> -tolyl ether
M278	α -Methylbenzyl acetate	<i>sec</i> -Phenylethyl acetate; α -Phenylethyl acetate; Styrollylacetat; 1-Phenethyl acetate; Gardenol; Methyl phenylcarbiny acetate; Styrallyl acetate; Styrolene acetate; 1-Phenylethyl acetate, Phenyl methyl carbiny acetate; Styrallyl acetate
M279	Methylbenzyl acetate (mixed <i>o,m,p</i>)	2-Methylbenzyl acetate; Tolyl acetate; Mixture of <i>o</i> -methylbenzyl acetate and <i>m</i> -methylbenzyl acetate and <i>p</i> -methylbenzyl acetate, Acetoxymethyl-toluene(<i>o,m,p</i>); Tolubenzyl acetate(<i>o,m,p</i>); Tolyl carbiny acetate(<i>o,m,p</i>); Tolyl acetate
M280	α -Methylbenzyl alcohol	1-Phenylethan-1-ol; 1-phenyl-1-hydroxyethane; Methylphenylcarbinol; 1-Phenylethanol; α -Phenylethyl alcohol; Phenyl methyl carinol; Styralyl alcohol; Styroly alcohol; Styrallyl alcohol

Order	General Name	Synonyms
M281	α -Methylbenzyl butyrate	1-Phenyl-1-ethyl butanoate; 1-Phenethyl butyrate; Methyl phenylcarbinyl-n-butyrate; styralyl butyrate; 1-Phenylethyl butyrate; Methyl phenyl carbinyl butyrate; α -Phenylethyl butyrate
M282	α -Methylbenzyl formate	α -Methylbenzyl methanoate; 1-Phenyl-1-ethyl formate; 1-Phenyl-1-ethyl methanoate; 1-Phenethyl formate; Methyl phenylcarbinyl formate; Styralyl formate; 1-Phenylethyl formate; α -Methylbenzyl formate
M283	α -Methylbenzyl isobutyrate	1-Phenyl-1-ethyl isobutyrate; α -Methylbenzyl 2-methylpropanoate; 1-Phenyl-1-ethyl 2-methylpropanoate; 1-Phenethyl isobutyrate; Methyl phenylcarbinyl isobutyrate; styralyl isobutyrate; 1-Phenylethyl 2-methylpropanoate, 1-Phenylethyl isobutyrate; α -phenethyl-2-methylpropanoate; α -Methylbenzyl isobutyrate; Methyl phenyl carbinyl butyrate
M284	α -Methylbenzyl propionate	1-Phenyl-1-ethyl propionate; 1-Phenethyl propionate; Methyl phenylcarbinyl propionate; styralyl propionate; 1-Phenylethyl propionate; α -Phenylethyl propionate
M285	Methyl- β - ionone	β -Iraldeine; β -Cetone; β -Cyclocitrylidene butanone; β -n-Methylionone; Raldeine; 5-(2,6,6-trimethyl-1-cyclohexen-1-yl)-4-penten-3-one; β -Methylionone
M286	α -Methyl- β -hydroxypropyl α -methyl- β -mercaptopropyl sulfide	2-Butanol, 3-[2-mercapto-1-methylpropyl]thio]-; 3-((2-Mercapto-1-methylpropyl)thio)- 2-butanol
M287	2-Methylbut-2-en-1-ol	

Order	General Name	Synonyms
M288	3-Methylbutanethiol	Isoamyl mercaptan; 3-Methy-1-butanethiol, Isoamyl mercaptan; 3- Methylbutane-1- thiol
M289	2-Methylbutyl 2-methylbutyrate	2-Methylbutyl 2-methylbutanoate; α,β -Methylbutyl-dl-2-methyl butanoate
M290	2-Methylbutyl 3-methylbutanoate	Methylbutyl 2-isovalerate; 2-Methylbutyl isopentanoate; d-sec-Butylcarbinyl isopentanoate; 2-Methylbutyl isovalerate; 2-Methylbutyl isovalerianate
M291	2-Methylbutyl acetate	2- Methylbutyl acetate
M292	2-Methylbutylamine	Butylamine, 2-methyl-; (+/-)-2-Methylbutylamine; β -Methylbutylamine; 1-Amino-2- methylbutane; 2-Ethylpropylamine; 2-Methyl-1-butanamine; 2-Methyl-1-butylamine; 2-Methylbutanamine; 2-Methylbutylamine; dl-2-Methylbutylamine
M293	2-Methylbutyraldehyde	2-methylbutanal; 2-Methylbutanal-1; α -Methyl butyraldehyde; methyl ethyl acetaldehyde
M294	3-Methylbutyraldehyde	Amyl iso aldehyde; Valeric iso aldehyde; Valeraldehyde(iso); Butanal, 3-methyl-; Isoamyl aldehyde; Isopentaldehyde, isovaleraldehyde; isovaleral; Isovaleric aldehyde; 3-Methylbutanal
M295	2-Methylbutyric acid	Butane-2-carboxylic acid; 2-Methylbutanoic acid; α -Methyl butyric acid; Methyl ethyl acetic acid; Optically active isovaleric acid
M296	α -Methylcinnamaldehyde	α -Methylcinnamal; α -methyl cinnamic aldehyde; 2-methyl-3-phenyl-2-propenal; 3-Phenyl-2-methyl acrolein; Methyl, α -cinnamaldehyde; 2- Methylcinnamaldehyde
M297	p-Methylcinnamaldehyde	3-p-Tolylpropenal; 3-(p-Methylphenyl)-propenal; 3-(4-methylphenyl)-2-propenal

Order	General Name	Synonyms
M298	6-Methylcoumarin	6-Methyl-2h-1-benzopyran-2-one; 6-Methyl-cis-o-coumarinic lactone; 5-Methyl-2- hydroxyphenylpropenoic acid lactone; Cocodescol; 6-Methylbenzopyrone; Pralina; Toncair; Toncarine; Tonkarin
M299	3-Methylcrotonic acid	Senecioic acid; 3,3-Dimethylacrylic acid; β,β -Dimethylacrylic acid; 3-Methyl-but- 2-enoic acid
M300	2-Methylcrotonic acid	Tiglic acid; 2-Methyl crotonic acid; 2-Methyl-2-butenic acid; trans-2,3-Dimethyl- acrylic acid
M301	2-Methylcyclohexanone	Methyl anone
M302	3-Methylcyclohexanone	Tetrahydro-m-cresol
M303	4-Methylcyclohexanone	
M304	Methylcyclopentenolone	3-Methyl-2-cyclopenten-2-ol-1-one; maple lactone; Cyclotene; 2-Hydroxy-3- methyl-2-cyclopenten-1-one; Kentonarome; 3-methylcyclopentan-1,2-dione; Methylcyclopentenolone; 3-Methylcyclopentane-1,2-dione; Corylone
M305	Methyl-delta-ionone	4-(2,6,6-Trimethyl-3-cyclohexen-1-yl)-3-methyl-3-buten-2-one; β -Iso methylionone; deta-methylionone; Isomethyl- β -ione; 5-(2,6,6-Trimethyl-3-cyclohexen-1-yl)- 4- penten-3-one
M306	(R)-5-(1-Methylethyl)-2-methyl-1,3-cyclohexadiene	
M307	(+/-)-1-2-Methylfuran	Ethanol, 1-ethoxy-, acetate; 1-Ethoxy-1-ethanol acetate; 1-Ethoxyethyl acetate

Order	General Name	Synonyms
M308	2-Methylfuran	α -Methylfuran; Silvan; Sylvan; Furan, 2-methyl-
M309	5-Methylfurfural	5-Methyl-2-furaldehyde; α -Methylfurfural
M310	(+/-)3-Methyl- γ -decalactone	2(3H)-Furanone; 5-hexyldihydro-4-methyl-(9CI), 5-Hexylihydro-4-methylfuran- 2(3H)-one
M311	2-Methylheptan-3-one	Butyl isopropyl ketone; 3-Heptanone; 2-Methylbutyl isopropyl ketone
M312	2-Methylheptanoic acid	Hexane-2-carboxylic acid; Isocaprolic acid; Isooctanoic acid; Methylamylacetic acid; 2-Methyloenanthic acid
M313	2-Methylhexanoic acid	2-Methylcaproic acid; 2-Butylpropionic acid; Butyl methylacetic acid; Hexane-2-carboxylic acid; 2-Butylpropanoic acid
M314	5-Methylhexanoic acid	Hexanoic acid, 5-methyl-; Isoheptanoic acid; Isovenanthic acid; Isoenanthic acid; Isoamyl acetic acid
M315	S- Methylmethioninesulphonium chloride	dl-(3-Amino-3-carboxypropyl)dimethyl sulfonium chloride; dl-Methylmethionine sulfonium chloride; S-Methylmethioninesulphonium chloride; Vitamin U; DL-(3-Amino-3-carboxypropyl)dimethylsulphonium chloride
M316	1-Methylnaphthalene	α -Methylnaphthalene
M317	4-Methylnonanoic acid	Isodecanoic acid; 4-Methylpelargonic acid; Nonanoic acid, 4-methyl-
M318	2-Methyloctanal	Methyl hexyl acetaldehyde
M319	4-Methyloctanoic acid	Isononanoic acid; Octanoic acid, 4-methyl-
M320	4-Methylpent-2-enoic acid	4-Methyl-2-pentenoic acid; 4-methylpent-2-en-1-oic acid

Order	General Name	Synonyms
M321	4-Methylpentan-2,3-dione	Methyl isopropyl diketone; Methyl propyl iso diketone; Propyl iso methyl diketone; Acetyl isobutyryl; 4-Methyl-2,3-pentanedione
M322	Methylpentanal	2-Methylpentanal; 2-Methyl valeraldehyde
M323	3-Methylpentanoic acid	2-Methylbutane-1-carboxylic acid; sec-Butylacetic acid; β -Methylvaleric acid; 3-Methylvaleric acid
M324	4-Methylpentanoic acid	Isocaproic acid; Isohexanoic acid; 3-Methylbutane-1-carboxylic acid; 4-Methylvaeric acid; pentanoic acid, 4-methyl-
M325	α -Methylphenethyl butyrate	1-Phenyl-2-propyl butyrate; 3-(p-Methylphenyl)-propenal; 1-Methyl-2-phenylethyl butyrate; Methyl benzyl carbiny butyrate
M326	2-Methylpiperidine	2-Pipecoline; (+/-)- α -Pipecoline; (+/-)-2-Methylpiperidine; α -Methylpiperidine; α -Pipecoline; DL-2-Methylpiperidine
M327	2-Methylpropyl 3-methylbutyrate	Isobutyl isovalerate; 2-Methylpropyl 3-methylbutanoate; Isobutyl isovalerate
M328	2-(1-Methylpropyl)thiazole	2-sec-Butyl thiazole; 2-But-2-ylthiazole; Thiazole, 2-sec-butyl-
M329	2-Methylpyrazine	2-Methyl-1,4-diazine; methylpyrazine
M330	6-Methylquinoline	p-Methylquinoline; p-toluquinoline; Cincholidine; Lepidine; Quinoline, 4-methyl-; Quinoline, 6-methyl
M331	5-Methylquinoxaline	5-Methyl-1,4-benzodiazine; Menoxaline
M332	Methylsulfinylmethane	Methyl sulfoxide; Dimethyl sulfoxide; Dimethyl-sulfoxide-
M333	2-Methyltetrahydrothiophen-3-one	2-Methyl-4,5-dihydro-3(2h)-thiophenone; 2-Methylthiolan-3-one; 4,5-Dihydro-2- methyl-3(2h)-thiophenone; 2-Methyl-4,5-dihydro-3(2h)thio-phenone; 4,5- Dihydro-2-methylthiophene-3(2H)-one; 2-Methyltetrathiophen-3-one; 2-Methyl-4,5-3-thiophenone; Dihydrothiophenone-3(2H), 2-methyl-
M334	2-Methyltetrahydrofuran-3-one	Dihydro-2-methyl-3(2h)-furanone; 4,5-Dihydro-2-methylfuran-3(2H)-one; Tetrahydro-2-methyl-3-oxofuran;

Order	General Name	Synonyms
		Dihydro-2-methyl-3-furanone; Dihydrofuranone- 3(2H)-, 2-methyl
M335	4-Methylthiazole	Thiazole, 4-methyl-
M336	Methylthio 2-(acetyloxy)propionate	Acetyl lactic acid thiomethyl ester; S-methyl-2-(acetyloxy) propanethioate; propanethioic acid, 2-(acetyloxy)-, S-methyl ester; Thiomethyl acetylacetate
M337	3-(Methylthio)-1-hexanol	3-Methylmercapto-1-hexanol
M338	1-(Methylthio)-2-butanone	2-Thia-4-hexanone
M339	4-(Methylthio)-2-butanone	3-Methylmercapto-2-butanone; Methyl propyl thioketone; 4-Methyl-2-butane-thione; 2-Pentane thione
M340	3-(Methylthio)-2-butanone	2-Butanone, 3-(methylthio)-; (+/-)-3-(Methylthio)butanone
M341	(3,5 or 6)-(Methylthio)-2-methylpyrazine	Mixture of 2-methyl-3-(methylthio)pyrazine and 2-methyl-5-(methylthio)pyrazine and 2-methyl-6-(methylthio)pyrazine, 2-Methyl-3,5-or 6-methylthiopyrazine; Methylpyrazinyl methyl sulfides (Mixture); (Methylthio)methylpyrazine(mixture of isomers); Pyrazine, methyl(methylthio); Methyl(methylthio)pyrazine (mixture of isomers)
M342	4-(Methylthio)-2-pentanone	2-Pentanone, 4-(methylthio)-
M343	4-(Methylthio)-4-methyl-2-pentanone	4-methyl-4-(methylthio)-2-pentanone

Order	General Name	Synonyms
M344	3-(Methylthio)butanal	3-(Methylthio)-butyraldehyde; 3-Methyl thio butyraldehyde; 3-Methyl propanethiol; Thio isoamyl aldehyde; Thio isovaleraldehyde
M345	4-(Methylthio)butanal	γ -(Methylmercapto) butyraldehyde; 4-(Methylthio) butyraldehyde; 4-(Methylmercapto)butanal, 4-(methylthio)butanal; γ -methylthiobutyraldehyde
M346	4-(Methylthio)butanol	4-(Methylthio)-1-butanol
M347	2-(Methylthio)ethanol	β -(Methylthio)ethanol; β -Hydroxyethyl methyl sulfide; β -Methylmercaptoethanol; 2-Hydroxyethyl methyl sulfide; 2-Methylmercaptoethanol; Hydroxyethyl methyl sulfide; Methyl 2-hydroxyethyl sulfide; S-Methylmercaptoethanol; 2-(Methylthio)ethan-1-ol
M348	(+/-)-3-(Methylthio)heptanal	
M349	3-(Methylthio)hexyl acetate	3-(Methylthio)-1-hexyl acetate
M350	3-(Methylthio)methylthiophene	3-Methylsulfanylmethylthiophene
M351	o-(Methylthio)phenol	2-(Methylthio)phenol; Thioguaiacol; 1-Hydroxy-2-methylmercaptobenzene; 2-Hydroxy-2-methylmercaptobenzene; 2-Methylmercapto phenol; Methyl-(2-hydroxyphenol)sulfide; 1-Thioguaiacol
M352	3-(Methylthio)propanol	3-(Methylthio)propan-1-ol; Methionol; 3-Methylthiol propyl alcohol; γ -Hydroxypropyl methyl sulfide; γ -Methyl mercaptopropyl alcohol; Methyl-3-hydroxypropyl sulfide; 3-Hydroxypropyl methyl sulfide; 3-(Methylthio)propylalcohol
M353	3-(Methylthio)propionaldehyde	Methylmercapto propionaldehyde; 3-Methylmercapto propionaldehyde; β -methylthio propionaldehyde; β -Methylmercapto propionaldehyde; Methional; β -methiopropionaldehyde; methyl- β -mercaptopropionaldehyde; 3-

Order	General Name	Synonyms
		Methylthiopropanol; 3-(Methylthio)propanal
M354	3-(Methylthio)propyl acetate	3-Acetoxypropyl methyl sulfide; Methionyl acetate; 1-Propanol, 3-(methylthio)-, acetate
M355	3-(Methylthio)propyl isothiocyanate	3-Methylmercatopropyl isothiocyanate; Isothiocyanic acid, 3-(Methylthio)propyl ester
M356	Methylthio-2-(propionyloxy)propionate	S-Methyl-2-(propionyloxy)propanethioate; Propionyl lactic acid thiomethyl ester; Thiomethyl propionylacetate
M357	1-Methylthio-2-propanone	(Methylthio)Acetone; α -(Methylthio)Acetone; α -(Methylthio)Propanone; 2-Thia-4-pentanone
M358	2-Methylthioacetaldehyde	Methylmercapto acetaldehyde; Methyl mercapto aldehyde
M359	3-Methylthiohexanal	3-Methylthiohexaldehyde
M360	Methylthiomethyl butyrate	
M361	Methylthiomethyl hexanoate	
M362	2-(Methylthiomethyl)-3-phenylpropenal	α -Benzylidene methional; 2-Propenal, 2-(methylthiomethyl)-3-phenyl-
M363	2-(Methylthiomethyl)butenal	2-Ethylidene methional; 2-(Methylthiomethyl)but-2-enal
M364	Methylthiomethylmercaptan	Methanethiol, 1-methylthio-; (Methylthio)methanethiol

Order	General Name	Synonyms
M365	12-Methyltridecanal	
M366	2-Methylundecanal	Methyl n-nonyl acetaldehyde; Aldehyde C-12, M.N.A.; 2-Methylhendecanal; methyl nonyl acetaldehyde; 2-methylundecanal
M367	2-Methylvaleric acid	2-Methylpentanoic acid; 2-Methylpentanoic-1-acid; methyl propyl acetic acid; α -Methyl valeric acid; Pentane-2-carboxylic acid
M368	Mintlactone	5,6,7,7a-Tetrahydro-3,6-dimethylbenzofuran-2(4H)-one; 2(4H)-Benzofuranone, 5,6,7,7a-tetrahydro-3,6-dimethyl-; dehydroxymenthofuro lactone; 3,6-Dimethyl- 5,6,7,7a-tetra-hydro-2(4H)-benzofuranone; 3,6-Dionethyl-4,5,6,7-tetra-hydro- 7aH-benzo(b) furan-2-one; Menthalactone
M369	L-Monomenthyl glutarate	Pentanedioic acid, mono[5 methyl-2-(1-methylethyl)cyclohexyl] ester[1L][1R(-)]Monomethyl glutarate
M370	Monomenthyl succinate	Butanedioic acid, monomethyl ester; Mono-Menth-3-yl succinate; Butanedioic acid, mono-(5-methyl-2-isopropyl-cyclohexyl)ester; 5-Methyl-2-(1-methylethyl_cyclohexyl butanedioate, mono ester; mono- Menth-3-yl succinate; Butanedioic acid, mono[5-methyl 2-(1-methyl-ethyl)cyclohexyl]ester, [1R-(1 α ,2 β ,5 α)]
M371	Myrcene	7-Methyl-3-methylene-1,6-octadiene
M372	Myristaldehyde	Aldehyde C-14; myristic aldehyde; Tetradecanal; <i>n</i> -Tetradecyl aldehyde; Tetradecyl aldehyde; Tetradecan-1-al
M373	Myrtenol	6,6-Dimethyl-2-oxomethylbicyclo [1.1.3]-hept-2-ene; 10-hydroxy-2-pinene; 2- pinen- 10-ol; 6,6-Dimethylbicyclo[3.1.1]hept-2-ene-methanol; 6,6-Dimethyl-2-oxomethylbicyclo [1,3,3]-hept-2-ene
M374	Myrtenyl acetate	(6,6-Dimethylbicyclo[3.3.1]hept-2-en-2-yl)methyl acetate; 2-Pinen-10-ol acetate

Order	General Name	Synonyms
M375	6,6-Myrtenyl formate	Myrtenyl formate; (6,6-Dimethylbicyclo[3.3.1]hept-2-en-2-yl)methyl formate; 2-Hydroxymethyl-6,6-dimethylbicyclo[3.1.1]hept-2-enyl formate; 2-Pinen-10-ol formate
M376	2-Methylpropan-2-ol	2-Propanol, 2-methyl-; tert-Butyl Alcohol; tert-Butanol; Trimethylcarbinol; Trimethylmethanol; 1,1-Dimethylethanol; 2-Methyl-2-propanol; tert-Butyl hydroxide; 2-Methylpropanol-2; t-Butyl alcohol; t-Butyl hydroxide; Methanol, trimethyl-; 2-Methyl n-propan-2-ol; Tert.-butyl alcohol; Methyl-2 propanol-2;t-Butanol;Ethanol, 1,1-dimethyl-
M377	3-Methylpentan-3-ol	3-Methyl-3-pentanol; Methyl-diaethylcarbinol; Methyl-diethylcarbinol; 3-Methyl-pentanol-(3); Methyl-3 pentanol-3;3-Pentanol, 3-methyl-
M378	p-Menthane-1,8-diol	Terpin; 1,8-Terpin; Dipenteneglycol; 4-(1-Hydroxy-1-methylethyl)-1-methylcyclohexanol;Cyclohexanemethanol, 4-hydroxy- $\alpha,\alpha,4$ -trimethyl-
M379	5-Methyl-2-(tert-butyl)phenol	m-Cresol, 6-tert-butyl-; 2-tert-Butyl-5-Methylphenol; 6-tert-Butyl-m-Cresol; 6-tert-Butyl-3-Methylphenol; 2-t-Butyl-5-methylphenol;Phenol, 2-(1,1-dimethylethyl)-5-methyl-;3-Methyl-6-tert-butylphenol
M380	2-Methylnaphthalene	β -Methylnaphthalene; Methyl-2-naphthalene;Naphthalene, 2-methyl-
M381	2-Methylquinoline	Khinaldin; Quinaldine; Chinaldine; 2-Methylchinolin; α -Methylquinoline;Quinoline, 2-methyl-
M382	2-Methyl-4,5-benzo-oxazole	2-Methyl-1,3-benzoxazole;Benzoxazole, 2-methyl-;2-Methylbenzoxazol
M383	Methyl 4-methylbenzoate	p-Toluic acid, methyl ester; p-Carbomethoxytoluene; Methyl p-methylbenzoate; Methyl p-toluate; Methyl 4-toluate; 4-Methylbenzoic acid, methyl ester; Methyl ester of 4-methylbenzoic acid; p-Toluylic acid, methyl ester;Methyl 4-toluate;Benzoic acid, 4-methyl-, methyl ester

Order	General Name	Synonyms
M384	Methyl acetoacetate	Acetoacetic acid, methyl ester; Methyl acetylacetate; Methyl 3-oxobutyrate; Acetoacetic methyl ester; Methyl acetylacetonate; Methylester kyseliny acetoctove; 3-Oxobutanoic acid methyl ester; Methyl 3-oxobutanoate; Butanoic acid, 3-oxo-, methyl ester
M385	Methyl formate	Formic acid, methyl ester; Methyl methanoate; Methylformiaat; Methyl ester of formic acid
M386	4-Methylpentan-2-ol	Isobutylmethylcarbinol; Isobutylmethylmethanol; Methylisobutylcarbinol; 2-Methyl-4-Pentanol; 4-Methyl-2-Pentanol; 1,3-Dimethylbutanol; Methyl amyl alcohol; 2-Methanol-4-pentanol; 4-Methylpentanol-2; 4-Pentanol, 2-methyl-; 4-Methyl-2-pentyl alcohol; 1,3-Dimethyl-1-butanol; Methyl-2-pentanol; Methylpentanol; Pentanol, 4-methyl-; Sec-hexyl alcohol; 2-Pentanol, 4-methyl-
M387	3-Methylpyridine	3-Picoline; β -Methylpyridine; β -Picoline; m-Picoline; meta-Methylpyridine; B-Picoline; 5-Methylpyridine; Pyridine, 3-methyl-
M388	Methyl decanoate	Capric acid methyl ester; Methyl caprate; Methyl caprinate; Methyl-n-caprate; Methyl n-decanoate; n-Capric acid methyl ester; Decanoic acid, methyl ester
M389	Methyl hexadecanoate	Palmitic acid, methyl ester; n-Hexadecanoic acid methyl ester; Methyl n-hexadecanoate; Methyl palmitate; Hexadecanoic acid, methyl ester
M390	Methyl octadecanoate	Stearic acid, methyl ester; n-Octadecanoic acid, methyl ester; Methyl n-octadecanoate; Methyl stearate; Methyl ester of octadecanoic acid; Methyl (Z)-9-octadecenoate; Octadecanoic acid, methyl ester
M391	Methyl oleate	Oleic acid, methyl ester; Methyl cis-9-octadecenoate; (Z)-9-Octadecenoic acid methyl ester; cis-9-Octyldecenoic acid, methyl ester; Emery; Emery, oleic acid ester; Methyl 9-octadecenoate; Methyl cis-9-octadecanoate; Methyl cis-9-octadecenoate; oleic acid methyl ester; Methyl (9Z)-9-octadecenoate; 9-octadecenoic acid, methyl ester (Z); Methyl-cis-oleate; Methyl (Z)-9-oleate; Methyl cis-9-octadecanoate; Methyl cis-9-octadecenoate, oleic acid

Order	General Name	Synonyms
		methyl ester; cis-9-Octadecenoic acid, methyl ester; 9-Octadecenoic acid (Z)-, methyl ester
M392	2-Methyl-4,5-benzothiazole	2-Methyl-1,3-benzothiazole; Benzothiazole, 2-methyl-; 2-Methylbenzothiazole
M393	Malonic acid	Propanedioic acid; Carboxyacetic acid; Dicarboxymethane; Methanedicarboxylic acid; Kyselina malonova; Methanedicarbonic acid
M394	3-Methoxyphenol	Phenol, 3-methoxy-; m-Guaiacol; Phenol, m-methoxy-; m-Hydroxyanisole; m-Methoxyphenol; Resorcinol methyl ether; Resorcinol monomethyl ether; 1-Hydroxy-3-methoxybenzene; 3-Hydroxyanisole
M395	4-Methoxyphenol	Phenol, 4-methoxy-; Phenol, p-methoxy-; p-Guaiacol; p-Hydroxyanisole; p-Methoxyphenol; Hydroquinone methyl ether; Hydroquinone monomethyl ether; 1-Hydroxy-4-methoxybenzene; 4-Hydroxyanisole; Monomethyl ether hydroquinone; Hydroxyanisole; Mequinol
M396	4-Methylquinoline	Lepidine; γ -Methylquinoline; p-Methylquinoline; Cincholepidine; Lepidin; 4-Lepidine; Quinoline, 4-methyl-
M397	p-Menthan-8-ol	Dihydro- α -terpineol; 1-Methyl-4-isopropylcyclohexane-8-ol; 2-(4-Methylcyclohexyl)-2-propanol; α -Dihydroterpineol; Cyclohexanemethanol, $\alpha, \alpha, 4$ -trimethyl-
M398	4-Methylpent-3-enoic acid	Pyroterebic acid; 3-Pentenoic acid, 4-methyl-; 4-Methyl-3-pentenoic acid
M399	Myrtanol	Bicyclo[3.1.1]heptane-2-methanol, 6,6-dimethyl-; (6,6-Dimethylbicyclo[3.1.1]hept-2-yl)methanol

Order	General Name	Synonyms
M400	5-Methylheptan-3-one	Ethyl 2-methylbutyl ketone; 3-Methyl-5-heptanone; 5-Methyl-3-heptanone; 5-Methylheptanone-(3); Ethyl sec-amyl ketone;3-Heptanone, 5-methyl-
M401	Myrcenol	2-Methyl-6-methylene-7-octen-2-ol; 3-Methylene-7-methyl-1-octen-7-ol;7-Octen-2-ol, 2-methyl-6-methylene-
M402	2-Methylthiophene	2-methylthiacyclopentadiene;Thiophene, 2-methyl-
M403	Methyl isothiocyanate	Isothiocyanic acid, methyl ester; Isothiocyanatomethane; Methyl mustard oil; Methyl thioisocyanate;Methyl-isothiocyanat;Methane isothiocyanate;Methane, isothiocyanato-
M404	3-Methylbutan-2-one	Isopropyl methyl ketone; Ketone, isopropyl methyl; Methyl butanone-2; Methyl isopropyl ketone; Methylbutanone; 3-Methyl-2-butanone; 2-Acetylpropane;2-Butanone, 3-methyl-
M405	3-Methylpentan-2-ol	3-Methyl-2-pentanol; 3-Methyl-4-pentanol;2-Pentanol, 3-methyl-
M406	3-Methylpentan-2-one	sec-Butyl Methyl ketone; Methyl sec-butyl ketone; Methyl 1-methylpropyl ketone; 3-Methyl-2-pentanone;2- Pentanone, 3-methyl-
M407	2-Methylacetophenone	Acetophenone, 2'-methyl-; o-Acetyltoluene; o-Methylacetophenone; 2-Acetyltoluene; 1-(2- Methylphenyl)ethanone;2'-Methylacetophenone; 2'-Methylacetylphenone;Ethanone, 1-(2-methylphenyl)-
M408	2-Methylpentan-2-ol	2-Pentanol, 2-methyl-; 2-Hydroxy-2-methylpentane; 1,1-Dimethylbutanol; 2-Methyl-2-hydroxypentane; Methyl-2 pentanol-2;2-Methyl-2-pentanol
M409	3-Methoxybenzaldehyde	m-Anisaldehyde; m-Methoxybenzaldehyde; 3-Anisaldehyde; Metamethoxybenzaldehyde;Benzaldehyde, 3- methoxy-
M410	Methyl 2-oxopropionate	Pyruvic acid, methyl ester; Methyl pyruvate; Methylglyoxylic acid methyl ester;Propanoic acid, 2-oxo-, methyl ester;Methyl 2-oxopropanoate

Order	General Name	Synonyms
M411	3-Methylthiophene	3-Thiolenene; Methyl-3-thiophene; Thiophene, 3-methyl-
M412	2-Methylhexan-3-ol	1-Isopropyl-1-butanol; 2-Methyl-3-hexanol; 5-Methyl-4-hexanol; 3-Hexanol, 2-methyl-
M413	Methyl crotonate	Crotonic acid, methyl ester, (E)-; trans-2-Butenoic Acid methyl ester; Methyl trans-crotonate; Methyl trans-2-butenolate; (E)-2-Butenoic acid methyl ester; Methyl α -crotonate; Methyl E-crotonate; Methyl (2E)-2-butenolate; Methyl 2-butenolate, (E)-; methyl (E)-2-butenolate; (E)-Crotonic acid methyl ester; 2-Butenoic acid, methyl ester, (E)-
M414	6-Methylheptan-3-one	Ethyl isoamyl ketone; 2-Methyl-5-heptanone; 6-Methyl-3-heptanone; 3-Heptanone, 6-methyl-
M415	4-Methylpentan-1-ol	Isohexyl alcohol; Isohexanol; 2-Methyl-5-pentanol; 4-Methyl-1-pentanol; 4-methylpentanol; Pentanol, 4-methyl-; 1-Pentanol, 4-methyl-
M416	Methyl butyl sulfide	Sulfide, butyl methyl; Butyl methyl sulfide; Butyl methyl thioether; 2-Thiahexane; 1-(Methylthio)butane; Butyl methyl sulphide; Methyl-n-butyl sulfide; n-Butyl methyl sulfide; 1-(Methylsulfanyl)butane; Butane, 1-(methylthio)-
M417	3-(Methylthio)propionic acid	Propanoic acid, 3-(methylthio)-; Propionic acid, 3-(methylthio)-; 4-Thiapentanoic acid; 3-(Methylsulfanyl)propanoic acid; 3-(Methylthio)propionic acid
M418	3-Methylbut-3-en-1-ol	Isobutenylcarbinol; Isopropenylethyl alcohol; 2-Methyl-1-buten-4-ol; 3-Isopentenyl alcohol; 3-Methyl-3-buten-1-ol; Methallyl carbinol; 3-methyl-3-butenol; Methyl-3-but-3-en-1-ol; 3-Buten-1-ol, 3-methyl-
M419	Methyl 4-pentenoate	methyl pentenoate
M420	2-Methyloctan-1-ol	1-Octanol, 2-methyl-; 2-Methyl-1-octanol

Order	General Name	Synonyms
M421	2-Methylhexanal	2-Methylhexanaldehyde;Hexanal, 2-methyl-
M422	6-Methylheptan-2-one	2-Methyl-6-heptanone; 6-Methyl-2-heptanone; Methyl isohexyl ketone;2-Heptanone, 6-methyl-
M423	Myrcenyl acetate	
M424	Methyl deca-4,8-dienoate	
M425	1-Methyl-1H-pyrrole-2-carboxaldehyde	2-Formyl-1-methylpyrrole; N-Methyl-2-formylpyrrole; 1-Methyl-2-formylpyrrole; N-Methylpyrrole-2-carboxaldehyde; 1-Methylpyrrole-2-carboxaldehyde; Pyrrole-2-carboxaldehyde, 1-methyl-; N-Methylpyrrole-2-aldehyde; 1-Methyl-1H-pyrrole-2-carbaldehyde; 1-Methyl-2-pyrrolaldehyde; 1-methyl-2-pyrrolecarboxaldehyde; 1-methylformylpyrrole; 1-Methylpyrrole-2-carbaldehyde; N-methylpyrrole-2-carboxy aldehyde;1-methylpyrrole-2-carboxyaldehyde;1H-Pyrrole-2-carboxaldehyde, 1-methyl-
M426	p-Mentha-1,3-dien-7-al	
M427	Methyl 4-methoxybenzyl ether	
M428	4-Methylhexanoic acid	
M429	8-p-menthene-1,2-diol	limonenediol;8,9-p-Menthen-1,2-diol; 8-p-Menthene-1,2-diol; d-Limonene-1,2-diol; Limonene glycol
M430	Menthyl formate	
M431	Methyl geranate	2,6-Octadienoic acid, 3,7-dimethyl-, methyl ester; Methyl (2E)-3,7-dimethyl-2,6-octadienoate;Methyl geraniate
M432	2-Methylbutyl propionate	1-Butanol, 2-methyl-, propanoate; 1-Butanol, 2-methyl-, propionate;1-Butanol, 2-methyl-, propanoate

Order	General Name	Synonyms
M433	2-Methylbutyl isobutyrate	Propanoic acid, 2-methyl-, 2-methylbutyl ester; Isobutyric acid, 2-methylbutyl ester; 2-Methylbutyl 2-methylpropanoate; 2-Methylbutyl Isobutyrate
M434	Methyl dec-2-enoate	Methyl ester of 2-Decenoic acid; Methyl (2E)-2-decenoate; 2-Decenoic acid, methyl ester; Methyl 2-decenoate
M435	2-Methylbutyl hexanoate	Hexanoic acid, 2-methylbutyl ester; 2-Methylbutyl caproate
M436	Methyl methanethiosulfonate	S-Methyl methanethiosulphonate; S-Methyl methanethiosulfonate; Methanesulfonylthioic acid, S-methyl ester; Methanesulfonic acid, thio-, S-methyl ester; Methyl methanesulfonylthioate; S-Methyl methanesulfonylthioate; dimethyl thiosulfonate; S-methyl methylthiosulfonate; Methyl methanethiosulfonate
M437	1,1-Diethoxy-2-methylbutane	Butyraldehyde, 2-methyl-, diethyl acetal; Butane, 1,1-diethoxy-2-methyl-
M438	3-Methylhexanoic acid	
M439	Methyl propyl sulfide	Sulfide, methyl propyl; 2-Thiapentane; 1-(Methylthio)propane; 1-(Methylsulfanyl)propane; Propane, 1-(methylthio)-
M440	Methyl vanillate	Vanillic acid, methyl ester; Methyl 3-methoxy-4-hydroxybenzoate; Methyl 4-hydroxy-3-methoxybenzoate; 4-Hydroxy-3-methoxybenzoic acid methyl ester; Methyl ester of 4-hydroxy-3-methoxybenzoic acid; 4-Hydroxy-3-methoxybenzoic acid methyl ester; Vanillic acid methyl; Benzoic acid, 4-hydroxy-3-methoxy-, methyl ester
M441	4-Methyl-2-propyl-1,3-dioxolane	1,3-Dioxolane, 4-methyl-2-propyl
M442	4-methylthiobutyl isothiocyanate	1-isothiocyanato-4-(methylthio)-butane; methyl thio butyl isothiocyanate
M443	6-(methylthio)hexyl isothiocyanate	

Order	General Name	Synonyms
M444	5-(methylthio)pentyl isothiocyanate	
M445	2-Methylbut-3-en-1-ol	2-Methyl-3-buten-1-ol; 2-methyl-3-butene-1-ol;3-Buten-1-ol, 2-methyl-
M446	Methyl hexyl ether	Ether, hexyl methyl; Hexyl methyl ether; 1-Methoxyhexane;Hexane, 1-methoxy-
M447	2-(Methylthio) Ethyl Acetate	
M448	Methyl isoprenyl sulfide	
M449	Menthyl hexanoate	
M450	Methyl dodec-2-enoate	
M451	2-(4-Methyl-5-thiazolyl)ethyl formate	sulfuryl formate;Methanoic acid, 2-(4-methyl-5-thiazolyl)ethyl ester
M452	Methyl tiglate(Methyl 2-methylcrotonate)	Tiglic acid methyl ester; 2-Butenoic acid, 2-methyl-, methyl ester, (E)-; Crotonic acid, 2-methyl-, methyl ester, (E)-; Methyl (E)-2-methylcrotonate; Methyl trans-2-methyl-2-butenoate; 2-Carbomethoxy-2-butene, (E)-; Methyl α -methylcrotonate; Methyl trans-2-methylcrotonate; Methyl (2E)-2-methyl-2-butenoate; 2-Methylcrotonic acid (Tiglicacid), methyl ester; methyl (E)-2-methyl-2-butenoate
M453	Methyl dec-4-enoate	
M454	Methyl prop-1-enyl sulfide	
M455	α -Muurolene	
M456	2-Methyl-1,1-di-isopentyloxypropane	
M457	Megastigma-4,6,8-trien-3-one	

Order	General Name	Synonyms
M458	3-Methyl-1,1-di-isopentyloxybutane	
M459	1-(2-Methylbutoxy)-1-isopentyloxyethane	
M460	3-Methylhexanal	Hexanal, 3-methyl-
M461	Methyl 3-acetoxyhexanoate	Hexanoic acid, 3-(acetyloxy)-,methyl ester
M462	2,8-p-menthadien-1-ol	cis-p-Mentha-2,8-dien- dien-1-ol; p-Mentha-2,
M463	2-Methoxy-3-propylpyrazine	
M464	Menthyl phenylacetate	
M465	3-Mercapto-2-methylpropionic acid	
M466	Myrtanyl acetate	(6,6-Dimethylbicyclo[3.1.1]hept-2-yl)methyl acetate;Bicyclo[3.1.1]heptane-2-methanol, 6,6-dimethyl-, acetate
M467	1-Mercapto-p-menthan-3-one	mercapto menthanone
M468	Mixture of methyl cyclohexadiene and methylene cyclohexene	Cyclohexene, 3-methylene-; 1-Methylene-2-cyclohexene; 3-Methylene-1-cyclohexene;1-Methyl-1,3-cyclohexadiene
M469	6-Methyloctanal	
M470	8-(Methylthio)-p-menthan-3-one	
M471	Methyl prop-1-enyl trisulfide	
M472	3-Methylnonano-1,4-lactone	
M473	2-Methylbutyl formate	1-Butanol, 2-methyl-, formate

Order	General Name	Synonyms
M474	3-Mercapto-3-methyl-1-butyl acetate	3-Mercapto-3-methylbutyl acetate; 3-Methyl-3-sulfanylbutyl acetate;
M475	2-Methylbutyl butyrate	Butanoic acid, 2-methylbutyl ester; 2-methylbutyl butanoate
M476	3-Methyl-3-buten-1-yl hexanoate	3-Methylbut-3-en-1-yl hexanoate
M477	3-Methyl-3-buten-1-yl butyrate	
M478	2-Methylbutyl dodecanoate	
M479	2-Methylbutyl decanoate	
M480	p-Menthan-8-yl acetate	
M481	l-Menthyl acetoacetate	Butanoic acid, 3-oxo-, 5-methyl-2-(1-methylethyl)cyclohexyl ester, [1R-(1 α ,2 β ,5 α)]-DSL; Butanoic acid, 3-oxo-, 5-methyl-2-(1-methylethyl)cyclohexyl ester, [1R-(1 α ,2 β ,5 α)]- (AICS); (-)-Menthyl acetoacetate
M482	6-Methylene-2,10,10-trimethyl-1-oxaspiro[4.5]dec-7-ene	Vitispirane;2,10,10-trimethyl-6-methylene-1-oxaspiro[4.5]dec-7-ene
M483	1-(Methylthio)pentan-3-one	1-(Methylthio)-3-pentanone; 3-Pentanone, 1-(methylthio)-; 1-(Methylsulfanyl)-3-pentanone
M484	2-Methylbutyl octanoate	2-Methylbutyl caprylate
M485	Megastigma-5,8-dien-4-one	
M486	Methyl heptenone propylene glycol acetal	
M487	S-(Methylthiomethyl) 2-methylpropanethioate	
M488	Methyl propyl tetrasulfide	
M489	3-Mercapto-1-butyl acetate	3-Mercaptobutyl acetate

Order	General Name	Synonyms
M490	2-(3-Methyl-1,3-butadienyl)-4-methyltetrahydrofuran	
M491	2-Methylbutyl tetradecanoate	
M492	2-(4-Methyl-5-thiazolyl)ethyl propionate	sulfuryl propionate;Propanoic acid, 2-(4-methyl-5-thiazolyl)ethyl ester (9CI)
M493	2-(4-Methyl-5-thiazolyl)ethyl butanoate	sulfuryl butyrate
M494	Sulfuryl hexanoate	2-(4-Methyl-5-thiazolyl)ethyl hexanoate
M495	(+/-)-cis- and trans-2-methyl-2-(4-methyl-3-pentenyl) cyclopropanecarbaldehyde	2-methyl-2-(4-methylpent-3-enyl)cyclopropane-1-carbaldehyde
M496	2-Methylbutyl 3-methyl-2-butenate (2-Methylbutyl 3-methylbutenoate)	2-Methylbutyl senecioate
M497	Sulfuryl decanoate	2-(4-Methyl-5-thiazolyl)ethyl decanoate
M498	(+/-)-Menthyl 3-hydroxybutyrate	Menthyl methyl lactate; Butanoic acid, 3-hydroxy-, 5-methyl-2-(1-methylethyl)cyclohexyl ester
M499	2-(4-Methyl-5-thiazolyl)ethyl octanoate	Octanoic acid, 2-(4-methyl-5-thiazolyl)ethyl ester (6CI)
M500	5-Methylhexyl acetate	methyl hexyl acetate
M501	2-(5-Methyl-4-thiazolyl)ethyl isobutyrate	sulfuryl isobutyrate ;Propanoic acid, 2-methyl-, 2-(5-methyl-4-thiazolyl)ethyl ester (9CI)
M502	2-Methyl-3-furyl methylthiomethyl disulfide	2-methyl[[(methylsulfanyl)methyl] disulfanyl]furan
M503	3-Mercaptoheptyl acetate	Aruscolate
M504	4-Methylpentyl isovalerate	methyl pentyl isovalerate

Order	General Name	Synonyms
M505	Myristic acid	Tetradecanoic acid; Crocid
M506	(R)-N-(1-Methoxy-4-methylpentan-2-yl)-3,4-dimethylbenzamide	Benzamide,N-[(1R)-1-(methoxymethyl)-3-methylbutyl]-3,4-dimethyl-; N-[(2R)-1-Methoxy-4-methyl-2-pentanyl]-3,4-dimethylbenzamide
M507	3-Methyl-5-(2,2,3-trimethylcyclopent-3-en-1-yl)pent-4-en-2-ol	Ebanol; 4-Penten-2-ol, 3-methyl-5-(2,2,3-trimethyl-3-cyclopenten-1-yl)-
M508	3-(3,4-Methylenedioxyphenyl)-2-methylpropanal	2-Methyl-3-(3,4-methylenedioxyphenyl)propanal; alpha-Methyl-3,4-(methylenedioxy)hydrocinnamaldehyde; 2-Methyl-3-(3,4-methylenedioxyphenyl)propionaldehyde; alpha-Methyl-1,3-benzodioxole-5-propionaldehyde; 1,3-Benzodioxole-5-propanal, alpha.-methyl-
M509	d-8-p-Menthene-1,2-epoxide	D-1,2-Epoxyimonene; D-Limonene 1,2-epoxide; (4R)-1-Methyl-4-(prop-1-en-2-yl)-7-oxabicyclo[4.1.0]heptane
M510	2-Mercaptoheptan-4-ol	2-Sulfanylheptan-4-ol; 2-Thioheptan-4-ol; 2-Mercapto-4-heptanol
M511	3-Mercaptohexanal	Hexanal, 3-mercapto-
M512	4-Mercapto-3-methyl-2-butanol	4-Thio-3-methyl-2-butanol; 3-Methyl-4-sulfanyl-2- butanol; 3-Methyl-4-sulfanyl-butan-2-ol
M513	3-Mercapto-1-pentanol	
M514	3-Mercaptopropionic acid	2-Mercaptoethanecarboxylic acid; Thiohydracrylic acid; 3-Thiopropionic acid; 3-Thiopropionic acid; Propanoic acid, 3-mercapto-; 3-mercaptopropanoic acid
M515	L-Methionylglycine	{[(2S)-2-Amino-4-(methylsulfanyl)butanoyl]amino}acetic acid
M516	(±)-6-Methoxy-2,6-dimethylheptanal	6-Methoxy-2,6-dimethylheptanal
M517	2-(4-Methoxyphenoxy)propionic acid	
M518	(1R,2S,5R)-N-(4-Methoxyphenyl)-5-methyl-2-(1-methylethyl)cyclohexanecarboxamide	(1R,2S,5R)-Methoxyphenyl)-5-methyl-2-propan-N-(4-2-ylcyclohexane-1-carboxamide; N-(4-Methoxyphenyl)-p-menthane-carboxamide; (1R,2S,5R)-N-(4-Methoxyphenyl)-5-methyl-2-(propan-2-yl)cyclohexanecarboxamide
M519	2-Methoxy-6-(2-propenyl)phenol	o-Eugenol; 2-Allyl-6-methoxyphenol
M520	2-Methoxypyridine	
M521	4-Methylbenzaldehyde propyleneglycol acetal	1,3-Dioxolane, 4-methyl-2-p-tolyl-; 1,3-Dioxolane, 4-methyl-2-(4-methylphenyl)-

Order	General Name	Synonyms
M522	4-Methylbenzyl alcohol	p-Tolylcarbinol; p-Tolualcohol; 4-(Hydroxymethyl)toluene; 4-Methylbenzenemethanol; (4-Methylphenyl)methanol
M523	N-(2-Methylcyclohexyl)-2,3,4,5,6-pentafluorobenzamide	PFMC benzamide; 2,3,4,5,6-Pentafluoro-N-(2-methylcyclohexyl)benzenecarboximide acid
M524	8-Methyldecanal	
M525	1-Methyldithio-2-propanone	Methyl 2-oxopropyl disulfide; 1-(Methyldithio)-2-propanone; 1-Methyl disulfanyl acetone; 1-(Methyldithio)-2-propanone; 1-(Methyl disulfanyl)propan-2-one
M526	Methyl 3-(furfurylthio)propionate	Methyl furfuryl mercaptopropionate; Methyl 3-[(furan-2-ylmethyl)sulfanyl]propanoate
M527	6-Methylheptanal	Isocetan-1-al
M528	8-Methylnonanal	Isodecanal
M529	Methyl octyl sulfide	Methyl(octyl)sulfane; 2-Thiadecane; 1-Methylthiooctane; 1-Methylsulfanyloctane
M530	4-Methylpentyl-4-methylvalerate	4-Methylpentyl 4-methylpentanoate; Pentanoic acid, 4-methyl-, 4-methylpentyl ester; 4-Methylpentanoic acid, 4-methylpentyl ester
M531	2-(4-Methylphenoxy)-N-(1H-pyrazol-3-yl)-N-(thiophen-2-ylmethyl)acetamide	N-(1H-Pyrazol-5-yl)-N-(thiophen-2-ylmethyl)-2-(p-tolyloxy)acetamide
M532	Methyl beta-phenylglycidate	(±)-Methyl 2,3-epoxycinnamate; Methyl 3-phenyl oxirane-2-carboxylate; Methyl 3-phenyloxirane-2-carboxylate; 3-Phenyl glycidic acid methyl ester; Methyl 3-phenyloxirane-2-carboxylate
M533	trans,trans/cis,trans-2,6,8-N-(2-Methylpropyl)-2,6,8-decatrienamide	2E,6Z,8E-Decatrienoic acid N-isobutylamide; N-Isobutyldeca-trans-2,cis-6,trans-8-trienamide; (2E,6Z,8E)-N-(2-Methylpropyl)-2,6,8-decatrienamide; Spilanthol; (1Z,2E/6Z,8E)-N-(2-Methylpropyl)deca-2,6,8-trienimide acid
M534	4-Methyl-2-propyl-1,3-oxathiane	2-Propyl-4-methyl-1,3-oxathiane
M535	(+/-)-2-Methyltetrahydrofuran-3-thiol acetate	2-Methyl tetrahydrofuran-3-thioacetate; 2-Methyl-3-thioacetoxymethyl tetrahydrofuran; (?)-(2-Methyltetrahydrofuran-3-yl) ethanethioate
M536	3-(Methylthio)-decanal	3-(Methylsulfanyl)decanal
M537	3-(Methylthio)propylamine	S-Methylhomocysteamine; 1-Amino-3-(methylthio)propane; 3-(Methylmercapto)propylamine; 3-Aminopropyl methyl sulfide; 3-(Methylsulfanyl)propylamine; 3-(Methylthio)propan-1-amine

Order	General Name	Synonyms
M538	3-(Methylthio)propyl hexanoate	Hexanoic acid, 3-(methylthio)propyl ester; Methionyl hexanoate
M539	(1-Methyl-2-(1,2,2-trimethylbicyclo[3.1.0] hex-3-ylmethyl)cyclopropyl) methanol	Cyclopropanemethanol, 1-methyl-2-[(1,2,2-trimethylbicyclo[3.1.0]hex-3-yl)methyl]-
N001	2-Naphthalenethiol	2-Naphthyl mercaptan; 2-mercaptanaphthalene; 2-Thionaphthol; β -Thionaphthol
N002	β -Naphthyl anthranilate	2-Naphthyl anthranilate; 2-Naphthalenol, 2-aminobenzoyl ester; 2-Naphthyl o-aminobenzoate
N003	β -Naphthyl ethyl ether	Nerolin; Bromelia; 2-Ethoxynaphthalene; Ethyl-2-naphthyl ther; Ethyl- β -naphthyl ether; Nerolin II; Nerolin bromelia
N004	β -Naphthyl methyl ether	
N005	β -Naphthyl isobutyl ether	Isobutyl β -naphthyl ether; Fragarol; 2-isobutoxynaphthalene; Isobutyl β -naphthyl ether; Naphthalene, 2-(2-methylpropoxy)-; Nerolin fragarol
N006	Neohesperidine dihydrochalcone	Neohesperidin DHC
N007	Nerol	Nerosol; Allerol; cis-2,6-Dimethyl-2,6-octadien-8-ol; Nergenol; Nerodol; Nerolo; Neraniol; cis-3,7-Dimethyl-2,6-octadien-1-ol Note: see Geraniol for trans-form; Nerolol
N008	Nerol oxide	3,6-Dihydro-4-methyl-2(2-methylpropen-1-yl)-2H-pyran; 3,6-Dihydro-4-methyl-2- (2-methyl-1-propenyl)-2H-pyran
N009	Nerolidol	Peruvicol; methylvinyl homogeryl carbinol; Melaleucol; Dodecatriene; 3,7,11- Trimethyl-1,6,10-dodecatrien-3-ol
N010	Neryl acetate	cis-3,7-Dimethyl-2,6-octadien-1-yl ethanoate; Neryl ethanoate; cis-3,7-Dimethyl-2,6- octadien-1-yl acetate
N011	Neryl butyrate	cis-3,7-Dimethyl-2,6-octadien-1-yl butanoate; cis-3,7-Dimethyl-2,6-octadien-1-yl butyrate; Neryl-n-butyrate
N012	Neryl formate	cis-3,7-Dimethyl-2,6-octadien-1-yl methanoate; cis-3,7-Dimethyl-2,6-octadien-1-yl formate; Meryl methanoate
N013	Neryl isobutyrate	cis-3,7-Dimethyl-2,6-octadien-1-yl 2-methylpropanoate; cis-3,7-Dimethyl-2,6- octadien-1-yl isobutyrate; neryl 2-methylpropanoate; 2-cis-3,7-Dimethyl-2,6-octadien- 1-yl isobutyrate
N014	Neryl isovalerate	Neryl isovalerianate; Neryl 3-methylbutanoate; cis-3,7-Dimethyl-2,6-octadien-1-yl butanoate; 3-Methylbutanoate; cis-3,7-Dimethyl-2,6-octadien-1-yl isopentanoate; cis-3,7-Dimethyl-2,6-octadien-1-yl

Order	General Name	Synonyms
		isovalerate; Neryl- β -methylbutyrate; cis-3,7-Dimethyl-2,6-octadien-1-yl-2-methylbutanoate; Neryl 3-methylbutyrate
N015	Neryl propionate	Neryl propanoate; cis-3,7-Dimethyl-2,6-octadien-1-yl propionate; cis-3,7-Dimethyl-2,6-octadien-1-yl propanoate
N016	Non-2-enal	3-Hexyl-2-propenal; 3-Hexylacrolein; Heptylideneacetaldehyde; β -Hexylacrolein; α -Nonyl aldehyde; Nonylenic aldehyde; trans-2-Nonenal
N017	Nona-2,4,6-trienal	
N018	Nona-2-trans-6-cis-dienal	2,6-Nonadienal; Cucumber aldehyde; Nona-2,6-dienal; 2,6-nonadienal(trans, cis)
N019	2,6-Nonadien-1-ol	2,4-Nonadienal; Nonadienol; Cucumber alcohol; Violet leaf alcohol; tr-2, cis-6- Nonadien-1-ol
N020	(E,Z)-3,6-Nonadien-1-ol	(E)-3-(Z)-nonadien-1-ol; trans-3-cis-6-nonadienal
N021	(Z,Z)-3,6-Nonadien-1-ol	Nona-3,6-dien-1-ol; cis-3, cis-6-nonadienol
N022	2,4-Nonadien-1-ol	
N023	(E,Z)-2,6-Nonadien-1-ol acetate	trans-2-cis-6-Nonadien-1-yl acetate
N024	(E,Z)-3,6-Nonadien-1-ol-acetate	trans-3-cis-6-Nonadien-1-yl acetate
N025	2,4-Nonadienal	trans,trans-2,4-nonadien-1-al; trans-2- Nonenal; 3-Hexyl-2-propenal; Non-2-enal; 3 or β -hexyl acrolein; Heptyliceneacetaldehyde; tr-2, tr-4-Nonadienal
N026	2-trans, 6-trans-Nonadienal	Nona-2(trans),6(trans)-dienal; 2,6-Nonadienal, (E,E)-; (E,E)-nona-2,6-dienal
N027	2,6-Nonadienal diethyl acetal	1,1-Diethoxy-2,6-nonadiene; 1,1- Diethoxynona-2,6-diene; Nonadienyl diethyl acetal

Order	General Name	Synonyms
N028	γ -Nonalactone*	4-nonanolide; 5-pentylidihydro-2(3H)-furanonenona-1,4-lactone; aldehyde c-18; 4-n-Amyl-4-hydroxybutyric acid lactone; γ -pelargolactone; γ -Nonyllactone; Nonano-1,4-lactone; γ -Amyl butyrolactone; Coconut aldehyde; 4-Hydroxynonanoic acid, γ -lactone; nonanolide; γ -Lactone; Nonanolide-1,4; γ -Nonalactone
N029	(+/-)Nonan-3-yl acetate	3-Nonanol, acetate; 1-Ethylhept-1-yl acetate; 1-Ethylheptyl acetate, Non-3-yl acetate
N030	Nonanal	Pelargonaldehyde; Nonoic aldehyde; Nonyl-aldehyde; Aldehyde C-9; Nonanoic aldehyde; n-Nonyl aldehyde; α -Oxononane; Pelargonic aldehyde; n-Nonanal
N031	1,3-Nonanediol acetate (mixed esters)	Nonane diacetate; Jasmon acetate; Octyl crotonate, Mixture of 3-acetate and 1-(2-hydroxyethyl)heptyl acetate; Hexylene glycol diacetate; 3-hexy-1,3-propane-diol acetate, mixed esters; Nonanediol-1,3-acetate; Octylcrotonyl acetate; Diacetate; diasmol; Diasmylacetate; Drago-jasimia; jasmelia; jasmonyl; Jersemal; Hexylene glycol acetate; 1,3-Nonanediol acetate; Acetoxy nonyl acetate(mixed esters)
N032	Nonanediol diacetate	
N033	1,4-Nonanediol diacetate	1,4-Nonadiol diacetate; Nonane-1,4-diyl diacetate; Nonanediol-1,4 acetate
N034	1,9-Nonanedithiol	1,9-Dimercaptononane; nonamethylene dimercaptan
N035	Nonanoic acid	Nonoic acid; <i>n</i> -nonylic acid; Octane-1-carboxylic acid; Pelargonic acid; Nonylic acid; Nonoic
N036	2-Nonanol	n-heptyl methyl carbinol; Methyl n-butyl carbinol; Methyl-n-Heptyl carbinol; sec-n-Nonanol; Methyl heptyl carbinol

Order	General Name	Synonyms
N037	3-Nonanon-1-yl acetate	1-hydroxy-3-nonanone acetate; Ketone alcohol ester; Methylol methyl hexyl ketone acetate; 3-Oxononanyl acetate
N038	2-Nonanone	Hethyl methyl ketone; Nonan-2-one; Methyl heptyl ketone; 3-Oxononyl acetate
N039	3-Nonanone	Ethyl hexyl ketone; 3-Oxononanone
N040	cis-6-Nonen-1-ol	<i>cis</i> -6-Nonenol; 6-Nonen-1-ol, (Z)-; Non-6-en-1-ol
N041	cis-2-Nonen-1-ol	(Z)-2-nonen-1-ol; 2-Nonen-1-ol,(Z)-; Non-2(cis)-en-1-ol
N042	3-Nonen-2-one	Methyl heptenyl ketone
N043	cis-6-Nonenal	Non-6(cis)-enal; 6-Nonenal, (Z)-; cis-6-Nonen-1-al; Non-6-enal
N044	2-Nonenoic acid	(E)-2-Nonenoic acid; trans-2-Nonenoic acid
N045	2-Nonenoic acid γ -lactone	5-Pentyl-5H-furan-2-one; 2(5H)-Furanone, 5-pentyl-; 2-Nonenoic acid, 4-hydroxy-, γ -lactone
N046	trans-2-Nonenol	Non-2(trans)-en-1-ol; trans-2-nonen-1-ol
N047	Nonyl acetate	Acetate C-9; Nonanol acetate; <i>n</i> -Nonyl acetate; Pelargonyl acetate; Nonyl ethanoate
N048	Nonyl alcohol	Nonanol; Alcohol C-9; Nonanol-1; 1-nonanol; Octyl carbinol; Pelargonic alcohol; Nonan-1-ol; n-Nonyl alcohol
N049	Nonyl isovalerate	Nonyl isovalerianate; Nonyl 3-methylbutanoate; Nonanol isopentanoate; n-nonyl 3-methylbutanoate; Nonyl isopentanoate

Order	General Name	Synonyms
N050	Nonyl octanoate	Nonyl caprylate; n-Nonyl octoate; Nonyl octylate
N051	Nootkatone	4a,5-Dimethyl-1,2,3,4,4a,5,6,7-octahydro-7-keto-3-isopropenyl-naphthalen; 4,4a,5,6,7,8- Hexahydro-6-isopropenyl-4,4a-dimethyl-2(3H)-naphthalenone; 4a,5-Dimethyl- 1,2,3,4,4a,5,6,7-keto-3-isopropenyl-naphthalene; 5,6-Dimethyl-8-isopropenyl-bicyclo- (4,4,0)-dec-1-en-3-one
N052	Nonanedioic acid	1,7-Heptanedicarboxylic acid; Heptanedicarboxylic acid; Azelainic acid; Azelaic acid, technical grade; 1,9-Nonanedioic acid; 1,7-Dicarboxyheptan;n-Nonanedioic acid
N053	(E)-4-Nonenal	4-Nonenal, (4E); (E)-Non-4-enal; trans-4-nonenal;
N054	8-Nonen-2-one	Non-8-en-2-one
N055	cis-3-Nonen-1-ol	(3Z)-3-Nonen-1-ol; (Z)-3-nonen-1-ol;3-Nonen-1-ol, (Z)-
N056	Non-3-enyl acetate	
N057	Nonanal dimethyl acetal	Nonane, 1,1-dimethoxy-; n-Nonanal dimethyl acetal; 1,1-Dimethoxynonane
N058	1-Nonen-3-ol	Hexylvinylcarbinol; 1-Vinylheptanol; Non-1-en-3-ol; nonene-1-ol-3;1-Nonene-3-ol
N059	5-Nonen-(E)-2-one	(5E)-5-Nonen-2-one
N060	Non-2-en-4-one	2-Nonen-4-one;(2E)-2-Nonen-4-one;Nonenone
N061	2,4-Nonadiene	(2E,4E)-2,4-Nonadiene; (E,E) - 2,4-nonadiene;trans-2,trans-4-nonadiene

Order	General Name	Synonyms
N062	Nonanal propyleneglycol acetal	2-Octyl-4-methyl-1,3-dioxolane
N063	Non-6-enyl acetate	6-Nonen-1-ol, acetate, (z)-;(Z)-6 Nonen-1-yl acetate; (Z)-6-nonenyl acetate; (Z)-non-6-en-1-yl acetate;(6Z)-6-Nonenyl acetate
N064	2-Nonanone propyleneglycol acetal	2-heptyl-2,4-dimethyl-1,3-dioxolane
N065	E-6-Nonenal	trans-6-Nonenal
N066	(±)-Naringenin	(±)-5,7-Dihydroxy-2-(4-hydroxyphenyl)-4H-chroman-4-one
N067	Naringin dihydrochalcone	Glucopyranoside,3,5-dihydroxy-4-(p-hydroxyhydrocinnamoyl)phenyl2-O-(6-deoxy-alpha-L-mannopyranosyl)-,beta-D-; 1-[4-[[2-O-(6-Deoxy-alpha-L-mannopyranosyl)-beta-D-glucopyranosyl]oxy]-2,6-dihydroxyphenyl]-3-(4-hydroxyphenyl)-1-propanone
N068	1-Nonen-3-one	
O001	Ocimene	3,7-Dimethyl-1,3,6-octatriene; trans-b-Ocimene
O002	8-Ocimenyl acetate	2,6-Dimethyl-2,5,7-octatriene-1-yl acetate; Piperitanate
O003	9-Octadecenal	Olealdehyde; Elialdehyde; Octadecenyl aldehyde; Oleic Aldehyde
O004	Octadien-1-ol	(E,E)-2,4-Octadien-1-ol; trans-2,4-Octadienol; trans,trans-2,4-Octadien-1-ol
O005	(E,E)-3,5-Octadien-2-one	Octa-3,5-dien-2-one trans, trans-3,5-Octadien-2-one; trans,trans-3,5-octadien-2-one

Order	General Name	Synonyms
O006	2-trans-6-trans-Octadienal	2,6-Octadienal; Octa-2(trans),6(trans)-dienal; 2,6-Octadienal,(E,E)-; trans,trans-2,6- octadienal
O007	trans,trans-2,4-Octadienal	Octa-2(trans),4(trans)-dienal; 2,4-Octadienal; (E,E)-2,4-octadienal
O008	Octahydrocoumarin	2H-1-Benzopyran-2-one, octahydro-; Bicyclononalactone; Cyclohexyl lactone; Octahydro-2H-1-benzopyran-2-one
O009	γ-Octalactone	4-Octanolide; 5-Butyldihydro-2(3H)-furanone; Octa-1,4-lactone; 4-n-Butyl-4- hydroxybutyric acid lactone; Octano-1,4-lactone; γ-n-Butyl-γ-butyrolactone; 4-Hydroxyoctanoic acid, γ-lactone; n-octalactone; octanolide-1,4
O010	delta-Octalactone	5-Octanolide; 6-propyltetrahydro-2-pyrone; 5-Hydroxyoctanoic acid lactone; Octa-1,5-lactone; 5-Hydroxyoctanoic acid lactone; δ-Propyl-δ-valerolactone; 5-Propyl-5-hydroxypentanoic acid lactone; Octano-1,5-lactone; Tetrahydro-6-propyl- 5-hydroxy-2H-pyran-2-one; octanoic acid, Δ-lactone; delta-Octalactone
O011	Octan-3-yl formate	(+/-)Octan-3-yl formate; 3-Octanol, formate; Oct-3-yl formate; 1-Ethylhex-1-yl formate; (+/-)-Octan-3-yl formate
O012	Octanal*	Aldehyde C-8; Caprylaldehyde; Caprylic aldehyde; n-Octaldehyde; n-Octylaldehyde; n-Octanal; Octyl aldehyde
O013	Octanal dimethyl acetal	Aldehyde C-8 dimethyl acetal; caprylaldehyde dimethyl acetal; 1,1-Dimethoxy octane; octaldehyde dimethyl acetal; C-8 dimethylacetal; Octanal dimethyl acetal; Caprylaldehyde dimethyl acetal
O014	2,3-Octanedione	Octan-2,3-dione
O015	1,8-Octanedithiol	1,8-Dimercaptooctane; Octamethylene dimercaptan
O016	Octanoic acid	Caprylic acid; C-8- acid; Octoic acid; C-8; Octylic acid; 1-Heptanecarboxilic acid
O017	1-Octanol	Alcohol C-8; n-Caprylic alcohol; Heptyl carbinol; Octyl alcohol; Capryl alcohol; pri-octyl alcohol; n-Octyl alcohol; Caprylic alcohol; pri.-Octyl alcohol

Order	General Name	Synonyms
O018	2-Octanol	Octyl alcohol, secondary; Capryl alcohol, secondary; sec-Caprylic alcohol; sec-Capryl alcohol; Methyl hexyl carbinol; Hexyl methyl carbinol; sec-n-Octyl alcohol; Octan-2-ol; sec-octhyl alcohol
O019	3-Octanol	Amyl ethyl carbinol; Ethyl <i>n</i> -amyl carbinol; <i>d</i> - <i>n</i> -Octanol; Amylethylcarbinol
O020	2-Octanone	Hexyl methyl ketone; n-Hexyl methyl ketone; methyl hexyl ketone; Octan-2-one
O021	3-Octanone	Amyl ethyl ketone; Ethyl amyl ketone; Ethyl- <i>n</i> -amyl ketone
O022	cis-3-Octen-1-ol	<i>cis</i> -3-Octenol; 3-octen-1-ol, (Z)-; Oct-3-en-1-ol
O023	cis-5-Octen-1-ol	Z-5-octen-1-ol; Oct-5(cis)-en-1-ol
O024	(E)-2-Octen-1-ol	Oct-2-en-1-ol; trans-2-Octen-1-ol
O025	2-Octen-1-yl acetate	Oct-2-enyl acetate; 2-Octen-1-ol, acetate, (E)-
O026	3-Octen-2-ol	Methyl hexenyl carbinol; trans-3-Octen-2-ol
O027	3-Octen-2-one	Methyl hexenyl ketone; Oct-3-en-2-one
O028	1-Octen-3-ol	Amyl vinyl carbinol; Matsutake alcohol; 3-octenol; n-Pentyl vinyl carbinol; Oct-1-en-3-ol; Amylvinylcarbinol; Matsuka alcohol; Matsutakeol; Pentyl vinyl carbinol
O029	1-Octen-3-one	Amyl vinyl ketone; Vinyl amyl ketone
O030	1-Octen-3-yl acetate	Pentyl crotonyl acetate; Amyl vinyl carbinol acetate; 3-Acetoxy octene; Amyl crotonyl acetate; Amyl vinyl carbonyl acetate; Octenyl acetate; β -octenyl acetate; n-pentyl vinyl carvinyl acetate; Matsutake acetate; Oct-1-en-3-yl acetate; Amyl crotonyl acetate

Order	General Name	Synonyms
O031	1-Octen-3-yl butyrate	Butanoic acid, 1-ethenylhexyl ester; Oct-1-en-3-yl butyrate
O032	(E)-2-Octen-4-ol	Oct-2-en-4-ol; trans-2-octenol-4; Butyl propenyl carbinol; 2-Octen-4-ol; trans-2-octen-4-ol
O033	2-Octen-4-one	Butylpropenyl ketone; Propenyl butyl ketone ; Butyl propenyl ketone
O034	2-Octenal	2-Pentyl acrolein; α -Amyl acrolein
O035	cis-5-Octenal	Oct-5(cis)-enal; 5-Octenal, (Z)-; (Z)-5-Octenal
O036	2-Octenoic acid	(E)-2-Octanoic acid; trans-2-octenoic acid
O037	trans-2-Octenyl butyrate	trans-2-Octen-1-yl butanoate; trans-2-Octen-1-yl butyrate; Oct-2(trans)-enyl butyrate; trans-2-Octenyl butyrate
O038	(Z)-5-Octenyl propionate	(Z)-5-octen-1-yl propanoate; (Z)-5-octen-1-yl propionate; cis-5-Octen-1-yl propionate
O039	cis-3-Octenyl propionate	Pearlate; 3-Octen-1-ol, propanoate, (Z)-
O040	(E)-2-(2-Octenyl)cyclopentanone	2-Hexylidene cyclopentanone and 2-hexyl-2-cyclopenten-1-one (mixture); 2-Hexyl-2-cyclopenten-1-one and 2-hexylidenecyclopentanone (mixture); 2-Hexylcyclopent-2-en-1-one and 2-hexylidenecyclopentanone, Dihydrojasmane; n-Hexylidene cyclopentanone; 2-(2-octenyl)cyclopentanone
O041	Octyl 2-furoate	2-Furancarboxylic acid, octyl ester. Octyl 2-furancarboxylate; 2-Furoic acid
O042	Octyl 2-methylbutyrate	Butanoic acid, 2-methyl-, octyl ester; Octyl-2-methylbutanoate
O043	Octyl acetate	Octyl ethanoate; Acetate C-8; Capryl acetate; n-octyl acetate; 2-Ethyl hexyl acetate

Order	General Name	Synonyms
O044	3-Octyl acetate	n-Amyl ethyl carbinyl acetate; 1-Ethyl hexyl acetate
O045	Octyl butyrate	Octyl butanoate; Octyl-n-butyrate; 3-octyl butyrate
O046	Octyl formate	n-Octyl formate; Octyl formate; octyl methanoate
O047	Octyl heptanoate	Octyl heptoate; Octyl heptylate; Heptanoic acid, octyl ester; Octyl oenanthate
O048	Octyl isobutyrate	Octyl 2-methylpropanoate
O049	Octyl isovalerate	Octyl isovalerianate; Octyl isopentanoate; Octyl 3-methylbutyrate; n-Octyl-3- methylbutyrate; Octyl 3- methylbutanoate
O050	Octyl octanoate	Octyl caprylate; <i>n</i> -Octyl octoate; Octyl octylate
O051	Octyl phenylacetate	n-Octyl phenylacetate; Octyl-n-toluate; n-Octyl- α -toluate; Octyl α -toluate
O052	Octyl propionate	Octyl propanoate
O053	2-Oxo-3-phenyl propionic acid	3-Phenylpyruvic acid; 3-Phenyl-2-oxopropanoic acid
O054	3-Oxobutanal dimethyl acetal	4,4-Dimethoxy-2-butanone, Acetaldehyde dimethylacetal; 3-Ketobutyraldehyde dimethyl acetal; Acetyl acetaldehyde, dimethyl acetal; 1,1-Dimethyl-oxy-3-butanone; 4,4- Dimethoxybutan-2-one
O055	2-Oxobutyric acid	Butanoic acid, 2-oxo-; α -Ketobutyric acid; Ketobutyric acid
O056	3-Oxodecanoic acid glyceride	Glyceryl ester of 3-oxodecanoic acid; 2,3-Dihydroxypropyl 3-oxodecanoate; Glyceryl β -ketodecanoate; Glyceryl monoester of 3-oxodecanoic acid
O057	3-Oxododecanoic acid glyceride	Glyceryl ester of 3-oxododecanoic acid; 2,3-Dihydroxypropyl 3-oxododecanoate; Glyceryl β -ketododecanoate; Glyceryl monoester of 3-oxododecanoic acid

Order	General Name	Synonyms
O058	3-Oxohexadecanoic acid glyceride	Glyceryl ester of 3-oxohexadecanoic acid; 2,3-Dihydroxypropyl 3-oxohexadecanoate; Glyceryl β -ketohehexadecanoate; Glyceryl monoester of 3-oxohexadecanoic acid
O059	3-Oxohexanoic acid glyceride	Glyceryl ester of 3-oxohexanoic acid; 2,3-Dihydroxypropyl 3-oxohexanoate; Glyceryl β -ketohehexanoate; Glyceryl diester of 3-oxohexanoic acid
O060	3-Oxooctanoic acid glyceride	Glyceryl ester of 3-oxooctanoic acid; 2,3-Dihydroxypropyl 3-oxooctanoate; Glyceryl β -ketoheoctanoate; Glyceryl monoester of 3-oxooctanoic acid
O061	2-Oxopentanedioic acid	2-Oxoglutaric acid; 2-Ketoglutaric acid; α -Ketoglutaric acid; 2-Oxo-1,5-pentanedioic acid
O062	3-Oxotetradecanoic acid glyceride	Glyceryl ester of 3-oxotetradecanoic acid; 2,3-Dihydroxypropyl 3-oxotetradecanoate; Glyceryl β -ketotetradecanoate; Glyceryl monoester of 3-oxotetradecanoic acid
O063	1-Octene	α -Octene; α -Octylene; n-1-Octene; Caprylene; Oct-1-ene; OCTENE-1; Neodene 8; Octylene
O064	Octadecan-1-ol	n-Octadecanol; n-Octadecyl alcohol; n-1-Octadecanol; Octadecyl alcohol; Stearol; Stearyl alcohol; Stenol; Steraffine; Decyl octyl alcohol; 1-Hydroxyoctadecane; Octadecanol; Octanodecanol; 1-Octadecanol
O065	cis-9-Octadecenol	9-Octadecen-1-ol, (Z)-; cis-9-Octadecen-1-ol; cis-9-Octadecenyl Alcohol; (Z)-9-Octadecen-1-ol; Octadec-9-en-1-ol; Octadec-9Z-enol; (9Z)-9-Octadecen-1-ol; Oleic alcohol; Octadec-9-en-1-ol; Oleyl Alcohol
O066	Oleyl acetate	
O067	2-Octylthiophene	2-n-Octylthiophene; Thiophene, 2-octyl-
O068	3-octenoic acid	octenoic acid
O069	Octyl hexanoate	Hexanoic acid, Octyl ester; n-Octyl hexanoate
O070	4,5-Octanedione (Octane-4,5-dione)	n-Octane-4,5-dione; Bibutyryl; 4,5-Octadione

Order	General Name	Synonyms
O071	Ocimenol	2,6-Dimethyl-5,7-octadien-2-ol; (5E)-2,6-Dimethyl-5,7-octadien-2-ol;5,7-Octadien-2-ol, 2,6-dimethyl-
O072	4-Octen-3-one	Oct-4-en-3-one; (4E)-4-Octen-3-one
O073	trans-4-Octenoic acid	
O074	Octane-1,3-diol	Propane-1,3-diol, 1-pentyl-;1,3-Octanediol
O075	cis-5-Octenoic acid	octenoic acid
O076	cis-4-Octenol	octenol
O077	Octanal diethyl acetal	1,1-Diethoxyoctane;n-Octanal diethyl acetal;Octane, 1,1-diethoxy-
O078	1,5-Octadien-3-one	Octa-1,5-dien-3-one;octadien
O079	Octa-3,5-dien-1-ol	
O080	Octanal propylene glycol acetal	
O081	Octa-1,5-dien-3-ol	
O082	Oleic acid	Oleinic acid; trans-Elaidic acid; (Z)-Octadeca-9-enoic acid

Order	General Name	Synonyms
O083	1,5-Octadien-3-ol	Octa-1,5-dien-3-ol; Octa-1,5-dien-3-ol, (E)-isomer
O084	Octahydro-4,8a-dimethyl-4a(2H)-naphthol	Geosmin; Octahydro-4,8a-dimethyl-4a(2H)-naphthol; 4,8a-Dimethyloctahydronaphthalen-4a(2H)-ol; 4a(2H)-Naphthalenol, octahydro-4,8a-dimethyl-1,10-Dimethyl-9-decalol
O085	(R)-(-)-1-Octen-3-ol	(R)-Oct-1-en-3-ol
O086	cis-5-Octenyl acetate	(5Z)-Octen-1-ol acetate; (Z)-5-Octenyl acetate; cis-5-Octenyl acetate; (5Z)-Oct-5-en-1-yl acetate
O087	2-Octyl-2-dodecenal	
O088	(±)-6-Octyltetrahydro-2H-pyran-2-one	5-Tridecanolide; 6-Octyltetrahydro-2H-pyran-2-one; Tetrahydro-6-octyl-2H-pyran-2-one; delta-Tridecalactone; 5-Hydroxytridecanoic acid delta lactone; delta-Octylvalerolactone; Trideca-1,5-lactone
P001	Paraldehyde	s-Trioxane; 2,4,6-Trimethyl-1,3,5-trioxane; Acetaldehyde, trimer; Elaldehyde; paracetaldehyde; 2,4,6-Trimethyl-1,3,5-trioxacyclohexane
P002	Pent-2-enyl hexanoate	2-Penten-1-yl hexanoate
P003	omega-Pentadecalactone	Angelicalactone; Exaltolide; 15-Hydroxypentadecanoic acid; w-Lactonel pentadecanolide; Thibetolide; 15-Pentadecanolide; Oxacyclohexadecan-2-one; Pentadeca-1,5-lactone; Cyclopentadecanolide; Pentadecanolide; Muscolactone; 14-Oxytetradecane carbonic acid lactone; Pentadecano-1,15-lactone; Pentalide; omega-Pentadecalactone; 15-Hydroxytetradecanoic acid lactone; 1,15-Epoxy-pentadecan-1-one
P004	2-Pentadecanone	Methyl tridecyl ketone; Pentadecan-2-one; 2-Oxopentadecane
P005	2,4-Pentadienal	
P006	2,3-Pentadione	β,γ-Dioxopentane; Pentan-2,3-dione; Acetyl propionyl; 2,3-Pentanedione
P007	2-Pentanethiol	sec-Amylmercaptan; 2-Mercaptopentane; 1-Methylbutanethiol; 2-Pentyl mercaptan

Order	General Name	Synonyms
P008	2-Pentanol	Propyl methyl carbinol; α -Methylbutanol; sec-amyl Alcohol; Methyl n-propyl carbinol; sec-n-Amyl alcohol
P009	2-Pentanone	Propyl methyl ketone; Ethyl acetone; Methyl propyl ketone; Pentane-2-one
P010	2-Pentanoylfuran	1-(2-Furanyl)-1-pentanone; Butyl 2-furyl ketone; 1-Pentanone, 1-(2-furanyl)-; 1-Pentanone, 1-(2-furyl)-
P011	3-Penten-2-one	Ethylidene acetone; methyl propenyl ketone
P012	1-Penten-3-ol	Vinyl ethyl carbinol; Ethyl vinyl carbinol; Pent-1-en-3-ol; B-Pentenol
P013	1-Penten-3-one	Ethyl vinyl ketone; propionyl ethylene
P014	2-Penten-3-one	2-Pentylpyridine; 2-Amylpyridine
P015	2-Pentenal	3-Ethyl-2-propenal; 3-Ethylacrolein; 2-Ethylacrylic aldehyde
P016	4-Pentenoic acid	Pent-4-enoic acid; Allyl acetate; allyl acetic acid
P017	2-Pentenoic acid	Pent-2-enoic acid; Pent-2-en-1-oic acid
P018	4-Pentenyl acetate	4-Penten-1-ol, acetate; 4-Penten-1-yl acetate; 5-Acetoxy-1-pentene; 1-Acetoxy-4- Pentene
P019	Pentyl 2-furyl ketone	2-Furyl pentyl ketone; 2-Hexanoylfuran; 1-(2-furyl-1-hexanone)
P020	2-Pentyl acetate	1-Methylbutyl acetate, 2-Pentanol acetate
P021	2-Pentyl butyrate	1-Methylbutyl butyrate; 2-pentyl butanoate; Pent-2-yl butyrate
P022	2-Pentyl-1-buten-3-one	3-Methylene-2-octanone; 2-Octanoic acid, 3-methylene-
P023	Pentylamine	Pentylamine; 1-Aminopentane; 1-Pentylamine; Amylamine; Monoamylamine; Monopentylamine; n-Amylamine; n-Pentylamine; Norleucamine

Order	General Name	Synonyms
P024	2-Pentylfuran	2-Amylfuran
P025	α -Phellandrene	p-Mentha-1,5-diene; 1-methyl-4-propyl-iso-1,5-cyclohexadiene; Dihydro-p-cymene; 5-propyl-iso-2-methyl-1,3-cyclohexadiene; 4-Propyl-iso-1-methyl-1,5-cyclohexadiene; 1-Proypl-iso-4-methyl-2,4-cyc;Ohexadiene; 1-Isopropyl-4-methyl-2,4-cyclohexadiene; 4-Isopropyl-1-methyl-1,5-cyclohexadiene; 5-Isopropyl-2-methyl-1,3-cyclohexadiene; 1-Methyl-4-isopropyl-1,5-cyclohexadiene; 2-Methyl-5-isopropyl-1,3-cyclohexadiene; ; Phellandrene
P026	Phenethyl 2-furoate	2-Furancarboxylic acid; 2-phenethyl ester; 2-Phenethyl 2-furoate
P027	Phenethyl 2-methylbutyrate	β -Phenethyl α -methylbutanoate; Benzylcarbiny 2-methylbutyrate; 2-Phenylethyl 2-methylbutanoate; Anatoly; Benzyl carbiny ethyl methyl acetate; phenethyl- α - methylbutanoate
P028	Phenethyl acetate*	Benzyl carbiny acetate; 2-Phenylethyl acetate
P029	Phenethyl alcohol	2-Phenylethyl alcohol; Benzylmethanol; 1-Phenyl-2-ethanol; 2-Phenylethan-1-ol; Benzyl carbinol; 2-Phenylethanol; phenylethyl alcohol; β -Phenyethyl alcohol
P030	Phenethyl amine	2-Aminoethylbenzene; 2-Phenylethylamine; β -Phenylethylamine; 1-amino-2- phenylethane; β -Aminoethyl benzene
P031	Phenethyl anthranilate	2-Phenylethyl anthranilate; Benzyl carbiny anthranilate; β -Phenylethyl-o- aminobenzoate
P032	Phenethyl benzoate	Benzylcarbiny benzoate; 2-Phenylethyl benzoate
P033	Phenethyl butyrate	2-Phenylethyl butyrate; benzylcarbiny butyrate; 2-Phenylethyl butanoate; β -Phenethyl-n-butanoate
P034	Phenethyl cinnamate	2-phenylethyl cinnamate; β -Phenethyl- β -phenylacrylate; Benzylcarbiny 3-phenylpropenoate; 2-Phenylethyl 3-phenylpropenoate; Benzyl carbiny cinnamate; Phenylethyl- β -phenylacrylate; β -Phenethyl-3-phenylpropenoate; Benzylcarbiny cinnamate
P035	Phenethyl formate	2-Phenylethyl methanoate; Benzylcarbiny methanoate; Phenylethyl formate; Benzyl carbiny formate; Phenethyl methanoate; 2-Phenylethyl formate

Order	General Name	Synonyms
P036	Phenethyl hexanoate	Benzylcarbinyloctanoate; 2-phenylethyl caprylate; Phenyl ethyl caproate; β -phenethyl hexoate; benzyl carbinyloctylate; Benzylcarbinyloctanoate; 2-Phenethyl hexanoate; 2-Phenylethyl caproate; 2-Phenylethyl hexanoate; Benzylcarbinyloctanoate
P037	Phenethyl isobutyrate	Benzylcarbinyloctanoate; Phenethyl 2-methylpropanoate; Benzylcarbinyloctanoate; 2-Phenylethyl isobutyrate
P038	Phenethyl isothiocyanate	Benzene, (2-isothiocyanatoethyl)-, Isothiocyanic acid, phenethyl ester; β -Phenethyl isothiocyanate; 2-Phenylethyl isothiocyanate; Phenethyl mustard oil
P039	Phenethyl isovalerate	Phenethyl isovalerianate; Benzylcarbinyloctanoate; Benzylcarbinyloctanoate; 2-phenylethyl 3-methylbutanoate; benzylcarbinyloctanoate; Benzyl carbinyloctanoate; Phenethyl isopentanoate; Phenethyl-3-methylbutyrate; 2-phenylethyl isovalerate
P040	Phenethyl mercaptan	2-Phenylethane-1-thiol; 2-Phenylethanethiol; 2-Phenethylthiol; 2-Phenylethanethiol
P041	Phenethyl octanoate	Phenyl ethyl caprylate; Phenethyl octoate; phenyl ethyl octanoate; Benzyl carbinyloctylate; 2-Phenylethyl octanoate, Benzylcarbinyloctanoate; 2-Phenylethyl caprylate
P042	Phenethyl phenylacetate	2-Phenylethyl α -toluate; Benzylcarbinyloctanoate; Benzyl carbinyloctanoate; 2-Phenylethyl phenylacetate; phenethyl- α -toluate
P043	Phenethyl propionate	2-Phenylethyl propanoate; Benzyl carbinyloctanoate; 2-Phenylethyl propionate; Phenylethyl propionate
P044	Phenethyl salicylate	2-Phenylethyl 2-hydroxybenzoate; Benzylcarbinyloctanoate; Benzyl carbinyloctanoate; Phenethyl-2-hydroxybenzoate; Phenethyl-o-hydroxybenzoate; 2-Phenylethyl salicylate; 2-Phenylethyl salicylate; Benzylcarbinyloctanoate

Order	General Name	Synonyms
P045	Phenethyl senecioate	2-Phenylethyl senecioate; 2-Phenylethyl 3-methyl-2-butenolate; 2-Phenethyl 3-methylcrotonate; Phenethyl-3,3-dimethylacrylate; Phenethyl-3-methyl-2-butenolate; phenethyl-3-methylcrotonate; Phenethyl 3,4-dimethylacrylate
P046	Phenethyl tiglate	2-Phenylethyl tiglate; 2-Phenylethyl-trans-2-methylbutenoate; 2-Phenylethyl- rans-2,3-dimethylacrylate; Phenethyl 2-methylcrotonate; Benzyl carbonyl tiglate; Phenethyl trans-2,3-dimethylacrylate; Phenethyl trans-2-methylbutenoate; Phenethyl trans-2-methylcrotonate; Phenylethyl tiglate; (E)-2-Phenylethyl 2-methylbutenoate
P047	Phenol	Carbolic acid; Benzenol; Hydroxybenzene; Phenic or phenylic acid; Phenyl hydroxide; oxybenzene
P048	Phenoxyacetic acid	phenylium; Glycoic acid phenyl ether; Phenoxyethanoic acid; o-Phenylglycolic acid
P049	2-Phenoxyethyl isobutyrate	2-Phenoxyethyl 2-methylpropanoate; Ethyleneglycol monophenylether, isobutyrate; 2-Phenoxyethyl isobutanoate; Phenylcellosolve isobutyrate; Phenoxyethyl isobutyrate; Floranol
P050	Phenyl acetate	(Acetyloxy)benzene; Phenol acetatel; Acetoxybenzene; Acetic acid, phenyl ester; Phenol acetate; Acetoxybenzene
P051	Phenyl disulfide	Diphenyl disulfide; phenyldithiobenzene; Biphenyl disulfide
P052	Phenyl salicylate	Phenyl-2-hydroxybenzoate; 2-Hydroxybenzenoic acid, Phenyl ester; Salol
P053	1-Phenyl-(3 or 5)-propylpyrazole	1-Phenyl-3 or 5-propyl-1,2-diazole; 1-Phenyl-3 or 5-propyl-1,2-diaxole; 1H-pyrazole, 1-phenyl-3(or 5)-propyl-

Order	General Name	Synonyms
P054	1-Phenyl-1,2-propanedione	Phenyl methyl diketone; Acety benzoyl; Methyl phenyl diketone; Methyl phenyl glyoxal
P055	1-Phenyl-1-propanol	α -Ethylbenzyl alcohol; α -Hydroxypropylbenzene; 1-Phenylpropyl alcohol; Dihydro isocinnamic alcohol; Dihydro- α -phenyl allyl alcohol; Ethyl phenyl carbinol; phenyl ethyl carbinol; sec-Phenyl propyl alcohol; 1-Phenylpropanol
P056	3-Phenyl-1-propanol	Dihydrocinnamyl alcohol; Benzyl ethyl alcohol; Hydrocinnamyl alcohol; Phenyl propyl alcohol; 3-Phenylpropanol, Phenethyl carbinol; 3-hydroxy-1-phenylpropane; (3-Hydroxypropyl)benzene
P057	4-Phenyl-2-butanol	Methyl 2-phenylethyl carbinol; Methyl phenylethyl carbinol; Phenylethyl methyl carbinol
P058	2-Phenyl-2-butenal	2-Phenyl crotonaldehyde; 2-Phenyl-but-2-en-1-al
P059	4-Phenyl-2-butyl acetate	1-Methyl-3-phenylpropyl acetate; Phenylethyl methyl carbonyl acetate; 1-Methyl-3- phenylpropyl acetate; Methyl phenyl ethyl carbonyl acetate; 4- Phenyl-2-butyl acetate
P060	2-Phenyl-3-(2-furyl) prop-2-enal	3-(2-Furyl)-2-phenylprop-2-enal; Benzeneacetaldehyde, α -(2-furanylmethylene)-, (E)-; 2-Furfurylidenephenylacetaldehyde
P061	4-Phenyl-3-buten-2-ol	Methyl styryl carbinol; Homocinnamyl alcohol; α - Methylcinnamyl alcohol
P062	4-Phenyl-3-buten-2-one	Benzilideneacetone; Benzylidene acetone; cinnamyl methyl ketone; Methyl styryl ketone; Methyl cinnamyl ketone; 4- Phenylbut-3-en-2-one; Acetocinnamone; Benzalacetone

Order	General Name	Synonyms
P063	2-Phenyl-3-carbethoxyfuran	Ethyl 2-phenyl-3-furoate; 3-furanecarboxylic acid, 2-phenyl-, ethyl ester; Phenyl oxaromate
P064	1-Phenyl-3-methyl-3-pentanol	3-Methyl-1-phenylpentan-3-ol; Methyl ethyl phenylethyl carbinol; 3-methyl-1-phenyl- -entanol; Phenylethyl methyl ethyl carbinol; 3-Methyl-1-phenyl-3-pentanol;
P065	(+/-)-2-Phenyl-4-methyl-2-hexenal	Benzeneacetaldehyde, α -(2-methylbutylidene)-; 2-Hexenal, 4-methyl-2-phenyl-
P066	3-Phenyl-4-pentenal	3-Phenyl-3-vinylpropionaldehyde; β -Vinylhydrocinnamaldehyde
P067	2-Phenyl-4-pentenal	Benzeneacetaldehyde, α -2-propenyl
P068	Phenylacetaldehyde	Phenylacetic aldehyde; benzylcarboxaldehyde; Hyacinthin; 1-Oxo-2-phenylethane; α -Toluic aldehyde; α -Tolualdehyde; α -toly aldehyde; Phenylacetic aldehyde; Benzylcarboxyaldehyde,1-Oxo-2-
P069	Phenylacetaldehyde 2,3-butylene glycol acetal	2-Benzyl-4,5-dimethyl-1,3-dioxane; 4,5-Dimethyl-2-benzyl-1,3-dioxolan; 2-Benzyl- ,5-dimethyl-1,3-dioxolane
P070	Phenylacetaldehyde diisobutyl acetal	1,1-Diisobutoxy-2-phenylethane; 1,1-Di(2-methylpropoxy)-2-phenylethane
P071	Phenylacetaldehyde dimethyl acetal	Viridine; rosal; Vertodor; 1,1-Dimethoxy-2-phenylethane; α -Toluic aldehyde dimethylacetal; α -Tolyl aldehyde dimethyl acetal
P072	Phenylacetaldehyde glyceryl acetal	5-Hydroxy-2-benzyl-1,3-dioxane and 4-hydroxymethyl-2-benzyl-1,3- dioxolane mixture); 5-Hydroxymethyl-2-

Order	General Name	Synonyms
		benzyl-1,3-dioxolane; 5-Hydroxymethyl-2- benzyl-1,3-dioxolane
P073	Phenylacetic acid	Benzylcarboxylic acid; α -Toluic acid
P074	(+/-)-1-Phenylethylmercaptan	Benzenemethanethiol, α -methyl, (+/-); 1-Phenylethanethiol,(+/-)
P075	5-Phenylpentanol	Benzenepentanol; Phenylamyl alcohol; Benzenepentan-1-ol
P076	2-Phenylphenol	2-Biphenylol; [1,1'-Biphenyl]-2-ol; Dowicide;1, 2-Hydroxy-1,1'-biphenyl; o-Hydroxybiphenyl; o-Phenylphenol; Biphenyl-2-ol; (1-1'-biphenyl)-2-ol; 2-Hydroxydiphenyl; o-Hydroxydiphenyl; Torsite; Xenol; 2-Biphenylol
P077	2-Phenylpropan-1-ol	Hydratropic alcohol; Hydratropyl alcohol; 2-Phenylpropyl alcohol; b-Methylphenethyl alcohol
P078	3-Phenylpropionaldehyde	3-Phenylpropanal; Benzyl acetaldehyde; Dihydrocinnamic aldehyde; hydrocinnamaldehyde; hydrocinnamic aldehyde; β -Phenyl propionaldehyde; β -Phenyl propionaldehyde; Phenylpropyl aldehyde; Benzenepropanal
P079	3-Phenylpropionic acid	β -Phenylpropionic acid; Dihydrocinnamic acid; Benzylacetic acid; Hydrocinnamic acid; γ -phenylpropionic acid; Benzenepropanoic acid
P080	3-Phenylpropyl acetate	β -Phenylpropyl acetate; Phenylpropyl acetate; Hydrocinnamyl acetate; Benzenepropanol acetate; 3-Phenyl-1-propyl acetate
P081	2-Phenylpropyl butyrate	Hydratropyl butyrate; β -methyl phenethyl butyrate; α -Phenylpropyl alcohol, butyric ester; 2-Phenylpropyl- <i>n</i> -butyrate
P082	3-Phenylpropyl cinnamate	Hydrocinnamyl 3-phenylpropenoate; β -Phenylpropyl cinnamate; 3-Phenylpropyl 3-phenylpropenoate; Hydrocinnamyl cinnamate; 3-Phenylpropyl- β -phenylacrylate; 3-Phenylpropyl-3-phenyl-2-propenoate;

Order	General Name	Synonyms
		Phenylpropyl cinnamate
P083	3-Phenylpropyl formate	Hydrocinnamyl methanoate; β -Phenylpropyl formate; 3-Phenylpropyl methanoate; Hydrocinnamyl formate; 3-Phenyl-1-propyl methanoate; Benzenepropanol formate; Phenylpropyl formate
P084	3-Phenylpropyl hexanoate	Hydrocinnamyl caproate; Hydrocinnamyl hexanoate; 3-Phenylpropyl caproate; Phenylpropyl capronate; phenylpropyl hexylate
P085	2-Phenylpropyl isobutyrate	Hydratopyl isobutyrate; α -Phenylpropyl alcohol, isobutyric ester; 2-Methyl-2-phenylethyl 2-methylpropanoate; Hydratopyl 2-methylpropanoate; 2-Phenylpropyl 2-methylpropanoate; 2- α -Phenylpropyl alcohol, isobutyric ester
P086	3-Phenylpropyl isobutyrate	3-phenylpropyl 2-methylpropanoate; β -phenylpropyl 2-methylpropanoate; hydrocinnamyl 2-methylpropanoate; Hydrocinnamyl isobutyrate
P087	3-Phenylpropyl isovalerate	3-Phenylpropyl isovalerianate; Hydrocinnamyl 3-methylbutanoate; 3-phenylpropyl 3-methylbutanoate; 3-Phenylpropyl isopentanoate; β -Phenylpropyl 3-methylbutanoate; Hydrocinnamyl isovalerate; 3-Phenylpropyl- β -methylbutyrate; 3-Phenylpropyl isovaleriate
P088	3-Phenylpropyl propionate	Hydrocinnamyl propionate; 3-Phenylpropyl propanoate; β -Phenylpropyl propionate; Benzenepropanol propionate; Phenylpropyl propionate; β -Phenylpropyl propanoate
P089	2-(3-Phenylpropyl)pyridine	Pyridine, 2-(3-phenylpropyl)-
P090	2-(3-Phenylpropyl)tetrahydrofuran	2-Hydrocinnamyl tetrahydrofuran; α -(3-Phenylpropyl)-tetrahydrofuran
P091	Phthalide	2-Hydroxymethylbenzoic acid γ lactone; α -Hydroxy-o-toluic acid lactone; 1(3H)-Isobenzofuranone

Order	General Name	Synonyms
P092	Phytol	
P093	Phytyl acetate	
P094	3-Pinanone	Isopinocampone; Bicyclo[3.1.1]heptan-3-one, 2,6,6-trimethyl-
P095	Pine tar oil	
P096	2(10)-Pinen-3-ol	Bicyclo[3.1.1]heptan-3-ol, 6,6-dimethyl-2-methylene-; 6,6-Dimethyl-3-hydroxy-2-methylenebicyclo(3.1.1)heptane; pinocarveol; Pinocarveol; 2(10)-Pinenol-3
P097	α -Pinene	Pinene; Pin-2(3)-enel; 2-Pinene; 2,6,6-Trimethylbicyclo-(3,1,1)-2-heptene; Pin-2(3)-ene
P098	β -Pinene	6,6-Dimethyl-2-methylenebicyclo -(3,1,1)-heptane; Pseudopinene; Pin-2(10)-ene; 6,6-Dimethyl-2-methylene norpinane; nopinene; 2(10)-pinene
P099	Piperazine	1,4-Diazocyclohexane; 1,4-Piperazine; Antiren; Diethylenediamine; Dispermine; Eraverm; Hexahydropyrazine; Lumbrical; Piperizidine; Pipersol; Pyrazine hexahydride
P100	Piperidine	Hexahydropyridine; Hexazane; Pentamethylenimine
P101	Piperine	Piperoylpiperidine; 1-Piperolypiperidine
P102	Piperitenone oxide	7-Oxabicyclo[4.1.0]heptan-2-one, 6-methyl-3-(1-methylethylidene)-; 1,2-Epoxy-p- menth-4-(8)-en-3-one

Order	General Name	Synonyms
P103	Piperitone	d-piperitone; α -piperitone; 1-Methyl-4-isopropyl-1-cyclohexen-3-one; 4-Propyl-iso-1-ethyl-1-cyclohexen-3-one; p-Menth-1-en-3-one; 4-isopropyl-1-methyl-1-cyclohexen-3-one; 6-Isopropyl-3-methylcyclohex-2-enone
P104	L-Piperitone	2-Cyclohexen-1-one, 3-Methyl-6-isopropyl, (6R)-; 2-Cyclohexen-1-one, 3-methyl-6-(1-methylethyl)-, (6R)-; p-Menth-1-en-3-one; (-)-Piperitone
P105	Piperonal *	Dioxymethylene protocatechuic aldehyde; Heliotropine; 3,4-methylenedioxybenzaldehyde; piperonylaldehyde; Protocatechualdehyde methylene ether
P106	Piperonyl acetate	Heliotropin acetate; 1,3-Benzodioxole-5-methanol, acetate; Heliotropyl acetate; 3,4-Methylenedioxybenzyl acetate
P107	Piperonyl acetone	4-(3,4-methylenedioxyphenyl)2-butanone; Dulcinyll; 2-Butanone, 4-(1,3-benzodioxol-5-yl); Dulcinyll; Heliotropyl acetone
P108	Piperonyl isobutyrate	3,4-Methylenedioxybenzyl 2-methylpropanoate; piperonyl 2-methylpropanoate; heliotropyl 2-methylpropanoate; Heliotropyl isobutyrate; 3,4-Methylenedioxybenzyl isobutyrate; Piperonyl 2-methylpropionate
P109	Polylimonene	
P110	Potassium 2-(1'-ethoxy)ethoxypropanoate	1-Ethoxyethyl ether of potassium lactate; potassium <i>O</i> -(1'-ethoxy)ethoxypropanoate
P111	Potassium acetate	
P112	Prenyl caproate	Hexanoic acid, 3-methyl-2-butenyl ester
P113	Prenyl acetate	3-Methylbuten-2-yl acetate, 2-Buten-1-ol, 3-methyl-, acetate; 2-Buten-1-ol, 3-methyl-, acetate; 3-Methyl-2-butenyl acetate

Order	General Name	Synonyms
P114	Prenyl benzoate	Benzoic acid, hexyl ester; 2-Buten-1-ol, 3-methyl-, benzoate; 3-Methyl-2-butenyl benzoate; Benzoic acid, 3-methyl-2-butenyl ester
P115	Prenyl formate	2-Buten-1-ol, 3-methyl-,formate; Methanoic acid, 3-methyl-2-butenyl ester
P116	Prenyl isobutyrate	Propanoic acid, 2-methyl-, 3-; Methyl-2-butenyl ester; Isobutyric acid, 3-methyl-2- butenyl ester
P117	Prenyl thioacetate	S-Prenyl thioacetate; S-(3-methyl-2-butenyl)acetothioate, S-3-methyl-2-butenyl ethanethioate; 3-methyl-3-butenyl thioacetate; Ethanethioic acid, S-(3-methyl-2-buten-1-yl) ester; Thioacetic acid, S-(3-methyl-but-2-en-1-yl) ester
P118	Prenylthiol	3-Methyl-2-buten-1-thiol, Prenyl mercaptan; 3-Methyl-2-butenyl mercaptan; 3-Methyl-2-butenthiol-1
P119	1,2-Propanedithiol	1,2- Dimercaptopropane
P120	1,3-Propanedithiol	1,3-Dimercaptopropane; trimethylene dimercaptan
P121	Propanethiol	n-Thiopropyl alcohol; n-Propyl mercaptan; Propylthiol; 1-Propanethiol; 1-Propane- 1-thiol; Propyl mercaptan
P122	2-Propanethiol	Isopropyl mercaptan
P123	Propenyl propyl disulfide	1-Propenyl propyl disulfide; Prop-1-enyl propyl disulfide
P124	Propenyl-2,6-dimethoxyphenol	4-Prophenyl-2,6-dimethoxy phenol; 2,6-Dimethoxy-4-prop-1-enylphenol; 6-Methoxyisoeugenol; phenol, 2,6-dimethoxy-4-(1-propenyl)-, (E)-; 4-propenylsyringol

Order	General Name	Synonyms
P125	Propenylguaethol	Vanitrope; Ethoxyprop-3-enylphenol; 6-Ethoxy-m-anol; 1-ethoxy-2-hydroxy-4- propenylbenzene; 2-Ethoxy-5-propenylphenol; hydroxymethyl anethole; 2-Propwnyl-6 -ethoxyphenol; 6- Ethoxyprop-3-enylphenol; 5-Propenylguaethol; 3-Propenyl-6- ethoxyphenol
P126	(Z)-4-Propenylphenol	Phenol, 4-(1-propenyl)-isochavicol
P127	Propionaldehyde	Methylacetaldehyde; Propanal; Propyl aldehyde; Propion aldehyde; Propan-1-al; Aldehyde c-3
P128	Propionic acid*	Methylacetic acid; Ethylformic acid; Propanoic acid
P129	2-Propionyl-2-thiazoline	1-Propanone, 1-(4,5-dihydro-2-thiazoly)-; 1-(4,5-Dihydro-1,3-thiazol-2-yl)-1- propanone; 1-Propanone, 1-(2-thiazolin-2-yl)-
P130	2-Propionylpyrrole	Ethyl 2-pyrrolyl ketone; 1-(2-Pyrrolyl)-1-propanone
P131	2-Propionylpyrroline	1-(3,4-Dihydro-2H-pyrrol-5-yl)-1-propanone
P132	2-Propionylthiazole	1-Propanone, 1-(5-methyl-2-furanyl)-; 1-(2-Thiazoly)-1-propanone; Thiazole, 2-propionyl-
P133	Propiophenone	Phenyl ethyl ketone; 1-phenyl-1-propanone; 1-Propanone, 1-phenyl-; Propionylbenzene; 1-Phenyl-1-propanone, Ethyl phenyl ketone; Propiophenone
P134	Propyl 2,4-decadienoate	Propyl deca-2,4-dienoate
P135	Propyl 2-furanacrylate	Propyl-3-(2-furyl)-2-propenoate; Propyl 3-(2-furyl)acrylate; Propyl β -furylacrylate; propyl-3-furylpropenoate; propyl 3(2-furyl)propenoate; Propyl furanacrylate; Propyl furylacrylate
P136	Propyl 2-furoate	Furancarboxylic acid, propyl ester; propyl furan-2-carboxylate; <i>n</i> -Propyl pyromucate; 2-Furoic acid; n-Propyl furan-2-carboxylate

Order	General Name	Synonyms
P137	Propyl 2-mercaptopropionate	2-Mercaptopropanoic acid, propyl ester; Propyl 2-sulfanylpropanoate
P138	Propyl 2-methyl-3-furyl disulfide	2-Methyl-3-furyl propyl disulfide; 2-Methyl-3-(propyldithio)furan
P139	Propyl acetate	Propyl ethanoate; n-Propyl acetate
P140	Propyl alcohol	Ethylcarbinol; Albacol; optal; 1-Propanol; Propylic alcohol; n-Propyl alcohol; n-propanol; Propylic alcohol; Propan-1-ol
P141	p-Propyl anisole	4-Propylmethoxybenzene; 1-Methoxy-4-propylbenzene; Dihydroanethole; 1-Methoxy- 4-n-propylbenzene; Methyl p-propylphenyl ether; Propylmethoxybenzene; p-Propylanisole; p-n-Propyl anisole; 4-Propylmethoxybenzene;
P142	Propyl benzoate	n-Propyl benzenecarboxylate; n-Propyl benzoate; Propyl phenyl methanoate
P143	Propyl butyrate	<i>n</i> -Propyl- <i>n</i> -butanoate; <i>n</i> -Propyl butyrate; Propyl butanoate
P144	Propyl cinnamate	n-Propyl cinnamate; Propyl- β -phenyl acrylate; Propyl-3-phenylpropenoate; n-Propyl 3-phenylpropenoate; n-Propyl β -phenylacrylate
P145	Propyl disulfide	
P146	Propyl formate	<i>n</i> -Propyl formate; <i>n</i> -Propyl methanoate
P147	propyl furfuryl disulfide	2-[(propyldithio)methyl]-furan; Furfuryl propyl disulfide

Order	General Name	Synonyms
P148	Propyl heptanoate	<i>n</i> -Propyl heptoate; <i>n</i> -propyl heptylate; Propyl heptylate; Propyl heptoate; Propyl oenanthate
P149	Propyl hexanoate	<i>n</i> -Propyl caproate; <i>n</i> -Propyl- <i>n</i> -hexoate; <i>n</i> -Propyl hexylate; Propyl caproate
P150	Propyl isobutyrate	<i>n</i> -Propyl isobutyrate; <i>n</i> -Propyl-2-methylpropanoate
P151	Propyl isovalerate	Propyl isovalerianate; Propyl 3-methylbutanoate; Propyl isopentampate; propyl 3-methylbutyrate; <i>n</i> -Propyl isovalerate; <i>n</i> -propyl- β -methylbutyrate; <i>n</i> -propyl methylbutyrate
P152	Propyl phenylacetate	<i>n</i> -Propyl- α -toluate; Propyl α -toluate; Propyl α -Toluate
P153	Propyl <i>p</i> -hydroxybenzoate	Propyl 4-hydroxybenzoate; Benzoic acid, <i>p</i> -hydroxy-, propyl ester; Preserval P; propyl chemosept; Propylparasept; Propylparaben
P154	Propyl propionate	Propyl propanoate; <i>n</i> -Propyl propionate
P155	Propyl thioacetate	Acetic acid, thiopropyl ester; S-propyl thioacetate, Propanethiol acetate; Ethanethioic acid, S-propyl ester
P156	4-Propyl-2,6-dimethoxyphenol	2,6-Dimethoxy-4-propylphenol; Phenol, 2,6-dimethoxy-4-propyl; 4-Propylsyringol
P157	Propylamine	1-Aminopropane; 1-Propylamine; Mono- <i>n</i> -propylamine; Monopropylamine; <i>n</i> -Propylamine; Propan-1-ylamine
P158	Propylene glycol dibenzoate	1,2-Propanediol dibenzoate
P159	Propylene glycol stearate	Propylene glycol monostearate; Propylene glycol octadecanoate; Octadecanoic acid, 2-hydroxypropyl ester; Propylene glycol mono-octadecanoate
P160	3-Propylidene-phthalide	Celeiax

Order	General Name	Synonyms
P161	α -Propylphenethyl alcohol	Benzylpropyl carbinol; Benzylbutyl alcohol; Benzyl-n-propyl carbinol; 1-Phenyl-2-pentanol; 1-phenylpentan-2-ol; n-propyl benzyl carbinol
P162	o-Propylphenol	1-(2-Hydroxyphenyl)propane; phenol, 2-propyl-; 2-Propylphenol
P163	p-Propylphenol	Phenol, 4-propyl-; 4-Propylphenol; 1-(4-Hydroxyphenyl)propane
P164	2-Propylpyrazine	Propylpyrazine, 2-propyl-1,4-diazine
P165	2-Propylpyridine	
P166	Pulegone	1-Methyl-4-isopropenylidene-3-cyclohexanone; δ -4(8)-p-menthen-3-one; 1-Isopropylidene-4-methyl-2-cyclohexanone; p-Menth-4(8)-en-3-one; 1-methyl-4-isopropylidenecyclohexan-3-one; 5-Methyl-2-(1-methylethylidene)cyclohexanone
P167	Pyrazine	p-Diazine; 1,4-Diazine; Piazine; Paradiazine; 1,4-Diazabenzene; d-Diazine
P168	Pyrazineethanethiol	Pyrazinyl ethanethiol; 2-(Pyrazinyl)ethanethiol; 2-pyrazinyl ethylmercaptan
P169	Pyrazinyl methyl sulfide	Pyrazinylmethyl methyl sulfide; 2-methylthiopyrazine; Methylthioprazine; Pyrazinylmethyl methyl sulphide
P170	Pyridine	Azine; Azabenzene
P171	2-Pyridine methanethiol	2-Pyridylmethanethiol; 2-Pyridylmethyl mercaptan; 2-Mercaptomethylpyridine
P172	Pyroligneous acid	
P173	Pyroligneous acid extract	Pyroligneous vinegar; Wood vinegar

Order	General Name	Synonyms
P174	Pyrrrole	Azloe; imidole; Divynyleneimine
P175	Pyrrolidine	Tetrahydropyrrole; Tetramethylenimine
P176	1-Pyrroline	3,4-dihydro-(2H)-pyrolle
P177	Pyruvaldehyde	2-Ketopropionaldehyde; Acetyl formaldehyde; 1,2-ketopropionic aldehyde; α -ketopropionic aldehyde; Methyl glyoxal; 2-Oxopropanal; Pyruvic aldehyde; Propan-2-on-1-al
P178	Pyruvic acid	2-Ketopropionic acid; Acetylformic acid; α -Ketopropionic acid; 2-Oxopropanoic acid; Pyroracemic acid
P179	1-Phenylbutan-1,3-dione	α -Acetylacetophenone; Acetoacetophenone; cetylbenzoylmethane; Benzoylacetone; 1-Benzoyl-2-propanone; ; 2-Acetylacetophenone; 2-Propanone, benzoyl-; 1-Benzoylacetone; Benzoyl-aceton;1,3-Butanedione, 1-phenyl-;1-Phenyl-1,3-butanedione
P180	3-Pentanone	Diethyl ketone; 1,3-Dimethylacetone; Ethyl Ketone; Metacetone;Methacetone; Propione; Ethyl propionyl; Pentan-3-one;Diethylcetone; Pentanone-3; Dimethylacetone
P181	1-Phenylpropan-2-one	2-Propanone, 1-phenyl-; Methyl benzyl ketone; Phenyl-2-propanone; Phenylacetone; 1-Phenyl-2-propanone; 3-Phenyl-2-propanone; α -Phenylacetone; Phenylmethyl methyl ketone; 1-Phenylacetone;Benzyl methyl ketone
P182	Prop-2-en-1-ol	Allyl alcohol; Allylic alcohol; Vinylcarbinol; 1-Propen-3-ol; 2-Propenol; 2-Propenyl alcohol; 3-Hydroxypropene; Propenol; Propen-1-ol-3; Propenyl alcohol; 1-Propenol-3; 2-Propene-1-ol; 3-Hydroxy-1-propene; 1-Propenol-3-ol; Propene-1-ol; Propenol-3; 4-Quinolinecarboxylic acid, 2-phenyl-; 2-propen-1-ol (allyl alcohol);2-Propen-1-ol
P183	1-Pentanethiol	n-Amyl mercaptan; n-Pentyl mercaptan; Amyl hydrosulfide; Amyl mercaptan; Amyl sulfhydrate; Amyl thioalcohol; Pentane-1-thiol; Pentanethiol; Pentyl mercaptan; 1-Mercaptopentane; Mercaptan amylique; Pentalarm;1-Pentanthiol
P184	1,5-Pentanedioic acid	Glutaric acid; 1,3-Propanedicarboxylic acid; Pentandioic acid;Pentanedioic acid
P185	Pentan-2,4-dione	2,4-Pentanedione; Acetoacetone; Diacetylmethane; 2-Propanone, acetyl-; 2,4-Dioxopentane; 2,4-Pentadione;Pentane-2,4-dione;Acetone, acetyl-;Pentanedione; Pentanedione-2,4; Acetyl 2-propanone;2,4-

Order	General Name	Synonyms
		Pentandione;Acetylacetone
P186	Propyl valerate	Valeric acid, propyl ester; n-Propyl n-valerate; Propyl pentanoate; n-propyl pentanoate;Pentanoic acid, propyl ester
P187	Pseudoionone	ψ-Ionone; Citrylideneacetone;6,10-Dimethyl-3,5,9-undecatrien-2-one; 2,6-Dimethylundeca-2,6,8-triene-10-one; (3E,5E)-6,10-Dimethyl-3,5,9-undecatrien-2-one; 2,6-Dimethyl hendeca-2,6,8-trien-10-one
P188	1,2,3,5,6-pentathiepane	Lenthionine; Lenthionin
P189	2-Phenylpropionic acid	2-Phenylpropanoic acid; α-Phenylpropionic acid; α-Methylphenylacetic acid; Hydratropic acid; dl-α-Phenylpropionic acid; α-Methylbenzeneacetic acid; Propanoic acid, 2-phenyl;Benzeneacetic acid, α-methyl-
P190	1-Phenylbutan-1-one	Butyrophenone; n-Butyrophenone; Phenyl propyl ketone; Propyl phenyl ketone;1-Butanone, 1-phenyl-;1-Phenyl-1-butanone
P191	β-Phellandrene	Cyclohexene, 3-methylene-6-(1-methylethyl)-; p-Mentha-1(7),2-diene; Phellandrene, β; 3-Isopropyl-6-methylene-1-cyclohexene; 3-methylene-6-(1-methylethenyl)-cyclohexane
P192	Pentan-3-ol	Diethyl carbinol; 3-Pentyl alcohol; sec-Amyl alcohol; Pentanol-3;3-Pentanol
P193	Propyl lactate	Propanoic acid, 2-hydroxy-, propyl ester; propyl 2-hydroxypropanoate
P194	2-Phenylpropan-2-ol	Benzyl alcohol, α,α-dimethyl-; α-Cumyl alcohol; α,α-Dimethylbenzyl alcohol; Dimethylphenylcarbinol; Dimethylphenylmethanol; 1-Hydroxycumene; 2-Phenyl-2-propanol; 2-Propanol, 2-phenyl-; α,α-Dimethylbenzenemethanol; Phenyl dimethylcarbinol; 2-Phenylisopropanol; 1-Methyl-1-phenylethanol; Benzenemethanol, α,α-dimethyl-
P195	Propyl octanoate	Octanoic acid, propyl ester; n-Propyl n-octanoate; n-propyl octanoate
P196	Pentyl acetate	n-Amyl acetate; n-Pentyl acetate; Amyl acetate; Birnenoel; Acetic acid, amyl ester; Amyl acetic ester; Amyl acetic ether; Banana oil; Pear oil; Pent-acetate; 1-Pentanol acetate; 1-Pentyl acetate; Acetic acid n-amyl ester; n-Pentyl

Order	General Name	Synonyms
		ethanoate; Pentyl ester of acetic acid; Acetic acid, n-pentyl ester; 1-Acetoxy-pentane; Primary amyl acetate; Acetic acid, pentyl ester
P197	Pentadecane	n-Pentadecane
P198	Pentadecan-1-ol	n-Pentadecanol; n-1-Pentadecanol; Pentadecyl alcohol; Pentadecanol-(1); 1-Pentadecanol; Pentadecanol
P199	Pent-4-en-1-ol	4-Pentenol; 4-Pentenyl alcohol; 4-Pentene-1-ol; 4-Penten-1-ol
P200	Pentadecanoic acid	Pentadecylic acid; n-Pentadecanoic acid; n-Pentadecylic acid; Pentadecanoic (Palmitic) acid
P201	Propyl propane thiosulfonate	1-Propanesulfonothioic acid, S-propyl ester
P202	4-Pentenal	Pent-4-enal
P203	Propyl hexadecanoate	Hexadecanoic acid, propyl ester; Propyl palmitate
P204	Pentyl 2-methylpropanoate	Isobutyric acid, pentyl ester; Amyl isobutyrate; Pentyl isobutyrate; 1-Pentyl isobutyrate; N-Amyl iso-butyrate;

Order	General Name	Synonyms
		Pentyl iso-butyrate; Pentyl isobutanoate;n-Pentyl isobutyrate;Propanoic acid, 2-methyl-, pentyl ester
P205	4-Phenylbutan-2-one	2-Butanone, 4-phenyl-; Benzylacetone; Methyl phenethyl ketone; Methyl 2-phenylethyl ketone; Phenethyl methyl ketone; 1-Phenyl-3-butanone; Methyl phenylethyl ketone; β -Phenylethyl methyl ketone; 4-phenyl-2-butanone (benzyl acetone); 4-phenylbutanone;4-Phenyl-2-butanone
P206	Propyl dodecanoate	Dodecanoic acid, propyl ester;Propyl laurate
P207	2-Propylfuran	Furan, α -propyl-; 2-n-Propylfuran;Furan, 2-propyl-
P208	2-Pentylthiophene(2-Amylthiophene)	Thiophene, 2-pentyl-; 2-n-Amylthiophene; 2-n-Pentylthiophene
P209	Patchoulol	1,6-Methanonaphthalen-1(2H)-ol, octahydro-4,8a,9,9-tetramethyl-, [1R-(1 α ,4 β ,4 α ,6 β ,8 α)]-; 1,6-Methanonaphthalen-1 β (2H)-ol, 3,4,4a β ,5,6 β ,7,8,8a-octahydro-4 α ,8a β ,9,9-tetramethyl-; Patchoulic alcohol; Patchoulol; 1,6-Methanonaphthalen-1(2H)-ol, octahydro-4,8a,9,9-tetramethyl-, (1 α ,4 β ,4 α ,6 β ,8 α)-;Patchoulanol
P210	3-Phenylpropyl butyrate	Butanoic acid, 3-phenylpropyl ester; Butyric acid, 3-phenylpropyl ester; Phenylpropyl butyrate; Phenylpropyl n-butyrate;3-Phenylpropyl butanoate
P211	Phenethyl valerate	2-Phenylethyl pentanoate;Valeric acid, phenethyl ester;Valeric acid, 2-phenylethyl ester; Phenylethyl N-valerate; 2-Phenylethyl pentanoate; phenylethyl pentanoate;Pentanoic acid, 2-phenylethyl ester
P212	Pentyl 2-methylisocrotonate	
P213	Propyl crotonate	2-Butenoic acid, propyl ester; Crotonic acid, propyl ester; Propyl 2-butenolate; Propyl (2E)-2-butenolate;(E)-2-Butenoic acid propyl ester

Order	General Name	Synonyms
P214	4-pentenyl isothiocyanate	pentenyl isothiocyanate
P215	(Z)-2-Pentenol	2-Penten-1-ol;pent-2-en-1-ol
P216	Propyl decanoate	Decanoic acid, propyl ester; n-propyl decanoate
P217	Propyl 2-methylbutyrate	Butanoic acid, 2-methyl-, propyl ester; n-Propyl 2-methyl butyrate;Propyl 2-methylbutanoate
P218	3-Pentenol-1	(3E)-3-Penten-1-ol;3-Penten-1-ol;3-pentenol
P219	5-Pentyl-3H-furan-2-one	4-Hydroxy-3-nonenic acid lactone, 5-(1-pentyl)-3H-furan-2-one, 5-amyl-3H-furan-2-one
P220	2-(trans-2-Pentenyl)cyclopentanone	JASMINONE; (E)-2-(Pent-2-enyl)cyclopentan-1-one,
P221	2-Propyl-4,5-dimethyloxazole(4,5-Dimethyl-2-propyloxazole)	4,5-Dimethyl-2-propyloxazole;4,5-Dimethyl-2-propyl-1,3-oxazole;Oxazole, 4,5-dimethyl-2-propyl-
P222	Phenethyl decanoate	Decanoic acid 2-phenylethyl ester; Phenylethyl n-decanoate;2-Phenylethyl decanoate
P223	Phenethyl crotonate	
P224	2-Pentyl 2-methylpentanoate	1-methylbutyl 2-methylpentanoate

Order	General Name	Synonyms
P225	Pyrrolidino-[1,2E]-4H-2,4-dimethyl-1,3,5-dithiazine	2,4-dimethyltetrahydropyrrolo[2,1-d][1,3,5]-dithiazine;dimethyl pyrrolidino dithiazine
P226	Phenethyl lactate	
P227	Palmitic acid	Hexadecanoic acid; Hexadecylic acid; Cetylic acid; 1-Pentadecanecarboxylic acid
P228	2-Phenylpropanal propyleneglycol acetal	4-Methyl-2-(1-phenylethyl)-1,3-dioxolane; 1,3-Dioxolane, 4-methyl-2-(1-phenylethyl)-; Hydratropic aldehyde propylene glycol acetal
P229	2-Pyrrolidone	2-Pyrrolidinone; pyrrolidin-2-one; 2-Ketopyrrolidine
P230	3-Pentanethiol	3-Pentyl mercaptan; 3-Mercapopentane; Pentane-3-thiol
P231	2-Phenoxyethanol	beta-Phenoxyethanol; 1-Hydroxy-2-phenoxyethane; Ethylene glycol monophenyl ether
P232	2-Phenoxyethyl propionate	2-Phenoxyethyl propanoate

Order	General Name	Synonyms
P233	Phenylacetaldehyde diethyl acetal	(2,2-Diethoxyethyl)benzene; 1,1-Diethoxy-2-phenylethane; Benzeneacetaldehyde, diethyl acetal
P234	Pinocaryyl acetate	6,6-Dimethyl-2-methylenebicyclo[3.1.1]hept-3-yl acetate
P235	Piperonal propyleneglycol acetal	4-(4-Methyl-1,3-dioxolan-2-yl)-1,3-benzodioxole; 4-Methyl-2-(3,4-methylenedioxyphenyl)-1,3-dioxolane
P236	S-Prenyl thioisobutyrate	Propanethioic acid, 2-methyl-, S-(3-methyl-2-buten-1-yl) ester; S-3-Methylbut-2-enyl 2-methylpropanethioate
P237	S-Prenyl thioisopentanoate	S-3-Methylbut-2-enyl 3-methylbutanethioate; Butanethioic acid, 3-methyl-, S-(3-methyl-2-buten-1-yl) ester
P238	1,3-Propanediol	

Order	General Name	Synonyms
P239	1,1-Propanedithiol	1,1-Dimercaptopropane; 1,1-Propanedithiol; Propane-1,1-dithiol
P240	2-Propionylthiophene	
Q001	Quinine bisulfate	
Q002	Quinine hydrochloride	Quinine monohydrochloride; Quinine chloride
Q003	Quinine sulphate	
Q004	Quinoline	1-Benzazine; Benzo(b)pyridine; 2,3-Benzopyridine; chinoleine; Leucoline; 2,3-Benzopyrine; Benzopyrine; Chinolein; 1-Azanepthalene; Leucol
R001	Resorcinol	1,3-Benzenediol; <i>m</i> -dihydroxybenzene; Benzene-1,3-diol; Resorcinol; 1,3- Dihydroxybenzene; <i>m</i> -Dihydroxybenzene
R002	Rhodinol	<i>l</i> -Citronellol; 3,7-dimethyl-6-octen-1-ol; 3,7-Dimethyl-7-octen-1-ol; α -Citronellol; 2,6-Dimethyl-1-octen-8-ol
R003	Rhodinyl acetate	Rhodinyl ethanoate; 3,7-Dimethyl-7-octen-1-yl ethanoate; 3,7-Dimethyl- 7-octen-1-yl acetate; α -Citronellyl acetate
R004	Rhodinyl butyrate	3,7-Dimethyl-6 or 7-octen-1-yl butanoate; Citronellyl butyrate
R005	Rhodinyl formate	3,7-Dimethyl-6 or 7-octen-1-yl formate; Rhodinyl methanoate; 3,7-Dimethyl-6 or 7-octen-1-yl methanoate; Citrinellyl formate; α -Citronellyl formate

Order	General Name	Synonyms
R006	Rhodinyl isobutyrate	Rhodinyl 2-methylpropanoate; 3,7-dimethyl-6 or 7-octen-1-yl 2-methylpropanoate; 3,7-dimethyl-6 or 7-octen-1-yl isobutyrate; Citronellyl isobutyrate
R007	Rhodinyl isovalerate	Rhodinyl isovalerianate; 3,7-Dimethyl-6 or 7-octen-1-yl isovalerate; Rhodinyl 3-methylbutanoate; Rhodinyl isopentanoate; 3,7-Dimethyl-6 or 7-octen-1-yl 3-methylbutanoate; Citronellyl isovalerate; rhodinyl- β -methylbutyrate; 3,7-dimethyl-7-octen-1-yl isopentanoate; Rhodinyl isopentanoate; α -Citronellyl isopentanoate
R008	Rhodinyl phenylacetate	3,7-Dimethyl-6 or 7-octen-1-yl phenylacetate; Citronellyl phenylacetate; rhodinyl α -toluate; 3,7-Dimethyloct-7-enyl 2-phenylacetate; α -Citronellyl phenylacetate
R009	Rhodinyl propionate	3,7-Dimethyl-7-octen-1-yl propanoate; rhodinyl propanoate; 3,7-dimethyl-7-octen-1-yl propionate; Citronellyl propionate; α -Citronellyl propionate
R010	Rum ether	Ethyl oxyhydrate
S001	Salicylaldehyde	Salicylal; 2-Hydroxybenzaldehyde; o-Hydroxybenzaldehyde; Salicylic aldehyde
S002	Santalol (α and β)	12- β -Santalen-14-ol; Argeol; arheol; d- α -santalol; l- β -santalol; 2-Methyl-5-(2,3-dimethyltricyclo[2.2.1.0(2.6)]hept-3-yl)pent-2-en-1-ol and 2-methyl-5-(2-methyl-3-methylenebicyclo[2.2.1]hept-2-yl)pent-2-en-1-ol; β -Santalol; 12- α -Santalen-14-ol
S003	Santalyl acetate (α and β)	α -Santalol, acetate; β -Santalol, acetate; 2-Methyl-5-(2,3-dimethyltricyclo-[2.2.1.0(2.6)]hept-3-yl)pent-2-enyl acetate and 2-methyl-5-(2-methyl-3-methylenebicyclo[2.2.1]hept-2-yl)pent-2-enyl acetate
S004	Santalyl phenylacetate (α and β)	β -Santalyl phenylacetate; α -santalyl phenylacetate; Santalyl α -toluate; α -Santalyl α -toluate; β -santalyl α -toluate; 5-(2,3-Dimethyltricyclo[2.2.1.0(2.6)]hept-3-yl)- 2-methylpent-2-enyl phenylacetate and 2-methyl-5-(2-methyl-3-methylene- bicyclo[2.2.1]hept-2-yl)pent-2-enyl phenylacetate
S005	Sclareolide	Decahydro tetramethylnaphtho-furanone; naphtho[2,1-b]furan-2(1H)-one, decahydro- 3a,6,6,9a-tetramethyl, [3aR-(3a, α ,5a β ,9a α ,9b β); norambrienolide; Decahydrotetramethylnaphtho[2,1b]furan-2(1H)one
S006	β -Sinensal	2,6-dimethyl-10-methylene-2,6,11-dodecatrienal
S007	Skatole	3-Methyl-4,5-benzopyrrole; 3-Methylindole; β -methylindole; 3-methyl(1H)indole; Skatole

Order	General Name	Synonyms
S008	Sodium 2-(4-methoxyphenoxy)propanoate	Sodium 2-(4-methoxyphenoxy)propionate; Propanoic acid, 2-(4-methoxyphenoxy), sodium salt
S009	Sodium 3-mercaptooxopropionate	Sodium 3-mercapto-2-oxopropionate; Sodium mercaptopyruvate; Pyruvic acid, 3-mercapto-, Sodium salt; Sodium 3-mercapto-2-oxopropanote
S010	Sodium 3-methoxy-4-hydroxycinnamate	Sodium 3-(4-hydroxy-3-methoxyphenyl)propenoate; sodium ferulate
S011	Sodium 4-(methylthio)-2-oxobutanoate	4-(Methylthio)-2-oxobutyric acid; 4-(methylthio)-2-oxobutanoic acid; 4-(methylthio)-2- ketobutyric acid
S012	Sodium 4-methoxybenzoyloxy acetate	
S013	Spiro[2,4-dithia-1-methyl-8-oxabicyclo(3.3.0)octane-3,3'-(1'-oxa-2'-methyl)-cyclopentane]	spiro(2,4-Dithia-1-methyl-8-oxa-bicyclo[3.3.0]octane-3,3'-(1'-oxa-2'-methyl)-cyclopentane) and spiro(Dithia-6-methyl-7-oxa-bicyclo[3.3.0]octane-3,3'-(1'-oxa-2'-methyl)-cyclopentane); hexahydro-2',3a-dimethylspiro[1,3]dithiolo(4,5-b)furan-2 ,3'(2'h)furan; Spiro [dithia-6-methyl-7-oxabicyclo [3.3.0] octane-3,3- α -(1- α -oxa-2-methyl)-cyclopentane] (isomere component)
S014	Styrene	Vinylbenzol; Phenylethene; Vinylbenzene; Styrol; Phenylethylene
S015	Sucrose octaacetate	Octoacetyl sucrose; Octaacetyl sucrose
S016	α -Santalene	Tricyclo[2.2.1.0(2,6)]heptane, 1,7-dimethyl-7-(4-methyl-3-pentenyl)-, (-); (-)- α -Santalene; Santalen; Santalene
S017	Sclareol	1-Naphthalenepropanol, α -ethenyldecahydro-2-hydroxy- α ,2,5,5,8a-pentamethyl-, [1r-[1 α (r*),2 β ,4a β ,8a α]]-; Labd-14-ene-8,13-diol, (13R)-; 1-(3-Hydroxy-3-methyl-4-pentenyl)-2,5,5,8a-tetramethyldecahydro-2-naphthalenol

Order	General Name	Synonyms
S018	Sabinene	4(10)-Thujene; Sabinen; (+)-Sabinene; 1-Isopropyl-4-methylenebicyclo[3.1.0]hexane; 1-isopropyl-4-methylenebicyclo[3.1.0]hexane (sabinene); 4-thujene; Sabinene (β -Thujene);Sabenene;Bicyclo[3.1.0]hexane, 4-methylene-1-(1-methylethyl)-
S019	Styryl acetate	
S020	Stearic acid	Octadecanoic acid
T001	α -Terpinene	Terpinene; 1-Methyl-4-propyl(iso)-1,3-cyclohexadiene; p-Menthadiene-1,3; 1,3-p- menthadiene; 1-Methyl-4-isopropyl-1, 3-cyclohexadiene; 1-Methyl-4- isopropylcyclohexadiene-1,3; p-Mentha-1,3-diene
T002	γ -Terpinene	1-Methyl-4-propyl(iso)-1,4-cyclohexadiene; p-mentha-1,4-diene; Crithmene; Moslene; 1,4-p-Menthadiene; 1-Methyl-4-isopropyl-1,4-cyclohexadiene
T003	α -Terpineol	1-p-Menthen-8-ol; Terpeneol schlechthin; α -terpilenol; 1-Methyl-4-proypl-iso-1- cyclohexen-8-ol; p-Menth-1-en-8-ol; 1-methyl-4-isopropyl-1-cyclohexen-8-ol; α -Terpineol; 1-Methyl-4-isopropyl-1-cyclohexen-8-ol; α -Terpilenol; α,α -4- trimethyl-3-cyclohexene-1-methanol
T004	Terpinolene	Tereben; Terpinene; p-Menth-1,4(8)-diene; 1-Methyl-4-isopropylidene-1-cyclohexene; 1,4(8)-terpadiene
T005	Terpinyl acetate	Methen1-1yl-8 acetate; menthen-1-yl-8-acetate; Terpeneol acetate; α -Terpinyl acetate; p-Menth-1-en-8-yl acetate; 3-Cyclohexene-1-methanol, α,α , 4-trimethyl, acetate; Terpeneol acetate
T006	Terpinyl anthranilate	α -Terpinyl anthranilate; p-mentha-1-en-8-yl 2-aminobenzoate; Terpinyl anthranilate; p-Menth-1-en-8-yl anthranilate; Terpinyl-2-aminobenzoate; Terpinyl-o-aminobenzoate

Order	General Name	Synonyms
T007	Terpinyl butyrate	p-Menth-1-en-8-ol butyrate; p-Menth-1-en-8-yl butyrate
T008	Terpinyl cinnamate	p-Menth-1-en-8-yl 3-phenylpropenoate; p-Menth-1-en-8-yl cinnamate; Terpinyl β -phenacrylate; Terpinyl-3-phenyl propenoate; (Z)-1-methyl-1-(4-methyl-3-cyclohexen-1-yl) ethyl cinnamate
T009	Terpinyl formate	α -Terpinyl formate; p-Menth-1-en-8-yl formate
T010	Terpinyl isobutyrate	Terpinyl 2-methylpropionate; p-Menth-1-en-8-yl isobutyrate; 1-Methyl-1-(4-methylcyclohex-3-enyl)ethyl 2-methylpropionate
T011	Terpinyl isovalerate	Isopentanoate; p-Menth-1-en-8-yl 3-methylbutanoate; p-Menth-1-en-8-yl isopentanoate; Terpinyl isopentanoate; p-Menth-1-en-8-yl 3-methylbutyrate; p-Menth-1-en-8-yl isovalerate; p-Menth-1-en-8-yl- β -methylbutyrate; terpinyl isovalerianate
T012	Terpinyl propionate	Menthen-1-yl-8-ate; p-Menth-1-en-8-ol propionate; p-Menth-1-en-8-yl propanoate; p-Menth-1-en-8-yl propionate; p-Menthanyl propionate (mixed isomers)
T013	Tetradec-2-enal	
T014	delta-Tetradecalactone	4-Tetradecanolide; 6-Nonyltetrahydro-2-pyrone; Tetradeca-1,5-lactone; Tetradecano- 1,5-lactone; 5-Hydroxytetradecanoic acid lactone; 2H-pyran-2-one, tetrahydro-6-nonyl-
T015	(Z)-8-Tetradecenal	(Z)-Tetradec-8-enal
T016	Tetrahydro-4-methyl-2-(2-methylpropen-1-yl)pyran	Menthofuran (tetrahydro-4-methyl-2-(2-methyl-1-p); 2-(2-Methylprop-1-enyl)-4-methyltetrahydropyran; Tetrahydro-4-methyl-2-(2-methyl-1-propenyl)-(2H)pyran; Rosenoxid inaktiv(Dragon); Rose oxide; Tetrahydro-4-methyl-2-(2-methylpropen-1-yl)pyran

Order	General Name	Synonyms
T017	1,2,5,6-Tetrahydrocuminic acid	3-Cyclohexene-1-carboxylic acid, 4-(1-methylethyl)-,(±); 4-isopropyl-3-cyclohexene-1-carboxylic acid; 4-(1-Methylethyl)-3-cyclohexene-1-carboxylic acid; 1-(4-Isopropylcyclohex-3-enyl)carboxylic acid
T018	Tetrahydrofurfuryl acetate	Tetrahydro-2-furyl methylacetate
T019	Tetrahydrofurfuryl alcohol	Tetrahydro-2-furancarbinol; Tetrahydro-2-furanmethanol; Tetrahydro-2-furylmethanol
T020	Tetrahydrofurfuryl butyrate	Tetrahydrofurfuryl- <i>n</i> -butyrate; Tetrahydro-2-furylmethyl- <i>n</i> -butanoate
T021	Tetrahydrofurfuryl cinnamate	Tetrahydrofurfuryl 3-phenylpropenoate; Tetrahydro-2-furylmethyl 3-phenylpropenoate; tetrahydro-2-furylmethyl cinnamate; Cinnamic acid, tetrahydrofurfuryl ester
T022	Tetrahydrofurfuryl propionate	Tetrahydrofurfuryl propanoate; 2-Tetrahydrofurfurylmethyl propionate; Tetrahydro-2-furylmethylpropionate
T023	Tetrahydrolinalool	3,7-Dimethyloctan-3-ol; 3,7-dimethyloctanol-3; Tetrahydrolinalool; Tetrahydrolinalol; 1-Ethyl-1,5-dimethyl hexanol
T024	3,4,5,6-Tetrahydropseudoionone	Tetrahydro-pseudo-ionone; Tetrameran (IFF); Dihydrogeranyl acetone; 6,10-Dimethyl- 9-undecen-2-one; 6,10-Dimethylundec-9-en-2-one
T025	Tetrahydro-pseudo-ionone	6,10-Dimethyl-9-undecen-2-one
T026	5,6,7,8-Tetrahydroquinoxaline	Cyclohexapyrazine; tetrahydroquinoxaline

Order	General Name	Synonyms
T027	Tetramethyl ethylcyclohexenone (mixture of isomers)	Mixture of 5-ethyl-2,3,4,5-tetramethyl-2-cyclohexen-1-one and 5-ethyl-3,4,5,6- tetramethyl-2-cyclohexen-1-one
T028	1,5,5,9-Tetramethyl-13-oxatricyclo(8.3.0.0(4,9))tridecane	Ambroxan; ambrox; Dodecahydro-3a,6,6,9a-tetramethylnaphtho (2,1-b) furan; Dodecahydro-3a,6,6,9a-tetramethylnaphtho (2,1-b)furan; Tetramethyl- perhydronaphthofuran
T029	2,3,5,6-Tetramethylpyrazine	Tetramethylpyrazine; Tetramethyl-1,4-diazine
T030	Theaspirane	Spirooxide; 1-Oxaspiro[4,5]dec-6-ene, 2,6,10,10-tetramethyl-; 1-Oxaspiro-2,6,10,10- tetra-methyl[4,5]dec-6-ene; 2,6,10,10-tetramethyl-1-oxaspiro(4,5)dec-6-ene
T031	Thiamine hydrochloride	Vitamin b1 hydrochloride; 3-((4-Amino-2-methyl-5-pyrimidinyl)methyl)-5-(2- hydroxy- ethyl)-4-methylthiazolium chloride, Aneurine hydrochoride; Thiamine; Vitamin B1
T032	Thiazole	
T033	2-Thienyl disulfide	2,2'-Dithiodithiophene; 2,2- α -Dithiodithiophene
T034	2-Thienylmercaptan	2-Mercaptothiophene; 2-thienylthiol; thiophene-2-thiol; 2-Thionyl mercaptan; 2-Thiophenethiol
T035	Thioacetic acid	Ethanethioic acid; Thiolacetic acid; Acetothioic acid
T036	2,2'-(Thiodimethylene)difuran	Difurfuryl monosulfide; 2-Furfuryl monosulfide; Difurfuryl sulfide; bis(2-furfuryl)sulfide; 2-Furfuryl monosulfide; 2,2'- (Thiodimethylene)-difuran; 2-Furfuryl monosulphide; Difurfuryl monosulphide;

Order	General Name	Synonyms
T037	Thiogeraniol	3,7-Dimethyl-2(trans),6-octadien-1-thiol, 3,7-Dimethyl-2,6-octadien-1-yl mercaptan; 3,7-Dimethyl-2,6-octadien-1-thiol; 2,6-octadiene-1-thiol, 3,7-dimethyl-,(E)-
T038	4-Thujanol	Sabina hydrate; Sabinene hydrate; 2-Methyl-5-(1-methylethyl)bicyclo[3.1.0]hexan-2-ol; Thujan-4-ol
T039	Thujyl alcohol	Bicyclo[3.1.0]hexan-3-ol, 4-methyl-1-(1-methylethyl)-, (1S,3S,4R,5R)-; 3-Thujanol, (1S,3S,4R,5R)-(-)-; Bicyclo[3.1.0]hexan-3-ol, 4-methyl-1-(1-methylethyl)-, [1S-(1.α., 3.α.,4.α.,5.α)]-; (-)-3-neoisothujanol; (-)-Thujol; 3-neoisothujanol, (-)-; thijol, (-)-
T040	Thymol	5-Methyl-2-isopropylphenol; 2-Isopropyl-5-methylphenol; α-Cymophenol; 6-isopropyl-m-cresol; 5-Methyl-2(1-methylethyl)phenol; 3-p-Cymenol; 3-Hydroxy-p-cymene; p-Isopropyl-m-cresol; 1-Methyl-3-hydroxy-4-isopropylbenzene; 3-Methyl-6-isopropylphenol; Thyme camphor; m-Thymol
T041	Tolualdehyde glyceryl acetal	2-(<i>o,m,p</i> -Cresyl)-5-hydroxydoixan; 2-(<i>o,m,p</i> -cresyl)-5-hydroxymethyldioxolan; 2-(methylphenyl)-1,3-dioxan-5-ol, mixed <i>o,m,p</i> - tolyl glycerin; 2-(2,3 and 4-methylphenyl)-5-hydroxy-1,3-dioxane and 2-(2,3 and 4-methylphenyl)-5-phdroxymethyl-1,3-dioxolane (mixture), Tolyly glycerin; 2-(<i>o,m,p</i> -cresyl)-5-hydroxy dioxane and 2-(<i>o,m,p</i> -cresyl)-5-hydroxymethyldioxolane mixture; 2-(<i>o,m,p</i> -cresyl)- 4-hydroxymethyldioxolane; 2-5-hydroxymethyldioxolane
T042	Tolualdehydes (mixed o,m,p)	Mixture of <i>o</i> -methylbenzaldehyde and <i>m</i> -methylbenzaldehyde and <i>p</i> -methylbenzaldehyde, Toluic aldehyde (mixed <i>o,m,p</i>); Tolyly aldehyde (mixed <i>o,m,p</i>); methylbenzaldehyde(mixed 2,3,4); Toluic aldehyde(mixed 2,3,4)
T043	<i>o</i> -Toluenethiol	2-Methylthiophenol; <i>o</i> -tolylmercaptan; 2-Methylbenzene-1-thiol; 2-Methylbenzenethiol
T044	2-(<i>p</i> -Toly)propionaldehyde	<i>p</i> -methyl-α-Methylphenylacetaldehyde; <i>p</i> -Methylhydratropaldehyde
T045	<i>p</i> -Tolyly 3-methylbutyrate	<i>p</i> -Tolyly isovalerate; <i>p</i> -cresyl 3-methylbutanoate; <i>p</i> -Methylphenyl 3-methylbutyrate; 4-Methylphenyl isovalerate; <i>p</i> -Cresyl isovalerate; <i>p</i> -Tolyly isovalerate; <i>p</i> -Cresyl isopentanoate; 4-Methylphenyl 3-methylbutyrate

Order	General Name	Synonyms
T046	o-Tolyl acetate	2-Methylphenyl acetate; o-Cresol acetate; Acetyl o-cresol; o-Cresyl acetate; α -Cresylic acetate
T047	p-Tolyl acetate	p-Cresylic acetate; p-tolyl ethanoate; Acetyl-p-cresol; p-cresyl acetate; p-methylphenyl acetate; cresyl acetate para(Givaudan Roure); p-Cresyl acetate; 4-methylbenzoic acid methyl ester; Acetyl p-Cresol
T048	p-Tolyl isobutyrate	p-Tolyl 2-methylpropanoate; p-Methylphenyl isobutyrate; p-Methylphenyl 2-methylpropanoate; p-Cresyl isobutyrate
T049	o-Tolyl isobutyrate	<i>o</i> -Cresyl isobutyrate; 2-Methylphenyl 2-methylpropanoate; Propanoic acid, 2-Methyl-, 2-methylphenyl ester; 0-Tolyl 2-methylpropanoate
T050	p-Tolyl laurate	p-Methylphenyl dodecanoate; p-Cresyl dodecanoate; p-Cresyl laurate; p-Tolyl dodecanoate; p-Tolyl dodecylate
T051	p-Tolyl octanoate	<i>p</i> -Cresyl caprylate; <i>p</i> -Cresyl octanoate; <i>p</i> -Methylphenyl octanoate; Octanoic acid, 4-methylphenyl ester, <i>p</i> -Tolyl caprylate
T052	p-Tolyl phenylacetate	p-Methylphenyl phenylacetate; narcissin; p-Cresyl phenylacetate; p-tolyl α -toluate; p-Cresyl α -toluate; p-Methylphenyl α -toluate
T053	o-Tolyl salicylate	Benzoic acid, 2-hydroxy-, 2-methylphenyl ester, <i>o</i> -cesyl salicylate; 2-Methylphenyl 2-hydroxybenzoate
T054	4-(p-Tolyl)-2-butanone	<i>p</i> -Methylbenzylacetone; 4-(4-Methylphenyl)-2-butanone
T055	p-Tolylacetaldehyde	<i>p</i> -Methyl phenylacetaldehyde; Syringa aldehyde; (4-Methylphenyl)acetaldehyde
T056	Tributyl acetylcitrate	Acetyl tributylcitrate; Tributyl 2-acetox-1,2,3-propanetricarboxylate

Order	General Name	Synonyms
T057	Tributylin	Glyceryl tributurate; butylin; 1,2,3-tri(butyryloxy)propane; Tributyrin
T058	2-Tridecanone	Tridecan-2-one; Hendecyl methyl ketone; methyl undecyl ketone
T059	2-trans-4-cis-7-cis-Tridecatrienal	Trideca-2(trans),4(cis),7(cis)-trienal; 2,4,7-Tridecatrienal, (E,Z,Z)-; Trideca-2,4,7-trienal
T060	2-Tridecenal	
T061	trans-2-Tridecenal	3-Decylacrolein; Tridec-2-enal; aldehyde C-13
T062	Triethyl citrate	Citric acid, triethyl ester; Ethyl citrate; 1,2,3-Propanetricarboxylic acid, 2-hydroxy-, triethyl ester; Triethyl 2-hydroxy-1,2,3-propane-tricarboxylate
T063	Triethylamine	Triethylamine; (Diethylamino)ethane; N,N-Diethylethanamine
T064	2,4,6-Triisobutyl-5,6-dihydro-4H-1,3,5-dithiazine	4H-1,3,5-Dithiazine, dihydro-2,4,6-tri(2-methylpropyl)-; Dihydro-2,4,6-triisobutyl-4h- 1,3,5-dithiazine

Order	General Name	Synonyms
T065	3,3,5-Trimethyl cyclohexanol	Cyclonol; Homomenthol; 1-Methyl-3,3-dimethyl cyclohexan-5-ol; 3,3,5- Trimethylcyclohexan-1-ol
T066	2,6,6-Trimethyl-1&2-cyclohexen-1-carboxaldehyde	α,β -Cylclocitral (mixture); 2,6,6- Trimethylcyclohex-2-ene-1-carboxaldehyde; β - Cyclocitral
T067	2,2,4-Trimethyl-1,3-dioxacyclopentane	Acetone propylene glycol acetal; 2,2,4-Trimethyl-1,3-dioxolane; propylene glycol acetone ketal; Acetone propylene glycol ketal
T068	2,6,6-Trimethyl-1-cyclohexen-1-acetaldehyde	β -Homocyclocitral; 2,6,6- Trimethylcyclohex-1-en-1-acetaldehyde
T069	2,6,6-Trimethyl-1-cyclohexen-1-carboxaldehyde	2,6,6-Trimethyl-1 or 2-cyclohexen-1-carboxaldehyde; 2,6,6-Trimethyl-2-cyclohexene-1- carboxaldehyde; β -cyclocitral; cyclocitral
T070	3,5,5-Trimethyl-1-hexanol	3,5,5,-trimethylhexanol; Isononanol; Isononyl alcohol; tert-butyl isopentanol; Trimethyl hexyl alcohol
T071	2,6,10-Trimethyl-2,6,10-pentadecatrien-14-one	6,10,14-Trimethylpentadeca-5,9,13-trien-2-one; 6,10,14-Trimethyl-5,9,13- penta- decatrien-2-one; farnesyl acetone; 2,6,10-Trimethyl-2,6,10- pentadecatrien- 14-one
T072	3,7,11-Trimethyl-2,6-10-dodecatrienal	3,7,11-Trimethyl dodecatrien-2,6,10-al-1; Farnesal
T073	cis-1-(2,6,6-Trimethyl-2-cyclohexen-1-yl)but-2-en-1-one	cis- α -Damascone
T074	(+/-)-(2,6,6-Trimethyl-2-hydroxycyclohexylidene)acetic acid γ -lactone	(+/-)Dihydroactinidiolide-5,6,7,7 α -Tetrahydro-4,4,7 α -trimethyl-2(4H)benzofuranone
T075	1,3,3-Trimethyl-2-norbornanyl acetate	Fenchyl acetate; Fenchyl acetate

Order	General Name	Synonyms
T076	2,6,6-Trimethyl-2-vinyltetrahydropyran	Bois de rose oxide; 2H-pyran, 2-ethenyltetrahydro-2,6,6-trimethyl-; Trimethyl-2,2,6- vinyl-6-tetrahydropyran
T077	trans- and cis-2,4,8-Trimethyl-3,7-nonadien-2-ol	3,7-Nonadien-2-ol, 2,4,8-trimethyl- (2E,4Z)-; Cranberry extra
T078	2,3,4-Trimethyl-3-pentanol	Diisopropyl methyl carbinol
T079	(+/-)-2,4,8-Trimethyl-7-nonen-2-ol	7-Nonen-2-ol, 2,4,8-trimethyl-
T080	Trimethylamine	N,N-Dimethylmethylamine
T081	p- α , α -Trimethylbenzyl alcohol	2-p-Tolyl-2-propanol; 2-(4-Methylphenyl)-2-propanol; 8-Hydroxy-p-cymene; 2-(4-Methylphenyl)propan-2-ol; p-Cymen-8-ol; Dimethyl-p-tolylcarbinol; 2-(4- Methylphenyl)propan-2-ol
T082	2,6,6-Trimethylcyclohex-2-ene-1,4-dione	3,5,5-Trimethyl-2-cyclohexene-1,4-dione; 2-Cyclohexenedione-1,4,3,5,5-trimethyl-
T083	2,6,6-Trimethylcyclohexa-1,3-dienyl methanal	2,2,6-Trimethyl-1,3-cyclohexadien-1-carboxaldehyde; 2,2,6-trimethyl-4,6- cyclohexadien-1-carboxaldehyde; 1,1,3-Trimethyl-2-formylcyclohexa-2,4-diene; Dehydro β -cyclocitral; safranal; 2,6,6-Trimethylcyclohexa-1,3-diene-1-carbaldehyde; 2,3-Dihydro-2,2,6-trimethylbenzaldehyde; 2,6,6-Trimethyl-1,3-cyclohexadenal
T084	2,2,6-Trimethylcyclohexanone	Cyclohexanone, 2,2,6-trimethyl-
T085	2,2,3-Trimethylcyclopent-3-en-1-yl acetaldehyde	Acetaldehyde, (2,2,3-trimethylcyclopent-3-en-1-yl); Campholenic aldehyde; (R)-2,2,3-trimethylcyclopent-3-ene-1-acetaldehyde; α -Campholenic aldehyde; (2,3,3-Trimethylcyclopent-3-en-1-yl-2)acetaldehyde
T086	2,4,5-Trimethyl-delta-3-oxazoline	2,4,5-Trimethyl-3-oxazoline; Oxazole, 2,5-dihydro-2,4,5-trimethyl-; 2,4,5-Trimethyl-2,5- dihydrooxazole; 3-Oxazoline, 2,4,5-trimethyl
T087	2,4,6-Trimethyldihydro-4H-1,3,5-dithiazine	4H-1,3,5-dithiazine, dihydro-2,4,6-trimethyl-(2 α , 4 α , 6 α)-; 2,4,6-Trimethyldihydro-1,3,5-dithiazine; 2,4,6-Trimethylperhydro-1,3-dithiazine; 2,6-Dihydro-2,4,6-trimethyl-1,3,5-dithiazine; Dihydro-2,4,6-trimethyl-1,3,5(4H)dithiazine; Dihydro-2,4,6-trimethyl-4h-1,3,5-dithiazine, Thialdine
T088	3,7,11-Trimethyldodeca-2,6,10-trienyl acetate	Farnesol acetate; Farnesyl acetate

Order	General Name	Synonyms
T089	3,5,5-Trimethylhexanal	Verdinal; Hexanal, 3,5,5-trimethyl; Vandor B; Isononylaldehyde; Tert-Butylisopentanal
T090	Trimethylamine oxide	Trimethylamine, N-oxide; N,N-Dimethylmethanamine N-oxide
T091	2,3,6-Trimethylphenol	3-Hydroxypseudocumene; Methyl xlenol-2,3,6; 3-Hydroxypseudocumene
T092	2,3,5-Trimethylpyrazine	Trimethylpyrazine; 2,3,5-Trimethyl-1,4-diazine
T093	2,4,5-Trimethylthiazole	
T094	Tripropylamine	N,N-Dipropyl-1-propanamine; Propyl-di-n-propylamine; Tri-n-propylamine
T095	1,2,3-Tris([1'-ethoxy]-ethoxy)propane	3,5,9,11-Tetraoxatridecane, 7-(1-ethoxyethoxy)-4,10-dimethyl-; Acetaldehyde ethyl glyceryl mixed acetal
T096	2,4,6-Trithiaheptane	bis-(Methylthiomethyl)sulfi de
T097	2,3,5-Trithiahexane	Methyl(methylthio)methyl disulfide; (Methyldithio) (methylthio)methane; 2,4,5- Trithiahexane
T098	Trithioacetone	2,2,4,4,6,6-Hexamethyl-s-trithiane; 2,2,4,4,6,6-Hexanethyl-5-trithiane; 1,3,5-trithiane, 2,2,4,4,6,6-hexamethyl-; 2,2,4,4,6,6-Hexamethyl-1,3,5-trithiane
T099	Tuberoso lactone	2(3H)-Furanone, dihydro-5-(2,5-octadienyl)-; (Z,Z)-6,9-Dodecadien-4-olide, (z,z)-
T100	Tyramine	4-(2-Aminoethyl)phenol; 2-(4-Hydroxyphenyl) ethylamine; Systogene; Tocosine; Uteramine; Tyrosamine; p-β-Aminoethylphenol; 4-Hydroxyphenylethylamine; 4-Hydroxyphenethylamine; p-Hydroxyphenylethylamine; p-Hydroxyphenethylamine; Benzeneethanamine

Order	General Name	Synonyms
T101	Thiophene-2-carbaldehyde	α -Formylthiophene; α -Thiophenecarboxaldehyde; 2-Formylthiophene; 2-Thienylaldehyde; 2-Thienylcarboxaldehyde; 2-Thiophenealdehyde; Thiophene-2-carboxaldehyde; Thiophene-2-aldehyde; 2-Thiophenecarbaldehyde; 2-Thiophenaldehyde; 2-thiophencarboxaldehyde; 2-thiophene carboxyaldehyde; 2-thiophenic aldehyde; thiophen-2-carboxaldehyde; 2-Carboxaldehyde-thiophene; 2-Thiophenecarboxaldehyde
T102	2,4,6-Trimethylpyridine	α,γ,α' -Collidine; γ -Collidine; s-Collidine; 2,4,6-Collidine; sym-Collidine; 2,4,6-Kollidin; a,g,a'-Collidine; g-Collidine; Collidine; Pyridine, 2,4,6-trimethyl-
T103	Tetrahydrothiophene	Tetramethylene sulfide; Thiacyclopentane; Thilane; Thiolane; Thiophane; Tetramethylene sulphide; Thiolan Tetrahydrothiofen; Thiofan; Tetrahydrothiophen; Thiophene, tetrahydro-
T104	Thiophene	Thiacyclopentadiene; Thiofuram; Thiofuran; Thiofurfuran; Thiole; Thiotetrole; Divinylene sulfide; Furan, Thio-; Thiaphene; Thiofen
T105	Tetradecan-1-ol	n-Tetradecan-1-ol; n-Tetradecanol; n-Tetradecyl alcohol; Myristic alcohol; Myristyl alcohol; Tetradecyl alcohol; n-Tetradecanol-1; 1-Hydroxytetradecane; Myristyl alcohol; Tetradecanol-1; Tetradecanol; 1-Tetradecanol
T106	Triethoxymethane	Ethane, 1,1',1''-[methylidynetris(oxy)]tris-; Orthoformic acid, triethyl ester; Aethon; Ethone; Orthoformic acid ethyl ester; Triethyl orthoformate; Ethyl formate(ortho); 1-(Diethoxymethoxy)ethane; Triethoxmethane; Methane, triethoxy-; 1,1',1''-(Methylidynetris(oxy))tris(ethane); Triethyl ester of Orthoformic acid; Ethyl orthoformate
T107	1,2,4-Trithiolane	
T108	1,2,4,5-Tetrathiane	s-Tetrathiane; 1,2,4,5-Tetrathiacyclohexane

Order	General Name	Synonyms
T109	6,10,14-Trimethylpentadecan-2-one	Hexahydrofarnesyl acetone; 6,10,14-Trimethyl-2-pentadecanone; 6,10,14-Trimethylpentadecan-2-one (hexahydrofarnesylacetone); 6,10,14-trimethylpentadecanone;2-Pentadecanone, 6,10,14-trimethyl-
T110	1,7,7-Trimethyltricyclo[2.2.1.0.(2.6)]heptane	Tricyclo[2.2.1.0(2,6)]heptane, 1,7,7-trimethyl-; Tricyclene; 1,7,7-Trimethyltricyclo[2.2.1.0(sup2,6)]heptane; α -Tricyclene; 1,7,7-Trimethyl-tricyclo[2.2.1.0*2,6*]heptane;Tricyclo[2.2.1.02,6]heptane, 1,7,7-trimethyl-
T111	2,4,6-Trimethylphenol	Mesitol; 1-Hydroxy-2,4,6-trimethylbenzene; 2-Hydroxymesitylene;Mesityl alcohol;2,4,6-Trimetylofenol;Phenol, 2,4,6-trimethyl-
T112	3,3,6-Trimethylhepta-1,5-dien-4-one	1,5-Heptadien-4-one, 3,3,6-trimethyl-; Isoartemesia ketone; 2,5,5-Trimethyl-2,6-heptadien-4-one; Artemesia; Hepta-1,5-dien-4-one, 3,3,6-trimethyl;Artemesia ketone;3,3,6-Trimethyl-1,5-heptadien-4-one
T113	Tetradecane	n-Tetradecane
T114	1,2,3-Trimethoxybenzene	Methylsyringol; Pyrogallol trimethyl ether; Tri-O-methylpyrogallol; Benzene, 1,2,3-trimethoxy-
T115	Tridecanoic acid	n-Tridecanoic acid; n-Tridecoic acid; Tridecylic acid
T116	3,3,5-Trimethylcyclohexan-1-one	Dihydroisophorone; 3,5,5-Triethylcyclohexanone; 3,3,5-trimethyl-cyclohexanone;Cyclohexanone, 3,3,5-trimethyl-;3,3,5-Trimethylcyclohexanone
T117	Tetradecan-2-one	2-Tetradecanone
T118	1,1,3-Triethoxypropane	β -Ethoxypropionaldehyde diethyl acetal; 3-Ethoxypropionaldehyde diethyl acetal; Propionaldehyde, 3-ethoxy-, diethyl acetal; Propane, 1,3,3-triethoxy-; 1,3,3-Triethoxypropane;Propane, 1,1,3-triethoxy-
T119	Tridecanal	n-Tridecylaldehyde; Tridecanaldehyde; Tridecyl aldehyde; 1-Tridecanal; Tridecane aldehyde; n-Tridecanal

Order	General Name	Synonyms
T120	α -Terpinyl methyl ether	
T121	1,1'-(Tetrahydro-6a-hydroxy-2,3a,5-trimethylfuro[2,3-d]-1,3-dioxole-2,5-diyl)bis-ethanone	Diacetyl trimer;Furo[2,3-d]-1,3-dioxol-6a(3aH)-ol, 2,5-diacetyldihydro-2,3a,5-trimethyl-; Furo[2,3-d]-1,3-dioxole, ethanone derivative 2,3-Butanedione trimer; 2,5-Diacetyl-3a,5,6,6a-tetrahydro-6a-hydroxy-2,3a,5-trimethylfuro[2,3-d]-1,3-dioxole; Biacetyl trimer
T122	2,6,6-Trimethylcyclohex-2-en-1-one	2,6,6-trimethyl-2-cyclohexenone; 2,6,6-Trimethylcyclohex-2-enone; 2-Cyclohexen-1-one, 2,6,6-trimethyl-; 5-Cyclohexen-1-one, 2,2,6-trimethyl;2,6,6-Trimethyl-2-cyclohexen-1-one
T123	Trimethyloxazole	2,4,5-Trimethyloxazole; 2,4,5-Trimethyl-1,3-oxazole; Oxazole, 2,4,5-trimethyl;Oxazole, trimethyl-
T124	4-(2,3,6-Trimethylphenyl)but-3-en-2-one	
T125	[S-(cis)]-3,7,11-Trimethyl-1,6,10-dodecatrien-3-ol	1,6,10-Dodecatrien-3-ol, 3,7,11-trimethyl-, (Z)-(S)-(+)-; (+)-Nerolidol; D-nerolidol; Nerolidol; Nerolidol, cis-(+)-; Peruviol; 3,7,11-Trimethyl-1,6,10-dodecatriene-3-ol, Z-; (6Z)-3,7,11-Trimethyl-1,6,10-dodecatrien-3-ol; (Z)-Nerolidol;1,6,10-Dodecatrien-3-ol, 3,7,11-trimethyl-, [S-(Z)]-
T126	trans-2-Tridecenol	(E)-2-Tridecenol; (E)-2-Tridecen-1-ol; (E)-Tridec-2-en-1-ol; trans-2-Tridecen-1-ol;
T127	Triethylthialdine	2,4,6-Triethyl-1,3,5-dithiazinane

Order	General Name	Synonyms
T128	3,3,5-Trimethylcyclohexyl acetate	Cyclohexanol, 3,3,5-trimethyl-, acetate; Homomenthol acetate; Homomenthyl acetate
T129	2,6,10-Trimethyl-9-undecenal	2,6,10-Trimethylundec-9-enal
U001	2,4-undecadienal	tr-2, tr-4-Undecadienal
U002	2,3-Undecadione	Acetyl nonanoyl; Acetyl nonyryl; Acetyl pelargonyl; Acetyl nonanyl
U003	γ -Undecalactone *	4-Undecanolide; 5-heptyldihydro-2(3H)-furanone; Aldehyde c-14 pure; undeca-1,4- lactone; γ -Undecyl lactone; 4-Hydroxyundecanoic acid, γ -lactone; 1,4-Hendecanolide; 4-n-heptyl-4-Hydroxybutanoic acid lactone; 4-Hydroxyundecanoic acid lactone; γ -n-Heptyl- γ -butyrolactone; Undecano-1,4-lactone; γ -Heptyl butyrolactone; 4-Hydroxyundecanoic acid, γ -lactone; Peach aldehyde; undecanolide- 1,4; aldehyde C?14; γ -Undecalactone; γ -Heptyl butyrolactone
U004	Undecanal	Aaldehyde C-11(saturated); hendecanal; α -Oxo-undecane; n-Undecylic aldehyde; Undecylenic; Undecylic aldehyde; Aldehyde C-11 undecylic; Undecanoic aldehyde; n-Undecylaldehyde; Undecan-1-al
U005	Undecanoic acid	n-Undecoic acid; n-Undecylic acid; Decane- α -carboxylic acid; Hendecanoic acid
U006	2-Undecanol	sec-Undecylic alcohol; Methyl nonyl carbinol; 2-Hendecanol; sec-Undecyl alcohol

Order	General Name	Synonyms
U007	2-Undecanone	2-Hendecanone; 2-oxoundecane; Nonyl methyl ketone; Rue ketone; Methyl nonyl ketone; Undecanone
U008	6-Undecanone	Undecan-6-one, Diamyl ketone; Dipentyl ketone
U009	1,3,5-Undecatriene	Undeca-1,3,5-triene; Galbanolene; Galbanolene super
U010	2-Undecen-1-ol	1-Hydroxy-2-undecene; trans-2-Undecenol
U011	Undecen-1-ol	Undecylenic alcohol
U012	10-Undecen-1-yl acetate	Acetate C-11; 10-hendecenyl acetate; Undecenyl acetate; Undecelynic acetate; Undec-10-enyl acetate
U013	9-Undecenal	Aldehyde C-11 undecylenic; Hendecen-9-al; Undecenoic aldehyde; Undecylenic aldehyde; 10-Hendecenal; 9-Undecylenic aldehyde
U014	10-Undecenal	Acetate C-11 undecylenic; Hendecenal; Undecylenic aldehyde; 10-Hendecenal; Undecylenic aldehyde (mixed isomers); Undecenal; Intreleven aldehyde; Aldehyde C-11
U015	2-Undecenal	2-Undecen-1-al; Undecen-2-al; 3-Octylacrolein
U016	Undecenal	
U017	10-Undecenoic acid	10-Hendecenoic acid; Undecylenic acid
U018	Undecyl alcohol	Alcohol C-11; Hendecanol; 1-Undecanol; Alcohol c-11 undecylic; Decyl carbinol; 1-Hendecanol; Undecan-1-ol
U019	Undecyl acetate	n-undecyl acetate; 1-Un

Order	General Name	Synonyms
U020	10-Undecen-2-one	undecenone
U021	Undecanal propylene glycol acetal	
U022	3,5-Undecadien-2-one	Undeca-3,5-dien-2-one
U023	(E)-4-Undecenal	(E)-Undec-4-enal; trans-Undec-4-enal; 4E-Undecenal
V001	Valencene	1,2,3,5,6,7,8,8a-Octahydro-1,8a-dimethyl-7-(1-methylethenyl)-naphthalene; 1,2,3,5,6,7,8a-Octahydro-1,8a-dimethyl-7-isopropenyl naphthalene
V002	Valeraldehyde	n-valeraldehyde; Pentanal; Amylaldehyde; n-Pentanal; Valeral; n-Valeric aldehyde; Valeric aldehyde; Pentan-1-al; Aldehyde c-5
V003	Valeric acid	Valerianic acid; Pentanoic acid; Propylacetic acid; 1-Butanecarboxylic acid
V004	γ -Valerolactone	4-pentanolide; 5-Methyldihydro-2(3H)-furanone; penta-1,4-lactone; 3-Valerolantone; 3-methylbutyrolactone; γ -Methyl- γ -butyrolactone; Pentano-1,4-lactone; 2(3H)-Furanone, dihydro-5-methyl-; 4-Hydroxypentanoic acid, γ -lactone; γ -Methyl- γ -butyrolactone; 4-Methyl-4-hydroxybutanoic acid lactone; Pentanolide-1,4; 4-Valerolactone; γ -valeryllactone; 4-Hydroxypentanoic acid lactone; γ -Pentalactone
V005	Vanillin *	Vanillic aldehyde; 3-methoxy-4-hydroxybenzaldehyde; Vanillaldehyde; 4-Hydroxy-3-methoxybenzaldehyde; methyl protocatechuic aldehyde; Protocatechualdehyde-3-methylether

Order	General Name	Synonyms
V006	Vanillin 3-(l-menthoxy)propane-1,2-diol acetal	4-(l-Menthoxymethyl)-2(3-methoxy-4-hydroxyphenyl)-1,3-dioxolane; 4-[2-(Methylethyl)-5-methylcyclohexyloxy]-2,5-dioxolanyl-2-methoxyphenol
V007	Vanillin erythro- and threo-butan-2,3-diol acetal	2-(4-Hydroxy-3-methoxyphenyl)-4,5-dimethyl-1,3-dioxolane, 4-(4,5-dimethyl-1,3-dioxolan-2-yl)-2-methoxyphenol
V008	Vanillin isobutyrate	Isobutavan; m-Anisaldehyde, 4-hydroxy, 2-methyl propionate; Benzaldehyde, 4-hydroxy, 3-methoxy, 2-methylpropanoate; 4-Formyl-2-methoxy-phenyl 2-methylpropanoate; isobutyric acid, ester with vanillin; 3-Methoxy-4- isobutyrylbenzaldehyde; Propanoic acid, 2-methyl, 4-formyl-2-methoxyphenyl ester; 4-Hydroxy-3-methoxybenzaldehyde; 4-Hydroxy-m-anisaldehyde 2-methyl propionate; anillyl isobutyrate; 4-Isobutyryl-m-anisaldehyde
V009	Vanillin propylene glycol acetal	2-(3-methoxy-4-hydroxyphenyl)-4-methyl-1,3-dioxolane; 2-Methoxy-4-(4-methyl-1,3-dioxolan-2-yl)phenol; 4-Methyl-2-(4-hydroxy-3-methoxyphenyl)-1,3-dioxolane
V010	Vanillyl acetate	Acetyl vanillin; 3-Methoxy-4-acetoxy benzaldehyde; 4-Acetoxy-3-methoxy- benzaldehyde; Benzaldehyde, 4-(acetyloxy)-3-methoxy-; Vanillin acetate
V011	Vanillyl alcohol	Benzenemethanol, 4-hydroxy-3-methoxy-; 4-Hydroxy-3-methoxybenzyl alcohol; 4-hydroxy-3-methoxyphenylmethanol
V012	Vanillyl butyl ether	4-(Butoxymethyl)-2-methoxyphenol; Phenol, 4-(butoxymethyl)-2-methoxy-; Butyl vanillyl ether; 2-methoxy-4-(butoxymethyl)phenol
V013	Vanillyl ethyl ether	4-(Ethoxymethyl)-2-methoxyphenol, Vee; Ethyl 4-hydroxy-3-methoxybenzyl ether
V014	Vanillylidene acetone	3-Buten-2-one, 4-(4-hydroxy-3-methoxyphenyl)-; 4-(4-Hydroxy-3-methoxyphenyl)but- 3-en-2-one; Methyl 3-methoxy-4-hydroxystyrl ketone; Dihydrozingerone
V015	Veratraldehyde	Dimethyl ether protocatechualdehyde; Veratric aldehyde; 3,4-Dimethoxybenzaldehyde; 3,4-Dimethoxybenzenecarbonal; Methyl vanillin; Protocatechualdehyde dimethylether; Vanillin methyl ether; O-Methyl vanillin; p-Veratric aldehyde

Order	General Name	Synonyms
V016	Verbenol	Bicyclo[3,1,1]hept-2-en-2-ol, 4,6,6-trimethyl-; 4-Hydroxy-2,6,6-trimethylbicyclo(3,1,1)- hept-2-ene; 2-Pinen-4-ol; <i>d</i> -Verbenol; Pin-2-en-4-ol; 2-Pinenol-4; 2-pinen-4-ol
V017	Verbenone	Pin-2-en-4-one; 4,6,6-Trimethyl-bicyclo[3.1.1]hept-3-en-2-one; Bicyclo[3.1.1]hept-3- en-2-one, 4,6,6-trimethyl-
V018	Vetiverol	Vetivenol; Vetiverol; Lignolia; Khusimol; Octahydro-7,7-dimethyl-8-methylene-1H, 3A, 6-methanoazulene-3-methanol; 6-Azulenol, 1,2,3,3a,4,5,6,8a-octahydro-4,8- dimethyl-2-(1-methylethylidene)-; Vetivol
V019	Vetiveryl acetate	Vetacetyl; Vetacetia; Acetivenol; 6-Azulenol, 1,2,3,3a,4,5,6,8a-octahydro-4,8- dimethyl-2-(1-methylethylidene)-, acetate; Vetiver acetate; Vetivert acetate
V020	o-Vinyl anisole	1-Methoxy-2-vinylbenzene; 2-Methoxystyrene; o-Methoxystyrene
V021	p-Vinylphenol	4-Vinylphenol; 4-Ethenylphenol; 4-Hydroxystyrene; phenol, 4-ethenyl-
V022	Viridiflorol	1H-Cycloprop[e]azulen-4-ol, decahydro-1,1,4,7-tetramethyl-, [1ar-(1α,4β,4aβ,7α,7aβ,7bα)]-; 1,1,4,7-Tetramethyldecahydro-1H-cyclopropa[e]azulen-4-ol;Viridiflorol
V023	Valeraldehyde dibutyl acetal	
V024	Valeraldehyde propylene glycol acetal	1,3-Dioxolane, 2-butyl-4-methyl-; 2-Butyl-4-methyl-1,3-dioxolane; 1,3-Dioxolane, 2-butyl-4-methyl, trans; 1,3-Dioxolane, 4-methyl-2-butyl;1,3-Dioxolane, 2-butyl-4-methyl, cis
X001	2,6-Xylenol	2-Hydroxy-1,3-dimethylbenzene; 2,6-Dimethylphenol
X002	2,5-Xylenol	2,5-Dimethylpheno, 1-hydroxy-2,5-dimethylbenzene; phenol, 2,5-dimethyl-; 2,5- Dimethylphenol

Order	General Name	Synonyms
X003	3,4-Xylenol	3,4-Dimethylphenol; 1-Hydroxy-3,4-dimethylbenzene; Phenol, 3,4-dimethyl-
Y001	Yuzunone	(8E)-6,8,10-Undecatrien-3-one; trans/cis,trans-6,8,10-Undecatrien-3-one
Z001	Zingerone	4-(4-Hydroxy-3-methoxyphenyl)-2-butanone; 2-(4-Hydroxy-3-methoxyphenyl) ethyl methyl ketone; 4-Hydroxy-3-methoxy benzylacetone; (4-Hydroxy-3-methoxy- phenylethyl)methyl ketone; 3-Methoxy-4-hydroxy benzylacetone; 4-(3-Methoxy- 4-hydroxyphenyl)-2-butanone; Vanillyl acetone; 2-Ethyl methyl ketone; 3-Methoxy-4-methoxybenzylacetone

Order	General Name	Synonyms

* These synthetic flavoring substances shall be in accordance with their individual standards and specifications, as they are listed in II.4. Specification of Food Additives.

Boiler Water Additives

No.	Food additives
1	Ammonium alginate
2	Ammonium hydroxide
3	Disodium dihydrogen pyrophosphate
4	Disodium ethylenediaminetetraacetate
5	Erythorbic acid
6	Food starch modified
7	Magnesium sulfite
8	Phosphoric acid
9	Polyethylene glycol
10	Polysorbate 20
11	Polysorbate 60
12	Potassium alginate
13	Potassium carbonate
14	Potassium hydroxide
15	Potassium phosphate, dibasic
16	Potassium phosphate, monobasic
17	Potassium phosphate, tribasic
18	Potassium tripolyphosphate
19	Silicon dioxide
20	Sodium acetate
21	Sodium alginate
22	Sodium bicarbonate
23	Sodium bisulfite

No.	Food additives
24	Sodium carbonate
25	Sodium carboxymethyl cellulose
26	Sodium erythorbate
27	Sodium hydroxide
28	Sodium metabisulfite
29	Sodium metaphosphate
30	Sodium nitrate
31	Sodium phosphate, monobasic
32	Sodium phosphate, tribasic
33	Sodium polyacrylate
34	Sodium polyphosphates; Pentasodium triphosphate; Sodium tripolyphosphate
35	Sodium pyrophosphate
36	Sodium sulfate
37	Sodium sulfite
38	Sorbitan esters of fatty acids
39	Tannic acid
40	Trisodium citrate

Definition Food additives allowed to use as Boiler Water Additives purpose are shown below table. The food additives listed in II.4. Standards and Specifications must be suitable for those each standard and specification. However, the Boiler Water Additives contain the following food additives in a simple mixture of two or more food additives by a method that does not cause any chemical changes, and water or glucose could be added for the purpose of quality preservation, dilution and etc.

B. Mixed Preparations

L-Sodium Glutamate preparations

Definition L-Sodium Glutamate preparations should contain not less than 50.0% of L-sodium glutamate (as a major component) and other synthetic food additives. Or it can be mixed and diluted with one or more of spices (powder, juice, or extract), sodium chloride (salt), starch, glucose, sugar, or dextrin and used as a flavoring (soups are excluded). The specifications still apply even though the content of L-sodium glutamate is not more than 50.0% if only sodium chloride (salt) and hexane are mixed for dilution.

Compositional Specifications of Ingredient Containing L-Sodium Glutamate preparations

Content L-Sodium Glutamate preparations should contain not less than 90.0% of the labeled L-sodium glutamate content.

Description L-Sodium Glutamate preparations is powder, crystallite, or granule with its characteristic colorful gloss.

Identification An aqueous solution containing 0.1% of L-sodium glutamate preparations(if necessary, filtered) should have the same red spot as the standard, when thin layer chromatography is carried out under the following conditions.

Conditions for Thin Layer Chromatography

-Developing Solvent : n-butyl alcohol : glacial acetic acid : water (2 : 1 : 1)

-Thin Layer Plate : Silica gel

-Developing Distance : 10~15 cm

-Colorizing Agent : 0.2 g of ninhydrine is dissolved in n-butyl alcohol (saturated with water) to make 100 mL.

Purity (1) Arsenic : Proceed as directed under in Purity (1) for Mixed Preparations.

(2) Lead : Proceed as directed under in Purity (2) for Mixed Preparations.

Assay (L-Sodium Glutamate preparations)

(1) Apparatus

Amino acid analyzer or its equivalent

(2) Preparation of Test Solution : 0.2g of sample is taken. Add Lithium citrate buffer solution(pH 2.2) to make 100mL. 1mL of the solution is taken and diluted to 50mL. It is Test Solution. Test as following below procedure.

(3) Operation Condition

1) The measuring condition of amino acid analyzer

Column : HR Na Column (4.6mm × 200mm) or its equivalent

Column Temperature : 78°C

Detector and Wave : Absorbance (570nm)

Mobile Phase and Flow Rate:

- Buffer Solution : Lithium citrate buffer(pH 2.8) is flowed to the speed of 20mL/h
- Reaction Solution : Ninhydrin TS is flowed to the speed of 25mL/h
- Reactor Temperature : 135°C
- Injection Amount : 40 μ l

(4) Test Solution

- 1) Buffer Solution : Lithium citrate buffer(pH 2.8)
- 2) Ninhydrin Solution : 18 g of Ninhydrin and 0.7g of hydrindantin are precisely weighed and dissolved in 675 mL of dimethylsulfoxide. 225 mL of acetic lithium solution (pH 5.2) is added to the above solution.
- 3) Standard Stock Solution : 0.2g of Standard L-sodium glutamate is taken. Add Lithium citrate buffer solution(pH 2.2) to make 100mL volume.
- 4) Standard Solution : 1mL of Standard Stock Solution is taken. Add Lithium citrate buffer solution(pH 2.2) to make 50mL volume.

Alkali Additives for Noodles Preparations

Definition Alkali Additives for Noodles contains one or more of sodium salts or potassium salts such as sodium carbonate, potassium carbonate, sodium hydrogencarbonate, and phosphates. There are solid alkali additives for noodles preparations, liquid additives for noodles preparations, and diluted/powdered additives for noodles preparations(diluted with wheat flour or insoluble starch).

A. Compositional Specifications of Solid Alkali Additives for Noodles preparations

Description Solid Alkali Additives for Noodles preparations is colorless ~ white powder, crystalline lump, or their mixture.

Identification (1) An aqueous solution (1→10) of Solid Alkali Additives for Noodles preparations shows reactions of alkali.

(2) An aqueous solution (1→10) of Solid Alkali Additives for Noodles preparations shows reactions of Potassium Salts(A) or Sodium Salts(B) in Identification.

(3) An aqueous solution (1→10) of Solid Alkali Additives for Noodles preparations containing carbonates or hydrogen carbonates shows reactions of Carbonates(A) in Identification.

(4) An aqueous solution (1→10) of Solid Alkali Additives for Noodles preparations containing phosphates is acidified with diluted nitric acid. It shows reactions of Phosphates(B) in Identification.

Purity (1) Clarity of Solution : 200 mL aqueous solution containing 10 g of Solid Alkali Additives for Noodles preparations is colorless and slightly turbid or better.

(2) Alkali Metal Hydroxide : 10 g of Solid Alkali Additives for Noodles preparations is dissolved in water so that the total volume is 200 mL (Solution A). 50 mL of barium chloride solution and water are added to 40 mL of Solution A to bring the total volume to 100 mL. It is then shaken vigorously and filtered. When 3 drops of 0.1 N hydrochloric acid and 2 drops of phenolphthalein TS are added to 50 mL of the filtrate, it should not become red.

(3) Silicate Salts : 1 drop of phenolphthalein TS is added to 10 mL of Solution A in (2), where diluted hydrochloric acid is added until red color disappears. It is then heated for 15 minutes in a water bath and cooled. If the solution becomes red, diluted hydrochloric acid is added until the red color disappears. 1 drop of methylene blue TS and 10 mL of saturated ammonium chloride solution are added to the resulting solution, which is allowed to stand for 2 hours. This solution should not yield colored precipitates or turbidity with color.

(4) Chlorides : 1 mL of Solution A in (2) proceed as directed under chlorides. The content should not be more than the amount that corresponds to 0.5 mL of 0.01 N hydrochloric acid.

(5) Arsenic : It should be no more than 4.0 ppm tested by Arsenic Limit Test.

(6) Lead : Proceed as directed unde in Purity (2) for Mixed Preparations. Test solution is prepared by purity (2) for 「Sodium Metaphosphate」.

B. Compositional Specifications of Liquid Alkali Additives for Noodles preparations

Content Liquid Alkali Additives for Noodles preparations is an aqueous solution of one or more of sodium salts or potassium salts such as sodium carbonate, potassium carbonate, sodium hydrogencarbonate, and phosphates.

Description Liquid Alkali Additives for Noodles preparations is colorless transparent liquid.

Identification Proceed as directed under Identification in Compositional Specifications of Solid Alkali Additives for Noodles preparations. However, an aqueous solution(1→20) of Liquid Alkali Additives for Noodles preparations is used.

Purity (1) Specific Gravity : Specific Gravity should be 1.20~1.33.

(2) Alkali Metal Hydroxides, Silicates, Chlorides, Arsenic, and Lead : According to the specific gravity in (1), 100 mL solution, containing an amount of sample indicated in Table 1, is prepared (Solution A). Solution A proceed as directed under Purity (2), (3), (4), (5), and (6) in Compositional Specifications of Solid Alkali Additives for Noodles preparations.

Table 1.

s.g.	weight of sample taken(mL)	s.g.	weight of sample taken(mL)	s.g.	weight of sample taken(mL)
1.20	19.9	1.25	15.5	1.30	12.7
1.21	18.8	1.26	14.9	1.31	12.2
1.22	17.8	1.27	14.3	1.32	11.8
1.23	17.0	1.28	13.7	1.33	11.4
1.24	16.2	1.29	13.2		

s.g. : specific gravity

C. Compositional Specifications of Diluted/Powdered Alkali Additives for Noodles preparations

Description Diluted/Powdered Alkali Additives for Noodles preparations is homogeneous white ~ pale yellow powder.

Identification (1) Dissolve 5 g of Diluted/Powdered Alkali Additives for Noodles preparations in 50 mL of water, and stand for a while to settle starch. Discard the supernatant by tilting off. Do the same operation for several times and if iodine is added to some of the debris, it becomes dark indigo color.
(2) Proceed as directed under Identification in Compositional Specifications of Solid Alkali Additives for Noodles preparations. However, Test Solution is prepared by the following procedure. 10 g of Diluted/Powdered Alkali Additives for Noodles preparations, is well mixed with 50 mL of water by shaking, which is then filtered. The filtrate is used instead of the aqueous solution (1→10) for solid alkali additives for noodles preparations.

Purity (1) Specific Gravity : 60 g of Diluted/Powdered Alkali Additives for Noodles preparations is well

mixed in 200 mL of water by shaking, which is filtered. Specific gravity of the filtrate should be 1.12~1.17.

(2) Alkali Metal Hydroxides, Silicates, and Chlorides : According to the specific gravity of the filtrate in (1), take an amount of sample indicated in Table 2, and make to 100 mL solution, is prepared (Solution A). Solution A proceed as directed under Purity (2), (3), and (4) in Compositional Specifications of Solid Alkali Additives for Noodles preparations.

Table 2.

s.g.	weight of sample taken(mL)	s.g.	weight of sample taken(mL)	s.g.	weight of sample taken(mL)
1.12	34.3	1.14	29.2	1.16	25.4
1.13	31.7	1.15	27.2	1.17	23.7

s.g. : specific gravity

(3) Insoluble substances : 100 mL of sodium hydroxide solution (1→100) is added to 0.5 g of Diluted/Powdered Alkali Additives for Noodles preparations, which is heated for 15 minutes, allowed to stand for 30 minutes, and filtered. The residue is washed with water until the filtrate is no longer alkaline. The residue is ignited with the filter paper until the weight becomes constant. The content of insoluble substances should not be more than 10 mg.

(4) Arsenic : It should be no more than 2.5 ppm tested by Arsenic Limit Test.

(5) Lead : Proceed as directed unde in Purity (2) for Mixed Preparations. Test solution is prepared by purity (2) for 「Sodium Metaphosphate」.

Preservatives preparations

Definition Preservative preparations is a mixture of two or more preservatives or a mixture of one or more preservatives with other food additives or diluents for convenience. For the cases where two or more preservatives are mixed, it is mixed and diluted to be appropriate for standards of usage on individual preservative.

Compositional Specifications of Preservatives preparations

Content Preservative preparations should be 90.0~110.0% of the labeled contents.

Identification When Preservative preparations proceed as directed under Identification, labeled preservative should be identified. Salts are identified as acid.

1) Benzoic acid, dehydroacetic acid, sorbic acid, and p-hydroxybenzoic acid esters

(1) Identification by Thin Layer Chromatography

Preparation of Test Solution : Ether is evaporated from the solution obtained by A) Pre-treatment of sample in Assay 1). The residue is dissolved in a small amount of ethyl alcohol (1 ~ 2 mL) (Test Solution) instead of 0.1% acetanilide acetone solution.

Preparation of Thin Layer Plate : Polyamide is mixed with Isopropyl alcohol (20 : 75), which is well shaken to form a paste. It is then formed into a 0.25 mm thick thin film, which is blow dried and then further dried for 30 minutes at 60~70°C.

Test Procedure : 0.2 ~ 1 µg of Test and Preservative Standard Solutions are spotted (at 2 cm distance from each other) at 1 cm position from the bottom and blow dried. It is then developed using solvents 1 ~ 3, which is blow dried. Spots can be observed under a UV light (beam of 2,533°C) or by spraying colorizing solution 1 ~ 3. When colorizing solution 3 is used, color is fixed by spraying 10% sodium hydroxide solution (refer to thin layer chromatography in General Test Methods).

Reagents

- Preservative Standard Solutions : 10 mg of standard (benzoic acid and dehydroacetic acid) is dissolved in 1 mL acetone. 10mg of standard (sorbic acid and p-hydroxybenzoic acid esters) is dissolved in 5 mL of acetone.
- Developing Solvent : 1. hexane, acetic acid (20 : 0.7)
2. benzene, acetic acid (20 : 0.5)
3. benzene, methyl alcohol, acetic acid (20 : 0.2 : 0.5) or (20 : 0.5 : 0.3)
- Colorizing Solution : 1. 2% ferric sulfate solution
2. 0.1% bromcresol green ethyl alcohol solution
3. Diazo(sulfanilic acid) solution : 1 g of sulfanilic acid is dissolved in 3 mL of hydrochloric acid by heating, make 100 mL with water, and added same amount of 0.7% sodium nitrite solution.

(2) Identification by Gas Chromatography

It is tested according to benzoic acid, dehydroacetic acid, sorbic acid, and p-hydroxybenzoic acid esters

of Assay 1).

2) Sodium Propionates and Calcium Propionates

(1) 0.5~1 g of Preservative preparations is dissolved in 10 mL of water. When 10 mL of diluted sulfuric acid is added to this solution and heated, a characteristic odor is generated.

(2) Proceed and identified as directed under in Assay 2) for Propionic Acid.

(3) Preservative (0.5 g as propionic acid) is dissolved in 10 mL of water (and filtered if it is diluted with starch). The solution (or filtrate) shows the reaction of (1)sodium salts or (4) potassium salts of Identification in General Test Methods.

Purity (1) Arsenic : Proceed as directed under in Purity (1) for Mixed Preparations.

(2) Preparations. Lead : Proceed as directed under in Purity (2) for Mixed Preparations.

Assay

1) Benzoic acid, dehydroacetic acid, sorbic acid, and p-hydroxybenzoic acid esters

(1) Gas Chromatography

A) Pretreatment of sample

Sample (corresponding to 50~100 mg as preservatives) is precisely weighed in a beaker and dissolved or dispersed in 100 mL of water. (If it contains oil/fat, sample is neutralized by 10% sodium hydroxide solution or 10% hydrochloric acid and transferred into a 500 mL ~ 1 l round bottom flask, where 5 mL of 15% tartaric acid solution, approximately 80 g of sodium chloride, and 1 drop of silicone resin are added. The total volume is brought up to 150 ~ 200 mL with water. It is then distilled in a steam distillation apparatus. Distillate is collected at a rate of 10 mL per minute up to 500 mL. 100 mL of the distillate is transferred into a beaker.) The content in the beaker is acidified with 10% hydrochloric acid (about pH 2), where 10 g of sodium chloride is dissolved. The resulting solution is extracted 3 times with 40 mL each of ether. The combined ether extracts are washed 3 times with 10 mL each of water and dehydrated with anhydrous sodium sulfate. The solvent is removed by evaporation under vacuum at 20~30°C. The resulting residue is dissolved in 0.1% acetanilide acetone solution so that it contains 0.5 ~ 1.0 mg as preservative (Test Solution). Test Solution is analyzed by the procedures in Gas Chromatography of General Test Methods under the following conditions.

B) Reagents and Conditions

• Standard Solutions : 50 mg each of sorbic acid, benzoic acid, dehydroacetic acid, and p-hydroxybenzoic acid esters is precisely weighed and dissolved in 0.1% acetanilide acetone solution (total volume = 100 mL, 500 µg/mL).

-Column : coated with 1~5% diethylene glycol succinate polyester (DEGS), or 1~10% neopentyl glycol

succinate polyester (NPGS), or silicone 30 on Chromosorb W(60~80 Mesh) .

- Injection Port Temperature : 210~230°C
- Column Temperature : 140~200°C
- Detector Temperature : 230~250°C
- Carrier Gas and Flow Rate : N₂, 30~60 mL/min

(2) Acid · Alkali Neutralization by Titration

Diluent of Single Component : sample (an amount corresponding to 0.2 ~ 0.5 g as preservative) is treated by the procedure in A) Pretreatment of sample in 1) of Assay. The residue obtained after evaporating ether is tested for the Content Test Method for each Compositional Specifications. The content of salts is corrected by converting the content of combined salts.

2) Propionic Acid

(1) Gas Chromatography

Preparation of Test Solution : Sample (50~100 mg as propionic acid) is placed in a 500 mL distillation flask, where 100 mL of water, 40 g of sodium chloride, 10 mL of 10% phosphoric acid, and 1 drop of silicone resin are added. It is then distilled to collect 250 mL of distillate. The end of the condenser is immersed in 10 mL of 1% sodium hydroxide solution. Precisely 25 mL of distillate is taken, and concentrated and dried by evaporation under vacuum. The residue is dissolved in 1 mL of water. This solution is added to the top of the ion exchange resin column. The eluted solution is collected into a 10 mL volumetric flask with 1 mL of internal standard solution. The remaining residue is dissolved in 1 mL each of water at a time. The same procedure is repeated until the total volume of the effluent becomes 10 mL (Test Solution). Test Solution is analyzed by the procedures in Gas Chromatography of General Test Methods under the following conditions.

Operation conditions

Column for Gas Chromatography : Glass or stainless steel tube (3~4 mm × 1~3 m) or its equivalent

Detector : Hydrogen Flame Ionization Detector (FID)

Injection Port Temperature : 200~240°C

Column Temperature : 160~200°C (Chromosorb 101)

110~120°C (AT 1200)

Detector Temperature : 200~250°C

Carrier Gas and Flow Rate : N₂, 30~60 mL/min

Reagents

Propionic Acid Standard Solution : 0.1 g of propionic acid is dissolved in 10 mL of internal standard solution, which is diluted to 100 mL with water (freshly prepared before use).

Sodium Saccharin Preparations

Definition Sodium Saccharin preparations is a mixed and diluted ingredients consisting of 1 or more of glucose, starch, sodium bicarbonate, sodium chloride, or DL-alanine, glycine, D-sorbitol, D-sorbitol solution, or L-sodium glutamate so that it should contain no less than 5% of its major component, sodium saccharin.

Compositional Specifications of Sodium Saccharin preparations

Content Sodium Saccharin preparations should contain 90.0 ~ 110.0% of the labeled amount of sodium saccharin ($C_7H_4O_3NSNa \cdot 2H_2O$).

Description Sodium Saccharin preparations is white ~ pale yellow powder, granule, tablet, or liquid with sweet taste.

Identification (1) sample, corresponding to 2 g of sodium saccharin ($C_7H_4O_3NSNa \cdot 2H_2O$), is precisely weighed and dissolved in 50 mL of water, where 5 mL of diluted hydrochloric acid is added. This solution is extracted three times with 50 mL of ether. The ether layer is washed three times with 10 mL of water. Ether is removed from the extracts and the residue is dried for 2 hours at 105°C. Its melting point should be 224~230°C.

(2) 20 mg of residue in (1) is mixed with 40 mg of resorcin, where 10 drops of sulfuric acid are added. It is then gently heated until the mixture turns dark green. It is then cooled and dissolved by adding 10 mL of water and 10 mL of sodium hydroxide solution. This solution exhibits green fluorescence.

(3) 0.1 g of the extract in (1) is dissolved in 5 mL of sodium hydroxide solution, which is evaporated to dryness. It is melted by carefully heating to avoid carbonization until ammonia odor disappears. After cooling, the residue is dissolved in about 20 mL of water, which is neutralized with diluted hydrochloric acid and filtered. When 1 drop of ferric chloride solution is added to the filtrate, it becomes violet ~ red.

(4) Sodium Saccharin preparations is reduced to ash. These ash show the reactions of sodium salts in Identification.

(5) 1 g of Sodium Saccharin preparations is dissolved in 20 mL of water, where 5 mL of Fehling solution is added. When this solution is heated, red precipitates of copper dioxide are formed.

(6) 0.4 g of Sodium Saccharin preparations is dissolved in 10 mL of diluted sulfuric acid, where 0.2 g of potassium permanganate is added. When this solution is boiled, a odor of acetaldehyde is generated.

(7) 5 g of Sodium Saccharin preparations is dissolved in 50 mL of water, which is allowed to settle for precipitating starch. Supernatant is decanted. The residue is mixed with water. Starch is settled and supernatant is decanted. This is repeated several times. When iodine solution is added to the residue, it becomes dark indigo in color.(Only applies if starch is included)

Purity (1) Arsenic : Proceed as directed under in Purity (1) for Mixed Preparations.

(2) Lead : Proceed as directed unde in Purity (2) for Mixed Preparations.

Assay Sample, corresponding to 0.3 g of sodium saccharin preparations, is precisely weighed and

dissolved in 20 mL of water, which is transferred into a separatory funnel. It is acidified with dilute hydrochloric acid. Precipitates are extracted with 40 mL of mixture of alcohol and chloroform (1:9). It is again extracted 4 times with 20 mL mixture. The extracts are filtered through a filter paper wetted with a mixture of alcohol and chloroform. The filtrate is evaporated to complete dryness. The residue is dissolved in about 75 mL of hot water. After cooling, it is titrated with 0.1 N sodium hydroxide solution (indicator : 3 drops of phenolphthalein solution).

0.1 N sodium hydroxide solution 1 mL = 24.12 mg $C_7H_4O_3NSNa \cdot 2H_2O$

Prepared Tar Dyes preparations

Definition Prepared tar dye preparations is a mixture of 2 or more tar dyes or a mixture of one or more of tar dyes with other food additives or diluents.

Compositional Specifications of Tar Dyes Preparations

Identification (1) Dyes : An aqueous solution is prepared so that the concentration of a dye with the highest content is 0.05%. 0.002 mL of this solution is tested by the procedure in Method 1 of Filter Paper Chromatography (developing solvent : n-butyl alcohol, anhydrous alcohol, 1% ammonia solution = 6 : 2 : 3). Chromatography grade filter paper is used. Developing is stopped when the solvent reaches up to 15 cm and the paper is dried. The spots (positions and colors) of Test Solution and Reference Solution are compared under natural light using white background. If the content of a dye is too minute for detection, then not detected colour exist, this test is repeated with an aqueous solution containing 0.05% of the dye. It is acceptable if the minor pigments are detected from the dyes with higher contents.

(2) Diluents (only when Diluents are used.)

(A) Starch (when dye solution is turbid or precipitates are present) : A certain amount of sample is dissolved in 10 times of water, which is allowed to settle down starch. Supernatant is decanted. The residue is re-mixed with water, which is allowed to settle down starch. Supernatant is decanted. This is repeated several times to decolorize the residue. The residue is tested by the following procedures.

① When iodine solution is added to the residue, it becomes dark indigo in color.

② The residue is suspended in an appropriate amount of water, which is acidified with dilute hydrochloric acid and inverted by heating. This solution is neutralized with sodium hydroxide solution. When Fehling reaction is carried out, red precipitates of copper dioxide are generated.

(B) Glucose and Sugar (when dye solution is clear or precipitates are not present) : an appropriate amount of sample is dissolved in 10 times of water, where an appropriate amount of activated carbon is added. It is decolorized by heating and then filtered. The filtrate is tested by the following procedures.

① Glucose : A portion of this filtrate is neutralized and tested by Fehling reaction. If there is glucose present, red precipitates of copper dioxide are generated.

② Sugar : The remaining filtrate is acidified with diluted hydrochloric acid and inverted by heating. This solution is neutralized with sodium hydroxide solution. When Fehling reaction is carried out, red precipitates of copper dioxide are generated under the presence of sugar.

Purity (1) Arsenic : Proceed as directed under in Purity (1) for Mixed Preparations.

(2) Lead : Proceed as directed under in Purity(2) for Mixed Preparations.

Baking Powder Preparations

Baking Powder

Compositional Specifications of Baking Powder Preparations

Baking Powder, Type 1 Baking powder of type 1 is a raising agent, containing carbonates or bicarbonates, prepared by mixing acidic compounds.

Ammonium baking powder is excluded.

Description Baking powder preparations is white ~ grayish white powder or fragile lump.

Purity (1) Nitric Acid Insoluble substances : 5 g of Baking powder preparations is mixed for 3 minutes in 30 mL of water, which is filtered. The insoluble substances are washed thoroughly with water. The bottom of filter paper is punctured and the insoluble substances are rinsed with 40 mL of diluted nitric acid into a beaker. It is boiled for 1 minute, cooled, and filtered through a Gooch crucible. The insoluble substances are washed with water until the filtrate is no longer acidic. The insoluble substances (along with the crucible) are dried by heating until the weight becomes constant. The amount of the residues should not be more than 0.1g. (Should not be more than 2%).

(2) pH : When 1 g of Baking powder preparations is mixed in 50 mL of water, which is heated until bubbling stops and cooled, pH of the liquid should be 5.0~8.5.

(3) Arsenic : It should be no more than 4.0 ppm tested by Arsenic Limit Test.

(4) Lead : Proceed as directed under in Purity (2) for Mixed Preparations. Test solution is prepared by purity (2) for 「Sodium Metaphosphate」.

(5) Amount of Evolving Gas : When the amount of evolving gas is measured, it should not be less than 70 mL.

Baking Powder, Type 2 Baking powder of type 2 is a raising agent, containing carbonates or bicarbonates, separately packaged and prepared for mixing just before using it. It should follow the specifications and procedures for Baking Powder, Type 1. However, pH in Purity (2) should be 4.0~8.5.

Ammonium baking powder Baking powder preparations is a baking powder with ammonia salts as its major components. It is tested by the specifications and procedures for Baking Powder, Type 1. However, pH in Purity (2) should be 6 ~ 9. Amount of evolving gas in Purity (5) is measured with water in a leveling bottle instead of diluted sulfuric acid.

Mixed preparations

Definition Mixed preparations is a mixture of two or more food additives or a mixture of one or more additives with diluents. However, if an individual component has its own specifications, it is not regulated by the specifications provided in this section.

Compositional Specifications of Mixed preparations

Description There should not be any color, taste, or odor other than mixed additives. It is a powder, crystallite, or liquid, etc.

Purity (1) Arsenic : It should be no more than 4.0 ppm tested by Arsenic Limit Test. The amount should be no more than the sum amount calculated as a percentage of arsenic in individual compounds, tested by Arsenic Limit Test. However, if there is no specification of compound(food additive), its arsenic amount shall be 4.0 ppm, arsenic amount of diluting agent which is food ingredient shall be 1.5 ppm(Arsenic trioxide, As_2O_3). The sum of arsenic amounts shall be rounded up from the second decimal place.

(2) Lead : When 5.0 g of Mixed preparations is tested by Atomic Absorption Spectrophotometry or Inductively Coupled Plasma Emission Spectroscopy, the lead amount should be no more than the sum amount calculated as a percentage of lead in individual compounds. However, if there is no specification of compound(food additive), its lead amount shall be 10 ppm, lead amount of diluting agent which is food ingredient shall be 1.0 ppm, and lead amount of water shall be 0.05 ppm. The sum of lead amounts shall be rounded up from the second decimal place

5. Use Level of each food additive

A. Food additives

The following additives should be used in accordance with each use level. However, if there is no specified use level of food additive, it should be used in accordance with the section II.2.1).

Food additive	Use Level	Major functional class
Acesulfame Potassium	<p>The usage of Acesulfame Potassium should be</p> <ol style="list-style-type: none"> 1. Confectionery, boiled foods(only with agricultural products as main ingredient): no more than 2.5g/kg 2. Chewing gum: no more than 5.0g/kg 3. Sauce, candies, jams, pickled food products, frozen confectionery products, ice creams, ice cream mixes and flour pastes: no more than 1.0g/kg 4. Beverages, processed milk, fermented milk: no more than 0.50g/kg (However, the product that is to be diluted before drinking is based on the diluted form) 5. Sugar substitute product: no more than 15g/kg 6. Cereals: no more than 1.2g/kg 7. Foods for special medical purpose: no more than 0.5g/kg 8. Weight control formulas: no more than 0.45g/kg 9. Other foods: no more than 0.35g/kg 10. Health functional food: no more than 2.0g/kg(However, for the health functional food which is drank by dilution, it should be no more than 6.0g/kg) 	Sweetener
Acetic Acid	It should be used in accordance with Section II.2.1).	Acidity regulator

Food additive	Use Level	Major functional class
α-Acetolactate decarboxylase	It should be used in accordance with Section II.2.1).	Enzyme preparations
Acetone	Acetone should be used only for the following food items or function. 1. For the separation of oil ingredients.(However, it should be removed before the final product is completed.) 2. For the extraction or the separation of the functional raw material for health functional food: not more than 0.03g/kg(The residual amount as acetone)	Extraction solvent
Acetophenone	Acetophenone should be used for flavorings only.	Flavouring agent
Acid Clay	Acid Clay should be used only for a filtering aid(filtering, discoloring, deodorizing, refining, and etc.) in food manufacturing or processing. However, it should be removed before the final product is completed. The residual amount should be no more than 0.5%.(if it is used with diatomaceous earth, kaolin, bentonite, talc, perlite, activated carbon, and other insoluble minerals, the sum of the residues should be no more than 0.5%).	Filter aid
Active Carbon	Active Carbon should be used only for a filtering aid(filtering, discoloring, deodorizing, refining, etc.) in food manufacturing or processing. However, it should be removed before the final product is completed. The residual amount should be no more than 0.5%.(if it is used with diatomaceous earth, kaolin, bentonite, talc, perlite, acid clay, and other insoluble minerals, the sum of the residues should be no more than 0.5%).	Filter aid

Food additive	Use Level	Major functional class
5'-Adenylic Acid	5'-Adenylic acid should be used only for the following food items and the usage should be 1. Milk formulas, infant formulas, follow-up formulas, Cereal formulas for infants/young children, other foods for infants/young children and formulas for infants/young children with milk protein allergy, special formulas for infants/young children: no more than 0.075g/kg	Fortifying nutrient
Adipic Acid	It should be used in accordance with Section II.2.1).	Acidity regulator Raising agent
DL-Alanine	It should be used in accordance with Section II.2.1).	Fortifying nutrient
L-Alanine	It should be used in accordance with Section II.2.1).	Fortifying nutrient
Alfalfa Extract	Alfalfa Extract should not be used in the food items listed below. 1. Natural food[meat, fishes and shellfishes, fruits, vegetables, algae, Legume vegetables and pulses, and their simply processed food(peeled, cut, and etc.)] 2. Teas 3. Coffee 4. Hot pepper powder, shredded hot pepper 5. <i>Kimchi</i> products 6. <i>Gochujang</i> (hot pepper soy paste), seasoned hot pepper soy paste 7. Vinegars	Colour
Alginic Acid	It should be used in accordance with Section II.2.1).	Emulsifier Thickener Stabilizer

Food additive	Use Level	Major functional class
Allyl Caproate	Allyl Caproate should be used for flavorings only.	Flavouring agent
Allyl Cyclohexanepropionate	Allyl Cyclohexanepropionate should be used for flavorings only.	Flavouring agent
Allyl Isothiocyanate	Allyl Isothiocyanate should be used for flavorings only.	Flavouring agent
Aluminium Ammonium Sulfate	Aluminum ammonium sulfate should not be used for Korean-style doenjang(soybean paste), Doenjang(soybean paste), and seasoned soybean paste.	Acidity regulator Raising agent

Food additive	Use Level	Major functional class
	<p align="center"><MFDS regulation 2018-53, 2018.6.29.> [Enforcement date: 2019.7.1.]</p> <p>Aluminium Ammonium Sulfate should be used only for the following food items. The usage as aluminium should be</p> <ol style="list-style-type: none"> 1. Confectionery, mixes for confectionery, Breads, mixes for breads, mixes for frying: no more than 0.1g/kg(if it is used with Aluminium Potassium Sulfate, Sodium Aluminium Phosphate, Acidic, Sodium Aluminium Phosphate, Basic, the total of usage as aluminium should be no more than 0.1g/kg.) 2. Processed peanut or nut product(chestnuts only), processed tuberous and corn vegetable product(sweet potatoes only), other processed fish meat products, processed fruit/vegetable product : no more than 0.1g/kg(if it is used with Aluminium Potassium Sulfate, the total of usage as aluminium should be no more than 0.1g/kg) 3. Noodles, mixes for noddles, other processed fishery products, processed starch product: not more that 0.2g/kg(if it is used along with Aluminium Potassium Sulfate, the total of usage as aluminium should be no more than 0.2g/kg.) 4. Pickled food: not more than 0.5g/kg(if it is used along with Aluminium Potassium Sulfate, the total of usage as aluminium should be no more than 0.5g/kg.) 	Stabilizer
Aluminium Potassium Sulfate	Aluminum potassium sulfate should not be used for Korean-style doenjang(soybean paste), Doenjang(soybean paste), and seasoned soybean	Acidity regulator Raising

Food additive	Use Level	Major functional class
	<p>paste.</p> <p><MFDS regulation 2018-53, 2018.6.29.> [Enforcement date: 2019.7.1.]</p> <p>Aluminium Potassium Sulfate should be used only for the following food items. The usage as aluminium should be</p> <ol style="list-style-type: none"> 1. Confectionery, mixes for confectionery, Breads, mixes for breads, mixes for frying: no more than 0.1g/kg(if it is used with Aluminium Ammonium Sulfate, Sodium Aluminium Phosphate, Acidic, Sodium Aluminium Phosphate, Basic, the total of usage as aluminium should be no more than 0.1g/kg.) 2. Processed peanut or nut product(chestnuts only), processed tuberos and corm vegetable product(sweet potatoes only), other processed fish meat products, processed fruit/vegetable product : no more than 0.1g/kg(if it is used with Aluminium Ammonium Sulfate, the total of usage as aluminium should be no more than 0.1g/kg) 3. Noodles, mixes for noddles, other processed fishery products, processed starch product: not more that 0.2g/kg(if it is used along with Aluminium Ammonium Sulfate, the total of usage as aluminium should be no more than 0.2g/kg.) 4. Pickled food: not more than 0.5g/kg(if it is used along with Aluminium Ammonium Sulfate, the total of usage as aluminium should be no more than 0.5g/kg.) 	<p>agent Stabilizer</p>

Food additive	Use Level	Major functional class
Amidated Pectin	It should be used in accordance with Section II.2.1).	Thickener
Ammonium Alginate	It should be used in accordance with Section II.2.1).	Emulsifier Thickener Stabilizer
Ammonium Bicarbonate	It should be used in accordance with Section II.2.1).	Acidity regulator Raising agent
Ammonium Carbonate	It should be used in accordance with Section II.2.1).	Acidity regulator Raising agent
Ammonium Chloride	It should be used in accordance with Section II.2.1).	Raising agent
Ammonium Hydroxide	It should be used in accordance with Section II.2.1).	Acidity regulator
Ammonium Molybdate	Ammonium Molybdate should be used only for 1. Foods for special medical purposes 2. Health functional food	Fortifying nutrient
Ammonium Persulfate	Ammonium Persulfate should be used only for the following food item. the usage should be 1. Wheat flour products : no more than 0.3g/kg	Flour treatment agent
Ammonium Phosphate, Dibasic	It should be used in accordance with Section II.2.1).	Acidity regulator Raising agent
Ammonium Phosphate, Monobasic	It should be used in accordance with Section II.2.1).	Acidity regulator Raising

Food additive	Use Level	Major functional class
		agent
Ammonium Phosphatides	Ammonium Phosphatides should be used only for the following food item. The usage should be 1. Other cocoa products, chocolates: no more than 10g/kg	Emulsifier
Ammonium Sulfate	It should be used in accordance with Section II.2.1).	Raising agent
α-Amylase	It should be used in accordance with Section II.2.1).	Enzyme preparations
β-Amylase	It should be used in accordance with Section II.2.1).	Enzyme preparations
α-Amylcinnamaldehyde	α -Amylcinnamaldehyde should be used for flavorings only.	Flavouring agent
Anisaldehyde	Anisaldehyde should be used for flavorings only.	Flavouring agent
Annatto Extract	Annatto Extract should not be used in the following food items. 1. Natural food[meat, fishes and shellfishes, fruits, vegetables, algae, Legume vegetables and pulses, and their simply processed food(peeled, cut, and etc.)] 2. Teas 3. Coffee 4. Hot pepper powder, shredded hot pepper 5. <i>Kimchi</i> products 6. <i>Gochujang</i> (hot pepper soy paste), seasoned hot pepper soy paste 7. Vinegars 8. Spice products(only the products containing	Colour

Food additive	Use Level	Major functional class
	hot pepper or hot pepper powder)	
Annatto, Water-Soluble	<p>Annatto, Water-soluble should not be used in the following food items.</p> <ol style="list-style-type: none"> 1. Natural food[meat, fishes and shellfishes, fruits, vegetables, algae, Legume vegetables and pulses, and their simply processed food(peeled, cut, and etc.)] 2. Teas 3. Coffee 4. Hot pepper powder, shredded hot pepper 5. <i>Kimchi</i> products 6. <i>Gochujang</i>(hot pepper soy paste), seasoned hot pepper soy paste 7. Vinegars 8. Spice Products(only the products containing hot pepper or hot pepper powder) 	Colour

Food additive	Use Level	Major functional class
β-Apo-8'-Carotenal	<p>β-Apo-8'-Carotenal should not be used in the following food items.</p> <ol style="list-style-type: none"> 1. Natural food[meat, fishes and shellfishes, fruits, vegetables, algae, Legume vegetables and pulses, and their simply processed food(peeled, cut, and etc.)] 2. Teas 3. Coffee 4. Hot pepper powder, shredded hot pepper 5. <i>Kimchi</i> products 6. <i>Gochujang</i>(hot pepper soy paste), seasoned hot pepper soy paste 7. Vinegars 	Colour
Arabic Gum	It should be used in accordance with Section II.2.1).	Thickener Stabilizer
Arabino Galactan	It should be used in accordance with Section II.2.1).	Thickener Stabilizer
L-Arginine	It should be used in accordance with Section II.2.1).	Fortifying nutrient

Food additive	Use Level	Major functional class
<p>L-Ascorbyl Palmitate</p>	<p>L-Ascorbyl Palmitate should be used only for the following food items. The usage should be</p> <ol style="list-style-type: none"> 1. Edible fats and oils(excluding imitation cheese and vegetable cream): no more than 0.5g/kg(if it is used with L-ascorbyl stearate, the total usage of L-ascorbyl palmitate and L-ascorbyl stearate should be no more than 0.5g/kg) 2. Mayonnaise: no more than 0.5 g/kg 3. Milk Formulas, infant formulas, follow-up formulas, formulas for infants/young children with milk protein allergy, special formulas for infants/young children: no more than 0.05g/L(for standard milk formula concentration) 4. Cereal formulas for infants/young children, other foods for infants/young children: no more than 0.2g/L (for standard milk formula concentration) 5. Other foods: no more than 1.0g/kg(In the case of health functional food, it should be in accordance with the Health Functional Food Code) 	<p>Antioxidant Fortifying nutrient</p>

Food additive	Use Level	Major functional class
	<p style="text-align: center;"><MFDS regulation 2018-84, 2018.11.1.> <u>[Enforcement date: 2019.7.1.]</u> <MFDS regulation 2019-1, 2019.1.9.> <u>[Enforcement date: 2019.7.1.]</u></p> <p>L-Ascorbyl Palmitate should be used only for the following food items. The usage should be</p> <ol style="list-style-type: none"> 1. Edible fats and oils(excluding imitation cheese and vegetable cream): no more than 0.5g/kg(if it is used with L-ascorbyl stearate, the total usage of L-ascorbyl palmitate and L-ascorbyl stearate should be no more than 0.5g/kg) 2. Mayonnaise: no more than 0.5 g/kg 3. Other foods: no more than 1.0g/kg(In the case of health functional food, it should be in accordance with the Health Functional Food Code) 3. Confectionery, Breads, Rice Cakes, Processed Saccharide Product, Liquid tea, Foods for special Medical Purposes(Excluding Special formulas for infants/young children), Weight Control Formulas, Foods for Pregnant/Lactating women, Alcoholic Beverages, Processed fruit/vegetable product, Processed tuberous and corm vegetable product, Processed Fish Meat Products, Other Processed Fishery Products, Other processed Products : no more than 1.0 g/kg 4. Candies, Cocoa Products or Chocolates, Oil-fied noodle, Composite seasoning, Spice preparation, Dumpling skin : no more than 0.5 g/kg 5. Health functional foods are followed by it's regulation. 	

Food additive	Use Level	Major functional class
L-Ascorbyl Stearate	<p>L-Ascorbyl Stearate should be used only for the following food items.</p> <ol style="list-style-type: none"> 1. Edible fats and oils(excluding imitation cheese and vegetable cream): no more than 0.5g/kg(if it is used with L-ascorbyl palmitate, the total usage of L-ascorbyl stearate and L-ascorbyl palmitate should be no more than 0.5g/kg) 2. Health functional food 	Antioxidant Fortifying nutrient
Asparaginase	It should be used in accordance with Section II.2.1).	Enzyme preparations
L-Asparagine	It should be used in accordance with Section II.2.1).	Fortifying nutrient
Aspartame	<p>The usage of Aspartame is as follows. Other foods are not restricted.</p> <ol style="list-style-type: none"> 1. Breads, confectionery, mixes for breads, mixes for confectionery: Not more than 5.0g/kg 2. Cereals: Not more than 1.0g/kg 3. Foods for special medical purposes: Not more than 1.0g/kg 4. Weight control formulas: Not more than 0.8g/kg 5. Health functional food: Not more than 5.5g/kg 	Sweetener
L-Aspartic Acid	It should be used in accordance with Section II.2.1).	Fortifying nutrient
Azodicarbonamide	<p>Azodicarbonamide should be used only for the following food item.</p> <ol style="list-style-type: none"> 1. Wheat flour products: not more than 45mg/kg 	Flour treatment agent
Beeswax	It should be used in accordance with Section II.2.1).	Coating agent

Food additive	Use Level	Major functional class
Beet Red	<p>Beet Red should not be used in the food items listed below.</p> <ol style="list-style-type: none"> 1. Natural food[meat, fishes and shellfishes, fruits, vegetables, algae, Legume vegetables and pulses, and their simply processed food(peeled, cut, and etc.)] 2. Teas 3. Coffee 4. Hot pepper powder, shredded hot pepper 5. <i>Kimchi</i> products 6. <i>Gochujang</i>(hot pepper soy paste), seasoned hot pepper soy paste 7. Vinegars 8. Spice products(only the products containing hot pepper or hot pepper powder) 	Colour
Bentonite	<p>Bentonite should be used only for a filtering aid(filtering, discoloring, deodorizing, refining, and etc.) in food manufacturing or processing. However, it should be removed before the final product is completed. The residual amount should be no more than 0.5%.(if it is used with diatomaceous earth, kaolin, acid clay, talc, perlite, activated carbon, and other insoluble minerals, the sum of the residues should be no more than 0.5%).</p>	Filtering aid
Benzaldehyde	Benzaldehyde should be used for flavorings only.	Flavouring agent

<p>Benzoic Acid</p>	<p>Benzoic acid should be used only for the following food items. The usage as benzoic acid should be</p> <ol style="list-style-type: none"> 1. Fruit/vegetable beverages(excluding non-heated products): No more than 0.6g/kg(In the case of concentrated fruit juice, fruit/vegetable juice, if it is used with sorbic acid, potassium sorbate, or calcium sorbate, the sum of usage as benzoic acid and sorbic acid should be no more than 1.0 g/kg, and the usage of benzoic acid should be no more than 0.6g/kg) 2. Carbonated beverage: No more than 0.6g/kg(If it is used with sorbic acid, potassium sorbate or calcium sorbate, the sum of usage as benzoic acid and sorbic acid should be no more than 0.6g/kg, and the usage as sorbic acid should be no more than 0.5g/kg) 3. Other beverages(excluding powder products), ginseng/red ginseng beverages: No more than 0.6g/kg(if it is used with ethyl p-hydroxybenzoate or methyl p-hydroxybenzoate, the sum of usage as benzoic acid and p-hydroxybenzoic acid should be no more than 0.6g/kg, and the usage as p-hydroxybenzoic acid should be no more than 0.1g/kg) 4. Korean-style soy sauce, brewed soy sauce, acid-hydrolyzed soy sauce, enzyme-hydrolyzed soy sauce, blended soy sauce: No more than 0.6g/kg(if it is used with ethyl p-hydroxybenzoate or Methyl p-hydroxybenzoate, the sum of usage as benzoic acid and p-hydroxybenzoic acid should be no more than 0.6g/kg, and the usage as p-hydroxybenzoic acid should be no more than 0.25g/kg) 5. Aloe whole leaves(including Aloe gel) health functional food(However, in the case of using more than two kinds of health functional food 	<p>Preservative</p>
----------------------------	--	---------------------

materials, apply proportion of the aloe whole leaves(including the aloe gel) health functional food content): No more than 0.5g/kg(if it is used with sorbic acid, potassium sorbate, or calcium sorbate, the sum of usage as benzoic acid and sorbic acid should be no more than 1.5g/kg, and the usage of sorbic acid should be no more than 1.0g/kg)

6. Mayonnaise: No more than 1.0g/kg

7. Jams: No more than 1.0g/kg(if it is used with sorbic acid, potassium sorbate, calcium sorbate, methyl *p*-hydroxybenzoate, ethyl *p*-hydroxybenzoate, propionic acid, sodium propionate, or calcium propionate, the sum of usage as benzoic acid, sorbic acid, *p*-hydroxybenzoic acid, and propionic acid should be no more than 1.0 g/kg)

8. Mango chutney: No more than 0.25g/kg(if it is used with Methyl *p*-hydroxybenzoate or ethyl *p*-hydroxybenzoate, the sum of usage as benzoic acid and *p*-hydroxybenzoic acid should be no more than 0.25g/kg).

9. Margarine: No more than 1.0g/kg(if it is used with sorbic acid, potassium sorbate or calcium sorbate, the sum of usage as sorbic acid and benzoic acid should be no more than 2.0g/kg, and the usage as benzoic acid should be no more than 0.1g/kg)

10. Pickled food: No more than 1.0g/kg(if it is used with sorbic acid, potassium sorbate or calcium sorbate, the sum of usage as benzoic acid and sorbic acid should be no more than 1.5g/kg, and the usage of sorbic acid should be no more than 1.0g/kg)

Food additive	Use Level	Major functional class
Benzyl Acetate	Benzyl Acetate should be used for flavorings only.	Flavouring agent
Benzyl Alcohol	Benzyl Alcohol should be used for flavorings only.	Flavouring agent
Benzyl Propionate	Benzyl Propionate should be used for flavorings only.	Flavouring agent
Berries Color	<p>Berries Color should not be used in the following food items.</p> <ol style="list-style-type: none"> 1. Natural food[meat, fishes and shellfishes, fruits, vegetables, algae, Legume vegetables and pulses, and their simply processed food(peeled, cut, and etc.)] 2. Teas 3. Coffee 4. Hot pepper powder, shredded hot pepper 5. <i>Kimchi</i> products 6. <i>Gochujang</i>(hot pepper soy paste), seasoned hot pepper soy paste 7. Vinegars 8. Spice Products(only the products containing hot pepper or hot pepper powder) 	Colour
Betaine	It should be used in accordance with Section II.2.1).	Flavour enhancer
Biotin	It should be used in accordance with Section II.2.1).	Fortifying nutrient
Black carrot extract	<p>Black carrot extract should be used only for the following food item.</p> <ol style="list-style-type: none"> 1. Candies 	Colour
Branching glycosyltransferase	It should be used as in accordance with the Section.II.2.1).	Enzyme preparations

Food additive	Use Level	Major functional class
Butane	<p>Butane should be used only for the following food items or function, and it should be removed before the final product is completed.</p> <ol style="list-style-type: none"> 1. For extracting fats and oil component when manufacturing edible fats and oils 2. For extracting or separating functional material of health functional food 	Extraction solvent
Butyl Acetate	Butyl Acetate should be used for flavorings only.	Flavouring agent
Butyl Butyrate	Butyl Butyrate should be used for flavorings only.	Flavouring agent

Food additive	Use Level	Major functional class
<p>Butylated Hydroxy Anisole</p>	<p>Butylated Hydroxy Anisole should be used only for the following food items. The usage should be</p> <ol style="list-style-type: none"> 1. Edible fats and oils(excluding imitation cheese and vegetable cream), butters, dried fish and shellfish, salted fish and shellfish: no more than 0.2g/kg(If it is used with butyl hydroxy toluene or tertiary-butyl hydroquinone, the sum of usage as butylated hydroxy anisole, butyl hydroxy toluene and tertiary-butyl hydroquinone should be no more than 0.2g/kg) 2. Immersion solution of frozen fish and shellfish(excluding frozen fresh fish and shellfish, and raw oysters): no more than 1g/kg(If it is used with butyl hydroxy toluene or tertiary-butyl hydroquinone, the sum of usage as butylated hydroxy anisole, butyl hydroxy toluene and tertiary-butyl hydroquinone should be no more than 1g/kg) 3. Chewing gum: no more than 0.4g/kg (If it is used with butyl hydroxy toluene or tertiary-butyl hydroquinone, the sum of usage as butylated hydroxy anisole, butyl hydroxy toluene and tertiary-butyl hydroquinone should be no more than 0.4 g/kg) 4. Weight control formulas, cereals: no more than 0.05g/kg (If it is used with butyl hydroxy toluene, sum of usage as butylated hydroxy anisole and butyl hydroxy toluene should be no more than 0.05g/kg) 5. Mayonnaise: no more than 0.14g/kg 	<p>Antioxidant</p>

Food additive	Use Level	Major functional class
<p>Butylated Hydroxy Toluene</p>	<p>Butylated Hydroxy Toluene should be used only for the following food items. The usage should be</p> <ol style="list-style-type: none"> 1. Edible fats and oils(excluding imitation cheese and vegetable cream), butters, dried fish and shellfish, salted fish and shellfish: no more than 0.2g/kg(If it is used with butyl hydroxy anisole or tertiary-butyl hydroquinone, the sum of usage as butyl hydroxy toluene, butylated hydroxy anisole and tertiary-butyl hydroquinone should be no more than 0.2g/kg) 2. Immersion solution of frozen fish and shellfish(excluding frozen fresh fish and shellfish, and raw oysters): no more than 1g/kg(If it is used with butyl hydroxy anisole or tertiary-butyl hydroquinone, the sum of usage as butyl hydroxy toluene, butylated hydroxy anisole and tertiary-butyl hydroquinone should be no more than 1g/kg) 3. Chewing gum: no more than 0.4g/kg(If it is used with butyl hydroxy anisole or tertiary-butyl hydroquinone, the sum of usage as butyl hydroxy toluene, butylated hydroxy anisole and tertiary-butyl hydroquinone should be no more than 0.4g/kg) 4. Weight control formulas, cereals: no more than 0.05g/kg (If it is used with butyl hydroxy anisole, the sum of usage as butylated hydroxy toluene and butyl hydroxy anisole should be no more than 0.05g/kg) 5. Mayonnaise: no more than 0.06g/kg 	<p>Antioxidant</p>

Food additive	Use Level	Major functional class
tert-Butylhydroquinone	<p>tert-Butylhydroquinone should be used only for the following food items. The usage should be</p> <ol style="list-style-type: none"> 1. Edible fats and oils(excluding imitation cheese and vegetable cream), butters, dried fish and shellfish, salted fish and shellfish: no more than 0.2g/kg(If it is used with butyl hydroxy anisole or butylated hydroxy toluene, the sum of usage as tertiary-butyl hydroquinone, butyl hydroxy toluene and butylated hydroxy anisole should be no more than 0.2g/kg) 2. Immersion solution of frozen fish and shellfish(excluding frozen fresh fish and shellfish, and raw oysters): no more than 1g/kg (If it is used with butyl hydroxy anisole or butylated hydroxy toluene, the sum of usage as tertiary-butyl hydroquinone, butyl hydroxy toluene and butylated hydroxy anisole should be no more than 1 g/kg) 3. Chewing gum: no more than 0.4g/kg(If it is used with butyl hydroxy anisole or butylated hydroxy toluene, the sum of usage as tertiary-butyl hydroquinone, butyl hydroxy toluene and butylated hydroxy anisole should be no more than 0.4g/kg) 	Antioxidant
Butyric Acid	Butyric Acid should be used for flavorings only.	Flavouring agent

Food additive	Use Level	Major functional class
Cacao Color	<p>Cacao color should not be used in the food items listed below.</p> <ol style="list-style-type: none"> 1. Natural food[meat, fishes and shellfishes, fruits, vegetables, algae, Legume vegetables and pulses, and their simply processed food(peeled, cut, and etc.)] 2. Teas 3. Coffee 4. Hot pepper powder, shredded hot pepper 5. <i>Kimchi</i> products 6. <i>Gochujang</i>(hot pepper soy paste), seasoned hot pepper soy paste 7. Vinegars 	Colour
Caffeine	<p>Caffeine should be used only for carbonated beverage. The usage of caffeine should be no more than 0.015%.(If the product is beverage base that is intend to use by diluting five times for consumption and final food category of the product correspond to the carbonated beverage, the usage of the beverage base product should be no more than 0.075%.</p>	Flavour enhancer
Calcium Acetate	<p>It should be used in accordance with Section II.2.1).</p>	Acidity regulator
Calcium Alginate	<p>It should be used in accordance with Section II.2.1).</p>	Emulsifier Thickener Stabilizer
Calcium L-Ascorbate	<p>It should be used in accordance with Section II.2.1).</p>	Fortifying nutrient Antioxidant

<p>Calcium Benzoate</p>	<p>Calcium Benzoate should be used only for the following food items. The usage as benzoic acid should be</p> <ol style="list-style-type: none"> 1. Fruit/vegetable beverages(excluding non-heated products): No more than 0.6g/kg(In the case of concentrated fruit juice, fruit/vegetable juice, if it is used with sorbic acid, potassium sorbate, or calcium sorbate, the sum of usage as benzoic acid and sorbic acid should be no more than 1.0 g/kg, and the usage of benzoic acid should be no more than 0.6g/kg) 2. Carbonated beverage: No more than 0.6g/kg(If it is used with sorbic acid, potassium sorbate or calcium sorbate, the sum of usage as benzoic acid and sorbic acid should be no more than 0.6g/kg, and the usage as sorbic acid should be no more than 0.5g/kg) 3. Other beverages(excluding powder products), Ginseng/red ginseng beverages: No more than 0.6g/kg(if it is used with ethyl p-hydroxybenzoate or methyl p-hydroxybenzoate, the sum of usage as benzoic acid and p-hydroxybenzoic acid should be no more than 0.6g/kg, and the usage as p-hydroxybenzoic acid should be no more than 0.1g/kg) 4. Korean-style soy sauce, brewed soy sauce, acid-hydrolyzed soy sauce, enzyme-hydrolyzed soy sauce, blended soy sauce: No more than 0.6g/kg(if it is used with ethyl p-hydroxybenzoate or Methyl p-hydroxybenzoate, the sum of usage as benzoic acid and p-hydroxybenzoic acid should be no more than 0.6g/kg, and the usage as p-hydroxybenzoic acid should be no more than 0.25g/kg) 5. Aloe whole leaves(including Aloe gel) health functional food(However, in the case of using 	<p>Preservative</p>
--------------------------------	--	---------------------

more than two kinds of health functional food materials, apply proportion of the aloe whole leaves(including the aloe gel) health functional food content): No more than 0.5g/kg(if it is used with sorbic acid, potassium sorbate, or calcium sorbate, the sum of usage as benzoic acid and sorbic acid should be no more than 1.5g/kg, and the usage of sorbic acid should be no more than 1.0g/kg)

6. Mayonnaise: No more than 1.0g/kg
7. Jams: No more than 1.0g/kg(if it is used with sorbic acid, potassium sorbate, calcium sorbate, methyl ρ -hydroxybenzoate, ethyl ρ -hydroxybenzoate, propionic acid, sodium propionate, or calcium propionate, the sum of usage as benzoic acid, sorbic acid, ρ -hydroxybenzoic acid, and propionic acid should be no more than 1.0 g/kg)
8. Mango chutney: No more than 0.25g/kg(if it is used with Methyl ρ -hydroxybenzoate or ethyl ρ -hydroxybenzoate, the sum of usage as benzoic acid and ρ -hydroxybenzoic acid should be no more than 0.25g/kg).
9. Margarine: No more than 1.0g/kg(if it is used with sorbic acid, potassium sorbate or calcium sorbate, the sum of usage as sorbic acid and benzoic acid should be no more than 2.0g/kg, and the usage as benzoic acid should be no more than 0.1g/kg)
10. Pickled food: No more than 1.0g/kg(if it is used with sorbic acid, potassium sorbate or calcium sorbate, the sum of usage as benzoic acid and sorbic acid should be no more than 1.5g/kg, and the usage of sorbic acid should be no more than 1.0g/kg)

Food additive	Use Level	Major functional class
Calcium Carbonate	It should be used in accordance with Section II.2.1).	Acidity regulator Fortifying nutrient Raising agent Gum base
Calcium Carboxymethylcellulose	The usage of Calcium Carboxymethylcellulose should be no more than 2% of the food item(if it is used with methylcellulose, sodium carboxymethylcellulose or sodium carboxymethyl starch, the sum of usage should be no more than 2 % of the food item). However, health functional food should not be restricted.	Thickener Stabilizer
Calcium Caseinate	It should be used in accordance with Section II.2.1).	Emulsifier Thickener Stabilizer
Calcium Chloride	It should be used in accordance with Section II.2.1).	Tofu Firming agent Fortifying nutrient
Calcium Citrate	It should be used in accordance with Section II.2.1).	Acidity regulator Fortifying nutrient

Food additive	Use Level	Major functional class
<p>Calcium Disodium Ethylenediaminetetraacetate</p>	<p>Calcium Disodium Ethylenediaminetetraacetate should be used only for the following food items. The usage as anhydrous Calcium Disodium Ethylenediaminetetraacetate should be</p> <ol style="list-style-type: none"> 1. Sauce, mayonnaise: no more than 0.075g/kg(if it is used with EDTA disodium, the sum of usage as anhydrous EDTA disodium should be 0.075g/kg) 2. Canned or bottled foods: no more than 0.25g/kg(if it is used with EDTA disodium, the sum of usage as anhydrous EDTA disodium should be 0.025g/kg) 3. Beverages(only canned or bottled products, and excluding teas and coffee): no more than 0.035g/kg(if it is used with EDTA disodium, the sum of usage as anhydrous EDTA disodium should be 0.035g/kg) 4. Margarine: no more than 0.1g/kg(if it is used with EDTA disodium, the sum of usage as anhydrous EDTA disodium should be 0.1g/kg) 5. Vinegar-pickled cucumber and vinegar-pickled cabbage: no more than 0.22g/kg(if it is used with EDTA disodium, the sum of usage as anhydrous EDTA disodium should be 0.22g/kg) 6. Dried fruits(only bananas): no more than 0.265g/kg(if it is used with EDTA disodium, the sum of usage as anhydrous EDTA disodium should be 0.265g/kg) 7. Processed tuberous and corn vegetable product(only frozen potatoes): no more than 0.365g/kg(if it is used with EDTA disodium, the sum of usage as anhydrous EDTA disodium 	<p>Antioxidant</p>

Food additive	Use Level	Major functional class
	<p>should be 0.365g/kg)</p> <p>8. Peanut butter: no more than 0.1g/kg(if it is used with EDTA disodium, the sum of usage as anhydrous EDTA disodium should be 0.1g/kg)</p>	

Food additive	Use Level	Major functional class
Calcium Dihydrogen Pyrophosphate	It should be used in accordance with Section II.2.1).	Acidity regulator Raising agent
Calcium Ferrocyanide	Calcium Ferrocyanide should be used only for edible salts. The usage as ferrocyanide ion should be 1. Edible slats: no more than 0.010g/kg(if it is used with potssium ferrocyanide or sodium ferrocyanide, the sum of usage as ferrocyanide ion should be no more than 0.010g/kg)	Anticaking agent

Food additive	Use Level	Major functional class
Calcium Gluconate	<p>The usage of Calcium Gluconate as calcium should be</p> <ol style="list-style-type: none"> 1. Breads: no more than 1.75% 2. Other foods: no more than 1%(However, in the case of Foods for special dietary uses and Health functional food, they should be in accordance with their food codes.) 	<p>Acidity regulator Fortifying nutrient</p>
Calcium Glycerophosphate	<p>The usage of calcium glycerophosphate as calcium should be no more than 1% of the foods.(However, in the case of Foods for special dietary uses and Health functional food, they should be in accordance with their food codes.)</p>	<p>Fortifying nutrient</p>
Calcium Hydroxide	<p>It should be used in accordance with Section II.2.1).</p>	<p>Acidity regulator Fortifying nutrient</p>
Calcium Hypochlorite	<p>Calcium Hypochlorite should be used for sterilization of foods such as fruits, vegetables, and etc and it should be removed before the final product is completed.</p>	<p>Sterilizing agent</p>
Calcium Lactate	<p>It should be used in accordance with Section II.2.1).</p>	<p>Acidity regulator Fortifying</p>

Food additive	Use Level	Major functional class
		nutrient
Calcium Oxide	It should be used in accordance with Section II.2.1).	Fortifying nutrient Acidity regulator
Calcium Pantothenate	The usage of Calcium Pantothenate as Calcium should be no more than 1% of foods. However, in the case of Foods for special dietary uses and Health functional food, they should be in accordance with their food codes.	Fortifying nutrient
Calcium Phosphate, Dibasic	The usage of Calcium Phosphate, dibasic as Calcium should be no more than 1% of foods. However, in the case of Foods for special dietary uses and Health functional food, they should be in accordance with their food codes.	Acidity regulator Fortifying nutrient Raising agent
Calcium Phosphate, Monobasic	The usage of Calcium Pantothenate, monobasic as Calcium should be no more than 1% of foods. However, in the case of Foods for special dietary uses and Health functional food, they should be in accordance with their food codes.	Acidity regulator Raising agent Fortifying nutrient
Calcium Phosphate, Tribasic	The usage of Calcium Pantothenate, tribasic as Calcium should be no more than 1% of foods. However, in the case of Foods for special dietary uses and Health functional food, they should be in accordance with their food codes.	Acidity regulator Fortifying nutrient Raising agent

Food additive	Use Level	Major functional class
Calcium Propionate	<p>Calcium Propionate should be used only for the following food items and the function. The usage as propionic acid should be</p> <ol style="list-style-type: none"> 1. Breads: no more than 2.5g/kg 2. Cheeses: no more than 3.0g/kg(if it is used with sorbic acid, calcium sorbate, or potassium sorbate, the sum of usage as propionic acid and sorbic acid should be no more than 3.0g/kg) 3. Jams: no more than 1.0g/kg(if it is used with sorbic acid, potassium sorbic, calcium sorbic, benzoic acid, potassium benzoate, calcium benzoate, sodium benzoate, methyl p-hydroxybenzoate, or ethyl p-hydroxybenzoate, the sum of usage as propionic acid, sorbic acid, benzoic acid, and p-hydroxybenzoic acid should be no more than 1.0g/kg). 	Preservative
Calcium 5'-Ribonucleotide	It should be used in accordance with Section II.2.1).	Fortifying nutrient Flavour enhancer

Food additive	Use Level	Major functional class
<p>Calcium silicate</p>	<p>Calcium silicate should be used only for anticaking agent, and filtering aid. However, if it is used for a filtering aid, it should be removed before the final product is completed. If it is used for a anticaking agent, it should be used only for the following food items and the usage should be</p> <ol style="list-style-type: none"> 1. Processed milk cream(only powder products for vending machine) : no more than 1%(if it is used with silicon dioxide or calcium silicate, the sum of usage should be no more than 1%) 2. Powdered milks(only for vending machine) : no more than 1%(if it is used with silicon dioxide or calcium silicate, the sum of usage should be no more than 1%) 3. Edible salts : no more than 2% (if it is used with silicon dioxide or calcium silicate, the sum of usage should be no more than 2%) 	<p>Anticaking agent Filter aid</p>

<p>Calcium sorbate</p>	<p>Calcium Sorbate should be used only for the following food items. The usage as sorbic acid should be</p> <ol style="list-style-type: none"> 1. Cheeses: no more than 3.0g/kg(if it is used with propionic acid, sodium propionate, or calcium propionate, the sum of usage as propionic acid and sorbic acid should be no more than 3.0g/kg) 2. Processed meat products(excluding seasoned meats, ground meat product, processed rib product, meat extract product), processed fish meat products, salted and fermented sea urchin, peanut butter, imitation cheese: no more than 2.0g/kg 3. Collagen casing: no more than 0.1g/kg 4. Salted and fermented seafood products(However, product which account for not more than 8% of salt only), korean-style <i>Doenjang</i>, <i>Doenjang</i>, <i>Gochujang</i>, mixed paste, <i>Chunjang</i>, <i>Cheonggukjang</i>(However, non-dried products only), dried fish and shellfish, boiled foods(ingredients for agricultural foods only), flour pastes, sauce: no more than 1.0g/kg(However, in the case of sauce, if it is used with Methyl p-Hydroxybenzoate or Ethyl p-Hydroxybenzoate, the sum of usage as sorbic acid and p-Hydroxybenzoic acid should be no more than 1.0g/kg, and the usage as p-Hydroxybenzoic acid should be no more than 0.2g/kg) 5. Aloe whole leaves(including Aloe gel) health functional food(However, in the case of using more than two kinds of health functional food materials, the usage applies proportion of the aloe whole leaves(including the aloe gel) health functional food content): no more than 1.0g/kg(if it is used with benzoic acid, sodium 	<p>Preservative</p>
-------------------------------	---	---------------------

benzoate, potassium benzoate or calcium benzoate, the sum of usage as sorbic acid and benzoic acid should be no more than 1.5g/kg and the usage as benzoic acid should be no more than 0.5g/kg)

6. Concentrated fruit juice, fruit/vegetable juice: no more than 1.0g/kg(if it is used with benzoic acid, sodium benzoate, potassium benzoate or calcium benzoate, the sum of usage as sorbic acid and benzoic acid should be no more than 1.0g/kg and the usage as benzoic acid should be no more than 0.6g/kg)
7. Carbonated beverages: no more than 0.5g/kg(If it is used with benzoic acid, sodium benzoate, potassium benzoate or calcium benzoate, the sum of usage as sorbic acid and benzoic acid should be no more than 0.6 g/kg, and the usage as sorbic acid should be no more than 0.5 g/kg)
8. Jams: no more than 1.0 g/kg(if it is used with benzoic acid, sodium benzoate, potassium benzoate, calcium benzoate, methyl p-hydroxybenzoate, ethyl p-hydroxybenzoate, propyl p-hydroxybenzoate, propionic acid, sodium propionate, or calcium propionate, the total usage of sorbic acid, benzoic acid, p-hydroxybenzoic acid, and propionic acid should be no more than 1.0 g/kg)
9. Dried fruits, tomato ketchup , Sugar-preserved food(excluding sugar-preserved dried foods): no more than 0.5g/kg.
10. Pickled food, **mayonnaise**: no more than 1.0g/kg(if it is used with benzoic acid, sodium benzoate, potassium benzoate or calcium benzoate, in that the total usage of benzoic acid and sorbic acid should be no more than 1.5 g/kg and the usage as benzoic

acid should be no more than 1.0 g/kg)

11. Fermented beverages(excluding pasteurized beverages): no more than 0.05g/kg.
12. Fruit wine, *Takju*(korean turbid rice wine), *Yakju*(korean clear rice wine): Not more than 0.2g/kg.
13. Margarine: no more than 1.0g/kg(if it is used with benzoic acid, sodium benzoate, potassium benzoate, or calcium benzoate, the total usage of sorbic acid and the benzoic acid should be no more than 2.0g/kg and the usage as benzoic acid should be no more than 1.0 g/kg)
14. Processed saccharide product(only syrup and paste): no more than 1.0g/kg
15. Spice preparation(excluding dried products): no more than 1.0g/kg
16. Health functional food(only liquid products, excluding aloe whole leaves(including Aloe gel) health functional food): no more than 2.0g/kg

Food additive	Use Level	Major functional class
Calcium Stearate	It should be used in accordance with Section II.2.1).	Fortifying nutrient Emulsifier
Calcium Stearoyl Lactylate	Calcium Stearoyl Lactylate should be used only for the following food items. 1. Breads and mixes for bread 2. Vegetable cream 3. Egg white 4. Confectionery(excluding <i>Hangwa</i> (korean traditional confectionery)) 5. Processed tuberous and corn vegetable product	Emulsifier
Calcium Sulfate	It should be used in accordance with Section II.2.1).	Tofu Firming agent Acidity regulator Fortifying nutrient
Candelilla Wax	It should be used in accordance with Section II.2.1).	Emulsifier Coating agent
Capric Acid	It should be used in accordance with Section II.2.1).	manufacturing solvent
Caprylic acid	It should be used in accordance with Section II.2.1).	manufacturing solvent

Food additive	Use Level	Major functional class
Caramel Color	<p>Caramel color should not be used in the food items listed below.</p> <ol style="list-style-type: none"> 1. Natural food[meat, fishes and shellfishes, fruits, vegetables, algae, Legume vegetables and pulses, and their simply processed food(peeled, cut, and etc.)] 2. Teas(except for Solid tea, and liquid tea that is diluted for drinking) 3. Teas containing ginseng or red ginseng components 4. Coffee 5. Hot pepper powder, shredded hot pepper 6. <i>Kimchi</i> products 7. <i>Gochujang</i>(hot pepper soy paste), seasoned hot pepper soy paste 8. Health supplement food containing ginseng or red ginseng components 	Colour
Carbon Dioxide	It should be used in accordance with Section II.2.1).	Propellant Packaging gas

Food additive	Use Level	Major functional class
Carmines	<p>Carmines should not be used in the food items listed below.</p> <ol style="list-style-type: none"> 1. Natural food[meat, fishes and shellfishes, fruits, vegetables, algae, Legume vegetables and pulses, and their simply processed food(peeled, cut, and etc.)] 2. Teas 3. Coffee 4. Hot pepper powder, shredded hot pepper 5. <i>Kimchi</i> products 6. <i>Gochujang</i>(hot pepper soy paste), seasoned hot pepper soy paste 7. Vinegars 8. Spice Products(only the products containing hot pepper or hot pepper powder) 	Colour
Carnauba Wax	It should be used in accordance with Section II.2.1).	Emulsifier Thickener Stabilizer
L-Carnitine	It should be used in accordance with Section II.2.1).	Fortifying nutrient
Carotene	<p>Carotene should not be used in the food items listed below.</p> <ol style="list-style-type: none"> 1. Natural food[meat, fishes and shellfishes, fruits, vegetables, algae, Legume vegetables and pulses, and their simply processed food(peeled, cut, and etc.)] 2. Teas 3. Coffee 4. Hot pepper powder, shredded hot pepper 5. <i>Kimchi</i> products 6. <i>Gochujang</i>(hot pepper soy paste), seasoned hot pepper soy paste 	Colour Fortifying nutrient

Food additive	Use Level	Major functional class
	7. Vinegars	
β-Carotene	<p>β-Carotene should not be used in the food items listed below.</p> <ol style="list-style-type: none"> 1. Natural food[meat, fishes and shellfishes, fruits, vegetables, algae, Legume vegetables and pulses, and their simply processed food(peeled, cut, and etc.)] 2. Teas 3. Coffee 4. Hot pepper powder, shredded hot pepper 5. <i>Kimchi</i> products 6. <i>Gochujang</i>(hot pepper soy paste), seasoned hot pepper soy paste 7. Vinegars 	Colour Fortifying nutrient
Carrageenan	It should be used in accordance with Section II.2.1).	Emulsifier Thickener Stabilizer

Food additive	Use Level	Major functional class
Carthamus Red	<p>Carthamus red should not be used in the food items listed below.</p> <ol style="list-style-type: none"> 1. Natural food[meat, fishes and shellfishes, fruits, vegetables, algae, Legume vegetables and pulses, and their simply processed food(peeled, cut, and etc.)] 2. Teas 3. Coffee 4. Hot pepper powder, shredded hot pepper 5. <i>Kimchi</i> products 6. <i>Gochujang</i>(hot pepper soy paste), seasoned hot pepper soy paste 7. Vinegars 	Colour
Carthamus Yellow	<p>Carthamus yellow should not be used in the food items listed below.</p> <ol style="list-style-type: none"> 1. Natural food[meat, fishes and shellfishes, fruits, vegetables, algae, Legume vegetables and pulses, and their simply processed food(peeled, cut, and etc.)] 2. Teas 3. Coffee 4. Hot pepper powder, shredded hot pepper 5. <i>Kimchi</i> products 6. <i>Gochujang</i>(hot pepper soy paste), seasoned hot pepper soy paste 7. Vinegars 	Colour
Casein	It should be used in accordance with Section II.2.1).	Emulsifier Thickener Stabilizer

Food additive	Use Level	Major functional class
Castor oil	Castor oil should only be used for the following food items and the usage is, 1. Candies: no more than 0.5g/kg(for a release agent) 2. Tablets(for a coating agent)	Coating agent Releasing agent
Catalase	It should be used in accordance with Section II.2.1).	Enzyme preparations
Cellulase	It should be used in accordance with Section II.2.1).	Enzyme preparations
Cellulose, Microcrystalline	It should be used in accordance with Section II.2.1).	Thickener Stabilizer Anticaking agent
Cellulose, Powdered	It should be used in accordance with Section II.2.1).	Thickener Stabilizer Anticaking agent
Chitin	It should be used in accordance with Section II.2.1).	Thickener Stabilizer
Chitosan	It should be used in accordance with Section II.2.1).	Thickener Stabilizer
Chitosanase	It should be used in accordance with Section II.2.1).	Enzyme preparations
Chlorine	Chlorine should be used only for the following food item and the usage should be 1. Wheat flour products: no more than 2.5g/kg	Flour treatment agent

Food additive	Use Level	Major functional class
Chlorine Dioxide	<p>Chlorine Dioxide should be used only for the following food items or function. The usage should be</p> <ol style="list-style-type: none"> 1. Wheat flour for breads: no more than 30mg/kg(for a chlorine dioxide) 2. For pasteurization of food such as fruits, vegetables, and etc. and it should be removed before the final product is completed(for a chlorine dioxide solution). 	<p>Flour treatment agent Sterilizing agent</p>
Chlorophyll	<p>Chlorophyll should not be used in the food items listed below.</p> <ol style="list-style-type: none"> 1. Natural food[meat, fishes and shellfishes, fruits, vegetables, algae, Legume vegetables and pulses, and their simply processed food(peeled, cut, and etc.)] 2. Teas 3. Coffee 4. Hot pepper powder, shredded hot pepper 5. <i>Kimchi</i> products 6. <i>Gochujang</i>(hot pepper soy paste), seasoned hot pepper soy paste 7. Vinegars 	<p>Colour</p>
Choline Bitartrate	<p>It should be used in accordance with Section II.2.1).</p>	<p>Fortifying nutrient</p>
Choline chloride	<p>It should be used in accordance with Section II.2.1).</p>	<p>Fortifying nutrient</p>
Chromic chloride	<p>Chromic chloride should be used only for the following food items</p> <ol style="list-style-type: none"> 1. Foods for special medical purposes 2. Health functional food 	<p>Fortifying nutrient</p>
Cinnamaldehyde	<p>Cinnamaldehyde should be used for flavorings only.</p>	<p>Flavouring agent</p>

Food additive	Use Level	Major functional class
Cinnamic Acid	Cinnamic Acid should be used for flavorings only.	Flavouring agent
Cinnamyl Acetate	Cinnamyl Acetate should be used for flavorings only.	Flavouring agent
Cinnamyl Alcohol	Cinnamyl Alcohol should be used for flavorings only.	Flavouring agent
Citral	Citral should be used for flavorings only.	Flavouring agent
Citric Acid	It should be used in accordance with Section II.2.1).	Acidity regulator
Citronellal	Citronellal should be used for flavorings only.	Flavouring agent
Citronellol	Citronellol should be used for flavorings only.	Flavouring agent
Citronellyl Acetate	Citronellyl Acetate should be used for flavorings only.	Flavouring agent
Citronellyl Formate	Citronellyl Formate should be used for flavorings only.	Flavouring agent

Food additive	Use Level	Major functional class
Cochineal Extract	<p>Cochineal Extract should not be used in the food items listed below.</p> <ol style="list-style-type: none"> 1. Natural food[meat, fishes and shellfishes, fruits, vegetables, algae, Legume vegetables and pulses, and their simply processed food(peeled, cut, and etc.)] 2. Teas 3. Coffee 4. Hot pepper powder, shredded hot pepper 5. <i>Kimchi</i> products 6. <i>Gochujang</i>(hot pepper soy paste), seasoned hot pepper soy paste 7. Vinegars 8. Spice Products(only the products containing hot pepper or hot pepper powder) 	Colour
Copper Chlorophyll	<p>Copper Chlorophyll should be used only for the following food items. The usage as copper should be</p> <ol style="list-style-type: none"> 1. Kelp(anhydrous form): no more than 0.15g/kg 2. Preserved vegetables or fruits: no more than 0.1g/kg 3. Chewing gum and candies: no more than 0.05g/kg 4. Agar in canned green pea product: no more than 0.0004g/kg 	Colour

Food additive	Use Level	Major functional class
Copper Gluconate	Copper Gluconate should be used only for the following food items. <ol style="list-style-type: none"> 1. Cereals 2. Milk formulas, infant formulas, follow-up formulas, cereal based food for infants/young children, other foods for infants/young children 3. Food for special medical purposes 4. Weight control formulas 5. Health functional food 	Fortifying nutrient
Cross-Linked Sodium Carboxymethyl Cellulose	Cross-Linked Sodium Carboxymethyl Cellulose should be used only for health functional food(tablet or its coating, capsule only) and capsules for a coating agent.	Coating agent
Crude Magnesium Chloride(Sea Water)	Crude Magnesium Chloride(Sea Water) should be used only for the following food item. <ol style="list-style-type: none"> 1. Soybean curds for a firming agent 	Tofu Firming agent
Cupric Sulfate	Cupric Sulfate should be used only for the food items. However, in case of grape wines, the residual amount as copper should be less than <ol style="list-style-type: none"> 1. Grape wines : 1mg/kg 2. Cereals 3. Milk formulas, infant formulas, follow-up formulas, cereal based food for infants/young children, other foods for infant/young children 4. Food for special medical purposes 5. Weight control formulas 6. Health functional food 	Fortifying nutrient manufacturing solvent

Food additive	Use Level	Major functional class
Curcumin	<p>Curmumin should not be used in the food items listed below.</p> <ol style="list-style-type: none"> 1. Natural food[meat, fishes and shellfishes, fruits, vegetables, algae, Legume vegetables and pulses, and their simply processed food(peeled, cut, and etc.)] 2. Teas 3. Coffee 4. Hot pepper powder, shredded hot pepper 5. <i>Kimchi</i> products 6. <i>Gochujang</i>(hot pepper soy paste), seasoned hot pepper soy paste 7. Vinegars 	Colour
Curdlan	It should be used in accordance with Section II.2.1).	Thickener Stabilizer
Cyclodextrin	It should be used in accordance with Section II.2.1).	Stabilizer
Cyclodextrin Syrup	It should be used in accordance with Section II.2.1).	Stabilizer
L-Cysteine Monohydrochloride	<p>L-Cystein Monohydrochloride should be used only for the following food items or function.</p> <ol style="list-style-type: none"> 1. Wheat flour products 2. Fruit juice 3. Breads and mixes for breads 4. For flavorings 	Flour treatment agent Fortifying nutrient Flavouring agent
L-Cystine	It should be used in accordance with Section II.2.1).	Fortifying nutrient

Food additive	Use Level	Major functional class
5'-Cytidylic acid	5'-Cytidylic acid should be used for the following food items only and the usage is, 1. Milk formulas, infant formulas, follow-up formulas, cereal formulas for infants/young children, other foods for infants/young children, formulas for infants/young children with milk protein allergy, special formulas for infants/young children: no more than 0.125g/kg	Fortifying nutrient
Dammar Gum	It should be used in accordance with Section II.2.1).	Coating agent Thickener Stabilizer
5'-Deaminase	It should be used in accordance with Section II.2.1).	Enzyme preparations
Decanal	Decanal should be used for flavorings only.	Flavouring agent
Decanol	Decanol should be used for flavorings only.	Flavouring agent
Dextran	It should be used in accordance with Section II.2.1).	Thickener Stabilizer
Dextranase	It should be used in accordance with Section II.2.1).	
Diastase(Diastatic Power, DP)	It should be used in accordance with Section II.2.1).	Enzyme preparations

Food additive	Use Level	Major functional class
Diatomaceous Earth	Diatomaceous earth(dried, calcined, flux-calcined) should be used only for a filtering aid(filtering, discoloring, deodorizing, refining, and etc.) in food manufacturing or processing. However, it should be removed before the final product is completed. The residual amount should be no more than 0.5%(if it is used with kaolin, bentonite, acid clay, talc, perlite, activated carbon, and other insoluble minerals, the sum of the residues should be no more than 0.5%).	Filter aid
Dibenzoyl Thiamine	It should be used in accordance with Section II.2.1).	Fortifying nutrient
Dibenzoyl Thiamine Hydrochloride	It should be used in accordance with Section II.2.1).	Fortifying nutrient
Diluted Benzoyl Peroxide	Diluted Benzoyl Peroxide should be used only for the following food item. The usage should be 1. Wheat flour products: no more than 0.3g/kg	Flour treatment agent
Disodium 5'-Cytidylate	Disodium 5'-Cytidylate should only be used for the following food items. The usage of Disodium 5'-Cytidylate should be 1. Milk formulas, infant formulas, follow-up formulas, cereal formulas for infants/young children, other foods for infants/young children, formulas for infants/young children with milk protein allergy, special formulas for infants/young children : no more than 0.142g/kg	Fortifying nutrient
Disodium Dihydrogen Pyrophosphate	It should be used in accordance with Section II.2.1).	Acidity regulator Raising agent

Food additive	Use Level	Major functional class
<p>Disodium Ethylenediamine-tetraacetate</p>	<p>Disodium Ethylenediaminetetraacetate should be used only for the following food items. The usage as anhydrous disodium ethylenediaminetetraacetate should be</p> <ol style="list-style-type: none"> 1. Sauce, mayonnaise: no more than 0.075g/kg(if it is used with EDTA disodium, the sum of usage as anhydrous EDTA disodium should be 0.075g/kg) 2. Canned or bottled foods: no more than 0.25g/kg(if it is used with EDTA disodium, the sum of usage as anhydrous EDTA disodium should be 0.025g/kg) 3. Beverages(only canned or bottled products, and excluding teas and coffee): no more than 0.035g/kg(if it is used with EDTA disodium, the sum of usage as anhydrous EDTA disodium should be 0.035g/kg) 4. Margarine: no more than 0.1g/kg(if it is used with EDTA disodium, the sum of usage as anhydrous EDTA disodium should be 0.1g/kg) 5. Vinegar-pickled cucumber and vinegar-pickled cabbage: no more than 0.22g/kg(if it is used with EDTA disodium, the sum of usage as anhydrous EDTA disodium should be 0.22g/kg) 6. Dried fruits(only bananas): no more than 0.265g/kg(if it is used with EDTA disodium, the sum of usage as anhydrous EDTA disodium should be 0.265g/kg) 7. Processed tuberous and corn vegetable product(only frozen potatoes): no more than 0.365g/kg(if it is used with EDTA disodium, the sum of usage as anhydrous EDTA disodium 	<p>Antioxidant</p>

Food additive	Use Level	Major functional class
	<p>should be 0.365g/kg)</p> <p>8. Peanut butter: no more than 0.1g/kg(if it is used with EDTA disodium, the sum of usage as anhydrous EDTA disodium should be 0.1g/kg)</p>	

Food additive	Use Level	Major functional class
Disodium Glycyrrhizinate	Disodium Glycyrrhizinate should be used only for following food items. 1. Korean-style doenjang(soybean paste), Doenjang(soybean paste) 2. Korean-style soy sauce, brewed soy sauce, acid-hydrolyzed soy sauce, enzyme-hydrolyzed soy sauce, blended soy sauce	Sweetener
Disodium 5'-Guanylate	It should be used in accordance with Section II.2.1).	Fortifying nutrient Flavour enhancer
Disodium 5'-inosinate	It should be used in accordance with Section II.2.1).	Fortifying nutrient Flavour enhancer
Disodium 5'-Ribonucleotide	It should be used in accordance with Section II.2.1).	Fortifying nutrient Flavour enhancer
Disodium Succinate	It should be used in accordance with Section II.2.1).	Acidity regulator Flavour enhancer
Disodium DL-Tartrate	It should be used in accordance with Section II.2.1).	Acidity regulator
Disodium L-Tartrate	It should be used in accordance with Section II.2.1).	Acidity regulator Fortifying nutrient

Food additive	Use Level	Major functional class
Disodium 5'-Uridylate	Disodium 5'-Uridylate should be used only for the following food items. The usage should be <ol style="list-style-type: none"> 1. Milk formulas, infant formulas, follow-up formulas, cereal formulas for infants/young children, other foods for infants/young children, formulas for infants/young children with milk protein allergy, special formulas for infants/young children : no more than 0.099g/kg 2. Food for patients: no more than 8g/kg 	fortifying nutrient
Dry Formed Vitamin A	It should be used in accordance with Section II.2.1).	Fortifying nutrient
Enzymatically Decomposed Apple Extract	It should be used in accordance with Section II.2.1).	Antioxidant
Enzymatically Decomposed Lecithin	It should be used in accordance with Section II.2.1).	Emulsifier
Enzymatically Modified Hesperidine	It should be used in accordance with Section II.2.1).	Fortifying nutrient
Enzymatically Modified Rutin	It should be used in accordance with Section II.2.1).	Antioxidant
Enzymatically Modified Stevia	Enzymatically Modified Stevia should not be used in the food items listed below. <ol style="list-style-type: none"> 1. Sugars 2. Glucose 3. Starch syrup 4. Honeys 	Sweetener
Erythorbic Acid	Erythorbic Acid should be only used for a antioxidant.	Antioxidant
Erythritol	It should be used in accordance with Section II.2.1).	Flavour enhancer Sweetener

Food additive	Use Level	Major functional class
		Humectant
Ester Gum	Ester gum should be used only for the following food items or function. 1. For a gum base 2. Carbonated beverages, other beverages	Gum base Stabilizer
Ethyl Acetate	Ethyl Acetate should be used only for the following food items or function. 1. For flavorings 2. For a manufacturing solvent of polyvinyl acetate 3. Extracting or separating functional material of health functional food: no more than 0.005g/kg(as the sum of the residues)	Extraction solvent Flavouring agent
Ethyl Acetoacetate	Ethyl Acetoacetate should be used for flavorings only.	Flavouring agent
Ethyl Butyrate	Ethyl Butyrate should be used for flavorings only.	Flavouring agent
Ethyl cellulose, Modified Cellulose	It should be used in accordance with Section II.2.1).	Thickener Stabilizer
Ethyl Cinnamate	Ethyl Cinnamate should be used for flavorings only.	Flavouring agent
Ethyl Decanoate	Ethyl Decanoate should be used for flavorings only.	Flavouring agent
Ethyl Heptanoate	Ethyl Heptanoate should be used for flavorings only.	Flavouring agent
Ethyl Hexanoate	Ethyl Hexanoate should be used for flavorings only.	Flavouring agent

<p>Ethyl p-Hydroxybenzoate</p>	<p>Ethyl p-Hydroxybenzoate should be used only for the following food items. The usage of Ethyl p-Hydroxybenzoate as p-hydroxybenzoic acid should be</p> <ol style="list-style-type: none"> 1. Capsules : no more than 1.0g/kg 2. Jams: no more than 1.0g/kg(if it is used with sorbic acid, potassium sorbate, calcium sorbate, benzoic acid, potassium benzoate, calcium benzoate, sodium benzoate, ethyl p-hydroxybenzoate, propionic acid, sodium propionate, and calcium propionate, the sum of usage as sorbic acid, benzoic acid, p-hydroxybenzoic acid, and propionic acid should be no more than 1.0g/kg) 3. Mango chutney: no more than 0.25g/kg(if it is used with sodium benzoate , potassium benzoate, calcium benzoate and ethyl p-hydroxybenzoate, the sum of usage as benzoic acid and p-hydroxybenzoic acid should be no more than 0.25g/kg) 4. Korean-style soy sauce, Brewed soy sauce, Acid-hydrolyzed soy sauce, Enzyme-hydrolyzed soy sauce, Blended soy sauce : no more than 0.25g/kg(if it is used with benzoic acid, sodium benzoate, potassium benzoate, calcium benzoate, the sum of usage as benzoic acid and p-hydroxybenzoic acid should be no more than 0.6g/kg, and the usage as p-hydroxybenzoic acid should be no more than 0.25g/kg) 5. Vinegars : no more than 0.1g/L. 6. Other beverages(excluding powder products), Ginseng/red ginseng beverages: no more than 0.1g/kg(if it is used with benzoic acid, sodium benzoate, potassium benzoate, calcium benzoate, the sum of usage as benzoic acid and p-hydroxybenzoic acid should be no more than 0.6g/kg, and the usage as p- 	<p>Preservative</p>
---------------------------------------	--	---------------------

hydroxybenzoic acid should be no more than 0.1g/kg)

7. Sauce : no more than 0.2g/kg(if it is used with sorbic acid, potassium sorbate or calcium sorbate, the sum of usage as p-hydroxybenzoic acid and sorbic acid should be no more than 1.0g/kg, and the usage as p-hydroxybenzoic acid should be no more than 0.2g/kg)

8. Fruits(peels only) : no more than 0.012g/kg

9. Vegetables(peels only) : no more than 0.012g/kg

Food additive	Use Level	Major functional class
Ethyl isovalerate	Ethyl Isovalerate should be used for flavorings only.	Flavouring agent
Ethyl Octanoate	Ethyl Octanoate should be used for flavorings only.	Flavouring agent
Ethyl Phenylacetate	Ethyl Phenylacetate should be used for flavorings only.	Flavouring agent
Ethyl Propionate	Ethyl Propionate should be used for flavorings only.	Flavouring agent
Ethyl Vanillin	Ethyl vanillin should be used for flavorings only.	Flavouring agent
Eucalyptol	Eucalyptol should be used for flavorings only.	Flavouring agent
Eugenol	Eugenol should be used for flavorings only.	Flavouring agent
Exomaltotetrahydrolase	It should be used in accordance with Section II.2.1).	Enzyme preparations
Ferric Ammonium Citrate	It should be used in accordance with Section II.2.1).	Fortifying nutrient
Ferric Chloride	It should be used in accordance with Section II.2.1).	Fortifying nutrient
Ferric Citrate	It should be used in accordance with Section II.2.1).	Fortifying nutrient

Food additive	Use Level	Major functional class
Ferric Phosphate	It should be used in accordance with Section II.2.1).	Fortifying nutrient
Ferric Pyrophosphate	It should be used in accordance with Section II.2.1).	Fortifying nutrient
Ferrous Fumarate	It should be used in accordance with Section II.2.1).	Fortifying nutrient
Ferrous Gluconate	<p>Ferrous Guconate should be used only for the following food items. The usage as ferrous ion should be</p> <ol style="list-style-type: none"> 1. Processed olive products : no more than 0.15g/kg 2. Milk formulas, infant formulas, follow-up formulas, cereal formulas for infants/young children, other foods for infants/young children, formulas for infants/young children with milk protein allergy, special formulas for infants/young children 3. Health functional food 	Acidity regulator Fortifying nutrient
Ferrous Lactate	It should be used in accordance with Section II.2.1).	Acidity regulator Fortifying nutrient
Ferrous Sulfate	It should be used in accordance with Section II.2.1).	Fortifying nutrient
Ferulic Acid	It should be used in accordance with Section II.2.1).	Antioxidant
Folic Acid	It should be used in accordance with Section II.2.1).	Fortifying nutrient

<p>Food Blue No.1</p>	<p>Food Blue No. 1 should be used only for the following food items. The usage should be</p> <ol style="list-style-type: none"> 1. Confectionery: no more than 0.2g/kg 2. Candies and chewing gum: no more than 0.3g/kg 3. Frozen confectionery products: no more than 0.15g/kg 4. Breads: no more than 0.2g/kg 5. Rice cakes: no more than 0.15g/kg 6. Dumpling: no more than 0.1g/kg 7. Other processed cocoa product and chocolates: no more than 0.1g/kg 8. Other jam: no more than 0.25g/kg 9. Other sugar, other taffies, and sugar syrups: no more than 0.3 g/kg 10. Sausages and fish sausage: no more than 0.1g/kg 11. Fruit/vegetable beverages, carbonated beverages, other beverages: no more than 0.1g/kg(However, the product that is to be diluted before drinking is based on the diluted form) 12. Spices products(only processed horseradish products and processed mustard products): no more than 0.1g/kg 13. Sauce: no more than 0.1g/kg 14. Pickled food products(only Hermetic sealing, heat-pasteurization or sterilization pickled food products, but excluding pickled radish): no more than 0.5 g/kg 15. Alcoholic beverages(excluding <i>Takju</i>, <i>Yakju</i>, <i>Soju</i>, and <i>Cheongju</i> which is not added to spirits): no more than 0.2g/kg 16. Vegetable cream: no more than 0.1g/kg 17. Ready-to-eat foods : no more than 0.05g/kg 18. Processed cereal product: no more than 0.3g/kg 19. Processed pulse product and processed 	<p>Colour</p>
------------------------------	--	---------------

tuberous and corn vegetable product: no more than 0.2g/kg

20. Processed starch product: no more than 0.15g/kg

21. Other processed edible fat and oil product, processed saccharide product, other processed fishery product, and other processed product: no more than 0.5g/kg

22. Health functional food(only coating of tablet or capsule) and capsules: no more than 0.3g/kg

23. Ice creams, ice cream mixes: no more than 0.15g/kg

<p>Food Blue No.1 Aluminium Lake</p>	<p>Food Blue No.1 Aluminium Lake should be used only for the following food items. The usage as a Food Blue No.1 should be</p> <ol style="list-style-type: none"> 1. Confectionery: no more than 0.2g/kg 2. Candies and chewing gum: no more than 0.3g/kg 3. Frozen confectionery products: no more than 0.15g/kg 4. Breads: no more than 0.2g/kg 5. Rice cakes: no more than 0.15g/kg 6. Dumpling: no more than 0.1g/kg 7. Other processed cocoa product and chocolates: no more than 0.1g/kg 8. Other jam: no more than 0.25g/kg 9. Other sugar, other taffies, and sugar syrups: no more than 0.3 g/kg 10. Sausages and fish sausage: no more than 0.1g/kg 11. Fruit/vegetable beverages, carbonated beverages, other beverages: no more than 0.1g/kg(However, the product that is to be diluted before drinking is based on the diluted form) 12. Spices products(only processed horseradish products and processed mustard products): no more than 0.1g/kg 13. Sauce: no more than 0.1g/kg 14. Pickled food products(only Hermetic sealing, heat-pasteurization or sterilization pickled food products, but excluding pickled radish): no more than 0.5 g/kg 15. Alcoholic beverages(excluding <i>Takju</i>, <i>Yakju</i>, <i>Soju</i>, and <i>Cheongju</i> which is not added to spirits): no more than 0.2g/kg 16. Vegetable cream: no more than 0.1g/kg 17. Ready-to-eat foods : no more than 0.05g/kg 18. Processed cereal product: no more than 0.3g/kg 	<p>Colour</p>
---	---	---------------

19. Processed pulse product and processed tuberous and corn vegetable product: no more than 0.2g/kg
20. Processed starch product: no more than 0.15g/kg
21. Other processed edible fat and oil product, processed saccharide product, other processed fishery product, and other processed product: no more than 0.5g/kg
22. Health functional food(only coating of tablet or capsule) and capsules: no more than 0.3g/kg
23. Ice creams, ice cream mixes: no more than 0.15g/kg

<p>Food Blue No.2</p>	<p>Food Blue No.2 should be used only for the following food items. The usage should be</p> <ol style="list-style-type: none"> 1. Confectionery: no more than 0.2g/kg 2. Candies and chewing gum: no more than 0.3g/kg 3. Frozen confectionery products: no more than 0.15g/kg 4. Breads: no more than 0.2g/kg 5. Rice cakes: no more than 0.15g/kg 6. Other processed cocoa product and chocolates: no more than 0.45g/kg 7. Other jam, Other sugar: no more than 0.3g/kg 8. Sausages: no more than 0.1 g/kg 9. Fish sausage: no more than 0.3g/kg 10. Fruit/vegetable beverages and other beverages: no more than 0.1g/kg(However, the product that is to be diluted before drinking is based on the diluted form) 11. Spices products(only processed horseradish products and processed mustard products): no more than 0.3g/kg 12. Pickled food products(only Hermetic sealing, heat-pasteurization or sterilization pickled food products, but excluding pickled radish): no more than 0.3g/kg 13. Alcoholic beverages(excluding <i>Takju</i>, <i>Yakju</i>, <i>Soju</i>, and <i>Cheongju</i> which is not added to spirits): no more than 0.3g/kg 14. Processed cereal product: no more than 0.2g/kg 15. Processed saccharide product: no more than 0.3g/kg 16. Other processed product: no more than 0.45g/kg 17. Health functional food(only coating of tablet or capsule) and capsules: no more than 0.3g/kg 18. Ice creams, ice cream mixes: no more than 	<p>Colour</p>
------------------------------	---	---------------

0.15g/kg

Food additive	Use Level	Major functional class
<p>Food Blue No.2 Aluminium Lake</p>	<p>Food Blue No.2 Aluminium Lake should be used only for the following food items. The usage as a Food Blue No.2 should be</p> <ol style="list-style-type: none"> 1. Confectionery: no more than 0.2g/kg 2. Candies and chewing gum: no more than 0.3g/kg 3. Frozen confectionery products: no more than 0.15g/kg 4. Breads: no more than 0.2g/kg 5. Rice cakes: no more than 0.15g/kg 6. Other processed cocoa product and chocolates: no more than 0.45g/kg 7. Other jam, Other sugar: no more than 0.3g/kg 8. Sausages: no more than 0.1 g/kg 9. Fish sausage: no more than 0.3g/kg 10. Fruit/vegetable beverages and other beverages: no more than 0.1g/kg(However, the product that is to be diluted before drinking is based on the diluted form) 11. Spices products(only processed horseradish products and processed mustard products): no more than 0.3g/kg 12. Pickled food products(only Hermetic sealing, heat-pasteurization or sterilization pickled food products, but excluding pickled radish): no more than 0.3g/kg 13. Alcoholic beverages(excluding <i>Takju</i>, <i>Yakju</i>, <i>Soju</i>, and <i>Cheongju</i> which is not added to spirits): no more than 0.3g/kg 14. Processed cereal product: no more than 0.2g/kg 15. Processed saccharide product: no more than 0.3g/kg 16. Other processed product: no more than 	<p>Colour</p>

Food additive	Use Level	Major functional class
	<p>0.45g/kg</p> <p>17. Health functional food(only coating of tablet or capsule) and capsules: no more than 0.3g/kg</p> <p>18. Ice creams, ice cream mixes: no more than 0.15g/kg</p>	

Food additive	Use Level	Major functional class
<p>Food Green No.3</p>	<p>Food Green No.3 should be used only for the following food items. The usage should be</p> <ol style="list-style-type: none"> 1. Confectionery: no more than 0.1g/kg 2. Candies: no more than 0.4g/kg 3. Breads and Rice cakes: no more than 0.1g/kg 4. Chocolates: no more than 0.6g/kg 5. Other jam: no more than 0.4g/kg 6. Sausages and fish sausage: no more than 0.1g/kg 7. Fruit/vegetable beverages, carbonated beverages, and other beverages: no more than 0.1g/kg(However, the product that is to be diluted before drinking is based on the diluted form) 8. Spices products(only processed horseradish products and processed mustard products): no more than 0.1g/kg 9. Pickled food products(only Hermetic sealing, heat-pasteurization or sterilization pickled food products, but excluding pickled radish): no more than 0.3g/kg 10. Alcoholic beverages(excluding <i>Takju</i>, <i>Yakju</i>, <i>Soju</i>, and <i>Cheongju</i> which is not added to spirits): no more than 0.1g/kg 11. Processed cereal product, processed saccharide product, and other processed fishery product: no more than 0.1g/kg 12. Health functional food(only coating of tablet or capsule) and capsules: no more than 0.6g/kg 13. Ice creams, ice cream mixes: no more than 0.1g/kg 	<p>Colour</p>

Food additive	Use Level	Major functional class
<p>Food Green No.3 Aluminium Lake</p>	<p>Food Green No.3 Aluminium Lake should be used only for the following food items. The usage as a Food Green No.3 should be</p> <ol style="list-style-type: none"> 1. Confectionery: no more than 0.1g/kg 2. Candies: no more than 0.4g/kg 3. Breads and Rice cakes: no more than 0.1g/kg 4. Chocolates: no more than 0.6g/kg 5. Other jam: no more than 0.4g/kg 6. Sausages and fish sausage: no more than 0.1g/kg 7. Fruit/vegetable beverages, carbonated beverages, and other beverages: no more than 0.1g/kg(However, the product that is to be diluted before drinking is based on the diluted form) 8. Spices products(only processed horseradish products and processed mustard products): no more than 0.1g/kg 9. Pickled food products(only Hermetic sealing, heat-pasteurization or sterilization pickled food products, but excluding pickled radish): no more than 0.3g/kg 10. Alcoholic beverages(excluding <i>Takju</i>, <i>Yakju</i>, <i>Soju</i>, and <i>Cheongju</i> which is not added to spirits): no more than 0.1g/kg 11. Processed cereal product, processed saccharide product, and other processed fishery product: no more than 0.1g/kg 12. Health functional food(only coating of tablet or capsule) and capsules: no more than 0.6g/kg 13. Ice creams, ice cream mixes: no more than 0.1g/kg 	<p>Colour</p>

Food additive	Use Level	Major functional class
Food Red No.102	<p>Food Red No.102 should be used only for the following food items. The usage should be</p> <ol style="list-style-type: none"> 1. Confectionery(only <i>Hangwa</i>(korean traditional confectionery)): no more than 0.2g/kg 2. Chewing gum: no more than 0.3g/kg 3. Rice cakes: no more than 0.05g/kg 4. Dumpling: no more than 0.5g/kg 5. Other processed cocoa product: no more than 0.3g/kg 6. Sausages: no more than 0.05g/kg 7. Beverage base: no more than 0.05g/kg(However, the product that is to be diluted before drinking is based on the diluted form) 8. Spices products(only processed horseradish products and processed mustard products): no more than 0.5g/kg 9. Salted-fermented seafood products(only <i>myeongnan-jeot</i>): no more than 0.5g/kg 10. Pickled food products(only Hermetic sealing, heat-pasteurization or sterilization pickled food products, but excluding pickled radish): no more than 0.5g/kg 11. Alcoholic beverages(excluding <i>Takju</i>, <i>Yakju</i>, <i>Soju</i>, and <i>Cheongju</i> which is not added to spirits): no more than 0.2g/kg 12. Processed pulse product and processed tuberous and corn vegetable product: no more than 0.2g/kg 13. Processed saccharide product: no more than 0.3g/kg 14. Other processed fishery product and other processed product: no more than 0.5g/kg 15. Health functional food(only coating of tablet or capsule) and capsules: no more than 0.3g/kg 	Colour

Food additive	Use Level	Major functional class
<p>Food Red No.2</p>	<p>Food Red No.2 should be used only for the following food items. The usage should be</p> <ol style="list-style-type: none"> 1. Confectionery(only <i>Hangwa</i>(korean traditional confectionery)) and chewing gum: no more than 0.3g/kg 2. Rice cakes: no more than 0.3g/kg 3. Sausages: no more than 0.05g/kg 4. Beverage base: no more than 0.3g/kg(However, the product that is to be diluted before drinking is based on the diluted form) 5. Spices products(only processed horseradish products and processed mustard products): no more than 0.5g/kg 6. Salted-fermented seafood products(only <i>myeongnan-jeot</i>): no more than 0.03g/kg 7. Pickled food products(only Hermetic sealing, heat-pasteurization or sterilization pickled food products, but excluding pickled radish): no more than 0.5g/kg 8. Alcoholic beverages(excluding <i>Takju, Yakju, Soju,</i> and <i>Cheongju</i> which is not added to spirits): no more than 0.1g/kg 9. Vegetable cream: no more than 0.5g/kg 10. Ready-to-eat foods: no more than 0.3g/kg 11. Processed cereal product, processed starch product and processed saccharide product: no more than 0.3g/kg 12. Other processed fishery product and other processed product: no more than 0.5g/kg 13. Health functional food(only coating of tablet or capsule) and capsules: no more than 0.3g/kg 	<p>Colour</p>

Food additive	Use Level	Major functional class
<p>Food Red No.2 Aluminum Lake</p>	<p>Food Red No.2 Aluminum Lake should be used only for the following food items. The usage as a Food Red No.2 should be</p> <ol style="list-style-type: none"> 1. Confectionery(only <i>Hangwa</i>(korean traditional confectionery)) and chewing gum: no more than 0.3g/kg 2. Rice cakes: no more than 0.3g/kg 3. Sausages: no more than 0.05g/kg 4. Beverage base: no more than 0.3g/kg(However, the product that is to be diluted before drinking is based on the diluted form) 5. Spices products(only processed horseradish products and processed mustard products): no more than 0.5g/kg 6. Salted-fermented seafood products(only <i>myeongnan-jeot</i>): no more than 0.03g/kg 7. Pickled food products(only Hermetic sealing, heat-pasteurization or sterilization pickled food products, but excluding pickled radish): no more than 0.5g/kg 8. Alcoholic beverages(excluding <i>Takju</i>, <i>Yakju</i>, <i>Soju</i>, and <i>Cheongju</i> which is not added to spirits): no more than 0.1g/kg 9. Vegetable cream: no more than 0.5g/kg 10. Ready-to-eat foods: no more than 0.3g/kg 11. Processed cereal product, processed starch product and processed saccharide product: no more than 0.3g/kg 12. Other processed fishery product and other processed product: no more than 0.5g/kg 13. Health functional food(only coating of tablet or capsule) and capsules: no more than 0.3g/kg 	<p>Colour</p>

<p>Food Red No.3</p>	<p>Food Red No.3 should be used only for the following food items. The usage should be</p> <ol style="list-style-type: none"> 1. Confectionery and candies: no more than 0.3g/kg 2. Chewing gum: no more than 0.05g/kg 3. Frozen confectionery products: no more than 0.15g/kg 4. Breads, rice cakes and dumpling: no more than 0.3g/kg 5. Other processed cocoa products and chocolates: no more than 0.3g/kg 6. Other jam, other sugar and other taffies: no more than 0.3g/kg 7. Sausages: no more than 0.03g/kg 8. Fish sausage: no more than 0.3g/kg 9. Fruit/vegetable beverages, carbonated beverages and other beverages: no more than 0.3g/kg(However, the product that is to be diluted before drinking is based on the diluted form) 10. Spices products(only processed horseradish products and processed mustard products): no more than 0.5g/kg 11. Sauce: no more than 0.3g/kg 12. Salted-fermented seafood products(only <i>myeongnan-jeot</i>): no more than 0.5g/kg 13. Pickled food products(only Hermetic sealing, heat-pasteurization or sterilization pickled food products, but excluding pickled radish): no more than 0.2g/kg 14. Alcoholic beverages(excluding <i>Takju</i>, <i>Yakju</i>, <i>Soju</i>, and <i>Cheongju</i> which is not added to spirits): no more than 0.3g/kg 15. Ready-to-eat foods : no more than 0.3g/kg 16. Processed cereal product and processed starch product: no more than 0.3g/kg 17. Processed tuberous and corn vegetable product: no more than 0.2g/kg 	<p>Colour</p>
-----------------------------	---	---------------

18. Other processed edible fat and oil product, other processed fishery product, and other processed product: no more than 0.5g/kg
19. Processed saccharide product: no more than 0.1g/kg
20. Health functional food(only coating of tablet or capsule) and capsules: no more than 0.3g/kg
21. Ice creams and ice cream mixes: no more than 0.3g/kg

<p>Food Red No.40</p>	<p>Food Red No.40 should be used only for the following food items. The usage should be</p> <ol style="list-style-type: none"> 1. Confectionery, candies and chewing gum: no more than 0.3g/kg 2. Frozen confectionery products: no more than 0.15g/kg 3. Breads and rice cakes: no more than 0.3g/kg 4. Other processed cocoa products and chocolates: no more than 0.3g/kg 5. Other jam: no more than 0.3g/kg 6. Other sugar, other taffies, and sugar syrups: no more than 0.3g/kg 7. Sausages: no more than 0.025g/kg 8. Fish sausage: no more than 0.3g/kg 9. Fruit/vegetable beverages, carbonated beverages and other beverages: no more than 0.3g/kg(However, the product that is to be diluted before drinking is based on the diluted form) 10. Spices products(only processed horseradish products and processed mustard products): no more than 0.3g/kg 11. Sauce: no more than 0.3g/kg 12. Salted-fermented seafood products(only <i>myeongnan-jeot</i>): no more than 0.3g/kg 13. Pickled food products(only Hermetic sealing, heat-pasteurization or sterilization pickled food products, but excluding pickled radish): no more than 0.3g/kg 14. Alcoholic beverages(excluding <i>Takju</i>, <i>Yakju</i>, <i>Soju</i>, and <i>Cheongju</i> which is not added to spirits): no more than 0.3g/kg 15. Vegetable cream and ready-to-eat foods: no more than 0.3g/kg 16. Processed cereal product, processed starch product, processed saccharide product, other processed fishery product, and other processed product: no more than 0.3g/kg 	<p>Colour</p>
------------------------------	--	---------------

17. Processed pulse product and processed tuberous and corn vegetable product: no more than 0.2g/kg
18. Health functional food(only coating of tablet or capsule) and capsules: no more than 0.3g/kg
19. Ice creams and ice cream mixes: no more than 0.3g/kg

<p>Food Red No.40 Aluminium Lake</p>	<p>Food Red No.40 Aluminium Lake should be used only for the following food items. The usage as a Food Red No.40 should be</p> <ol style="list-style-type: none"> 1. Confectionery, candies and chewing gum: no more than 0.3g/kg 2. Frozen confectionery products: no more than 0.15g/kg 3. Breads and rice cakes: no more than 0.3g/kg 4. Other processed cocoa products and chocolates: no more than 0.3g/kg 5. Other jam: no more than 0.3g/kg 6. Other sugar, other taffies, and sugar syrups: no more than 0.3g/kg 7. Sausages: no more than 0.025g/kg 8. Fish sausage: no more than 0.3g/kg 9. Fruit/vegetable beverages, carbonated beverages and other beverages: no more than 0.3g/kg(However, the product that is to be diluted before drinking is based on the diluted form) 10. Spices products(only processed horseradish products and processed mustard products): no more than 0.3g/kg 11. Sauce: no more than 0.3g/kg 12. Salted-fermented seafood products(only <i>myeongnan-jeot</i>): no more than 0.3g/kg 13. Pickled food products(only Hermetic sealing, heat-pasteurization or sterilization pickled food products, but excluding pickled radish): no more than 0.3g/kg 14. Alcoholic beverages(excluding <i>Takju</i>, <i>Yakju</i>, <i>Soju</i>, and <i>Cheongju</i> which is not added to spirits): no more than 0.3g/kg 15. Vegetable cream and ready-to-eat foods: no more than 0.3g/kg 16. Processed cereal product, processed starch product, processed saccharide product, other processed fishery product, and other processed 	<p>Colour</p>
---	---	---------------

product: no more than 0.3g/kg

17. Processed pulse product and processed tuberos and corn vegetable product: no more than 0.2g/kg

18. Health functional food(only coating of tablet or capsule) and capsules: no more than 0.3g/kg

19. Ice creams and ice cream mixes: no more than 0.3g/kg

Food additive	Use Level	Major functional class
Food Starch Modified	It should be used in accordance with Section II.2.1).	Thickener Stabilizer

<p>Food Yellow No.4</p>	<p>Food Yellow No.4 should be used only for the following food items. The usage should be</p> <ol style="list-style-type: none"> 1. Confectionery: no more than 0.2g/kg 2. Candies and chewing gum: no more than 0.3g/kg 3. Frozen confectionery products: no more than 0.15g/kg 4. Breads: no more than 0.2g/kg 5. Rice cakes: no more than 0.15g/kg 6. Dumpling: no more than 0.5g/kg 7. Other processed cocoa product and chocolates: no more than 0.4g/kg 8. Other jam: no more than 0.2g/kg 9. Other sugar, other taffies, and sugar syrups: no more than 0.5g/kg 10. Sausages: no more than 0.3g/kg 11. Fish sausage: no more than 0.5g/kg 12. Fruit/vegetable beverages, carbonated beverages and other beverages: no more than 0.1g/kg(However, the product that is to be diluted before drinking is based on the diluted form) 13. Spices products(only processed horseradish products and processed mustard products): no more than 0.5g/kg 14. Sauce: no more than 0.5g/kg 15. Salted-fermented seafood products(only <i>myeongnan-jeot</i>): no more than 0.5g/kg 16. Pickled food products(only Hermetic sealing, heat-pasteurization or sterilization pickled food products, but excluding pickled radish): no more than 0.5g/kg 17. Alcoholic beverages(excluding <i>Takju</i>, <i>Yakju</i>, <i>Soju</i>, and <i>Cheongju</i> which is not added to spirits): no more than 0.2g/kg 18. Vegetable cream: no more than 0.5g/kg 19. Ready-to-eat foods: no more than 0.05g/kg 20. Processed pulse product and processed 	<p>Colour</p>
--------------------------------	--	---------------

tuberous and corn vegetable product: no more than 0.1g/kg

21. Processed cereal product, processed starch product, processed saccharide product, other processed fishery product, and other processed product: no more than 0.5g/kg
22. Other processed edible fat and oil product: no more than 0.3g/kg
23. Health functional food(only coating of tablet or capsule) and capsules: no more than 0.3g/kg
24. Ice creams, ice cream mixes: no more than 0.15g/kg

<p>Food Yellow No.4 Aluminium Lake</p>	<p>Food Yellow No.4 Aluminium Lake should be used only for the following food items. The usage as a Food Yellow No.4 should be</p> <ol style="list-style-type: none"> 1. Confectionery: no more than 0.2g/kg 2. Candies and chewing gum: no more than 0.3g/kg 3. Frozen confectionery products: no more than 0.15g/kg 4. Breads: no more than 0.2g/kg 5. Rice cakes: no more than 0.15g/kg 6. Dumpling: no more than 0.5g/kg 7. Other processed cocoa product and chocolates: no more than 0.4g/kg 8. Other jam: no more than 0.2g/kg 9. Other sugar, other taffies, and sugar syrups: no more than 0.5g/kg 10. Sausages: no more than 0.3g/kg 11. Fish sausage: no more than 0.5g/kg 12. Fruit/vegetable beverages, carbonated beverages and other beverages: no more than 0.1g/kg(However, the product that is to be diluted before drinking is based on the diluted form) 13. Spices products(only processed horseradish products and processed mustard products): no more than 0.5g/kg 14. Sauce: no more than 0.5g/kg 15. Salted-fermented seafood products(only <i>myeongnan-jeot</i>): no more than 0.5g/kg 16. Pickled food products(only Hermetic sealing, heat-pasteurization or sterilization pickled food products, but excluding pickled radish): no more than 0.5g/kg 17. Alcoholic beverages(excluding <i>Takju</i>, <i>Yakju</i>, <i>Soju</i>, and <i>Cheongju</i> which is not added to spirits): no more than 0.2g/kg 18. Vegetable cream: no more than 0.5g/kg 19. Ready-to-eat foods: no more than 0.05g/kg 	<p>Colour</p>
---	--	---------------

20. Processed pulse product and processed tuberous and corn vegetable product: no more than 0.1g/kg
21. Processed cereal product, processed starch product, processed saccharide product, other processed fishery product, and other processed product: no more than 0.5g/kg
22. Other processed edible fat and oil product: no more than 0.3g/kg
23. Health functional food(only coating of tablet or capsule) and capsules: no more than 0.3g/kg
24. Ice creams, ice cream mixes: no more than 0.15g/kg

<p>Food Yellow No.5</p>	<p>Food Yellow No.5 should be used only for the following food items. The usage should be</p> <ol style="list-style-type: none"> 1. Confectionery: no more than 0.2g/kg 2. Candies and chewing gum: no more than 0.3g/kg 3. Frozen confectionery products, breads and rice cakes: no more than 0.05g/kg 4. Dumpling: no more than 0.4g/kg 5. Other processed cocoa product and chocolates: no more than 0.4g/kg 6. Other jam: no more than 0.3g/kg 7. Other sugar, other taffies, and sugar syrups: no more than 0.4g/kg 8. Sausages and fish sausage: no more than 0.3g/kg 9. Fruit/vegetable beverages, carbonated beverages and other beverages: no more than 0.1g/kg(However, the product that is to be diluted before drinking is based on the diluted form) 10. Spices products(only processed horseradish products and processed mustard products): no more than 0.3g/kg 11. Sauce: no more than 0.3g/kg 12. Salted-fermented seafood products(only <i>myeongnan-jeot</i>): no more than 0.3g/kg 13. Pickled food products(only Hermetic sealing, heat-pasteurization or sterilization pickled food products, but excluding pickled radish): no more than 0.3g/kg 14. Alcoholic beverages(excluding <i>Takju</i>, <i>Yakju</i>, <i>Soju</i>, and <i>Cheongju</i> which is not added to spirits): no more than 0.2g/kg 15. Processed starch product and Vegetable cream: no more than 0.4g/kg 16. Ready-to-eat foods: no more than 0.3g/kg 17. Processed cereal product, other processed edible fat and oil product and processed 	<p>Colour</p>
--------------------------------	--	---------------

saccharide product: no more than 0.3g/kg

18. Processed tuberous and corn vegetable product: no more than 0.05g/kg

19. Other processed fishery product: no more than 0.2g/kg

20. Other processed product: no more than 0.4g/kg

21. Health functional food(only coating of tablet or capsule) and capsules: no more than 0.3g/kg

22. Ice creams, ice cream mixes: no more than 0.3g/kg

<p>Food Yellow No.5 Aluminium Lake</p>	<p>Food Yellow No.5 Aluminium Lake should be used only for the following food items. The usage as a Food Yellow No.5 should be</p> <ol style="list-style-type: none"> 1. Confectionery: no more than 0.2g/kg 2. Candies and chewing gum: no more than 0.3g/kg 3. Frozen confectionery products, breads and rice cakes: no more than 0.05g/kg 4. Dumpling: no more than 0.4g/kg 5. Other processed cocoa product and chocolates: no more than 0.4g/kg 6. Other jam: no more than 0.3g/kg 7. Other sugar, other taffies, and sugar syrups: no more than 0.4g/kg 8. Sausages and fish sausage: no more than 0.3g/kg 9. Fruit/vegetable beverages, carbonated beverages and other beverages: no more than 0.1g/kg(However, the product that is to be diluted before drinking is based on the diluted form) 10. Spices products(only processed horseradish products and processed mustard products): no more than 0.3g/kg 11. Sauce: no more than 0.3g/kg 12. Salted-fermented seafood products(only <i>myeongnan-jeot</i>): no more than 0.3g/kg 13. Pickled food products(only Hermetic sealing, heat-pasteurization or sterilization pickled food products, but excluding pickled radish): no more than 0.3g/kg 14. Alcoholic beverages(excluding <i>Takju</i>, <i>Yakju</i>, <i>Soju</i>, and <i>Cheongju</i> which is not added to spirits): no more than 0.2g/kg 15. Processed starch product and Vegetable cream: no more than 0.4g/kg 16. Ready-to-eat foods: no more than 0.3g/kg 17. Processed cereal product, other processed 	<p>Colour</p>
---	--	---------------

edible fat and oil product and processed saccharide product: no more than 0.3g/kg

18. Processed tuberous and corn vegetable product: no more than 0.05g/kg

19. Other processed fishery product: no more than 0.2g/kg

20. Other processed product: no more than 0.4g/kg

21. Health functional food(only coating of tablet or capsule) and capsules: no more than 0.3g/kg

22. Ice creams, ice cream mixes: no more than 0.3g/kg

Food additive	Use Level	Major functional class
Formic Acid	Formic acid should be used for flavorings only.	Flavouring agent
Fumaric acid	It should be used in accordance with Section II.2.1).	Acidity regulator
Furcelleran	It should be used in accordance with Section II.2.1).	Stabilizer Thickener
α-galactosidase	It should be used in accordance with Section II.2.1).	Enzyme preparations
Gallic Acid	It should be used in accordance with Section II.2.1).	Antioxidant
Garden Balsam Extract	It should be used in accordance with Section II.2.1).	Antioxidant
Gardenia Blue	<p>Gardenia blue should not be used in the food items listed below.</p> <ol style="list-style-type: none"> 1. Natural food[meat, fishes and shellfishes, fruits, vegetables, algae, Legume vegetables and pulses, and their simply processed food(peeled, cut, and etc.)] 2. Teas 3. Coffee 4. Hot pepper powder, shredded hot pepper 5. <i>Kimchi</i> products 6. <i>Gochujang</i>(hot pepper soy paste), seasoned hot pepper soy paste 7. Vinegars 	Colour

Food additive	Use Level	Major functional class
Gardenia Red	<p>Gardenia red should not be used in the food items listed below.</p> <ol style="list-style-type: none"> 1. Natural food[meat, fishes and shellfishes, fruits, vegetables, algae, Legume vegetables and pulses, and their simply processed food(peeled, cut, and etc.)] 2. Teas 3. Coffee 4. Hot pepper powder, shredded hot pepper 5. <i>Kimchi</i> products 6. <i>Gochujang</i>(hot pepper soy paste), seasoned hot pepper soy paste 7. Vinegars 	Colour
Gardenia Yellow	<p>Gardenia yellow should not be used in the food items listed below.</p> <ol style="list-style-type: none"> 1. Natural food[meat, fishes and shellfishes, fruits, vegetables, algae, Legume vegetables and pulses, and their simply processed food(peeled, cut, and etc.)] 2. Teas 3. Coffee 4. Hot pepper powder, shredded hot pepper 5. <i>Kimchi</i> products 6. <i>Gochujang</i>(hot pepper soy paste), seasoned hot pepper soy paste 7. Vinegars 	Colour
Gelatin	It should be used in accordance with Section II.2.1).	Emulsifier Gelling agent Stabilizer
Gellan Gum	It should be used in accordance with Section II.2.1).	Thickener Stabilizer

Food additive	Use Level	Major functional class
Geraniol	Geraniol should be used for flavorings only.	Flavouring agent
Geranyl Acetate	Geranyl Acetate should be used for flavorings only.	Flavouring agent
Geranyl Formate	Geranyl Formate should be used for flavorings only.	Flavouring agent
Gibberellic Acid	Gibberellic acid should be used only for the following for the following food item. 1. For manufacturing malt of fermented alcoholic beverage and distilled alcoholic beverage	manufacturing solvent
Glacial Acetic Acid	It should be used in accordance with Section II.2.1).	Acidity regulator
β-Glucanase	It should be used in accordance with Section II.2.1).	Enzyme preparations
Glucoamylase	It should be used in accordance with Section II.2.1).	Enzyme preparations
Glucomannan	It should be used in accordance with Section II.2.1).	Thickener Stabilizer
Gluconic Acid	It should be used in accordance with Section II.2.1).	Acidity regulator
Glucono-δ-Lactone	It should be used in accordance with Section II.2.1).	Tofu Firming agent Acidity regulator Raising agent
Glucosamine	It should be used in accordance with Section II.2.1).	Thickener Stabilizer
α-Glucosidase	It should be used in accordance with Section II.2.1).	Enzyme preparations

Food additive	Use Level	Major functional class
Glucose Isomerase	It should be used in accordance with Section II.2.1).	Enzyme preparations
Glucose Oxidase	It should be used in accordance with Section II.2.1).	Enzyme preparations
L-Glutamic Acid	It should be used in accordance with Section II.2.1).	Flavour enhancer Fortifying nutrient
Glutaminase	It should be used in accordance with Section II.2.1).	Enzyme preparations
L-Glutamine	It should be used in accordance with Section II.2.1).	Fortifying nutrient
Glycerin	It should be used in accordance with Section II.2.1).	Humectant Stabilizer
Glycerin Esters of Fatty Acids	It should be used in accordance with Section II.2.1).	Emulsifier Gum base
Glycine	It should be used in accordance with Section II.2.1).	Fortifying nutrient Flavour enhancer
β-Glycosidase	It should be used in accordance with Section II.2.1).	Enzyme preparations
Gold Leaf	Gold Leaf should be used only for the following food items 1. Alcoholic beverages and jams 2. Other foods(Exterior coatings or exterior decorations only)	Colour

Food additive	Use Level	Major functional class
Grape Juice Color	<p>Grape juice color should not be used in the food items listed below.</p> <ol style="list-style-type: none"> 1. Natural food[meat, fishes and shellfishes, fruits, vegetables, algae, Legume vegetables and pulses, and their simply processed food(peeled, cut, and etc.)] 2. Teas 3. Coffee 4. Hot pepper powder, shredded hot pepper 5. <i>Kimchi</i> products 6. <i>Gochujang</i>(hot pepper soy paste), seasoned hot pepper soy paste 7. Vinegars 8. Spice Products(only the products containing hot pepper or hot pepper powder) 	Colour
Grape Seed Extract	It should be used in accordance with Section II.2.1).	Antioxidant
Grape Skin Extract	<p>Grape Skin Extract should not be used in the food items listed below.</p> <ol style="list-style-type: none"> 1. Natural food[meat, fishes and shellfishes, fruits, vegetables, algae, Legume vegetables and pulses, and their simply processed food(peeled, cut, and etc.)] 2. Teas 3. Coffee 4. Hot pepper powder, shredded hot pepper 5. <i>Kimchi</i> products 6. <i>Gochujang</i>(hot pepper soy paste), seasoned hot pepper soy paste 7. Vinegars 	Colour
Grapefruit Seed Extract	It should be used in accordance with Section II.2.1).	Preservative

Food additive	Use Level	Major functional class
		ng solvent
Guar Gum	It should be used in accordance with Section II.2.1).	Thickener Stabilizer
Gum Ghatti	It should be used in accordance with Section II.2.1).	Thickener Stabilizer
Heme Iron	It should be used in accordance with Section II.2.1).	Fortifying nutrient
Hemicellulase	It should be used in accordance with Section II.2.1).	Enzyme preparations
Hesperidin	It should be used in accordance with Section II.2.1).	Fortifying nutrient
Hexane	Hexane should be used only for the following food items or function. The sum of the residues as hexane should be <ol style="list-style-type: none"> 1. For extracting fats and oil component when manufacturing edible fats and oils: no more than 0.005g/kg 2. For extracting or separating functional material of health functional food: no more than 0.005g/kg 	Extraction solvent

Food additive	Use Level	Major functional class
Hibiscus Color	<p>Hibiscus Color should not be used in the food items listed below.</p> <ol style="list-style-type: none"> 1. Natural food[meat, fishes and shellfishes, fruits, vegetables, algae, Legume vegetables and pulses, and their simply processed food(peeled, cut, and etc.)] 2. Teas 3. Coffee 4. Hot pepper powder, shredded hot pepper 5. <i>Kimchi</i> products 6. <i>Gochujang</i>(hot pepper soy paste), seasoned hot pepper soy paste 7. Vinegars 	Colour
L-Histidine	It should be used in accordance with Section II.2.1).	Fortifying nutrient
L-Histidine Monohydrochloride	It should be used in accordance with Section II.2.1).	Fortifying nutrient
Hyaluronic acid	It should be used in accordance with Section II.2.1).	Thickener Stabilizer
Hydrochloric Acid	Hydrochloric Acid should be neutralized or removed before the final product is completed.	manufacturing solvent
Hydrogen	<p>Hydrogen should be used only for the following food items or function.</p> <ol style="list-style-type: none"> 1. For hydrogenating in the manufacture of edible fats and oils(excluding animal fats and oils, imitation cheese and vegetable cream) 2. Beverages(excluding teas and coffee) 	Packaging gas manufacturing solvent
Hydrogen Peroxide	Hydrogen peroxide should be decomposed or removed before the final product is completed.	Sterilizing agent manufacturing solvent
Hydroxycitronellal	Hydroxycitronellal should be used for flavorings	Flavouring

Food additive	Use Level	Major functional class
	only.	agent
Hydroxycitronellal Dimethylacetal	Hydroxycitronellal Dimethylacetal should be used for flavorings only.	Flavouring agent
Hydroxypropyl Cellulose	It should be used in accordance with Section II.2.1).	Thickener Stabilizer
Hydroxypropylmethyl Cellulose	It should be used in accordance with Section II.2.1).	Thickener Stabilizer
Hypochlorous Acid Water	Hypochlorous Acid Water should be used for sterilization of foods such as fruits, vegetables, and etc and it should be removed before the final product is completed.	Sterilizing agent
Inositol	It should be used in accordance with Section II.2.1).	Fortifying nutrient
Invertase	It should be used in accordance with Section II.2.1).	Enzyme preparations
Ion Exchange Resin	Ion Exchange Resins(granule, dispersion and suspension) should be removed before the final product is completed.	manufacturing solvent
α-Ionone	α-Ionone should be used for flavorings only.	Flavouring agent
β-Ionone	β-Ionone should be used for flavorings only.	Flavouring agent
Iron Sesquioxide	Iron Sesquioxide should be used only for following food items. 1. Bananas(only severed surface of the banana tip) 2. <i>Konjac</i>	Colour
Iron, Electrolytic	It should be used in accordance with Section II.2.1).	Fortifying nutrient
Iron, Reduced	It should be used in accordance with Section	Fortifying

Food additive	Use Level	Major functional class
	II.2.1).	nutrient
Isoamyl Acetate	Isoamyl Acetate should be used for flavorings only.	Flavouring agent
Isoamyl Butyrate	Isoamyl Butyrate should be used for flavorings only.	Flavouring agent
Isoamyl Formate	Isoamyl Formate should be used for flavorings only.	Flavouring agent
Isoamyl isovalerate	Isoamyl Isovalerate should be used for flavorings only.	Flavouring agent
Isoamyl Propionate	Isoamyl Propionate should be used for flavorings only.	Flavouring agent
Isobutyl Phenylacetate	Isobutyl Phenylacetate should be used for flavorings only.	Flavouring agent
Isoeugenol	Isoeugenol should be used for flavorings only.	Flavouring agent
L-Isoleucine	It should be used in accordance with Section II.2.1).	Fortifying nutrient
Isomalt	It should be used in accordance with Section II.2.1).	Sweetener
Isopropyl Alcohol	<p>Isopropyl Alcohol should be used only for the following food items or function.</p> <ol style="list-style-type: none"> 1. For flavorings 2. Sugars : not more than 0.01g/kg(The sum of residues as isopropyl alcohol) 3. For extracting or separating functional material of health functional food: not more than 0.05g/kg(The sum of residues as isopropyl alcohol) 	<p>manufacturing solvent Extraction solvent</p>

Food additive	Use Level	Major functional class
Itaconic Acid	It should be used in accordance with Section II.2.1).	Acidity regulator
Kaoliang Color	<p>Kaoliang Color should not be used in the food items listed below.</p> <ol style="list-style-type: none"> 1. Natural food[meat, fishes and shellfishes, fruits, vegetables, algae, Legume vegetables and pulses, and their simply processed food(peeled, cut, and etc.)] 2. Teas 3. Coffee 4. Hot pepper powder, shredded hot pepper 5. <i>Kimchi</i> products 6. <i>Gochujang</i>(hot pepper soy paste), seasoned hot pepper soy paste 7. Vinegars 	Colour
Kaolin	Kaolin should be used only for a filtering aid(filtering, discoloring, deodorizing, refining, and etc.) in food manufacturing or processing. However, it should be removed before the final product is completed. The residual amount should be no more than 0.5%(if it is used with diatomaceous earth, acid clay, bentonite, talc, perlite, activated carbon, and other insoluble minerals, the sum of the residues should be no more than 0.5%).	Filter aid
Karaya Gum	It should be used in accordance with Section II.2.1).	Thickener Stabilizer
Koji	It should be used in accordance with Section II.2.1).	Enzyme preparations

Food additive	Use Level	Major functional class
Lac Color	<p>Lac Color should not be used in the food items listed below.</p> <ol style="list-style-type: none"> 1. Natural food[meat, fishes and shellfishes, fruits, vegetables, algae, Legume vegetables and pulses, and their simply processed food(peeled, cut, and etc.)] 2. Teas 3. Coffee 4. Hot pepper powder, shredded hot pepper 5. <i>Kimchi</i> products 6. <i>Gochujang</i>(hot pepper soy paste), seasoned hot pepper soy paste 7. Vinegars 8. Spice Products(only the products containing hot pepper or hot pepper powder) 	Colour
Lactase	It should be used in accordance with Section II.2.1).	Enzyme preparations
Lactic Acid	It should be used in accordance with Section II.2.1).	Acidity regulator
Lactitol	It should be used in accordance with Section II.2.1).	Sweetener Humectant
Lactoferrin Concentrates	It should be used in accordance with Section II.2.1).	Fortifying nutrient
Lauric Acid	It should be used in accordance with Section II.2.1).	Antifoaming agent manufacturing solvent

Food additive	Use Level	Major functional class
Laver Color	Laver Color should not be used in the food items listed below. <ol style="list-style-type: none"> 1. Natural food[meat, fishes and shellfishes, fruits, vegetables, algae, Legume vegetables and pulses, and their simply processed food(peeled, cut, and etc.)] 2. Teas 3. Coffee 4. Hot pepper powder, Shredded hot pepper 5. <i>Kimchi</i> products 6. <i>Gochujang</i>(hot pepper soy paste), Seasoned hot pepper soy paste 7. Vinegars 	Colour
Lecithin	It should be used in accordance with Section II.2.1).	Emulsifier
L-Leucine	It should be used in accordance with Section II.2.1).	Fortifying nutrient
Licorice Extract	It should be used in accordance with Section II.2.1).	Sweetener
Linalool	Linalool should be used for flavorings only.	Flavouring agent
Linalyl Acetate	Linalyl Acetate should be used for flavorings only.	Flavouring agent
Lipase	It should be used in accordance with Section II.2.1).	Enzyme preparations
Liquid Paraffin	Liquid Paraffin should be used only for the following food items. The usage should be <ol style="list-style-type: none"> 1. Breads : no more than 0.15%(for a releasing agent) 2. Capsules : no more than 0.6%(for a releasing agent) 3. Dried fruits and vegetables : no more than 	Releasing agent Coating agent

Food additive	Use Level	Major functional class
	0.02%(for a releasing agent) 4. Fruits and vegetables(for a coating agent)	
Locust Bean Gum	It should be used in accordance with Section II.2.1).	Thickener Stabilizer
L-Lysine	It should be used in accordance with Section II.2.1).	Fortifying nutrient
L-Lysine Monohydrochloride	It should be used in accordance with Section II.2.1).	Fortifying nutrient
Lysozyme	It should be used in accordance with Section II.2.1).	Enzyme preparations
Magnesium Carbonate	It should be used in accordance with Section II.2.1).	Acidity regulator Raising agent Fortifying nutrient
Magnesium Chloride	It should be used in accordance with Section II.2.1).	Soybean curds Firming agent Fortifying nutrient
Magnesium Gluconate	It should be used in accordance with Section II.2.1).	Acidity regulator Fortifying nutrient
Magnesium Hydroxide	It should be used in accordance with Section II.2.1).	Acidity regulator Fortifying

Food additive	Use Level	Major functional class
		nutrient
Magnesium L-Lactate	It should be used in accordance with Section II.2.1).	Acidity regulator Fortifying nutrient
Magnesium Oxide	It should be used in accordance with Section II.2.1).	Fortifying nutrient
Magnesium Phosphate, Dibasic	It should be used in accordance with Section II.2.1).	Acidity regulator Fortifying nutrient Raising agent
Magnesium Phosphate, Tribasic	It should be used in accordance with Section II.2.1).	Acidity regulator Fortifying nutrient Raising agent

Food additive	Use Level	Major functional class
Magnesium Silicate	<p>Magnesium Silicate should be used only for anticaking agent and filtering aid. If it is used for filtering aid, it should be removed before the final product is completed, and if it is used for anticaking agent, it should be used only for the following food items and the usage should be</p> <ol style="list-style-type: none"> 1. Processed milk cream(powder products for vending machine only) : no more than 1%(if it is used with silicon dioxide or calcium silicate, the sum of usage should be no more than 1%) 2. Powdered milks(products for vending machine only) : no more than 1% (if it is used with silicon dioxide or calcium silicate, the sum of usage should be no more than 1%) 3. Edible salts : no more than 2%(if it is used with silicon dioxide or calcium silicate, the sum of usage should be no more than 2%) 	<p>Anticaking agent Filter aid</p>
Magnesium Stearate	It should be used in accordance with Section II.2.1).	<p>Fortifying nutrient Emulsifier</p>
Magnesium Sulfate	It should be used in accordance with Section II.2.1).	<p>Soybean curds Firming agent Fortifying nutrient</p>

Food additive	Use Level	Major functional class
Maize Morado Color	<p>Maize Morado Color should not be used in the food items listed below.</p> <ol style="list-style-type: none"> 1. Natural food[meat, fishes and shellfishes, fruits, vegetables, algae, Legume vegetables and pulses, and their simply processed food(peeled, cut, and etc.)] 2. Teas 3. Coffee 4. Hot pepper powder, shredded hot pepper 5. <i>Kimchi</i> products 6. <i>Gochujang</i>(hot pepper soy paste), seasoned hot pepper soy paste 7. Vinegars 8. Spice products(only the products containing hot pepper or hot pepper powder) 	Colour
DL-Malic Acid	It should be used in accordance with Section II.2.1).	Acidity regulator Raising agent
D-Maltitol	It should be used in accordance with Section II.2.1).	Sweetener Humectant
Maltitol Syrup	It should be used in accordance with Section II.2.1).	Sweetener Humectant
Maltogenic Amylase	It should be used in accordance with Section II.2.1).	Enzyme preparations
Maltol	Maltol should be used for flavorings only.	Flavouring agent
Maltotriohydrolase	It should be used in accordance with Section II.2.1).	Enzyme preparations
Manganese Chloride	It should be used in accordance with Section II.2.1).	Fortifying nutrient

Food additive	Use Level	Major functional class
Manganese citrate	It should be used in accordance with Section II.2.1).	Fortifying nutrient
Manganese Gluconate	<p>Manganese Gluconate should be used only for the following food items.</p> <ol style="list-style-type: none"> 1. Breads 2. Carbonated beverages, other beverages(which are mixed beverage and beverage base) 3. Milk products(excluding ice creams and ice cream mixes) 4. Processed meat products(excluding Meat extract product) 5. Processed egg products 6. Processed fish meat products 7. Imitation cheese 8. Vegetable cream 9. Milk formulas, Infant formulas, follow-up formulas, Cereal formulas for infants/young children, Other foods for infants/young children, Formulas for infants/young children with milk protein allergy, Special formulas for infants/young children 10. Health functional food 	Fortifying nutrient
Manganese Sulfate	It should be used in accordance with Section II.2.1).	Fortifying nutrient
D-Mannitol	It should be used in accordance with Section II.2.1).	Sweetener Humectant
Masticatory Substances	Masticatory Substances should be used for chewing gum base only.	Gum base
dl-Menthol	<i>d</i> l-Menthol should be used for flavorings only.	Flavouring agent
l-Menthol	<i>l</i> -Menthol should only be used for flavorings only.	Flavouring agent

Food additive	Use Level	Major functional class
DL-Methionine	It should be used in accordance with Section II.2.1).	Fortifying nutrient
L-Methionine	It should be used in accordance with Section II.2.1).	Fortifying nutrient
p-Methyl Acetophenone	p-Methyl Acetophenone should be used for flavorings only.	Flavouring agent
Methyl Alcohol	Methyl Alcohol should be used only for extraction and separation of functional raw material in health functional foods. The sum of residues should be no more than 0.05 g/kg.	Extraction solvent
Methyl Anthranilate	Methyl Anthranilate should be used for flavorings only.	Flavouring agent
Methyl Cellulose	Methyl Cellulose should be used no more than 2% in the food(if it is used with Sodium Carboxymethylcellulose, Calcium Carboxymethylcellulose or Sodium Carboxymethyl Starch, the sum of usage should be no more than 2% in the food). However, health functional foods are not restricted.	Thickener Stabilizer
Methyl Cinnamate	Methyl Cinnamate should be used for flavorings only.	Flavouring agent
Methyl Hesperidin	It should be used in accordance with Section II.2.1).	Fortifying nutrient

<p>Methyl p - Hydroxybenzoate</p>	<p>Methyl p-Hydroxybenzoate should be used only for the following food items. The usage of Methyl p-Hydroxybenzoate as p-hydroxybenzoic acid should be</p> <ol style="list-style-type: none"> 1. Capsules : no more than 1.0g/kg 2. Jams: no more than 1.0g/kg(if it is used with sorbic acid, potassium sorbate, calcium sorbate, benzoic acid, potassium benzoate, calcium benzoate, sodium benzoate, ethyl p-hydroxybenzoate, propionic acid, sodium propionate, and calcium propionate, the sum of usage as sorbic acid, benzoic acid, p-hydroxybenzoic acid, and propionic acid should be no more than 1.0g/kg) 3. Mango chutney: no more than 0.25g/kg(if it is used with sodium benzoate , potassium benzoate, calcium benzoate and ethyl p-hydroxybenzoate, the sum of usage as benzoic acid and p-hydroxybenzoic acid should be no more than 0.25g/kg) 4. Korean-style soy sauce, Brewed soy sauce, Acid-hydrolyzed soy sauce, Enzyme-hydrolyzed soy sauce, Blended soy sauce : no more than 0.25g/kg(if it is used with benzoic acid, sodium benzoate, potassium benzoate, calcium benzoate, the sum of usage as benzoic acid and p-hydroxybenzoic acid should be no more than 0.6g/kg, and the usage as p-hydroxybenzoic acid should be no more than 0.25g/kg) 5. Vinegars : no more than 0.1g/L. 6. Other beverages(excluding powder products), Ginseng/red ginseng beverages: no more than 0.1g/kg(if it is used with benzoic acid, sodium benzoate, potassium benzoate, calcium benzoate, the sum of usage as benzoic acid and p-hydroxybenzoic acid should be no more than 0.6g/kg, and the usage as p- 	<p>Preservative</p>
--	--	---------------------

hydroxybenzoic acid should be no more than 0.1g/kg)

7. Sauce : no more than 0.2g/kg(if it is used with sorbic acid, potassium sorbate or calcium sorbate, the sum of usage as p-hydroxybenzoic acid and sorbic acid should be no more than 1.0g/kg, and the usage as p-hydroxybenzoic acid should be no more than 0.2g/kg)

8. Fruits(peels only) : no more than 0.012g/kg

9. Vegetables(peels only) : no more than 0.012g/kg

Food additive	Use Level	Major functional class
Methyl N-Methylantranilate	Methyl <i>N</i> -Methylantranilate should be used for flavorings only.	Flavouring agent
Methyl β-Naphthyl Ketone	Methyl β -Naphthyl Ketone should be used for flavorings only.	Flavouring agent
Methyl Salicylate	Methyl Salicylate should be used for flavorings only.	Flavouring agent
Methyl ethyl cellulose	It should be used in accordance with Section II.2.1).	Thickener Stabilizer
(6S)-5-Methyltetrahydrofolic Acid, Glucosamine Salt	(6S)-5-Methyltetrahydrofolic Acid, Glucosamine Salt should be used only for the following food item. 1. Health functional food	fortifying nutrient
Microfibrillated Cellulose	It should be used in accordance with Section II.2.1).	Thickener Stabilizer
Milk Clotting Enzyme	It should be used in accordance with Section II.2.1).	Enzyme preparations
Milt Protein	It should be used in accordance with Section II.2.1).	Fortifying nutrient
Modified Hop Extract	Modified Hop Extract should be used for Beer only.	Flavour enhancer

Food additive	Use Level	Major functional class
Monascus Color	<p>Monascus color should not be used in the food items listed below.</p> <ol style="list-style-type: none"> 1. Natural food[meat, fishes and shellfishes, fruits, vegetables, algae, Legume vegetables and pulses, and their simply processed food(peeled, cut, and etc.)] 2. Teas 3. Coffee 4. Hot pepper powder, shredded hot pepper 5. <i>Kimchi</i> products 6. <i>Gochujang</i>(hot pepper soy paste), seasoned hot pepper soy paste 7. Vinegars 8. Spice products(only the products containing hot pepper or hot pepper powder) 	Colour
Monascus Yellow	<p>Monascus yellow should not be used in the food items listed below.</p> <ol style="list-style-type: none"> 1. Natural food[meat, fishes and shellfishes, fruits, vegetables, algae, Legume vegetables and pulses, and their simply processed food(peeled, cut, and etc.)] 2. Teas 3. Coffee 4. Hot pepper powder, shredded hot pepper 5. <i>Kimchi</i> products 6. <i>Gochujang</i>(hot pepper soy paste), seasoned hot pepper soy paste 7. Vinegars 	Colour
Monoammonium L-Glutamate	It should be used in accordance with Section II.2.1).	Flavour enhancer
Monopotassium L-Glutamate	It should be used in accordance with Section II.2.1).	Flavour enhancer

Food additive	Use Level	Major functional class
Monosodium Fumarate	It should be used in accordance with Section II.2.1).	Acidity regulator
Monosodium L-Glutamate	It should be used in accordance with Section II.2.1).	Flavour enhancer
Morpholine Salts of Fatty Acids	Morpholine Salts of Fatty Acids should be used for coating agent on fruit peels or vegetable peels only.	Coating agent
Mucin	It should be used in accordance with Section II.2.1).	Fortifying nutrient
Myristic acid	It should be used in accordance with Section II.2.1).	Antifoaming agent manufacturing solvent
Naringin	It should be used in accordance with Section II.2.1).	Flavour enhancer
Natamycin	Natamycin should be used on the cheese surface only. The usage should be no more than 1mg/dm ² , and should not be detected at the depth of 5 mm and a deeper surface from the surface(no more than 0.020g/kg).	Preservative

Food additive	Use Level	Major functional class
<p>Neotame</p>	<p>Neotame should be used only for the following food items. The usage should be</p> <ol style="list-style-type: none"> 1. Chewing gum: no more than 1.0g/kg 2. Rice cakes: no more than 0.033g/kg 3. Jams: no more than 0.070g/kg 4. Concentrated fruit/vegetable juice: no more than 0.065g/kg 5. Foods for special medical purposes: no more than 0.033g/kg 6. Weight control formulas: no more than 0.065g/kg 7. Vinegars: no more than 0.012g/kg 8. Sauce, Mayonnaise: no more than 0.070g/kg 9. Tomato ketchup: no more than 0.070g/kg 10. Spice preparation: no more than 0.012g/kg 11. Composite seasoning: no more than 0.032g/kg 12. Seasoned fish sauce: no more than 0.012g/kg 13. Picked food: no more than 0.100g/kg 14. Processed peanut or nut products: no more than 0.033g/kg 15. Processed fruit/vegetable product: no more than 0.100g/kg 16. Chesses: no more than 0.033g/kg 17. Vegetable cream: no more than 0.065g/kg 18. Cereals: no more than 0.160g/kg 19. Ready-to-eat food: no more than 0.033g/kg 20. Ready-to-cook food: no more than 0.032g/kg 21. Other processed agricultural product: no more than 0.033g/kg 22. Yeast foods: no more than 0.065g/kg 23. Processed saccharide product: no more than 0.100g/kg 	<p>Sweetener</p>

Food additive	Use Level	Major functional class
	<p>24. Milk creams: no more than 0.065g/kg</p> <p>25. Health functional food: no more than 0.090g/kg</p>	
<p>Nickel</p>	<p>Nickel should be used only for the following food item. and it should be removed before the final product is completed.</p> <p>1. For catalyst in the hydrogenating processing of Blended edible oil, processed fat and oil,</p>	<p>Manufacturing solvent</p>

Food additive	Use Level	Major functional class
	shortening and margarine: not more than 1.0mg/kg(as the sum of the residues)	
Nicotinamide	Nicotinamide should not be used in the food items listed below. 1. Meat 2. Fish and Shellfish(it means fresh shellfish.)	Fortifying nutrient
Nicotinic Acid	Nicotinic Acid should not be used in the food items listed below. 1. Meat 2. Fish and Shellfish(it means fresh shellfish.)	Fortifying nutrient
Nisin	Nisin should be used for processed cheese only. The usage should be no more than 250mg/kg.	Preservative
Nitrogen	It should be used in accordance with Section II.2.1). However, If it is used as a liquid, it should be removed before the final product is completed.	Propellant Packaging gas
Nitrous Oxide	It should be used in accordance with Section II.2.1).	Propellant Packaging gas
γ-Nonalactone	γ -Nonalactone should be used for flavorings only.	Flavouring agent
Octyl Aldehyde	Octyl Aldehyde should be used for flavorings only.	Flavouring agent
Oleic acid	It should be used in accordance with Section II.2.1).	Antifoaming agent manufacturing solvent

Food additive	Use Level	Major functional class
Oleoresin Paprika	<p>Oleoresin Paprika should not be used in the food items listed below.</p> <ol style="list-style-type: none"> 1. Natural food [meat, fishes and shellfishes, fruits, vegetables, algae, Legume vegetables and pulses, and their simply processed food(peeled, cut, and etc.)] 2. Teas 3. Coffee 4. Hot pepper powder, shredded hot pepper 5. <i>Kimchi</i> products 6. <i>Gochujang</i>(hot pepper soy paste), seasoned hot pepper soy paste 7. Vinegars 8. Spice products(only the products containing hot pepper or hot pepper powder) 	Colour
Onion Color	<p>Onion Color should not be used in the food items listed below.</p> <ol style="list-style-type: none"> 1. Natural food [meat, fishes and shellfishes, fruits, vegetables, algae, Legume vegetables and pulses, and their simply processed food(peeled, cut, and etc.)] 2. Teas 3. Coffee 4. Hot pepper powder, shredded hot pepper 5. <i>Kimchi</i> products 6. <i>Gochujang</i>(hot pepper soy paste), seasoned hot pepper soy paste 7. Vinegars 	Colour
γ-Oryzanol	It should be used in accordance with Section II.2.1).	Antioxidant
Oxalic Acid	Oxalic Acid should be removed before the final product is completed.	manufacturing solvent

Food additive	Use Level	Major functional class
Oxygen	It should be used in accordance with Section II.2.1).	Propellant Packaging gas manufacturing solvent
Oxystearin	Oxystearin should be used only for the following food item and the usage should be 1. Edible fats and oils(excluding imitation cheese, vegetable cream) : no more than 0.125%	Stabilizer Antifoaming agent
Ozone Water	Ozone Water should be used for sterilization of foods(fruits, vegetables and etc) only and it should be removed before the final product is completed.	Sterilizing agent
Palmitic Acid	It should be used in accordance with Section II.2.1).	Antifoaming agent manufacturing solvent
Pancreatin	It should be used in accordance with Section II.2.1).	Enzyme preparations
Pecan Nut Color	Pecan nut color should not be used in the food items listed below. 1. Natural food[meat, fishes and shellfishes, fruits, vegetables, algae, Legume vegetables and pulses, and their simply processed food(peeled, cut, and etc.)] 2. Teas 3. Coffee 4. Hot pepper powder, shredded hot pepper 5. <i>Kimchi</i> products 6. <i>Gochujang</i> (hot pepper soy paste), seasoned hot pepper soy paste 7. Vinegars	Colour

Food additive	Use Level	Major functional class
Pectin	It should be used in accordance with Section II.2.1).	Thickener Stabilizer
Pectinase	It should be used in accordance with Section II.2.1).	Enzyme preparations
Pepsin	It should be used in accordance with Section II.2.1).	Enzyme preparations
Perilla Color	<p>Perilla Color should not be used in the food items listed below.</p> <ol style="list-style-type: none"> 1. Natural food[meat, fishes and shellfishes, fruits, vegetables, algae, Legume vegetables and pulses, and their simply processed food(peeled, cut, and etc.)] 2. Teas 3. Coffee 4. Hot pepper powder, shredded hot pepper 5. <i>Kimchi</i> products 6. <i>Gochujang</i>(hot pepper soy paste), seasoned hot pepper soy paste 7. Vinegars 8. Spice products(only the products containing hot pepper or hot pepper powder) 	Colour
Perlite	<p>Perlite should be used for filtering aid(filtering, decolorization, deodorization, refining and etc) during food manufacturing or processing only. However, it should be removed before the final product is completed and the sum of the residues should be no more than 0.5%(if it is used with other insoluble mineral substances such as diatomaceous earth, kaolin, bentonite, acid clay, talc, perlite, active carbon, and etc, the sum of the residues should be no more than 0.5%).</p>	Filter aid

Food additive	Use Level	Major functional class									
<p>Peroxyacetic acid</p>	<p>Peroxyacetic acid should be used only for the following food items. It should be used only for sterilization, and soaking or spread peroxyacetic acid shall be shacked off or drained off from the food surface before the final food product is completed. The usage(concentration) as peroxyacetic acid and 1-hydroxyethylidene-1,1-diphosphonic(HEDP) acid should be no more than</p> <table border="1" data-bbox="639 831 1262 1088"> <thead> <tr> <th data-bbox="639 831 900 887">Ingredient</th> <th data-bbox="900 831 1160 887">Fruits/vegetables</th> <th data-bbox="1160 831 1262 887"></th> </tr> </thead> <tbody> <tr> <td data-bbox="639 887 900 987">Peroxyacetic acid</td> <td data-bbox="900 887 1160 987">0.080g/kg</td> <td data-bbox="1160 887 1262 987">mamma poultry</td> </tr> <tr> <td data-bbox="639 987 900 1088">HEDP</td> <td data-bbox="900 987 1160 1088">0.0048g/kg</td> <td data-bbox="1160 987 1262 1088">mamma poultry</td> </tr> </tbody> </table>	Ingredient	Fruits/vegetables		Peroxyacetic acid	0.080g/kg	mamma poultry	HEDP	0.0048g/kg	mamma poultry	<p>Sterilizing agent</p>
Ingredient	Fruits/vegetables										
Peroxyacetic acid	0.080g/kg	mamma poultry									
HEDP	0.0048g/kg	mamma poultry									
<p>Persimmon Color</p>	<p>Persimmon color should not be used in the food items listed below.</p> <ol style="list-style-type: none"> 1. Natural food[meat, fishes and shellfishes, fruits, vegetables, algae, Legume vegetables and pulses, and their simply processed food(peeled, cut, and etc.)] 2. Teas 3. Coffee 4. Hot pepper powder, shredded hot pepper 5. <i>Kimchi</i> products 6. <i>Gochujang</i>(hot pepper soy paste), seasoned hot pepper soy paste 7. Vinegars 	<p>Colour</p>									
<p>Petroleum Wax</p>	<p>It should be used in accordance with Section II.2.1).</p>	<p>Coating agent Gum base</p>									

Food additive	Use Level	Major functional class
Phaffia Color	<p>Phaffia Color should not be used in the food items listed below.</p> <ol style="list-style-type: none"> 1. Natural food[meat, fishes and shellfishes, fruits, vegetables, algae, Legume vegetables and pulses, and their simply processed food(peeled, cut, and etc.)] 2. Teas 3. Coffee 4. Hot pepper powder, shredded hot pepper 5. <i>Kimchi</i> products 6. <i>Gochujang</i>(hot pepper soy paste), seasoned hot pepper soy paste 7. Vinegars 	Colour
DL-Phenylalanine	It should be used in accordance with Section II.2.1).	Fortifying nutrient
L-Phenylalanine	It should be used in accordance with Section II.2.1).	Fortifying nutrient
Phenylethyl Acetate	Phenylethyl Acetate should be used for flavorings only.	Flavouring agent
Phosphodiesterase	It should be used in accordance with Section II.2.1).	Enzyme preparations
Phospholipase	It should be used in accordance with Section II.2.1).	Enzyme preparations
Phosphoric Acid	It should be used in accordance with Section II.2.1).	Acidity regulator Fortifying nutrient
Phytic Acid	<p>Phytic Acid should not be used for the food items listed below.</p> <ol style="list-style-type: none"> 1. Foods for special dietary uses 2. Health functional food 	Acidity regulator

Food additive	Use Level	Major functional class
Piperonal	Piperonal should be used for flavorings only.	Flavouring agent
Polybutene	Polybutene should be used for a chewing gum base only.	Gum base
Polydextrose	It should be used in accordance with Section II.2.1).	Humectant Stabilizer
Polyethylene Glycol	Polyethylene glycol should be used only for the following food item. The usage should be 1. Health functional food(tablet or its coating, capsule part of capsules only) and capsules for a coating agent: no more than 10 g/kg(the usage applies to total weight of the tablet or capsule)	Coating agent
Polyglycitol Syrup	It should be used in accordance with Section II.2.1).	Sweetener Humectant Stabilizer
Polyisobutylene	Polyisobutylene should be used for a chewing gum base only.	Gum base
Poly-r-glutamic acid	It should be used in accordance with Section II.2.1).	Thickener Stabilizer
ε-Polylysine	It should be used in accordance with Section II.2.1).	Preservative
Polysorbate 20	It should be used in accordance with Section II.2.1).	Emulsifier
Polysorbate 60	It should be used in accordance with Section II.2.1).	Emulsifier
Polysorbate 65	It should be used in accordance with Section II.2.1).	Emulsifier
Polysorbate 80	It should be used in accordance with Section II.2.1).	Emulsifier

Food additive	Use Level	Major functional class
Polyvinyl Acetate	Polyvinyl Acetate should be used only for the following food items. 1. Chewing gum for a gum base 2. Fruit peels or vegetable peels for a coating agent	Gum base Coating agent
Polyvinyl Alcohol	Polyvinyl Alcohol should be used only for health functional food(tablet or its coating, capsule only) and capsules for a coating agent.	Coating agent
Polyvinyl Polypyrrolidone	Polyvinyl Polypyrrolidone should be used only for a filter aid. it should be removed before the final product is completed.	Filter aid
Polyvinyl pyrrolidone	Polyvinyl Pyrrolidone should be used only for food items listed below. the usage should be 1. Beer: no more than 0.01g/kg 2. Vinegars: no more than 0.04g/kg 3. Fruit wine, liqueur: no more than 0.06g/kg 4. Health functional food(tablet or its coating, capsule only) and capsules for a coating agent	Coating agent Stabilizer
Potassium Alginate	It should be used in accordance with Section II.2.1).	Emulsifier Thickener
Potassium Aluminium silicate-based pearlescent pigments	Potassium Aluminium silicate-based pearlescent pigments should be used only for the following food item. 1. Fruit wine, General Distilled Alcoholic Beverage, Liqueur : Not more than 0.3%	Colour

<p>Potassium Benzoate</p>	<p>Potassium Benzoate should be used only for the following food items. The usage as benzoic acid should be</p> <ol style="list-style-type: none"> 1. Fruit/vegetable beverages(excluding non-heated products): no more than 0.6g/kg(However, In case of concentrated fruit juice, and fruit/vegetable juice, if it is used with sorbic acid, potassium sorbate, or calcium sorbate, the sum of usage as benzoic acid and sorbic acid should be no more than 1.0g/kg, and the usage as benzoic acid should be no more than 0.6g/kg) 2. Carbonated beverages: no more than 0.6g/kg(If it is used with sorbic acid, potassium sorbate or calcium sorbate, the sum of usage as benzoic acid and sorbic acid should be no more than 0.6g/kg, and the usage of sorbic acid should be no more than 0.5g/kg) 3. Other beverages(excluding powder products), Ginseng/red ginseng beverages: no more than 0.6g/kg(if it is used with methyl p-hydroxybenzoate or ethyl p-hydroxybenzoate, the sum of usage as benzoic acid and p-hydroxybenzoic acid should be no more than 0.6g/kg, and the usage of p-hydroxybenzoic acid should be no more than 0.1g/kg) 4. Korean-style soy sauce, brewed soy sauce, acid-hydrolyzed soy sauce, enzyme-hydrolyzed soy sauce, blended soy sauce: no more than 0.6g/kg(if it is used with methyl p-hydroxybenzoate or ethyl p-hydroxybenzoate, the sum of usage as benzoic acid and p-hydroxybenzoic acid should be no more than 0.6g/kg, and the usage of p-hydroxybenzoic acid should be no more than 0.25g/kg) 5. Aloe whole leaves(including Aloe gel) health 	<p>Preservative</p>
----------------------------------	---	---------------------

functional food(However, in the case of using more than two kinds of health functional food materials, the usage apply proportion of the aloe whole leaves(including the aloe gel) health functional food content): no more than 0.5g/kg(if it is used with sorbic acid, potassium sorbate, or calcium sorbate, the sum of usage as benzoic acid and sorbic acid should be no more than 1.5g/kg, and the usage of sorbic acid should be no more than 1.0g/kg)

6. Mayonnaise: no more than 1.0g/kg
7. Jams: no more than 1.0g/kg(if it is used with sorbic acid, potassium sorbate, calcium sorbate, methyl p -hydroxybenzoate, ethyl p -hydroxybenzoate, propionic acid, sodium propionate, or calcium propionate, the sum of usage as benzoic acid, sorbic acid, p -hydroxybenzoic acid, and propionic acid should no more than 1.0g/kg)
8. Mango chutney: no more than 0.25g/kg(if it is used with methyl p -hydroxybenzoate or ethyl p -hydroxybenzoate, the sum of usage as benzoic acid and p -hydroxybenzoic acid should be no more than 0.25g/kg).
9. Margarine: no more than 1.0g/kg (if it is used with sorbic acid, potassium sorbate or calcium sorbate, the sum of usage as sorbic acid and benzoic acid should be no more than 2.0g/kg, and the usage as benzoic acid should be no more than 0.1g/kg)
10. Pickled food: no more than 1.0 g/kg(if it is used with sorbic acid, potassium sorbate or calcium sorbate, the sum of usage as benzoic acid and sorbic acid should be no more than 1.5g/kg, and the usage of sorbic acid should be no more than 1.0g/kg)

Food additive	Use Level	Major functional class
Potassium Bicarbonate	It should be used in accordance with Section II.2.1).	Acidity regulator Raising agent Fortifying nutrient
Potassium DL-Bitartrate	It should be used in accordance with Section II.2.1).	Acidity regulator Raising agent
Potassium L-Bitartrate	It should be used in accordance with Section II.2.1).	Acidity regulator Raising agent
Potassium Carbonate, Anhydrous	It should be used in accordance with Section II.2.1).	Acidity regulator Raising agent Fortifying nutrient
Potassium Caseinate	It should be used in accordance with Section II.2.1).	Emulsifier Thickener Stabilizer
Potassium Chloride	It should be used in accordance with Section II.2.1).	Flavour enhancer Gelling agent Fortifying nutrient
Potassium Citrate	It should be used in accordance with Section II.2.1).	Acidity regulator Fortifying

Food additive	Use Level	Major functional class
		nutrient
Potassium Copper Chlorophyllin	<p>Potassium Copper Chlorophyllin should be used only for the following food items. The usage as copper should be</p> <ol style="list-style-type: none"> 1. Kelp(anhydrous form): no more than 0.15g/kg 2. Preserved vegetables or fruits: no more than 0.1g/kg 3. Chewing gum and candies: no more than 0.05g/kg 4. Agar in canned green pea product: no more than 0.0004g/kg 	Colour
Potassium Ferrocyanide	<p>Potassium Ferrocyanide should be used only for edible salts. The usage as ferrocyanide ion should be</p> <ol style="list-style-type: none"> 1. Edible slats: no more than 0.010g/kg(if it is used with calcium ferrocyanide or sodium ferrocyanide, the sum of usage as ferrocyanide ion should be no more than 0.010g/kg) 	Anticaking agent
Potassium Gluconate	It should be used in accordance with Section II.2.1).	Acidity regulator Fortifying nutrient
Potassium Glycerophosphate	It should be used in accordance with Section II.2.1).	Fortifying nutrient
Potassium Hydroxide	Potassium Hydroxide should be removed before the final product is completed.	Acidity regulator

Food additive	Use Level	Major functional class
Potassium Iodate	It should be used in accordance with Section II.2.1).	Fortifying nutrient Flour treatment agent
Potassium Iodide	It should be used in accordance with Section II.2.1).	Fortifying nutrient Flour treatment agent
Potassium Lactate	It should be used in accordance with Section II.2.1).	Acidity regulator Flavour enhancer

<p>Potassium Metabisulfite</p>	<p>Potassium Metabisulfite should be used only for the following food items. The residual amount of Potassium Metabisulfite as sulfur dioxide should be less than</p> <ol style="list-style-type: none"> 1. Dried gourd shavings(which is sliced and dried of gourd removing its cores): 5.0g/kg 2. Molasses: 0.3g/kg 3. Starch syrup and other taffies: 0.20g/kg 4. Fruit wines: 0.350 g/kg 5. Fruit juice, concentrated fruit juice: 0.150g/kg(However, only a product which is drank or used by dilution more than 5 times) 6. Processed fruit/vegetable product: 0.030g/kg(However, in case of a product which is drank or used by dilution more than 5 times: 0.150g/kg) 7. Dried fruits: 1.0g/kg(However, the fruits(dried products only) which are edible food ingredients in 「The Korean Pharmacopoeia」(announced Ministry of Food and Drug Safety) or 「National Standard of Traditional Medicinal(Herbal and Botanical) Materials」(announced Ministry of Food and Drug Safety) are applied to a sulfur dioxide on these standards and 2.0g/kg in dried apricot, 0.20g/kg in dried coconut) 8. Dried vegetables, dried mushrooms: 0.50g/kg(However, the vegetables and mushrooms(dried products only) which are edible food ingredients in 「The Korean Pharmacopoeia」 (announced Ministry of Food and Drug Safety) or 「National Standard of Traditional Medicinal(Herbal and Botanical) Materials」(announced Ministry of Food and Drug Safety) are applied to a sulfur dioxide on these standards) 9. Dried agricultural/forest products(However, the plant ingredients excluding No.7, 8(dried products only) which are edible food ingredients in 「The Korean 	<p>Preservative Antioxidant</p>
---------------------------------------	--	-------------------------------------

Pharmacopoeia」(announced Ministry of Food and Drug Safety) or 「National Standard of Traditional Medicinal(Herbal and Botanical) Materials」(announced Ministry of Food and Drug Safety) and *Rehmannia glutinosa var.purpurea* are applied to a sulfur dioxide on these standards)

10. *Konjac* powder: 0.90g/kg
11. Shrimps: 0.10g/kg (peeled shrimp)
12. Frozen fresh crabs: 0.10g/kg (peeled crab)
13. Saccharidess: 0.020g/kg
14. Vinegars: 0.10g/kg
15. Dried potatoes: 0.50g/kg
16. Sauce: 0.30g/kg
17. Spice preparation: 0.20g/kg
18. Other processed fishery products(excluding shrimp, frozen fresh crab), processed peanut or nut products, pickled foods products, breads, fruit/vegetable beverages, carbonated beverages, confectionery, noddles, dumpling skin, dried fish/shellfish fillet products, candies, cocoa products or chocolates, other beverages, processed tuberos and corn vegetable product(excluding dried potato and konjac powder), processed pulse product, boiled foods(ingredients for agricultural foods only), Brandy, General Distilled Alcoholic Beverage, other alcoholic beverages, parboiled rice, jams, starch products, processed saccharide product, *Doenjang*(soybean paste) : 0.030g/kg
19. Processed cereal product(products of 100% corn germ for the manufacture of corn oil only): 0.20g/kg

Food additive	Use Level	Major functional class
Potassium Metaphosphate	It should be used in accordance with Section II.2.1).	Acidity regulator Raising agent
Potassium Nitrate	Potassium Nitrate should be used only for the following food items. The usage as nitrite ion should be 1. Processed meat products(excluding Meat Extract Product): 0.07g/kg 2. Cheeses: 0.05g/kg 3. Salted alaska cod's roe : 0.2g/kg	Colour retention agent Preservative
Potassium Phosphate, Dibasic	It should be used in accordance with Section II.2.1).	Acidity regulator Raising agent
Potassium Phosphate, Monobasic	It should be used in accordance with Section II.2.1).	Acidity regulator Raising agent Fortifying nutrient
Potassium Phosphate, Tribasic	It should be used in accordance with Section II.2.1).	Acidity regulator Raising agent Fortifying nutrient
Potassium Polyphosphate	It should be used in accordance with Section II.2.1).	Acidity regulator Raising agent

Food additive	Use Level	Major functional class
Potassium Pyrophosphate	It should be used in accordance with Section II.2.1).	Acidity regulator Raising agent
Potassium Sodium L-Tartrate	It should be used in accordance with Section II.2.1).	Acidity regulator

<p>Potassium Sorbate</p>	<p>Potassium Sorbate should be used only for the following food items. The usage as sorbic acid should be</p> <ol style="list-style-type: none"> 1. Cheeses: no more than 3.0g/kg(if it is used with propionic acid, sodium propionate, or calcium propionate, the sum of usage as propionic acid and sorbic acid should be no more than 3.0g/kg) 2. Processed meat products(excluding seasoned meats, ground meat product, processed rib product, meat extract product), processed fish meat products, salted and fermented sea urchin, peanut butter, imitation cheese: Not more than 2.0g/kg 3. Collagen casing: no more than 0.1g/kg 4. Salted and fermented seafood products(However, product which account for no more than 8% of salt only), korean-style <i>Doenjang</i>, <i>Doenjang</i>, <i>Gochujang</i>, mixed paste, <i>Chunjang</i>, <i>Cheonggukjang</i>(However, non-dried products only), dried fish and shellfish, boiled foods(ingredients for agricultural foods only), flour pastes, sauce: no more than 1.0g/kg(However, in the case of sauce, if it is used with Methyl p-Hydroxybenzoate or Ethyl p-Hydroxybenzoate, the sum of usage as sorbic acid and p-Hydroxybenzoic acid should be no more than 1.0g/kg, and the usage as p-Hydroxybenzoic acid should be no more than 0.2g/kg) 5. Aloe whole leaves(including Aloe gel) health functional food(However, in the case of using more than two kinds of health functional food materials, the usage applies proportion of the aloe whole leaves(including the aloe gel) health functional food content): no more than 1.0g/kg(if it is used with benzoic acid, sodium 	<p>Preservative</p>
---------------------------------	---	---------------------

benzoate, potassium benzoate or calcium benzoate, the sum of usage as sorbic acid and benzoic acid should be no more than 1.5g/kg and the usage as benzoic acid should be no more than 0.5g/kg)

6. Concentrated fruit juice, fruit/vegetable juice: no more than 1.0g/kg(if it is used with benzoic acid, sodium benzoate, potassium benzoate or calcium benzoate, the sum of usage as sorbic acid and benzoic acid should be no more than 1.0g/kg and the usage as benzoic acid should be no more than 0.6g/kg)
7. Carbonated beverages: no more than 0.5g/kg(If it is used with benzoic acid, sodium benzoate, potassium benzoate or calcium benzoate, the sum of usage as sorbic acid and benzoic acid should be no more than 0.6 g/kg, and the usage as sorbic acid should be no more than 0.5 g/kg)
8. Jams: no more than 1.0 g/kg(if it is used with benzoic acid, sodium benzoate, potassium benzoate, calcium benzoate, methyl p-hydroxybenzoate, ethyl p-hydroxybenzoate, propyl p-hydroxybenzoate, propionic acid, sodium propionate, or calcium propionate, the total usage of sorbic acid, benzoic acid, p-hydroxybenzoic acid, and propionic acid should be no more than 1.0 g/kg)
9. Dried fruits, tomato ketchup , Sugar-preserved food(excluding sugar-preserved dried foods): no more than 0.5g/kg.
10. Pickled food, **mayonnaise**: no more than 1.0g/kg(if it is used with benzoic acid, sodium benzoate, potassium benzoate or calcium benzoate, in that the total usage of benzoic acid and sorbic acid should be no more than 1.5 g/kg and the usage as benzoic

acid should be no more than 1.0 g/kg)

11. Fermented beverages(excluding pasteurized beverages): no more than 0.05g/kg.
12. Fruit wine, *Takju*(korean turbid rice wine), *Yakju*(korean clear rice wine): no more than 0.2g/kg.
13. Margarine: no more than 1.0g/kg(if it is used with benzoic acid, sodium benzoate, potassium benzoate, or calcium benzoate, the total usage of sorbic acid and the benzoic acid should be no more than 2.0g/kg and the usage as benzoic acid should be no more than 1.0 g/kg)
14. Processed saccharide product(only syrup and paste): Not more than 1.0g/kg
15. Spice preparation(excluding dried products): no more than 1.0g/kg
16. Health functional food(only liquid products, excluding aloe whole leaves(including Aloe gel) health functional food): no more than 2.0g/kg

Food additive	Use Level	Major functional class
Potassium Sulfate	It should be used in accordance with Section II.2.1).	Acidity regulator
L-Proline	It should be used in accordance with Section II.2.1).	Fortifying nutrient
Propionic acid	<p>Propionic Acid should be used only for the following food items and the function. The usage as propionic acid should be</p> <ol style="list-style-type: none"> 1. Breads: no more than 2.5g/kg 2. Cheeses: no more than 3.0g/kg(if it is used with sorbic acid, calcium sorbate, or potassium sorbate, the sum of usage as propionic acid and sorbic acid should be no more than 3.0g/kg) 3. Jams: no more than 1.0g/kg(if it is used with sorbic acid, potassium sorbic, calcium sorbic, benzoic acid, potassium benzoate, calcium benzoate, sodium benzoate, methyl p-hydroxybenzoate, or ethyl p-hydroxybenzoate, the sum of usage as propionic acid, sorbic acid, benzoic acid, and p-hydroxybenzoic acid should be no more than 1.0g/kg). 4. For flavoring 	Preservative Flavouring agent
Propyl Gallate	<p>Propyl Gallate should be used only for the following food items. The usage should be</p> <ol style="list-style-type: none"> 1. Edible fats and oils(excluding for imitation cheese and vegetable cream), Butters: no more than 0.1g/kg 	Antioxidant

Food additive	Use Level	Major functional class
<p>Propylene Glycol</p>	<p>The usage should be</p> <ol style="list-style-type: none"> 1. Dumplings : no more than 1.2% 2. Processed peanut or nut products : no more than 5% 3. Ice creams : no more than 2.5% 4. Other foods: no more than 2%(However, for the health functional food which is drank by dilution, it should be no more than 0.3% as diluted) <p><MFDS regulation 2019-1, 2019.7.1.>[Enforcement date: 2019.7.1.]</p> <p>If propylene glycol is used directly in the final product, it shall be used in the following foods only. However, if used as a diluent, emulsifier or stabilizer, it shall be used no more than 2% of the final product.</p> <ol style="list-style-type: none"> 1. Dumplings : no more than 1.2% 2. Processed peanut or Nut Products : no more than 2.5% 3. Ice creams : no more than 2.5% 4. Confectionaries, Candies, Chewing Gum, Flavored oil, Noodles, Liquid Tea, Other beverages, Sauces, Spice Products, Other Processed Products : no more than 2% 5. Breads, Rice Cakes, Froxen Confectionary Products, Chocolates, Processed Saccharide Product, Jams, Vegetable cream, Carbonated Beverages, Processed salt, Pickled Food Products, Alcoholic Beverages, Other Processed Agricultural Product, Capsules : no more than 1% 6. Health functional food : no more than 2%(However, in the case of the health functional food which is diluted and then consumed, it shall be no more than 0.3 %) 	<p>Emulsifier Humectant Stabilizer</p>
<p>Propylene Glycol Alginate</p>	<p>The Usage of Propylene Glycol Alginate should be no more than 1% of the food items.</p>	<p>Emulsifier Thickener Stabilizer</p>

Food additive	Use Level	Major functional class
Propylene Glycol Esters of Fatty Acids	It should be used in accordance with Section II.2.1).	Emulsifier
Protease	It should be used in accordance with Section II.2.1).	Enzyme preparations
Psyllium Seed Gum	It should be used in accordance with Section II.2.1).	Thickener Stabilizer
Pullulan	It should be used in accordance with Section II.2.1).	Coating agent
Pullulanase	It should be used in accordance with Section II.2.1).	Enzyme preparations
Purple Sweet Potato Color	<p>Purple sweet potato color should not be used in the food items listed below.</p> <ol style="list-style-type: none"> 1. Natural food[meat, fishes and shellfishes, fruits, vegetables, algae, Legume vegetables and pulses, and their simply processed food(peeled, cut, and etc.)] 2. Teas 3. Coffee 4. Hot pepper powder, shredded hot pepper 5. <i>Kimchi</i> products 6. <i>Gochujang</i>(hot pepper soy paste), seasoned hot pepper soy paste 7. Vinegars 8. Spice products(only the products containing hot pepper or hot pepper powder) 	Colour

Food additive	Use Level	Major functional class
Purple Yam Color	<p>Purple yam color should not be used in the food items listed below.</p> <ol style="list-style-type: none"> 1. Natural food[meat, fishes and shellfishes, fruits, vegetables, algae, Legume vegetables and pulses, and their simply processed food(peeled, cut, and etc.)] 2. Teas 3. Coffee 4. Hot pepper powder, shredded hot pepper 5. <i>Kimchi</i> products 6. <i>Gochujang</i>(hot pepper soy paste), seasoned hot pepper soy paste 7. Vinegars 8. Spice products(only the products containing hot pepper or hot pepper powder) 	Colour
Quercetin	It should be used in accordance with Section II.2.1).	Antioxidant
Quillaia Extract	It should be used in accordance with Section II.2.1).	Emulsifier
Red Cabbage Color	<p>Red cabbage color should not be used in the food items listed below.</p> <ol style="list-style-type: none"> 1. Natural food[meat, fishes and shellfishes, fruits, vegetables, algae, Legume vegetables and pulses, and their simply processed food(peeled, cut, and etc.)] 2. Teas 3. Coffee 4. Hot pepper powder, shredded hot pepper 5. <i>Kimchi</i> products 6. <i>Gochujang</i>(hot pepper soy paste), seasoned hot pepper soy paste 7. Vinegars 8. Spice products(only the products containing 	Colour

Food additive	Use Level	Major functional class
	hot pepper or hot pepper powder)	
Red Radish Color	<p>Red radish color should not be used in the food items listed below.</p> <ol style="list-style-type: none"> 1. Natural food[meat, fishes and shellfishes, fruits, vegetables, algae, Legume vegetables and pulses, and their simply processed food(peeled, cut, and etc.)] 2. Teas 3. Coffee 4. Hot pepper powder, shredded hot pepper 5. <i>Kimchi</i> products 6. <i>Gochujang</i>(hot pepper soy paste), seasoned hot pepper soy paste 7. Vinegars 8. Spice products(only the products containing hot pepper or hot pepper powder) 	Colour
D-Ribose	It should be used in accordance with Section II.2.1).	Sweetener
Rice Bran Wax	It should be used in accordance with Section II.2.1).	Coating agent

Food additive	Use Level	Major functional class
Rosin	It should be used in accordance with Section II.2.1).	Gum base
Rutin	<p>Rutin should not be used in the food items listed below.</p> <ol style="list-style-type: none"> 1. Natural food [meat, fishes and shellfishes, fruits, vegetables, algae, Legume vegetables and pulses, and their simply processed food(peeled, cut, and etc.)] 2. Teas 3. Coffee 4. Hot pepper powder, shredded hot pepper 5. <i>Kimchi</i> products 6. <i>Gochujang</i>(hot pepper soy paste), seasoned hot pepper soy paste 7. Vinegars 	Colour Antioxidant
Saffron Color	<p>Saffron color should not be used in the food items listed below.</p> <ol style="list-style-type: none"> 1. Natural food[meat, fishes and shellfishes, fruits, vegetables, algae, Legume vegetables and pulses, and their simply processed food(peeled, cut, and etc.)] 2. Teas 3. Coffee 4. Hot pepper powder, shredded hot pepper 5. <i>Kimchi</i> products 6. <i>Gochujang</i>(hot pepper soy paste), seasoned hot pepper soy paste 7. Vinegars 	Colour

Food additive	Use Level	Major functional class
Sandalwood Red	<p>Sandalwood red should not be used in the food items listed below.</p> <ol style="list-style-type: none"> 1. Natural food[meat, fishes and shellfishes, fruits, vegetables, algae, Legume vegetables and pulses, and their simply processed food(peeled, cut, and etc.)] 2. Teas 3. Coffee 4. Hot pepper powder, shredded hot pepper 5. <i>Kimchi</i> products 6. <i>Gochujang</i>(hot pepper soy paste), seasoned hot pepper soy paste 7. Vinegars 8. Spice products(only the products containing hot pepper or hot pepper powder) 	Colour
Seed Malt	It should be used in accordance with Section II.2.1).	Enzyme preparations
Sepia Color	<p>Sepia color should not be used in the food items listed below.</p> <ol style="list-style-type: none"> 1. Natural food[meat, fishes and shellfishes, fruits, vegetables, algae, Legume vegetables and pulses, and their simply processed food(peeled, cut, and etc.)] 2. Teas 3. Coffee 4. Hot pepper powder, shredded hot pepper 5. <i>Kimchi</i> products 6. <i>Gochujang</i>(hot pepper soy paste), seasoned hot pepper soy paste 7. Vinegars 	Colour
L-Serine	It should be used in accordance with Section II.2.1).	Fortifying nutrient

Food additive	Use Level	Major functional class
Sesame Seed Oil Unsaponified Matter	It should be used in accordance with Section II.2.1).	Antioxidant
Shea Nut Color	<p>Shea nut color should not be used in the food items listed below.</p> <ol style="list-style-type: none"> 1. Natural food[meat, fishes and shellfishes, fruits, vegetables, algae, Legume vegetables and pulses, and their simply processed food(peeled, cut, and etc.)] 2. Teas 3. Coffee 4. Hot pepper powder, shredded hot pepper 5. <i>Kimchi</i> products 6. <i>Gochujang</i>(hot pepper soy paste), seasoned hot pepper soy paste 7. Vinegars 	Colour
Shellac	It should be used in accordance with Section II.2.1).	Coating agent

Food additive	Use Level	Major functional class
Silicon Dioxide	<p>Silicon dioxide should be used only for anticaking agent, antifoaming agent and filtering aid. However, If it is used for a filtering aid, it should be removed before the final product is completed. If it is used for a anticaking agent, it should be used only for the following food items and the usage should be</p> <ol style="list-style-type: none"> 1. Processed milk cream(only powder products for vending machine) : no more than 1%(if it is used with magnesium silicate or calcium silicate, the sum of usage should be no more than 1%) 2. Powdered milks(only for vending machine) : no more than 1%(if it is used with magnesium silicate or calcium silicate, the sum of usage should be no more than 1%) 3. Edible salts : no more than 2% (if it is used with magnesium silicate or calcium silicate, the sum of usage should be no more than 2%) 4. Other foods: no more than 2% 	<p>Anticaking agent Filter aid Antifoaming agent</p>
Silicone Resin	<p>Silicone Resin should be used only for a antifoaming agent. The usage should be no more than 0.05g/kg of food items.</p>	<p>Antifoaming agent</p>
Smoke Flavours	<p>Smoke Flavors should be used for flavorings only. It should not be used for Beverages(excluding teas and coffee).</p>	<p>Flavouring agent</p>
Sodium Acetate	<p>It should be used in accordance with Section II.2.1).</p>	<p>Acidity regulator</p>
Sodium Alginate	<p>It should be used in accordance with Section II.2.1).</p>	<p>Emulsifier Thickener Stabilizer</p>

Food additive	Use Level	Major functional class
Sodium Aluminium Phosphate, Acidic	<p>It should be used in accordance with Section II.2.1).</p> <p><MFDS regulation 2018-53, 2018.6.29.> <u>[Enforcement date: 2019.7.1.]</u></p> <p>Sodium Aluminium Phosphate, Acidic should be used only for the following food items. The usage as aluminium should be</p> <ol style="list-style-type: none"> 1. Confectionery, mixes for confectionery, breads, mixes for breads, mixes for frying: no more than 0.1g/kg(if it is used with Aluminium Potassium Sulfate, Aluminium Ammonium Sulfate, Sodium Aluminium Phosphate, Basic, the total of usage as aluminium should be no more than 0.1g/kg) 	Acidity regulator Raising agent
Sodium Aluminium Phosphate, Basic	<p>It should be used in accordance with Section II.2.1).</p> <p><MFDS regulation 2018-53, 2018.6.29.> <u>[Enforcement date: 2019.7.1.]</u></p> <p>Sodium Aluminium Phosphate, Basic should be used only for the following food items. The usage as aluminium should be</p> <ol style="list-style-type: none"> 1. Confectionery, mixes for Confectionery, breads, mixes for breads, mixes for frying: no more than 0.1g/kg(if it is used with Aluminium Potassium Sulfate, Aluminium Ammonium Sulfate, Sodium Aluminium Phosphate, Acidic, the total of usage as aluminium should be no more than 0.1g/kg) 	Acidity regulator Emulsifier
Sodium L-Ascorbate	<p>It should be used in accordance with Section II.2.1).</p>	Fortifying nutrient Antioxidant

<p>Sodium Benzoate</p>	<p>Sodium Benzoate should be used only for the following food items. The usage as benzoic acid should be</p> <ol style="list-style-type: none"> 1. Fruit/vegetable beverages(excluding non-heated products): no more than 0.6g/kg(In the case of concentrated fruit juice, fruit/vegetable juice, if it is used with sorbic acid, potassium sorbate, or calcium sorbate, the sum of usage as benzoic acid and sorbic acid should be no more than 1.0 g/kg, and the usage of benzoic acid should be no more than 0.6g/kg) 2. Carbonated beverage: no more than 0.6g/kg(If it is used with sorbic acid, potassium sorbate or calcium sorbate, the sum of usage as benzoic acid and sorbic acid should be no more than 0.6g/kg, and the usage as sorbic acid should be no more than 0.5g/kg) 3. Other beverages(excluding powder products), Ginseng/red ginseng beverages: no more than 0.6g/kg(if it is used with ethyl ρ-hydroxybenzoate or methyl ρ-hydroxybenzoate, the sum of usage as benzoic acid and ρ-hydroxybenzoic acid should be no more than 0.6g/kg, and the usage as ρ-hydroxybenzoic acid should be no more than 0.1g/kg) 4. Korean-style soy sauce, brewed soy sauce, acid-hydrolyzed soy sauce, enzyme-hydrolyzed soy sauce, blended soy sauce: no more than 0.6g/kg(if it is used with ethyl ρ-hydroxybenzoate or Methyl ρ-hydroxybenzoate, the sum of usage as benzoic acid and ρ-hydroxybenzoic acid should be no more than 0.6g/kg, and the usage as ρ-hydroxybenzoic acid should be no more than 0.25g/kg) 5. Aloe whole leaves(including Aloe gel) health functional food(However, in the case of using 	<p>Preservative</p>
-------------------------------	---	---------------------

more than two kinds of health functional food materials, apply proportion of the aloe whole leaves(including the aloe gel) health functional food content): no more than 0.5g/kg(if it is used with sorbic acid, potassium sorbate, or calcium sorbate, the sum of usage as benzoic acid and sorbic acid should be no more than 1.5g/kg, and the usage of sorbic acid should be no more than 1.0g/kg)

6. Mayonnaise: no more than 1.0g/kg
7. Jams: no more than 1.0g/kg(if it is used with sorbic acid, potassium sorbate, calcium sorbate, methyl ρ -hydroxybenzoate, ethyl ρ -hydroxybenzoate, propionic acid, sodium propionate, or calcium propionate, the sum of usage as benzoic acid, sorbic acid, ρ -hydroxybenzoic acid, and propionic acid should be no more than 1.0 g/kg)
8. Mango chutney: no more than 0.25g/kg(if it is used with Methyl ρ -hydroxybenzoate or ethyl ρ -hydroxybenzoate, the sum of usage as benzoic acid and ρ -hydroxybenzoic acid should be no more than 0.25g/kg).
9. Margarine: no more than 1.0g/kg(if it is used with sorbic acid, potassium sorbate or calcium sorbate, the sum of usage as sorbic acid and benzoic acid should be no more than 2.0g/kg, and the usage as benzoic acid should be no more than 0.1g/kg)
10. Pickled food: no more than 1.0g/kg(if it is used with sorbic acid, potassium sorbate or calcium sorbate, the sum of usage as benzoic acid and sorbic acid should be no more than 1.5g/kg, and the usage of sorbic acid should be no more than 1.0g/kg)

Food additive	Use Level	Major functional class
Sodium Bicarbonate	It should be used in accordance with Section II.2.1).	Acidity regulator Raising agent Fortifying nutrient

<p>Sodium Bisulfite</p>	<p>Sodium Bisulfite should be used only for the following food items. The residual amount of Sodium Bisulfite as sulfur dioxide should be less than</p> <ol style="list-style-type: none"> 1. Dried gourd shavings(which is sliced and dried of gourd removing its cores): 5.0g/kg 2. Molasses: 0.3g/kg 3. Starch syrup and other taffies: 0.20g/kg 4. Fruit wines: 0.350g/kg 5. Fruit juice, concentrated fruit juice: 0.150g/kg(However, only a product which is drank or used by dilution more than 5 times) 6. Processed fruit/vegetable product: 0.030g/kg(However, in case of a product which is drank or used by dilution more than 5 times: 0.150g/kg) 7. Dried fruits: 1.0g/kg(However, the fruits(dried products only) which are edible food ingredients in 「The Korean Pharmacopoeia」(announced Ministry of Food and Drug Safety) or 「National Standard of Traditional Medicinal(Herbal and Botanical) Materials」(announced Ministry of Food and Drug Safety) are applied to a sulfur dioxide on these standards and 2.0g/kg in dried apricot, 0.20g/kg in dried coconut) 8. Dried vegetables, dried mushrooms: 0.50g/kg(However, the vegetables and mushrooms(dried products only) which are edible food ingredients in 「The Korean Pharmacopoeia」 (announced Ministry of Food and Drug Safety) or 「National Standard of Traditional Medicinal(Herbal and Botanical) Materials」(announced Ministry of Food and Drug Safety) are applied to a sulfur dioxide on these standards) 9. Dried agricultural/forest products(However, the plant ingredients excluding No.7, 8(dried products only) which are edible food ingredients in 「The Korean 	<p>Bleaching agent Preservative Antioxidant</p>
--------------------------------	---	---

Pharmacopoeia」(announced Ministry of Food and Drug Safety) or 「National Standard of Traditional Medicinal(Herbal and Botanical) Materials」(announced Ministry of Food and Drug Safety) and *Rehmannia glutinosa var.purpurea* are applied to a sulfur dioxide on these standards)

10. *Konjac* powder: 0.90g/kg
11. Shrimps: 0.10g/kg(peeled shrimp)
12. Frozen fresh crabs: 0.10g/kg(peeled crab)
13. Saccharidess: 0.020g/kg
14. Vinegars: 0.10g/kg
15. Dried potatoes: 0.50g/kg
16. Sauce: 0.30g/kg
17. Spice preparation: 0.20g/kg
18. Other processed fishery products(excluding shrimp, frozen fresh crab), processed peanut or nut products, pickled foods products, breads, fruit/vegetable beverages, carbonated beverages, confectionery, noddles, dumpling skin, dried fish/shellfish fillet products, candies, cocoa products or chocolates, other beverages, processed tuberos and corn vegetable product(excluding dried potato and konjac powder), processed pulse product, boiled foods(ingredients for agricultural foods only), Brandy, General Distilled Alcoholic Beverage, other alcoholic beverages, parboiled rice, jams, starch products, processed saccharide product, *Doenjang*(soybean paste) : 0.030g/kg
19. Processed cereal product(products of 100% corn germ for the manufacture of corn oil only): 0.20g/kg

Food additive	Use Level	Major functional class
Sodium Carbonate	It should be used in accordance with Section II.2.1).	Acidity regulator Raising agent Fortifying nutrient
Sodium Carboxymethyl Starch	The usage of Sodium Carboxymethyl Starch should be no more than 2% of the food items.(If it is used with Methylcellulose, Sodium Carboxymethylcellulose or Calcium Carboxymethylcellulose, the sum of usage should be no more than 2%. However, health functional foods are not restricted.)	Thickener Stabilizer
Sodium Carboxymethylcellulose	The usage of Sodium Carboxymethyl Starch should be no more than 2% of the food items.(If it is used with Methylcellulose, Sodium Carboxymethyl Starch or Calcium Carboxymethylcellulose, the sum of usage should be no more than 2%. However, health functional foods are not restricted.)	Thickener Stabilizer
Sodium Caseinate	It should be used in accordance with Section II.2.1).	Emulsifier Thickener Stabilizer
Sodium copper chlorophyllin	Sodium Copper Chlorophyllin should be used only for the following food items. The usage should be. The usage as copper should be 1. Kelp(anhydrous form): no more than 0.15g/kg 2. Preserved vegetables or fruits: no more than 0.1g/kg 3. Chewing gum and candies: no more than 0.05g/kg 4. Agar in canned green pea product: no more than 0.0004g/kg	Colour

Food additive	Use Level	Major functional class
Sodium Dehydroacetate	Sodium Dehydroacetate should be used only for the following food items. The usage as dehydroacetic acid should be 1. Cheeses, butters, margarine: no more than 0.5g/kg	Preservative
Sodium Diacetate	Sodium Diacetate should be used only for the following food items. The usage should be 1. Breads : no more than 0.4% 2. Edible fats and oils(excluding animal fats and oils, imitation cheese, vegetable cream), processed meat products (excluding meat extract product), egg products, and candies : no more than 0.1% 3. Sauces : no more than 0.25% 4. Soups and confectioneries : no more than 0.05%	Acidity regulator
Sodium Erythorbate	Sodium Erythorbate should only be used for antioxidant.	Antioxidant
Sodium Ferric Pyrophosphate	It should be used in accordance with Section II.2.1).	Fortifying nutrient
Sodium Ferrocyanide	Sodium ferrocyanide should be used for edible salts only. The usage as ferrocyanide ion should be no more than 0.010g/kg.(If it is used with potassium ferrocyanides or calcium ferrocyanides, the sum of usage as ferrocyanide ion should be no more than 0.010g/kg for edible salts.	Anticaking agent
Sodium Ferrous Citrate	Sodium Ferrous Citrate should be used only for the following food items. 1. Foods for special medical purposes 2. Health functional food	Fortifying nutrient

Food additive	Use Level	Major functional class
Sodium Fluoride	Sodium Fluoride should be used only for the following food item. 1. Foods for patient(only Balanced nutritional food for patient)	Fortifying nutrient
Sodium Gluconate	It should be used in accordance with Section II.2.1).	Acidity regulator Emulsifier Fortifying nutrient

<p>Sodium Hydrosulfite</p>	<p>Sodium Hydrosulfite should be used only for the following food items. The residual amount of Sodium Hydrosulfite as sulfur dioxide should be less than</p> <ol style="list-style-type: none"> 1. Dried gourd shavings(which is sliced and dried of gourd removing its cores): 5.0g/kg 2. Molasses: 0.3g/kg 3. Starch syrup and other taffies: 0.20g/kg 4. Fruit wines: 0.350g/kg 5. Fruit juice, concentrated fruit juice: 0.150g/kg(However, only a product which is drank or used by dilution more than 5 times) 6. Processed fruit/vegetable product: 0.030g/kg(However, in case of a product which is drank or used by dilution more than 5 times: 0.150g/kg) 7. Dried fruits: 1.0g/kg(However, the fruits(dried products only) which are edible food ingredients in 「The Korean Pharmacopoeia」(announced Ministry of Food and Drug Safety) or 「National Standard of Traditional Medicinal(Herbal and Botanical) Materials」(announced Ministry of Food and Drug Safety) are applied to a sulfur dioxide on these standards and 2.0g/kg in dried apricot, 0.20g/kg in dried coconut) 8. Dried vegetables, dried mushrooms: 0.50g/kg(However, the vegetables and mushrooms(dried products only) which are edible food ingredients in 「The Korean Pharmacopoeia」 (announced Ministry of Food and Drug Safety) or 「National Standard of Traditional Medicinal(Herbal and Botanical) Materials」(announced Ministry of Food and Drug Safety) are applied to a sulfur dioxide on these standards) 9. Dried agricultural/forest products(However, the plant ingredients excluding No.7, 8(dried products only) which are edible food ingredients in 「The Korean 	<p>Bleaching agent Preservative Antioxidant</p>
-----------------------------------	---	---

Pharmacopoeia」(announced Ministry of Food and Drug Safety) or 「National Standard of Traditional Medicinal(Herbal and Botanical) Materials」(announced Ministry of Food and Drug Safety) and *Rehmannia glutinosa var.purpurea* are applied to a sulfur dioxide on these standards)

10. *Konjac* powder: 0.90g/kg
11. Shrimps: 0.10g/kg(peeled shrimp)
12. Frozen fresh crabs: 0.10g/kg(peeled crab)
13. Saccharidess: 0.020g/kg
14. Vinegars: 0.10g/kg
15. Dried potatoes: 0.50g/kg
16. Sauce: 0.30g/kg
17. Spice preparation: 0.20g/kg
18. Other processed fishery products(excluding shrimp, frozen fresh crab), processed peanut or nut products, pickled foods products, breads, fruit/vegetable beverages, carbonated beverages, confectionery, noddles, dumpling skin, dried fish/shellfish fillet products, candies, cocoa products or chocolates, other beverages, processed tuberos and corn vegetable product(excluding dried potato and konjac powder), processed pulse product, boiled foods(ingredients for agricultural foods only), Brandy, General Distilled Alcoholic Beverage, other alcoholic beverages, parboiled rice, jams, starch products, processed saccharide product, *Doenjang*(soybean paste) : 0.030g/kg
19. Processed cereal product(products of 100% corn germ for the manufacture of corn oil only): 0.20g/kg

Food additive	Use Level	Major functional class
Sodium Hydroxide	Sodium Hydroxide should be neutralized or removed before the final product is completed.	Acidity regulator manufacturing solvent
Sodium Hydroxide Solution	Sodium Hydroxide Solution should be neutralized or removed before the final product is completed.	Acidity regulator manufacturing solvent
Sodium Hypochlorite	Sodium Hypochlorite should be used for sterilization of foods such as fruits and vegetables, and etc and it should be removed before the final product is completed. However, It should not be used for sesame.	Sterilizing agent
Sodium Iron Chlorophyllin	Sodium Iron Chlorophyllin should not be used in the food items listed below. <ol style="list-style-type: none"> 1. Natural food[meat, fishes and shellfishes, fruits, vegetables, algae, Legume vegetables and pulses, and their simply processed food(peeled, cut, and etc.)] 2. Teas 3. Coffee 4. Hot pepper powder, shredded hot pepper 5. <i>Kimchi</i> products 6. <i>Gochujang</i>(hot pepper soy paste), seasoned hot pepper soy paste 7. Vinegars 	Colour
Sodium Lactate	It should be used in accordance with Section II.2.1).	Acidity regulator Flavour enhancer Emulsifier Fortifying

Food additive	Use Level	Major functional class
		nutrient
Sodium Lauryl Sulfate	Sodium Lauryl Sulfate should be used only for the following food item. 1. Health functional foods, capsules	Emulsifier
Sodium DL-Malate	It should be used in accordance with Section II.2.1).	Acidity regulator Raising agent

<p>Sodium Metabisulfite</p>	<p>Sodium Metabisulfite should be used only for the following food items. The residual amount of Sodium Metabisulfite as sulfur dioxide should be less than</p> <ol style="list-style-type: none"> 1. Dried gourd shavings(which is sliced and dried of gourd removing its cores): 5.0g/kg 2. Molasses: 0.3g/kg 3. Starch syrup and other taffies: 0.20g/kg 4. Fruit wines: 0.350g/kg 5. Fruit juice, concentrated fruit juice: 0.150g/kg(However, only a product which is drank or used by dilution more than 5 times) 6. Processed fruit/vegetable product: 0.030g/kg(However, in case of a product which is drank or used by dilution more than 5 times: 0.150g/kg) 7. Dried fruits: 1.0g/kg(However, the fruits(dried products only) which are edible food ingredients in 「The Korean Pharmacopoeia」(announced Ministry of Food and Drug Safety) or 「National Standard of Traditional Medicinal(Herbal and Botanical) Materials」(announced Ministry of Food and Drug Safety) are applied to a sulfur dioxide on these standards and 2.0g/kg in dried apricot, 0.20g/kg in dried coconut) 8. Dried vegetables, dried mushrooms: 0.50g/kg(However, the vegetables and mushrooms(dried products only) which are edible food ingredients in 「The Korean Pharmacopoeia」 (announced Ministry of Food and Drug Safety) or 「National Standard of Traditional Medicinal(Herbal and Botanical) Materials」(announced Ministry of Food and Drug Safety) are applied to a sulfur dioxide on these standards) 9. Dried agricultural/forest products(However, the plant ingredients excluding No.7, 8(dried products only) which are edible food ingredients in 「The Korean 	<p>Bleaching agent Preservative Acidity regulator</p>
------------------------------------	---	---

Pharmacopoeia」(announced Ministry of Food and Drug Safety) or 「National Standard of Traditional Medicinal(Herbal and Botanical) Materials」(announced Ministry of Food and Drug Safety) and *Rehmannia glutinosa var.purpurea* are applied to a sulfur dioxide on these standards)

10. *Konjac* powder: 0.90g/kg
11. Shrimps: 0.10g/kg(peeled shrimp)
12. Frozen fresh crabs: 0.10g/kg(peeled crab)
13. Saccharidess: 0.020g/kg
14. Vinegars: 0.10g/kg
15. Dried potatoes: 0.50g/kg
16. Sauce: 0.30g/kg
17. Spice preparation: 0.20g/kg
18. Other processed fishery products(excluding shrimp, frozen fresh crab), processed peanut or nut products, pickled foods products, breads, fruit/vegetable beverages, carbonated beverages, confectionery, noddles, dumpling skin, dried fish/shellfish fillet products, candies, cocoa products or chocolates, other beverages, processed tuberos and corn vegetable product(excluding dried potato and konjac powder), processed pulse product, boiled foods(ingredients for agricultural foods only), Brandy, General Distilled Alcoholic Beverage, other alcoholic beverages, parboiled rice, jams, starch products, processed saccharide product, *Doenjang*(soybean paste) : 0.030g/kg
19. Processed cereal product(products of 100% corn germ for the manufacture of corn oil only): 0.20g/kg

Food additive	Use Level	Major functional class
Sodium Metaphosphate	It should be used in accordance with Section II.2.1).	Acidity regulator Raising agent
Sodium Metasilicate	Sodium Metasilicate should be used only for edible fats and oils(excluding animal fats and oils, imitation cheese, vegetable oils) as a filter aid and it should be removed before the final product is completed.	Filter aid
Sodium Methoxide	Sodium methoxide should be used only for processed oils and fats. However, It should be degraded before final products is completed. Also, methyl alcohol should be removed, which is formatted as residues.	manufacturing solvent
Sodium Molybdate	Sodium Molybdate should be used only for the following food items. 1. Foods for special medical purposes 2. Health functional food	Fortifying nutrient
Sodium Nitrate	Sodium Nitrate should be used only for the following food items. The usage as residual nitrite ion should be 1. Processed meat products(excluding meat extract product): 0.07g/kg 2. Cheese: 0.05g/kg	Colour retention agent Preservative

Food additive	Use Level	Major functional class
Sodium Nitrite	Sodium Nitrite should be used only for the following food items. The usage as residual nitrite ion should be <ol style="list-style-type: none"> 1. Processed meat products(excluding meat extract product): 0.07g/kg 2. Fish sausages: no more than 0.05g/kg 3. <i>myeongnan-jeot</i>(salted-fermented Alaska pollack roe) and <i>salmon roe-jeot</i>: no more than 0.005g/kg 	Colour retention agent Preservative
Sodium Oleate	It should be used in accordance with Section II.2.1).	Coating agent
Sodium Pantothenate	It should be used in accordance with Section II.2.1).	Fortifying nutrient
Sodium Phosphate, Dibasic	It should be used in accordance with Section II.2.1).	Acidity regulator Raising agent Fortifying nutrient
Sodium Phosphate, Monobasic	It should be used in accordance with Section II.2.1).	Acidity regulator Raising agent Fortifying nutrient
Sodium Phosphate, Tribasic	It should be used in accordance with Section II.2.1).	Acidity regulator Raising agent Fortifying nutrient

Food additive	Use Level	Major functional class
Sodium Polyacrylate	The usage of Sodium Polyacrylate should be no more than 0.2% of the food items.	Thickener Stabilizer
Sodium Polyphosphate	It should be used in accordance with Section II.2.1).	Acidity regulator Raising agent
Sodium Propionate	Sodium Propionate should be used only for the following food items. The usage as propionic acid should be <ol style="list-style-type: none"> 1. Breads: no more than 2.5g/kg 2. Cheeses: no more than 3.0g/kg(if it is used with sorbic acid, calcium sorbate, or potassium sorbate, the sum of usage as propionic acid and sorbic acid should be no more than 3.0g/kg) 3. Jams: no more than 1.0g/kg(if it is used with sorbic acid, potassium sorbic, calcium sorbic, benzoic acid, potassium benzoate, calcium benzoate, sodium benzoate, methyl p-hydroxybenzoate, or ethyl p-hydroxybenzoate, the sum of usage as propionic acid, sorbic acid, benzoic acid, and p-hydroxybenzoic acid should be no more than 1.0g/kg). 	Preservative
Sodium Pyrophosphate	It should be used in accordance with Section II.2.1).	Acidity regulator Raising agent

<p>Sodium Saccharin</p>	<p>Sodium Saccharin should be used only for the following food items. The usage should be</p> <ol style="list-style-type: none"> 1. Salted and fermented seafood products, pickled food products, boiled foods: no more than 1.0g/kg 2. <i>Kimchi</i> products: no more than 0.2g/kg 3. Beverages(excluding fermented beverages, ginseng/red ginseng beverages, teas) : no more than 0.2g/kg (However, only a product which is drank or used by dilution more than 5 times: no more than 1.0g/kg) 4. Processed fish meat products: no more than 0.1g/kg 5. Cereals: no more than 0.1g/kg 6. Puffed rice: no more than 0.5g/kg 7. Foods for special medical purposes: no more than 0.2g/kg 8. Weight control formulas: no more than 0.3g/kg 9. Health functional food: no more than 1.2g/kg 10. Chewing gum: no more than 1.2g/kg 11. Jams: no more than 0.2g/kg 12. Soy sauces and pastes: no more than 0.2g/kg 13. Sauce: no more than 0.16g/kg 14. Tomato ketchup: no more than 0.16g/kg 15. <i>Takju</i>(turbid rice wine): no more than 0.08g/kg 16. <i>Soju</i>(Korean kistilled spirits): no more than 0.08g/kg 17. Fruit wines: no more than 0.08g/kg 18. Other cocoa products, Chocolates: no more than 0.5g/kg 19. Breads: no more than 0.17g/kg 20. Confectioneries: no more than 0.1g/kg 21. Candies: no more than 0.5g/kg 22. Frozen confectionery products: no more than 0.1g/kg 23. Ice creams: no more than 0.1g/kg 24. Seasoned dried fish/shellfish fillet: no more 	<p>Sweetener</p>
--------------------------------	--	------------------

than 0.1g/kg

25. Rice cakes: no more than 0.2g/kg

26. Composite seasoning: no more than 1.5g/kg

27. Mayonnaise: no more than 0.16g/kg

28. Processed fruit/vegetable product: no more than 0.2g/kg

29. Maize(only boiled or steamed): no more than 0.2g/kg

30. Processed Saccharide products: no more than 0.3g/kg

Food additive	Use Level	Major functional class
Sodium Selenate	Sodium Selenate should be used only for the following items 1. Milk formulas, infant formulas, follow-up formulas 2. Food for special medical purposes 3. Health functional food	Fortifying nutrient
Sodium Selenite	Sodium Selenite should be used only for the following items 1. Milk formulas, infant formulas, follow-up formulas 2. Food for special medical purposes 3. Health functional food	Fortifying nutrient
Sodium Sesquicarbonate	It should be used in accordance with Section II.2.1).	Acidity regulator Raising agent
Sodium Silicoaluminate	The usage of Sodium Silicoaluminate should be no more than 2% of the food items.	Anticaking agent
	<MFDS regulation 2018-53, 2018.6.29.> [Enforcement date: 2019.7.1.] Sodium Silicoaluminate should be used only for the following food items. The usage as a aluminium should be 1. Processed edible salt: no more than 1.0g/kg 2. Other beverages: no more than 0.4g/kg 3. Vegetable cream: no more than 0.6g/kg 4. Other processed cocoa product: no more than 0.5g/kg 5. Composite seasoning: no more than 1.0g/kg	

Food additive	Use Level	Major functional class
Sodium Stearoyl Lactylate	<p>Sodium Stearoyl Lactylate should be used only for the following food items.</p> <ol style="list-style-type: none"> 1. Breads and mixes for bread 2. Noodles, dumpling skin 3. Vegetable cream 4. Sauce 5. Cheeses 6. Confectionery(excluding <i>Hangwa</i>(korean traditional confectionery)) 	Emulsifier
Sodium Sulfate	It should be used in accordance with Section II.2.1).	Acidity regulator Fortifying nutrient

<p>Sodium Sulfit</p>	<p>Sodium Sulfit should be used only for the following food items. The residual amount of Sodium Sulfit as sulfur dioxide should be less than</p> <ol style="list-style-type: none"> 1. Dried gourd shavings(which is sliced and dried of gourd removing its cores): 5.0g/kg 2. Molasses: 0.3g/kg 3. Starch syrup and other taffies: 0.20g/kg 4. Fruit wines: 0.350g/kg 5. Fruit juice, concentrated fruit juice: 0.150g/kg(However, only a product which is drank or used by dilution more than 5 times) 6. Processed fruit/vegetable product: 0.030g/kg(However, in case of a product which is drank or used by dilution more than 5 times: 0.150g/kg) 7. Dried fruits: 1.0g/kg(However, the fruits(dried products only) which are edible food ingredients in 「The Korean Pharmacopoeia」(announced Ministry of Food and Drug Safety) or 「National Standard of Traditional Medicinal(Herbal and Botanical) Materials」(announced Ministry of Food and Drug Safety) are applied to a sulfur dioxide on these standards and 2.0g/kg in dried apricot, 0.20g/kg in dried coconut) 8. Dried vegetables, dried mushrooms: 0.50g/kg(However, the vegetables and mushrooms(dried products only) which are edible food ingredients in 「The Korean Pharmacopoeia」 (announced Ministry of Food and Drug Safety) or 「National Standard of Traditional Medicinal(Herbal and Botanical) Materials」(announced Ministry of Food and Drug Safety) are applied to a sulfur dioxide on these standards) 9. Dried agricultural/forest products(However, the plant ingredients excluding No.7, 8(dried products only) which are edible food ingredients in 「The Korean Pharmacopoeia」(announced Ministry of Food and 	<p>Bleaching agent Preservative Antioxidant</p>
-----------------------------	---	---

Drug Safety) or 「National Standard of Traditional Medicinal(Herbal and Botanical) Materials」(announced Ministry of Food and Drug Safety) and *Rehmannia glutinosa var.purpurea* are applied to a sulfur dioxide on these standards)

10. *Konjac* powder: 0.90g/kg
11. Shrimps: 0.10g/kg(peeled shrimp)
12. Frozen fresh crabs: 0.10g/kg(peeled crab)
13. Saccharidess: 0.020g/kg
14. Vinegars: 0.10g/kg
15. Dried potatoes: 0.50g/kg
16. Sauce: 0.30g/kg
17. Spice preparation: 0.20g/kg
18. Other processed fishery products(excluding shrimp, frozen fresh crab), processed peanut or nut products, pickled foods products, breads, fruit/vegetable beverages, carbonated beverages, confectionery, noddles, dumpling skin, dried fish/shellfish fillet products, candies, cocoa products or chocolates, other beverages, processed tuberous and corn vegetable product(excluding dried potato and konjac powder), processed pulse product, boiled foods(ingredients for agricultural foods only), Brandy, General Distilled Alcoholic Beverage, other alcoholic beverages, parboiled rice, jams, starch products, processed saccharide product, *Doenjang*(soybean paste) : 0.030g/kg
19. Processed cereal product(products of 100% corn germ for the manufacture of corn oil only): 0.20g/kg

<p>Sorbic Acid</p>	<p>Sorbic Acid should be used only for the following food items. The usage as sorbic acid should be</p> <ol style="list-style-type: none"> 1. Cheeses: no more than 3.0g/kg(if it is used with propionic acid, sodium propionate, or calcium propionate, the sum of usage as propionic acid and sorbic acid should be no more than 3.0g/kg) 2. Processed meat products(excluding seasoned meats, ground meat product, processed rib product, meat extract product), processed fish meat products, salted and fermented sea urchin, peanut butter, imitation cheese: Not more than 2.0g/kg 3. Collagen casing: no more than 0.1g/kg 4. Salted and fermented seafood products(However, product which account for no more than 8% of salt only), korean-style <i>Doenjang</i>, <i>Doenjang</i>, <i>Gochujang</i>, mixed paste, <i>Chunjang</i>, <i>Cheonggukjang</i>(However, non-dried products only), dried fish and shellfish, boiled foods(ingredients for agricultural foods only), flour pastes, sauce: no more than 1.0g/kg(However, in the case of sauce, if it is used with Methyl p-Hydroxybenzoate or Ethyl p-Hydroxybenzoate, the sum of usage as sorbic acid and p-Hydroxybenzoic acid should be no more than 1.0g/kg, and the usage as p-Hydroxybenzoic acid should be no more than 0.2g/kg) 5. Aloe whole leaves(including Aloe gel) health functional food(However, in the case of using more than two kinds of health functional food materials, the usage applies proportion of the aloe whole leaves(including the aloe gel) health functional food content): no more than 1.0g/kg(if it is used with benzoic acid, sodium benzoate, potassium benzoate or calcium 	<p>Preservative</p>
---------------------------	---	---------------------

benzoate, the sum of usage as sorbic acid and benzoic acid should be no more than 1.5g/kg and the usage as benzoic acid should be no more than 0.5g/kg)

6. Concentrated fruit juice, fruit/vegetable juice: no more than 1.0g/kg(if it is used with benzoic acid, sodium benzoate, potassium benzoate or calcium benzoate, the sum of usage as sorbic acid and benzoic acid should be no more than 1.0g/kg and the usage as benzoic acid should be no more than 0.6g/kg)
7. Carbonated beverages: no more than 0.5g/kg(If it is used with benzoic acid, sodium benzoate, potassium benzoate or calcium benzoate, the sum of usage as sorbic acid and benzoic acid should be no more than 0.6 g/kg, and the usage as sorbic acid should be no more than 0.5 g/kg)
8. Jams: no more than 1.0 g/kg(if it is used with benzoic acid, sodium benzoate, potassium benzoate, calcium benzoate, methyl p-hydroxybenzoate, ethyl p-hydroxybenzoate, propyl p-hydroxybenzoate, propionic acid, sodium propionate, or calcium propionate, the total usage of sorbic acid, benzoic acid, p-hydroxybenzoic acid, and propionic acid should be no more than 1.0 g/kg)
9. Dried fruits, tomato ketchup , Sugar-preserved food(excluding sugar-preserved dried foods): no more than 0.5g/kg.
10. Pickled food, **mayonnaise**: 1.0g/kg(if it is used with benzoic acid, sodium benzoate, potassium benzoate or calcium benzoate, in that the total usage of benzoic acid and sorbic acid should be no more than 1.5 g/kg and the usage as benzoic acid should be no more than 1.0 g/kg)

11. Fermented beverages(excluding pasteurized beverages): no more than 0.05g/kg.
12. Fruit wine, *Takju*(korean turbid rice wine), *Yakju*(korean clear rice wine): no more than 0.2g/kg.
13. Margarine: no more than 1.0g/kg(if it is used with benzoic acid, sodium benzoate, potassium benzoate, or calcium benzoate, the total usage of sorbic acid and the benzoic acid should be no more than 2.0g/kg and the usage as benzoic acid should be no more than 1.0 g/kg)
14. Processed saccharide product(only syrup and paste): Not more than 1.0g/kg
15. Spice preparation(excluding dried products): no more than 1.0g/kg
16. Health functional food(only liquid products, excluding aloe whole leaves(including Aloe gel) health functional food): no more than 2.0g/kg

Food additive	Use Level	Major functional class
Sorbitan Esters of Fatty Acids	It should be used in accordance with Section II.2.1).	Emulsifier Gum base
D-Sorbitol	It should be used in accordance with Section II.2.1).	Sweetener Humectant
D-Sorbitol Solution	It should be used in accordance with Section II.2.1).	Sweetener Humectant
Spice Oleoresins	Spice Oleoresins should not be used in the food items listed below. <ol style="list-style-type: none"> 1. Natural food[meat, fishes and shellfishes, fruits, vegetables, algae, Legume vegetables and pulses, and their simply processed food(peeled, cut, and etc.)] 2. Hot pepper powder, shredded hot pepper 3. <i>Kimchi</i> products 4. <i>Gochujang</i>(hot pepper soy paste), seasoned hot pepper soy paste 5. Vinegars 	Flavour enhancer
Spirulina Color	Spirulina color should not be used in the food items listed below. <ol style="list-style-type: none"> 1. Natural food[meat, fishes and shellfishes, fruits, vegetables, algae, Legume vegetables and pulses, and their simply processed food(peeled, cut, and etc.)] 2. Teas 3. Coffee 4. Hot pepper powder, shredded hot pepper 5. <i>Kimchi</i> products 6. <i>Gochujang</i>(hot pepper soy paste), seasoned hot pepper soy paste 7. Vinegars 	Colour
Stearic Acid	It should be used in accordance with Section II.2.1).	manufacturing solvent

Food additive	Use Level	Major functional class
Steviol glycoside	<p>Steviol glycoside should not be used in the food items listed below.</p> <ol style="list-style-type: none"> 1. Sugars 2. Glucose 3. Starch syrup 4. Honeys 	Sweetener
Succinic Acid	It should be used in accordance with Section II.2.1).	Acidity regulator Flavour enhancer
Sucralose	<p>Sucralose should be used only for the following food items. The usage should be</p> <ol style="list-style-type: none"> 1. Confectioneries: no more than 1.8g/kg 2. Chewing gum: no more than 2.6g/kg 3. Jams: no more than 0.4g/kg 4. Beverages, processed milk, fermented milks: no more than 0.40g/kg(However, the product that is to be diluted before drinking is based on the diluted form) 5. Sugar substitute product: no more than 12g/kg 6. Cereals: no more than 1.0g/kg 7. Foods for special medical purposes: no more than 0.4g/kg 8. Weight control formulas: no more than 0.32g/kg 9. Other foods: no more than 0.58g/kg 10. Health functional food: no more than 1.25g/kg 	Sweetener
Sucrose Esters of Fatty Acids	It should be used in accordance with Section II.2.1).	Emulsifier Gum base

<p>Sulfur Dioxide</p>	<p>Sulfur Dioxide should be used only for the following food items. The residual amount of Sulfur Dioxide as sulfur dioxide should be less than</p> <ol style="list-style-type: none"> 1. Dried gourd shavings(which is sliced and dried of gourd removing its cores): 5.0g/kg 2. Molasses: 0.3g/kg 3. Starch syrup and other taffies: 0.20g/kg 4. Fruit wines: 0.350g/kg 5. Fruit juice, concentrated fruit juice: 0.150g/kg(However, only a product which is drank or used by dilution more than 5 times) 6. Processed fruit/vegetable product: 0.030g/kg(However, in case of a product which is drank or used by dilution more than 5 times: 0.150g/kg) 7. Dried fruits: 1.0g/kg(However, the fruits(dried products only) which are edible food ingredients in 「The Korean Pharmacopoeia」(announced Ministry of Food and Drug Safety) or 「National Standard of Traditional Medicinal(Herbal and Botanical) Materials」(announced Ministry of Food and Drug Safety) are applied to a sulfur dioxide on these standards and 2.0g/kg in dried apricot, 0.20g/kg in dried coconut) 8. Dried vegetables, dried mushrooms: 0.50g/kg(However, the vegetables and mushrooms(dried products only) which are edible food ingredients in 「The Korean Pharmacopoeia」 (announced Ministry of Food and Drug Safety) or 「National Standard of Traditional Medicinal(Herbal and Botanical) Materials」(announced Ministry of Food and Drug Safety) are applied to a sulfur dioxide on these standards) 9. Dried agricultural/forest products(However, the plant ingredients excluding No.7, 8(dried products only) which are edible food ingredients in 「The Korean Pharmacopoeia」(announced Ministry of Food and 	<p>Bleaching agent Preservative Antioxidant</p>
------------------------------	---	---

Drug Safety) or 「National Standard of Traditional Medicinal(Herbal and Botanical) Materials」(announced Ministry of Food and Drug Safety) and *Rehmannia glutinosa var.purpurea* are applied to a sulfur dioxide on these standards)

10. *Konjac* powder: 0.90g/kg
11. Shrimps: 0.10g/kg(peeled shrimp)
12. Frozen fresh crabs: 0.10g/kg(peeled crab)
13. Saccharidess: 0.020g/kg
14. Vinegars: 0.10g/kg
15. Dried potatoes: 0.50g/kg
16. Sauce: 0.30g/kg
17. Spice preparation: 0.20g/kg
18. Other processed fishery products(excluding shrimp, frozen fresh crab), processed peanut or nut products, pickled foods products, breads, fruit/vegetable beverages, carbonated beverages, confectionery, noddles, dumpling skin, dried fish/shellfish fillet products, candies, cocoa products or chocolates, other beverages, processed tuberous and corn vegetable product(excluding dried potato and konjac powder), processed pulse product, boiled foods(ingredients for agricultural foods only), Brandy, General Distilled Alcoholic Beverage, other alcoholic beverages, parboiled rice, jams, starch products, processed saccharide product, *Doenjang*(soybean paste) : 0.030g/kg
19. Processed cereal product(products of 100% corn germ for the manufacture of corn oil only): 0.20g/kg

Food additive	Use Level	Major functional class
Sulfuric Acid	Sulfuric Acid should be neutralized or removed before the final product is completed.	manufacturing solvent
Tagetes Extract	<p>Tagetes Extract should not be used in the food items listed below.</p> <ol style="list-style-type: none"> 1. Natural food[meat, fishes and shellfishes, fruits, vegetables, algae, Legume vegetables and pulses, and their simply processed food(peeled, cut, and etc.)] 2. Teas 3. Coffee 4. Hot pepper powder, shredded hot pepper 5. <i>Kimchi</i> products 6. <i>Gochujang</i>(hot pepper soy paste), seasoned hot pepper soy paste 7. Vinegars 	Colour
Talc	<p>Talc should be used only for manufacturing food, chewing gum, filtering aid(filtering, decolorization, deodorization, refining etc)and surface-finishing agent for tablets. However, if it is used for filtering aid, it should be removed before the final product is completed.</p> <ol style="list-style-type: none"> 1. The sum of residues should be no more than 0.5%(if it is used with other insoluble mineral substances such as Diatomaceous Earth, Kaolin, Bentonite, Acid Clay, Perlite, Active Carbon etc, the sum of residues should be 0.5%) 2. the usage of Chewing gum: no more than 5.0% 	Filter aid Gum base Surface-finishing agent

Food additive	Use Level	Major functional class
Tamarind Color	<p>Tamarind Color should not be used in the food items listed below.</p> <ol style="list-style-type: none"> 1. Natural food[meat, fishes and shellfishes, fruits, vegetables, algae, Legume vegetables and pulses, and their simply processed food(peeled, cut, and etc.)] 2. Teas 3. Coffee 4. Hot pepper powder, shredded hot pepper 5. <i>Kimchi</i> products 6. <i>Gochujang</i>(hot pepper soy paste), seasoned hot pepper soy paste 7. Vinegars 	Colour
Tamarind Gum	It should be used in accordance with Section II.2.1).	Thickener Stabilizer
Tannase	It should be used in accordance with Section II.2.1).	Enzyme preparations
Tannic Acid	It should be used in accordance with Section II.2.1).	Flavour enhancer
Tara Gum	It should be used in accordance with Section II.2.1).	Thickener Stabilizer
DL-Tartaric Acid	It should be used in accordance with Section II.2.1).	Acidity regulator
L-Tartaric Acid	It should be used in accordance with Section II.2.1).	Acidity regulator
Taurine	It should be used in accordance with Section II.2.1).	Fortifying nutrient
Tea Catechin	It should be used in accordance with Section II.2.1).	Antioxidant
Tea Extract	It should be used in accordance with Section II.2.1).	Antioxidant

Food additive	Use Level	Major functional class
Thaumatococcus	It should be used in accordance with Section II.2.1).	Sweetener
L-Theanine	It should be used in accordance with Section II.2.1).	Fortifying nutrient
DL-Threonine	It should be used in accordance with Section II.2.1).	Fortifying nutrient
L-Threonine	It should be used in accordance with Section II.2.1).	Fortifying nutrient

<p>Titanium Dioxide</p>	<p>Titanium dioxide should not be used in the food items listed below.</p> <ol style="list-style-type: none"> 1. Natural food[meat, fishes and shellfishes, fruits, vegetables, algae, Legume vegetables and pulses, and their simply processed food(peeled, cut, and etc.)] 2. Loaf bread and sponge cake 3. Cocoa mass, cocoa butter and cocoa powder 4. Jams 5. Milk products(excluding Ice creams, and Ice cream mixes) 6. Processed meat products(excluding sausages, meat extract products) 7. Egg product 8. Processed fish meat products(excluding fish sausage) 9. Soybean curds, <i>Muk</i>(starch jellies) 10. Edible fats and oils(excluding imitation cheese, vegetable cream, and other edible fat and oil products) 11. Noodles 12. Teas 13. Coffee 14. Fruit/vegetable beverages(excluding fruit/vegetable drink) 15. Soy milks 16. Fermented beverages 17. Ginseng/red ginseng beverages 18. Soy sauces and pastes 19. Vinegars 20. Tomato ketchup 21. Curries 22. Hot pepper powder, shredded hot pepper 23. Natural spice 24. Composite seasoning 25. Mayonnaise 26. <i>Kimchi</i> products 	<p>Colour</p>
--------------------------------	--	---------------

27. Salted and fermented seafood products
28. Pickled food products(excluding Hermetic sealing, heat-pasteurization or sterilization pickled food products)
29. Pickled radish
30. Boiled foods
31. Processed peanut or nut products
32. Seasoned laver
33. Honeys
34. Ready-to-cook food
35. Retort foods
36. Foods for special dietary uses
37. Health functional food(excluding tablet's coating or capsule)

Food additive	Use Level	Major functional class
dl-α-Tocopherol Acetate	It should be used in accordance with Section II.2.1).	Fortifying nutrient Antioxidant
d-α-Tocopherol Concentrate	It should be used in accordance with Section II.2.1).	Fortifying nutrient Antioxidant
d-Tocopherol Concentrate, Mixed	It should be used in accordance with Section II.2.1).	Fortifying nutrient Antioxidant
d-α-Tocopheryl Acetate	It should be used in accordance with Section II.2.1).	Fortifying nutrient Antioxidant
d-α-Tocopheryl Acid Succinate	It should be used in accordance with Section II.2.1).	Fortifying nutrient Antioxidant
Tomato Color	Tomato Color should not be used in the food items listed below. <ol style="list-style-type: none"> 1. Natural food[meat, fishes and shellfishes, fruits, vegetables, algae, Legume vegetables and pulses, and their simply processed food(peeled, cut, and etc.)] 2. Teas 3. Coffee 4. Hot pepper powder, shredded hot pepper 5. <i>Kimchi</i> products 6. <i>Gochujang</i>(hot pepper soy paste), seasoned hot pepper soy paste 7. Vinegars 	Colour
Tragacanth Gum	It should be used in accordance with Section II.2.1).	Thickener Stabilizer
Transglucosidase	It should be used in accordance with Section II.2.1).	Enzyme preparations

Food additive	Use Level	Major functional class
Transglutaminase	It should be used in accordance with Section II.2.1).	Enzyme preparations
Triacetin	It should be used in accordance with Section II.2.1).	Emulsifier Gum base
Trisodium Citrate	It should be used in accordance with Section II.2.1).	Acidity regulator Fortifying nutrient
Trypsin	It should be used in accordance with Section II.2.1).	Enzyme preparations
DL-Tryptophan	It should be used in accordance with Section II.2.1).	Fortifying nutrient
L-Tryptophan	It should be used in accordance with Section II.2.1).	Fortifying nutrient
L-Tyrosine	It should be used in accordance with Section II.2.1).	Fortifying nutrient
γ-Undecalactone	r-Undecalactone should be used for flavorings only.	Flavouring agent
Urease	It should be used in accordance with Section II.2.1).	Enzyme preparations
L-Valine	It should be used in accordance with Section II.2.1).	Fortifying nutrient
Vanillin	Vanillin should be used for flavorings only.	Flavouring agent
Vitamin A in oil	It should be used in accordance with Section II.2.1).	Fortifying nutrient
Vitamin B12	It should be used in accordance with Section II.2.1).	Fortifying nutrient
Vitamin B1 Dilaurylsulfate	It should be used in accordance with Section II.2.1).	Fortifying nutrient

Food additive	Use Level	Major functional class
Vitamin B1 Hydrochloride	It should be used in accordance with Section II.2.1).	Fortifying nutrient
Vitamin B1 Mononitrate	It should be used in accordance with Section II.2.1).	Fortifying nutrient
Vitamin B1 Naphthalene-1.5-disulfonate	It should be used in accordance with Section II.2.1).	Fortifying nutrient
Vitamin B1 Rhodanate	It should be used in accordance with Section II.2.1).	Fortifying nutrient
Vitamin B2	It should be used in accordance with Section II.2.1).	Fortifying nutrient
Vitamin B2 Phosphate Sodium	It should be used in accordance with Section II.2.1).	Fortifying nutrient
Vitamin B6 Hydrochloride	It should be used in accordance with Section II.2.1).	Fortifying nutrient
Vitamin C	It should be used in accordance with Section II.2.1).	Antioxidant Fortifying nutrient
Vitamin D2	It should be used in accordance with Section II.2.1).	Fortifying nutrient
Vitamin D3	It should be used in accordance with Section II.2.1).	Fortifying nutrient
Vitamin E	It should be used in accordance with Section II.2.1).	Fortifying nutrient
Vitamin K1	Vitamin K1 should be used only for the following food items. The usage should be 1. Milk formulas, Infant formulas, follow-up formulas, cereal formulas for infants/young children, other foods for infant/young children 2. Food for special medical purposes 3. Health functional food	Fortifying nutrient

Food additive	Use Level	Major functional class
Xanthan Gum	It should be used in accordance with Section II.2.1).	Thickener Stabilizer
Xylanase	It should be used in accordance with Section II.2.1).	Enzyme preparations
Xylitol	It should be used in accordance with Section II.2.1).	Sweetener Humectant
D-Xylose	It should be used in accordance with Section II.2.1).	Sweetener
Yeast	It should be used in accordance with Section II.2.1).	Raising agent
Yeast Extract	It should be used in accordance with Section II.2.1).	Flavour enhancer
Yucca Extract	It should be used in accordance with Section II.2.1).	Emulsifier
Zinc Gluconate	Zinc Gluconate should be used only for the following food items. 1. Beverages(excluding Teas and Coffee) 2. Cereals 3. Milk formulas, Infant formulas, follow-up formulas, cereal formulas for infants/young children, other foods for infant/young children 4. Food for special medicinal purposes 5. Weight control formulas 6. Health functional food	Fortifying nutrient
Zinc Oxide	It should be used in accordance with Section II.2.1).	Fortifying nutrient

Food additive	Use Level	Major functional class
Zinc Sulfate	<p>Zinc Sulfate should be used only for the following food items.</p> <ol style="list-style-type: none"> 1. Cereals, beer, other alcoholic beverages 2. Milk formulas, Infant formulas, follow-up formulas, cereal formulas for infants/young children, other foods for infant/young children 3. Food for special medical purposes 4. Weight control formulas 5. Health functional food 	Fortifying nutrient manufacturing solvent
Natural Flavoring Substances	Natural flavoring substances should be used for flavorings only.	Flavouring agent
Synthetic Flavoring Substances	Synthetic flavoring should be used for flavorings only.	Flavouring agent
Boiler Water Additives	<p><MFDS regulation 2017-100, 2017.12.11.> <u>[Enforcement date: 2019.1.1.]</u> It should be used only to clean the boiler which is used for manufacturing food or processing steam.</p>	Boiler Water Additives

B. Mixed Preparations

Unless otherwise specified, when there is use level on ingredients of mix preparations it should be properly used by its use level(it corresponds to use level of appropriate additives)

C. Milk formulas, Infant formulas, Follow-up formulas, Cereal formulas for infants/young children, Other foods for infants/young children, Formulas for infants/young children with milk protein allergy, and Special formulas for infants/young children

Whereas specified food categories are not mentioned on the use level table of section II.5. for each food additive, Milk formulas, Infant formulas, Follow-up formulas, Cereal formulas for infants/young children, Other foods for infants/young children, Formulas for infants/young children with milk protein allergy, and Special formulas for infants/young children (hereinafter referred to as "milk formulas etc.") should only be used for the following food additives.

- (1) Food additives, which are used to nutrients supplement in Milk formula etc. refer to the followings. However, Sodium Selenite and Sodium Selenate should only be used for Milk formulas, Infant formulas, Follow-up formulas, Formulas for infants/young children with milk protein allergy, and Special formulas for infants/young children. Sodium Molybdate, Ammonium Molybdate and Chromic Chloride should only be used for Formulas for infants/young children with milk protein allergy and Special formulas for infants/young children.

Nutrient	List of Food Additives
Calcium (Ca)	Calcium Citrate
	Calcium Gluconate
	Calcium Glycerophosphate
	Calcium Oxide
	Calcium Chloride
	Calcium Lactate
	Calcium Phosphate, Tribasic*
	Calcium Phosphate, Dibasic*
	Calcium Phosphate, Monobasic*
	Calcium Carbonate
	Calcium Sulfate

Nutrient	List of Food Additives
Iron (Fe)	Ferric Citrate
	Ferric Ammonium Citrate
	Ferrous Gluconate
	Ferric Phosphate*
	Iron, Electrolytic
	Ferrous Lactate
	Ferrous Fumarate
	Ferric Pyrophosphate*
	Sodium Ferric Pyrophosphate*
	Iron, Reduced
Ferrous Sulfate	
Magnesium (Mg)	Magnesium Oxide
	Magnesium Hydroxide
	Magnesium Chloride
	Magnesium Phosphate, Tribasic*
	Magnesium Phosphate, Dibasic*
	Magnesium Carbonate
	Magnesium Sulfate
Sodium (Na)	Trisodium Citrate
	Sodium Gluconate
	Sodium Lactate
	Sodium Phosphate, Tribasic*
	Sodium Phosphate, Dibasic*
	Sodium Phosphate, Monobasic*
	Sodium L-Tartrate

Nutrient	List of Food Additives
	Sodium Carbonate
	Sodium Bicarbonate
	Sodium Sulfate
Potassium (K)	Potassium Citrate
	Potassium Gluconate
	Potassium Glycerophosphate*
	Potassium Chloride
	Potassium Phosphate, Dibasic*
	Potassium Phosphate, Monobasic*
	Potassium Bicarbonate
Copper (Cu)	Copper Gluconate
	Cupric Sulfate
Iodine (I)	Potassium Iodide
	Potassium Iodate
Zinc (Zn)	Zinc Gluconate
	Zinc Oxide
	Zinc Sulfate
Manganese (Mn)	Manganese Citrate
	Manganese Gluconate
	Manganese Chloride
	Manganese Sulfate
Selenium (Se)	Sodium Selenate
	Sodium Selenite
Chrome (Cr)	Chromic Chloride
Molybdenum	Sodium Molybdate

Nutrient	List of Food Additives
(Mb)	Ammonium Molybdate
Vitamin A	Dry Formed Vitamin A
	Vitamin A in Oil
	β -Carotene
Vitamin D	Calciferol
	Cholecalciferol
Vitamin E	<i>d</i> - α -Tocopherol
	<i>d</i> - α -Tocopheryl Acetate
	<i>d</i> - α -Tocopheryl Acetate
Vitamin C	L-Ascorbic Acid
	Sodium L-Ascorbate
	Calcium L-Ascorbate
	L-Ascorbyl Palmitate
Vitamin B ₁	Thiamine Hydrochloride
	Thiamine Mononitrate
Vitamin B ₂	Riboflavin
	Riboflavin 5'-Phosphate Sodium
Niacin	Nicotinic Acid
	Nicotinamide
Vitamin B ₆	Pyridoxine Hydrochloride
Folic acid	Folic Acid
Pantothenic acid	Calcium Pantothenate
Vitamin B ₁₂	Cyanocobalamin
Vitamin K ₁	Phylloquinone
Biotin	Biotin

Nutrient	List of Food Additives
Amino acid	L-Leucine
	L-Methionine
	L-Valine
	L-Cystine
	L-Arginine
	L-Isoleucine
	L-Threonine
	L-Tryptophan
	L-Tyrosine
	L-Phenylalanine
	L-Histidine
Nucleotide	Disodium 5'-Guanylate
	Disodium 5'-Ribonucleotide
	Calcium 5'-Ribonucleotide
	5'-Cytidylic Acid
	Disodium 5'-Cytidylate
	5'-Adenylic Acid
	Disodium 5'-Uridylate
	Disodium 5'-Inosinate
Others	Choline Chloride
	Inositol
	Phosphoric Acid*
	Choline Bitartrate
	L-Carnitine
	Taurine

* It can also be used as a material food additive of Nutrient Phosphorus(P)

(2) Food additives, which are used to others except nutrients supplement in Milk formula etc. refer to the followings.

List of Food Additives
Guar Gum
Citric Acid
Trisodium Citrate
Potassium Citrate
Glucoamylase
Glycerin Esters of Fatty Acids
Lactoferrin Concentrates
Lecithin
Locust Bean Gum
Lysozyme
Maltogenic Amylase
Mucin
Vanilla extract
Vanillin
Food Starch Modified
Potassium Hydroxide
Calcium Hydroxide
Arabic Gum
α -Amylase, Nonbacterial(DU)
α -Amylase, Bacterial(BAU)
Calcium L-Ascorbate
L-Ascorbyl Palmitate
Ethyl Vanillin

List of Food Additives
Magnesium Chloride
Lactic Acid
Potassium Phosphate, Dibasic
Gelatin
Carrageenan
Casein
Sodium Caseinate
Sodium Carbonate
Sodium Bicarbonate
Potassium Bicarbonate
Potassium Carbonate, Anhydrous
α -Tocopherol concentrate, Mixed
Pectin
Plant Protease(PU)
Heme Iron

<MFDS's Regulation #2018-84, 2018.11.1.> [Date of entry into force 2019.7.1.]

(2) Followings are food additives that are allowed to use in Milk formulas, etc. for purposes other than nutrient fortifying, and use levels are as shown.

Food Additives	Use Level (When it comes to products that are eaten after dilution, it is applied as diluted products.)
Guar Gum	No more than 2 g/kg (But no more than 10 g/kg for Cereal Formulas for Infants/Young Children)
Citric Acid	It should be used as in accordance with

Trisodium Citrate	Section II.2.1). It should be used as in accordance with Section II.2.1).
Potassium Citrate	It should be used as in accordance with Section II.2.1).
Glucoamylase	It should be used as in accordance with Section II.2.1).
Glycerin Esters of Fatty Acids	No more than 9 g/kg
Lactoferrin Concentrates	It should be used as in accordance with Section II.2.1).
Lecithin	No more than 5 g/kg (But no more than 15 g/kg for Cereal Formulas for Infants/Young Children)
Locust Bean Gum	No more than 2 g/kg (But no more than 10 g/kg for Cereal Formulas for Infants/Young Children)
Lysozyme	It should be used as in accordance with Section II.2.1).
Maltogenic Amylase	It should be used as in accordance with Section II.2.1).
Mucin	It should be used as in accordance with Section II.2.1).
Vanilla extract (Natural Flavoring Substances)	It should be used as in accordance with Section II.2.1).
Vanillin	No more than 0.05 g/kg (But no more than 0.07 g/kg for Other Foods for Infants/Young Children)
Food Starch Modified	No more than 5 g/kg (But no more than 60 g/kg for Cereal Formulas for Infants/Young Children, Formulas for Infants/Young Children with milk protein allergy, and Other Foods for

<p>Potassium Hydroxide</p> <p>Calcium Hydroxide</p>	<p>Infants/Young Children)</p> <p>It should be used as in accordance with Section II.2.1).</p> <p>It should be used as in accordance with Section II.2.1).</p>
<p>Arabic Gum</p> <p>α-Amylase, Nonbacterial</p>	<p>No more than 2 g/kg (But no more than 10 g/kg for Cereal Formulas for Infants/Young Children)</p> <p>It should be used as in accordance with Section II.2.1).</p>
<p>α-Amylase, Bacterial</p> <p>Calcium L-Ascorbate</p> <p>L-Ascorbyl Palmitate</p> <p>Ethyl Vanillin</p> <p>Magnesium Chloride</p> <p>Lactic Acid</p>	<p>It should be used as in accordance with Section II.2.1).</p> <p>No more than 0.2 g/kg</p> <p>No more than 0.05 g/kg (But no more than 0.2 g/kg for Cereal Formulas for Infants/Young Children and Other Foods for Infants/Young Children)</p> <p>No more than 0.05g/kg (But no more than 0.07 g/kg for Other Foods for Infants/Young Children)</p> <p>It should be used as in accordance with Section II.2.1).</p> <p>No more than 2 g/kg</p>
<p>Potassium Phosphate, Dibasic</p> <p>Gelatin</p> <p>Carrageenan</p>	<p>It should be used as in accordance with Section II.2.1).</p> <p>It should be used as in accordance with Section II.2.1).</p> <p>No more than 1 g/kg</p>

Casein	It should be used as in accordance with Section II.2.1).
Sodium Caseinate	It should be used as in accordance with Section II.2.1).
Sodium Carbonate	It should be used as in accordance with Section II.2.1).
Sodium Bicarbonate	It should be used as in accordance with Section II.2.1).
Potassium Bicarbonate	It should be used as in accordance with Section II.2.1).
Potassium Carbonate, Anhydrous	It should be used as in accordance with Section II.2.1).
d-Tocopherol concentrate, Mixed	No more than 0.03 g/kg
Pectin	No more than 10 g/kg
Plant Protease	It should be used as in accordance with Section II.2.1).
Heme Iron	It should be used as in accordance with Section II.2.1).

III. Standards and Specification for Food Contact Surface Sanitizing Solutions

1. Standards for Manufacturing and Preparation

1) General active and inert ingredient for use in food-contact surface sanitizing solutions

The active and inert ingredients for use in food-contact surface sanitizing solutions are as follows. However, food additive(excluding product that should be removed or neutralized before the final food product is completed) or food raw materials authorized for use in Republic of Korea can be used.

No.	Ingredients	CAS No.
1	Hydrogen peroxide	7722-84-1
2	Peroxyoctanoic acid	33734-57-5
3	Peroxyacetic acid	79-21-0
4	Citric acid	77-92-9
5	D-Gluconic acid, monosodium salt	527-07-1
6	Neodecanoic acid	26896-20-8
7	Nonanoic acid	112-05-0
8	Decanoic acid	334-48-5
9	Benzenesulfonic acid, dodecyl-	27176-87-0
10	Benzenesulfonic acid, dodecyl-, sodium salt	25155-30-0
11	Sodium dimethylbenzene sulfonate(Xylenesulfonic acid, sodium salt)	1300-72-7
12	1-Octanamine, N,N-dimethyl-	7378-99-6
13	Phenol, 4-(1,1-dimethyl-propyl)-	80-46-6
14	Dioctyl sodium sulfosuccinate	577-11-7
15	Methylene blue	61-73-4
16	2,4-Pentanediol, 2-methyl-	107-41-5
17	Sulfuric acid monododecyl ester, sodium salt	151-21-3

No.	Ingredients	CAS No.
	(sodium lauryl sulfate)	
18	Ethanol, 2-butoxy-	111-76-2
19	Boric acid, sodium salt	7775-19-1
20	Potassium bromide	7758-02-3
21	Magnesium oxide	1309-48-4
22	Trichloroisocyanuric acid (1,3,5-Triazine-2,4,6(1H,3H,5H)-trione,1,3,5-trichloro)	87-90-1
23	Sodium trichloroisocyanurate	29680-41-9
24	Potassium trichloroisocyanurate	-
25	Butanedioic acid, sulfo-, 1,4-dioctyl ester, sodium salt	1639-66-3
26	9-Octadecenoic acid(9Z)-, sulfonated	68988-76-1
27	9-Octadecenoic acid(9Z)-, sulfonated, sodium salts	68443-05-0
28	Fatty acids, tall-oil, sulfonated, sodium salts	68309-27-3
29	1-Octanesulfonic acid, 2-sulfino-	113652-56-5
30	Ethanesulfonic acid, 2- [cyclohexyl(1-oxohexadecyl) amino]-, sodium salt	132-43-4
31	Chlorite	14998-27-7
32*	α -alkyl- ω -hydroxypoly (oxypropylene) and/or poly (oxyethylene) polymers where the alkyl chain contains a minimum of six carbons	-
33	Sodium- α -alkyl(C ₁₂ -C ₁₅)- ω -hydroxypoly(oxyethylene) sulfate with the poly (oxyethylene) content averaging one mole	-
34	Ethanol	64-17-5
35	Ethanol, 2-(2-ethoxyethoxy)-	111-90-0

No.	Ingredients	CAS No.
36	Ethylenediaminetetraacetic acid(EDTA), tetrasodium salt	64-02-08
37	Ethylenediaminetetraacetic acid(EDTA), disodium salt	139-33-3
38	Chlorate	14866-68-3
39	N-Decyl-N,N-dimethyl-1-decanaminium chloride	7173-51-5
40	Di-n-alkyl(C ₈ -C ₁₀) dimethyl ammonium chloride, average molecular weight (in amu), 332 to 361	-
41	Chloromelamine(1,3,5-Triazine, N,N',N"-trichloro -2,4,6-triamino-)	7673-09-8
42	n-Alkyl(C ₁₂ -C ₁₄) dimethyl ethylbenzyl ammonium chloride, average molecular weight(in amu), 377 to 384	-
43	n-Alkyl (C ₁₂ -C ₁₈) dimethyl ethylbenzyl ammonium chloride, average molecular weight(in amu), 384	-
44	Alkyl(C ₁₂ -C ₁₈) benzyldimethyl chlorides	-
45	Ammonium chloride	12125-02-9
46*	Oxirane, methyl-, polymer with oxirane, minimum molecular weight (in amu), 1,900	9003-11-6
47	Oxirane, methyl-, polymer with oxirane, block, average molecular weight (in amu), 1,900	106392-12-5
48	Oxirane, methyl-, polymer with oxirane, block, minimum average molecular weight (in amu), 2,000	-
49	Oxirane, methyl-, polymer with oxirane, block, 27 to 31 moles of polyoxypropylene, average molecular weight (in amu), 2,000	-
50	Oxychloro species	-
51	Octadecanoic acid, calcium salt(Calcium stearate)	1592-23-0
52	1,2-Octanedisulfonic acid	113669-58-2

No.	Ingredients	CAS No.
53	Octanoic acid	124-07-2
54	1-Octanesulfonic acid	3944-72-7
55	1-Octanesulfonic acid, sodium salt	5324-84-5
56	Butanedioic acid, octenyl-	28805-58-5
57	Iodine	7553-56-2
58	Sodium iodide	7681-82-5
59	Potassium iodide	7681-11-0
60	Hydriodic acid	10034-85-2
61	Chlorine dioxide	10049-04-4
62	Dichloroisocyanuric acid (1,3,5-Triazine-2,4,6(1H,3H,5H)-trione, 1,3-dichloro-)	2782-57-2
63	Sodium dichloroisocyanurate (1,3,5-Triazine-2,4,6(1H,3H,5H)-trione, 1,3-dichloro-, sodium salt)	2893-78-9
64	Sodium dichloroisocyanurate dihydrate(1,3,5-Triazine- 2,4,6(1H,3H,5H)-trione, 1,3-dichloro-, sodium salt)	51580-86-0
65	Dichloroisocyanuric acid, potassium salt (1,3,5-Triazine-2,4,6(1H,3H,5H)-trione,1,3-dichloro-, potassium salt)	2244-21-5
66	Phosphoric acid	7664-38-2
67	Phosphoric acid, monosodium salt	7558-80-7
68	Phosphoric acid, trisodium salt	7601-54-9
69	Iodine monochloride	7790-99-0
70	Silver ions resulting from the use of electrolytically - generated silver ions stabilized in citric acid as silver dihydrogen citrate (does not include metallic silver)	14701-21-4
71	Lactic acid	50-21-5

No.	Ingredients	CAS No.
72*	Nitric acid	7697-37-2
73	Hypochlorous acid	7790-92-3
74	Sodium hypochlorite	7681-52-9
75	Lithium hypochlorite	13840-33-0
76	Potassium hypochlorite	7778-66-7
77	Calcium hypochlorite	7778-54-3
78	Acetic acid	64-19-7
79	n-Carboxylic acids(C ₆ -C ₁₂)[consisting of a mixture of not less than 56% octanoic acid and not less than 40% decanoic acid]	-
80	Fatty acids, coco, potassium salts	61789-30-8
81	Acetic acid, chloro-, sodium salt, reaction products with 4,5-dihydro-2-undecyl-1H-imidazole-1-ethanol and sodium hydroxide	68608-66-2
82	Phenol, 4-chloro-2-(phenylmethyl)-	120-32-1
83	3-Cyclohexene-1-methanol, $\alpha,\alpha,4$ -trimethyl-	98-55-5
84	Phenylphenol ([1,1'-Biphenyl]-2-ol)	90-43-7
85*	Butoxy monoether of mixed(ethylene-propylene) polyalkylene glycol, minimum average molecular weight (in amu), 2,400	-
86	Butoxy monoether of mixed(ethylene-propylene)poly alkylene glycol, cloud point of 90-100° in 0.5 aqueous solution, average molecular weight (in amu), 3,300	-
87*	Poly(oxy-1,2-ethanediyl), α -[(1,1,3,3-tetramethylbutyl) phenyl]- ω -hydroxy-, produced with one mole of the phenol and 4 to 14 moles ethylene oxide	-

No.	Ingredients	CAS No.
88	Polyoxyethylene polyoxypropylene block polymer(MW 2,800)	-
89	Poly(hexamethylene biguanide)hydrochloride	32289-58-0
90	2-Propanol(isopropanol)	67-63-0
91	Propionic acid	79-09-4
92	2,6-Pyridine dicarboxylic acid	499-83-2
93	Phosphonic acid, (1-hydroxyethylidene)bis-	2809-21-4
94	Sulfuric acid	7664-93-9
The ingredient marked with "*" should not use as active ingredient in food-contact surface sanitizing solutions.		

2) General food-contact surface sanitizing solutions

- (1) Food-contact surface sanitizing solutions should contain active ingredient on sterilizing and antimicrobial effect for harmful microorganisms.
- (2) Food-contact surface sanitizing solutions should conform to the standards and specifications of individual specifications.
- (3) Water for manufacturing Food-contact surface sanitizing solutions should be appropriate to the water quality standard of the drinking water according to 「Drinking Water Management Act」.

2. General Use Level on Food-Contact Surface Sanitizing Solutions

Food-contact surface sanitizing solutions should be used appropriately within the individual use level for the purpose of sterilizing and antimicrobial effect, and it should be removed in appropriate ways, such as natural-air drying, hot-air drying, before contacting with food.

3. Preservation and Distribution Standards

- 1) The storage and sale place of products shall be kept clean and well ventilated.
- 2) The product shall be sealed and stored in a cool, dry place where direct sunlight and heat are avoided to prevent deterioration.
- 3) Products shall be stored separately to prevent contamination of food and food additives, etc.
- 4) Products shall not be stored with other products such as chemicals, agricultural chemicals, and toxic substances, etc.
- 5) Containers and packaging shall not be damaged during the transportation and packaging process of the product, and care should be taken not to cause as much impact as possible.
- 6) Products that are discolored or damaged due to carelessness during storage shall not be sold.

4. Standards and Specification

Ethanol Preparations

Definition Ethanol preparations contains Ethanol as an active ingredient. However, Diluent, stabilizers, dissolving agents, etc. can be added for dilution or stability in quality.

Compositional Specifications of Ethanol preparations

Description Ethanol preparations is colorless~pale yellow liquid with characteristic odor.

Identification Pipet about 0.6 g of ethanol preparations and add acetone to bring the volume to 25 mL, test solution. Shake the sample until it is completely dispersed, if necessary, centrifuge it and use the supernatant. Separately, add acetone to 0.6 g of ethanol standard material to make 25 mL, standard solution. Gas chromatography is carried out with both solutions under the following operation conditions. Retention time of the main peak of Test Solution should be identical to that of Standard Solution.

Operation Condition

Column : DB WAX(30m×0.53mm ID, coating thickness 1.0 μ m)or its equivalent

Detector : Hydrogen Flame Ionization Detector (FID)

Column Temperature : 60 ~ 150°C

Temperature at injection port : 150 ~ 200°C

Detector Temperature: 150 ~ 200°C

Carrier gas and Flow rate : N₂ or He, flow rate 1mL/min

Test of Bactericidal Activity When ethanol preparations is tested by Test Method of Bacterial Suspension or Test Method of Bacterial Surface in Test of Bactericidal Activity, it should be appropriate.

N-Decyl-N,N-dimethyl-1-1-decanaminium Chloride Preparations

Definition It contains N-decyl-N,N-dimethyl-1-1-decanaminium Chloride as an active ingredient. However, Diluent, stabilizers, dissolving agents, etc. can be added for dilution or stability in quality.

Compositional Specifications of N-decyl-N,N-dimethyl-1-1-decanaminium Chloride preparations

Description N-decyl-N,N-dimethyl-1-1-decanaminium Chloride preparations is liquid with characteristic odor.

Identification (1) N-decyl-N,N-dimethyl-1-1-decanaminium Chloride preparations responds to the tests for Ammonium Salt and Chlorides.

(2) Pipet 1 g of N-decyl-N,N-dimethyl-1-1-decanaminium Chloride preparations and dilute to volume of 100 mL with water, test solution. Separately, when adding 5 mL of test solution to the mixture of 2~3 drops of brom phenol blue.sodium hydroxide solution, 5 mL of 0.1N sodium hydroxide solution, and 5 mL of chloroform, the chloroform layer of the solution appears blue.

Test of Bactericidal Activity When N-decyl-N,N-dimethyl-1-1-decanaminium Chloride preparations is tested by Test Method of Bacterial Suspension in Test of Bactericidal Activity, it should be appropriate.

n-Alkyl(C₁₂-C₁₈)benzyltrimethylammonium Chloride Preparations

Definition n-alkyl(C₁₂-C₁₈)benzyltrimethylammonium Chloride Preparations contains Quaternary ammonium compounds, n-alkyl(C₁₂-C₁₄)benzyl-dimethyl chlorides or 1 or more of Quaternary ammonium compounds, n-alkyl(C₁₂-C₁₈) dimethyl ethylbenzyl ammonium chloride (average molecular weight 377~384), n-alkyl(C₁₂-C₁₈) dimethyl ethylbenzyl ammonium chloride (average molecular weight 384), Quaternary ammonium compounds, di-n-alkyl(C₈-C₁₀) dimethyl ammonium chloride (average molecular weight 332 to 361), or Poly (hexamethylene biguanide) hydrochloride contained to Quaternary ammonium compounds, alkyl(C₁₂-C₁₄) benzyl-dimethyl chlorides as an active ingredient. However, Diluent, stabilizers, dissolving agents, etc. can be added for dilution or stability in quality.

Compositional Specifications of n-Alkyl(C₁₂-C₁₈)benzyltrimethylammonium Chloride

Description n-alkyl(C₁₂-C₁₈)benzyltrimethylammonium Chloride Preparations is liquid with characteristic odor.

Identification (1) n-alkyl(C₁₂-C₁₈)benzyltrimethylammonium Chloride Preparations responds to the tests for Ammonium Salt and Chlorides.

(2) Pipet 1 g of n-alkyl(C₁₂-C₁₈)benzyltrimethylammonium Chloride Preparations and dilute to 100 mL with water, test solution. Separately, when adding 5 mL of test solution to the mixture of 2~3 drops of Brom phenol blue . Sodium hydroxide solution, 5 mL of 0.1N sodium hydroxide solution, and 5 mL of chloroform, the chloroform layer of the solution becomes blue.

Test of Bactericidal Activity When n-alkyl(C₁₂-C₁₈)benzyltrimethylammonium Chloride Preparations is tested by Test Method of Bacterial Suspension in Test of Bactericidal Activity, it should be appropriate.

Sodium Dichloroisocyanurate Preparations

Definition Sodium Dichloroisocyanurate preparations contains Sodium Dichloroisocyanurate and Sodium Dichloroisocyanurate 2 hydrate as active ingredients. However, Diluent, stabilizers, dissolving agents, etc. can be added for dilution or stability in quality.

Compositional Specifications of Sodium Dichloroisocyanurate preparations

Description Sodium Dichloroisocyanurate preparations is white crystallite, white granular powder or tablet with odor of chlorine.

Identification (1) When diluted hydrochloric acid is added to Sodium Dichloroisocyanurate preparations, gas with odor of chlorine is generated.

(2) Gas in (1) make the colour of potassium iodide starch paper (wetted with water) blue.

(3) Sodium Dichloroisocyanurate preparations responds to the tests for (1) Sodium Salt in Identification.

Purity (1) Iron : 1 g of Sodium Dichloroisocyanurate preparations, ignited by the procedure in Residues on Ignition, and then the residue is generated. To the residue, add 2 mL of diluted hydrochloric acid(1→2), dissolve, and evaporate to dryness it in a water bath. Dissolve it in 1 mL of hydrochloric acid and dilute to 50 mL with water. Pipet 10 mL of this solution, dilute to 40 mL with water, add 40 mg of ammonium persulfate and 10 mL of ammonium thiocyanate solution., then red or pink color develops. That color should not be deeper than the color appeared when 3 mL of iron standard solution is taken instead of test solution and proceeded in the same manner as test solution. (not more than 150 ppm).

(2) Lead : When 2.0 g of Sodium Dichloroisocyanurate Preparations is tested by Atomic Absorption Spectrophotometry or Inductively Coupled Plasma Emission Spectroscopy, its content should not be more than 10 ppm.

Test of Bactericidal Activity When Sodium Dichloroisocyanurate preparations is tested by Test Method of Bacterial Suspension in Test of Bactericidal Activity, it should be appropriate.

Sodium Hypochlorite Preparations

Definition This item contains Sodium Hypochlorite preparations as active ingredient and includes acquiring saline solution by electrolysis. However, Diluent, stabilizers, etc. can be added for dilution or stability in quality.

Compositional Specifications of Sodium Hypochlorite preparations

Description Sodium Hypochlorite preparations is colorless to light green-yellow liquid or powder having an odor of chlorine.

Identification (1) Sodium Hypochlorite preparations is diluted with water so that 50 ~ 100 μ g of active chlorine is contained per mL of Sodium Hypochlorite preparations, test solution. Separately, pipet 0.5 mL of sodium stock standard solution and dilute to 100 mL with water, sodium standard solution. When Sodium standard solution and test solution are tested by Atomic Absorption Spectrophotometry, the peak of sodium should be identified.

(2) To 5 mL of test solution in (1), add 1 mL of sodium hydroxide solution(1 \rightarrow 2,500) and 0.2 mL of potassium iodine solution, the color of the solution turns yellow. Again add 0.5 mL of starch solution, then the solution becomes deep blue.

(3) To 5 mL of test solution in (1), add 0.1 mL of potassium permanganate solution(1 \rightarrow 300) and add 1 mL of sulfuric acid(1 \rightarrow 20) to this solution, then the red violet of solution doesn't fade.

(4) To 90 mL of test solution in (1), add 100 mL of sodium hydroxide (1 \rightarrow 5), then the solution shows maximum absorption band at 290 ~ 294nm.

Test of Bactericidal Activity When Sodium Hypochlorite preparations is tested by Test Method of Bacterial Suspension in Test of Bactericidal Activity, it should be appropriate.

Hypochlorous Acid Water Preparations

Definition Hypochlorous Acid Water preparations is obtained by electrolysis of hydrochloric acid or saline solution. The aqueous solution contains Hypochlorous Acid as an active ingredient. This item includes strongly acidic hypochlorous acid water (aqueous solution obtained from both poles by electrolyzing sodium chloride (not more than 0.2%) in an electrolytic bath with septum composed of anode and cathode, which are separated by septum), moderately acidic hypochlorous acid water (aqueous solution obtained from both poles by electrolyzing an valid concentration of sodium chloride in an electrolytic bath with septum composed of anode and cathode, which are separated by septum or solution that collect under the anodes added solution that collect under the cathode) and slightly acidic hypochlorous acid water (aqueous solution, which is adjusted with valid concentration after adding sodium chloride to the hypochlorous acid water, in an aseptate electrolytic bath without septum) are included in this material.

Compositional Specifications of Hypochlorous Acid Water preparations

Description Hypochlorous Acid Water preparations is colorless, odorless or with slight odor of chlorine.

Identification (1) To 5 mL of Hypochlorous Acid Water preparations, add 1 mL of sodium hydroxide(1→2,500) and 0.2 mL of potassium iodide, then yellow color develops. When adding 0.5 mL of starch solution to this solution, deep blue color develops.

(2) To 5 mL of Hypochlorous Acid Water preparations, add 0.1 mL of potassium permanganate solution(1→300) and add 1 mL of sulfuric acid(1→20) to this solution, then red violet color doesn't fade.

(3) To 90 mL of Hypochlorous Acid Water, add 100 mL of sodium hydroxide(1→5), then the solution exhibits an absorption maximum at a wavelength of 290~294 nm.

Purity (1) pH : When pH is determined by glass electrode method, not more than 2.7 for strongly acidic Hypochlorous Acid Water, 2.7~5.0 for moderately acidic Hypochlorous Acid Water and 5.0~6.5 for slightly acidic Hypochlorous Acid Water.

(2) Evaporation Residue : When pipetting 20.0g of Hypochlorous Acid Water preparations and drying it for 2 hours at 110°C after evaporating water, the residue should not be more than 0.25%.

Test of Bactericidal Activity When Hypochlorous Acid Water preparations is tested by Test Method of Bacterial Suspension in Test of Bactericidal Activity, it should be appropriate.

Poly(hexamethylenebiguanide)hydrochloride Preparations

Definition Poly (hexamethylenebiguanide) hydrochloride preparations contains Poly (hexamethylenebiguanide) hydrochloride or Quaternary ammonium compounds, Poly (hexamethylenebiguanide) hydrochloride containing di-n-alkyl(C₈-C₁₀) dimethyl ammonium chloride (average molecular weight 332 to 361) as active ingredient . However, Diluent, stabilizers, dissolving agents, etc. can be added for dilution or stability in quality.

Compositional Specifications of Poly(hexamethylenebiguanide)hydrochloride preparations

Description Poly(hexamethylenebiguanide)hydrochloride preparations is liquid with characteristic odor.

Identification (1) Poly(hexamethylenebiguanide)hydrochloride preparations responds to the tests for Ammonium Salt and Chlorides.

(2) Pipet 1 g of Poly(hexamethylenebiguanide)hydrochloride preparations and dilute to 100 mL with water, test solution. Separately, add 5 mL of test solution to the mixture of 2~3 drops of Brom phenol blue . Sodium hydroxide solution, 5 mL of 0.1N sodium hydroxide solution, and 5 mL of chloroform, then the chloroform layer of the solution becomes blue.

Test of Bactericidal Activity When Poly(hexamethylenebiguanide)hydrochloride preparations is tested by Test Method of Bacterial Suspension in Test of Bactericidal Activity, it should be appropriate.

Hydrogen Peroxide Preparations

Definition It contains Hydrogen Peroxide preparations as active ingredient. However, Diluent, stabilizers, dissolving agents, etc. can be added for dilution or stability in quality.

Compositional Specifications of Hydrogen Peroxide preparations

Description Hydrogen Peroxide preparations is a colorless, clear liquid. It has a slight odor.

Identification (1) When adding 5 mL of dilute sulfuric acid and 1 mL of potassium permanganate solution to an aqueous solution of Hydrogen Peroxide (1→10), bubbles are formed and the color of the solution disappears.

(2) Hydrogen Peroxide preparations shows the peroxide reaction in Identification.

Purity (1) Free acid : Add freshly boiled and cooled water to 3 mL of Hydrogen Peroxide preparations and make to 50 mL. When adding 1 mL of 0.02 N sodium hydroxide solution and 3 drops of phenolphthalein solution, the solution should turn red.

(2) Arsenic : Mix 0.25 mL of Hydrogen Peroxide preparations with 10 mL of water. Add a small amount of this solution in small portions to a platinum crucible in a water bath to evaporate the liquid to dryness. Add a small amount of water to the residues and use the entire solution as a Test Solution. This Test Solution is tested for arsenic and its content should be appropriate (Not more than 4ppm).

(3) Lead : Add 10 mL of water to 5 g of Hydrogen Peroxide preparations. And add a small amount of this solution in small portions to a platinum crucible in a water bath to warming it until forming bubbles is ended. Add 0.5N of nitric acid to make to 25mL. This solution is used as a Test Solution. When test solution is tested by Atomic Absorption Spectrophotometry or Inductively Coupled Plasma Emission Spectroscopy, its content should not be more than 4.0 ppm.

(4) Tin : Add 10 mL of water to 5 g of Hydrogen Peroxide preparations. And add a small amount of this solution in small portions to a platinum crucible in a water bath to warming it until forming bubbles is ended. Add 1N of hydrochloric acid to make to 25mL. This solution is used as a Test Solution. When test solution is tested by Atomic Absorption Spectrophotometry or Inductively Coupled Plasma Emission Spectroscopy, its content should not be more than 10 ppm.

(5) Iron : Add 10 mL of water to 5 g of Hydrogen Peroxide preparations. And add a small amount of this solution in small portions to a platinum crucible in a water bath to warming it until forming bubbles is ended. Add 0.5N of nitric acid to make to 25mL. This solution is used as a Test Solution. When test solution is tested by Atomic Absorption Spectrophotometry or Inductively Coupled Plasma Emission Spectroscopy, its content should not be more than 0.5 ppm.

(6) Residue on evaporation : To 10 mL of Hydrogen Peroxide, add about 20 mL of water. Add this solution in small portions to a platinum crucible. Evaporate it to dryness by gently heating in a water bath and cool down. Dry the residues for 1 hour at 105°C and the amount should not be more than 3 mg.

(7) Phosphate Salt : To 8 mL of Hydrogen Peroxide, add 10 mL of water and 3 mL of hydrochloric acid.

Then evaporate it to dryness by gently heating in a water bath. Add about 30 mL of warm water to dissolve the residues, which is then cooled down. Dilute the solution to 50mL with water, Test Solution. Transfer 5 mL of Test Solution into a Nestler tube, where 4 mL of dilute sulfuric acid (1→6) and 1 mL of ammonium molybdate solution (1→20) are added. Then mix it well by shaking and allowed to stand for 3 minutes, where 1 mL of 1-amino-2-naphthol-4-sulfonate solution is added. Heat it for 30 minutes in a water bath at 60°C and cool down in running water. The resulting blue color should not be deeper than that of the solution prepared by the same procedure with 5 mL of phosphate salt standard solution.

Test of Bactericidal Activity When Hydrogen Peroxide preparations is tested by Test Method of Bacterial Suspension(Test Method of Spore Suspension when used for sterilization of food container and packaging) in Test of Bactericidal Activity, it should be appropriate.

Peroxyacetic Acid Preparations

Definition Peroxyacetic Acid preparations is obtained by reaction of hydrogen peroxide and acetic acid, containing peroxyacetic acid, hydrogen peroxide and acetic acid as active ingredient or it is obtained by reaction of hydrogen peroxide, acetic acid, and caprylic acid(synonym: octanoic acid) containing peroxyacetic acid, peroxyoctanoic acid, hydrogen peroxide, caprylic acid, and acetic acid as active ingredient. However, 1-hydroxytiliden-1,1-diphosphonic acid, Phosphoric acid, or Sodium 1-Octanesulfonate are able to be added for dilution or quality stability.

Compositional Specifications of Peroxyacetic Acid preparations

Description Peroxyacetic Acid preparations is a colorless, clear liquid. It has a characteristic pungent odor.

Purity (1) Arsenic : Pipet 0.25 mL of Peroxyacetic Acid preparations and mix it with 10 mL of water. Add a small amount of this solution in small portions to a platinum crucible in a water bath to evaporate the liquid to dryness. Add a small amount of water to the residues and use the entire solution as Test Solution. This Test Solution is tested for arsenic and its content should be appropriate (Not more than 4ppm).

(2) Lead : Add 10 mL of water to 5 g of Peroxyacetic Acid preparations. And add a small amount of this solution in small portions to a platinum crucible in a water bath to warming it until forming bubbles is ended. Add 0.5N of nitric acid to make to 25mL. This solution is used as a Test Solution. When test solution is tested by Atomic Absorption Spectrophotometry or Inductively Coupled Plasma Emission Spectroscopy, its content should not be more than 4.0 ppm.

Test of Bactericidal Activity When Peroxyacetic Acid preparations is tested by Test Method of Bacterial Suspension(Test Method of Spore Suspension when used for sterilization of food container and packaging) in Test of Bactericidal Activity, it should be appropriate.

Citric Acid Preparations

Definition Citric Acid preparations contains Citric Acid as an active ingredient. However, Diluent, stabilizers, dissolving agents, etc. can be added for dilution or stability in quality.

Compositional Specifications of Citric Acid preparations

Description Citric Acid preparations occurs as transparent liquid having a characteristic odor.

Identification An aqueous solution of Citric Acid preparations (1→10) is acidic.

Purity (1) Sulfate : When 0.5 g of Citric Acid preparations is tested for Sulfates, its content should not be more than the amount that corresponds to 0.5 mL of 0.01 N sulfuric acid.

(2) Oxalate : When 1 g of Citric Acid preparations is dissolved in 10 mL of water, where 2 mL of calcium chloride solution is added, it should not be turn turbid.

(3) Arsenic : When 0.77 g of Citric Acid preparations is dissolved in 5 mL of water, which is tested by Arsenic Limit Test, its content should not be more than 1.33 ppm.

(4)Lead : When 5.0 g of Citric Acid Preparations is tested by Atomic Absorption Spectrophotometry or Inductively Coupled Plasma Emission Spectroscopy, its content should not be more than 0.5ppm.

(5) Mercury : When Citric Acid preparations is tested by Mercury Limit Test, its content should not be more than 1.0 ppm.

(6) Calcium : 1 g of Citric Acid is dissolved in 10 mL of water, which is neutralized with ammonia solution. When 1 mL of ammonium oxalate solution is added, it should not be turn turbid.

(7) Coloring Substance by Sulfuric Acid : 5 mL of sulfuric acid is added to 0.5 g of Citric acidis, dissolved by heating at 90°C for 1 hour. When the color of the solution is observed with a white background, the color should not be deeper than that of the color standard K.

(8) Polynuclear Aromatic Hydrocarbon : 25 g of Citric Acid is dissolved in 30 mL of water by heating at about 50°C. After cooling, the solution is extracted 3 times with 20 mL each of n-hexane for UV absorption spectrophotometry grade. It is centrifuged at 2,500 ~ 3,000 rpm for about 10minutes and concentrated to 1 ~ 2 mL by evaporating n-hexane out. After cooling, n-hexane (for UV absorption spectrophotometry grade) is added to the concentrate to bring the total volume to 10 mL, Test Solution. Absorbance of test solution is measured at 260 ~ 350 nm with 1 cm cell. The difference in absorbance (compared to reference solution) should not be more than 0.05 in this range. In this case, use the reference solution obtained by following method. To 30 mL of water, extract 3 times with 20 mL of n-hexane(UV absorption spectrophotometry grade) repeatedly, and follow the same procedure as test solution.

(9) Isocitric acid : Weigh 0.5g of Citric Acid, heat at 105°C for 3 hours, cool, and dissolve in 10 mL of acetone. Measure 0.005 mL of the test solution, and perform Paper Chromatography without using a control solution. No more than one spot is observed. For the filter paper, use a No. 2 filter paper for chromatography, and stop the development when the developing solvent rises about 25 cm. Then air-dry, and spray with bromophenol blue TS for citric acid. Allow a n-butanol-formic acid-water

mixture(8:3:2) to stand, and use the upper layer obtained as the developing solvent.

Test of Bacterial Activity Citric acid preparations is tested as directed under Test of Bacterial Suspension in Test of Bacterial Activity. It should be appropriate.

Iodine Preparations

Definition Iodine preparations contains Iodine as an active ingredient. However, Potassium Iodine can be added for dilution or stability in quality.

Compositional Specifications of Iodine preparations

Description Iodine preparations occurs as reddish brown liquid having a characteristic odor.

Purity (1) Chloride and Bromide : Dissolve 1.0 g of Iodine preparations in 20 mL of water and shake it to mix and filter it. Add 1 drop of sulfurous acid water(1→5) to 10 mL of the balance solution until yellow color is clear. After adding 1 mL of ammonia solution to this solution, again add 1 mL of silver nitrate solution little by little and water to make to 20 mL. Shake it to mix and filter it. 2 mL of the first balance solution is discarded. When 10 mL of the next balance solution is taken and 2.0 mL of nitric acid and water are added to make to 20 mL, the turbidity of solution should not be darker than a reference solution. Add 5 mL of water to 0.20 mL of 0.01 mol hydrochloric acid, 2.5 mL of ammonia solution, 1 mL of silver nitrate solution, 2.0 mL of nitric acid and water to make to 20 mL, this solution is used as a reference solution.

(2) Lead : When 5.0 g of Iodine preparations is tested by Atomic Absorption Spectrophotometry or Inductively Coupled Plasma Emission Spectroscopy, its content should not be more than 10 ppm.

Test of Bacterial Activity Iodine preparations is tested as directed under Test of Bacterial Suspension in Test of Bacterial Activity. It should be appropriate.

Chlorine Dioxide Preparations

Definition Chlorine Dioxide Preparations contain Chlorine Dioxide as an active ingredient. However, Diluent, stabilizers, dissolving agents, etc. can be added for dilution or stability in quality.

Compositional Specifications of Chlorine Dioxide preparations

Description Chlorine Dioxide preparations occurs as pale yellow liquid having a pungent odor.

Identification When the mixed solution(5 mL of acetic acid and 1 g of potassium iodine) is added to 5 mL of this diluted solution(10 mg/L), the color of this solution become yellow. Again when 1 mL of starch solution is added, the color of this solution become dark blue.

Test of Bacterial Activity Chlorine Dioxide preparations is tested as directed under Test of Bacterial Suspension in Test of Bacterial Activity. It should be appropriate.

Lactic Acid Preparations

Definition Lactic Acid preparations contains Lactic Acid as an active ingredient. However, Diluent, stabilizers, dissolving agents, etc. can be added for dilution or stability in quality.

Description Lactic Acid preparations is odorless or have a characteristic odor.

Identification (1) An aqueous solution of Lactic Acid (1→10) is acidic.

(2) Lactic Acid preparations responds to the tests for Lactic Acid Salt in Identification.

Purity (1) Clarity and Color of Solution : Concentrate the Lactic Acid to 80% concentration. Take 10 g of the solution, add 12 mL of ether, and mix. The solution is clear, or passes the following test. Filter the solution mixed with ether through a glass filter (1G3), wash the residue three times with 10 mL of ether each time, then once with 10 mL of acetone, dry the residue together with the filter under reduced pressure at 50°C for 14 hours. The amount of the residue is not more than 0.07 g.

(2) Citric Acid, Oxalic Acid, Tartaric Acid, and Phosphoric Acid : When Lactic Acid (corresponding to 0.8 g of Lactic Acid) is dissolved in 10 mL of water, where 40 mL of potassium hydroxide solution is added and boiled for 2 minutes, it should not turn turbid

(3) Sulfate : When Lactic Acid (correspond in to 0.8 g of Lactic Acid) is tested by Sulfate Limit Test, its content should not be more than the amount that corresponds to 0.2 mL of 0.01 N sulfuric acid.

(4) Cyanide : Weigh Lactic Acid (corresponding to 0.8 g of Lactic Acid), and dissolve in water to make 100 mL. Take 10 mL of this solution. transfer into a Nestler tube, add 1 drop of phenolphthalein solution, and add sodium hydroxide solution (1→10) until the color of the solution changes to pink. Add 1.5 mL of sodium hydroxide solution (1→10) and water to make 20 mL, and heat in a water bath for 10 minutes. Cool, neutralize with diluted acetic acid (1→20), and after the pink color of the solution disappears, add 1 drop. Add 10 mL of phosphate buffer (pH 6.8) and 0.25 mL of chloroamine T, stopper tightly, shake gently, allow to stand for 3 ~ 5 minutes, add 15 mL of pyridine-pyrazolone solution and water to make 50 mL, and allow to stand at about 25°C for 30 minutes. The color of the solution does not change to blue.

(5) Arsenic : When Lactic Acid (corresponding to 0.4 g of Lactic Acid) is mixed with 5 mL of water, and add water to make 10 mL. Take 5 mL of this solution and test by Arsenic Limit Test and its content should not be more than 4 ppm.

(6) Lead : When 5.0 g of Lactic Acid is tested by Atomic Absorption Spectrophotometry or Inductively Coupled Plasma Emission Spectroscopy, its content should not be more than 2.0 ppm.

(7) Mercury : When Lactic Acid is tested by Mercury Limit Test, its content should not be more than 1.0 ppm.

(8) Iron : Lactic Acid (corresponding to 0.8 g of lactic acid) transfer into a Nestler Tube, and dissolve in 6 mL of dilute nitric acid (1→10) and 10 mL of water, add water to make 25 mL. Use this solution as the test Solution. 50 mg of ammonium persulfate and 5 mL of ammonium thiocyanate solution (2→25) are added to Test Solution. The resulting color should not be deeper than that of a solution prepared

by treating 1 mL of iron standard solution by the same procedure as the Test Solution.

(9) Chlorides : Accurately weigh a portion of sample equivalent to about 5 g of lactic acid, dissolve in 50mL of water, and neutralize to litmus with sodium hydroxide solution. (1 in 4). Add 2 mL of potassium chromate TS and titrate with 0.1N silver nitrate to the first appearance of a red tinge, its content should not be more than 0.2%.

1 mL of 0.1N silver nitrate solution = 3.545mg Cl

(10) Readily Carbonizable Substances : Weigh Lactic Acid (corresponding to 2 g of lactic acid) adjust to 15°C, gradually superimpose on top of 5 mL sulfuric acid pre-adjusted to 15°C, and keep at 15°C. Even if a band is formed at the interface within 15 minutes, its color should not change to dark gray.

(11) Volatile Fatty Acid : Lactic Acid (corresponding to 2 g of lactic acid), where water is added to bring the volume to 5 mL, if necessary, is heated in a water bath, it should not generate an odor of lactic acid.

(12) Methanol : To Lactic Acid (corresponding to 4 g of lactic acid), add 8 mL of water and 5 g of calcium carbonate, distill the solution, take about 5 mL of the initial distillate, and add water to make 100 mL. Use this solution as the test solution. Measure 1.0 mL of the test solution, add 0.1 mL of phosphoric acid (1→20) and 0.2 mL of potassium permanganate solution (1→300), allow to stand for 10 minutes, add 0.4 mL of anhydrous sodium sulfite solution (1→5) and 3 mL of sulfuric acid, then add 0.2 mL of chromotropic acid solution. The color of the solution is not darker than that of the following reference solution. Measure 1.0 mL of methanol. add water to make 100 mL, measure 1.0 mL of this solution, and add water to make 100 mL. Use this solution as the solution.

Test of Bactericidal Activity When Lactic Acid preparations is tested by Test Method of Bacterial Suspension in Test of Bactericidal Activity, it should be appropriate.

5. Use Level of Food Contact Surface Sanitizing Solution

Hydrogen Peroxide Preparations

Hydrogen Peroxide should be only used for sanitizing food contact material, container, and packaging below.

1. When using sterilizing and fumigating of food contact surfaces, the usage is as below
 - 1) Food-contact surfaces in public eating places (including food service providing food for less than 50 persons at a time) : not more than 91mg/L (as Hydrogen Peroxide)
 - 2) Dairy-processing equipment : not more than 465mg/L (as Hydrogen Peroxide)
 - 3) Food-processing equipment : not more than 1,100mg/L (as Hydrogen Peroxide)
2. When using for sterilization of food container and packaging
 - 1) It should be removed by rinsing with sterile water or drying with hot air.
 - 2) Residual quantity test below should be proceeded, the residue of Hydrogen Peroxide in container.packaging should be not more than 0.5mg/L.

Residual test

Preparation of a Test Solution: After sterilizing the containers and packages for food, rinse them with sterilized water or dry them with hot air. Put water into the container or package before the final food is contained. and use it as a test solution.

Test Operation: Take exactly 20 mL of a test solution, add 50 mL of 1N sulfuric acid, add 3~5 drops of a ferriin solution, shake it occasionally, and titrate it with a 0.001N sodium sulfate solution until a pale red color disappears. Perform the blank test in the same way.

$$1 \text{ mL of } 0.001\text{N sodium sulfate solution} = 17\mu\text{g H}_2\text{O}_2$$

Test solution

Ferriin test solution : Dissolve 0.7g of ferrous sulfate(seven hydrate) and 1.76g of o-phenanthroline hydrochloride(one hydrate) in water to prepare an 100mL solution.

Peroxyacetic Acid Preparations

Peroxyacetic acid should be only used for sanitizing food contact material, container, and packaging below.

1. When using sterilizing and fumigating of food contact material, the usage is as below
 - 1) Food-contact surfaces in public eating places (including food service providing food for less than 50 persons at a time)

Peroxyacetic Acid	Not more than 58mg//
-------------------	----------------------

Hydrogen peroxide	Not more than 91mg//
Peroxyoctanoic acid	Not more than 52mg//
Octanoic acid	Not more than 52mg//
(1-hydroxyethylidene)bis-, phosphoric acid	Not more than 14mg//
1-Octanesulfonic acid, sodium salt	Not more than 46mg//

2) Dairy-processing equipment

Peroxyacetic Acid	Not more than 315mg//
Hydrogen peroxide	Not more than 465mg//
Peroxyoctanoic acid	Not more than 122mg//
Octanoic acid	Not more than 176mg//
(1-hydroxyethylidene)bis-, phosphoric acid	Not more than 34mg//
1-Octanesulfonic acid, sodium salt	Not more than 297mg//

3) Food-processing equipment

Peroxyacetic Acid	Not more than 315mg//
Hydrogen peroxide	Not more than 1,100mg//
Peroxyoctanoic acid	Not more than 122mg//
Octanoic acid	Not more than 234mg//
(1-hydroxyethylidene)bis-, phosphoric acid	Not more than 34mg//
1-Octanesulfonic acid, sodium salt	Not more than 312mg//

2. When using for sterilization of food container and packaging

- 1) It should be removed by rinsing with sterile water or drying with hot air.
- 2) Residual quantity test below should be proceeded, the residue of Hydrogen Peroxide in container.packaging should be not more than 0.5mg/l.

Citric Acid Preparations

Citric acid should be only used for sanitizing food contact material below.

1. Food-contact surfaces in public eating places (including food service providing food for less than 50 persons at a time)
2. Dairy-processing equipment
3. Food-processing equipment

Ethanol Preparations

Ethanol should be only used for sanitizing food contact material below. The usage is as below.

1. Food-contact surfaces in public eating place (including food service providing food for less than 50 persons at a time)
2. Dairy-processing equipment
3. Food-processing equipment

Quaternary ammonium Compounds, n-Alkyl(C₁₂-C₁₈)benzyl dimethyl Chloride Preparations

Quaternary ammonium Compounds, n-Alkyl(C₁₂-C₁₈)benzyl dimethyl Chloride should be only used for sanitizing food contact material below. The usage is as below.

1. Food-contact surfaces in public eating places (including food service providing food for less than 50 persons at a time)

Quaternary ammonium compounds, alkyl(C ₁₂ -C ₁₈)benzyl-dimethyl chlorides	Not more than 200mg// (as sum of quaternary ammonium, if used with other quaternary ammonium, not more than 200mg// as sum of quaternary ammonium)
Quaternary ammonium compounds, n-alkyl(C ₁₂ -C ₁₄)dimethyl thylbenzyl ammonium chloride (average molecular weight 377 to 384)	Not more than 200mg// (as sum of quaternary ammonium, if used with other quaternary ammonium, not more than 200mg// as sum of quaternary ammonium)

Quaternary ammonium compounds, n-alkyl(C ₁₂ -C ₁₈) dimethyl ethylbenzyl ammonium chloride, average molecular weight(in amu), 384	Not more than 200mg// (as sum of quaternary ammonium, if used with other quaternary ammonium, not more than 200mg// as sum of quaternary ammonium)
Quaternary ammonium compounds, di-n-alkyl(C ₈ -C ₁₀) dimethyl ammonium chloride (average molecular weight 332 to 361)	Not more than 150mg// (as sum of quaternary ammonium, if used with other quaternary ammonium, not more than 200mg// as sum of quaternary ammonium)
Poly(hexamethylene biguanide) hydrochloride	Not more than 550mg//

2. Dairy-processing equipment

Quaternary ammonium compounds, alkyl(C ₁₂ -C ₁₈)benzyl-dimethyl chlorides	Not more than 200mg/l (as sum of quaternary ammonium, if used with other quaternary ammonium, not more than 200mg/l as sum of quaternary ammonium)
Quaternary ammonium compounds, n-alkyl(C ₁₂ -C ₁₄)dimethyl ethylbenzyl ammonium chloride (average molecular weight 377 to 384)	Not more than 200mg/l (as sum of quaternary ammonium, if used with other quaternary ammonium, not more than 200mg/l as sum of quaternary ammonium)
Quaternary ammonium compounds, n-alkyl(C ₁₂ -C ₁₈) dimethyl ethylbenzyl ammonium chloride, (average molecular weight, 384)	Not more than 200mg/l (as sum of quaternary ammonium, if used with other quaternary ammonium, not more than 200mg/l as sum of quaternary ammonium)

Quaternary ammonium compounds, di-n-alkyl(C8-C10) dimethyl ammonium chloride (average molecular weight 332 to 361)	Not more than 150mg/l (as sum of quaternary ammonium, if used with other quaternary ammonium, not more than 200mg/l as sum of quaternary ammonium)
Poly(hexamethylene biguanide) hydrochloride	Not more than 550mg/l

3. Food-processing equipment

Quaternary ammonium compounds, alkyl(C ₁₂ -C ₁₈)benzyl-dimethyl chlorides	Not more than 200mg// (as sum of quaternary ammonium, if used with other quaternary ammonium, not more than 400mg// as sum of quaternary ammonium)
Quaternary ammonium compounds, n-alkyl(C ₁₂ -C ₁₄)dimethyl thylbenzyl ammonium chloride (average molecular weight 377 to 384)	Not more than 200mg// (as sum of quaternary ammonium, if used with other quaternary ammonium, not more than 400mg// as sum of quaternary ammonium)
Quaternary ammonium compounds, n-alkyl(C ₁₂ -C ₁₈) dimethyl ethylbenzyl ammonium chloride, (average molecular weight, 384)	Not more than 200mg// (as sum of quaternary ammonium, if used with other quaternary ammonium, not more than 400mg// as sum of quaternary ammonium)
Quaternary ammonium compounds, di-n-alkyl(C ₈ -C ₁₀) dimethyl ammonium chloride (average molecular weight 332 to 361)	Not more than 240mg// (as sum of quaternary ammonium, if used with other quaternary ammonium, not more than 400mg// as sum of quaternary ammonium)
Poly(hexamethylene biguanide) hydrochloride	Not more than 550mg//

1-Decanaminium, N-decyl-N,N-dimethyl-, Chloride Preparations

1-Decanaminium, N-decyl-N,N-dimethyl-, Chloride should be only used for sanitizing food contact surface for preparing and processing of food. The usage should be not more than 200mg/l (as quaternary ammonium).

Iodine Preparations

Iodine should be only used for sanitizing food contact material below. The usage is as below.

1. Food-contact surfaces in public eating places (including food service providing food for less than 50 persons at a time)

Iodine	Not more than 25mg// (as titrated iodine, if used with other iodide, not more than 25mg// as sum of titrated iodine)
Iodine Potassium	Not more than 25mg// (as titrated iodine, if used with other iodide, not more than 25mg// as sum of titrated iodine)

2. Dairy-processing equipment

Iodine	Not more than 25mg// (as titrated iodine, if used with other iodide, not more than 25mg// as sum of titrated iodine)
Iodine Potassium	Not more than 25mg// (as titrated iodine, if used with other iodide, not more than 25mg// as sum of titrated iodine)

3. Food-processing equipment

Iodine	Not more than 25mg// (as titrated iodine, if used with other iodide, not more than 25mg// as sum of titrated iodine)
Iodine Potassium	Not more than 25mg// (as titrated iodine, if used with other iodide, not more than 25mg// as sum of titrated iodine)

Sodium Dichloroisocyanurate Preparations

Sodium Dichloroisocyanurate should be only used for sanitizing food contact material below.

1. Food-contact surfaces in public eating places (including food service providing food for less than 50 persons at a time) : not more than 100mg/l (as active chlorine)
2. Dairy-processing equipment : not more than 100mg/l (as active chlorine)
3. Food-processing equipment : not more than 100mg/l (as active chlorine)

Hypochlorous Acid, Sodium Salt Sodium Hypochlorite Preparations

Ethanol should be only used for sanitizing food contact material below. The usage is as below.

1. Food-contact surfaces in public eating place (including food service providing food for less than 50 persons at a time) : not more than 200mg/l (as active chlorine)
2. Dairy-processing equipment : not more than 200mg/l (as active chlorine)
3. Food-processing equipment : not more than 200mg/l (as active chlorine)

Hypochlorous Acid Water Preparations

Hypochlorous Acid Water should be only used for sanitizing food contact material below. The usage is as below.

1. Food-contact surfaces in public eating places (including food service providing food for less than 50 persons at a time) : not more than 200mg/l (as active chlorine)
2. Dairy-processing equipment : not more than 200mg/l (as active chlorine)
3. Food-processing equipment : not more than 200mg/l (as active chlorine)

Poly(hexamethylenebiguanide)hydrochloride Preparations

Poly(hexamethylenebiguanide)hydrochloride should be only used for sanitizing food contact material below. The usage is as below.

1. Food-contact surfaces in public eating places (including food service providing food for less than 50 persons at a time)

Poly(hexamethylenebiguanide)hydrochloride	Not more than 550mg//
Quaternary ammonium compounds, di-n-alkyl(C ₈ -C ₁₀) dimethyl ammonium chloride (average molecular weight 332 to 361)	Not more than 150mg// (as quaternary ammonium)

2. Dairy-processing equipment

Poly(hexamethylenebiguanide)hydrochloride	Not more than 550mg//
Quaternary ammonium compounds, di-n-alkyl(C ₈ -C ₁₀)	Not more than 150mg//

dimethyl ammonium chloride (average molecular weight 332 to 361)	(as quaternary ammonium)
--	--------------------------

3. Food-processing equipment

Poly(hexamethylenebiguanide)hydrochloride	Not more than 550mg/l
Quaternary ammonium compounds, di-n-alkyl(C ₈ -C ₁₀) dimethyl ammonium chloride (average molecular weight 332 to 361)	Not more than 240mg/l (as quaternary ammonium)

Chlorine Dioxide Preparations

Chlorine Dioxide Preparations should be only used for sanitizing food contact material below. The usage is as below.

1. Food-contact surfaces in public eating places (including food service providing food for less than 50 persons at a time) : not more than 200mg/l
2. Dairy-processing equipment : not more than 200mg/l
3. Food-processing equipment : not more than 200mg/l

Lactic Acid Preparations

Lactic Acid Preparations should be only used for sanitizing food contact material below. The usage is as below.

1. Food-contact surfaces in public eating places (including food service providing food for less than 50 persons at a time)
2. Dairy-processing equipment
3. Food-processing equipment

IV. General Test Methods

1. Gas Chromatography

This method is to identify and quantify the separated phases from an evaporated sample. The evaporated sample gets separated by the interaction with column filler phase in the column while is carried by a gas (carrier gas). If the column filler is solid, it is called gas-solid chromatography. If the column filler consists of inert solid coated with liquid, it is called gas-liquid chromatography.

In the former case, passing of solution is delayed by absorption or expulsion and for the latter case, it is done by distribution between gaseous mobile phase and stationary liquid. The components that affects the separation include the flow rate of carrier gas, length and inside diameter of column, particle size of solid porous support material, type of liquid used, the relative volume of liquid vs. solid porous support material, and temperature.

A. Apparatus

Basic equipment for Gas Chromatography consists of carrier gas inlet, sample injection port, column, detector and data recording equipment.

B. Procedure

Unless stated otherwise, the following method is to be used. After pre-setting measurement value, column detector temperature and carrier gas flow rate of the carrier gas are set up by the conditions as specified for each item. A prescribed volume of test solution or standard solution specified for each item is injected into the sample injection port using a micro-syringe for gas chromatography. The separated components are collected by a detector and a chromatogram is obtained using a recorder.

The peak location of the component on chromatogram is indicated by retention time (time after injecting test solution up to the peak position) or retention volume (retention time x carrier gas volume). These values are characteristic of each substance under certain conditions.

These are used to identify the components in the sample

Quantitative information can be obtained from the peak area or peak height from a chromatogram. Generally, one of the following methods is used.

(1) Internal Standard Method

A set of standard solutions are prepared by incrementally adding a known amount of standard test material to a certain amount of internal standard material as specified for each item. A certain amount of each standard solution is injected. A calibration curve is prepared from the obtained chromatogram by plotting the ratios of peak areas or peak heights between standard test material and internal standard material (vertical axis) vs. the ratio between the amounts of standard test material and internal

standard or the amount of standard test material (horizontal axis).

A test solution is prepared by the method specified for each item. The same amount as in standard solution is added to the test solution. Then a chromatogram is obtained under the same conditions as in standard solutions. The amount of the component is obtained from the ratio of peak area or peak height between the test component and the internal standard. The internal standard is selected so that it is stable and completely separable from the test component as well as other components in the test material.

(2) Absolute Calibration Curve Method

A set of standard test solutions are prepared with incremental concentrations. A certain amount of each solution is precisely injected. A calibration curve is prepared from the obtained chromatogram by plotting the peak areas or peak heights of the standard test component (vertical axis) vs. the amount of the standard test component. material and internal standard or the amount of standard test material (horizontal axis). A test solution is prepared by the method specified for each item. A chromatogram is obtained under the same conditions as the calibration curve. The content of the test component is obtained from the calibration curve. In this method, all the test conditions should be kept strictly consistent.

(3) Area Percentage Method

The peak area sum of all the components is set as 100. The content ratio of each component is obtained from peak area ratio. Peak height and peak area in (1), (2), and (3) are usually measured by the following methods.

(A) Peak Height Method

A vertical line is drawn from the peak vertex to the horizontal axis. A tangent line connecting the base line of the peak is drawn. The length between the peak vertex and the intersection is measured.

(B) Peak Area Method

- 1) Width at half-height method : Peak width at the half maximum is multiplied by the peak height.
- 2) Weight Method : The peak is cut out from the chromatogram and weighed directly.
- 3) Automatic Integration Method : Signals from the detector is integrated using an automatic integrator.

Note : Reagents and solutions used in the test should not show any peaks that interfere with the measurement.

2. Residue on Ignition

Sulfuric acid is added to the sample, which is then heat treated to test the amount of residues. Unless otherwise specified, 1 ~ 2 g of sample is precisely weighed into a previously weighed platinum, quartz, or porcelain crucible. sample is wetted with sulfuric acid and slowly reduced to ash by heating. After cooling, 1 mL of sulfuric acid is added to the crucible, which is then slowly heated until sulfuric acid vapor subsides. Then the crucible is heat treated at 450~550°C until the residues turn white. The crucible is cooled in a desiccator and weighed. If there is no specification for the heat treatment time, it is heated until the weight becomes constant.

3. Loss on Drying and Loss on Ignition

This method is used to measure the amount of water content and other volatile material in a sample upon drying or heat treatment.

A. Loss on Drying

If a sample is a large crystal or lump, it is ground quickly to a diameter of approximately 2 mm or less. Unless otherwise specified, 1 ~ 2 g of the ground sample is laid out flatly in a weighing bottle(which is previously dried for approximately 30 minutes and weighed) to form a layer of 5 mm or less and dried in a drier without a cap as specified for each sample. The cap is placed on the bottle, which is then weighed. If it is dried by heating, the weight is measured after cooling. If the sample melts at a temperature lower than the specified drying temperature, it is dried for 1 ~ 2 hours at a temperature which is 5~10°C lower than the melting point and dried at the specified temperature.

B. Loss on Ignition

Should follow the procedure in loss on drying. Unless otherwise specified, heat treatment temperature is carried out at 450~550°C and platinum, quartz or porcelain crucible is used instead of weighing bottle.

4. Refractive Index

Refractive Index of a material is a light velocity ratio within a material vs. in vacuum. It is the ratio of incident angle vs. refraction angle of the sinusoidal wave of the light. Generally, refractive index varies with wavelength and temperature. In this test, refractive index (n) is measured using D (589 nm) from sodium spectrum as a light source at a temperature $t^{\circ}\text{C}$ in air. Unless otherwise specified, refractive index is measured using Abbe refractometer at a temperature within $\pm 0.2^{\circ}\text{C}$ of the specified temperature.

5. Methoxyl Determination

This method is to quantitatively analyze methoxyl group by the following procedure. Hydriodic acid is added to the sample, which generates methyl iodide upon heating. Methyl iodide is oxidized with bromine, where potassium iodide and diluted sulfuric acid. The resulting iodine is titrated with sodium thiosulfate solution.

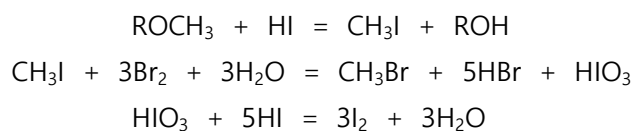

A. Apparatus

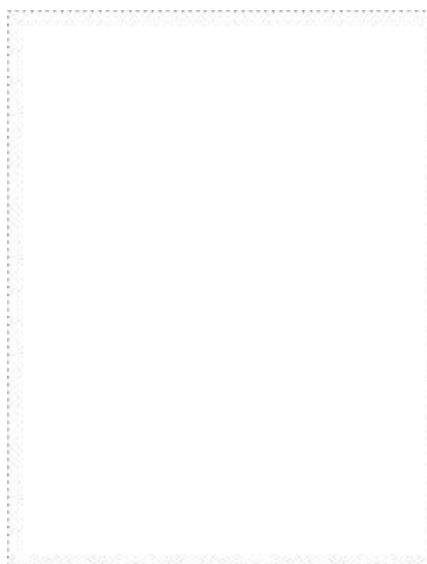

The apparatus is depicted in the figure below (unit : mm).

- A : flask for decomposition
- B : gas inlet tube
- C : ground joint
- D : air cooling part
- E : gas washing part
- F : glass stopper
- G : round face ground joint
- H : gas pipe
- J : absorbent tube,
- K : gas outlet tube

B. Preparation of Scrubbing Solution and Absorbing Solution

- 1) Washing solution : Red phosphor (1 g) is dispersed in 100 mL of water.
- 2) Absorbent solution : Potassium acetate (15 g) is dissolved in 150 mL mixture of glacial acetic acid and anhydrous acetic acid (9:1), 145 mL of which is mixed with 5 mL of bromine. This solution is prepared just before use.

C. Procedure

Gas washing part E is filled to 1/2 with washing solution and absorbent tube J is filled with approximately 20 mL of absorbent solution. sample, which corresponds to approximately 6.5 mg of methoxyl group ($\text{CH}_3\text{O} : 31.03$), is precisely weighed into a flask for decomposition A, where boiling stone and approximately 6 mL of hydroiodic acid are added. The ground joint C of A is wetted with 1 drop of hydroiodic acid, connected to an air condenser D, which is then connected to the round face ground joint G where appropriate amount of silicone grease is applied. Nitrogen or carbon dioxide is introduced through the gas inlet B. Using an appropriate regulator, the gas flow rate is adjusted to roughly 2 bubbles per second through the gas outlet E. A is immersed in an oil bath, which is heated so that it reaches 150°C in 20 ~ 30 minutes. It is then boiled for 60 minutes at that temperature. After removing the oil bath, it is cooled in air and G is removed. The content in J is transferred into a 500 mL Erlenmeyer flask (with a stopper) that is filled with 10 mL of sodium acetate solution is (1→5). J is washed several times with water into the flask. Water is added to bring the total volume to approximately 200 mL. While shaking, formic acid is drop-wise added until the red color of bromine disappears and 1 mL of formic acid is added. After adding 3 g of potassium iodide and 15 mL of dilute sulfuric acid, a cap is placed and the flask is shaken gently and set aside for 5 minutes. The separated iodine is titrated with 0.1 N sodium thiosulfate solution (indicator : 1 mL of starch solution). Separately, a blank test is carried out by following the same procedure.

$$0.1 \text{ N sodium thiosulfate solution } 1 \text{ mL} = 0.5172 \text{ mg CH}_3\text{O}$$

6. Thin Layer Chromatography

A. Preparation of Thin Layer Plate

A glass plate with smooth surface and uniform thickness (50×200 mm or 200×200 mm) is fixed on a thin layer preparation plate. Glass surface is wiped clean with gauze wetted with alcohol. An appropriate amount of absorbant is well dispersed in water (approximately 1:1) by shaking for approximately 30 seconds. Using an applicator, the glass plate is uniformly coated with the dispersion (0.2 ~ 0.3 mm thickness). After setting aside for approximately 10 minutes, it is dried for 30 minutes at 105~120°C(or follow other directions if specified), activated, and stored in a desiccator.

B. Procedure

Developing solution is filled up to approximately 10 mm from the bottom of the developing bath. A cap is placed on the bath so that the bath is saturated with the vapor of the developing solvent. Test solution and standard solution are spotted at 2 cm from the bottom of the thin layer plate. These spots are separated approximately 1.5 cm from each other and their diameter should not exceed 5 mm. Spots are completely dried and the plates are carefully inserted into the developing bath so that the solvent doesn't touch the spots. The bath is sealed with a cap and the solvent is developed up to 10 ~ 15cm (approximately 15 ~ 60 minutes). The plates are air-dried and overserved under a UV light (254 nm or 360 nm) or sunlight. If necessary, a spray reagent is used and the spots are compared. Rf values are obtained by the following equation.

7. Quantitative Test for Generated Gas

A. Apparatus

The apparatus is depicted in the figure below (unit : mm).



A : Thick Erlenmeyer flask for gas generation (approximately 250 mL volume)

B : Gas burette (300 mL volume with 0.5 mL graduation)

C : Level bottle (approximately 600 mL volume)

D and E : Rubber tube

F, G and H : Rubber stopper

Dilute sulfuric acid is added to a level bottle C so that a weak acidity is established with methyl orange. However, when ammonia is being measured, distilled water is used instead of diluted sulfuric acid. After the temperature reaches 85°C by adding 200 mL of boiling water to gas generation flask A, 2 g of sample (2 g of sample with a mixing ratio given in the directions if it is Type 2 synthetic swelling agent) is wrapped in Oprite paper, which is then again wrapped with a filter paper. It is then placed in the flask, which is immediately connected to the gas burette with a rubber tube. The flask is gently shaken occasionally. The volume of the generating gas is measured in 3 minutes.

8. Arsenic Limit Test

This method is to test the tolerance level of arsenic contained in a sample. The amount is expressed by the amount of arsenic trioxide (As₂O₃).

A. Colorimetry

1) Preparation of Test Solution

The preparation of the test solution is carried out according to the following method. However, in the case of items not listed in the following items, preparations should be made with reference to the preparation of similar items.

(1) Method 1

Weigh the amount of sample specified by each of the following items, and unless other wise stipulated add 5 mL of water. And if necessary, the test solution is prepared by heating and dissolving.

Items	the amount
Disodium 5'-Guanylate, Manganese Citrate, Copper Gluconate, Manganese Gluconate, Zinc Gluconate, L-Glutamine, Glycerin, Glycine, Sodium Dehydroacetate, L-Lysine, L-Lysine Monohydrochloride, L-Leucine, Disodium 5'-Ribonucleotide, D-Ribose, D-Mannitol, D-Maltitol, Sodium Metaphosphate, Potassium Metaphosphate, Betaine, DL-Malic Acid, Sodium DL-Malate, Disodium Dihydrogen Pyrophosphate, L-Serine, Potassium Sorbate, Calcium Sorbate, D-Sorbitol, D-Sorbitol Solution, Oxalic Acid, Disodium 5'-Cytidylate, L-Arginine, Sodium L-Ascorbate, Aspartame, Sodium Benzoate, DL-Alanine, L-Alanine, Erythorbic Acid, Sodium Erythorbate, Magnesium Chloride, Ammonium Chloride, Potassium Chloride, Calcium Chloride, Disodium 5'-Uridylate, Disodium 5'-Inosinate, Sodium Diacetate, Itaconic Acid, Sodium Phosphate, Tribasic, Potassium Phosphate, Tribasic, Sodium Phosphate, Dibasic, Ammonium Phosphate, Dibasic, Potassium Phosphate, Dibasic, Sodium Phosphate, Monobasic, Ammonium Phosphate, Monobasic, Potassium Phosphate, Monobasic, Disodium DL-Tartrate, Disodium L-Tartrate, Sodium Iron Chlorophyllin, Sodium Acetate, Calcium Acetate, Ammonium Bicarbonate, Ammonium Carbonate, L-Theanine, L-Threonine, Triacetin, Sodium Pantothenate, Calcium Pantothenate, Sodium Propionate, Calcium Propionate, L-Proline, Sodium Pyrophosphate, Potassium Pyrophosphate, Succinic Acid, Disodium Succinate, Sulfuric Acid, Magnesium Sulfate, Zinc	0.25g

Items	the amount
Sulfate, Ferrous Sulfate, -Histidine, L-Histidine Monohydrochloride	
Sodium sulfate	0.33g
Monosodium L-Glutamate	0.4g
Sodium Polyphosphate, Potassium Polyphosphate	0.5g
Citric acid, Trisodium citrate, Potassium Citrate, Glacial Acetic Acid	0.77g
D-Xylose	1g
Aluminium Ammonium Sulfate, Aluminium Potassium Sulfate	0.25g (Taken after drying at 200°C, 4hr)
Glucono- δ -Lactone, Gluconic Acid, L-Valine, sucralose, Potassium Iodide, Disodium Ethylenediaminetetraacetate, Calcium Disodium Ethylenediaminetetraacetate, Potassium DL-Bitartrate, Potassium L-Bitartrate, Potassium Bicarbonate, DL-Threonine, Fumaric Acid, Monosodium Fumarate, Potassium Sulfate	0.25g, Water 10mL
Manganese Sulfate	0.25g, Water 25mL
Phosphoric Acid	0.38g, Water 20mL
Lactitol	0.39g(anhydrous), Water 20mL
Sodium Lactate	0.77g, Water 10mL

Items	the amount
Potassium Gluconate	0.25g, Water 10mL
hydrochloric acid	5mL, Add water to mass up to 50 mL, and then take 5 mL of it.
Iron, Electrolytic	filtrate from acid insolubles test, add water to 100 mL, and then take 25 mL of it.
Lactic Acid	0.5g, Add 5 mL of water and mix. After mixing add more water to 10 mL, and then take 5 mL of it.
Phytic Acid	0.66g, Add water to 10 mL, and then take 5 mL of it.
Propylene Glycol	10g, Add water to 200 mL, and then take 5 mL of it.
Iron, Reduced	filtrate from acid insolubles test, add water to 100 mL, and then take 12.5 mL of it.

(2) Method 2

Add the following amount of items to a crucible made of made of platinum, quartz, or porcelain. Add 10 mL of magnesium nitrate in ethanol (1 → 50), and heat them with ethanol to slowly burn it on 450 to 550 °C to make it ash. If the hydrocarbon is present, immerse it in a small amount of nitric acid, heat it again, and then burn it in 450 to 550 °C to make it ash. After cooling it down, add 3 mL of hydrochloric acid to the residue, which is then dissolved by heating in a water bath. And then use it as a test

solution.

Items	the amount
<p>Gum Ghatti, Persimmon Color, Masticatory Substances, Cellulose, Microcrystalline, Cinnamic Acid, Kaoliang Color, Guar Gum, Koji, Silicone Resin, β-Glucanase, Glucomannan, Glucosamine, α-Glucosidase, Glucoamylase, Glucose Oxidase, Glucose Isomerase, Ferrous Gluconat, Glutaminase, L-Glutamic Acid, Glycerin Esters of Fatty Acids, Laver Color, Natamycin, Dextranase, Dextran , Copper Chlorophyll, Potassium Copper Chlorophyllin, Butylated Hydroxy Toluene, 5'-Deaminase, Diastase(Diastatic Power, DP), Lauric Acid, Lac Color, Lactase, Lecithin, Rosin, Locust Bean Gum, Rutin,, Lipase, Tagetes Extract, Maltogenic Amylase, Maltotriohydrolase, Maltol, Methyl β-Naphthyl Ketone, Methyl Cellulose, Methyl ethyl cellulose, dl-Menthol, l-Menthol, Gallic Acid, Propyl Gallate, Hibiscus Color, Mucin, Myristic Acid, Beeswax, Vanillin, Berries Color, β-Glycosidase, Modified Hop Extract, Garden Balsam Extract, Butylated Hydroxy Anisole, Riboflavin 5'-Phosphate Sodium, L-Ascorbic Acid, dl-α-Tocopherol, Beet Red, Psyllium Seed Gum, Saffron Color, Cellulase, Sorbitan Esters of Fatty Acids, Sorbic Acid, Stearic Acid, Calcium Stearate, Sodium Stearoyl Lactylate, Calcium Stearoyl Lactylate, Spirulina Color, L-Cystine, Shea Nut Color, Curcumin, Rice Bran Wax, Adipic Acid, Arabinogalactan, Arabic Gum, Amidated Pectin, α-Amylase, α-Acetolactate decarboxylase, Calcium L-Ascorbate, L-Ascorbyl Stearate, L-Ascorbyl Palmitate, Asparaginase, L-Asparagine, L-Aspartic Acid, Azodicarbonamide, β-Apo-8'-Carotenal, Annatto Extract, Benzoic Acid, Potassium Benzoate, Calcium Benzoate, Alginic Acid, Sodium Alginate, Ammonium Alginate, Potassium Alginate, Calcium Alginate, Propylene Glycol Alginate, α-Galactosidase, Alfalfa Extract, Ammonium Phosphatides, Onion Color, Ester Gum, Ethyl Vanillin, Ethyl Cellulose, Exo-maltotetrahydrolase, γ-Oryzanol, Sepia Color, Oleic Acid, Urease, Milk Clotting Enzyme, Liquid Paraffin, Milt Protein, Isomalt, Ion Exchange Resin, Invertase, Sandalwood Red, Sucrose Esters of Fatty Acids, Xylanase, Purple Sweet Potato Color, Maize Morado Color, Purple Yam Color, Xanthan Gum, Red Radish Color, Red Cabbage Color, Gellan Gum, Crude Magnesium Chloride(Sea Water), DL-Tartaric Acid, L-Tartaric</p>	<p>0.25g</p>

Items	the amount
<p>Acid, Gibberellic Acid, Perilla Color, Tea Extract, Tea Catechin, Sesame Seed Oil Unsaponified Matter, Acetic Acid, Polyvinyl Acetate, Gardenia Red, Gardenia Blue, Gardenia Yellow, Carnauba Wax, Carrageenan, β-Carotene, Carotene, Sodium Carboxymethyl Cellulose, Calcium Carboxymethyl Cellulose, Sodium Carboxymethyl Starch, Cacao Color, Catalase, Caffeine , Capric Acid, Caprylic Acid, Candelilla Wax, Curdlan, Quercetin, Chlorophyll, Chitosanase, Chitosan, Chitin, Tara Gum, Tamarind Color, Tannase, tert-Butylhydroquinone, Tomato Color, d-Tocopherol Concentrate, Mixed, Tragacanth Gum, Transglucosidase, Transglutaminase, Trypsin, L-Tyrosine, Methyl p-Hydroxybenzoate, Ethyl p-Hydroxybenzoate, Oleoresin Paprika, Phaffia Color, Pancreatin, Palmitic Acid, Furcelleran, Ferulic Acid, Pectin, Pepsin , Grape Juice Color, Grape Skin Extract, Grape Seed Extract, Phosphodiesterase, Phospholipase, Poly-γ-glutamic acid, ϵ-Polylysine, Polybutene, Polysorbate 20, Polysorbate 60, Polysorbate 65, Polysorbate 80, Sodium Polyacrylate, Polyisobutylene, Pullulanase, Protease , Propionic Acid, Propylene Glycol Esters of Fatty Acids, Castor oil, Pecan Nut Color, Piperonal, Spice Oleoresins, Hemicellulase, Hesperidin, Heme Iron, Monascus Color, Monascus Yellow, Carthamus Red, Carthamus Yellow, Ammonium Sulfate, Enzymatically Decomposed Lecithin</p>	

Items	the amount
Licorice Extract, Biotin	0.38g
Naringin, Lactoferrin Concentrates, Microfibrillated Cellulose, Cellulose, Powdered, Petroleum Wax, Shellac, Yucca Extract, Inositol, Grapefruit Seed Extract, Koji, Sodium Caseinate, Calcium Caseinate, Quillaia Extract, Tamarind Gum, Thaumatin, dl- α -Tocopheryl Acetate, Pullulan, Enzymatically Modified Rutin, Enzymatically Modified Stevia, Enzymatically Modified Hesperidine, Hyaluronic Acid	0.5g
Nisin, Lysozyme, Food Starch Modified, Steviol Glycoside, Caramel Color, Carmine, Cochineal Extract	0.77g
Cyclodextrin Syrup, Taurine	1g

(3) Prepare a test solution by using the method specified for each of the following items.

Items	Preperation Method
Diluted Benzoyl Peroxide	Add 5 mL of dilute hydrochloric acid to 0.25 g of this item and heat it. After cooling in the ice water immediately, filter it, was the residue with 15 mL of water, and then use it as a test solution.
Hydrogen Peroxide	Take 0.25 mL of this item, add water to mass up to 10 mL. Put it in a platimun crucible, and heat it gently on the water bath to evaporate to dry up. And put a little bit of water to the residue, and then use it as a test solution.
Ammonium Persulfate	Dissolve 0.5 g of this item in the 5 mL of water, and then add 1 mL of sulfuric acid and 10 mL of sulfurous acid. And then concentrate by evaporation to make it to approximately 2 mL. After adding water to make it 10 mL, take 5 mL of it and use it as test solution.
Ferric Citrate, Ferric Ammonium Citrate	Add 5 mL of water, 1 mL of sulfuric acid and 10 mL of sulfurous acid to 0.5 g of this item, and concentrate by evaporation to make it to approximately 2 mL. Then add water to make it 10 mL, take 5 mL of it and use it as test solution.

Items	Preperation Method
Calcium Citrate	To 0.77 g of this item, add 5 mL of dilute hydrochloric acid and heat it to be dissolved, and then use it as a test solution.
Magnesium Silicate, Calcium Silicate	Take 2.5 g of this item to the 250 mL flask. After adding 50 mL of 0.5N hydrochloric acid to it, close with watch glass and slowly heat until boiling point. After boiling 30 minutes, cool down and sink the insoluble materials. Take supernatant and filter with Whatman No.3 filter paper or same kind of paper. The insoluble materials and beaker with 10 mL of hot water three times. After cooling, add 100 mL of water and take 10 mL of it, and use it as a test solution.
Diatomaceous Earth	Add 50 mL of dilute hydrochloric acid to 5 g of this item. Shake it for 15 minutes at 50°C. And then heat it on the water bath for 1 hour and add water if it is evaporated. After cooling, filter it and wash the residue of filter paper with water, and add more water to make it 100 mL. Take 2 mL of it and use it as a test solution.
Calcium Gluconate	Dissolve 0.25 g of this item with 20 mL of warm water, and use it as a test solution.
Disodium Glycyrrhizinate	<p>Take 1.25 g of this item to the flask for decomposition, add 10 mL of sulfuric acid and 10mL of nitric acid and heat until white smoke is generated. When the solution become brown, cool down and add 2mL of nitric acid and heat it again.</p> <p>This operation is repeated until the liquid turns from light to pale yellow. After cooling, 15 mL of saturated ammonium hydroxide solution is added and the mixture is heated until white smoke is generated. After cooling again, water is added to make 25 mL, and 5 mL of this solution is used as test solution.</p>

Items	Preperation Method
Gold Leaf	Take 0.2 g of this item and take 5 mL of aqua regia in a platinum, quartz or porcelain crucible, and heat it until white smoke is generated. After cooling, water is carefully added to make 5 mL, and this solution is used as the test solution.
Sodium Copper Chlorophyllin	0.5 g of this item and 0.3 g of anhydrous sodium carbonate are placed in a porcelain crucible. 1 mL of bromine-bromide solution is added, shaken well and evaporated to dryness in a water bath. After cooling, add both 2 mL of bromine-hydrochloric acid solution and water to the residue to make 10 mL, and take 5 mL of this solution as test solution.
Calcium 5'-Ribonucleotide, 5'-Cytidylic Acid, 5'-Adenylic Acid, Calcium Phosphate, Tribasic, Magnesium Phosphate, Dibasic, Calcium Phosphate, Dibasic, Calcium Phosphate, Monobasic, Magnesium Carbonate, Calcium Carbonate	Dissolve 0.25 g of this item to the 5 mL of hydrochloric acid, and use it as a test solution.
Sodium metabisulfite	Weigh 0.25 g of this item accurately and put it in a 150 mL beaker. Add 10 mL of water, and add 10 mL of nitric acid and 5 mL of sulfuric acid carefully. Evaporate to 5 mL in a water bath, and heat on a soleplate until white smoke is generated. After cooling, use 10 mL of water to wash the wall of the beaker carefully, and then heat it on a hot plate and cool it until the white smoke of the sulfuric acid is generated. Wash and flush with water repeatedly. Cool it down again and add more water to make 10 mL. Use this solution as test solution.

Items	Preperation Method
Potassium Metabisulfite, Sodium bisulfite, Sodium sulfite	Weigh 2.5 g of this item and dissolve it in water to make 25 mL. Take 5 mL of this solution, add 1 mL of sulfuric acid in it. And concentrate by evaporation to approximately 2 mL, add more water to make 10 mL, and take 5 mL of this solution as test solution.
Sodium Methoxide	Dissolve 5 g of this item in water, which was boiled and cool downed, to make 100 mL. Slowly add hydrochloric acid(1→4) to 5 mL of the test solution, neutralize, evaporate to dryness in a water bath. Add 5 mL of water to the residue, and use this as test solution.
DL-Methionine, L-Methionine	Take 0.5 g of this item to a 500 mL flask for decomposition. Add 5 mL of sulfuric acid and 5 mL of nitric acid to the flask and heated, and add 2~3 mL of nitric acid more and continue heating until the solution becomes pale yellow. After cooling, add 15 mL of saturated ammonium hydroxide solution and heating concentrate until white smoke is generated and make it to 2~3 mL. After cooling, add water to make 10 mL, use 5 mL of this solution as test solution.
Morpholine Salts of Fatty Acids	Add 5 mL of dilute sulfuric acid to 0.25 g of Potassium Sorbate. The mixture is heated in a water bath for 30 minutes. After cooling, the precipitated fatty acid is extracted with ether and the residue is concentrated by evaporation in a water bath to give a volume of about 5 mL. Use this as test solution.
Kaolin	Add 5 mL of dilute hydrochloric acid to 0.5 g of Calcium Sulfate. Shake for 15 minutes, heat it at 70 °C and cool down it quickly, and filter. Wash the residue with 5 mL of diluted hydrochloric acid and 10 mL of water. Add the washed solution to the filtrate, add water to make 20 mL, and take 10 mL of this solution as test solution.

Items	Preperation Method
Bentonite	Add 10 mL of diluted hydrochloric acid to 0.77 g of this item. Then shake for 15 minutes, heat it at 70 ° C. Cool down rapidly and then filter. Wash the residue with 10 mL of diluted hydrochloric acid and 20 mL of water, and add the washed solution to the filtrate. Then, add water to make 40 mL, and take 20 mL of this solution as test solution.
Dry Formed Vitamin A	Put 1 g of this item to a flask for decomposition, and add 20 mL of nitric acid and the heat it mildly until the contents become a fluid phase. After cooling, add 5 mL of sulfuric acid and heat until white smoke is generated. When the solution still shows brown, cool down and add additional 5 mL of nitric acid. This operation is repeated until the liquid turns from light to pale yellow. After cooling, add 15 mL of saturated ammonium hydroxide solution and heat it again until white smoke is generated. After cooling, add water to make 20 mL, and take 5 mL of this solution as test solution.
Riboflavin	This is tested by Arsenic in Coloring matter Test.
Sodium Saccharin	Put 1.25 g of Sodium DL-Malate in a flask for decomposition. Add 10 mL of nitric acid and 5 mL of sulfuric acid and heated. This operation is repeated until the liquid turns from light to pale yellow and is heated until white smoke is generated. After cooling, add 10 mL of water and 15 mL of saturated ammonium hydroxide solution, and heat again until white smoke is generated. After cooling, add water to make 25 mL, take 5 mL of this solution and use this as the test solution.

Items	Preparation Method
Acid Clay	After drying in advance, 2.5 g is placed in a 250 mL beaker. Add 100 mL of hydrochloric acid (1→25) and mix well. Cover with a watch glass and boil for 15 minutes while stirring to avoid excessive foaming. The hot supernatant was filtered at high flow rate into a 200 mL flask. The residue on the filter paper was rinsed four times with 25 mL of hot hydrochloric acid (1→25), the previous filtrate and the washings were combined and cool down at room temperature. Add hydrochloric acid(1→25) to make 200 mL, and take 20 mL of this solution as test solution.
Sodium Aluminium Phosphate, Acidic, Sodium Aluminium Phosphate, Basic	Add 10 mL of hydrochloric acid(1→2) to dissolve 0.25 g of this item. Add water to make 25 mL, and use this as test solution.
Magnesium Oxide, Magnesium Hydroxide	Add 5 mL of hydrochloric acid(1→4) to dissolve 0.25 g of this item, and use this as test solution.
Calcium Oxide	Add 15 mL of diluted hydrochloric acid to dissolve 0.25 g of this item, and use this as test solution.
Iron Sesquioxide	Add 30 mL of hydrochloric acid (1 → 2) and 1 mL of nitric acid to 1 g of this item. It is dissolved by heating. It is concentrated by evaporation on a water bath to make about 5 mL. Add 15 mL of water and the filter the mixture. The insolubles are washed with hot water three times. Washings are combined and add 50 mL of water in it. Take 25 mL of this solution and add 1 mL of sulfuric acid. Concentrate by evaporatation until white smoke is generated, add 10 mL of sulfurous acid, and evaporate it to about 2 mL. Then add water to make 5 mL, and use this as test solution.
Sodium Sesquicarbonate, Sodium Bicarbonate	Add 4 mL of water to dissolve 0.25 g of this item. Slowly add 2 mL of hydrochloric acid, and use this as test solution.

Items	Preperation Method
Sodium hydroxide	Dissolve 50 g of Potassium Sorbate in water, which was boiled and cooled down, to make 250 mL. Use this as test solution. Add 5 mL of water to 1.3 mL of this test solution, and neutralize by slowly adding hydrochloric acid, and use this solution as test solution.
Sodium Hydroxide Solution	Add water, which was boiled and cooled down, to this item. Calculate from the indicated amount and make up to 20% as sodium hydroxide, and use this as test solution. Add 5 mL of water to 1.3 mL of this test solution, neutralize by slowly adding hydrochloric acid, and use this solution as test solution.
Ammonium hydroxide, Potassium hydroxide	Add 5 mL of water to 0.25 g of this item, add hydrochloric acid and neutralize. Use this as test solution.
Calcium Hydroxide, Ferric Phosphate, Ferric Pyrophosphate, Sodium Ferric Pyrophosphate	Add 5 mL of hydrochloric acid(1→2) to this item, and use this as test solution.
Annatto, Water-Soluble	0.25 g of this item is tested for arsenic in the dye test.
L-Cysteine Monohydrochloride	1 g of this item is placed in a 100 mL flask for decomposition, and 5 mL of sulfuric acid and 5 mL of nitric acid are added and heated. Sometimes, 2-3 mL of nitric acid is added and heating is continued until the solution becomes light to pale yellow. After cooling, add 15 mL of saturated ammonium hydroxide solution and heat to 2 ~ 3 mL until white smoke is generated. After cooling, water is added to make 10 mL, and 5 mL of this solution is taken as test solution.
Cyclodextrin	Add 5 mL of water and 1 mL of sulfuric acid to 1 g of this item. Add 10 mL of sulfuric acid, place in a small beaker. Then heat in a water bath and evaporate to about 2 mL with sulfuric acid. Add water to make 5 mL, and use this as test solution.

Items	Preperation Method
Sodium Silicoaluminate	10 g of this item is placed in a 250 mL beaker. Add 50 mL of 0.5 N hydrochloric acid. Cover with a watch glass and heat slowly until boiling. Subsequently, boil the mixture for 15 minutes, and cooled down. When the insolubles are settled, filter the supernatant with Whatman No.4 filter paper or the equivalent. Wash the insolubles and the beaker with 10 mL of hot water for 4 times and filter through the filter paper. Add water to make 100 mL, and take 2.5 mL of this solution as test solution.
Sodium Nitrite	Dissolve 0.25 g of this item in 5 mL of water. Add 2 mL of hydrochloric acid and evaporate to dryness in a water bath. Add 5 mL of water to the residue to dissolve, and use this solution as test solution.
Chlorine	The residue of the Erlenmeyer flask obtained in the nonvolatile material test is dissolved in 2 mL of aqua regia. Add 250 mL of water, and use this solution as test solution(A). 1 mL of this solution corresponds to 1 g of Cl ₂ . Take 10 mL of test solution(A) and dilute with water to make 100 mL. Take 2.5 mL of this solution as test solution.
Ferric Chloride	0.5 g of this item is dissolved in 20 mL of water, and Add 0.2 g of L-ascorbic and dissolve, and use this as test solution.
Sodium Oleate	Add 30 mL of hot water to 5 g of this item and mix well. After adding 6 mL of sulfuric acid(1→20), remove extracted fatty acid with ether extraction. Add water to residue to make 50 mL. Take 5 mL of it, and use it as test solution.

Items	Preperation Method
Silicon Dioxide	After drying, weigh accurately about 10.0 g, add to a beaker, add 50 mL of 0.5 N hydrochloric acid, cover the watch, and boil for 15 minutes. After cooling, transfer to a 100~150 mL centrifuge tube, centrifuge for 10-15 min. Until the insoluble material sinks, then filter the supernatant with filter paper (Whatman No. 4 or equivalent) and transfer the filtrate to a 100 mL flask. Add 10~15 mL of hot water to the residue, mix and centrifuge, and filter the supernatant and add to the filtrate. This operation is repeated two more times, and then add to the filtrate. Water is added to make 100 mL, and 2.5 mL of the solution is used as test solution.
Titanium Dioxide	Place 10 g of this item in a 250 mL beaker and add 50 mL of hydrochloric acid (1→20). Cover the watch, and heat until boiling. Boil more for 15 minutes and then centrifuged to precipitate insoluble material. Filter the supernatant, and wash the water 3 times with 10 mL of hot water. Filter using the same filter paper, wash the used filter paper with 10~15 mL of hot water, add the washing solution to the filtrate, add water to make 100 mL, and use 7.5 mL of this solution as test solution.
L-Isoleucine	Dissolve 0.25 g of this item in 10 mL of 1 N hydrochloric acid, and use this solution as test solution.
Xylitol	Place 0.25 g of this item is in a 500 mL flask for decomposition. Add 5 mL of nitric acid, and heat the mixture gently. Add 2 to 3 mL of nitric acid and continue heating until the solution becomes light~pale yellow. After cooling, add 15 mL of saturated ammonium hydroxide solution and heat to 2~3 mL until white smoke generated. Neutralize with ammonia water or ammonia solution, and use this as test solution.

Items	Preperation Method
Magnesium L-Lactate, Potassium Sodium L-Tartrate	Place 0.25 g of this item is in a 500 mL flask for decomposition. Add 5 mL of nitric acid, and heat the mixture gently. Add 2 to 3 mL of nitric acid and continue heating until the solution becomes light~pale yellow. After cooling, add 15 mL of saturated ammonium hydroxide solution and heat to 2~3 mL until white smoke generated. Neutralize with ammonia water or ammonia solution, and use this as test solution.
Ferrous Lactate	Dissolve 0.5 g of this solution in water to make 25 mL. Add 1 mL of sulfuric acid and 10 mL of sulfurous acid, and concentrate by evaporation to approximately 2 mL. Add water to make 10 mL. Take 5 mL of this solution as test solution.
Potassium Lactate	Weigh 1.0 g as Potassium Lactate, dissolve in 10 mL of water. Add 1 mL of sulfuric acid and 10 mL of sulfuric acid. Evaporate to 2 mL, and add water to make 10 mL. Take 5 mL of this solution as test solution.
Calcium Lactate	Dissolve 0.5 g of this item in 10 mL of water, add 1 mL of sulfuric acid and 10 mL of sulfuric acid, and concentrate by evaporation to 2 mL. Add water to make 10 mL. Take 5 mL of this solution as test solution.
Magnesium Phosphate, Tribasic	Dissolve 0.25 g of this item in 10 mL of diluted hydrochloric acid, and use this solution as the test solution.
Gelatin	10 g of this item is placed in a flask and 60 mL of hydrochloric acid (1→4) is added. The stopper is sealed and heated to dissolve. About 15 mL of bromine TS is mixed and heated to neutralize with excess ammonia solution. 1.5 g of sodium phosphate are added. Add about 30 mL of the solution and leave it for about 1 hour, then filter and take the precipitated sediment. It is washed 5 times with 10 mL of mixed liquid of 1 volume of ammonia solution and 3 volumes of water. The precipitate is dissolved in hydrochloric acid (1→4) to make exactly 50 mL, and take 5 mL of this solution as test solution.

Items	Preperation Method
Sodium Nitrate, Potassium Nitrate	Dissolve 2.5g of this item in 10 mL of water, add 5 mL of hydrochloric acid, and concentrate by evaporation to make about 2 mL. Then add 50 mL of water. Add 1 mL of sulfuric acid to 5 mL of the solution, heat it until white smoke occurs, cool it down and add 5 mL of water. Use this as the test solution.
Sodium Hydrosulfite	Dissolve 2.5g of this item in 25 mL of water. Add 1 mL of sulfuric acid to 5 mL of the solution. Then concentrate by evaporation to make about 2 mL. Add water to make 10 mL, and use 5 mL of it as test solution.
Karaya Gum, Tannic Acid	Place 0.25 g of this item in flask for decomposition. Add 5 mL of sulfuric acid and 5 mL of nitric acid. Then heat the mixture gently. Add 2~3 mL of nitric acid at a time and continue heating until it becomes light~pale yellow. After cooling, add 15 mL of saturated ammonium hydroxide solution, and concentrate the mixture by heating to 2~3 mL until the white smoke of sulfuric acid is generated. The solution is neutralized with ammonia water or ammonia solution, and use it as test solution.
Sodium Carbonate	Dissolve 0.25 g of this item. in 5 mL of water. Add 1 mL of sulfuric acid slowly. And use this as test solution.
Potassium Carbonate, Anhydrous	Dissolve 1 g of this item in 10 mL of water, and add 2 mL of sulfuric acid slowly. Then add water to make 20 mL and use 5 mL of it as test solution.
Talc	Weigh 0.25 g this item, add 5 mL of hydrochloric acid (1→4) and shake well. Then heat it slowly until it boils. Cool down quickly and filter. Wash the residue with 5 mL of hydrochloric acid (1→4) and then with 10 mL of water. Add the solution to the filtrate, and use this solution as test solution.
DL-Tryptophan, L-Tryptophan	Dissolve 0.25 g of this item in a mixture of 3 mL of 1 N hydrochloric acid and 2 mL of water by heating. Then use this as test solution.

Items	Preperation Method
Perlite	Add 5 mL of diluted hydrochloric acid to the 5 g of this item. And shake for 15 minutes at about 50 °C, heat in a water bath for one hour while adding water by replenishing the evaporated water. Cool down and filter it. Wash the residue on the filter paper with water, combine it with the filtrate. Add water to make 100 mL, and take 2 mL of this to use as test solution.
L-Phenylalanine	Dissolve 0.25 g of this item in 10 mL of 2 N hydrochloric acid, and use it as test solution.
Polydextrose	Place 0.25 g of this item to the digestion flask. Add 5 mL of sulfuric acid and 5 mL of nitric acid . The mixture is heated gently. Add 2~3 mL of nitric acid at a time and continue heating until light~pale yellow occurs. After cooling, add 15 mL of saturated ammonium hydroxide solution and heat to 2~3 mL until dark white smoke appears. Then neutralize it with ammonia water or ammonia solution, and use this solution as test solution.
Ferrous Fumarate	Dissolve 1 g of this item by heating with 10 mL of water and 10 mL of sulfuric acid. After cooling, add 30 mL of water to the solution, which is then filtered through a 100 mL flask. The precipitate is washed with water and the washed solution is combined with the filtrate to make 100 mL. Take 25 mL of the solution and use it as test solution.
Active Carbon	Take 12.5 mL of a test solution and evaporate for drying in a water bath. Add 5 mL of water, 1 mL of sulfuric acid and 10 mL of sulfurous acid, and concentrate by evaporation to about 2 mL in a water bath. Add water to make it 5 mL, and use it as test solution.
Cupric Sulfate	Dissolve 0.25 g of this item in 5 mL of water. Add 2 mL of acetic acid and 1.5 g of potassium iodide, and allows it to stand for 5 minutes. Then, Dissolve by adding 0.2 g of L-ascorbic acid, and use it as test solution.

Items	Preperation Method
Calcium Sulfate	Add 1 mL of Hydrochloric Acid and 30 mL of water to 1 g of this item. Dissolve by heating in a water bath, add water to make 40 mL, and take 10 mL of this solution as the test solution.
Yeast	Place 2 g of this item in a 500 mL flask for decomposition. Add 20 mL of water and 30 mL of nitric acid, and mix well and heat it slowly. After cooling, add 10 mL of sulfuric acid and heat it again adding 2~3 mL of nitric acid as needed until the solution becomes pale yellow. After cooling, add 75 mL of water and 25 mL of saturated ammonium hydroxide solution, and heat it until white smoke of sulfuric acid occurs. After cooling, add about 50 mL of water, and neutralize with ammonia water or ammonia solution while cooling. If necessary, evaporate it to less than 100 mL and add water to make exact 100 mL. Take 20 mL of this solution and use it as test solution. However, the standard color of dry yeast is obtained by with 5 mL of arsenic standard solution and 20 mL of the test solution. the standard color of raw yeast is obtained by taking 6 mL of arsenic standard solution and using the same method. The standard color of liquid yeast is obtained by taking 3 mL of arsenic standard solution and using the same method.
Enzymatically Decomposed Apple Extract	Place 0.5 g of this item in a flask for decomposition, and add 5 mL of sulfuric acid and 5 mL of nitric acid. And the mixture is heated gently. Again, add 2~3 mL of nitric acid at a time and continue heating until light~pale yellow appears. After cooling, add 15 mL of saturated ammonium hydroxide solution, and concentrate by heating to 2~3 mL until the white smoke of sulfuric acid is generated. The solution is neutralized with ammonia water or ammonia solution and use it as test solution.

2) Apparatus

The apparatus is depicted in the figure below (unit : mm).

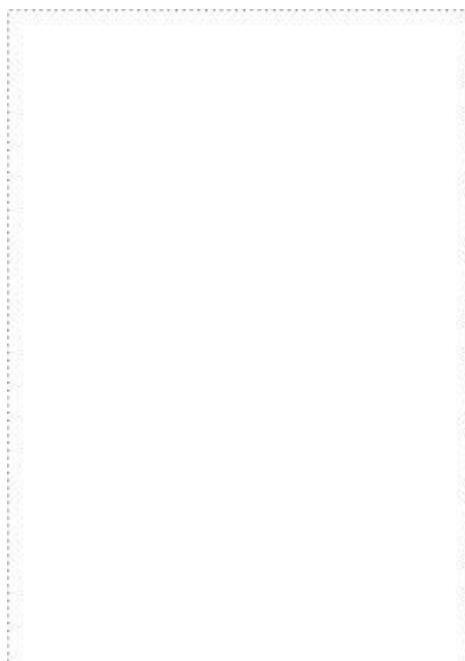

A : approximately 60 mL generator bottle with 40 mL indicating line.

B : glass tube with 6.5 mm inner diameter

C and D : a ground joint glass tube with 6.5 mm inner diameter and 18 mm outer diameter at the joint. Inner joint and the outer joint forms a concentric circle.

E : rubber stopper

F : narrow part of the glass tube B. Glass wool is inserted up to this part.

G : rubber board

H : clamp

The glass tube B is filled with glass wool up to the height of approximately 30 mm from F and soaked uniformly with a 1:1 mixture of water and lead acetate solution. Then, the solution is sucked in from the bottom of the tube. The excess liquid in the wool and the glass wall is removed.

Right before the use of apparatus, a mercuric bromide test paper is inserted in the joint of the glass tubes C and D. Both tubes are secured with a clamp.

3) Procedure

Unless otherwise specified, a required amount of test solution is transferred into the generator bottle and, if necessary, it is neutralized with ammonia water or ammonia solution. Then, 5 mL of diluted hydrochloric acid (1→2) and 5 mL of potassium iodide solution are added, which is set aside for 2 ~ 3 minutes. To this solution, 5 mL of stannous chloride solution is added, which is set aside for 10 minutes. Water is added to bring the total volume to 40 mL, where 2 g of granular zinc. The glass tubes, B, C, and D are inserted into the rubber stopper, which is then placed on the generator bottle. The bottle is immersed (up to approximately 3/4 of its height) in a water bath at 25°C and kept for 1 hour.

4) Preparation of Color Standard

Unless otherwise stated, 1 mL of arsenic standard solution or the amount corresponding to the

specifications is transferred into the generator bottle. The same procedure described above is followed.

5) Arsenic Limit

The procedures in 2) and 3) should be simultaneously followed and at least two sets of apparatus should be used. Right after the test, the mercuric bromide test paper is taken out and the colorimetry is carried out while avoiding direct sunlight. Here, the resulting color in B should not be darker than that in C. If the colors obtained from the same procedure are different, the test should be repeated.

6) Notice on Procedure

- (1) The test solution used in this test or the solution used to make the test solution should not be involved in color reaction at all in the test.
- (2) To ensure that the generated gas does not leak at all, the joints, where the mercuric bromide test paper is inserted, should be kept tight.
- (3) The color of the mercuric bromide test paper fades by the exposure to light, heat and moisture. Therefore, colorimetry should be carried out immediately. The discoloration can be avoided temporarily by storing the paper in a desiccator.

B. Analysis method

1) Preparations of test solution

(1) Wet decomposition method

Place 5~10 g of the sample into a flask for decomposition. Add 50~70 mL of water and 10~40 mL of nitric acid, and mix and leave for a while. Then, after the reaction is done while heating the mixture, cool it down and add 5~20 mL of sulfuric acid and heat it again. When the content starts to boil, add 2~3 mL of nitric acid at a time and continue heating. When the contents become yellow to colorless, it is assumed that the decomposition is finished. After cooling the decomposed solution, add 30~50 mL of water and 10~25 mL of saturated ammonium hydroxide solution, and heat it until white smoke of sulfuric acid occurs. Then cool it down and add water to make it a certain amount and set as a test solution. Perform the same procedure for the blank test solution to correct the test solution. The standard solution is also diluted in the blank test solution described above.

(2) Microwave method

Add 0.5 mL of the sample to a Microwave digestion system, add 7 mL of nitric acid and 1 mL of 30% hydrogen peroxide, and decompose as heating. Transfer it to a volumetric flask or the like and set a certain amount (depending on the amount of sample taken). Or perform the same procedure for the blank test solution to calibrate the test solution. The standard solution is also diluted in the blank test solution described above.

In the case of insoluble materials such as acid clay, kaolin, bentonite, talc, diatomaceous earth and magnesium carbonate, 0.5 g of the sample is precisely weighed and placed carefully so as not to touch the wall of the microwave container made of quartz or tetrafluoromethane. 7 mL of nitric acid, 2 mL of hydrochloric acid, and 1 mL of sulfuric acid are treated and decomposed. After cooling to

room temperature, they are transferred to a volumetric flask, and water is added to make 50 mL. Separately, the same procedure for the black test solution is performed to calibrate the test solution. The standard solution is also diluted in the blank test solution described above.

(3) Solvent extraction method

This test method can be applied to products with high concentrations of inorganic salts.

A) Reagent

(A) MIBK (Methyl isobutyl ketone) or chloroform

(B) Not containing DDTC (diethyl dithiocarbamic acid), silver

B) Test operation

Take 10~50 mL of test solution and blank test solution, respectively in a separatory funnel, add 2~10 mL of 25% ammonium citrate solution and 2 drops of bromothymol blue (BTB) solution. Neutralize with ammonia water until the color of the solution turns from yellow to pale green, and add 2~10 mL of 40% ammonium sulfate TS and water to make a certain amount. Add 1~5 mL of 10% DDTC solution and shake. Add 20 mL of MIBK (or chloroform), shake vigorously and leave it for a while. Take a MIBK (or chloroform) layer. Repeat the above procedure with 20 mL of MIBK (or chloroform) and combine the filtrates. Heat the dispersion to 80 °C on a hot plate, blow off all the solvent, add 7 mL of hydrogen peroxide and 1 mL of hydrogen peroxide to the residue, heat it again on the hot plate, and completely decompose and dry. The residue is redissolved in 1 N nitric acid solution, and use it as test solution. Standard solutions are also obtained by the same procedure.

2) Atomic Absorption Spectrophotometry

A) Arsenic standard solution

Prepare arsenic trioxide(As_2O_3) followed by arsenic standard of V. 4. Standard solution. However, if a commercially available arsenic standard solution is used, it should be converted to arsenic trioxide(As_2O_3).

B) Test operation

After preparing above test solution, follow 18. Atomic Absorption Spectrophotometry.

3) Inductively Coupled Plasma(ICP)

A) Arsenic standard solution

Prepare arsenic trioxide(As_2O_3) followed by arsenic standard of V. 4. Standard solution. However, if a commercially available arsenic standard solution is used, it should be converted to arsenic trioxide(As_2O_3).

B) Test operation

After preparing above test solution, follow 19. Arsenic standard solution(When measuring the mass value of a target element in a salt-rich food additive, the disturbance factor is removed through the reaction gas (NH_3 , O_2 , He, CH_4 gas, etc.) in order to reduce the amount error by the medium.

4) Atomic Absorption Spectrophotometry or Inductively Coupled Plasma(Reduced vaporization method)

A) Analysis Principle

The absorbance and the luminous intensity of the test solution are measured using a reducing gasifier.

B) Reagents and test solution

- ① Potassium iodide(KI)
- ② Sodium borohydride(NaBH_4)
- ③ Sodium hydroxide(NaOH)
- ④ Hydrochloric acid(HCl)
- ⑤ Arsenic standard solution : Prepare arsenic trioxide(As_2O_3) followed by arsenic standard of V. 4. Standard solution. However, if a commercially available arsenic standard solution is used, it should be converted to arsenic trioxide(As_2O_3).

□) Test operation

Dilute the test solution with 1% nitric acid. 3 g of potassium iodide was added to the test solution and the blank test solution, and the mixture was allowed to stand for 1 hour. Then, the test solution and blank test solution, 1: 1 hydrochloric acid, 0.6~1.0% sodium borohydride solution and 0.1~0.5% sodium hydroxide solution were injected into a reductive vaporizer. Then, the absorbance and luminous intensity of arsenic are measured.

9. Boiling Point and Amount of Distillate

Method 1

A. Apparatus

The apparatus is depicted in the figures (1 ~ 4) below (unit : mm).

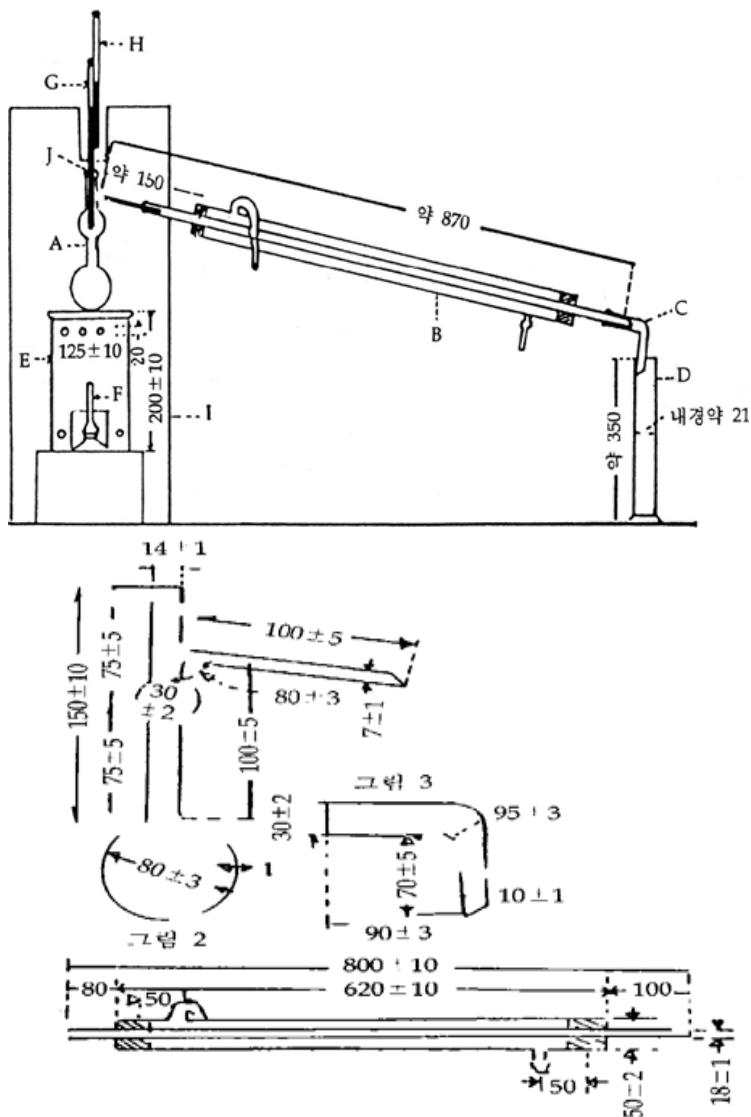

A : Distillation Flask(It is made of hard glass with the capacity of about 300 mL. Refer to figure 2.)

B : Cooling Tube(It is made of hard glass. See the figure 4)

C : Adapter (refer to figure 3)

D : volumetric cylinder (100 mL with 1 mL graduation)

E : Support (It is a metal cylinder with several ventilation holes and it can control the flame of the burner. At the top of the support, two asbestos plates, which are approximately 6 mm thick and

have a 30~40 mm circular hole at the center, are placed.)

F : Burner

G : Thermometer

H : Auxiliary Thermometer (The mercury column should be located at the center of the mercury reservoir.)

I : Wind Protector

J : Cork stopper

Glass apparatus should be completely dried. The end of the adaptor (C) should be in touch the wall of the volumetric cylinder (D). Boiling stone or capillary tube is added to the distillation flask (A). The top of the flask and the separation tube are insulated with asbestos wool.

B. Procedure

With a volumetric cylinder (D), 100 mL of the test solution is measured into a distillation flask (A). This volumetric cylinder does not have to be washed and it can be used as a receiving vessel. Once the apparatus is set up, water is circulated through the cooling tube, the distillation flask is heated, and the distillation is carried out for 10 minutes. Heating is adjusted so that 4 ~ 5 mL of distillate is collected per 1 minute. Unless otherwise specified, the boiling point range is determined such that the lowest is when the fifth drop of the distillate is collected and the highest is when the last drop of liquid evaporates from the bottom of the distillation flask. The correction for the exposed part of the thermometer and atmospheric pressure is done by the following equation.

Correction for the exposed part of the thermometer

$$T_1 = t + 0.00015(t - t_1)n$$

T_1 : corrected temperature of the exposed part of the thermometer

t : temperature of thermometer

t_1 : temperature of auxiliary thermometer

n : number of degrees of mercury column located at the exposed part of the thermometer

Correction for the atmospheric pressure

$$T = T_1 + 0.00012(760 - P)(273 + T_1)$$

T : corrected temperature

P : pressure when the test is carried out

For the distillate that flows out at the temperature of 80°C, the sample is cooled to below 15°C before

the test and 100 mL of the liquid is used as a sample for the test. A piece of paper is cut to fit into the end of the adaptor and used as the cover of the volumetric cylinder, which is immersed in a water bath at 15°C or lower up to the 100 mL mark. Then the amount of distillate is recorded at the same temperature at which the sample is extracted.

Method 2

This method is used to measure the amount of distillate in liquid at distillation temperature of 170°C or lower.

A. Apparatus

The apparatus is depicted in the figures (1 ~ 5) below (unit : mm).

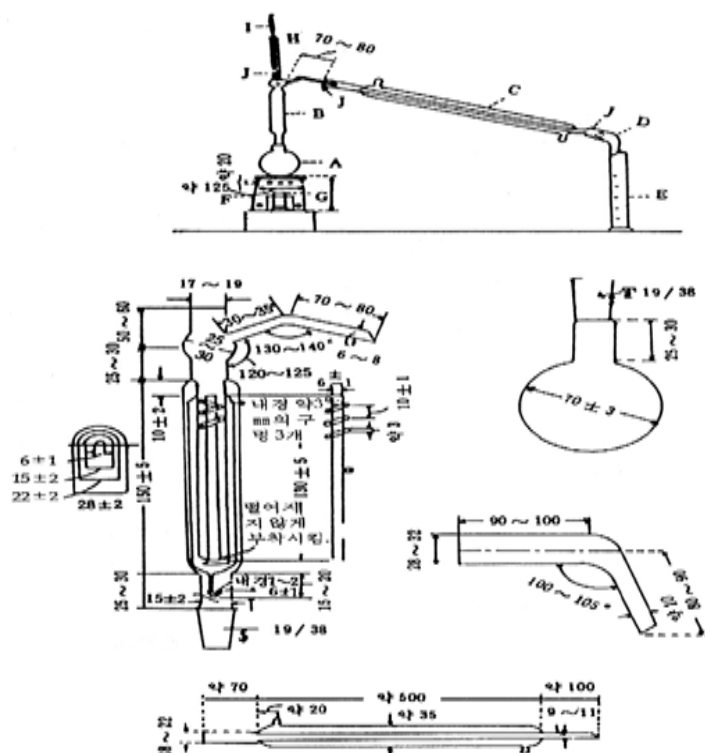

A : Distillation flask (It is made of hard glass with the capacity of about 200 mL. See the figure 2.)

B : Separation tube (It is made of hard glass and about 1 mm thick. See the figure 3)

C : Cooling tube (It is made of hard glass. See the figure 4.)

D : Adapter (It is made of hard glass. See the figure 5.)

E : Volumetric cylinder (100 mL with 1 mL graduation)

F : Support (Same as Method 1)

G : Burner

H : Thermometer

I : Auxiliary thermometer (The mercury column should be located at the center of the mercury reservoir.)

J : Cork stopper

Glass apparatus should be completely dried. The end of the adaptor (D) should be in touch the wall of the volumetric cylinder (E). Boiling stone or capillary tube is added to the distillation flask (A). The distillation flask and the separation tube (B) (except for the side arm) are insulated with glass wool.

B. Procedure

Should follow the procedure in Method 1.

However, the flow rate is kept at 3~4 mL per minute.

10. Specific Gravity

Specific gravity is defined as the ratio of the mass of the sample to the mass of an equal volume of the standard material. In this specification, the specific gravity (d_1^t) means the ratio of the weight of the sample to that of an equal volume of water at $t^\circ\text{C}$ and $t^\circ\text{C}$. Unless otherwise specified, the specific gravity (d) means the ratio of the weight of the sample (d_{20}^{20}) to that of an equal volume of water at 20°C , and is determined by one of the following methods.

A. Measurement by Pycnometer

A pycnometer is a container made of glass with a capacity of usually 10 to 100 mL. It has a ground glass stopper fitted with a thermometer, and has a side tube with a mark and a ground glass cap. A pycnometer is previously washed, dried, and weighed (W). After removing the stopper and the cap, the pycnometer is completely filled with a sample, which is then kept at $1\sim 3^\circ\text{C}$ lower than the specified temperature. The cap is placed while carefully preventing formation of bubbles. The temperature is gradually raised until the thermometer shows the specified temperature. The excess sample above the mark is removed through the side arm, which is then capped and wiped clean on the outside. It is then weighed (W_1). Again, using the same specific gravity bottle, the same procedure is repeated with distilled water. It is then weighed (W_2). Specific gravity (d) is obtained by the following equation.

B. Measurement by Mohr-Westphal Balance

While maintaining the balance horizontal, a glass weight, where a thermometer is inserted, is hung at the right end of the scale bar. The glass weight is immersed in distilled water in a cylinder. The biggest rider is hung at the mark 10, and the balance is leveled by adjusting the screw at a specified temperature. The same procedure is repeated with the sample and the specific gravity is recorded at the position of rider when the balance is leveled. The liquid level should be adjusted so that the length of the metal needle submerged in the liquid is the same as that in distilled water case.

C. Measurement by Hydrometer

A hydrometer with a required precision at a specified temperature is used. The hydrometer is cleaned with alcohol or ether. After well mixing the sample by shaking, the hydrometer is floated after bubbles disappear. At a specified temperature, the specific gravity is recorded from the top of the meniscus when the hydrometer is stationary. However, if the reading directions are provided for the hydrometer, those should be followed.

D. Measurement by Sprengel-Ostwald Pycnometer

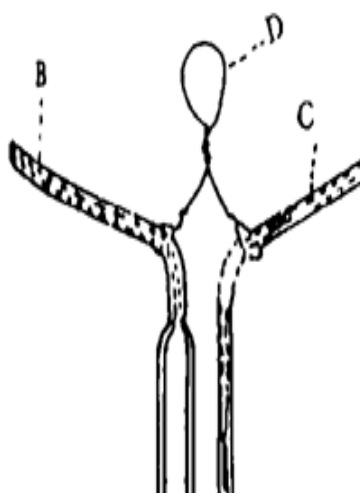

A Sprengel-Ostwald pycnometer is a vessel made of glass with a capacity of usually 1 to 10 mL. As shown in the figure 1, both the ends are thick-walled fine tubes (A), one of which has a mark (C). A platinum or an aluminium wire (D) is hung at this mark. Previously cleaned and dried pycnometer is weighed (W). Another fine tube (B) that has no marks is immersed in the sample, which is kept at a temperature $3 \sim 5^{\circ}\text{C}$ lower than the specified temperature. A rubber tube or a ground fine tube is attached at the end of the other tube (A), and the sample is gently sucked in until it comes up above the mark C, while preventing formation of bubbles. The pycnometer is immersed in a water bath, which is kept at a specified temperature for about 15 minutes. The end of the fine tube (B) is blocked with a piece of filter paper and the sample front is brought up to the mark. Then, the apparatus is removed from the water bath, wiped clean, and weighed (W_1). The same procedure is repeated using the same pycnometer and distilled water (instead of the sample) and it is weighed (W_2). Specific gravity (d) is obtained by the following equation.

11. Optical Specific Rotation

Specific rotation of an optically activated material and its solution are expressed by the equation (1) and (2), respectively. The symbol + and - denote dextrorotatory (right) and levorotatory (left), respectively. The symbol ° is attached to the upper right of a number representing the degree.

.....(1)

.....(2)

α : Corrected angular rotation, in degrees

l : Path length of the liquid (dm)

d : Specific gravity

c : Amount of sample (g) in 100 mL solution

Optical rotation and specific rotation are determined with the specific monochromatic light λ (expressed by wavelength or the name of the light source) at a temperature $t^{\circ}\text{C}$. Unless otherwise specified, it is measured under the conditions of temperature at 20°C , path length of 100 mm, and the D line (589.0 and 589.6 nm) in sodium spectrum

12. Water Determination (Karl Fischer Method)

The determination of water is based upon the quantitative reaction of water with iodine and sulfur dioxide under the presence of pyridine and an methyl alcohol as shown in the reactions below.

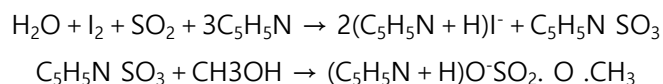

A. Apparatus

It usually consists of two automatic burettes, a titration flask, and a stirrer. If necessary, an electronic device is used to determine the end point. Karl-Fischer solution is highly hygroscopic, therefore, moisture absorption from outside should be prevented. Silica gel, phosphorus pentoxide, or granular calcium chloride is used to prevent moisture absorption.

B. Reagent and Test Solution

- Karl Fischer Methyl Alcohol: Magnesium powder (5 g) is added to 1,000 mL of methyl alcohol, which is heated using a reflux condenser with a calcium chloride tube. If necessary, the reaction is accelerated by adding 0.1 g of mercuric chloride. When the generation of bubbles stops, methyl alcohol is distilled while avoiding introduction of moisture. The amount of moisture is kept at less than 0.5 mg per 1 mL. Moisture should be avoided for storage.

 - Karl Fischer Pyridine: Potassium hydroxide or barium oxide is added to pyridine. The container is capped with a stopper, which is then set aside several days. It is then distilled and the distillate is stored in a moisture free environment. Then distill and store by avoiding atmospheric moisture. The amount of moisture is kept at less than 1 mg per 1 mL. It is stored in a moisture free environment.

 - Karl Fisher solution
- (A) Preparation : Iodine (63 g) is dissolved in 100 mL of Karl-Fischer pyridine, which is cooled in an ice bath. Dry sulfur dioxide passed through until its weight reaches 32.3 g, where Karl-Fischer methyl alcohol is added to bring the total volume to 500 mL. It is then set aside for 24 hours. Since the solution degrades with time, it should be standardized right before use. It should be stored in a dark, moisture-free, and cool place.
- (B) Standardization : 25 mL of Karl Fischer methyl alcohol are transferred into a titration flask, which is heated until the color of the solution changes from yellow to reddish brown. Exactly 50 mg of water is added to this solution, which is heated immediately. While avoiding moisture, the solution is titrated with the Karl Fischer solution to the endpoint, where the same color change occurs as above. 1 milliliter of Karl-Fischer solution corresponds to f mg of water (H₂O).

$$f = \frac{\text{Amount of water(H}_2\text{O)}(\text{mg})}{\text{Volume of Karl-Fischer solution (mL)}}$$

Titrated volume of the Karl Fisher solution(mL)

• Standard solution of water and methyl alcohol

(A) Preparation : Karl Fischer Methyl alcohol (500 mL) is transferred into a 1,000 mL flask, where 2 mL of water and Karl Fischer methyl alcohol are added so that the total amount reaches 1,000 mL. The solution should be standardized right after the standardization of the Karl Fischer solution. It should be stored in a dark, moisture-free, and cool place with a small temperature variation.

(B) Standardization : As described in (5), 20 mL of Water-Methyl Alcohol Solution are transferred into a titration flask and titrated with the Karl Fischer solution until the color of the solution changes from yellow to reddish brown. One milliliter of Water-Methyl Alcohol Solution corresponds to f' mg of water (H_2O).

$$f' = \frac{f \times \text{Titrated volume of the Karl Fisher solution(mL)}}{\text{Volume of standardization(mL)}}$$

In principle, the titration using Karl Fischer solution should be carried out at the same temperature as its standardization temperature. If the sample is not colored, the endpoint can be determined visually. In this case, the point, where the solution becomes reddish brown changing from yellow (vice versa in case of back titration) in color, is the endpoint. If the sample is colored, the endpoint is determined electrically (Dend Stop End Point Method). In this case, two platinum electrodes are immersed in the solution to be titrated, and a constant current (5 ~ 10 μA) is applied to the solution using a variable resistor. Then Karl Fischer solution is drop-wise added. As the titration proceeds, the needle of the microammeter starts to swing vigorously and after a few seconds it comes back to its starting position. When the titration reaches the endpoint, the microampere meter swings even more vigorously (50 ~ 150 μA) for 30 seconds or longer. At this point, the titration is considered to be at the endpoint. In case of back titration, the needle of the microampere meter immediately returns back to its starting position at the end point under the presence of excess amount of Karl-Fischer solution. An apparatus with the Magic Eye can be used in replace of microampere meter. Unless otherwise directed, the titration with the Karl Fischer solution can be carried out by one of the following two methods. Normally, back titration is preferable in case of electrical method. The f of the Karl Fischer solution decreases with time. Precisely 20 mL of Water-Methyl Alcohol standard solution is titrated by following the standardization procedure of Water-Methyl Alcohol standard solution and f is obtained by the following equation.

$$f = \frac{f' \times \text{Volume of standardization(mL)}}{\text{Titrated volume of the Karl Fisher solution(mL)}}$$

(A) Direct Titration : Karl Fischer Methyl alcohol (25 mL) is placed in a dried titration flask, which is then titrated with the Karl Fischer solution to the endpoint. A precisely measured amount (preferably containing 10 to 50 mg of water) of sample is quickly transferred into the titration flask, which is stirred vigorously and then titrated again to the end point.

$$\text{Water content(\%)} = \frac{\text{Titrated volume of the Karl Fisher solution(mL)} \times f}{\text{sample(mg)}} \times 100$$

(B) Back Titration : Approximately 20 mL of Karl Fischer methyl alcohol is placed in a titration flask, where an excess amount of Karl Fischer solution is added to the end point while stirring vigorously. to the endpoint. A precisely measured amount (preferably containing 10 to 50 mg of water) of sample is quickly transferred into the titration flask, which is stirred vigorously with an excess amount of Karl-Fischer solution and then titrated with water-methyl alcohol standard solution to the end point.

$$\text{Water content (\%)} = \frac{(\text{Titrated volume of the Karl Fisher solution(mL)} \times f) - (\text{Volume of standardization(mL)}) \times f}{\text{sample(mg)}} \times 100$$

13. Paper Chromatography

Method 1

A. Apparatus



The apparatus is depicted in the figures below (unit : mm).

A : cylindrical glass vessel

B : chromatography filter

C : position of reference solution

D : position of test solution

E : developing solvent

F : rubber or glass stopper

B. Procedure

With a pencil, a straight line is drawn at approximately 40 mm from the bottom edge of the chromatography paper (B). On this line, a specified amount of the test solution and the reference solution are spotted with a micro pipette or a capillary and dried, where these solutions are prepared as specified for each item. The spots should be approximately 25 mm apart from each other. Using a thread or needle, the filter paper is hung vertically on the stopper (F) in a cylindrical glass vessel

(A) that contains a specified developing solvent (E) without touching the wall of the vessel.

The filter paper is immersed approximately up to 10 mm from bottom edge in the solvent. The vessel is sealed and set aside. When the solvent front reaches a specified distance from the spots, the paper

is removed from the vessel and dried. The positions and colors of the developed spots from the test and reference solutions are observed under natural sunlight and then UV light. If necessary, it is colorized by the specified method.

Method 2

A. Apparatus



The apparatus is depicted in the figures below (unit : mm).

A : circular chromatography paper (diameter 120~130 mm)

B : cylindrical filter paper (Thimble Filter)

C : developing solvent

D : petridish

E : glass hermetical container

F : glass tube

B. Procedure

At the center of a circular chromatography paper (A), a circle with 10 mm radius is drawn with a pencil. On this line, a specified amount of the test solution and the reference solution are spotted with a micro pipette or a capillary and dried, where these solutions are prepared as specified for each item. The total number of the spots should be 6 ~ 8 and they should be apart at the same interval along the circle. A hole with 5 mm diameter punched out at the center of the chromatography paper, where the cylindrical filter paper (Thimble Filter) (B) is inserted. The circular chromatography paper (A) is placed on top of a petri dish (D) with a developing solvent (C) so that the cylindrical filter paper (Thimble Filter) is submerged into the solvent up to approximately 5 mm from the bottom. It is then set aside in a hermetical container. When the solvent front reaches a specified distance, the chromatography paper is removed from the container and dried in air. The same procedure as in Method 1 is followed.

Method 3

A. Apparatus



The apparatus is depicted in the figures below (unit : mm).

- A : a box made of hard synthetic resin
- B : developing container made of hard resin (50x30x230)
- C : chromatography paper
- D & E : glass plate (70x220)
- F : developing solvent
- G : position for test solution or reference solution
- H : cover

B. Procedure

Chromatography paper is cut to 200 mm width and 400 mm length. A parallel line is drawn with a pencil at 50 mm from the short side. On this line, a specified amount of the test solution and the reference solution are spotted with a micro pipette or a capillary and dried in air. The spots should be approximately 25 mm apart from each other. This paper is sandwiched with two glass plates (D & E) so that the paper is exposed up to 40 mm from the bottom (i.e. 10 mm from the line is covered with glass plate). The glass plates are placed in a container (B) with a specified developing solvent (F), which is then set aside in a hermetical box (A). When the solvent front reaches a specified distance, the paper is removed from the box and dried in air. The same procedure as in Method 1 is followed.

C. R_f

The position of the test solution or the reference solution in Method 1 or 3 is A, and the solvent front is B. The center of the developed spot is C from the test solution or the reference solution. The ratio of fronts (R_f) is obtained from the following equation.

$$R_f = \frac{\text{Distance between AC}}{\text{Distance between AB}}$$

Distance between AB

R_f is a characteristic value for a material under the same conditions such as the developing temperature, the properties of chromatography paper, and the choice of developing solvent.

14. Softening Point Measurement

A. Apparatus

It is depicted in figure 1.



A : iron ball (diameter 9.5 mm, weight 3.5 g)

B : a round brass plate, figure 2 (unit : mm).

C : metallic round support plate (approximately 80 mm× 60 mm× 2 mm), which has a hole (I) at the center for mercury reservoir for a thermometer and 4 fix holes (H) for a round plate around the center hole. The distance between the edge of I and the center of H is 17 mm or less.

D : bottom plate (approximately 80 mm× 60 mm× 2 mm) with 40 convection holes (J).

E : settling plate (approximately 126 mm× 28 mm× 2 mm)

F : thermometer (mercury type)

G : beaker (inner diameter 85 mm or higher, height 127 mm or higher)

H : fix hole in the circular plate (diameter 19 mm)

I : hole for mercury reservoir (diameter 2 mm)

J : convection hole (diameter approximately 4 mm)

K₁ & K₂ : supporting pole

The distance from the bottom of E to the top of B is 80 mm or longer. The distance from the bottom of B to the top of D is 25.4 ± 0.2 mm. The distance from the bottom of D to the bottom of G is 20~30 mm. The center of mercury reservoir of the thermometer (F) should be at the same level of the bottom of B.

B. Procedure

Sample is melted as quickly and at temperature as low as possible. The round plate B is placed on the flat metal plate. The melted sample is placed carefully in the round plate so that bubbles are not formed and cooled. With a slightly heated small knife, the part of the sample that is swollen over the top of the round plate is scraped off. Freshly boiled and cooled water is poured into the beaker (G) (over 90 mm in depth) and the water is kept at 15~35°C. At the center of the sample surface in the round plate, the

iron ball (A) is placed and the plate is inserted into the fixing hole (H). The distance between the top of the round plate and the water surface is kept at 50 ± 2 mm. After 15 ~ 20 minutes, heating is started. The burner flame is adjusted so that it is uniformly distributed from the center to the edge of beaker bottom. In 3 minutes of heating, the rising rate is maintained at $5 \pm 0.5^{\circ}\text{C}$ per minute. The softening point is where the sample softens, gets dropped from the round plate, and finally contact with the bottom plate. For each measurement, 4 round plates are used and at least 2 measurements are done. An average value is obtained.

15. Flame Coloration Test

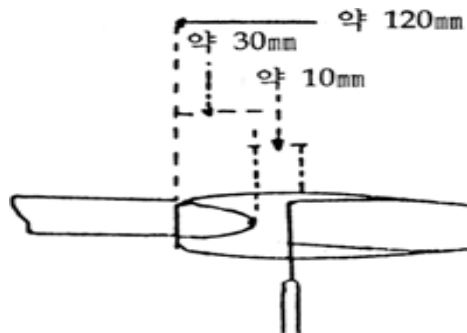

Platinum wire used for this test has a diameter of approximately 0.8 mm. Its straight tip is used as it is. If the sample is solid, a small amount of hydrochloric acid is added to make it into a paste, a small amount of which is stained to approximately 5 mm from the tip of the platinum wire. While keeping the wire horizontal as shown in the figure, it is tested in a colorless flame. If the sample is liquid, the platinum wire is dipped into the sample up to 5 mm from the tip. It is then tested by following the same procedure as the solid sample. When potassium in a sodium salt is tested, the flame is observed using a cobalt glass. Flame color reaction persists approximately for 4 seconds

16. Test Methods for Chloride and Sulfate Salts

This method is used to test the allowed limit of chlorides or sulfates in a sample

A. Chloride Limit Test

Unless otherwise specified, a specified amount of sample is dissolved in approximately 30 mL of water in a Nestler tube. If the solution is alkaline, it is neutralized with dilute nitric acid and then 6 mL of dilute nitric acid is added. It is then diluted with water to 50 mL. If it is specified to use a test solution, it is diluted to 50 mL with dilute nitric acid 6 mL and water in a Nestler tube. In another Nestler tube, a specified amount of 0.01 N hydrochloric acid is added, where 6 mL of nitric acid and water are added to bring the total volume to 50 mL. If the solution is not clear, both solutions are filtered under the same conditions. To both solutions, 1 mL each of silver nitrate solution is added and well mixed. While avoiding the direct sunlight, the mixtures are set aside for 5 minutes. Both tubes are compared in terms of turbidity with a black background.

B. Sulfate Limit Test

Unless otherwise specified, a specified amount of sample is dissolved in approximately 30 mL of water in a Nestler tube. If the solution is alkaline, it is neutralized with dilute hydrochloric acid and then 1 mL of dilute hydrochloric acid is added. It is then diluted with water to 50 mL. If it is specified to use a test solution, it is diluted to 50 mL with water in a Nestler tube. In another Nestler tube, a specified amount of 0.01N sulfuric acid is added, where 1 mL of hydrochloric acid and water are added to bring the total volume to 50 mL. If the solution is not clear, both solutions are filtered under the same conditions. To both solutions, 2 mL each of barium chloride solution is added, well mixed, and set aside 10 minutes. Both tubes are compared in terms of turbidity with a black background.

17. Thermometers

Generally, Needle shape thermometer (stick shape) or mercury thermometer (stick shape) is used after correction. However, for congealing point, melting point, boiling point, and distillation range, Needle shape thermometer (stick shape) is used. Specifications for needle shape thermometer (stick shape) are as follow.

	No.1	No.2	No.3	No.4	No.5	No.6
liquid	mercury	mercury	mercury	mercury	mercury	mercury
filling gas	nitrogen	nitrogen	nitrogen	nitrogen	nitrogen	nitrogen
temperature range	-17 ~ 50°C	40 ~ 100°C	90 ~ 150°C	140 ~ 200°C	190 ~ 250°C	240 ~ 320°C
smallest tick	0.2°C	0.2°C	0.2°C	0.2°C	0.2°C	0.2°C
major tick (per)	1°C	1°C	1°C	1°C	1°C	1°C
tick label (per)	2°C	2°C	2°C	2°C	2°C	2°C
length(mm)	280 ~ 300	280 ~ 300	280 ~ 300	280 ~ 300	280 ~ 300	280 ~ 300
diameter of lower body (mm)	6.0°C±0.1	6.0°C±0.1	6.0°C±0.1	6.0°C±0.1	6.0°C±0.1	6.0°C±0.1
length of mercury reservoir (mm)	12 ~ 15	12 ~ 15	12 ~ 15	12 ~ 15	12 ~ 15	12 ~ 15
distance from the bottom of mercury reservoir to the lowest tick (mm)	75 ~ 90	75 ~ 90	75 ~ 90	75 ~ 90	75 ~ 90	75 ~ 90
distance from the top to the highest tick (mm)	35 ~ 50	35 ~ 50	35 ~ 50	35 ~ 50	35 ~ 50	35 ~ 50
distance from the bottom of mercury reservoir to submerge line (mm)	60	60	60	60	60	60
handle shape	ring	ring	ring	ring	ring	ring
allowed error	0.2°C	0.2°C	0.2°C	0.2°C	0.2°C	0.2°C

18. Atomic Absorption Spectrophotometry

Metal atom is dissociated from a test solution by an appropriate method into an atomic vapor. Use ground state absorbs specific wavelengths from light, using a Spectrophotometric method, an absorbance is measured and from this absorbance a concentration of the target element is obtained. There are two methods in atomizing a metal, Flame Type and Cold Vapor Type.

A. Apparatus

Generally, it consists of light source, atomization part, spectrometer, and photometer. Light source is used a hollow cathode lamp or a discharge lamp. There are two types for an atomization part, Flame Type (direct vaporizer) and Cold Vapor Type. Cold Vapor Type is further divided into reductive evaporation and thermal evaporation. Flame type of atomizer consists of a burner and a gas flow regulator. Reductive evaporator consists of a hermetic container and a pump. Thermal evaporator consists of a quartz dish and a heater. A spectrometer is used a diffraction grid or a prism. Photometer consists of a detector and an indicating instrument.

B. Preparation of Test solution

Unless specified sample weight in the monograph, 5~10g of sample is accurately weighed into crucible or platinum plate, dried, carbonized, and reduced to ash at 450 ~ 550°C. If it isn't reduced to ash, cool it. As ashing supplement, 2~5 mL of nitric acid(1→2) or 50% magnesium nitrate solution or aluminum nitrate . calcium nitrate solution (40 g of aluminum nitrate and 20 of calcium nitrate are dissolved in 100 mL of water) are added, wetted, dried, and continued ashing. If ashing is not enough, repeat above process one time. If necessary, 2~5 mL of nitric acid(1→2) is added and reduced to ash, lastly. After being reduced to ash, the residue is wet with water, and 2~4 mL of hydrochloric acid is added and evaporated to dryness. Specified solvents for each test method (1N hydrochloric acid for tin, 0.5 N nitric acid for other metals) are added, heated, and dissolved. Filter with filter paper if insoluble substances exist. Unless specified solvent, 0.5 N nitric acid is added to make 25mL, test solution. However, for tin, nitrate or nitric acid should not be used as ashing complement. For other metals, they are used only if they don't affect test procedure. Proceed under the same manner for blank test solution to correct test solution.

C. Procedure

Unless otherwise specified, a test solution is prepared by a specified procedure for each item and tested by one of the following methods.

(1) Flame Type

A specified lamp is used as a light source. The lamp is switched on. The spectrometer is adjusted to the specified wavelength to be analyzed and an appropriate current setting is established. A specified mixture of combustible and support gases is ignited. Gas flow rate and pressure are adjusted. Zero point correction is carried out by sparging a solvent into the flame. A test solution prepared by a specified procedure is sprayed into the flame and its absorption is measured.

(2) Cold Vapor Type

A specified lamp is used as a light source. The lamp is switched on. The spectrometer is adjusted to the specified wavelength to be analyzed and an appropriate current setting is established. In case of a reductive evaporator, a test solution is placed in a hermetic container with an appropriate reducing agent and evaporated. In case of a thermal evaporator, a sample is evaporated by heating. Absorption by this atomic vapor is measured.

D. Assay

Usually, one of the following methods is followed. For a quantitative analysis, interference and blank correction (background) should be considered.

(1) Calibration Curve Method

3 or more standard solutions having different concentration are prepared. A calibration curve is prepared from the absorption measurements of these solutions. A test solution having a measurable concentration is prepared and its absorption is measured. The concentration of the target atom is obtained from the calibration curve.

(2) Standard Material Method

Standard solution is incrementally added to a set of (at least 3) test solutions having the same amount. Solvent is added to each solution so that the total volume is identical. Absorption of each solution is measured. Absorption is plotted against the standard element concentration. The concentration of the test element is obtained from the distance between the origin and the intersection between the extrapolated regression line and the horizontal axis. However, this method is only valid when the calibration curve in (1) is a straight line that passes through the origin.

(3) Internal Standard Method

Standard solution is added to a certain amount of internal standard element so that a known amount of standard test element is contained incrementally. Then, solvent is added to each solution so that the total volume is identical. Absorption of each solution is measured. Absorption ratio is plotted against the added standard element concentration. The same amount of internal standard element is added to a test solution. The ratio between absorption by the test element (obtained by the same conditions as in calibration curve) and the internal standard element is obtained. Using this ratio, the concentration of test element is obtained from the calibration curve.

Note : Reagent and Test Solution should not interfere with the measurement.

19. Inductively Coupled Plasma Emission Spectroscopy

A. Apparatus

Generally, it consists of excitation source part, sample injection port, light emission part, spectrometer, photometer, an indication and recording part. Excitation source part is composed of an electric power source, a control system, and circuit to supply and control the electric energy which excites and emits an element in a sample. This part also includes gas supply system and cooling apparatus. The sample injection port is composed of a nebulizer and a spray chamber. The light emission part is composed of a torch tube and a high-frequency induction coil. The spectroscope part is composed of a light-converging system and a spectroscope such as a diffracting grating. The photometry part is composed of a detector and a signal processing system. The indication and recording part is composed of a display and a recording device. The ICP-atomic emission spectrometry includes single-element-sequential-type- and multiple-element-sequential-type-measuring methods using a wavelength scanning spectroscope, and a simultaneously measuring method using a wavelength-fixed-type polychrometer.

B. Preparation of Test Solution

Unless specified sample preparation in the monograph, proceed as directed under preparation of test solution(na) in Atomic Absorption Spectrophotometry.

C. Procedure

Confirm that all live parts are normal. Switch on the excitation source part and the control system. When a vacuum-type spectroscope is used to measure the emission line in vacuum-ultraviolet region, purge sufficiently the light-path between the light emission part and the spectroscope with argon or nitrogen gas for 10 minutes. Set the flow rate for argon or nitrogen gas to the specified rate, switch on the high frequency power supply, and generate the plasma. Correct the wavelength of spectroscope with the emission spectral line of a mercury lamp. Introduce the test solution and the standard solution or control solution prepared as specified in the individual monograph and measure the emission intensity of an appropriate emission line of the object element.

D. Assay

Usually, the determination is done using one of the following methods. In the determination, the interference and blank correction (background) should be corrected.

(1) Calibration Curve Method

Prepare standard solutions of three or more different concentrations, measure the emission intensities of these standard solutions, and prepare a calibration curve from the obtained values. Then, measure the emission intensity for the test solution with a concentration adjusted to a measurable range, and determine the amount(concentration) of the object element from the calibration curve.

(2) Standard Addition Method

To equal volumes of three or more test solutions, add to each the standard solution so that the stepwise increasing amounts of the object element are contained in the solutions, and add the

solvent to make a definite volume. Measure the emission intensity for each solution, and plot the amounts (concentrations) of added standard object element on the abscissa and the emission intensities on the ordinate on the graph. Extend the calibration curve obtained by linking the plots, and determine the amount (concentration) of object element from the distance between the origin and the intersecting point of the calibration curve on the abscissa. This method is applicable only when the calibration curve drawn as directed in section (1) above is a straight line passing through the origin.

(3) Internal Standard Method

Prepare several solutions containing a constant amount of the specified internal standard element, and known graded amounts of the standard object element. For these solutions, measure the emission intensities of the standard object element and internal standard element at the analytical wavelength of each element under the same measuring conditions, and obtain the ratios of each emission intensity of standard object element to the emission intensity of the internal standard element. Prepare a calibration curve by plotting the amounts (concentrations) of standard element on the abscissa and the ratios of emission intensity on the ordinate. Then, prepare the test solutions, adding the same amount of internal standard element as in the standard solution. Proceed under the same conditions as for preparing the calibration curve, obtain the ratio of the emission intensity of standard object element to that of internal standard element, and determine the amount (concentration) of the object element from the calibration curve.

Note : For this test, avoid the use of reagents, test solutions, and gases which interfere with the determination.

20. Mercury Test

Unless specified test in the individual monograph, proceed under one of the following methods.

A. Cold Vapor Atomic Absorption Spectrophotometry

1) Apparatus

- (1) Atomic Absorption Spectrometer : quartz absorption cell is attached
- (2) Lamp : Hollow cathode mercury lamp
- (3) Mercury vapor apparatus

2) Solution

(1) Stannous chloride solution : 10 g of stannous chloride dihydrate ($\text{SnCl}_2 \cdot 2\text{H}_2\text{O}$) is dissolved in 1N sulfuric acid to make 1,000mL.

(2) Mercury standard solution

0.135g of mercury (II) chloride is dissolved in 100 mL of 10% nitric acid and water is added to make 1,000mL. When using, this solution is 1.000 times diluted with 1% nitric acid, standard solution.

Mercury standard solution 1mL = 0.1 μg Hg

3) Preparation of Test solution

Unless specified test in the individual monograph, 5 ~ 10g of sample is transferred into a flask for decomposition. 10 mL of water and 20 mL of nitric acid are added, shaken slowly and 20 mL of sulfuric acid is slowly added. A reflex condenser is attached to the flask, which is boiled until brown smoke is not generated. When the solution doesn't become colorless~light yellow transparent solution, 5 mL of nitric acid is added after cooling, and repeat the process above. After cooling, 50 mL of water and 10 mL of 10% urea solution are added and boiled for 10 minutes. It is cooled, 1 g of potassium permanganate is added, occasionally shaken for 10 minutes, and allow to stand. Repeat this until purple-pink color remains. After boiling for 20 minutes, purple-pink color is discharged, then cool it. 1 g of potassium permanganate is added and heated for 20 minutes again. When purple-pink color of the solution is discharged, repeat 2 times adding and heating of potassium permanganate, and cooled. Add 20 % hydroxylamine hydrochloride solution carefully until the solution becomes colorless and transparent. After cooling, the decomposed solution is transferred to another flask and inside, connecting part of a reflex condenser and a flask for decomposition are washed with water. Rinsing water is added to this, make a certain amount with water, test solution.

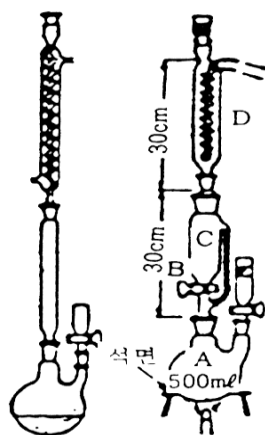

Example of mercury decomposition apparatus

4) Procedure

100 mL each of test solution and blank test solution whose concentration of sulfuric acid is previously adjusted to 20%(v/v) is taken to test solution bottle. After being connected to vapor apparatus, 10 mL of stannous chloride solution is added, and immediately, stopper is placed. Absorbance is measured at 253.7 nm by circulating air in absorption cell using diaphragm pump. Separately, water is added to 1, 5, 10, 15, 20mL each of mercury standard solution to make 100 mL, respectively. Standard solution proceed in the same manner as test solution and calibration curve is prepared by measuring absorbance. Absorbance of test solution is substituted to the calibration curve and the content of mercury is calculated.

B. Gold amalgam Atomic Absorption Spectrophotometry

1) Apparatus

Use mercury measurement apparatus, which automatizes combustion of sample, collection by gold amalgam, and measurement by cold vapor Atomic Absorption Spectrophotometry. Mercury measurement apparatus whose a special catalyst is set on the combustion part, can be used.

2) Reagent and Solution

- (1) Mercury standard stock solution : 0.135g of mercury (II) chloride is dissolved in 0.001% L-cysteine solution to make 1,000mL.

$$\text{Mercury standard stock solution } 1\text{mL} = 100\mu\text{g Hg}$$

- (2) Mercury standard solution : Undiluted mercury standard solution is diluted with 0.001% L-cysteine solution to make 0 ~ 200ng/mL.

- (3) Additives : When using (a) aluminum oxide and (b) calcium hydroxide . sodium carbonate(1:1), activate for 30 minutes at 950°C.

3) Procedure

Approximately 1 g of additive (a) is uniformly spread on ceramic boat and in case of solid sample,

10~300 mg of finely cut and homogenized sample is taken. In case of liquid sample, 0.1~0.5 mL of sample is completely infiltrated into additive (a). On that, about 0.5 g of additive (a) and 1 g of additive (b) are uniformly spread in turn to form the layer. In case of automatic mercury measurement apparatus whose a special catalyst is set on the combustion part, additive is not added to nickel boat and only sample is taken. Boat is transferred into combustion furnace and air or oxygen is flowed about the rate of 0.5 ~ 1 //min. It is heated about 900°C, mercury is spilled, and collected in collection tube. Collection tube is heated about 700°C, mercury vapor is sent to cold vapor Atomic Absorption Spectrophotometry apparatus and absorbance is measured, A. Separately, absorbance is measured in the same manner with additive on ceramic boat, Ab. Separately, calibration curve is prepared from absorbance, which is obtained by same preparation using mercury standard solution. Value of A - Ab is substituted to calibration curve and the content of mercury in sample is calculated.

21. Assay for Alkali Salt of Organic Acid

Unless otherwise specified, sample (corresponding to approximately 0.3 g of sodium) is precisely weighed into a quartz or platinum crucible with 20 ~ 30 mm diameter. It is slowly heated initially, then continuously ramped up, and completely carbonized for approximately 2 hours. The crucible turns dark red at the heating temperature (300~400°C). Care must be taken so that the burner flame should not touch the carbonized material. After cooling, carbonized material is crushed with a glass rod and transferred into a beaker along with the crucible. Approximately 50 mL of water is added to the beaker, where 50 mL of 0.5 N sulfuric acid is added. The beaker is covered with a watch glass and heated for 1 hour in a water bath. The content is filtered. If the filtrate is colored, sample is taken freshly and carbonized sufficiently. Residues on the beaker, crucible, and filter paper are washed well with warm water until the wash water does not turn a blue litmus paper red. The wash water is added to the filtrate. The excess acid is titrated with 0.5 N sodium hydroxide solution (indicator : 3 drops of methyl red solution). A 1 mL equivalent is multiplied to the amount of consumed acid to obtain the amount of salts in the sample.

This method is not to be applied for the alkali salts of organic acids that contains sulfur or halogens.

22. Melting Point

Melting Point means the temperature at which or within the range of which a solid completely melts and is determined by an appropriate one of the methods given below. For convenience of measurement, solids are classified into the following two types

Class 1 substances : easily powdered material

Class 2 substances : fat, fatty acids, paraffin, a material that is very difficult to be powdered

A. Procedure for Class 1 Substances

(1) Apparatus



The apparatus is depicted in the figures below (unit : mm).

A : Round bottom flask for melting point measurement

B : Following solutions are used.

Measurement for 220°C or below : Cupric sulfate

Measurement for 200 ~ 300°C : Sulfuric acid and potassium sulfate (7:3 in weight) are dissolved by stirring and heating.

C : Thermometer

D : Auxiliary thermometer

E : Capillary (inner diameter approximately 1mm, length 50 ~ 70mm, one end is blocked)

F : Ventilation hole

(2) Procedure

sample is finely ground into powder and, unless otherwise specified, dried for approximately 24 hours in a desiccator (sulfuric acid). It is packed into a capillary (E) up to a thickness of 2.5 ~ 3.5 mm. If it is specified to be tested in a sealed container, the open end is sealed. The capillary is attached to the side of a thermometer so that the sample layer is located at the center of the mercury bulb. The thermometer is placed and fixed at the center of a round bottom flask (A) for melting point measurement with a cork or rubber stopper. An auxiliary thermometer (D) is placed so that the center of its mercury reservoir is located at the middle position between the solution surface and the mercury level of thermometer at the melting point (t). An appropriate thermometer is used depending on the measuring temperature range. When the apparatus is set up, the solution is heated to a temperature that is approximately 10°C lower than the expected melting point. Ramping rate is set to 3°C per minute up to a temperature that is approximately 5°C lower than the expected melting point. Then it is set to 1°C per minute. The temperature, where the contact part between inner wall of the capillary and the sample becomes damp or the sample crumbles, is recorded as the beginning of melting point. The temperature, where the sample melts completely and becomes transparent, is recorded as the end of melting point.

Correction for the exposed part of thermometer is done by the following equation.

$$T = t + 0.00015(t - t')n$$

T : corrected temperature

t : temperature reading by the thermometer

t' : temperature reading by the auxiliary thermometer

t'' : If there is not marks in the thermometer at the solution surface, the temperature is read by inserting externally.

n : degrees in the exposed thermometer part (t - t'')

B. Procedure for Cass 2 Substances

A sample is melted at a lowest possible temperature and it is sucked into a capillary up to approximately 10 mm. This capillary is cooled for approximately 24 hours at 10°C or lower, or for at least 2 hours in an ice bath. The capillary is tied to the thermometer so that the sample is located at center of the mercury reservoir. It is then submerged into a beaker with water so that the top of the sample is approximately 10 mm below the water surface. While stirring continuously, the water is heated at a rate of increase of approximately 1°C per 2 minutes until the temperature reaches a point approximately 5°C below the expected melting point. The melting point is where the sample floats within the capillary.

23. Congealing Point

A. Solid at Room Temperature

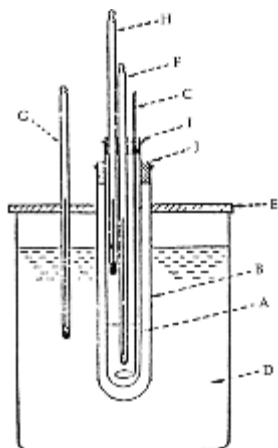

<figure 1 >

(1) Apparatus

The apparatus is outlined in figure 1.

A : Test tube (inner diameter approximately 22 mm, length approximately 160 mm)

B : Large test tube (inner diameter approximately 33 mm, length approximately 150 mm)

C : Stirring pole (diameter approximately 1 ~ 3 mm)

D : Cooling bath, water or ice is used and the temperature is kept at approximately 5°C lower than the congealing point.

E : Wooden cover

F & G : Thermometer

H : Auxiliary thermometer

I & J : Cork stopper

(2) Procedure

Approximately 20 g of sample is placed in a well dried test tube (A), where a thermometer (F) an auxiliary thermometer (H), and a stirring pole (C) are set up using a cork stopper. Mercury bulb of the thermometer (F) is positioned slightly lower than the center of the sample and that of the auxiliary thermometer (H) is positioned at the middle between the surface of the sample and the temperature reading at the congealing point by the thermometer (F). sample in test tube (A) is completely melted in a water or sulfuric acid bath at a temperature that is approximately 10°C higher than the expected congealing point. The melted sample is transferred into a large test tube (B), which is then submerged into a cooling bath (D).It is stirred with a stirring pole at the rate of 1 time for 2 seconds. In the

beginning, the temperature falls slowly. The temperature slightly rises as crystallization starts and remains constant for a while. The temperature reading at this point is corrected for the exposed part of the thermometer by the following equation. This corrected temperature is congealing point.

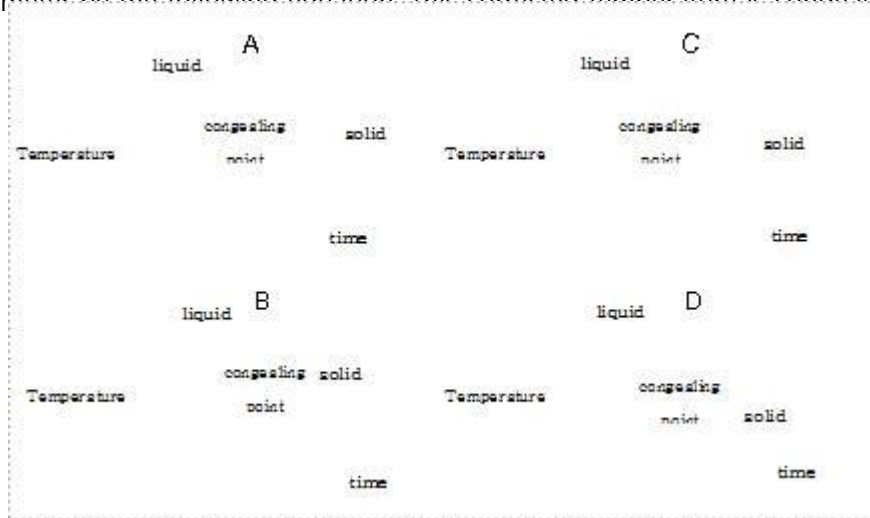

$$T = t + 0.00015(t - t')n$$

T : Corrected temperature

t : Temperature reading by thermometer

t' : Temperature reading by auxiliary thermometer

n : The number of degrees in the exposed part of the thermometer

If there are significant amount of impurities in the sample, the congealing point curve shows a shape as depicted in figure B, C, or D (not figure A). In figure B and D, the intersection of extrapolated lines for solid and liquid phases is the congealing point. In figure C, the method in figure A is followed. In any cases, the correction for the exposed part should be done.

B. Liquid at Room Temperature

(1) Apparatus

The apparatus is outlined in figure 2.

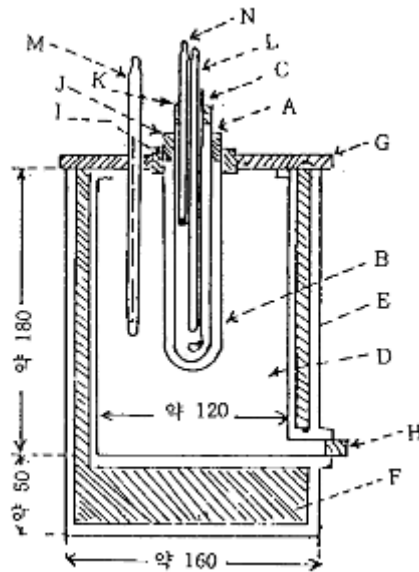

<figure 2>

- A : Test tube (inner diameter approximately 22 mm, length approximately 160 mm)
- B : Large test tube (inner diameter approximately 33 mm, length approximately 160 mm)
- C : Stirring pole (diameter approximately 1 ~ 3 mm)
- D : Cooling bath, water or ice is used and the temperature is kept at approximately 5°C lower than the
congealing point.
- E : Container for cooling bath, metallic container with insulation material (F)
- F : Insulation material
- G : Wooden cover
- H, I, J, & K : Cork stopper
- L & M : Thermometer
- N : Auxiliary thermometer

(2) Procedure

Should follow the same procedure for solid material with approximately 20 mL of sample.

24. Infrared Spectrophotometry

This method is used to qualitatively or quantitatively analyzing a sample based on the fact that a material shows a characteristic absorption pattern depending on its chemical structure in infrared absorption spectrum in a range of $4,000 \sim 667 \text{ cm}^{-1}$. Infrared beam is passed through a sample and an absorption is measured at each wavenumber. A spectrum is plotted as a graph with wavenumbers on the abscissa and transmittance(%) or absorption on ordinate.

A. Apparatus and Procedure

Double beam infrared spectrophotometer is set up in a clean room, where the humidity is kept at 50% and lower and vibration is kept minimal. The ideal room temperature is $20 \sim 25^\circ\text{C}$. The linearity of the absorption should be within $\pm 1\%$ in a transmittance(%) range of $20 \sim 80\%$ and the transmittance(%) is measured twice and its reproducibility should be within $\pm 0.5\%$. The reproducibility of wavenumber should be within $\pm 5 \text{ cm}^{-1}$ near $3,000 \text{ cm}^{-1}$ and within $\pm 1 \text{ cm}^{-1}$ near $1,000 \text{ cm}^{-1}$, respectively. When a polystyrene film (approximately 0.03 m in thickness) is used, it is adjusted so that the absorptions occur at the wave numbers as shown in the following figure.

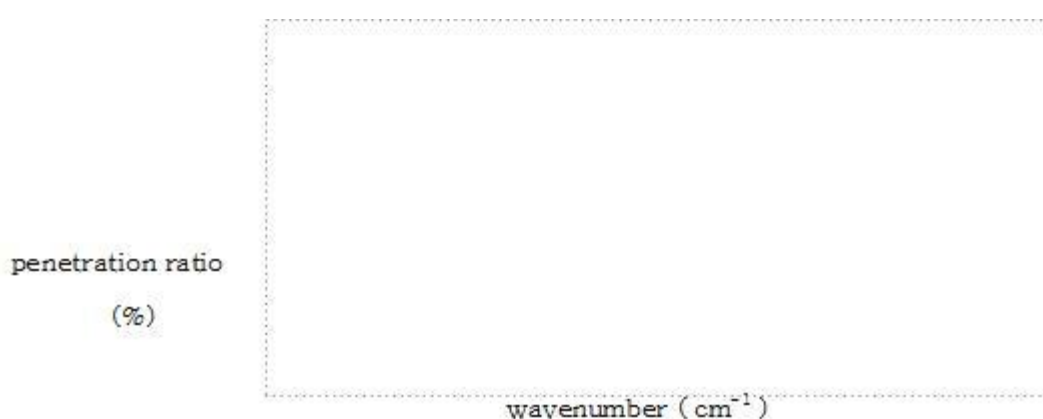

B. Preparation of sample

A sample is prepared so that the transmittance% for the strongest absorption band falls within $20 \sim 80\%$. Sodium chloride, potassium bromide, or potassium bromide iodine (K_2BrI) is used as a window plate material.

(1) Potassium Bromide Disk Method

In a quartz mortar, $1 \sim 2 \text{ mg}$ of solid sample and $100 \sim 200 \text{ mg}$ of potassium bromide (IR spectroscopy grade) are quickly ground and mixed into fine powder while preventing moisture absorption. The mixture is then palletized under a reduced pressure of 5 mmHg using a dry press by applying a pressure of $5 \sim 10 \text{ t/cm}^2$ against the pallet face for $5 \sim 8$ minutes.

(2) Solution Method

Solid or liquid sample is dissolved in a solvent specified for each item. The solution is injected into a liquid cell. The same solvent is injected into a correction cell. The thickness of liquid cell is 0.1 mm or 0.5 mm.

(3) Paste Method

Solid sample is finely ground and mixed with fluid paraffin in a mortar. The paste is inserted between two window plates. Care must be taken so that air is not introduced into the assembly.

(4) Liquid Film Method

Liquid layer, that is formed with 1 ~ 2 drops of liquid sample between two window plates, is measured. If it is necessary to have thicker liquid layer, Aluminum foil is inserted between two window plates to increase the path length.

(5) Thin Film Method

Sample is dissolved in a specified solvent for each item. A window plate is coated with this solution. The solvent is dried off with a heat gun. The remaining thin film of the sample is measured. If the sample is in a form of film with a thickness of 0.02 mm or less, it is measured directly.

(6) Gas Sample Measurement

A gas cell with a path length of 5~10 cm is evacuated and filled with a sample up to a pressure specified for each item. If necessary, a gas cell with 1 m or longer can be used.

25. Viscosity

1. Viscosity measurement by capillary tube viscometer

The unit of viscosity is the Centistokes (cSt) and the viscosity is measured with the following Ubbelohde viscometer or Cannon Ubbelohde viscometer.

A. Apparatus

The apparatus is depicted in the figures below (unit : mm).

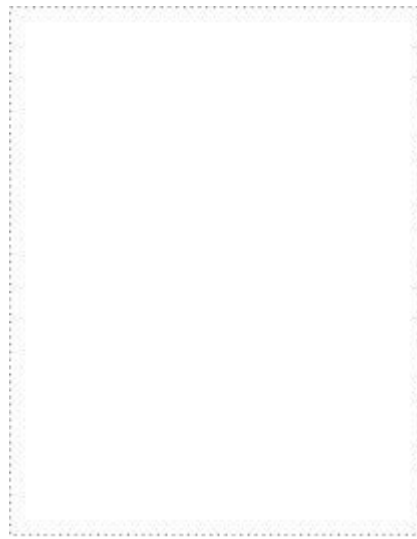

- A, B & C : Tube part
- D, E & F : Spherical part
- G, H, I & J : Marking line
- K : Capillary

The relation between the inside diameter of capillary and the measurable range of the viscosity is as follows.

Inner Diameter	Viscosity Range
0.56~0.60	2~10
0.75~0.79	6~30
0.85~0.89	10~50
1.07~1.13	20~100

1.40~1.46	60~300
1.66~1.67	100~500
1.92~1.98	200~1,000
2.63~2.71	600~3,000
3.01~3.11	1,000~5,000
3.58~3.66	2,000~10,000

B. Procedure

A sample is placed in a tube A, preventing the formation of bubbles in the sample solution. When the viscometer stands vertically, the surface of the liquid sample should be placed in the middle between the marking line G and H of the spherical part D. Then the viscometer is immersed into an isothermal water bath at a specified temperature until the spherical part F of a tube B is fully submerged under water and fixed vertically. It is then set aside for 20 minutes until the temperature of the sample reaches the specified temperature. With the tube C covered with a finger, the sample is sucked in through the tube B until the sample surface reaches the center of spherical part F. Then the tube C is opened and tube B is closed with a finger. When the sample in the lower part of the capillary drops, the tube B is opened and the time (t) taken for the meniscus to move from I to J is measured (in 0.1 seconds). For a set of measurements (2 or more), an average value is obtained and its difference from individual measurement should not be more than 0.1% at 16°C or higher and not be more than 0.5% at 16°C or lower. Viscosity is obtained by the following equation.

$$V = Kt (cSt)$$

where K is the viscometer constant, which is obtained from the same operation with distilled water or a standard solution of which viscosity is already known. The temperature where K is attained may differ from the temperature where the viscosity of the sample is measured. If t is less than 200, a measurement is repeated using a viscometer with a capillary, which has a smaller inner diameter r of the capillary is smaller.

2. Viscosity measurement by rotational viscometer

A. Apparatus

-Viscometer : Model LVP Brookfield or its equivalent (which can measure 25 ~ 10,000 cps at 25°C) is used. It comes with a set of spindles to be used for different range of viscosity.

range(cps)	spindle No.	speed (rpm)	scale	factor
10 ~ 100	1	60	100	1
100 ~ 200	1	30	100	2
200 ~ 1,000	2	30	100	10
1,000 ~ 4,000	3	30	100	40
4,000 ~ 10,000	4	30	100	200

-Stirrer : As shown in figure 1, the stirrer is equipped with a stirring pole and a variable speed controller which can go up to 1,500 rpm.

(Note: AH Thomas Co Catalogue No. 9240-K with a stainless-propeller of 1°C-1/2 inch 3 blade type may be used)

-Container for a sample : A glass container with 13.3 mm in depth, 60 mm in outer diameter and 236 mL in volume is used.

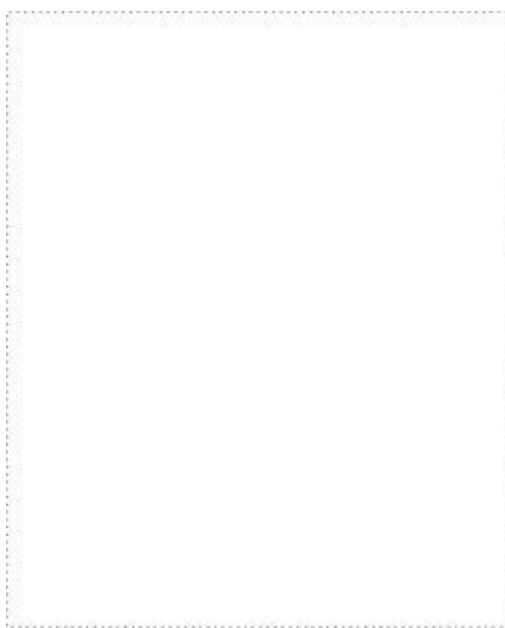

<figure 1>

B. Procedure

4 g of sample (or a specified amount for each item) is placed in the container with a known weight, where water is added to bring the total weight to 400 g. The blade of the stirring pole is positioned in the middle of the liquid, which is stirred at 800 ± 100 rpm. After 1.5 hours, the speed is adjusted appropriately so that air is not introduced and it is stirred for 30 minutes.

After removing the stirring bar, the temperature of the sample is maintained at 25°C in an isothermal water bath of $25 \pm 0.2^\circ\text{C}$, unless otherwise specified. An appropriate spindle and speed are selected

and the spindle is spun until the reading becomes constant. The viscosity is calculated by multiplying the coefficient in the table above with viscosity reading.

26. Heavy Metal Limit Test

This is a method to determine the allowable total limit of metallic impurities contained in a sample by colorizing of a test solution with sodium sulfate solution. The allowed limit of the metallic component is expressed in the equivalent color and indicated in the amount of the lead in the standard reference solution (ppm of sample).

- Lead Standard Stock Solution : After dissolving 159.8 mg of lead nitrate in 10 mL of dilute nitric acid, the solution is diluted to 1000 mL with water. For the preparation and storage of this solution, a glass container that does not contain soluble lead salts should be used
- Lead Standard Solution : 10 mL of lead standard stock solution is diluted to 100 mL with water. This solution is prepared before use and contains 0.01 mg per 1 mL. For example, when 1 g of sample is tested using 1.5 mL of lead standard solution as a reference, the sample contains 15ppm of lead.

Procedure

Unless otherwise specified, a specified amount of sample is placed in a Nestler tube and dissolved in approximately 40 mL of water. The total volume is brought up to 50 mL with 2 mL of dilute acetic acid and water. Separately, an amount of lead standard solution (equivalent to the specified allowed limit) is diluted to 50 mL with 2 mL of dilute acetic acid and water in a Nesler tube. After adding 2 drops each of sodium sulfate solution to each tube, well mixing, and setting aside for 5 minutes, both tubes are observed for color comparison with a white background.

27. Nitrogen Determination

A. Kjeldahl Method

(1) Apparatus

The apparatus is depicted in the figures below (unit : mm).

Ground joints may be used.

A : flask for decomposition (hard glass with 500 ~ 800 mL)

B : glass tube

C : funnel for addition of alkaline solution

D : rubber tube (there is a pinch cork at the connection between
B & C)

E : Wagner tube

F : distillation tube

G : condenser

H : absorption flask (capacity : about 300 mL)

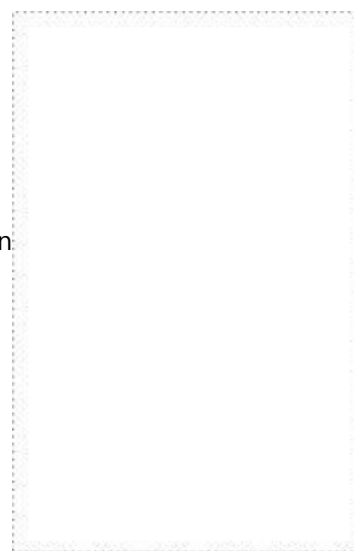

(2) Procedure

Unless otherwise specified, an amount of a sample corresponding to 20 ~ 30 mg of Nitrogen is placed in a flask for decomposition (A), add 5 g of potassium sulfate powder, 0.5 g of cupric sulfate, and 20 mL of sulfuric acid. The flask is tilted at a 45 degree angle, and heated gently until bubbles subside. It is boiled further at a higher temperature until it becomes blue transparent solution. And then boiled for 1 ~ 2 hours. After cooling, 15 mL of water is slowly added to the solution. 2 or 3 granules of boiling chips or granulated zinc are added to the solution and the apparatus is set-up as shown in the figure. 25 mL of 0.1 N sulfuric acid and 50 mL of water are added into the absorption flask (H). The end of the condenser (G) is immersed in the solution. Using a funnel (C), 85 mL of sodium hydroxide solution (2→5) is slowly added and its residue is washed down with a small amount of water. The pinch cork at D is closed and the decomposition flask is gently shaken to mix the content. It is then gently heated to boil and then boiled vigorously until 2/3 of the content is distilled out. The end of the cooling device is removed from the solution surface and its end is washed with water. Distillation is continued for a while. The excess amount of acid is titrated with 0.1 N sodium hydroxide solution (indicator : 3 drops of mixed solution of bromcresol green and methyl red). Separately, a blank test is carried out by the same procedure.

$$0.1 \text{ N sulfuric acid } 1 \text{ mL} = 1.401 \text{ mg N}$$

B. Semi-micro Kjeldahl Method

(1) Apparatus

It is made of hard glass as shown in the figure (units : mm). Ground joints may be used.

- A : flask for decomposition (capacity : about 200 mL)
- B : steam generator (capacity : about 1,000 mL)
- C : Wagner tube
- D : funnel for water
- E : steam tube
- F : funnel for alkaline solution
- G : rubber tube (there is a pinch cork at the connection between E & F)
- H : tube
- I : small hole (inner diameter is almost same as the inner diameter of the tube)
- J : condenser
- K : end of cooling device (tip is angled)
- L : absorption flask (capacity : about 300 mL)



If the apparatus is stored as assembled, Wagner tube (C) and its associated tubes need to be wrapped with asbestos mixed with magnesium carbonate dispersed in water. Decomposition flask (A) needs to be wrapped with cloth or asbestos sheet. Glycerin is applied to the rubber stopper between distillation device and decomposition flask. Rubber stopper and rubber hose are boiled in sodium hydroxide solution for 10 minutes and washed well with water before use. In a steam generator (B), water, 2 ~ 3 drops of sulfuric acid, and boiling stone are added. After use, the absorption flask (L) is washed thoroughly with water and sealed for storage.

(2) Procedure

An amount of sample corresponding to 2 ~ 3 mg of nitrogen is placed in the flask for decomposition (A), where 1 g of the mixture of powdered potassium sulfide and copper sulfide (10:1) is added. If the sample was attached to the neck of the flask, it is flushed it in a minimum amount of water. After slowly adding 7 mL of sulfuric acid along the inner wall of the flask, 1 mL of hydrogen peroxide is carefully added by the same method. The flask is heated on an asbestos net until the content becomes a blue transparent solution and carbonized matter on the inner wall disappears. If decomposition is insufficient, a small amount of hydrogen peroxide is added and cooled. Then it is heat treated again. After cooling, 20 mL of water is carefully added and cooled and the flask is connected to the distillation apparatus, which is previously cleaned with steam. In the absorption flask (L), 15 mL of boric acid

solution (1→25) and 3 drops of mixed solution of bromocresol green methyl red solution are added. An appropriate amount of water is added so that the tip of the cooling tube (K) is submerged into this solution. 30 mL of sodium hydroxide solution (2→5) is added through the funnel (F), which is washed with 10 mL of water. The pinch cork at G is closed and steam is passed through to start distillation. After collecting 80 ~ 100 mL of distillate, the tip of the distillation tube is removed from the solution and the tip is washed with a small amount of water. Water is added to bring the total volume to 157 ~ 180 mL, it is titrated with 0.01 N sulfuric acid. When the solution becomes almost colorless near the end point of titration, 1 drop of the mixture of bromocresol green.methyl red solution is added and further titrated. The end point is where the solution becomes slightly red in color. Separately, a blank test is carried by the same procedure.

$$0.01 \text{ N sulfuric acid } 1 \text{ mL} = 0.1401 \text{ mg N}$$

C. Method using protein analyzer

Reagents and specimens, preparation of test solutions, testing method, and etc. may be changed depending on the type of analyzer.

(1) Devices

- A) Protein decomposition device
- B) Distillation and titration

(2) Operating method

Unless otherwise specified, weighing sample, containing approximately 20~30 mg of nitrogen, precisely, and put it into the decomposition tube and add 2 tablets of decomposition catalyst. 1.4~2.0:1 ratio of Sulfuric acid to potassium sulfate as decomposition catalyst is effective for the decomposition..

Add 12 mL of concentrated sulfuric acid to the decomposition tube, but if the sample has more than 10 % fat, add 15 mL of concentrated sulfuric acid.

Disassemble for 45~60 minutes at 420 °C and cool down to the ordinary temperature if the color of the solution is either clear pale blue(if copper catalyst is used) or transparent yellow(if selenium catalyst is used).

After cooling down, add 80 mL of distilled water to the solution carefully.

Add collected solution, which is mixed with 25 mL of mixed indicator, in a triangular flask, and place it in the distillation device and lift up the flask base. when distilled, the distillate is put into the clathrate solution. Add 50 mL of sodium hydroxide solution(2→5)(the amount is 4 times bigger than the amount of sulfuric acid used as decomposition) to the decomposition tube. Distill it for 3~4 minutes in the distillation device. The collected solution in the triangular flask of distillation device is capturing the alkali(ammonia) in the distillation solution and turns to green.

Titrate until a pale pink color is reached with hydrochloric acid solution(typically 0.1N or 0.2N).

Record the amount of acid used for titration.

In the case of an automatic unit, all the distillation, titration and calculation process are performed automatically.

(3) Calculation

$$\text{Nitrogen(\%)} = \frac{(\text{Consumed HCl (mL)} - \text{Blank test (mL)}) \times M \times 14.01}{\text{sample (mg)}} \times 100$$

14.01 : Atomic amount of nitrogen

M : Molecular concentration of HCl

Decomposition catalyst : Kjeltabs or equivalent

Boric acid solution : 100 g(or 400 g) of H_3BO_3 , 100 mL of 0.1 % bromocreszoline solution, and 1 %(or 4 %) of boronic acid solution where 100 mL of 0.1% methyl red solution is added to make 10 mL

28. pH Determination

pH is measured with a pH meter using a glass electrode.

pH represents an activity of hydrogen ion in a solution and is defined by the following equation. In a dilute solution, this value is very close to a natural log of a reciprocal value of hydrogen ion concentration.

$$pH = pH_s + \frac{E - E_s}{2.3026 RT/F}$$

pH_s : pH value of a pH standard solution

E : Voltage of a battery formed by combination of glass electrode and reference electrode in a test solution. Its constitution is expressed as follows.

Glass electrode | test solution || reference electrode

E_s : Voltage of a battery formed by combination of glass electrode and reference electrode in a pH standard solution. Its constitution is expressed as follows.

Glass electrode | pH standard solution || reference electrode

R : Gas constant

T : Absolute temperature

F : Faraday constant

Values of $2.3026 RT/F$ at various temperature is listed in the table below.

Temperature	2.3026 RT/F	Temperature	2.3026 RT/F
5°C	0.05519	35°C	0.06114
10°C	0.05618	40°C	0.06213
15°C	0.05717	45°C	0.06313
20°C	0.05817	50°C	0.06412
25°C	0.05916	55°C	0.06511
30°C	0.06015	60°C	0.06610

• **Preparation of pH standard solution** : pH standard solution is used as a standard for pH. Water used in pH standard solution is prepared by the following procedure. Purified water is distilled. Distillate is boiled for at least 15 minutes to remove carbon dioxide. It is cooled with a carbon dioxide absorption tube (sodium carbonate). pH standard solution is stored in a hard glass or polyethylene bottle. Extended storage may cause change in pH. Acidic pH standard solution should be used in 3 months and alkaline

pH solution should be stored with a carbon dioxide tube (sodium carbonate) and used in 1 month.

- 1) **Oxalate pH Standard Solution** : Potassium tetra-oxalate (pH measurement grade) is ground into powder and dried in a desiccator (silica gel), 12.71 g (0.05 gram moles) of which is dissolved in water to make 1 L.
- 2) **Phthalate pH Standard Solution** : Potassium hydrogen phthalate (pH measurement grade) is ground into powder and dried at 110°C until the weigh becomes constant, 10.21 g (0.05 gram moles) of which is dissolved in water to make 1 L.
- 3) **Phosphate pH standard solution** : Monopotassium phosphate and Sodium hydrogen phosphate anhydrous (both pH measurement grade) are ground into powder and dried at 110°C until the weigh becomes constant. 3.40 g (0.025 gram moles) of Monopotassium phosphate and 3.55 g (0.025 gram molecule) of sodium hydrogen phosphate are dissolved in water to make 1 L.
- 4) **Borate pH standard solution** : Sodium borate is dried in a desiccator (sodium bromide soaked in water) until the weight becomes constant, 3.81 g (0.01 gram moles) of which is dissolved in water (total volume = 1 L).
- 5) **Carbonate pH standard solution** : 2.10 g (0.02 gram moles) of sodium hydrogen carbonate for pH measurement, which is dried in a desiccator (silica gel) until the weight becomes constant and 2.65 g (0.025 gram moles) of sodium carbonate, which is dried at 300 ~ 500°C until the weight becomes constant are dissolved in water to make 1 L.
- 6) **Calcium hydroxide pH standard solution** : Calcium hydroxide (pH measurement grade) is ground into powder, 5 g of which is placed in a flask. It is mixed and saturated with 1 L of water at 23 ~ 27°C. Supernatant is filtered and the filtrate is used (approximately 0.02 M).

pH values of these standard solutions at various temperatures are shown in the following table. pH values not listed in the table are obtained by interpolation.

Structure of pH meter : A pH meter is generally comprises a detecting part that has a glass electrode and a reference electrode and the indication part that indicates pH corresponding to the detected electromotive force. Indication part has a tap for the regulation of asymmetric electric potential and for the temperature compensation and a tap for the sensitivity regulation. The reproducibility of the pH meter should be within ± 0.05 when pH of pH standard solution is measured 5 times (electrode should be washed well with water after each measurement)

pH Values of pH Standard Solution

Temperature	pH Standard Solution
-------------	----------------------

	oxalate	phthalate	phosphate	borate	carbonate	KOH
0°C	1.67	4.01	6.98	9.46	10.32	13.43
5°C	1.67	4.01	6.95	9.39	10.25	13.21
10°C	1.67	4.00	6.92	9.33	10.18	13.00
15°C	1.67	4.00	6.90	9.27	10.12	12.81
20°C	1.68	4.00	6.88	9.22	10.07	12.63
25°C	1.68	4.01	6.86	9.18	10.02	12.45
30°C	1.69	4.01	6.85	9.14	9.97	12.30
35°C	1.69	4.02	6.84	9.10	9.93	12.14
40°C	1.70	4.03	6.84	9.07		11.99
50°C	1.71	4.06	6.83	9.01		11.70
60°C	1.73	4.10	6.84	8.96		11.45

Procedure : The glass electrode should be kept in water for more than several hours before use. The power of the pH meter should be turned on for at least 5 minutes before use. The detection part is washed with water, which is then is wiped with a filter paper. When a single point correction is performed, the tap for temperature compensation should be matched with the temperature of pH standard solution. Then the detection part is immersed for longer than 2 minutes in the pH standard solution which has the nearest pH value to the pH of test solution. The tap for the regulation of asymmetric electric potential is adjusted so that the pH reading matches with the pH of the standard solution at that temperature.

When a two-point correction is performed, the tap for temperature compensation is matched with the solution temperature. It is immersed in a phosphate pH standard solution that has the nearest pH value to a test solution. The tap for the sensitivity adjustment or the tap for the temperature compensation (regardless of the temperature of the standard solution) is manipulated by the same procedure as described before. After the adjustment, the detection part is washed well with water, which is then is wiped with a filter paper and pH is read.

Note : Detailed structure and Procedure differ with pH meter.

A solution with pH 11 and alkaline metal ions has large errors, so an electrode with a small alkali-related errors should be used (necessary correction should be done).

It is desirable to match the temperature of test solution with that of pH standard solution.

29. Identification

This is used to identify each item. Unless otherwise specified, the concentration of test solution is approximately 1%.

(1) Sodium

(A) When potassium pyroantimonate solution is added to a neutral ~ weakly alkaline solution (1→20) of sodium, white crystalline precipitate is formed (scratching the inner wall of the test tube with a glass rod accelerates the precipitation).

(B) When sodium is tested by the Flame Coloration Test, it shows a yellow color.

(2) Salicylate

(A) When 5 ~ 6 drops of dilute ferric chloride solution is added to a neutral solution of salicylate, the solution becomes purple then colorless.

(B) When dilute hydrochloric acid is added to a salicylate solution (1→20), crystalline precipitate is created. The precipitate is separated, washed with cold water, and dried. The melting point of the precipitate is 158 ~ 161°C.

(3) Benzoate

(A) When a solution of benzoate (1→20) is acidified with dilute hydrochloric acid, crystalline precipitate is formed. The precipitate is separated, washed with cold water, and dried. The melting point of the precipitate is 122°C.

(B) When ferric chloride solution is added to a neutral solution of benzoate (1→20), reddish brown precipitate is produced. When diluted hydrochloric acid is added, white precipitate is separated out.

(4) Calcium

(A) When calcium salt is tested by the Flame Coloration Test, it shows a red color.

(B) When ammonium oxalate solution (1→30) is added to an acid solution of calcium salt with hydrochloric acid, white precipitate is formed. The separated precipitate is insoluble in dilute acetic acid, but it is soluble in dilute hydrochloric acid.

(5) Citrate

(A) When a mixed solution of pyridine:anhydrous acetic acid (3:1) is added to 2 ~ 3 mg of citrate, the color becomes deep red.

(B) Potassium permanganate solution (1/3 volume) is added to an acidic solution of citrate (1→20) with sulfuric acid, which is heated until the color disappears. White precipitate is produced by drop-wise adding bromine solution.

(6) Nitrite

(A) When dilute sulfuric acid is added to nitrite solution (1→20), yellowish brown gas with characteristic smell is generated. If a small amount of crystalline ferrous sulfate is added the solution, it becomes dark brown in color.

(B) When 2 ~ 3 drops of potassium iodide solution is added to a solution of nitrite, where dilute hydrochloric acid is drop-wise added, the solution becomes yellowish brown. Eventually blackish purple precipitate is formed. The solution becomes deep blue when starch solution is added.

(7) Sulfite and Hydrogensulfite

(A) When iodine potassium iodide solution is drop wise added to an acidic solution of sulfite or hydrogen sulfite in acetic acid, the color of the solution is disappears.

(B) When a same amount of dilute hydrochloric acid is added to an acidic solution of sulfite or hydrogen sulfite in acetic acid (1→20), sulfur dioxide (SO₂) smell is generated but the solution doesn't turn turbid (distinct from thiosulfate). When 1 drop of sodium sulfate solution is added, the solution becomes turbid with white color, which gradually becomes yellow precipitate.

(8) Aluminum

(A) When ammonium chloride solution and ammonia solution are added to a solution of aluminum salt (1→20), white gel-like precipitate is produced. The precipitate does not dissolve by adding an excess amount of ammonium solution.

(B) When sodium hydroxide solution is added a solution of aluminum salts (1→20), white gel-like of precipitate is created. The precipitate dissolves by adding an excess amount of sodium hydroxide solution.

(C) When ammonium solution is added to a solution of aluminum salts until a small amount of precipitate is produced, where 5 drops of alizarin S solution (1→1,000) are added. The color of the precipitate changes to red

(9) Ammonium

An excess amount of sodium hydroxide solution is added to ammonium salts. Upon heating, a gas with ammonia odor is generated. This gas turns a red litmus paper (wetted with water) blue.

(10) Chloride

(A) Sulfuric acid and potassium permanganate are added to a solution of chloride salt (1→20). Upon heating, gas with chlorine odor is generated. This gas turns the color of potassium iodine starch paper (wetted with water) to blue.

(B) When silver nitrate solution is added to a chloride solution, white precipitate is created. The precipitate does not dissolve by adding dilute nitric acid, but it does dissolve by adding an excess amount of ammonia solution.

(11) Peroxide

(A) To a 1:1 mixture of ethyl acetate and peroxide solution, 1 ~ 2 drops of potassium bichromate solution is added. When the solution is acidified with dilute sulfuric acid, the aqueous layer becomes blue. When the mixture is shaken and settled to separate, the blue color migrates to the ethyl acetate layer.

(B) When potassium permanganate solution (1→300) is added a solution of peroxide in sulfuric acid, bubbles are created and the color disappears.

(12) Permanganate

- (A) A solution of permanganate has a reddish purple color.
- (B) When an excess amount of hydrogen peroxide is added to an acidic solution of permanganate in sulfuric acid, bubbles are generated and then disappear.
- (C) When an excess amount of oxalic acid solution is added to an acidic solution of permanganate in sulfuric acid, the color of the solution disappears

(13) Potassium

- (A) When potassium salts is tested by the Flame Coloration Test, it shows a light purple color. If the flame is yellow, it shows as reddish purple color through a cobalt glass.

- (B) When sodium hydroxyacetate solution is added to a neutral solution of potassium salt(1→20), white crystalline precipitate is formed. (The scratching on the inner wall of the test tube with a glass rod accelerates the precipitation.) The precipitate separated from the solution dissolves when ammonia solution, sodium hydroxide solution or sodium carbonate solution is added

(14) Glycerophosphate

- (A) When ammonium molybdate solution is added to the solution of glycerophosphate, precipitate is not produced when the solution is cold. Upon boiling for an extended period of time, yellow precipitate is formed.
- (B) Glycerophosphate is mixed with a same amount of potassium hydrogen sulfate powder. When the mixture is gently heated in a direct fire, an irritating odor of acrolein is generated.

(15) Acetate

- (A) When diluted sulfuric acid (1→2) is added to acetate, acetic acid smell is created upon heating.
- (B) When sulfuric acid and a small amount of alcohol are added to acetate and heated, an odor of ethyl acetate is generated.
- (C) When ferric chloride solution is added to a neutral solution of acetate (1→20), it turns reddish brown. Upon heating, it forms reddish brown precipitate. When hydrochloric acid is added, the precipitate dissolves and the solution becomes yellow in color

(16) Bromate

- (A) When 2~3 drops of silver nitrate solution is added to an acidic solution with nitric acid of bromate (1→20), white precipitate is formed, which dissolves by heating. If a drop of sodium nitrite solution is added, light yellow precipitate is produced.
- (B) When 5~6 drops of sodium nitrite solution is added to an acidic solution with nitric acid of bromate (1→20), yellow ~ reddish brown color appears. If 1 mL of chloroform is added and mixed by shaking, chloroform layer shows yellow ~ reddish brown color.

(17) Tartarate

- (A) When silver nitrate solution is added to a neutral solution of tartarate (1→20), white precipitate is formed. If nitric acid is added to the separated precipitate, it dissolves. If ammonia solution is added

to the separated precipitate and heated, it dissolves and forms a silver mirror.

(B) 2 drops of acetic acid, 1 drop of ferrous sulfate solution, and 2 ~ 3 drops of hydrogen peroxide are added to tartrate solution (1→20), where an excess amount potassium hydroxide is added. The mixture turns reddish purple ~ purple.

(C) To 5 mL of sulfuric acid, 2 ~ 3 drops of Resorcin solution (1→50) and 2 ~ 3 drops of potassium bromide are added. This solution is added to 2 ~ 3 drops of tartarate solution (1→20). It is then heated for 5 ~ 10 minutes in a water bath. The solution becomes deep blue in color. When the resulting solution is cooled and mixed with an excess amount of water, it becomes red.

(18) Nitrate

(A) When ferrous sulfate solution is added on top of a cooled mixture (1:1) of nitrate solution and sulfuric acid, a dark brown band is formed at the interface.

(B) When sulfuric acid and copper fragments are added to a nitrate, reddish brown gas is generated.

(C) Even when potassium permanganate solution is added to an acidic solution of nitrate in sulfuric acid, the solution does not decolorizes (distinct from nitrite).

(19) Carbonate

(A) When diluted hydrochloric acid is added to carbonate, bubbles are generated due to formation of gas. If the gas is passed through calcium hydroxide solution, white precipitate is formed. (same as bicarbonate)

(B) When magnesium sulfate solution is added to carbonate solution (1→20), white precipitate is produced. When dilute acetic acid is added, the precipitate dissolves.

(C) A cold solution of carbonate turns deep red by adding phenolphthalein solution. (distinct from bicarbonate)

(20) Bicarbonate

(A) When diluted hydrochloric acid is added to bicarbonate, bubbles are generated due to formation of gas. If the gas is passed through calcium hydroxide solution, white precipitate is created. (same as carbonate)

(B) When magnesium sulfate solution is added to bicarbonate solution (1→20), white precipitate is not created at normal temperature. However, white precipitate is formed upon boiling.

(C) A cold solution of bicarbonate does not turn red by adding phenolphthalein solution. Even if it does get colored, the red color is extremely pale (distinct from carbonate).

(21) Thiocyanate

(A) When excess amount of silver nitrate is added to thiocyanate solution, white precipitate is formed. The precipitate does not dissolve by adding diluted hydrochloric acid, but dissolves by adding aqueous ammonia solution.

(B) When ferric chloride solution is added to thiocyanate solution, it turns scarlet in color and this color does not disappear by adding hydrochloric acid.

(22) Ferrous salt

- (A) When potassium ferricyanide is added to a weakly acidic solution of ferrous salts, blue precipitate is formed. The precipitate does not dissolve when diluted hydrochloric acid or diluted nitric acid is added.
- (B) When sodium hydroxide solution or ammonia solution is added to ferrous salt solution, gel-like white precipitate is formed (If this is well shaken, the color becomes greyish green and gradually turns reddish brown). When sodium sulfide solution is added, the color of precipitate changes to black. When diluted hydrochloric acid is added, the precipitate dissolves

(23) Thiosulfates

- (A) When iodide.potassium iodide is drop-wise added to an acidic solution in acetic acid of thiosulfate, the color of the solution disappears.
- (B) When a same amount of diluted hydrochloric acid is added to thiosulfate solution, sulfur dioxide smell is generated and the solution gradually becomes turbid with white color. When this is set aside, its color is changed to yellow.
- (C) When an excess amount of silver nitrate standard solution is added to thiosulfate solution, white precipitate is formed. If the precipitate is set aside, its color is changed to black.

(24) Ferric salts

- (A) When potassium ferrocyanide is added to a weakly acidic solution of ferric salt, blue precipitate is created. The precipitate does not dissolve when diluted hydrochloric acid or diluted nitric acid is added.
- (B) When Sodium hydroxide solution or ammonia solution is added to ferric salt solution, gel-like reddish brown precipitate is formed. When sodium sulfate solution is added, the color of precipitate changes to black. When diluted hydrochloric acid is added to the separated precipitate, the precipitate dissolves. The solution is turbid with white color.
- (C) If ammonium thiocyanate solution is added to a neutral or weakly acidic solution of ferric salt, deep red color appears. This color persists even by adding hydrochloric acid but disappears by adding mercuric chloride.

(25) Cupric salts

- (A) If a clean iron fragment is placed in an acidic hydrochloric acid solution of cupric salt (with hydrochloric acid), red metal is precipitated from its surface.
- (B) When a small amount ammonia solution is added to cupric salt solution, light blue precipitate is formed. If ammonia standard solution is added to this solution, the precipitate dissolves and its color turns deep blue.
- (C) When potassium ferrocyanide solution is added to cupric salt solution, reddish precipitate is formed. When dilute acetic acid is added to a portion of this solution, the precipitate does not dissolve. When ammonia solution is added to another portion of this solution, the precipitate dissolves and its color turns deep blue.

(26) Lactate

When potassium permanganate solution is added to an acidic sulfuric acid solution (1→20) and heated, acetaldehyde smell is generated.

(27) Magnesium

When ammonium chloride solution and ammonium carbonate solution are added to magnesium salt solution, precipitate is not created. However, if sodium phosphate dibasic is added to the resulting solution, white crystalline precipitate is created. The separated precipitate is insoluble in ammonia solution.

(28) Sulfate

(A) When barium chloride solution is added to sulfate solution, white crystalline precipitate is formed.

The precipitate is insoluble in hydrochloric acid or weak nitric acid.

(B) When Lead acetate solution is added to a neutral solution of sulfate, white precipitate is formed. If ammonium acetate solution is added, the precipitate dissolves.

(C) Even if the same amount of weak hydrochloric acid is added to sulfate solution, it does not become turbid (distinct from thiosulfate). Also, Sulfur dioxide odor is not generated. (distinct from sulfite).

(29) Phosphate (Orthophosphate)

(A) When Silver nitrate solution is added to a neutral solution of phosphate, yellow precipitate is formed.

The precipitate dissolves when diluted nitric acid or ammonia solution is added.

(B) Ammonium molybdate solution is added to a neutral or acidic nitric acid solution of phosphate.

When this solution is heated, yellow precipitate is produced. The precipitate dissolves when sodium hydroxide or ammonia solution is added.

(30) Bromide

(A) When silver nitrate standard solution is added to bromide solution, light yellow precipitate is formed.

The precipitate is hardly soluble in diluted nitric acid or ammonia solution. The precipitate is separated, where ammonia water is added and mixed by shaking. Solution is separated from the precipitate. When the solution is acidified with dilute nitric acid, it becomes turbid with white color.

(B) If chlorine standard solution is added to bromide solution, yellow ~ reddish brown color appears.

When chloroform or carbon disulfide is added to a portion of this solution and mixed, the lower layer has yellow ~ reddish brown color. If phenol is added to another portion of the solution, white precipitate is formed.

(31) Zinc

(A) Under the presence of sodium acetate, zinc salt produces white precipitate by hydrogen sulfide. The precipitate is insoluble in acetic acid, but is soluble in diluted hydrochloric acid. The similar precipitate is created in a neutral or alkaline solution by ammonium sulfide.

(B) When Potassium ferrocyanide is added to zinc salt solution, white precipitate is produced and it is insoluble in diluted hydrochloric acid.

(32) Iodide

When chlorine solution is added to an aqueous solution of iodide, iodide is extricated while changing the color from yellow to red. If chloroform is added to this solution and the mixture is shaken, the chloroform layer shows purple color. If starch standard solution is added to isolated iodine, the solution turns blue. If silver nitrate solution instead of starch standard solution is added, yellow precipitate is formed, which is insoluble in nitric acid and ammonia solution.

(33) Succinic acid salt

Adjust pH of succinic acid salt solution (1→20) to 6-7. To 5mL of the solution, add 1mL of ferric chloride TS. A yellow -red precipitate is formed.

30. Readily Carbonizable Substances Test

This is to test for the allowed limit of impurities in substances, which are easily colored sulfuric acid, when a sample is dissolved in sulfuric acid. Unless otherwise specified, a specified amount of powdered sample is dissolved (small amount at a time) in 5 mL of 94.5%~95.5% of sulfuric acid by mixing with a glass rod in a test tube made of clear hard glass. The solution is set aside for 15 minutes. Separately, color standard solution is placed in a test tube. Both tubes are observed for comparison with a white background. Observation is made from the side and the top. If it is specified that the sample needs to be dissolved by heating, colorimeter test is carried out after heating as specified for the item.

31. Ash and Acid-Insoluble Ash Limit Test

A. Ash

Unless otherwise specified, 3g of sample is placed in a crucible, which is previously dried and weighed, and reduced to ash at 550°C until readily carbonizable substances disappears. It is then cooled in a desiccator and weighed. If carbonization is incomplete, it is wetted with 1 ~ 2 drops water in a cooled crucible. It is dried in a water bath and then reduced to ash again.

B. Acid-Insoluble Ash

To the ash obtained from A, 25 mL of dilute hydrochloric acid is added and the mixture is boiled for 5 minutes. It is then filtered through a quantitative filter paper. The residue is thoroughly washed with boiling water. The filter paper is dried and burned to obtain the amount of ash. The amount of acid-insoluble ash is obtained by subtracting the filter paper ash from the total ash.

32. Spectrophotometry

This method is to measure the degree of absorption of light in a narrow characteristic wavelength range. Absorption spectrum which material solution shows in visible and ultraviolet region depends on the chemical structure of each material.

Therefore, by detecting absorption in various wavelengths, a material can be identified. Usually, absorption of a solution at a certain concentration at max wavelength (λ_{max}) and min wavelength (λ_{min}) is measured, which is then used to Identification, Purity, and Assay test.

When a monochromatic light passes through a solution of a certain material, the ratio of the transmitted light intensity (I) to the incident light intensity (I_0) is called the transmittance (T). Absorbance (A) is the common logarithm of the reciprocal of transmittance.

$$T = \frac{I}{I_0} \qquad A = \log \frac{I_0}{I} = -\log T$$

Absorbance (A) is proportional to the concentration (c) of the solution and the pathlength (l) the layer of of the solution.

$$A = kc / l$$

The absorbance with 1cm (l) and 1% (c) is specific optical density (E), and the absorbance with 1cm (l) and 1M (c) is molecular extinction coefficient (E). Molecular extinction coefficient at the maximum absorption wavelength is E_{max} .

Absorption measurement is carried out with a solution using a specified solvent. It is desirable to have a concentration of a solution so that the absorption within 0.2 ~ 0.7. If the absorption is too high, the solution is diluted to an appropriate concentration.

$$E_{1cm}^{1\%} = \frac{a}{c(\%) \times l}$$

$$E = \frac{a}{c(\text{mol}) \times l}$$

l : path length (cm)

a : absorption from the measurement

$c(\%)$: concentration of test solution (w/v%)

$c(\text{mol})$: concentration of test solution (mol)

A. Apparatus and Preparation

A photoelectric spectrophotometer or photoelectric colorimeter is used as a measuring apparatus. Photoelectric spectrophotometer consists of a monochromator and a photoelectric photometer. A tungsten lamp and a hydrogen discharge lamp are used as light source to measure absorption in visible and UV range, respectively. A photoelectric colorimeter consists of optical filter and photoelectric photometer. A tungsten lamp is used as a light source to measure absorption in visible range. As a cuvette, quartz is used for UV absorption and glass is used for visible absorption.

First, using a specified filter for each method or a filter that has measuring wavelength as a central wavelength, it is adjusted so that a reference solution that lies in a light path gives a zero absorption at a wavelength of spectrophotometer that matches the measuring wavelength. Then a test solution is placed in the light path and an absorption is measured. If possible, a filter with a central transmission wavelength that closely matches with the maximum absorption band of the solution. It is also recommended that wavelength band of the filter transmission is narrower than the absorption band.

In absorption measurement of each additive, "a blank test is carried out to correct" means that a sample is not used as a reference. It rather means that a solution treated by the same procedure as above is used. "A blank test is carried out using a solvent as a reference" means the same solvent to dissolve the sample is used as a reference solvent.

B. Determination Procedure

The equation expressing absorbance (A) is Beer-Lambert's law. This applies to a certain range of concentration of a sample. When absorbance measurement is used as a Assay, this measurable range of concentration should be known. When a standard material is not specified, a pure material of the sample should be used. A set of solutions with various concentrations are prepared and absorbance for each solution is measured. A curve of absorbance vs. concentration is prepared. The linear region of the curve obeys the Beer-Lambert Law and is used as a calibration curve for quantitative analysis.

C. Calibration of Wavelength and Absorbance Scales

Wavelength values are usually examined using quartz mercury lamp or glass mercury lamp at 239.95, 253.65, 302.16, 313.16, 334.15, 365.48, 404.66, 435.83, 546.10 nm and hydrogen discharge lamp at 486.13, 656.28 nm. Absorbance values are examined with a 0.006 w/v% solution of potassium bichromate (standard reagent) in 0.01N sulfuric acid. $E_{1\%}^{1\text{cm}}$ of this solution at 235 (min), 257 (max), 313 (min), and 350 nm (max) are 125.2, 145.6, 48.9, and 107.0, respectively.

33. Coloring Matter Tests

A. Water Insoluble substances

2 g of sample is well mixed in 200 mL of boiling water by shaking and filtered through a crucible type glass filter (1G4) that is previously weighed. Insoluble substances are washed with boiling water until the wash water becomes colorless and dried along with the filter for 3 hours at 135°C. After cooling in a desiccator, the filter with insoluble substances is weighed.

B. Chloride and Sulfate

Precisely 0.1 g of sample is weighed and dissolved in water to make 100 mL, Use this solution as the Test Solution. Separately, 0.165 g of sodium chloride, which is dried at 500 ~ 600°C for 1 hr, is dissolved in water to make 1,000 mL, Standard Stock Solution of chloride ion. Also, precisely 0.148 g of sodium sulfate, which is dried at 100°C for 2 hrs, is dissolved in water to make 1,000 mL, Standard Stock Solution of sulfate ion.

Standard Solutions are prepared by diluting 0.2 mL, 1 mL, 10 mL and 50 mL each of the above Standard Stock Solutions to 100 mL with water. With 20 µl each of Test and Standard Solutions, ion chromatography is carried out under the following operation conditions. A calibration curves are prepared from the peak areas of chloride ions and sulfate ions in each Standard Solution. The content of each ion is obtained from the calibration curve using a peak area of Test Solution. Then the concentrations of sodium chloride and sodium sulfate are obtained by multiplying 1.65 and 1.48 to the amount of chloride ion and sulfate ion. Finally, the contents of sodium chloride and sodium sulfate in the sample are calculated.

Operation Conditions

- Detector : Electrical Conductivity Meter
- Packing material : Porous anion exchange resin
- Column : Stainless steel or plastic tube with inner diameter 2~4 mm, length 20~25 cm
- Eluant : 1.8 mM sodium carbonate solution
1.7 mM sodium carbonate solution
- Flow rate : 1.0~1.5 mL/minute

C. Arsenic

0.5 g of Arsenic is placed in a platinum, quartz, or porcelain crucible. 20 mL of magnesium nitrate in ethyl alcohol (1→50) is added to the crucible and then alcohol is ignited. It is then reduced to ash by heating at 450~550°C. If carbonaceous substance persists, it is wetted with a small amount of nitric acid, which is further heat treated at 450~550°C. After cooling, 6 mL of hydrochloric acid is added to the residue and approximately 10 mL of water is added if necessary, which is then heated in a water bath. After cooling, the solution is brought up to 25 mL with water (Test Solution). When test for arsenic is carried out with this test solution, it should not be more than 4ppm. The color reference is prepared by following the same procedure with 2mL of arsenic standard solution.

D. Heavy Metals

2.5 g of sample is reduced to ash by the same procedure in Residues on Ignition. To the resulting ash, 3 mL of hydrochloric acid and then 7 mL of water are added and mixed. It is then filtered through a quantitative filter paper (Type 5, C). The residues are washed with 5 mL of dilute hydrochloric acid and 5 mL of water, which is added to the filtrate, Solution A. The residues on the filter paper are dried along with the filter paper at 105°C, which is then reduced to ash in a platinum crucible by heating at approximately 450°C. 1~2 g of anhydrous sodium carbonate is added to the crucible, which is then covered and heated to melt the carbonate. After cooling, 10 mL of water is added, which is acidified by drop-wise adding 3 ~ 6 mL of hydrochloric acid. It is transferred into a beaker with a small amount of water, and then water to make 50 mL. Use this solution as the test solution. Separately, a blank test solution is prepared by following the same procedure without the sample.

- (1) Zinc : 2.5 mL of test solution is diluted to 50 mL with 10 mL of diluted hydrochloric acid(1→4) and water, solution B. Separately, 2.5 mL of zinc standard solution, 10 mL of diluted hydrochloric acid(1→4) and water are added to 2.5 mL of blank test solution, which is then diluted to 50 mL, reference solution. For the solution B and the reference solution, proceed as directed under Atomic Absorption Spectrophotometry under the following operating condition. The absorbance of solution B should not be higher than that of reference solution (not more than 200 ppm).

Operation Conditions

Combustible gas : Acetylene

Combustible supporting gas : Air

Lamp : Zinc hollow cathode lamp

Wavelength : 213.9 nm

- (2) Chromium : Unless otherwise specified, 10 mL of test solution is diluted to 50 mL with 10 mL of diluted hydrochloric acid(1→4) and water, solution C. Separately, 10 mL of chromium standard solution, 10 mL of diluted hydrochloric acid(1→4) and water are added to 10 mL of blank test solution, which is then diluted to 50 mL, reference solution. For the solution C and reference solution, proceed as directed under Atomic Absorption Spectrophotometry under the following operating conditions. The absorbance of the solution C should not be higher than that of reference solution (not more than 50 ppm).

Operation Condition

Combustible gas : Acetylene

Combustible supporting gas : Air

Lamp : Chromium hollow cathode lamp

Wavelength : 357.9nm

- (3) Iron : 2 mL of test solution is diluted to 50 mL with 10 mL of diluted hydrochloric acid(1→4) and water, solution D. Separately, 5 mL of iron standard solution, 10 mL of diluted hydrochloric acid(1→4) and water are added to 2 mL of blank test solution, which is then diluted to 50 mL, reference solution.

For the solution C and reference solution, proceed as directed under Atomic Absorption Spectrophotometry under the following operating condition. The absorbance of solution D should not be higher than that of reference solution (not more than 500 ppm).

Operation Condition

Combustible gas : Acetylene

Combustible supporting gas : Air

Lamp : Iron hollow cathode lamp

Wavelength : 248.3nm

(4) Manganese : Unless otherwise specified, 4 mL of test solution is diluted to 50 mL with 10 mL of diluted hydrochloric acid(1→4) and water, solution E. Separately, 1 mL of manganese standard solution, 10 mL of diluted hydrochloric acid(1→4) and water are added to 4 mL of blank test solution, which is then diluted to 50 mL, reference solution. For the solution E and reference solution, proceed as directed under Atomic Absorption Spectrophotometry under the following operating condition, the absorbance of solution E should not be higher than that of reference solution (not more than 50 ppm).

Operation Condition

Combustible gas : Acetylene

Combustible supporting gas : Air

Lamp : Manganese hollow cathode manganese lamp

Wavelength : 279.5nm

(5) Other Heavy Metals : Solution A is diluted to 50 mL with water, 20 mL of the solution is transferred into a Nessler tube. After adding 1 drop of phenolphthalein solution, ammonia solution is added until the solution turns red and 2 mL of acetic acid (1→4) is added. The resulting solution is filtered, if necessary. The filter paper is washed with water and wash water is added to the filtrate. The filtrate is diluted to 50 mL with water, Solution H. Separately, 2.0 mL of lead standard solution and 1 drop of phenolphthalein solution are added to 20 mL of blank test solution, which is treated by the same procedure as the test solution H, Use this solution as the solution I. 2 drops each of sodium sulfate solution are added to Solutions H and I. They are mixed by shaking and set aside for 5 minutes. The color of H should not be deeper than that of I, (Not more than 20ppm).

E. Other Coloring Matters

Ammonium acetate solution is added to 5.0 mL, 2.0 mL and 1.0 mL each of standard stock solution. Each solution is diluted to exactly 100 mL with water, standard solution. Liquid chromatography is carried out with 20 µl each of test and standard solutions under the following operation conditions. Peak area of Subsidiary Colors in test solution is measured. From the calibration curve, the amount of each pigment is obtained. The sum of each pigment is calculated.

Operation Conditions

-Detector: Visible Light Spectrophotometer

-Column: Chemically bonded C18 column with 5 μm (inner diameter 4~6 mm, length 15~30 cm) or its equivalent

-Flow Rate: 1 mL/minute

-Wavelength: 515 nm

-Carrier Phase : A: ammonium acetate solution (7.7 \rightarrow 1,000)

B: acetonitrile : methanol (70:30)

Solution A : Solution B (100:0) \rightarrow Solution A : Solution B (30:70) 25 minutes

F. Unreacted raw materials and products of side reactions

Ammonium acetate solution is added to 5.0 mL, 2.0 mL and 1.0 mL each of standard stock solution. Each solution is diluted to 100 mL with water, standard solution. Liquid chromatography is carried out with 20 μl each of test and standard solutions under the following operation conditions. Peak area of Unreacted raw materials and products of side reactions in test solution is measured. From the calibration curve, the amount is obtained.

Operation Conditions

-Detector : Visible Light Spectrophotometer

-Column : Chemically bonded C18 column with 5 μm (inner diameter 4~6 mm, length 15~30cm) or its equivalent

-Flow Rate : 1 mL/minute

-Wavelength : 290 nm

-Carrier Phase : A : ammonium acetate solution (7.7 \rightarrow 1,000)

B : acetonitrile : methanol (70:30)

Solution A : Solution B(100:0) \rightarrow Solution A : Solution B (30:70) 50 minutes

G. Un sulfonated Primary Aromatic Amines

(1) As Aniline

Accurately 2 g of sample is weighed into a separatory funnel containing 100 mL of water and dissolved by adding 50 mL of water, where 5 mL of sodium hydroxide solution (4 \rightarrow 100) and 50 mL of ethyl acetate are added, shaken well, and extracted. Ethyl acetate layer is separated out. Water layer is further extracted 50 mL of ethyl acetate and the acetate layer is added to the previous extract. It is washed with sodium hydroxide solution (4 \rightarrow 1,000) until the color disappears. The extract is again extracted three times with 10 mL of dilute hydrochloric acid (3 \rightarrow 10). Hydrochloric acid phase are combined and diluted to 100 mL with water, Solution A. After cooling 10 mL of Solution A for 10 minutes in a test tube in an ice bath, 1 mL of potassium bromate solution (1 \rightarrow 2) and 0.05 mL of sodium nitrite solution (1 \rightarrow 30) are added, which is then set aside for 10 minutes in ice.

This mixed solution is transferred into a 25 mL volumetric flask with 1mL of 0.05 mo1/l of 3-hydroxy-2,7-naphthalein sulfonate disodium solution and 10 mL of sodium carbonate solution (1 \rightarrow 10), which is filled with water to 25 mL. It is then set aside for 15 minutes, Test Solution.

Separately, 10 mg of aniline is dissolved in 30 mL of diluted hydrochloric acid (3 \rightarrow 10), which is diluted

to 100 mL with water. 2.0 mL of this solution is further diluted to 100 mL with dilute hydrochloric acid (1→10). This solution is treated by the same procedure as Solution A and its absorption is measured. In case of Test Solution, 10 mL of Solution A is added to 25 mL of volumetric flask, where 1 mL of 0.05 mol/l of 3-hydroxy-2,7-naphthalein sulfonate disodium solution and 10 mL of sodium carbonate solution (1→30). Then water is added to bring the total volume to 25 mL, Reference Solution. Absorption at 510 nm for each solution is measured. Absorbance of the test solution should be less than that of the reference solution.

H. Assay

(1) Titanium Trichloride Method

- (A) A specified amount of test solution is placed in a 500 mL Erlenmeyer flask, where 15 g of sodium citrate and water are added to bring the total volume to approximately 200 mL. While bubbling carbon dioxide through and boiling the solution vigorously, it is titrated with 0.1 N titanium trichloride. The end point is where the characteristic color of the sample disappears
- (B) The same procedure in (A) is followed with 15 g of sodium hydrogen tartarate instead of sodium citrate.
- (C) The same procedure in (A) is followed with 15g of sodium hydrogen tartarate instead of sodium citrate. However, as an indicator, 10 mL of food colorant green No.2 solution (1→1,000) is used. Separately, a blank test is carried out.

(2) Weight Method

A specified amount of test solution is placed in a 500 mL beaker, which is boiled and then cooled. To this solution, 25 mL of dilute hydrochloric acid (1→50) is added, which is boiled again. The inner wall of the beaker is washed with approximately 5 mL of water and the beaker is covered with a watch glass. It is heated for 5 hours in a water bath and cooled in air. The precipitate is filtered through a glass filter (1G4) with a known weight. It is washed 3 times with 10 mL each of dilute hydrochloric acid (1→200) and then twice with 10 mL each of water. The precipitate is dried along with the glass filter for 3 hours at 135°C, cooled in a desiccator, and weighed.

34. Coloring Matter Aluminum Lake Test

A. Hydrochloric Acid- and Ammonia-Insoluble substances

20 mL of water is added to 2 g of sample, where 20 mL of hydrochloric acid is added and mixed well. After adding and mixing with 300 mL of boiling water, it is covered with a watch glass, heated for 30 minutes in a water bath, and cooled. The supernatant is filtered through a glass filter (1G4) with a known weight. The insoluble substances are transferred to the glass filter with approximately 30 mL of water. It is then washed twice with 5 mL each of water. It is again washed with 1% ammonia solution until the wash liquid becomes almost colorless. It is then washed with 10 mL of 1% hydrochloric acid. It is further washed with water until the wash water does not react with silver nitrate solution. It is dried along with the glass filter for 3 hours at 135°C, cooled in a desiccator, and weighed.

B. Arsenic

0.5 g of Arsenic is placed in a platinum, quartz, or porcelain crucible. 20 mL of magnesium nitrate in ethyl alcohol (1→10) is added to the crucible and then alcohol is ignited. It is then reduced to ash by heating at 450~550°C. If carbonaceous substance persists, it is wetted with minute amount of nitric acid, which is further heat treated at 450~550°C. After cooling, 6 mL of hydrochloric acid is added to the residue and approximately 10 mL of water is added if necessary, which is then heated in a water bath. After cooling, the solution is brought up to 25 mL with water (Test Solution). When test for arsenic is carried out with this test solution, it should not be more than 4ppm. The color reference is prepared by following the same procedure with 2 mL of arsenic standard solution.

C. Heavy Metals

2.5 g of sample is reduced to ash by the same procedure in Residues on Ignition. To the resulting ash, 5 mL of hydrochloric acid and 1 mL of nitric acid are added and lumps are crushed. It is evaporated to dryness in a water bath. Again, 5 mL of hydrochloric acid is added to crush the lumps. It is again evaporated to dryness in a water bath. The residues are dissolved by adding 10 mL of dilute hydrochloric acid and heating. After cooling, it is filtered through a quantitative filter paper (Type 5, C). The residues are washed with 30 mL of dilute hydrochloric acid, which is added to the filtrate. The filtrate is evaporated to dryness in a water bath. The residues are dissolved in 10 mL of dilute hydrochloric acid by heating. After cooling, it is filtered. The container and the filter paper are washed with a small amount of water. Wash water is added to the filtrate, where pH is adjusted to approximately 4 using ammonium acetate solution (1→10). It is then diluted to 100 mL with water. Separately, a blank test solution is prepared by following the same procedure without the sample.

(1) Zinc : To 10 mL of test solution, 10 mL of diluted hydrochloric acid(1→4) and water are added to bring the total volume to 50 mL, solution A. Separately, 2.5 mL of zinc standard solution, 10 mL of diluted hydrochloric acid(1→4) and water are added to 10 mL of blank test solution so that the total volume is 50 mL, reference solution. For the solution A and the reference solution, proceed as directed under Atomic Absorption Spectrophotometry under the following operating condition, the

absorbance of solution A should not be higher than that of reference solution (not more than 50 ppm).

Operation Condition

Combustible gas : Acetylene

Combustible supporting gas : Air

Lamp : Zinc hollow cathode lamp

Wavelength : 213.9nm

(2) Iron : 4 mL of test solution is diluted to 50 mL with 10 mL of diluted hydrochloric acid(1→4) and water, solution B. Separately, 5 mL of iron standard solution, 10 mL of diluted hydrochloric acid(1→4) and water are added to 4 mL of blank test solution, which is then diluted to 50 mL, reference solution. For the solution A and the reference solution, proceed as directed under Atomic Absorption Spectrophotometry under the following operation condition, the absorbance of solution B should not be higher than that of reference solution (not more than 250 ppm).

Operation Condition

Combustible gas : Acetylene

Combustible supporting gas : Air

Lamp : Iron hollow cathode lamp

Wavelength : 248.3nm

(3) Other Heavy Metals : 40 mL of test solution is diluted to 50 mL with water, Solution E. Separately, 40 mL of blank test solution, 2 mL of lead standard solution, and water are mixed to have 50 mL of Solution F. When 2 drops each of sodium sulfide solution is added to each Solution E & F, which is then mixed by shaking and set aside for 5 minutes, the color of Solution E should not be deeper than that of Solution F (Not more than 20ppm).

D. Barium

1 g of sample is placed in a platinum crucible, which is reduced to ash by following the procedure in Residues on Ignition. Ash is well mixed with 5g of anhydrous sodium carbonate. The crucible is covered and heated to melt the content. After heating for additional 10 minutes, it is cooled and 20 mL of water is added. The contents are dissolved by heating in a water bath.

After cooling, the solution is filtered and the residues are washed with water until the wash water does not show the reaction of sulfate salts. The residues along with the filter paper are transferred into a beaker, where 30 mL of dilute hydrochloric acid. It is well mixed and boiled. After cooling, it is filtered and the residues are washed with 10 mL of water and the wash water is added to the filtrate. The filtrate is evaporated to dryness in a water bath. The residues are dissolved by adding 5 mL of water, which is then filtered, if necessary. 0.25 mL of dilute hydrochloric acid is added and mixed well. Water is added to the filtrate to bring the total volume to 25 mL, test solution. Separately, 0.5 mL of dilute hydrochloric acid and water are added to 0.5 mL of barium standard solution, which is then diluted to 25 mL, reference solution. Proceed test for the test solution and the reference solution as directed under Inductively

Coupled Plasma Atomic Emission Spectrometry. The emission intensity of test solution should not be higher than that of reference solution (not more than 500 ppm).

E. Assay

- (A) A specified amount of sample is placed in a 500 mL wide-mouth Erlenmeyer flask, where 20 mL of dilute sulfuric acid and then 50 mL of boiling water are added. The sample is dissolved by heating. To this solution, 150 mL of boiling water and then 15g of sodium citrate are added. While bubbling carbon dioxide through and vigorously boiling the solution, it is titrated with 0.1 N titanium trichloride solution. The end point is when the characteristic color of the sample is discharged.
- (B) The same procedure in (A) is followed with 15g of sodium hydrogen tartarate instead of sodium citrate.
- (C) The same procedure in (A) is followed with 15g of sodium hydrogen tartarate instead of sodium citrate. However, as an indicator, 10 mL of food colorant green No.2 solution (1→1,000) is used. Separately, a blank test is carried out.

35. Flavoring Substances Test

A. Halogenated Compounds

- (1) Copper Screen Method : Copper wire, which is used at the end of copper screen of 15 mm width, 5 cm length, approximately 1 mm mesh size, is used. This copper screen is burned in a colorless flame of a burner until green color in the flame disappears and cooled in air. This is repeated several times so that a film of oxide is formed. After cooling, the screen is coated with 3 drops of sample and burned. This is repeated 3 times. When this screen is burned in a colorless outer flame, that is adjusted to approximately 4 cm in height, green colored flame should not appear
- (2) Ignition Method : A quantitative filter paper is cut into a size of 5 cm width and 6 cm length, which is dipped into a sample and placed on a watch glass. The watch glass is placed on a tripod and the filter paper is ignited. Watch glass is immediately covered with a 1l beaker, which is wetted with water. After ignition is finished, the inner wall of the beaker is washed 10 mL of water. 1 drop of nitric acid and then 1 drop of silver nitrate solution are added to the wash water. The resulting turbidity should not be higher than that of a reference solution that is prepared by following the same procedure without a sample.

B. Acid Value

Unless otherwise specified, approximately 10 g of sample is precisely weighed and dissolved (by heating, if necessary) in approximately 50 mL of alcohol (neutralized with 0.1 N potassium hydroxide using phenolphthalein solution) or 1:1 mixture of alcohol and ether. It is titrated with 0.1 N sodium hydroxide solution using a micro-burette until a red color persists for 30 seconds (indicator : 1 mL phenolphthalein solution). If the precipitate of sample is formed, additional solvent is added to dissolve it.

$$\text{Acid Value} = \frac{0.1\text{N NaOH consumption (mL)} \times 5.611}{\text{Sample(g)}}$$

C. Ester Value and Ester Content

Unless otherwise specified, a specified amount of sample is precisely weighed into a 150 mL flask, where 10 mL of alcohol and 3 drops of phenolphthalein solution are added. It is neutralized with 0.1 N potassium hydroxide solution. 25 mL of 0.5 N alcoholic solution of potassium hydroxide is added. A reflux condenser is attached to the flask, which is gently boiled for 1 hour in a water bath. After cooling, 1 mL of phenolphthalein solution is added to the solution and excess alkali is titrated with 0.5 N hydrochloric acid. Separately, a blank test is carried out.

$$\text{Ester Value} = \frac{(a - b) \times 28.05}{\text{Sample(g)}}$$

Sample (g)

The equation for ester content below applies only to the monobasic acid esters.

$$\text{Ester Content(\%)} = \frac{\text{Molecular weight of ester} \times (a - b) \times 0.5}{\text{Sample (g)} \times 1,000} \times 100$$

a : consumed amount of 0.5N hydrochloric acid in blank test (mL)

b : consumed amount of 0.5N hydrochloric acid for test solution (mL)

D. Saponification Value

Unless otherwise specified, a specified amount of sample is precisely weighed into a 150 mL flask, where 25 mL of 0.5 N alcoholic solution of potassium hydroxide. A reflux condenser is attached to the flask, which is gently boiled for 1 hour in a water bath. After cooling, 1 mL of phenolphthalein solution is added to the solution and excess alkali is titrated with 0.5 N hydrochloric acid. Separately, a blank test is carried out.

$$\text{Saponification Value} = \frac{(a - b) \times 28.05}{\text{Sample(g)}}$$

a : consumed amount of 0.5 N hydrochloric acid in blank test (mL)

b : consumed amount of 0.5 N hydrochloric acid for test solution (mL)

E. Phenol Content

Unless otherwise specified, the content of phenol is measured as the content of matters in a sample that are soluble in alkali hydroxides and by the following method.

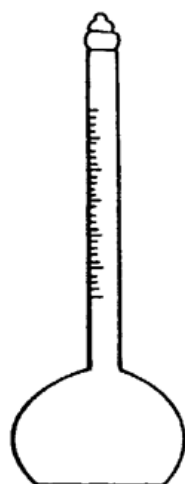

<Cassia flask>

10 mL of sample is placed in 150 mL of Cassia flask, where 75 mL of potassium hydroxide solution is added in 3 portions. It is mixed well by shaking for 5 minutes. It is set aside for 30 minutes, where 1N potassium hydroxide solution is slowly added until the insoluble oil rises up to the graduated marks of the flask. After setting aside for 1 hour, the amount is measured.

$$\text{Phenol Content (\%)} = 10 \times [10 \text{ amount of insoluble oil (mL)}]$$

F. Alcohol Content

Alcohol content is the content of isolated alcohols that are present in a sample.

Procedure

Unless otherwise specified, the following method is followed.

Method 1

In a 100 mL flask with an air condenser, 10 mL of sample, 10 mL of anhydrous acetic acid, and 1 g of anhydrous sodium acetate (freshly melt by heating) are added and gently boiled for 1 hour in a water bath. After setting aside for 15 minutes, 50 mL of water is added, which is heated for 15 minutes in a water bath. After cooling, the contents is transferred into a separatory funnel and the aqueous phase is separated out. Oil phase is washed with sodium carbonate solution until the wash solution becomes basic. It is then washed with sodium chloride solution until the wash solution becomes neutral. This oil phase is transferred into a dried container, where approximately 2 g of anhydrous sodium sulfate is added and mixed well by shaking. It is set aside for 30 minutes and then filtered. A specified amount of acetylated oil is precisely weighed and tested by the following ester value measurement method.

This ester value is also called acetyl value and calculated by the following equation.

$$\text{Acetyl Value} = \frac{(a - b) \times 28.05}{\text{weight of sample}}$$

$$= \text{Acetylated oil(g)}$$

(1) A sample without ester

$$\text{Alcohol Content(\%)} = \frac{\text{Molecular weight of alcohol} \times (a - b) \times 0.5}{[\text{Acetylated oil(g)} - 0.02102(a - b)] \times 1,000} \times 100$$

$$= \frac{\text{Acetyl Value} \times \text{Molecular weight of alcohol}}{561.1 - (0.4204 \times \text{Acetyl Value})}$$

a : consumed amount of 0.5 N hydrochloric acid in blank test (mL)

b : consumed amount of 0.5 N hydrochloric acid for test solution (mL)

Method 2

A specified amount of sample is precisely weighed into a 200 mL flask with a stopper, where 5 mL of anhydrous acetic acid-pyridine solution is added. The connection part is wetted with 2 ~ 3 drops of pyridine and the stopper is loosened. It is then heated for 1 hour in a water bath. After cooling, the inner wall of flask and the stopper are washed with 10 mL of water into the flask. After a stopper is placed, it is mixed by shaking and cooled to normal temperature. The connection part and the inner wall are washed with 5 mL of neutralized alcohol into the flask. It is then titrated with 0.5N alcoholic solution of potassium hydroxide (indicator : 2 ~ 3 drops of cresol red-thymol blue solution). Separately, a blank test is carried out by the same procedure.

$$\text{Alcohol content (\%)} = \frac{\text{Molecular weight of alcohol} \times (a - b) \times 0.5}{\text{Sample (g)} \times 1,000} \times 100$$

a : consumed amount of 0.5 N alcoholic solution of KOH for blank test (mL)

b : consumed amount of 0.5 N alcoholic solution of KOH in a test solution (mL)

G. Aldehydes and Ketones content

(1) Sodium Hydrogen Sulfite Method

Unless otherwise specified, 10 mL of sample is placed in a 150 mL Cassia flask, where 75 mL of sodium hydrogen sulfite solution is added and mixed. It is heated while shaking occasionally in a boiling water

bath until the lump disappears completely. 25 mL of sodium hydrogen sulfite solution is added to the solution, shaken and mixed, which is then set aside for 10 minutes in a boiling water bath. Sodium hydrogen sulfite solution is slowly added until the insoluble oil rises up to the graduated marks of the flask. After setting aside for 1 hour, the amount is measured.

$$\text{Content of aldehydes and ketones (\%)} = 10 \times [10 \text{ amount of insoluble oil (mL)}]$$

(2) Sodium Sulfite Method

Unless otherwise specified, 75 mL of freshly prepared 30% sodium sulfite solution and 2 drops of phenolphthalein solution are added to a 150 mL Cassia flask and isolated alkali is neutralized with acetic acid. 10 mL of sample is added to the flask, which is well shaken in a boiling water bath. Isolated alkali is occasionally neutralized with acetic acid. If the solution does not show red ~ pale red color by adding 3 drops of phenolphthalein solution, the flask is set aside for 15 minutes in a boiling water bath. 30% of sodium sulfite solution (neutralized with acetic acid using phenolphthalein solution as an indicator) is slowly added until the insoluble oil rises up to the graduated marks of the flask. After setting aside for 1 hour, the amount is measured.

$$\text{Content of aldehydes and ketones (\%)} = 10 \times [10 \text{ amount of insoluble oil (mL)}]$$

(3) Hydroxylamine Method

Method 1

A specified amount of sample is precisely weighed and well mixed by shaking with 50 mL of 0.5 N hydroxylamine hydrochloride solution, which is set aside or gently boiled in a water bath using a reflux condenser for a specified period of time. It is then cooled to room temperature. Isolated acid is titrated with 0.5N alcoholic solution of potassium hydroxide. Separately, a blank test is carried out by the same procedure

$$\text{Content of aldehydes and ketones (\%)} = \frac{\text{molecular weight of aldehydes and ketones} \times (a - b) \times 0.5}{\text{Weight of sample(g)} \times 1,000} \times 100$$

a : consumed amount of 0.5 N alcoholic solution of KOH for test solution (mL)

b : consumed amount of 0.5 N alcoholic solution of KOH in a blank test (mL)

Method 2

A specified amount of sample is precisely weighed and mixed well by shaking in 75 mL of hydroxylamine solution, which is set aside or gently boiled in a water bath using a reflux condenser for a specified period of time. It is then cooled to room temperature. The excess amount of hydroxylamine is titrated with 0.5 N hydrochloric acid. The end point is where the color of solution changes from violet to greenish

yellow. Separately, a blank test is carried out by the same procedure.

$$\text{Content of aldehydes and ketones (\%)} = \frac{\text{molecular weight of aldehydes and ketones} \times (b - a) \times 0.5}{\text{sample(g)} \times 1,000} \times 100$$

a : consumed amount of 0.5N hydrochloric acid in test solution (mL)

b : consumed amount of 0.5N hydrochloric acid for blank test (mL)

36. Oils Test

Oils test is measured for acid value, saponification value and ester value about fatty acid, aliphatic alcohols, and ester of fatty acid except for flavoring.

A. Acid value : Unless otherwise directed, a specified amount of sample is accurately weighed and dissolved (by heating, if necessary) in approximately 50 mL of mixture of ethyl alcohol and ether (1:1), previously neutralized to 0.1N alcoholic potassium hydroxide (indicator : phenolphthalein TS). After cooling, add a few drops of phenolphthalein TS and titrate, while shaking, with 0.1N alcoholic potassium hydroxide TS to the first pink color that persists for at least 30 seconds.

Acid Value = Amount of 0.1N potassium hydroxide (mL) \times 5.611 / Weight of sample (g)

B. Saponification Value

Unless otherwise directed, a specified amount of sample is accurately weighed and dissolved in 40 mL of ethyl alcohol (by heating, if necessary), and added 20 mL of alcoholic potassium hydroxide TS. A reflux condenser is connected to the flask, which is gently boiled with shaking for 30 min in a water bath. After cooling, wash the condenser with a few mL of water, add a few drops of phenolphthalein TS and titrate the excess potassium hydroxide with 0.5N hydrochloric acid. Perform a blank determination using the same amount of alcoholic potassium hydroxide TS.

Saponification value = (a-b) \times 28.05 / weight of sample (g)

a: Consumed amount of 0.5N hydrochloric acid in blank test (mL)

b: Consumed amount of 0.5N hydrochloric acid in sample solution (mL)

C. Ester value

Unless otherwise specified, Ester value is calculated by the formula after measuring saponification value and acid value.

Ester value = saponification value - acid value

D. Hydroxyl Value

Unless otherwise specified, approximately 1g of the sample is accurately weighed and transfer it into a round flask indicated in the picture below. 5 mL of pyridine acetic anhydride reagent is accurately taken and placed in the flask. Small funnel is placed on the entrance of the flask, and the bottom of the flask is immersed about 1 cm in the oil bath of 95 ~ 100°C. Next, shake the flask, and heat for 10 minutes. After cooling, funnel and upper part of the flask are washed with 5 mL alcohol. Excess acetic acid is titrated with alcoholic potassium hydroxide (indicator: 1 mL of phenolphthalein TS). Blank test is conducted as the same manner.

Hydroxyl Value = (a-b) x 28.05/ sample weight (g) + acid value

a: Consumed amount of 0.5N alcoholic potassium hydroxide in blank test (mL)

b: Consumed amount of 0.5N alcoholic potassium hydroxide in sample solution (mL)

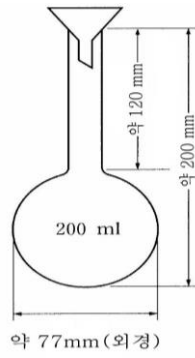

37. Test of Bactericidal Activity

Application and Principle : Test of Bactericidal Activity is for measuring whether food contact surface sanitizing solutions have or do not have a bactericidal activity. There are three tests : 1. test of bacterial suspension, 2. test of bacterial surface, and 3. test of spore suspension. Unless otherwise specified, measure by 1. test of bacterial suspension.

Definition of Bactericidal Activity : Reduction rate(%) in the number of viable bacterial cells(cfu/mL) corresponding to numbers of specified bacterial cells at the beginning (cfu/mL) under defined conditions regarding food contact surface sanitizing solutions.

Test 1. Test of bacterial suspension

There are dilution-neutralization and membrane filtration in this test. The test of dilution-neutralization is as follows: add the suspension of test bacteria containing interfering substances to a prepared test solution, incubate at 20°C for 5 minutes, immediately suppressed by a previously verified suitable neutralizer, determine the number of surviving bacteria in each sample and the reduction in viable counts is calculated. The test of membrane filtration can be used to suppress the bactericidal action by using filter film instead of neutralizer. In addition, verification test should be performed at the same time when this test is done.

1) Preparation of test solution

Test solution is prepared by taking a certain amount of sample into hard water at three different concentrations as follows. In addition, these test solutions should be prepared within 60 minutes for test..

- Solution A : The concentration of the solution is 1.25 times the required test concentration. However, in case of using undiluted solution itself, undiluted solution is solution A.
- Solution B and solution C : Solutions diluted 2 times and 4 times solution A.

2) Test Organisms

Use following 2 strains as standard organism.

- *Escherichia coli* ATCC 10536 or *Escherichia coli* ATCC 11229
- *Staphylococcus aureus* ATCC 6538

However, besides standard organisms above, additional strains can be chosen from, for example:

- *Bacillus cereus* ATCC 21772
- *Vibrio parahaemolyticus* ATCC 27969
- *Salmonella typhimurium* ATCC 13311
- *Listeria monocytogenes* ATCC 19111 (or *Listeria monocytogenes* ATCC 19115)

3) Working Cultures of Test Organisms

Test organisms spread on TSA medium and incubate at 36°C for 18 to 24 hours. Prepare a second subculture in the same way and prepare third subculture, again. The second or third subculture designate as the working culture. However, for working culture of *V. parahaemolyticus* among additional test organisms, 10 μl of test organisms inoculate on 10 mL of TSB medium, previously adjusted to 2% sodium chloride, and incubate at 36°C for 18 to 24 hours. After culture, second and third subculture is done in 100 mL of TSB medium, previously adjusted to 2% sodium chloride.

4) Preparation and counting of bacterial test suspension

(1) Preparation : Take 10 mL of diluent(TSCS) and place in a 100 mL erlenmeyer flask with 5 g of glass beads (diameter 3 ~ 4mm) and transfer *E. coli* working culture using a platinum loop. The cells should be suspended in the diluent by immersing the platinum loop in the diluent(TSCS) and rubbing it against the side of the flask to dislodge the cells. Shake the flask for 3 minutes using a mechanical shaker. Take the suspension from inside of the glass beads and transfer to another tube. Adjust the number of viable cells in the suspension to $1.5 \sim 5 \times 10^8$ cfu/mL with the diluent(TSCS). Incubate the suspension in the constant-temperature water bath at 20°C for 2 hours. This is *E. coli* bacterial test suspension.

Separately, prepare *S. aureus* working culture in the same manner as the above test preparation and prepare bacterial test suspension of *S. aureus*. However, for working culture of *V. parahaemolyticus* among additional test organisms, transfer working culture in 3) above into a sterilized 50 mL centrifuge tube. Centrifuge it at 20°C, 5000×g (6,000rpm) for 5 minutes and discard the supernatant carefully. Add 25 mL of diluent(TSCS) to residual cells and stir it for 10 seconds with a mechanical shaker. After stirring, centrifuge it again and discard the supernatant. Add 2 mL of diluent(TSCS) and suspend the cells. Take 10 mL of diluent(TSCS) and place in a 100 mL erlenmeyer flask filled with 5 g of glass beads. Add previously prepared bacterial suspension. Shake the flask for 3 minutes with a mechanical shaker. Adjust the number of viable cells in the suspension to $1.5 \sim 5 \times 10^8$ cfu/mL using diluent (TSCS). Incubate the suspension in the constant-temperature water bath at 20°C for 2 hours. This is bacterial test suspension.

(2) Counting : Prepare $10^{-6} \sim 10^{-7}$ dilutions of the *E. coli* bacterial test suspension with diluent(TSCS). Take 1 mL each of this fluid into the duplicate petri dishes and aseptically pipette approximately 15 mL of TSA medium maintaining 45°C. After cooling and solidifying, add 3~5 mL of TSA medium and duplicated. Upside down the cooled and solidified petri dishes and incubate at 36°C for 24 hours. Count the number of colony forming units in petri plates. Incubate the plates for a further 24 hours. When no longer plates show well separated colonies, count the highest number of colonies. Calculate the number of viable cells(N) in the *E. coli* test suspension with following equation.

$$\text{Count of viable cells in bacterial test suspension (cfu/mL)} = \frac{c}{(n_1 + 0.1n_2)d}$$

c : The sum of the colonies counted on petri plates

n_1 : The number of petri plates counted at the first dilution

n_2 : The number of petri plates counted at the secondary dilution

d : The dilution rate of first dilution

* Only colony counts which are 15~300 cfu/plate should be used for calculation of viable counts. For a result to be valid, viable counts should be calculated using at least 2 or more plates. If plates from two dilutions fall within this range, calculate the number of cfu/mL as the calculation above. If plates from only one dilution fall within this range, calculate the arithmetic mean. Round off the results calculated to two significant figures. For this, if the last figure is below 5, the preceding figure is not modified; if the last figure is more than 5, the preceding figure is increased by one unit; if the last figure is equal to 5, round off the preceding figure to the next nearest even figure in case of the preceding figure is odd, and make 0 in case of the preceding figure is even. Repeat this process until valid two figures are obtained. As a result, the number of cfu/mL is expressed by a number between 1.0 and 9.9 multiplied by a multiple of 10.

Separately, prepare *S. aureus* test suspension in the same manner as test procedure above and calculate the number of viable cells in *S. aureus* test suspension. The number of viable cells in each test suspension should be 1.5×10^8 cfu/mL ~ 5×10^8 cfu/mL.

5) Preparation and counting of bacterial test suspended diluent

(1) Preparation : Dilute *E. coli* test suspended diluent with diluent (TSCS) to adjust the number of viable cells of *E. coli* to $6 \times 10^2 \sim 3 \times 10^3$ cfu/mL. This is *E. coli* test suspended diluent.

Separately, prepare *S. aureus* test suspension in the same manner as above test procedure and prepare *S. aureus* test suspended diluent.

(2) Counting : Dilute *E. coli* bacterial suspended diluent 10 times with diluent(TSCS). Transfer 1 mL each of this solution into duplicate petri dishes and incubate in the same manner as (2) in 4) above. Count the highest number of colonies on petri plate. Calculate the number of viable bacterial cells(Nv) in *E. coli* bacterial suspended diluent under following equation.

The number of viable bacterial cells in test procedure

$$\text{and verification test (cfu/mL)} = \frac{c}{n \times d \times V}$$

c : The sum of the colonies counted on petri plates

n : The number of petri plates counted

d : The dilution factor (In case the dilution neutralization test procedure and the bacterial suspended diluent, the dilution factor is 10^{-1})

V : The volume of sample (In case the dilution neutralization and verification test, and the bacterial suspended diluent, the volume is 1.0 mL. In case the membrane filtration test and validation procedure, the volume is 0.1 mL.)

Separately, prepare *S. aureus* bacterial suspended diluent in the same manner as test procedure above and calculate the number of viable cells in *S. aureus* bacterial suspended diluent. The number of viable

cells in each bacterial suspended diluent should be 6×10^2 cfu/mL \sim 3×10^3 cfu/mL

6) Test Procedure

The temperature of product test solution, bacterial test suspension, bacterial suspended diluent, test solution, and water maintain at 20°C in a constant temperature water bath.

(1) Dilution-neutralization method

① Test Procedure

Transfer 1 mL of interfering substance and bacterial test suspensions into the test tube. Immediately mix it and incubate it in a constant temperature water bath at 20°C for 2 minutes. 8 mL of test solution (solution A) is added, mixed, and incubate in a constant temperature water bath at 20°C for 5 minutes. Pipette 1 mL of this mixture into a test tube filled with 8 mL of neutralizer and 1 mL of water. Neutralize it in a constant temperature water bath at 20°C for 5 minutes. After neutralization, take 1 mL each of neutralized mixture into duplicate petri dishes each. Incubate them by adding TSA medium as (2) in 4) above. Count the highest number of colonies on petri plate. Calculate the number of viable cells by sterilization (Na) with the formula (2) in 5) above.

Separately, proceed on *S. aureus* bacterial suspension and other test solutions (solution B and C) in the same manner as test procedure above. Calculate the number of viable cells by sterilization of test solution. However, for the sample with undiluted solution, add 9.8 mL of test solution (solution A) and add 0.1 mL of each of interfering substance and bacterial suspension with preparing their concentration 10 times higher than that used above. Proceed in the same manner as the test procedure above.

② Test for Validation

Ⓐ Validation of experimental conditions

Pipette 1 mL of interfering substance and 1 mL of bacterial suspended diluent into a test tube. Mix for a few seconds and incubate in a constant temperature water bath at 20°C for 2 minutes and add 8 mL of hard water, mix, and maintain it in a constant temperature water bath at 20°C for 5 minutes. Take 1 mL each of the mixture into duplicate petri dishes and incubate them under (2) in 4) above. Count the highest number of colonies on petri plate. Calculate the number of viable cells in test for validation of experimental condition under the formula (2) in 5) above.

Separately, proceed *S. aureus* suspended diluent in the same manner as test procedure above and calculate the number of viable cells. The number of viable cells in each test organism should be 0.05 times or more than the number of viable cells in test suspended diluent.

Ⓑ Neutralizer toxicity validation

Place 8 mL of neutralizer, 1 mL of water, and 1 mL of *E. coli* suspended diluent into a test tube. Mix for a few seconds and incubate in a constant temperature water bath at 20°C for 5 minutes. Take 1 mL each of the mixture into duplicate petri dishes and incubate them by adding TSA medium in the same manner as (2) in 4) above. Count the highest number of colonies on petri plate and calculate the number of viable cells (B) in neutralizer toxicity validation under the formula (2) in 5) above.

Separately, proceed *S. aureus* suspended diluent in the same manner as test procedure above and calculate the number of viable cells. At that time, the number of viable cells in each test organism should be 0.05 times or more than the number of viable cells in test suspended diluent.

© Dilution-neutralization validation

Place 1 mL of interfering substance, 1 mL of diluent(TSCS), and 8 mL of test solution (solution A) into a test tube. Mix for a few seconds and incubate in a constant temperature water bath at 20°C for 5 minutes. Take 1 mL of the mixture into a test tube filled with 8 mL of neutralizer and incubate it in a constant temperature water bath at 20°C for 5 minutes. To this solution, add 1 mL of *E. coli* suspended diluent, mix, and incubate in a constant temperature water bath at 20°C for 30 minutes. Take 1 mL each of the mixture into duplicate petri dishes and incubate them by adding TSA medium in the same manner as (2) in 4) above. Count the highest number of colonies on petri plate and calculate the number of viable cells (C) in dilution-neutralization validation under the formula (2) in 5) above.

Separately, proceed *S. aureus* suspended diluent in the same manner as test procedure above and calculate the number of viable cells. The number of viable cells in each test organism should be 0.5 times or more than the number of viable cells calculated in dilution-neutralization validation.

(2) Membrane Filtration Method

The temperature of product test solutions, bacterial suspension, test solution, and water is stabilized at 20°C in a constant temperature water bath.

① Test Procedure

Pipette 1 mL of interfering substance and 1 mL of *E. coli* test suspension into a test tube. Immediately mix and place the test tube in the constant temperature water bath at 20°C for 2 minutes. Add 8 mL of product test solution(solution A), mix, and leave in the constant temperature water bath at 20°C for 5 minutes. 0.1 mL each of the test mixture and 50 mL of the rinsing liquid transfer to two separate membrane filtration apparatus and immediately filter. The time required for filtration should not exceed 1 minute. Filter by adding 150~500 mL of rinsing liquid and 50 mL of water to each membrane filtration apparatus. The surface filtered of membrane place toward, closely face on TSA medium and incubated at 36°C for 24 hours. Care should be avoid let air in between the membrane and agar surface. Count the number of colonies on the petri plates and incubate the plates for a further 24 hours. When no longer plates show well-separated colonies, count the higher number of colonies in petri plates. Calculate the number of viable cells(N_a) by sterilization in the test solution under the formula (2) in 5).

Separately, proceed *S. aureus* test suspension and other test solutions(solution B and C) in the same manner as test procedure above and calculate the number of viable cells by sterilization of test solution. However, for the sample with undiluted solution, add 9.8 mL of test solution(solution A) and add 0.1 mL each of interfering substance and bacterial suspension with preparing their concentration 10 times

higher than that used above. Proceed in the same manner as the test procedure above.

② Test for Validation

Ⓐ Validation of experimental conditions

Proceed 1 mL of *E. coli* suspended diluent, 8 mL of hard water, and 50 mL of water instead of 1 mL of *E. coli* test suspension, 8 mL of test solution(solution A), and 150~500 mL of rinsing liquid from 6) (2) ① above, under the same manner as test above. Count the highest number of colonies for each petri plate and calculate the number of viable cells in the validation of experimental conditions under the formula (2) in 5) above.

Separately, proceed *S. aureus* suspended diluent in the same manner as test procedure above and calculate the number of viable cells in the validation of experimental conditions. The number of viable cells in each test organism should be 0.05 times or more than the number of viable cells in test suspended diluent.

Ⓑ Validation of the filtration procedure

Transfer 0.1 mL each of *E. coli* suspended diluent and 50 mL each of the rinsing liquid into two separate membrane filtration apparatus and filter immediately. Add 50 mL of water to each filtration apparatus, filter and incubate the filter paper in the same manner as 6) (2) ① above. Count the highest number of colonies on petri plates. Calculate the number of viable cells in the filtration control (B) in validation of the filtration procedure using the method (2) in 5) above.

Separately, proceed *S. aureus* suspended diluent in the same manner as test procedure above and calculate the number of viable cells in validation of the filtration procedure. The number of viable cells in each test organism should be 0.05 times or more than the number of viable cells in test suspended diluent.

Ⓒ Validation of the filtration method

Add 1 mL of interfering substance, 1 mL of diluent(TSCS), and 8 mL of test solution (solution A) into a test tube, mix and incubate in the constant temperature water bath at 20°C for 5 minutes. Transfer 0.1 mL of the test mixture and 50 mL of the rinsing liquid to a separate membrane filtration apparatus equipped, filter immediately. Filter by adding 150~500 mL of water. Add 50 mL of rinsing liquid and 0.1 mL of *E. coli* suspended diluent to each membrane filtration apparatus and filter. Add 50 mL of water additionally, filter, and incubate the filter paper in the same manner as ①, (2) in 6) above. Count the highest number of colonies on petri plate and calculate the number of viable cells(C) on the filtration control in validation of the filtration method using the method (2) in 5) above.

Separately, proceed *S. aureus* suspended diluent in the same manner as test procedure above and calculate the number of viable cells in validation of the filtration method. The number of viable cells in each test organism should be 0.5 times or more than the number of viable cells calculated in validation of the filtration procedure.

7) Conclusion

For each of test organism and product test solution, calculate the reduction rate of the number of viable cells in the bacterial test suspension under following formula. When the reduction in viability of solution A is not less than 99.999%, it is appropriate.

$$\text{Reduction in viability (\%)} = \frac{N - 10N_a}{N} \times 100$$

N_a - The number of viable cells by sterilization in test solution *(cfu/mL)

* Apply " 1.5×10^2 cfu/mL" as the number of viable cells(N_a) when counted colonies is not more than 15 and apply " 3×10^3 cfu/mL" as the number of viable cells(N_a) when counted colonies is not less than 300 in the product test procedure.

Test 2. Test of bacterial surface

A test suspension of bacteria in a solution of interfering substances is spread onto a stainless steel surface and dried. A prepared sample of the product under test is applied on the dried film and is maintained at 20°C for 5 minutes. The surface is transferred to a previously verified neutralization medium so that the action of the disinfectant is immediately neutralized. The reduction in viable counts is calculated by measuring the number of surviving organisms on each surface. However, main test proceed reference test using diluent instead of test solution, and perform test for validation at the same time.

1) Preparation of test solution

Product test solution is prepared in hard water at three different concentrations by taking a certain amount of sample as follows. In addition, these product test solutions should be prepared freshly and used within 60 minutes.

- Solution A : The solution is diluted to the required test concentration. However, in case of using undiluted solution itself, undiluted solution is solution A.
- Solution B and solution C : Solutions diluted 2 times and 4 times solution A.

2) Test Organisms

Use 2 strains as standard organism 2) in Test 1. Additional organisms are not used.

3) Working Cultures of Test Organisms

Follow 3) in Test 1.

4) Preparation and counting of bacterial test suspension

Follow 4) in Test 1.

5) Preparation for inoculating solution of test surfaces

Add $400 \mu\ell$ of *E. coli* bacterial suspension and $100 \mu\ell$ of interfering substance to a small test tube. Shake the test tube for 1 minute using a mechanical shaker. Maintain the suspension in the constant-temperature water bath at 20°C for 30 minutes. This is *E. coli* inoculating of test surface.

Separately, prepare inoculated test surfaces for *S. aureus* test suspension in the same manner as test procedure above.

6) Preparation of test surfaces

Inoculate 10 $\mu\ell$ of *E. coli* inoculated test surfaces onto the middle of carrier (\varnothing 1 cm \times 0.07 cm stainless steel disc ANSI 304 2B) and dry on 36 $^{\circ}$ C heat plate. This is *E. coli* test surface.

Separately, prepare test surface for *S. aureus* inoculated test surface in the same manner as test procedure above.

7) Test Procedure

The temperature of product test solution, test solution, apparatus, etc. should be stabilized at 20 $^{\circ}$ C. Carrier and glass bottle are previously dried in desiccator.

① Test Procedure

Carefully place the dried inoculated surfaces upwards and put it into a glass bottle (bottom diameter 2~3 cm, volume 15~20mL) using sterilized tongs. Add 50 $\mu\ell$ of product test solution (solution A) on the middle of test surface in glass bottle. Maintain it at 20 $^{\circ}$ C for 5 minutes. Add 9.95 mL of neutralizer and 2~3g of glass beads, mix for 1 minute in a mechanical shaker, and filter with membrane filtration apparatus. When filtering, rinse 100~150 mL of diluent(TSCS) 2 times or 3 times. Separate filtration membrane from membrane filtration apparatus and incubate following ①, (2) in Test 1. Proceed the test procedure above five times with prepared *E. coli* test surface. Count the highest number of colonies in each petri plate. Calculate the number of viable cells by sterilization in the test solution(Nd) under the following equation.

The number of viable bacterial cells in test procedure

$$\text{and test for validation (cfu/carrier)} = \frac{c}{n \times d}$$

c : the sum of the colonies counted on petri plates taken into account

n : the number of petri plates taken into account

d : the dilution factor corresponding to the dilution taken into account

Separately, calculate the number of viable cells(Nc) in reference test by using diluent (TSCS). Dilute the mixture by 10 $^{-2}$, 10 $^{-3}$, and 10 $^{-4}$ with diluent (TSCS) and filter with membrane filtration apparatus. Proceed the test procedure of surface 3 times.

Proceed *S. aureus* test surface and other test solutions(solution B and C) in the same manner as test procedure above. Calculate the number of viable cells by sterilization of test solution. The number of viable cells in reference test of each cell should be more than 1.5 \times 10 5 cfu/carrier under the formula above.

② Test for Validation

Ⓐ Validation of neutralization

Add 9.95 mL of neutralizer and 50 $\mu\ell$ of test solution(solution A) into glass bottle. Mix and maintain at 20 $^{\circ}$ C for 5 minutes. Then add *E. coli* test surface and 2~3 g of glass bead. Mix for 1 minute in a mechanical shaker. Dilute the mixture by 10 $^{-3}$, 10 $^{-4}$ and 10 $^{-5}$ with diluent (TSCS) and filter with membrane filtration apparatus. When filtering, rinse 100~150 mL of diluent (TSCS) 2 times or 3 times. Separate

filtration membrane from membrane filtration apparatus and incubate following ①, (2) in Test 1. Proceed the described test procedure above two times with previously prepared *E. coli* test surface. Count the highest number of colonies in each petri plate. Calculate the number of viable cells (B) in validation of neutralization under the equation ① in 7) above.

Separately, proceed *S. aureus* test surface in the same manner as the test procedure above. Calculate the number of cfu/mL in validation of neutralization. The number of viable cells of each bacterial organism should be more than 1.5×10^5 cfu/carrier.

Ⓑ Neutralizer toxicity validation

Proceed under test for validation using diluent(TSCS) instead of test solution(solution A) in Ⓐ, ② in 7) above. Count the highest number of colonies in each petri plate. Calculate the number of viable cells(A) in Neutralizer toxicity validation under the equation ① in 7) above.

Separately, proceed *S. aureus* test surface in the same manner as test procedure above. Calculate the number of viable cells in neutralizer toxicity validation. The number of viable cells in each test organism should be not less than 0.5 times and not more than 2 times the number of cfu/mL counted in neutralizer toxicity validation.

8) Conclusion

For each test organism and product test solution, calculate the reduction of the number of viable cells in each test organism under following formula. When the reduction in viability of solution A is more than 99.99%, it is appropriate.

$$\text{Reduction in viability(\%)} = \frac{N_c - N_d}{N_c} \times 100$$

N_c - Viable counts in reference test (cfu/carrier)

N_d - The number of viable cells by sterilization in test solution *(cfu/carrier)

* Apply " 1.5×10^5 cfu/carrier" as the number of viable cells when counted colonies is not more than 15 and apply " 3×10^2 cfu/carrier" as the number of viable cells when counted colonies is not less than 300 in the product test procedure.

Test 3. Test of spore suspension

There are dilution-neutralization and membrane filtration in this test. The test of dilution-neutralization is as follows : add a spore suspension in a solution of interfering substances to a prepared test solution, maintain at 20°C for 60 minutes, immediately suppressed by a previously verified suitable neutralizer, determine the number of spore in each sample and the calculate reduction rate. If a suitable neutralizer cannot be found, membrane filtration can be used to suppress the bactericidal action by using filter film instead of neutralizer.

In addition, verification test should be performed at the same time when this test is done.

1) Preparation of test solution

Test solution is prepared in hard water at three different concentrations by taking a certain amount of sample as follows. In addition, these test solutions should be prepared freshly and used within 60 minutes.

- Solution A : The concentration of the solution is 1.25 times the required test concentration. However, in case of using undiluted solution itself, undiluted solution is solution A.
- Solution B and solution C : Solutions diluted 2 times and 4 times solution A.

2) Test Organisms

Use *Bacillus subtilis* ATCC 6633

3) Preparation of spore solution

Inoculate about 10^6 spores on Nutrient Broth and incubate at 30°C for 18~24 hours. Inoculate 2~3 mL of this culture medium into Roux bottle solidified by Nutrient Agar containing manganese sulfate and incubate at 30°C for 14 days. Concentrate bacterial cells with sterilized glass beads and water. Centrifuge it at 10,000rpm for 20 minutes, discard the supernatant, float in the water, and rinse. Repeat this procedure 3 times. Float the residue in the water and heat at 75°C for 10 minutes. Keep this spore solution in the refrigerator. For long-term preservation, keep it in a freezer.

4) Preparation and counting of spore suspension

(1) Preparation : Dilute spore solution with water to adjust the number of viable cells to $1.5 \sim 5 \times 10^6$ cfu/mL. Maintain it in a constant temperature water bath at 20°C . This is spore suspension. This solution should be used within 2 hours after preparation.

(2) Counting : Prepare $10^{-4} \sim 10^{-5}$ dilutions of the spore suspension with water. Add 1mL of each dilution to duplicate petri plates, add nutrient agar with 45°C . Incubate under (2), 4) in Test 1 and calculate the number of spore (N) of spore suspension. Then, the number of spore in spore suspension should be $1.5 \sim 5 \times 10^6$ cfu/mL.

5) Preparation and counting of spore suspended diluent

(1) Preparation : Dilute spore suspended diluent with water to adjust the number of spores to $6 \times 10^2 \sim 3 \times 10^3$ cfu/mL. This is spore suspended diluent.

(2) Counting : Dilute spore suspended diluent 10 times with water. Transfer 1 mL each of this solution into 2 separate petri dishes and add nutrient Agar stabilized at 45°C . Incubate in the same manner as (2) in 4) above. Count the highest number of colonies on petri plate. Calculate the number of viable cells in spore suspended diluent (N_v) under the equation in (2) 5) in Test 1. The number of spores in spore suspended diluent should be 6×10^2 cfu/mL $\sim 3 \times 10^3$ cfu/mL

6) Test procedure

Use following contact temperature(θ) and contact time(t).

- Contact temperature(θ) : 20°C
- Contact time(t) : 60 minutes

However, following additional conditions may be chosen except conditions above.

- Contact temperature(θ) : 4°C, 10°C, 40°C or 75°C, etc.
- Contact time(t) : 5 minutes, 15 minutes or 30 minutes, etc.

All reagent should be stabilized at following temperature before test.

- contact temperature(θ) (NMT 40°C) : test solution, spore suspension, interfering substance are stabilized at θ C in constant temperature water bath. neutralizer and water are stabilized at 20°C.
- contact temperature(θ) (more than 40°C) : test solution is stabilized at θ C. neutralizer, spore suspension, interfering, and water are stabilized at 20°C.

(1) Dilution-neutralization method

① Test Procedure

Pipette 1 mL of interfering substance and 1 mL of spore suspensions into a test tube. Immediately mix and maintain it in a constant temperature water bath at θ C for 2 minutes. 8 mL of test solution (solution A) is added, mixed, and maintained in a constant temperature water bath at θ C for 5 minutes. Pipette 1 mL of this mixture, transfer it into a test tube filled with 8 mL of neutralizer and 1 mL of water. Neutralize it in a constant temperature water bath at 20°C for 5 minutes. After neutralization, take 1 mL of neutralized mixture into 2 separate petri dishes and incubate them by adding nutrient agar under (2) in 4) in Test 1. Count the highest number of colonies on petri plate and calculate the number of spores by sterilization (N_a) with the formula (2), 5) in Test 1.

Separately, proceed other test solutions(solution B and C) in the same manner as test procedure above and calculate the number of spores by sterilization of test solution. However, for the sample with undiluted solution, add 9.8 mL of test solution(solution A) and add 0.1 mL each of interfering substance and bacterial suspension to prepared their concentration 10 times higher than that used above. Proceed in the same manner as the test procedure above.

② Test for Validation

Ⓐ Validation of experimental conditions

Pipette 1 mL of interfering substance and 1 mL of spore suspended diluent into a test tube. Mix for a few seconds and leave in a constant temperature water bath at θ C for 2 minutes. Add 8 mL of hard water, mix, and maintain it in a constant temperature water bath at θ C for t minutes. Take 1 mL each of the mixture and transfer into 2 separate petri dishes. Incubate them under (2), 4) in Test 1. Count the highest number of colonies on petri plate. Calculate the number of spores (A) in test for validation of experimental condition under the formula (2), 5) in Test 1. The number of spores in each test organism should be 0.05 times or more than the number of spores in spore suspended diluent.

Ⓑ Neutralizer toxicity validation

Place in a test tube, 8 mL of neutralizer, 1 mL of water, and 1 mL of spore suspended diluent. Mix for a few seconds and leave in a constant temperature water bath at 20°C for 5 minutes. Take a sample of 1 mL each of the mixture and transfer into 2 separate petri dishes. Incubate them by adding nutrient agar in the same manner as (2) in 4) in Test 1. Count the highest number of colonies in petri plate. Calculate the number of viable cells in Neutralizer toxicity validation (B) under the formula (2) in 5) in Test 1.

The number of spores should be 0.05 times or more than the number of spores in spore suspended diluent.

© Dilution-neutralization validation

Place in a test tube, 1 mL of interfering substance, 1 mL of water, and 8 mL of test solution (solution A). Mix for a few seconds and leave in a constant temperature water bath at $\theta^{\circ}\text{C}$ for t minutes. Transfer 1 mL of the mixture into a test tube filled with 8 mL of neutralizer. Leave it in a constant temperature water bath at 20°C for 5 minutes. To this solution, add and mix 1 mL of spore suspended diluent and leave in a 20°C constant temperature water bath for 30 minutes. Take a sample of 1 mL each of the mixture and transfer into 2 separate petri dishes. Incubate them by adding nutrient agar in the same manner as (2) in 4) in Test 1. Count the highest number of colonies in petri plate. Calculate the number of spores (C) in Dilution-neutralization validation under the formula (2) in 5) in Test 1. The number of spores should be 0.5 times or more than the number of spores calculated in Neutralizer toxicity validation.

(2) Membrane Filtration Method

① Test Procedure

Pipette 1 mL of interfering substance and 1 mL of spore suspended diluent into a test tube. Immediately mix and place the test tube in a constant temperature water bath at $\theta^{\circ}\text{C}$ for 2 minutes. Add 8 mL of product test solution(solution A), mix, and leave in a constant temperature water bath at $\theta^{\circ}\text{C}$ for t minutes. Pipette 0.1 mL each of the test mixture and transfer each of sample and 50 mL of the rinsing liquid into a separate membrane filtration apparatus and filter immediately. The time required for filtration should not exceed 1 minute. First, filter 150~500 mL of rinsing liquid and additionally filter 50 mL of water to each membrane filtration apparatus. The upper side of the membrane placed closely on the nutrient agar and incubated at 36°C for 24 hours. Care should be avoid let air in between the membrane and agar surface. Count the number of colonies on petri plates and incubate the plates for a further 24 hours. When no longer plates show well-separated colonies, count the highest number of colonies on petri plates. Calculate the number of spores by sterilization in the test solution under the formula (2), 5) in Test 1. However, for the sample with undiluted solution, add 9.8 mL of test solution(solution A) and add 0.1 mL of each of interfering substance and bacterial suspension with preparing their concentration 10 times higher than that used above. Proceed in the same manner as the test procedure above.

② Test for Validation

Ⓐ Validation of experimental conditions

Proceed 1 mL of spore suspended diluent, 8 mL of hard water, and 50 mL of water instead of 1 mL of spore suspension, 8 mL of test solution(solution A), and 150~500 mL of rinsing liquid, under the same manner as test above. Count the highest number of colonies on each petri plate and calculate the number of spores in the validation of experimental conditions (A) under the formula given in 5), (2) in

Test 1. The number of spores should be 0.05 times or more than the number of spores in spore suspended diluent.

Ⓑ Validation of the filtration procedure

Take 0.1 mL each of spore suspended diluent. Transfer each of sample and 50 mL of the rinsing liquid into two separate membrane filtration apparatus and filter immediately. After filtering 50 mL of water to each filtration apparatus and incubate the filter paper in the same manner as ①, (2), (6) in Test 1. Count the highest number of colonies on petri plates. Calculate the number of spores in the filtration control (B) in validation of the filtration procedure (2), (5) in Test 1. The number of spores should be 0.05 times more than the number of spores in spore suspended diluent.

Ⓒ Validation of the filtration method

Place in a test tube, 1 mL of interfering substance, 1 mL of water, and 8 mL of test solution (solution A). Mix and leave in a constant temperature water bath at $\theta^{\circ}\text{C}$ for t minutes. Pipette 0.1 mL each of the test mixture and transfer each of sample and 50 mL of the rinsing liquid into a separate membrane filtration apparatus and filter. Filter by adding 150~500 mL of water again. Add 50 mL of rinsing liquid and 0.1 mL of spore suspended diluent to each membrane filtration apparatus and filter. Add 50 mL of water additionally, filter, and incubate the filter paper in the same manner as ①, (2), (6) in Test 1. Count the higher number of colonies on petri plates. Calculate the number of spores in the filtration control (C) in validation of the filtration method under the formula 5) (2) in Test 1. The number of spores should be 0.5 times or more than the number of spores calculated in validation of the filtration procedure.

7) Conclusion

For each test solution, calculate the reduction rate under following formula, respectively. When the reduction rate of the number of spores of solution A is more than 99.9%, it is appropriate.

$$\text{Reduction rate of spores (\%)} = \frac{N - 10N_a}{N} \times 100$$

N_a - The number of spores by sterilization in test solution *(cfu/mL)

* Apply " 1.5×10^2 cfu/carrier" as the number of viable cells when counted colonies is 15 or below and apply " 3×10^3 cfu/mL" as the number of viable cells when counted colonies is more than 300 in the product test procedure.

Apparatus

Membrane filtration apparatus : It should have a usable volume 50 mL minimum, and suitable filtration membrane (diameter:47 ~ 50mm, pore size:0.45 μm) should be used. In vacuum, the filtration rate should be equal so that microorganism can be distributed uniformly on the whole filtration membrane. To

avoid long time filtration, it should be designed for 100 mL of rinsing liquid to be filtered between 20 seconds and 40 seconds.

Culture media

1) TSA (Tryptone Soya Agar)

Tryptone, pancreatic digest of casein	15.0g
Soya peptone, papaic digest of soybean meal	5.0g
NaCl	5.0g
Agar	15.0g

Dissolve above ingredients in 1,000 mL of distilled water. Adjust the pH to 7.2 and sterilize at 121°C for 15 minutes.

2) TSB (Tryptone Soya Broth)

Tryptone, pancreatic digest of casein	15.0g
Soya peptone, papaic digest of soybean meal	5.0g
NaCl	5.0g

Dissolve above ingredients in 1,000 mL of distilled water. Adjust the pH to 7.2 and sterilize at 121°C for 15 minutes.

3) Nutrient Broth

Peptone	10.0g
Beef Extract	3.0g

Dissolve above ingredients in 1,000 mL of distilled water. Adjust the pH to 7.2 and sterilize at 121°C for 15 minutes.

4) Nutrient Agar

To 1,000 mL of nutrient agar, add 15.0g of refined agar, heat, dissolve, and correct the content of distilled water. Adjust the pH to 6.8 and sterilize at 121°C for 15 minutes.

5) Amended Nutrient Agar

To Nutrient Agar, add manganese sulfate($MnSO_4 \cdot H_2O$) so that the content becomes $5\mu g/mL$. Sterilize at 121°C for 15 minutes.

Test solution

1) Sterilized phosphate buffer solution

Dissolve 34 g of anhydrous potassium dihydrogen phosphate in 500 mL of distilled water. Add 175 mL of 1N sodium hydroxide to adjust the pH to 7.2. Add distilled water to make 1,000mL, phosphate buffer solution. Sterilize this solution at 121°C for 20 minutes. Dilute 1 mL of this solution in 800 mL of sterilized distilled water, sterilized phosphate buffer solution.

2) Water

The water shall be free from substances that are toxic or inhibiting to the bacteria. It shall be distilled water and not demineralized water. Sterilize at 121°C for 15 minutes.

3) Diluent (TSCS)

Tryptone Sodium Chloride Solution:

Tryptone, pancreatic digest of casein	1.0g
NaCl	8.5g

Dissolve above ingredients in 1,000 mL of distilled water. Adjust the pH to 7.2 and sterilize at 121°C for 15 minutes.

4) Neutralizer

Choose proper one of the following neutralizers and use sterile one. The neutralizer should be validated in the test for validation.

(1) Neutralizers

lecithin	3g
polysorbate 80	30g
sodium thiosulfate	5g
L-histidine	1g
saponine	30g

Dilute above ingredients to 1,000 mL by adding 1% sterilized phosphate buffer solution or diluent.

(2) Sterilized phosphate buffer solution

Dissolve 34 g of potassium dihydrogen phosphate(KH_2PO_4) in 500mL of water. Adjust the pH to 7.2 using 1N sodium hydroxide. Dilute this solution to 1,000 mL with water.

(3) 5% or 0.5%(V/V) egg yolk solution

Dilute 10 mL or 1 mL of sterilized egg yolk solution (the same amount of sterilized physiological saline is added to egg yolk solution) to 100 mL with water.

(4) Solution containing 3%(V/V) polysorbate 80, sodium lauryl sulfate at 4g//, and lecithin at 3g//.

(5) Solution containing 5%(V/V) egg yolk and 4%(V/V) polysorbate 80

(6) Solution containing 7%(V/V) ethylene oxide condensate of fatty alcohol, lecithin at 20g//, and 4%(V/V) polysorbate 80

(7) Solution containing 4%(V/V) ethylene oxide condensate of fatty alcohol and lecithin at 4g//.

(8) Solution containing 3%(V/V) polysorbate 80, lecithin at 3g//, and histidine at 1g//.

(9) Glycine

(10) Solution containing 3%(V/V) polysorbate 80 and lecithin at 3g//.

(11) Solution containing phospholipid emulsion at 50mg/mL and lecithin at 4g//.

(12) Sodium thioglycollate solution at 0.05g// or 0.5g//

(13) Cysteine solution at 0.8g// or 1.5g//

(14) Sodium thiosulfate solution at 0.5g//

With the exception of list above, other suitable neutralizer can be used.

5) Rinsing solution

Sterilized rinsing liquid should be used. Rinsing liquid should be filtered through membrane. One of the following rinsing liquid can be used.

- (1) water
- (2) diluent (TSCS)
- (3) solution of 0.1%(V/V) polysorbate 80
- (4) solution of 0.5%(V/V) polysorbate 80
- (5) solution of 0.5%(V/V) polysorbate 80 and lecithin at 0.7g//
- (6) neutralizer
- (7) sterilized phosphate buffer solution

The list above is not exhaustive and other liquids can be used.

6) Hard water

Hard water for dilution of products is prepared as follows.

- solution A : Dissolve 19.84g of anhydrous magnesium chloride and 46.24g of anhydrous calcium chloride in water and make to 1l.
- solution B : Dissolve 35.02g of sodium hydrogen carbonate in water and make to 1,000mL.

Add 3.0 mL of solution A and at least 600 mL of water into a 1,000 mL volumetric flask, then add 8.0 mL of solution B and dilute to 1,000 mL with water. Adjust the pH of the solution to 7.0. Sterilize by passing through a filter with a maximum effective pore size of 0.45 μ m or below. The solution can be stored at 4 ~ 8°C for a maximum one month.

7) Interfering substances in Test of bacterial suspension or Test of spore suspension. Bovine albumin solution(clean condition or dirty condition) should be used as interfering substance. When precipitate is generated by the action between interfering substance and test solution, the following suitable interfering substance can be chosen to be tested.

(1) Bovine albumin solutions

Bovine albumin solutions for the test conditions is prepared as follows :

- Preparation for clean conditions

Dissolve 0.3g of bovine albumin (Cohn fraction V for Dubos medium) in 100mL of water and sterilize by membrane filtration.

- Preparation for dirty conditions

Dissolve 3g of bovine albumin (Cohn fraction V for Dubos medium) in 100mL of water and sterilize by membrane filtration.

(2) Milk

100 g of powdered milk, guaranteed free of antibiotics or additives, is dissolved in 1l of water and

prepared to 10%(V/V) solution. Sterilize for 30 minutes at 105°C(or for 5 minutes at 121°C).

(3) Yeast extract

Dissolve dehydrated yeast extract to 100g// with water. Adjust the pH to 7.0 ± 0.2 using NaOH. Sterilize at 121°C for 15 minutes.

(4) Sucrose

Dissolve sucrose to 100g// with water. Sterilize it using filtration membrane.

(5) pH 5 and pH 9 buffer solutions

(6) Sodium lauryl sulfate

Dissolve sodium lauryl sulfate to 50g// with water. Sterilize at 121°C for 15 minutes.

8) Interfering substance of test of bacterial surface

Interfering substance used for reflecting real use condition is prepared by mixing bovine albumin solution and tryptone solution. Prepare and store under following preparation method.]

- Bovine albumin solutions : Add 0.3 g of albumin to 10 mL of sterilized phosphate buffer solution, filter and sterilize it.
- Tryptone solution : Add 0.1 g of tryptone to 10 mL of sterilized phosphate buffer solution. filter and sterilize it.

Mix $50 \mu\ell$ each of filtered and sterilized solutions(1:1) just before use and store it at 20°C.

V. Reagents.test solutions.volumetric standard solutions and standard solutions

Please refer to the original text.

VI. Re-examine Deadline

According to 「Framework Act on Administrative Regulations」Article 8 and 「Regulations on the Issuance and Management of Directives and Standing Rules」(Presidential Directive No.248), this shall be reviewed for improvement and other actions for every three years (which refers to until December 31 of every three years) as of January 1st, 2017.

**[Annex 1] Matters concerning Application for Establishment of Standards and Specifications
of Food Additives and Revision of Use Level**

Please refer to the original text.

[Table 1] Submission Date for Establishment of Standards and Specifications of Food Additives and Revision of Use Level

Please refer to the original text.

**[Annex Form No.1] Application form for Establishment of Standards and Specifications of
Food Additives**

Please refer to the original text.

[Annex 2] List No Longer Recognized as Food Additives

Cancelation Date	Food Additives	Reasons
1996.04.26.	Potassium bromate	Safety issues
2004.07.16.	Madder Color	Safety issues
2005.12.14.	Lactones	Deletion in individual additives list due to the list establishment of Synthetic Flavoring Substances
2005.12.14.	Aromatic aldehydes	Deletion in individual additives list due to the list establishment of Synthetic Flavoring Substances
2005.12.14.	Aromatic alcohols	Deletion in individual additives list due to the list establishment of Synthetic Flavoring Substances
2005.12.14.	Esters	Deletion in individual additives list due to the list establishment of Synthetic Flavoring Substances
2005.12.14.	Ethers	Deletion in individual additives list due to the list establishment of Synthetic Flavoring Substances
2005.12.14.	Isothiocyanates	Deletion in individual additives list due to the list establishment of Synthetic Flavoring Substances

Cancelation Date	Food Additives	Reasons
2005.12.14.	Indole, Amin, Oxazole, Thiazole, Quinoline, Pyrazine, Pyrrole, Pyridine and its derivatives	Deletion in individual additives list due to the list establishment of Synthetic Flavoring Substances
2005.12.14.	Fatty acids	Deletion in individual additives list due to the list establishment of Synthetic Flavoring Substances
2005.12.14.	Aliphatic aldehydes	Deletion in individual additives list due to the list establishment of Synthetic Flavoring Substances
2005.12.14.	Aliphatic alcohols	Deletion in individual additives list due to the list establishment of Synthetic Flavoring Substances
2005.12.14.	Aliphatic hydrocarbons	Deletion in individual additives list due to the list establishment of Synthetic Flavoring Substances
2005.12.14.	Thioalcohols	Deletion in individual additives list due to the list establishment of Synthetic Flavoring Substances
2005.12.14.	Thioethers	Deletion in individual additives list due to the list establishment of Synthetic Flavoring Substances

Cancelation Date	Food Additives	Reasons
2005.12.14.	Ketones	Deletion in individual additives list due to the list establishment of Synthetic Flavoring Substances
2005.12.14.	Phenols	Deletion in individual additives list due to the list establishment of Synthetic Flavoring Substances
2005.12.14.	Phenol Ethers	Deletion in individual additives list due to the list establishment of Synthetic Flavoring Substances
2005.12.14.	Furfural and its derivatives	Deletion in individual additives list due to the list establishment of Synthetic Flavoring Substances
2005.12.14.	Terpene Hydrocarbons	Deletion in individual additives list due to the list establishment of Synthetic Flavoring Substances
2006.12.27.	Basic Sodium Aluminium Carbonate	No designation in major foreign countries. No information of domestic use has been received.
2008.06.24.	Propyl ρ -Hydroxybenzoate	Safety issues
2009.01.02.	Butyl ρ -Hydroxybenzoate	Safety issues
2009.01.02.	Isobutyl ρ -Hydroxybenzoate	Safety issues
2009.01.02.	Isopropyl ρ -Hydroxybenzoate	Safety issues

Cancelation Date	Food Additives	Reasons
2009.07.10.	Kusagi Color	No designation in major foreign countries. No information of domestic use has been received.
2009.07.10.	Peanut Color	No designation in major foreign countries. No information of domestic use has been received.
2009.07.10.	Corn Color	No designation in major foreign countries. No information of domestic use has been received.
2009.11.19.	Sodium Dichloroisocyanurate	Safety issues
2010.11.12.	Trisodium Glycyrrhizinate	No designation in major foreign countries. No information of domestic use has been received.
2010.11.12.	Dehydroacetic Acid	No designation in major foreign countries. No information of domestic use has been received.
2010.11.12.	Thiamine Naphthalene-2,6-disulfonate	No designation in major foreign countries. No information of domestic use has been received.
2010.11.12.	Thiamine Phenolphthalinate	No designation in major foreign countries. No information of domestic use has been received.

Cancelation Date	Food Additives	Reasons
2010.11.12.	Defatted Ricebran Extract	No designation in major foreign countries. No information of domestic use has been received.
2010.11.12.	Bleaching Powder	No designation in major foreign countries. No information of domestic use has been received.
2012.03.27.	Crayfish Color	No designation in major foreign countries. No information of domestic use has been received.
2012.03.27.	L-Sorbose	No designation in major foreign countries. No information of domestic use has been received.
2012.03.27.	Mutastein	No designation in major foreign countries. No information of domestic use has been received.
2012.03.27.	Krill Color	No designation in major foreign countries. No information of domestic use has been received.
2015.02.24.	3-acetyl- 2,5-dimethylthiophene (A018, Synthetic Flavoring Substances)	Safety issues
2018.06.29.	C006 Capsaicin (Synthetic Flavoring Substances)	Safety issues
2018.06.29.	D210 2,5-Dimethylthiophene (Synthetic Flavoring Substances)	Safety issues

Cancelation Date	Food Additives	Reasons
2018.06.29.	E002 4,5-Epoxy-(E)-2-decenal (Synthetic Flavoring Substances)	Safety issues
2018.06.29.	E175 2-Ethylthiophene (Synthetic Flavoring Substances)	Safety issues
2018.06.29.	F036 Pyrrole-2-carbaldehyde (Synthetic Flavoring Substances)	Safety issues
2018.06.29.	M009 p-Mentha-1,8-dien-7-al (Synthetic Flavoring Substances)	Safety issues
2018.06.29.	M014 Menthadienol (Synthetic Flavoring Substances)	Safety issues
2018.06.29.	M020 Menthofuran (Synthetic Flavoring Substances)	Safety issues
2018.06.29.	M375 Myrtenyl formate (Synthetic Flavoring Substances)	Safety issues
2018.06.29.	M402 2-Methylthiophene (Synthetic Flavoring Substances)	Safety issues
2018.06.29.	M411 3-Methylthiophene (Synthetic Flavoring Substances)	Safety issues
2018.06.29.	M436 Methyl methanethiosulfonate (Synthetic Flavoring Substances)	Safety issues
2018.06.29.	N037 3-Nonanon-1-yl acetate (Synthetic Flavoring Substances)	Safety issues
2018.06.29.	P166 Pulegone (Synthetic Flavoring Substances)	Safety issues
2018.06.29.	P185 Pentan-2,4-dione (Synthetic Flavoring Substances)	Safety issues
2018.06.29.	P201 Propyl propane thiosulfonate (Synthetic Flavoring Substances)	Safety issues
2018.06.29.	S014 Styrene (Synthetic Flavoring Substances)	Safety issues
2018.06.29.	T069 2,6,6-Trimethyl-1-cyclohexen-1-carboxaldehyde (Synthetic Flavoring Substances)	Safety issues
2018.06.29.	V018 Vetiverol (Synthetic Flavoring Substances)	Safety issues
2018.06.29.	V019 Vetiveryl acetate (Synthetic Flavoring Substances)	Safety issues

[Annex 3] Specifications of Trichloroethylene, Methylene Chloride and 1-hydroxyethylidene-1,1-diphosphoric acid(HEDP)

Trichloroethylene

Ethylene Trichloride

1,1,2-Trichloroethylene

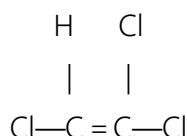

C 2 H C l 3

Molecular Weight 131.39

Compositional Specifications of Trichloroethylene

Description Trichloroethylene is a colorless, transparent liquid with a chloroform-like odor and sweetness.

Purity (1) Specific Gravity : Specific gravity of Trichloroethylene should be within a range of 1.454~1.458

(2) Acidity and alkalinity : Apply 2 drops of phenolphthalein solution to 25 mL of water, add 0.01N sodium hydroxide solution until a pale red color appears, and shake it by adding 25 mL (amount equivalent to 36g) of this item for 30 seconds. If a pale red color exists, the consumption shall be not more than 0.9 mL when shaken repeatedly until the pale red color disappears and titrated with 0.01 N hydrochloric acid. After a pale red color disappears, the consumption of 0.01N sodium hydroxide solution shall not be more than 1.0 mL when titrate with the 0.01N sodium hydroxide solution until a pale red color appears.

(3) Lead: When trichloroethylene is taken and tested in accordance with the atomic absorption photometry or the induction combined plasma luminous intensity method, the amount shall not be more than 1.0 ppm.

(4) Distillation test: When measuring oil in accordance with the viscosity and fluid measurement method, a minimum of 95 % (v/v) shall be spilled at 86 to 88°C.

(5) Released halogen: When adding 10 mL of an iodine potassium solution (1→10) and 1 mL of an starch test solution, the color blue shall not appear in the water layer.

(6) Evaporative residues: When 69 mL of trichloroethylene(approximately 100g) is dried in a bath for 30 minutes at 105°C, the amount shall not be more than 10 ppm.

Moisture The moisture of trichloroethylene shall not be more than 0.05 % when tested in accordance with the Water Quantification Method (Cal-Fisher Method).

Methylene Chloride

Dichloromethane

C H₂ C l₂

Molecular Weight 84.93

Compositional Specifications of Methylene Chloride

Description Methylene Chloride is a colorless, nonflammable liquid.

Purity (1) Specific Gravity : Specific gravity of Trichloroethylene should be within a range of 1.318~1.323

(2) Acidity(as hydrochloric acid) : Approximately 100 mL(about 132 g) of Methylene Chloride shall be put in a separatory funnel with 100 mL of water and shake intensely for two minutes. When water layer is taken and titrated with a 0.01N sodium hydroxide solution, its consumption shall not be more than 3.6 mL(indicator: 4 drops of Bromothymol blue).

(3) Lead: When methylene chloride is taken and tested in accordance with the atomic absorption photometry or the induction combined plasma luminous intensity method, the amount shall not be more than 1.0 ppm.

(4) Distillation test: When measuring oil in accordance with the viscosity and fluid measurement method, a minimum of 95 % (v/v) shall be spilled at 39.5 to 40.5 °C.

(5) Released halogen: 10 mL of Methylene Chloride is put in a separatory funnel with 25 mL of water, and shake intensely for one minute. When layers are completely separated, discard lower layer. Then put 1 mL of iodine potassium test solution and several drops of starch test solution to the water layer, and blue color shall not appear when waiting for 5 minutes.

(6) Evaporative residues: When 38 mL of methylene chloride(approximately 50 g) is dried in a bath for 30 minutes at 105°C, the amount shall not be more than 20 ppm.

Moisture The moisture of methylene chloride shall not be more than 0.02 % when tested in accordance with the Water Quantification Method (Cal-Fisher Method).

1-hydroxyethylidene-1,1-diphosphonic acid(HEDP)

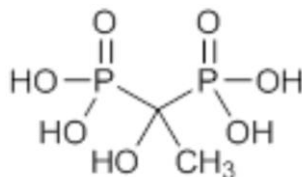

Formula: $C_2H_8O_7P_2$

Molecular weight: 206.03

Synonyms: Phosphonic acid,(1-hydroxyethylidene)bis-

CAS No. : 2809-21-4

Compositional Specifications of 1-hydroxyethylidene-1,1-diphosphonic acid(HEDP)

Content It contains within a range of 58.0 ~ 62.0 % of HEDP.

Description HEDP is a clear, transparent liquid with a colorless~pale yellow color.

Purity (1) Acidity : This solution(1→100) should not be more than pH 2.0.

(2) Specific gravity: The specific gravity of HEDP is 1.430~1.471.

(3) Chloride: When tested in accordance with the Chloride Limit Test by precisely weighing 5 g of HEDP, the amount shall not be more than the corresponding 0.56 mL of 0.01 N hydrochloric acid (not more than 0.004 %)

(4) Phosphorous acid: Weigh 1.5 g of HEDP precisely and put it into an iodine flask and add 20 mL of water and 50 mL of a phosphoric acid buffer(pH 7.3). Adjust the pH to 7.3 using sodium hydroxide solution(1→2). Then, take exactly 25 mL of 0.05 mol/L iodine solution, seal it up, let it stand in a dark place for 15 minutes, add 5 mL of acetic acid, and titrate the iodine with a 0.1mol/L sodium thiosulfate solution(indicator: 1~3 mL of starch test solution). Shake it continuously until the yellow color disappears, and add 0.1 mol/L sodium thiosulfate solution at a constant rate. The end point is when the color blue disappears. Perform the blank test in the same way. The amount of phosphorous acid(H_3PO_3) shall not be more than 4.0 % calculated by the following formula.

$$1\text{mL of } 0.05\text{mol/L iodine solution} = 4.10\text{mg } H_3PO_3$$

Test solution

Phosphoric acid buffer(pH 7.3): Dissolve 138 g of Sodium phosphate, monobasic($NaH_2PO_4 \cdot H_2O$) in 800mL of water, and add sodium hydroxide solution(1→2) to make it exact 1,000 mL with water.

(5) Lead: When precisely weighing 5.0 g of HEDP and tested in accordance with the atomic absorption method or the induction combined plasma luminous intensity method, the amount shall not be more than 5.0 ppm.

(6) Iron: When precisely weighing 5.0 g of HEDP, and tested in accordance with the atomic absorption

method or the induction combined plasma luminous intensity method, the amount shall not be more than 10 ppm.

(7) Arsenic: When tested in accordance with the Arsenic Test Method, the amount shall not be more than 4.0 ppm.

Assay Weigh approximate 0.3 g of HEDP and dissolve in 50 mL of water, and titrate 1 mol/L sodium hydroxide solution with stirring. The end point is second inflection point and identify using a potentiometer. The consumption of 1 mol/L sodium hydroxide solution at the end point shall be a(mL), and the content of 1-hydroxyethylidene-1, 1-diphosphonic acid shall be obtained by the following formula.

$$\text{Content(\%)} = \frac{a \times 206.0}{\text{Sample(g)} \times 30} \times \text{Amount of phosphorous acid(\%)} \times 1.675$$

[Annex 4] Regulations on Determination of Naturally Occurring Food Additives

Chapter 1. Purpose

The purpose of this regulation is to stipulate details for determining whether the detected food additives are naturally occurring food additives, which are not intentionally used in food, health functional food and livestock products whose standards and specifications are specified according to the Article 7 of 「Food Sanitation Act」, Article 14 of 「Health Functional Foods Act」, and Article 4 of 「The Special Act on Imported Food Safety Management」.

Chapter 2. Definitions

In this Regulation, "Natural occurrence" means the condition in which the food additives are naturally derived from food but is not intentionally used.

Chapter 3. Object(Apply to)

Natural occurrence are apply to the only food additives that are detected from the food, health functional food or livestock products which is not intentionally used. However, except the food additives derived from the food materials that are already allowed to be used in those materials.

Chapter 4. Determination of Natural Occurrence

The Ministry of Food and Drug Safety's minister is able to admit the food additives as naturally occurring if a person submits scientific data to prove it as natural occurrence.

Chapter 5. Submission data

1. The scope of the submission data is as follows. However, some of the submissions may be omitted if there is a reasonable excuses.
 - A. Data on the name and content of food additives
 - B. Data on food type, mixing ratio of raw material, manufacturing process, etc.
 - C. Data that can prove the natural occurrence in raw materials and manufacturing process
 - D. Test report on food additives detected in raw materials, etc.
 - E. Other data that is recognized as to demonstrate natural occurrence
2. The issuer of a test report shall be the testing and inspection institution designated by Article 6 and 8 of 「Act on Testing and Inspection in the Food and Drug Industry」.
3. The samples shall be based on the ingredients listed in [Annex 1] "Materials Available for Food"

of 「Food Code」.

4. The number of samples shall be a total of nine of three different production sites or manufacturers. However, it may be changed if it is admitted by the Ministry of Food and Drug Safety's minister due to the supply and demand of samples and regional characteristics, etc.

Chapter 6. Request for reviews

1. The Ministry of Food and Drug Safety's minister may request reviews to the Director General of National Institute of Food and Drug Safety Evaluation, and may approve it's possibility of natural occurrence by reviewing the results overall.
2. The Ministry of Food and Drug Safety's minister may request advice from the experts if necessary, and may approve the possibility of natural occurrence based on its results. In this case, allowance and travel expenses may be paid within the budget.

Chapter 7. Data supplementation, etc

Supplementation or cessation might be required if the case fits to any of the followings :

1. Supplementation
 - A. If the data is incomplete or missing
 - B. If data is not reliable
 - C. If it is necessary for the review of the natural occurrence
2. Cessation
 - A. If it is not a subject of reviews or not comply with this regulations
 - B. If the supplementary data is insufficient for the reviews or the supplementary data has not been submitted

Chapter 8. Public disclosure

In order to prevent confusion in the administration and provide information to trader, the MFDS responds of natural occurrence might be disclosed on the web site(www.foodsafetykorea.go.kr).

No.	Regulation Number (Date of entry into force)	Contents
135	MFDS Regulation #2018-84 (2018.11.1.)	<p style="text-align: center;">Supplementary Provisions<#2018-53, 2018. 6. 29.></p> <p>Article 1(Date of entry into force) ① This regulation is effective from November 1st, 2018.</p> <p>② Notwithstanding Section ①, Use level revision of II.5.A.L-Ascorbyl Palmitate and II.5.C.(2) for Milk formulas, etc. are effective from July 1st, 2019.</p> <p>Article 2 (Example) This regulation shall apply to food additives, food or health functional foods (hereinafter referred to as "food additives, etc.") manufactured, processed, subdivided or imported(based on the date of shipment) for the first time since the date of entry into force.</p> <p>Article 3 (Interim measures for matters under inspection) If the inspection is on-going at the time of entry into force, it shall apply the previous regulation.</p> <p>Article 4 (Interim measures for food additives, etc. which are already manufactured) If the food additives, etc. are already manufactured, processed, subdivided, or imported(based on the date of shipment) following the previous regulation, they are still able to be sold after the date of entry into force(If there is a expiration date, they are able to be sold until the expiration date). Also, food additives, etc., which are manufactured or processed using these food additives, etc., are able to be sold until the expiration date of the products.</p>

No.	Regulation Number (Date of entry into force)	Contents
136	MFDS Regulation #2019-1 (2019.1.9.)	<p style="text-align: center;">Supplementary Provisions<#2019-1, 2019. 1. 9.></p> <p>Article 1(Date of entry into force) ① This regulation is effective from January 9th, 2019.</p> <p>② Notwithstanding Section ①, Use level revision of II.5.A.L-Ascorbyl Palmitate and Propylene Glycol are effective from July 1st, 2019.</p> <p>Article 2 (Example) This regulation shall apply to food additives, food or health functional foods (hereinafter referred to as "food additives, etc.") manufactured, processed, subdivided or imported(based on the date of shipment) for the first time since the date of entry into force.</p> <p>Article 3 (Interim measures for matters under inspection) If the inspection is on-going at the time of entry into force, it shall apply the previous regulation.</p> <p>Article 4 (Interim measures for food additives, etc. which are already manufactured) If the food additives, etc. are already manufactured, processed, subdivided, or imported(based on the date of shipment) following the previous regulation, they are still able to be sold after the date of entry into force(If there is a expiration date, they are able to be sold until the expiration date). Also, food additives, etc., which are manufactured or processed using these food additives, etc., are able to be sold until the expiration date of the products.</p>